



University of Kentucky  
UKnowledge

---

Agricultural Engineering Extension Updates

Biosystems and Agricultural Engineering

---

1991

# Electronic Controls for Swine Buildings

Douglas G. Overhults

University of Kentucky, [doug.overhults@uky.edu](mailto:doug.overhults@uky.edu)

R. S. Gates

University of Kentucky

**Right click to open a feedback form in a new tab to let us know how this document benefits you.**

Follow this and additional works at: [https://uknowledge.uky.edu/aeu\\_reports](https://uknowledge.uky.edu/aeu_reports)



Part of the [Bioresource and Agricultural Engineering Commons](#)

---

## Repository Citation

Overhults, Douglas G. and Gates, R. S., "Electronic Controls for Swine Buildings" (1991). *Agricultural Engineering Extension Updates*. 25.

[https://uknowledge.uky.edu/aeu\\_reports/25](https://uknowledge.uky.edu/aeu_reports/25)

This Report is brought to you for free and open access by the Biosystems and Agricultural Engineering at UKnowledge. It has been accepted for inclusion in Agricultural Engineering Extension Updates by an authorized administrator of UKnowledge. For more information, please contact [UKnowledge@lsv.uky.edu](mailto:UKnowledge@lsv.uky.edu).



# Agricultural Engineering Update



Structures &  
Environment



Soil & Water

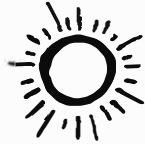

Energy



Safety



Crop Processing



Power &  
Machinery

AEU - 57

## Electronic Controls for Swine Buildings

D.G. Overhults  
R.S. Gates

### INTRODUCTION

This fact sheet discusses the use of electronic controllers to maintain the environment within swine barns. There are some special considerations when using electronic controllers to replace traditional control systems. Three main items are addressed in this fact sheet: 1) the selection of a controller, 2) installation considerations, and 3) protection against controller failure.

### SELECTION OF A CONTROLLER

Selecting a controller requires some careful investigation. Initial cost is very important, but even more important is to determine what you will control, and how you want it controlled. Fans and heaters are the most likely candidates for the equipment to be controlled, since they are the heart of any environmental control system.

For swine housing, the most common ventilation strategy is a negative pressure system, i.e. the fans all exhaust air from the building. Fresh air is drawn in through inlets by the exhaust fans. Air distribution within the building is mostly controlled by properly adjusting the air inlets as ventilation rate changes to maintain a constant pressure drop between inside and outside. The ventilation in a typical swine barn will be "staged", which means that as the inside temperature rises above the desired value, additional fans are activated at predetermined temperature "set points".

The authors are: Associate Extension Professor and Associate Professor, respectively. Department of Agricultural Engineering, Cooperative Extension Service, College of Agriculture, University of Kentucky, Lexington, KY 40546-0276.

If the temperature falls below a desired value, heaters will be activated. Staging is a practical method to keep the inside temperature near the desired value.

Traditional ventilation systems use thermostats to activate heaters and fans. In principle, these thermostats can all be adjusted so that they come on in stages. But in reality, this doesn't happen because it is very difficult to keep all the thermostats in calibration; especially when the desired inside temperature is changed frequently. Consequently, staged ventilation is a completely different way of maintaining the interior environment, and can lead to some confusion when trying to select a controller. Once the fundamental idea of staged ventilation is understood, deciding what equipment to put on each stage is fairly straightforward and may even be specified by the integrator in some locations.

For minimum ventilation, there are two basic approaches. Some controllers have built-in interval timers to run fans. Many, however, do not and so conventional mechanical timers must be used. The location of these timers should be close to the controller, for ease in making timely adjustments. The other prevalent form of minimum ventilation is to use a variable speed fan. Many electronic controllers have the capability of running variable speed fans. If the controller does not contain this capability, then a stand alone speed controller must be used. Again it is preferable to install this near the controller for ease of adjustment. Remember, the amount of fuel used is directly related to the rate of minimum ventilation. So any steps that can be taken to ensure that minimum ventilation is correctly set can result in fuel savings.

Setting heat stages is generally straightforward. Some controllers have more than one stage for heat, so that if the inside temperature continues to drop after the first stage of heat is activated, another stage will be activated. Also, some controllers have multiple inside temperature sensors that can be used independently to activate heaters in the area that the sensor is located. This is typically called "zone heating". Controllers with this feature tend to be quite a bit more sophisticated, and more expensive.

#### EXAMPLE SWINE BARN INSTALLATION

To illustrate an example of how to use an electronic controller, consider the swine barn in Figure 1.

As shown in Figure 1, the swine barn has one sidewall fan for minimum ventilation, two sidewall fans for summer ventilation, and one or two LP gas heaters. Each fan is on a separate 240 VAC circuit. One pair of heaters is placed on a 120 VAC circuits.

A possible staging schedule is as follows:

TABLE 1: STAGE SCHEDULE.

Stage	Equipment Operated
Heat	H1 and H2
1	S1
2	S2
3	S3

This staging of the ventilation equipment provides for a gradual increase in the number of fans as the inside temperature rises. Another alternative is to approximately double the ventilation for each stage.

To visualize how the system will operate, it is helpful to consider what stage is activated as the inside temperature varies around the set point temperature. Figure 2 illustrates how the example building would operate. If the inside temperature is more than 3°F colder than desired, then the heat stage is activated. As the barn temperature warms up, the heat stage shuts off and stage 1 is activated. For this example, stage 1 is connected to sidewall fans S1 and S3, which are operated by the controller's interval timer.

As the interior temperature continues to rise, additional stages are activated. The temperature difference between stages is 3°F in this example. Once the inside temperature exceeds the set point by 18°F, all fans will be running.

### INSTALLATION CONSIDERATIONS

Once a general strategy for the heating and ventilation system is decided upon, the task of selecting a controller can be done. There are some hidden costs in implementing controllers that are not readily apparent. First, most controllers are not built to directly switch large electrical loads such as fan motors. Instead, they have a "control relay" for each stage, which in turn activates the coil of a "power relay" that actually switches the equipment on or off (see Figure 3). These power relays typically cost from \$25 to \$75 each, and at least one per stage is required. More than one power relay per stage can be useful, for instance to control multiple heaters on one heat stage. Several companies manufacture relay boxes, which consist of several power relays pre-wired with ON/OFF/AUTO switches (Figure 4). The "ON" position provides a manual override of the controller, the "OFF" position typically is used as a disconnect, and the "AUTO" position is used under normal operation. These units typically cost about \$50 per relay.

Another important consideration is how the controller interacts with air inlet control. In many older swine barns, there is no air inlet control except for one or more hand cranks used to adjust the inlet width. Newer operations typically use automatic inlet controllers or self-adjusting inlets that attempt to maintain a constant static pressure difference between inside and outside. This type of system is very easy to utilize with virtually any environmental control system, because the inlet controller will automatically adjust inlets as the number of fans operating changes. Some new environmental controllers have a feature to adjust inlets (or curtains) based on temperature. This is very beneficial for buildings that utilize curtains as part of a ventilation strategy. Another method is to connect a curtain controller to one stage of the electronic controller. Equipment dealers that are familiar with a specific line of control equipment can be very helpful in putting together systems of this type.

One advantage of electronic controls is that they can be installed in an office or storage room where they are not exposed to the animal environment. The controller and all auxiliary equipment should be installed in a central location, preferably near the electrical service panel. A very useful technique is to attach all the equipment to a board and pre-wire as much of it as possible before installation. A 4" or 6" deep raceway mounted at the bottom of the board is essential to a clean installation. Flexible conduit can be used to attach each piece of equipment to the raceway. Electrical circuits can be intercepted from the service panel and routed into the raceway. Then power relay lines can be run from the raceway back to the original lines feeding the equipment. On a new installation, the raceway and control board can be the first "stop" for power lines.

For existing buildings, another approach is to install the power relays near the fans to be activated. This can save on wiring costs, because low voltage coils (such as 24 V) can be used so that 20 or 22 AWG wire can be run from the control relays to the appropriate power relays. If a power relay is used remote from the controller, it is a good idea to select one with the on/off/auto switch configuration described above. This can be used to provide a safety disconnect near the equipment.

#### **PROTECTION AGAINST CONTROLLER FAILURE**

An independent and reliable alarm system is widely recognized as an essential piece of environmental control equipment. The alarm system senses temperature extremes, and perhaps additional items such as power failure and low water pressure. The system activates one or more alarm-sounding devices, usually a loud audible alarm. Many newer installations are also activating an automatic telephone dialer that can repeatedly call several pre-programmed numbers with a warning message. Some operators also use a telephone pager in conjunction with these systems, so that they are immediately notified when the alarm is activated, even if they are far from the swine barn or their telephone. Another excellent feature for curtain-sided barn is an automatic curtain drop system that activates if inside temperature exceeds an upper limit.

As important as an alarm system is, it is very important to note that it should be the last line of defense against a controller failure. While a controller failure is fairly uncommon, it is a real possibility. Any electronic system that has life-support responsibilities should have mechanical backup thermostats and timers that can maintain a reasonable environment. The best way to provide these backup devices is by connecting them "in parallel" with the environmental controller. For swine buildings we have designed three distinct mechanical backup systems. Each mechanical backup system provides a separate function. These functions are: 1) low temperature safety, 2) high temperature safety, and 3) winter minimum ventilation. Each backup system is described in the following sections. To facilitate the illustration of these systems, the schematic of the swine barn in Figure 1 is used.

#### **Low Temperature Safety Override**

For low temperature protection in the event of a controller failure, the heater circuit is provided with a mechanical thermostat connected in parallel with the electronic controller (Figure 5). Regardless of the operation of the controller, if the mechanical thermostat senses a temperature that is lower than its setting, then it will close and provide power to the heaters. If more than one pair of heaters is desired, then two thermostats should be used. To wire this arrangement, the hot leg of the 120 VAC power circuit must be intercepted between the power relay and the service panel.

#### **High Temperature Safety Override**

For the possibility of controller failure during hot weather, it is essential to activate fans. In principal, this is identical to the low temperature safety override, except the mechanical thermostat is wired to activate "on rise" (Figure 6). This backup should be installed on the largest fan (or pair of fans if 2 fans are on a single circuit). This should provide enough air for survival until a high temperature alarm is activated. If additional ventilation backup is desired, another thermostat could be used. To wire this arrangement, either leg of the 240 VAC power circuit to the fans should be intercepted between the power relay and the service panel. Note that if an automatic curtain drop unit is installed in the building then this back-up is not necessary.

## Minimum Ventilation Override

If the controller fails at a time of minimum ventilation, there is a possibility that animals could suffocate. To cover this event, the schematic in Figure 7 illustrates a backup for a variable speed fan.

To override a controller failure, a thermostat is installed parallel to the variable speed control. If the maximum fan output is more than 4 times the minimum ventilation rate, a conventional mechanical timer should also be installed in series with the thermostat. A relay is also installed on the output side of the variable speed control to prevent any power backfeed to the speed controller.

The system works as follows. If the controller fails and ventilation stops, the thermostat contacts will close when the inside temperature rises above the thermostat set point. Full power will then be provided to the fan. If a timer is installed, the fan will operate at full speed according to the timer setting. Note that this system can also be used with a stand alone speed controller.

To use the system, the operator must adjust the thermostat and mechanical timer MT, to a setting that is appropriate for the animal weight, and outside temperature.

## TRANSIENT OVER-VOLTAGE PROTECTION

In addition to an independent alarm system and the mechanical backups discussed above, an often-overlooked item is transient over-voltage protection. This is sometimes referred to as "lightning protection", which is really not the same because transient over-voltages can come from a variety of sources. And while they may not have the full energy of a direct lightning strike, they can wreak many different kinds of havoc with electronic equipment. Most controller manufacturers are providing a reasonable level of protection built directly into the controller. However, no controller is fully protected. Reliability can be substantially improved by simply adding transient protection to the electrical system. The following additional levels of protection are recommended:

1. A lightning arrester on the main service.
2. Properly grounded building service.
3. Transient arrester for the building service.
4. Transient suppressor for the circuit with the controller.

The most common transient arrester used is the Metal Oxide Varistor, referred to as an MOV, or sometimes just a varistor or lightning arrester. It can sense an over-voltage on a line and very quickly shunt that over-voltage to ground. Each leg of the electrical service, including neutral, should be protected. Because the over-voltage is shunted to ground, it is very important that a proper ground is provided. If in doubt, the utility company can make a simple measurement to determine the adequacy of the service ground. Another prevalent surge arrester is a gas discharge device. While not quite as fast acting as an MOV these can be adequate.

Transient arrestors are available in the price range of about \$25 up to several hundred dollars. Beware of imitations, such as "silicon oxide arrestors", unless they are rated by an independent laboratory (such as Underwriter's Labs) to survive the ANSI Standard C62.41-1980 transient over-voltage test waveform. Look for "Category A or B" level protection for circuit and electrical service protection, respectively. Some manufacturers are listed in the Reference Section.

Lightning protection is also very important. Most swine barns do not have

any lightning protection. As an absolute minimum the feed bins and any metal building exterior should be grounded. An excellent source of lightning protection information is the National Fire Protection Association (Batterymarch Park, Quincy MA).

The most commonly damaged equipment in swine barns due to nearby lightning strikes is telephone equipment. Many of the more sophisticated environmental controllers can remotely dial a central computer to send information and receive changes to the building set points. And, as pointed out above, many new alarm systems utilize an automatic dialer for remote warning. These systems are very vulnerable to transient over-voltage, and should be protected by placing a surge suppressor on the telephone service, and on each piece of equipment that is connected to the telephone system. The telephone company can provide the service protection, and provide more information on surge suppressors for equipment connected to phone lines. Again, look for surge arresters that are independently tested to pass the ANSI Standard C62.41-1980.

#### REFERENCES

The following two references are available from the University of Kentucky Cooperative Extension Service for \$5.00 each.

1. MWPS-28. 1987. Farm Buildings Wiring Handbook. Midwest Plan Service. Iowa State University, Ames IA 50011
2. FEC. 1987. Agricultural Wiring Handbook. Eighth Edition. National Food and Energy Council Publication 8701, 409 Vandiver West-Suite 202, Columbia, MO 65202

The following companies manufacture surge suppression devices, some of which are suitable for use in swine facilities. (The University of Kentucky does not endorse any of these products; they are listed as a convenience only.)

1. Joslyn Electronic Systems Corporation, Santa Barbara Research Park, P. O. Box 817, Goleta, CA 93116. (805) 968-3551. Customer Service: (800) 752-8068. (Model Z2-175)
2. MCG Electronics, Inc., 12 Burt Drive, Deer Park, NY 11729. (516) 586-5125. Applications Assistance: (800) 851-1508.
3. General Electric Corporation, Ft. Edward, NY 12828. Customer Service: (518) 745-5750, for a local distributor. (Ask for Models 9L 15EC V-001 or 9L 15 EC C-001).

1/18/91  
300 copies

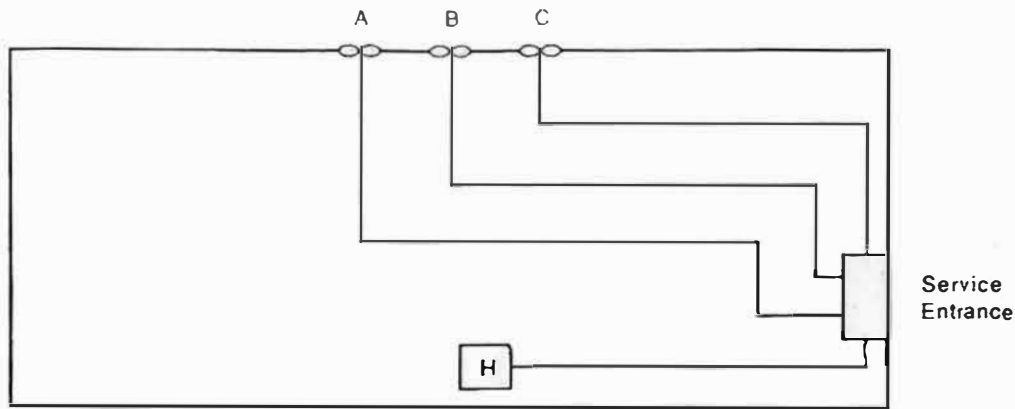

<u>Circuit</u>	<u>Description</u>
A	1 - 18" VARIABLE SPEED FAN (240 VAC)
B	1 - 24" SINGLE SPEED FAN (240 VAC)
C	1 - 24" SINGLE SPEED FAN (240 VAC)
H	1 or 2 GAS FIRED HEATERS (120 VAC)

FIGURE 1: An example of electrical circuits for ventilation and heating in a swine grower building. This system uses 1 variable speed fan (A) for minimum winter ventilation. Two additional fans, each on a separate circuit, provide additional ventilation in warm weather. One or two gas fired space heaters can be installed on another circuit.

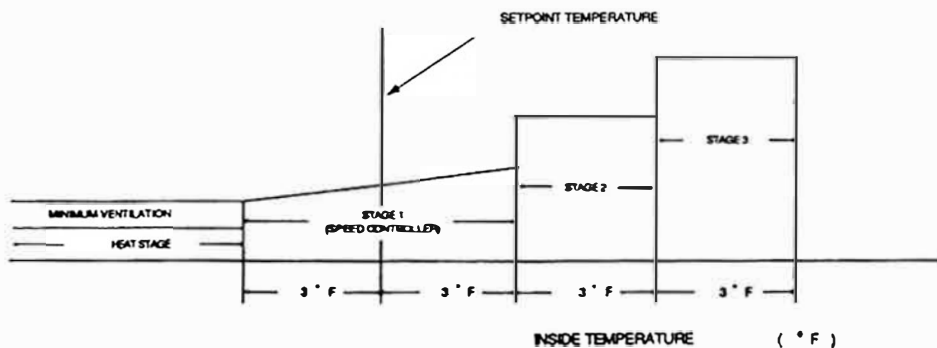

FIGURE 2: Staging diagram for the example building in Figure 1. As inside temperature varies about the setpoint temperature, different equipment is activated according to what "stage" the system is in. For this example there is a constant 3°F between each ventilation stage. The temperature must drop 3°F below the set point before the heaters are activated. See Table 1 for the equipment that is assigned to each stage.



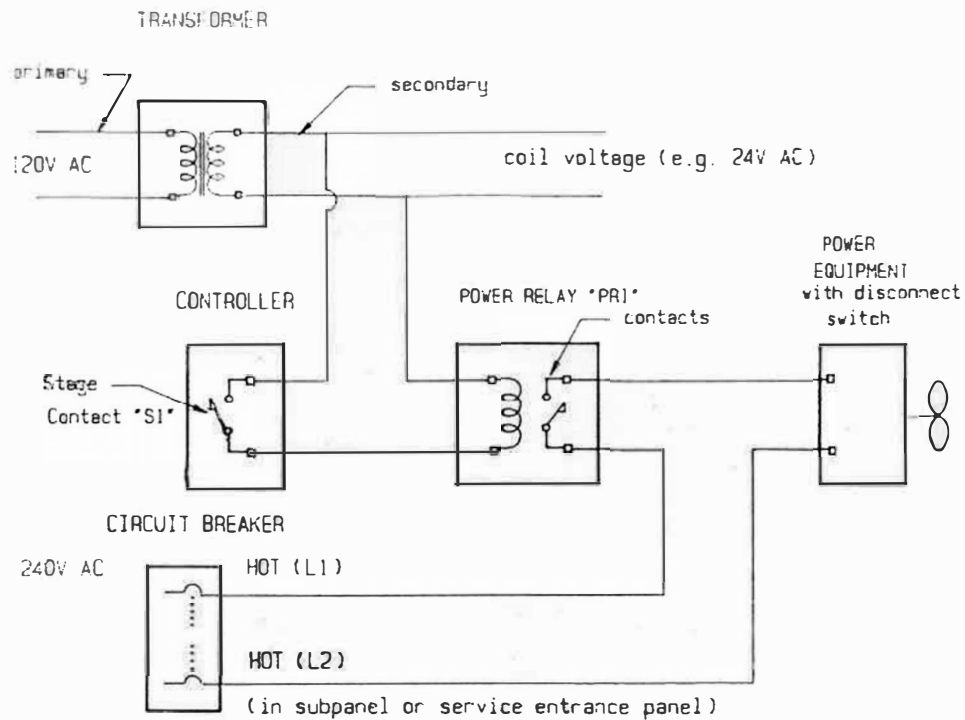

FIGURE 3: Example of the Use of A Controller to Actuate A Fan. When controller contact S1 closes, current flows through the power relay (PR1) coil. This closes the PR1 contacts and provides power to the fan motor. NOTE that in this schematic, only one leg of the power to the motor is shown switched by PR1; however, use of a double-pole relay would allow both legs to be switched. Note that failure of either the power relay, or the controller, would result in no ventilation in this simple example.

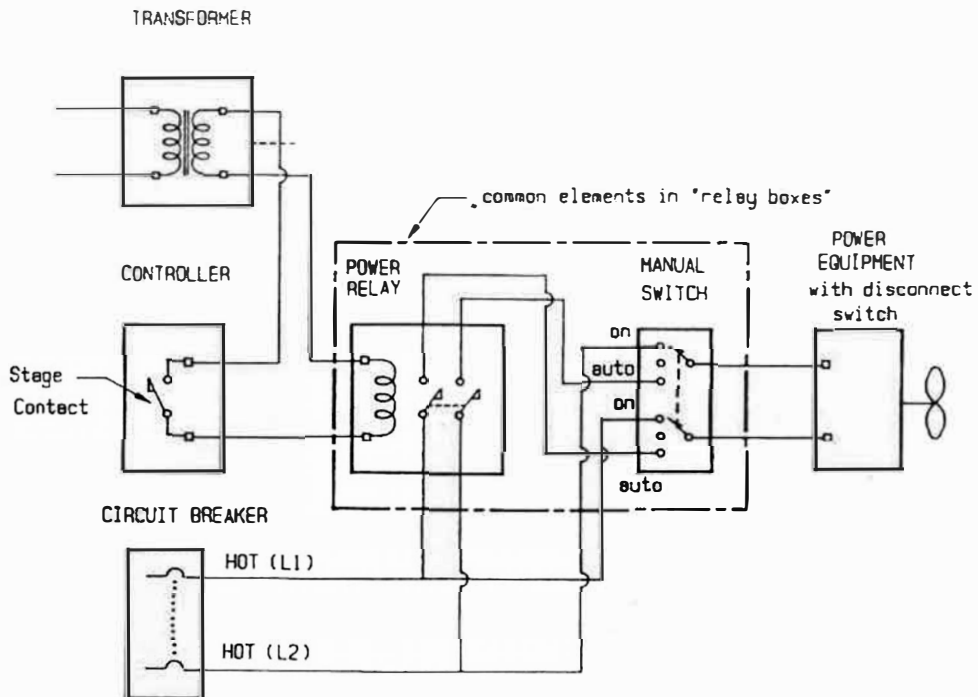

FIGURE 4: A "relay box" provides automatic control functions when the manual switch is placed in the auto position, and allows operation as described in Figure 3. When the manual switch is placed in the "OFF" position, both legs of the power circuit are broken; whereas in the "ON" position the automatic control is overridden and the fan runs continuously. These units can be purchased individually, or several per enclosure. Most also provide a lamp to indicate whether power is on the equipment side of the manual switch.

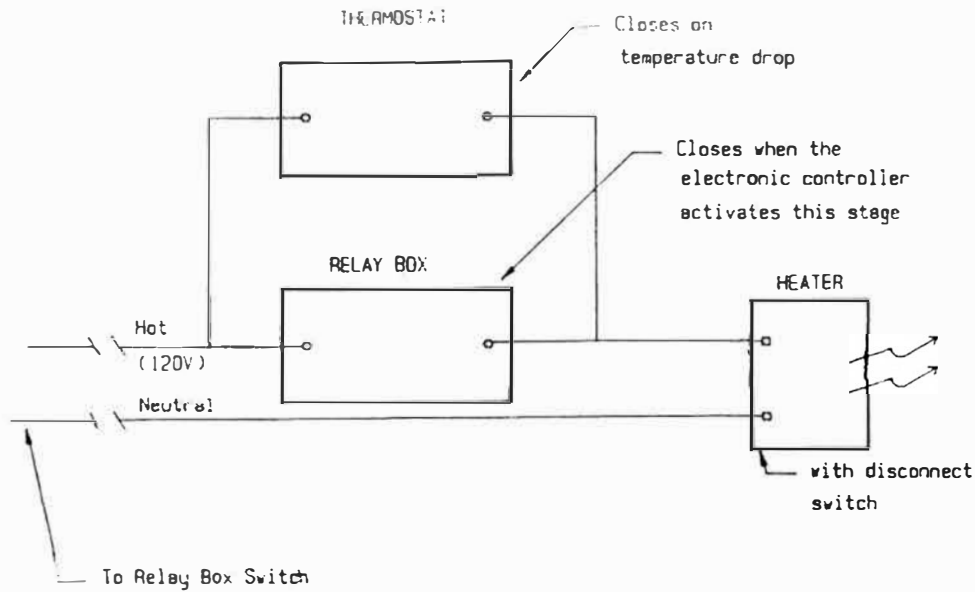

FIGURE 5: Low Temperature Safety Override. LPG heater on a single 120 V circuit is turned ON by either the relay box, or the override thermostat. The thermostat is set to turn ON if the temperature drops below 60°F, even if the controller fails or if the relay box fails. For small animals or low animal density a higher temperature should be selected, e.g. 70°F.

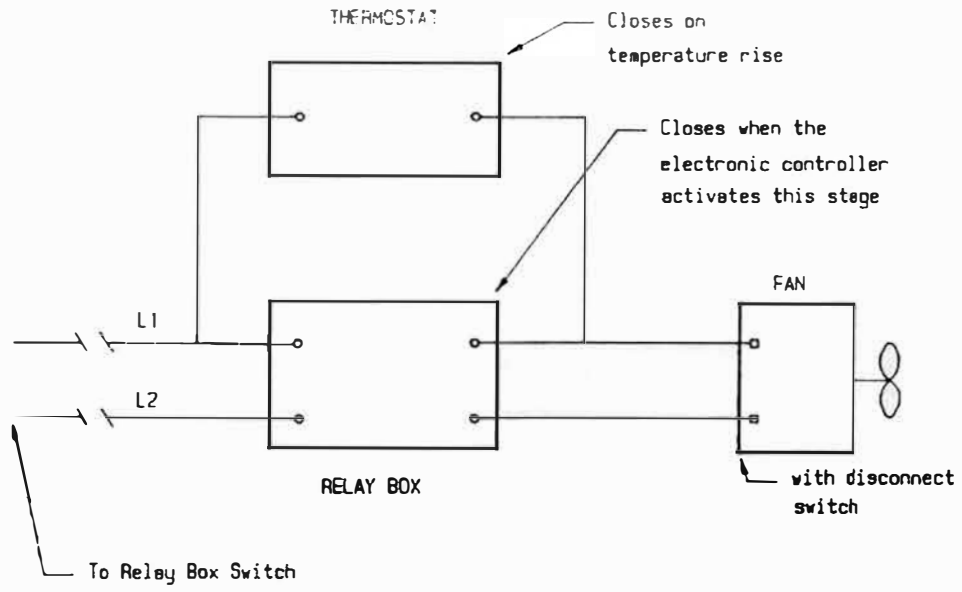

FIGURE 6: High Temperature Safety Override. The largest fan(s) on a single 240 V circuit are turned ON by either the relay box contacts, or the over-ride thermostat. The thermostat is set for a temperature at which the fans must always be on. For this example using fan S3 which is stage 3, a setting of 85°F is recommended. If the controller fails, or if the power relay fails, this fan will run anytime the temperature exceeds 85°F.

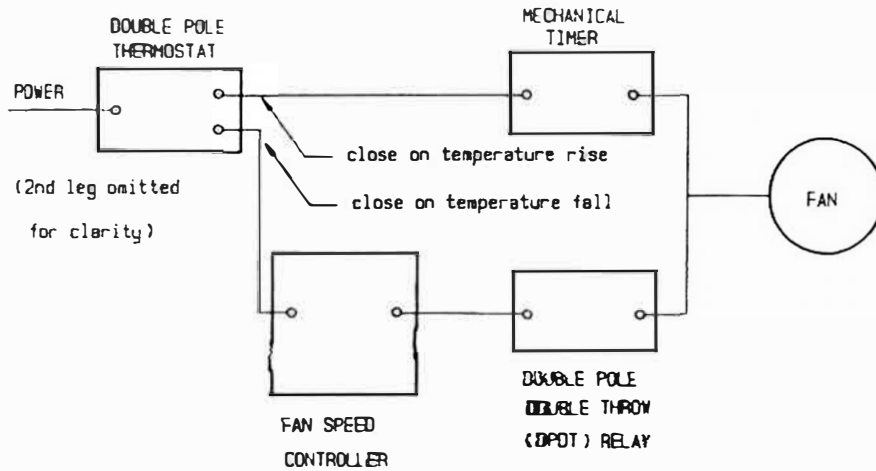

FIGURE 7: Minimum Ventilation Override. For this example, minimum ventilation is provided by a fan speed controller connected to a variable speed fan. To provide mechanical back-up of the speed controller, a thermostat is used to override main power and instead direct it to a mechanical timer connected to the fan. If the temperature exceeds the thermostat setting, the fan will be run by the back-up system; if the temperature is less than the thermostat setting the speed controller runs the fan. Note that the use of a DPDT relay to disconnect power from the speed controller output may be necessary with some models. Also, a mechanical timer may not be necessary depending on the capacity of the fan.