



University of Kentucky
UKnowledge

Agricultural Engineering Extension Updates

Biosystems and Agricultural Engineering

1997

Moveable Curing Frames

George A. Duncan

University of Kentucky, gduncan@uky.edu

Larry D. Swetnam

University of Kentucky, larry.swetnam@uky.edu

Linus R. Walton

University of Kentucky, lwalton@ca.uky.edu

Right click to open a feedback form in a new tab to let us know how this document benefits you.

Follow this and additional works at: https://uknowledge.uky.edu/aeu_reports

 Part of the [Bioresource and Agricultural Engineering Commons](#)

Repository Citation

Duncan, George A.; Swetnam, Larry D.; and Walton, Linus R., "Moveable Curing Frames" (1997). *Agricultural Engineering Extension Updates*. 7.

https://uknowledge.uky.edu/aeu_reports/7

This Report is brought to you for free and open access by the Biosystems and Agricultural Engineering at UKnowledge. It has been accepted for inclusion in Agricultural Engineering Extension Updates by an authorized administrator of UKnowledge. For more information, please contact UKnowledge@lsv.uky.edu.

Moveable Curing Frames

Low cost, low labor, moveable, sturdy, dependable and easily covered -- is this an ideal curing structure? Can it be done? Seeking such a design is the aim of ongoing studies using the cantilever-beam concept for supporting two rails of stick tobacco on a central beam.

Being able to locate the curing frames close to the field reduces transport time at the busy harvest time. Possibly filling directly from

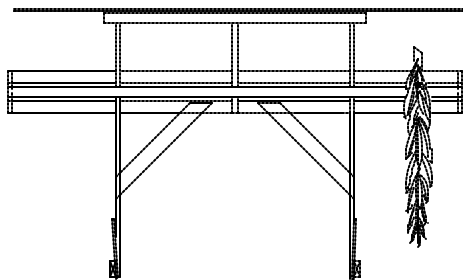

the stick row cuts out a lot of the conventional loading-unloading time and expense. Working at ground level eliminates the dangers of climbing and working on tier rails in the tall barns. Reducing labor and costs is essential to continuing profitable tobacco production.

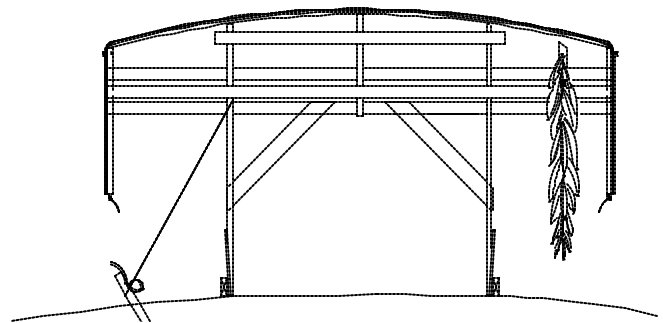

Fall 1996 Trials:

Two moveable curing frame designs were tested at the UK Woodford Co. Research Farm the fall of 1996. The basic frame design consisted of three 14-ft 2x4's nailed to the edge of two 8-ft 2x6 legs to form the cantilever stick support beam. A six-foot 2x6 base was nailed to the bottom end of the 2x6 legs to provide a free-standing frame. Two 2x4's were nailed across the top ends of the 2x6 legs to provide a lifting rail and plastic support members. These lifting members enabled a tractor front-loader to move empty and filled frames. A similar frame design was first tested in 1983-84 in barn-curing studies. The bottom tines of a round bale mover on a front-mounted tractor loader were successfully used to move the frames in this study.

One group of 20 frames were transported to the field with the tractor loader and filled directly from the stick rows of tobacco. After all were filled, the frames were moved to a nearby sod area and

aligned end-to-end.

A small rope was stretched across the top of each row of frames to help support the plastic covering. Four-mil black plastic was used to cover the frames about one week after filling. The plastic was secured to the frames as best possible with plastic baler twine looped over and under the frames and tied.

Another group of 20 empty frames were aligned side-by-side at the sod area and filled from flat bed wagon loads of tobacco hauled from the nearby field. These frames had a 15-ft 1x4 bowed and nailed over the top of the legs and down to the ends of the stick support members to form an additional support for the plastic covering. The plastic was held down to the 1x4 bow with small nailing strips and 6d nails or double-strand twine pulled snugly over the bow and secured at the ends. The nailing strips had 6d nails about every 18 inches from the edge of the frame up to as far as a worker could reach from a step ladder (about 5 ft).

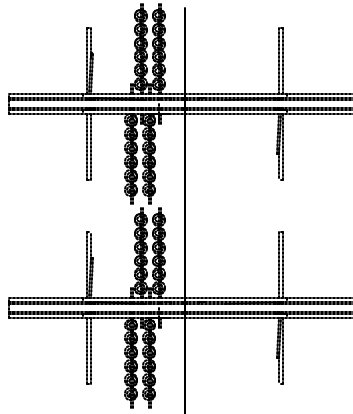
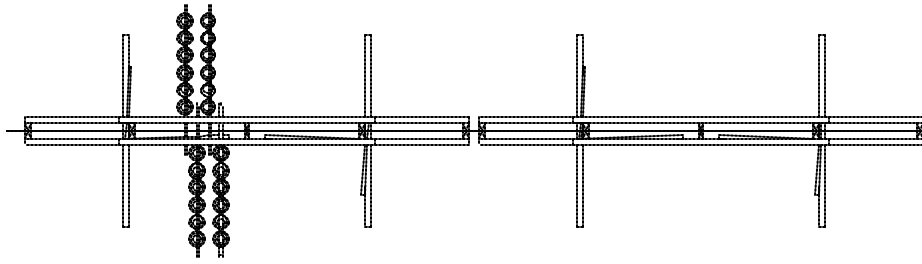

Results:

The uplift of the wind on the plastic literally pulled the wooden strip and nails from the 1x4 pine bow! The double-strand twine seemed to work better in this test and is recommended over the nailing strips.

The labor for transporting the frames and filling in the field for the one group of frames was approximately 11 worker-hours per acre.

The labor for hauling the tobacco and filling the other group of frames at the sod area was approximately 17 worker-hours per acre.

The labor for covering was approximately

5 additional worker-hours per acre capacity of frames (22-23 frames per acre).

Reaching up to shoulder-height to place the tobacco in the cantilever beam is more tiring than conventional loading but may be better than standing on tier rails. Handling each heavy stick only once or twice is certainly a savings of time and energy over the multiple times to load and pass sticks up to the top tiers in a barn.

Covering with plastic was a task similar to covering the post-row structure. Just be sure to choose a day with calm winds and have three to four good helpers!

The strong winds of last October caused

serious damage to the plastic during the curing period and literally blew over each group of frames at different times. The blow-over occurred after the tobacco had nearly cured and lost so much weight that the frames were too light and top-heavy to withstand the broad-side winds on

We feel that stronger six-mil black plastic would be worth the extra cost to be more resistant to tearing. The top edges at the ends of the bow-type frames need some form of protection to help reduce stress points and tearing of the plastic. Use small pieces of plastic to form a padded cover over the 1x4 and 2x6 top corner.

Our preliminary conclusions are that moveable (or portable) curing frames can definitely provide a means of reducing the curing structure and labor costs, can cure tobacco equivalent to normal barn curing and offer a means of being located close to the field, *but must be anchored or protected against the strong winds of fall weather*. A means of easily and quickly 'staking down' or otherwise securing the

the ridge-top location. (The wind intensity was gusts of 35-40 mph or higher as reported by the weather service.) Other wind damage also occurred around the state at that time.

frames will be determined in the spring of 1997. This information will be disseminated to those interested in these moveable frames before the 1997 curing season. Keep alert to distribution of this information.

The moveable curing frames offer the tobacco grower another option for successfully reducing labor and costs for producing air-cured tobacco but with some additional weather risks which can be minimized with diligent application and management of the plastic and anchoring the frames against high winds.

By George Duncan, Larry Swetnam, and Linus Walton, Dept. of Biosystems and Agric. Engr., U. Ky. Coll. of Agric. 1-97

WARNING: THIS FRAME DESIGN WILL TURNOVER IN HIGH WINDS.
 Means of securing these frames in high winds is to be determined prior to the 1997 curing season & reported to all interested. Be alert for the information.

Basic Des.,
 Sh. 1 of 2

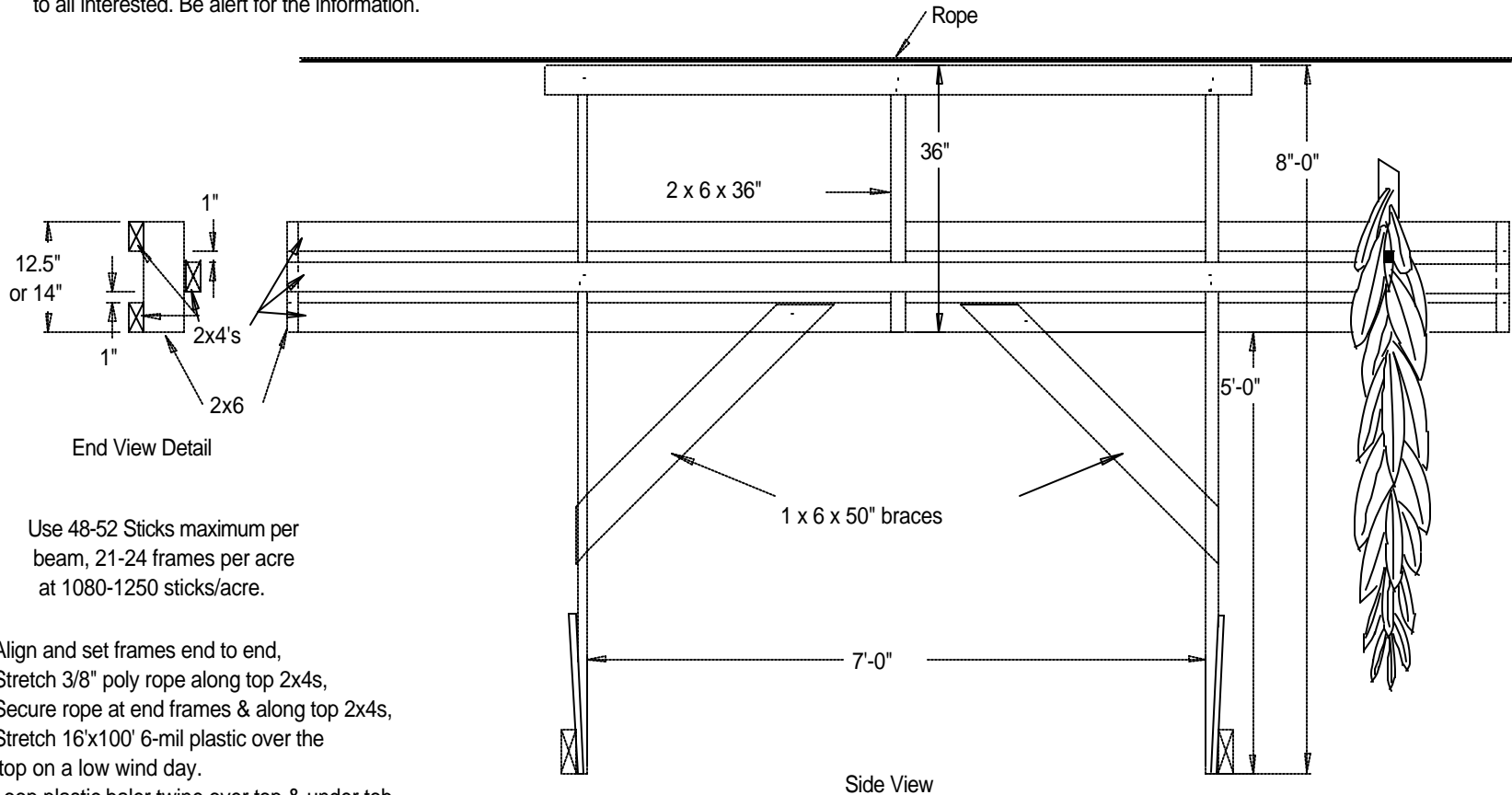

Use 48-52 Sticks maximum per beam, 21-24 frames per acre at 1080-1250 sticks/acre.

Align and set frames end to end,
 Stretch 3/8" poly rope along top 2x4s,
 Secure rope at end frames & along top 2x4s,
 Stretch 16'x100' 6-mil plastic over the top on a low wind day.
 Loop plastic baler twine over top & under tob.,
 2 loops per frame length, twine under leg brace sometimes to secure better.
 Tie plastic ends securely. Overlap ends of plastic 8'-10' over frames & double-tie to continue covering of long rows.

MOVEABLE CURING FRAME
 Cantilever Stick Type - Basic Design
 BAE/UKy, Sh. 1 of 2, 1/97

Every 3rd to 5th stick should penetrate the plastic on each side of the row of curing frames.
Plastic twine should be attached to an end frame and continuously looped round each stick protruding from the plastic covering on both sides of the frame row.
Roll up lower edges of plastic to stick level for ventilation.

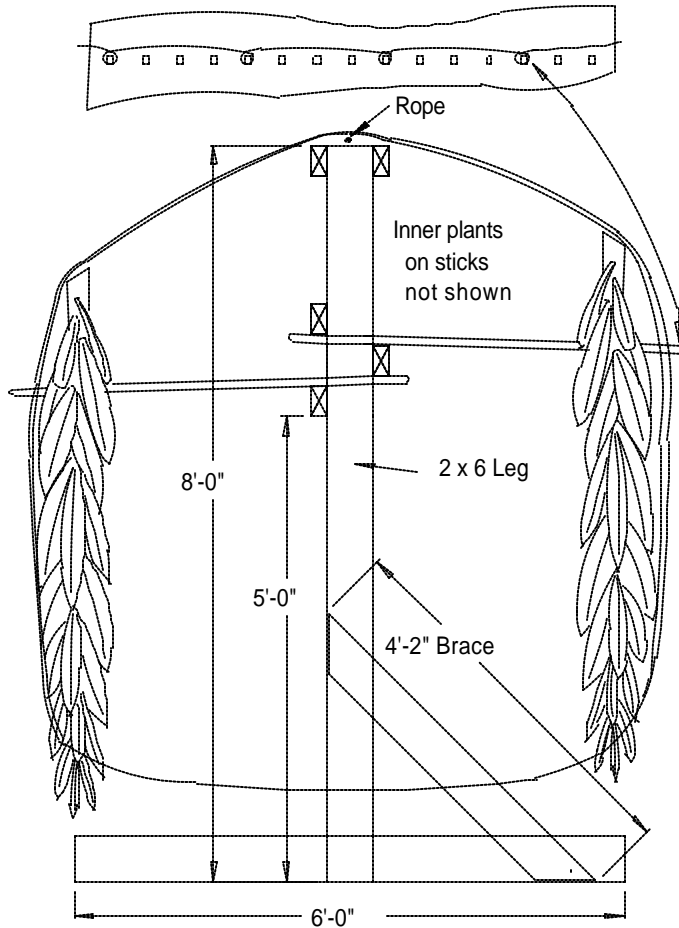

Materials (S4S or Full Dimension Lumber):

- 2 x 4 x 14 ft. 3 ea Rails
- 1 x 6 x 8 ft 2 ea Braces (or 1 16')
- 2 x 6 x 12 ft 1 ea Bottom Spts. = 81 Bd Ft
- 2 x 6 x 6 ft 1 ea Ends, Middle Blks
- 2 x 6 x 8 ft 2 ea Legs
- 2 x 4 x 8 ft 2 ea Top Pick-up rails

Screw-shank Pole Barn Nails:

- 3.5" (16d) for S4S lumber - 1/2 lb
- 2.0" (6d) for S4S bows & strips - 1/4 lb
- or
- 4.0" (20d) for Full Dim. lumber - 1/2 lb
- 2.5" (8d) for Full Dim. bows - 1/4 lb

3/8" Rope, Plastic Baler Twine - Length as Req'd

All lumber should be pressure treated for longer life

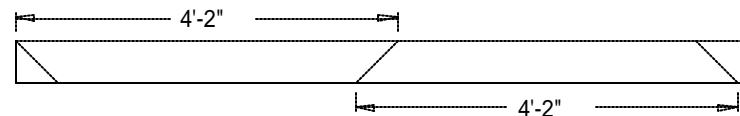

Cutting Pattern for 1x6 Braces from 8'-0"
(or 16'-0") Board, All angles 45°

MOVEABLE CURING FRAME
Basic Design - Cantilever Stick Type

BAE/UKy, Sh. 2 of 2, 1/97

Use small pieces of plastic over corners to cover wood edges & keep from tearing plastic sheet.

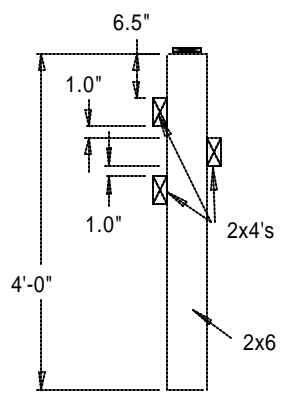

End View Detail

Anchor stake & double-twine tie on windward side

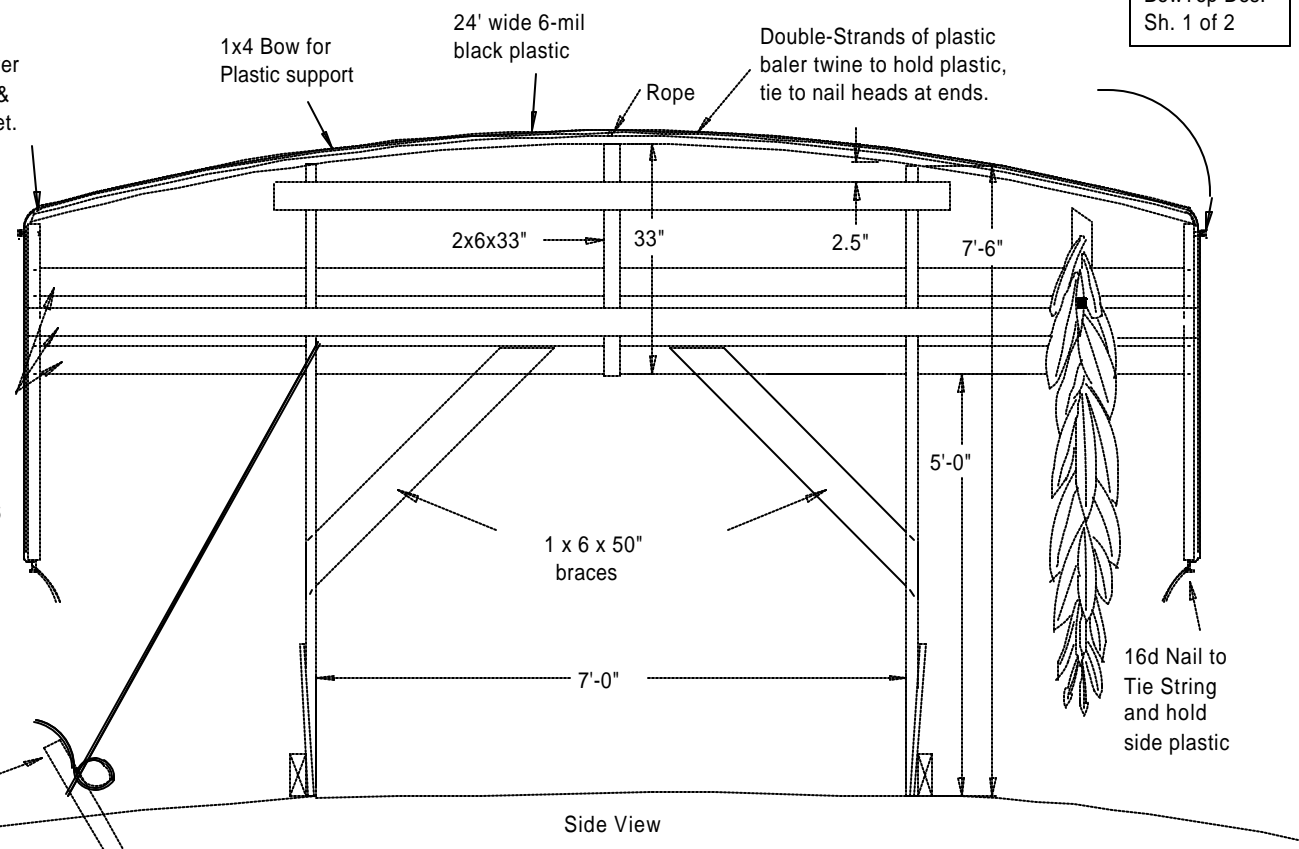
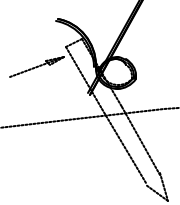

Side View

WARNING: THIS FRAME DESIGN WILL TURNOVER IN HIGH WINDS.
Means of securing these frames in high winds is to be determined prior to the 1997 curing season & reported to all interested. Be alert for the information.

Align and space frames 7.5'-8' apart,
Stretch 3/8" rope across top-center,
Tie rope at end frames,
Stretch 24'x100' plastic over top
on low-wind day, use double strands
baler twine over top tied to 16d nail
into each end 2x6. Slide side plastic
up & down under twine for vent.

Use 48-52 Sticks maximum per
frame, 21-24 frames per acre
at 1050-1250 sticks/acre.

MOVEABLE CURING FRAME w/BOW-TOP
Cantilever Stick Type - Bow-Top Design
BAE/UKy, Sh. 1 of 2, 1/97

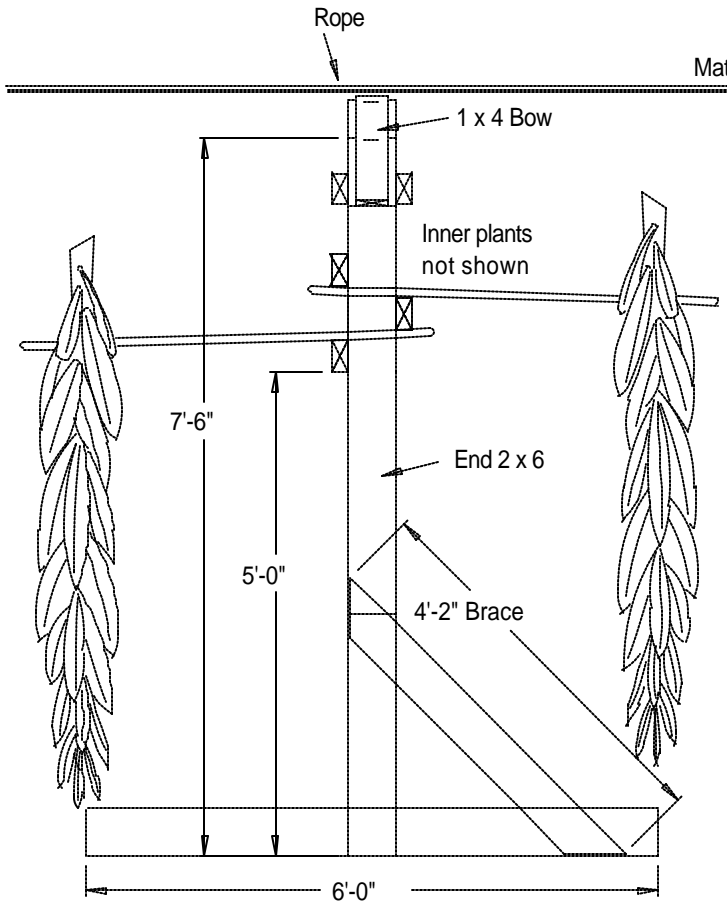

Materials for Bow-Top Frame (S4S or Full Dimension Lumber):

- 2 x 4 x 14 ft. 3 ea Rails
- 1 x 6 x 8 ft 2 ea Braces
- 2 x 6 x 12 ft 1 ea Bottom Spts. = 92.3+
- 2 x 6 x 8 ft 2 ea Legs (cut to 7'-6") Bd Ft
- 2 x 6 x 8 ft 1.5 ea Ends & Middle
- 2 x 4 x 8 ft 2 ea Top Lift 2x4s
- 1 x 4 x 15'(or 16') 1 ea Bow
- 2 x 2 x 2 ft 1 ea Stake

3/8" Poly Rope, Pl. Baler Twine - Length as Req'd

Screw-shank Pole Barn Nails:

- 3.5" (16d) for S4S lumber - 1/2 lb
- 2.0" (6d) for S4S bows & strips - 1/4 lb
- or
- 4.0" (20d) for Full Dim. lumber - 1/2 lb
- 2.5" (8d) for Full Dim. bows - 1/4 lb

All lumber should be pressure treated for longer life

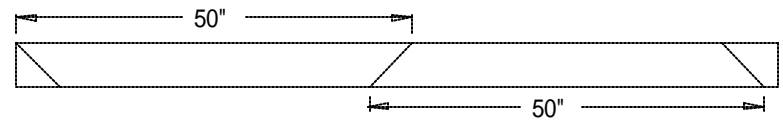

Cutting Pattern for 1x6 Braces, All angles 45°

MOVEABLE CURING FRAME
Cantilever Stick Type
Bow-top Design
BAE/UKy, Sh. 2 of 2, 1/97

