



University of Kentucky
UKnowledge

Agricultural Engineering Extension Publications

Biosystems and Agricultural Engineering

6-1992

Micro-Sprinkler and Fan Cooling for Dairy Cows: Practical Design Considerations

Larry W. Turner
University of Kentucky

Richard C. Warner
University of Kentucky, richard.warner@uky.edu

John P. Chastain
University of Kentucky

Right click to open a feedback form in a new tab to let us know how this document benefits you.

Follow this and additional works at: https://uknowledge.uky.edu/aen_reports

 Part of the [Bioresource and Agricultural Engineering Commons](#)

Repository Citation

Turner, Larry W.; Warner, Richard C.; and Chastain, John P., "Micro-Sprinkler and Fan Cooling for Dairy Cows: Practical Design Considerations" (1992). *Agricultural Engineering Extension Publications*. 19.
https://uknowledge.uky.edu/aen_reports/19

This Report is brought to you for free and open access by the Biosystems and Agricultural Engineering at UKnowledge. It has been accepted for inclusion in Agricultural Engineering Extension Publications by an authorized administrator of UKnowledge. For more information, please contact UKnowledge@lsv.uky.edu.



Micro-sprinkler and Fan Cooling for Dairy Cows: Practical Design Considerations

by Larry W. Turner, Richard C. Warner and John P. Chastain
Agricultural Engineering Department

Research and on-farm demonstrations have shown that micro-sprinklers, spray jets and fan cooling systems can be effective in relieving heat stress in dairy cows under hot, humid conditions. Based on these results, many dairymen are considering installing sprinkler and fan cooling. Several Kentucky dairymen have already installed sprinkler cooling systems, but they could improve their performance by modifying them to take into account the principles involved and the components used in sprinkler and fan cooling.

Heat Stress Effects

The need for such systems arises from the effects of heat stress on dairy cows. The thermoneutral temperature range, or “comfort” zone, for most dairy cows is about 40-75°F. Above 75°F, increases in temperature and/or humidity begin to cause heat stress.

Heat stress can reduce feed intake, milk production, and breeding efficiency in dairy cows. Losses in the pocketbook follow when milk production and breeding efficiency drop. Declines in milk production of as much as 25% have been reported for summer conditions in the humid Southeast. Over a summer season (June 1-September 30) heat-stress-related losses can range from about 55 lb/cow in Maine to about 1,000 lb/cow, or more, in Texas for a cow milking 66 lb/day.

Methods for Heat Stress Relief: Water, Shade and Ventilation

There are several means available for reducing heat stress in dairy cows. Providing plenty of clean and available water, enough shade, and good ventilation should be routine. These areas are the first places to concentrate if a heat stress problem is evident in the herd. Some type of cooling system can then be considered after the more routine practices are taken care of.

The most economical cooling method is evaporative cooling using spray jets or mini-sprinklers and fans. Results from research at the University of Kentucky and elsewhere have given us improved design and operation guidelines for such systems.

Sprinkler and Fan Cooling Principles

In sprinkler and fan cooling, the sprinklers create droplets that wet the cow’s hair coat to the skin. Fans are then used to force air over the cow’s body (see Figure 1), causing evaporative cooling to take place on the skin and hair coat. Heat from the cow’s body causes the moisture to evaporate. The droplet size must be large enough to wet the skin surface and must be applied intermittently to allow time for the moisture to evaporate from the skin. Air movement is needed in fairly humid climates, such as that in Kentucky, to provide enough drier air above the skin to do a good job of evaporating the water.

Fog or mist systems (with very fine sprays) are not recommended for dairy cattle in Kentucky because of the humidity levels during the summer. Those systems attempt to cool the air around the cow rather than cooling her skin directly. In the arid West this works well, but in more humid areas, a “steam bath” effect can actually be created. Therefore, for the eastern and midwestern United States, sprinkler and fan cooling should be used rather than fogs or mists.

Cooling Benefits

Several system designs and weather conditions have been studied for sprinkler and fan cooling systems. Systems tested in Kentucky and Florida, as well as in other locations, have demonstrated the potential benefits. Feed intake, milk production and cow comfort have all been shown to increase by using sprinkler and fan cooling. Current research has reduced the amount of water used from 50-75 gal/hd/day to as low as 6 gal/hd/day which reduces potential herd health problems, such as mastitis.

Response Measurement	Control Group	Cooled Group	Difference	
Feed Intake (% change)				
Florida (dry matter) lb/day	39.2	41.0	+2.8	(+ 7.1%)
Kentucky (as fed) lb/day	77.0	84.1	+7.1	(+ 9.2%)
Missouri (as fed) lb/day	72.3	77.4	+5.1	(+ 7.1%)
Milk Production (% change)				
Florida lb/day	39.8	44.4	+4.6	(+11.6%)
Kentucky lb/day	50.1	58.0	+7.9	(+15.8%)
Missouri lb/day	51.4	55.8	+4.4	(+ 8.6%)
Israel lb/day	72.8	78.0	+5.2	(+ 7.1%)
Rectal Temperature				
Kentucky (11 AM) °F	102.6	101.6	-1.0	
Missouri (PM) °F	102.6	101.8	-0.8	
Milk Temperature				
Missouri °F	102.4	101.5	-0.9	
Respiration				
Rate-Breath per minute				
(% change)				
Florida	96	57	-39	(-40.6%)
Kentucky	91	75	-16	(-17.6%)

Table 1 summarizes the benefits of sprinkler and fan cooling found in several research trials conducted in the U.S. and Israel. Based on these trials, you could expect increases in net income of 25-30 cents/cow/day after paying for the increased feed costs, water, and electricity costs. With that amount of increased income, you can expect a good return on investment in the system for many areas of the eastern and midwestern United States. In Kentucky, the system will pay for itself in one year or less on many farms.

Planning and Component Selection

Several commercial dairies in Kentucky, Florida and other locations have installed variations on the system, although some of the specific design questions and techniques are not yet well defined by research. If you are considering installing a sprinkler and fan system on your dairy, there are some general design guidelines you should follow in locating the system, selecting the nozzles and the fans, and ensuring a good water supply.

Locating the System(s)

For best results, the system should be located under shade. A shaded feed bunk (Figure 1) or the holding pen (Figure 2) are the two locations currently recommended in Kentucky. Because of some concern over possible mastitis

problems, location of a sprinkler system in a free stall barn may not be desirable, particularly if straw, sawdust or other absorbent bedding is used. Adequate drainage (1/8-1/4"/ft slope) is needed wherever the system is installed to avoid ponding of water.

Selecting the Nozzles

The most important aspect of selecting a nozzle type is to have a large enough droplet size to wet the cow's skin. Irrigation nozzles and solid-cone coarse-droplet spray nozzles are desirable. Successful systems have been installed using nozzle sizes ranging from 7 gph to 300 gph. A size range of 7 to 30 gph (0.12 to 0.5 gpm) per nozzle is preferred to conserve water, reduce the total required flow rate and avoid runoff problems.

Either 180° (half-circle) or 360° (full-circle) nozzles may be used. The 180° nozzles work well mounted next to a feed bunk, spraying away from the feed to help avoid wetting it. The 360° nozzles work well in a holding area. When choosing nozzles, take note of the pressure specifications and spray pattern radius.

The spray radius is used to determine the nozzle spacing. The pressure requirement indicates the operating pressure suggested for a particular installation. For example, nozzles that have a 4 ft spray radius should be spaced no more than 4 ft apart to achieve a relatively even distribution.

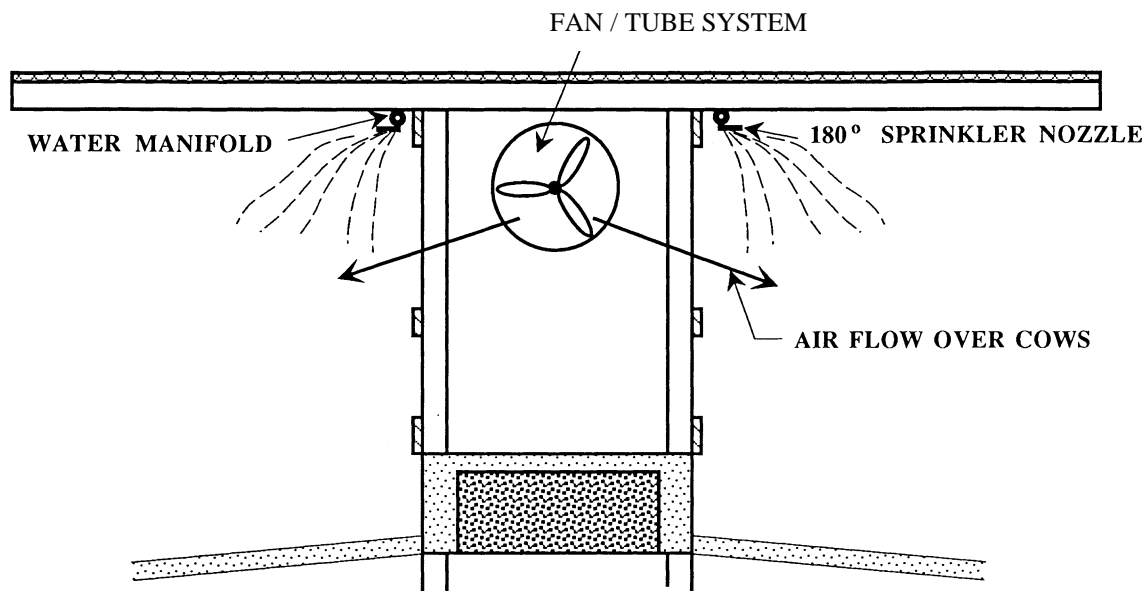

Figure 1

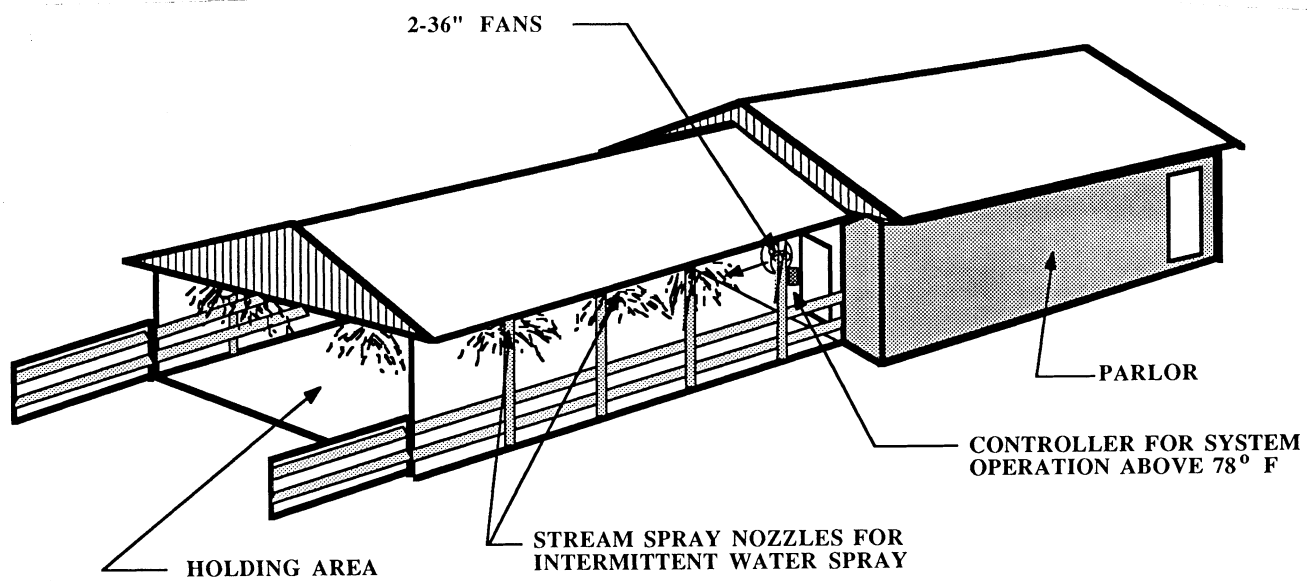

Figure 2

When selecting a spray jet or micro-sprinkler, consider these factors:

- nozzle size,
- whether the nozzle spins or is stationary,
- the type of spray pattern, i.e., stream or fan,
- flow rate,
 - radius, and
 - recommended operating pressure.

Both the flow rate and spray radius will increase as the nozzle opening and operating pressure increase.

The recommended nozzle pressure for most spray jets and micro-sprinklers is 20 to 25 psi. If the operating pressure is too high, the droplet size will be reduced and the resulting mist will drift. Also, the smaller droplet will not penetrate through the animal's hair coat to the skin, and much less cooling will occur. Thus, as shown in Figure 3, a pressure regulator should be installed in the system to limit the required nozzle pressure to these recommended values.

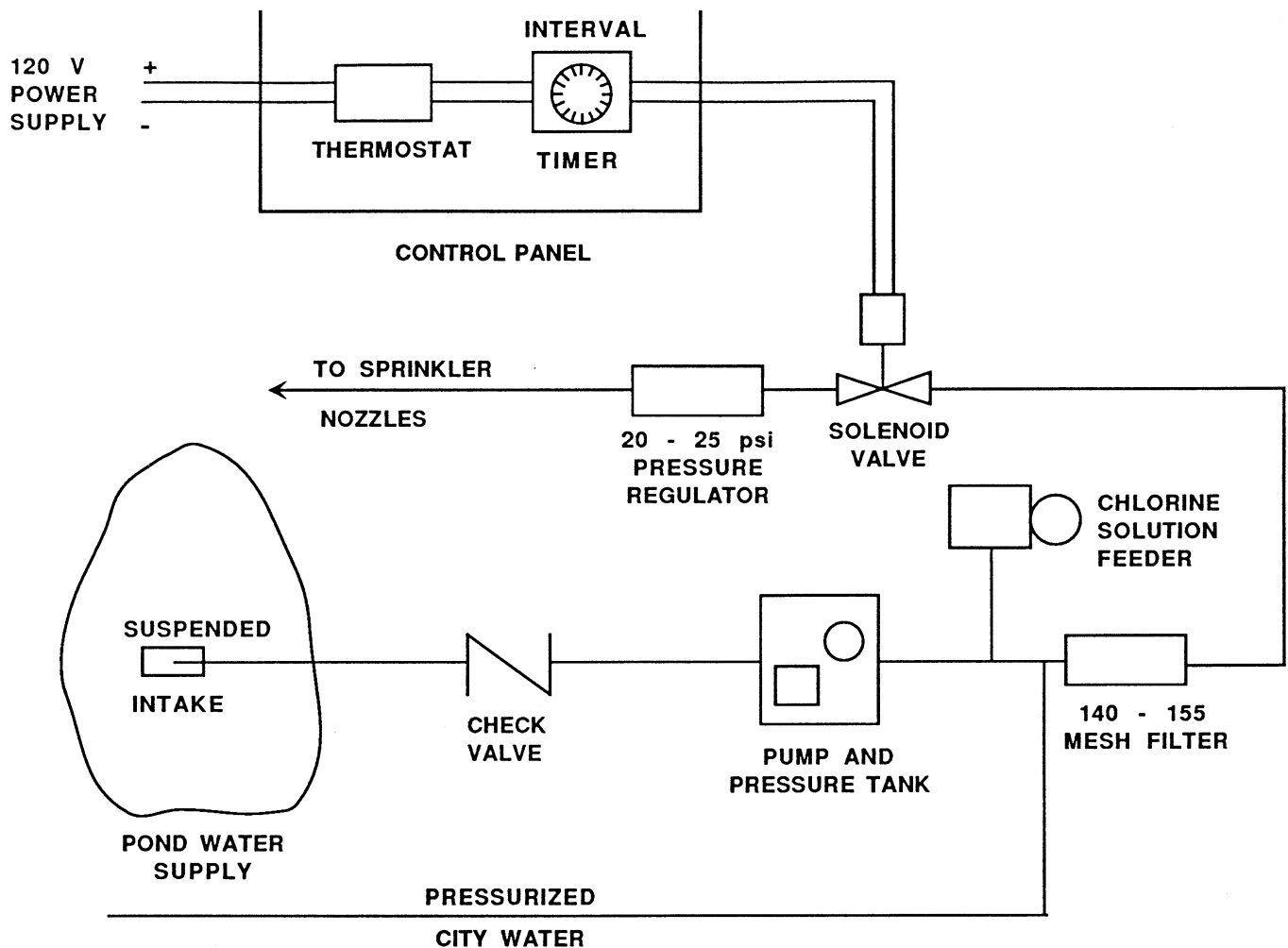

Figure 3

Water Supply and Pipe Requirements

The water supply can be a municipal system, pond, well or other farm source. If a farm source is used, a filter and/or water treatment unit may be needed (see Figure 3). A 140 to 155 mesh filter is recommended for most applications. The water system must be able to deliver the flow rate needed to supply all of the nozzles operating at a given time.

If the low volume-low pressure spray jets are used, water delivery is not a problem. For example, a system for a 96 ft feed bunk which has 18 nozzles spaced approximately 5 ft apart, each delivering 7.5 gph, would require about 2 gpm. If nozzles were on both sides of the bunk, running at the same time, 4 gpm would be required.

That requirement would be in addition to any other water needs at the same time on the dairy for watering, cleaning, etc. For example, if nozzles delivering 1 gpm with a 12 ft spacing were used, then a total flow rate of 16 gpm would be needed, which may exceed the flow expected through a

standard household water meter. Table 2 lists flow rates for standard water meters commonly used on farmsteads.

Both PVC (rigid white plastic pipe) and PE (black plastic pipe) are used in several installations. The smaller diameter (1/2" to 3/4") black plastic pipe, which is less costly, should contain 2% or higher carbon black and an anti-oxidant to prevent degradation from sunlight and oxidation. Also, PE pipe simplifies the installation and requires less fittings.

The pipe size requirement will vary for each system based on the selected spray jet or micro-sprinkler and the operating pressure. Safe flow rates for PVC and PE pipes used for water conveyance are listed in Table 3.

For the feed bunk pipe, where water is being discharged throughout the pipe length by evenly spaced spray jets or micro-sprinklers, a 1/2" PE pipe conveying 4 gpm will have an overall pressure loss over the 100 ft length of approximately 4 psi. This will produce only an 8% change in nozzle discharge for most micro-sprinklers.

Size of Water Meter	Size of Service Line	Gallons per Minute at Static Pressure (psi)			
		30	45	60	75
5/8"	3/4"	4	8	11	14
3/4"	3/4"	6	10	14	17
3/4"	1"	8	14	18	21
1"	1"	10	17	24	28

Size	PVC	PE
1/2	5	4
3/4	10	10
1	16	16

A filter is recommended for many applications; an in-line plastic or stainless steel 140 to 155 mesh filter will perform well (see Figure 3). Sand or centrifugal filters may be required if a large amount of sediment is present in the water supply.

Selecting Fans

Air movement in the velocity range of 200 ft to 400 ft per minute across the cows is needed. However, the air movement at the cow level depends on the discharge characteristics of the fan and the distance of the cow from the fan.

Fan/tube systems have been successfully used in Kentucky to provide the required air movement. They should be sized to provide 150 to 250 cubic feet per minute (cfm) of air flow per cow. For tubes mounted high above the cows, a flow rate of as much as 400 cfm/cow may be needed. If the tube is installed outdoors or in reach of the cows, then a rigid or semi-rigid duct should be used to prevent damage. Hole size and spacing in the tube or duct can be determined by the manufacturer or dealer once the air flow requirement is set.

Large diameter rigid tubes can become costly and may not be readily available. More information is available on poly-tube systems in the University of Kentucky Cooperative Extension publication AEN-7 *Poly-tube Heating-Ventilation Systems and Equipment*.

Another type of fan often used, particularly in holding pens or other areas with higher eave heights, is a 1/2-hp 36" fan. Such fans will blow about 10,000 to 11,000 cfm with a "throw" distance of about 30 ft. A 1-hp 48" fan will provide 21,000 cfm with an effective throw distance of about 40 ft. These fans should be mounted out of reach of the cows and angled downward slightly.

Overhead paddle fans can also be used to provide airflow, but they offer limited air movement unless cows are directly under a fan. The paddle fans do have much higher efficiencies of operation, with ratings of 100 cfm/watt of power input, as compared to 15 to 20 cfm/watt for conventional propeller-type fans.

Controls are a Key

The controls are a key part of the system for assuring the most effective cooling. A thermostat is required to control the sprinkler and fan. The system should begin cooling when the temperature reaches 78°F. The fans should run continuously whenever the system is on. An adjustable timer with a 30-minute cycle should be used to control the sprinkler interval. In the feed bunk area, an "ON" time of 1 to 3 minutes in each 10 to 15 minutes is recommended. For the holding area, use a slightly longer "ON" time and a shorter "OFF" time than in the feed bunk system.

A solenoid valve (electrically activated valve) is necessary to turn the water ON and OFF. The valve diameter should be the same as the sprinkler water line.

The goal for controlling the cooling system should be to adjust the timer so that the sprinklers wet the cows to the skin, the spray shuts OFF, and then the water evaporates until the hair coat is only slightly damp. The timer then should start the process over as long as the thermostat senses a temperature above the set point.

Assembling Components

Most of the components of a sprinkler and fan system are available from irrigation suppliers or electrical and hardware stores. Package systems (except for fans) can also be bought commercially. The fans can be purchased from farm supply stores or catalogs. If a neighbor is using a sprinkler system, ask him about improvements or changes he would make. Most importantly, include the basic principles needed for a workable and successful system: intermittent sprinkling, large droplet size and air movement with fans.

Costs and Benefits of the System

Based on field demonstration work and the results of research, costs and benefits can be estimated for micro-sprinkler and fan cooling. Table 4 indicates cost estimates for installation and operation of the system for a 48-cow herd in Kentucky over an 800-hour run-time season. Using these cost estimates, the total system would cost \$33.50/cow to install.

Table 4: Estimated Forced Evaporative Cooling System Costs for a 48-Cow Milking Herd.	
Item	Cost
30" Diameter, 1 HP fan	\$ 615
30" Rigid Duct, 50' long	200
Thermostat	36
Duct Hangers and Wiring	80
Timer	50
Solenoid Valve + Coil	48
1/2" Plastic Pipe, 100'	15
18 Plastic Nozzles, 180°	21
Mounts, Fittings, Filter, Etc.	45
Labor for Installation (estimated)	500
Total Investment Cost	\$1,610
Operating Costs*	
Water Cost	
430 Gal/Cow/Season or \$51 @ 25¢/100 Gal. => 1¢/Cow/Day	
Electricity Cost	
16.7 kWh/Cow/Season or \$52 @ 6.5¢ kWh => 1¢/Cow/Day	
*Assuming 800 hours of run time over the season.	

For large-scale systems, some economy of scale would be possible to reduce the cost per cow. Table 5 gives a summary of payback potential for the system. These cost estimates indicate the system has potential to pay back in slightly more than one season of operation in Kentucky, based on milk production benefits alone, for a 100-day heat stress season.

Potential Herd Health Concerns

Research trials of fan and sprinkler cooling system have not shown increases in mastitis for cooled cows. However, more research is needed to examine this aspect of the cooling system. If the area where the water is applied does not drain well, cows may lie in ponded water and could have an increased likelihood of mastitis.

In on-farm tests, no incidences of mastitis in excess of "normal" occurrences have been documented for either feed bunk or holding pen installations. However, concern still exists, and it is currently recommended that the system not be used in a free stall barn other than in the area of a covered, in-barn feed alley.

Table 5: Simple Payback for Forced Evaporative Cooling System*.		
Milk Value (Cents/Cow/Day)	Costs (Cents/Cow/Day)	
50	Feed	19
	Spray Water	1
	Fan Energy	1
	Drinking Water	2
	Total Cost	23
Net Income = 27¢/cow/day		
Simple Pay Back = 124 Days		
*Assuming increased feed intake of 5 to 6 lb/cow/day and increased milk yield of 4 lb/cow/day.		

Qualitative Assessments

Conversations with dairymen involved in the detailed demonstrations, as well as in dairy operations in other installations in Kentucky, indicate they are pleased with the performance of the system. The cows are attracted to the bunk more readily when the system is in place and operating during hot weather. Limited performance data are available for evaluation of the benefits of the system on commercial Kentucky dairies, but general impressions of performance benefits are positive.

With respect to nozzle types and sizes, spray intervals, and system performance for optimal cooling and conservation of water, many questions remain. Current research at the University of Kentucky and other institutions should enable refinements and improved specifications to be developed. However, dairymen do not need to wait for these refinements to install a system. The positive benefits have already been demonstrated, and any additional research information should be easily adapted to an existing system.

If you have questions or need additional information about micro-sprinkler and fan cooling, contact your county Extension office. A videotape illustrating the system is available through the office, and additional details may be obtained by your County Agricultural Agent through the Agricultural Engineering Department at the University of Kentucky.

Educational programs of the Kentucky Cooperative Extension Service serve all people regardless of race, color, age, sex, religion, disability, or national origin. Issued in furtherance of Cooperative Extension work, Acts of May 8 and June 30, 1914, in cooperation with the U.S. Department of Agriculture, C. Oran Little, Director of Cooperative Extension Service, University of Kentucky College of Agriculture, Lexington, and Kentucky State University, Frankfort. Copyright © 1997 by the University of Kentucky Cooperative Extension Service. This publication may be reproduced in portions or its entirety for educational or non-profit purposes only. Permitted users shall give credit to the author(s) and include this copyright notice.