



3-2005

Selecting an Air-Cure Tobacco Housing and Curing Facility

George A. Duncan

University of Kentucky, gduncan@uky.edu

Larry D. Swetnam

University of Kentucky, larry.swetnam@uky.edu

Right click to open a feedback form in a new tab to let us know how this document benefits you.

Follow this and additional works at: https://uknowledge.uky.edu/aen_reports



Part of the [Bioresource and Agricultural Engineering Commons](#)

Repository Citation

Duncan, George A. and Swetnam, Larry D., "Selecting an Air-Cure Tobacco Housing and Curing Facility" (2005). *Agricultural Engineering Extension Publications*. 16.

https://uknowledge.uky.edu/aen_reports/16

This Report is brought to you for free and open access by the Biosystems and Agricultural Engineering at UKnowledge. It has been accepted for inclusion in Agricultural Engineering Extension Publications by an authorized administrator of UKnowledge. For more information, please contact UKnowledge@lsv.uky.edu.



Selecting an Air-Cure Tobacco Housing and Curing Facility

by George A. Duncan and Larry D. Swetnam, Extension Agricultural Engineers

Once or twice in a lifetime the average tobacco producer faces the decision of what tobacco housing and curing facility he needs to build. For some, this may be to replace a barn that has burned or blown down. For others, the need may arise from an expansion of production by farm acquisition or lease-in of extra poundage.

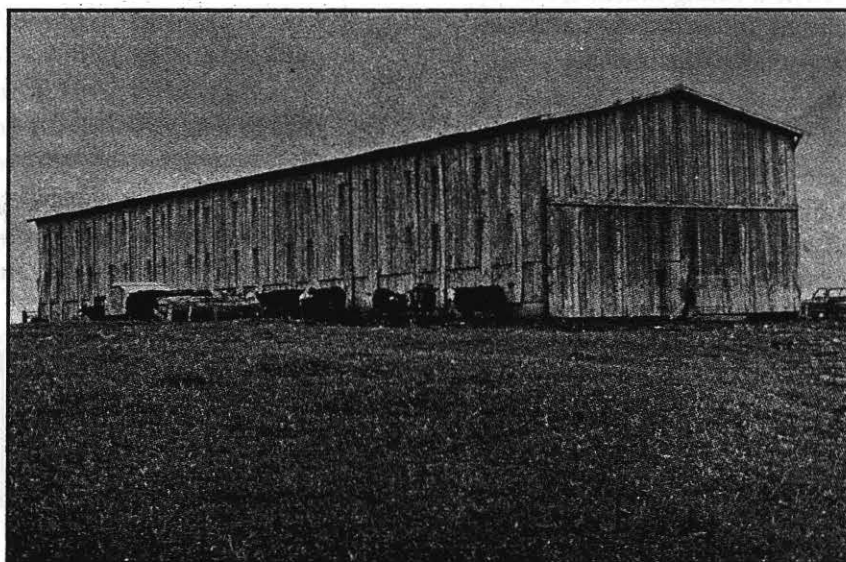

- other possible farm uses for the barn during the non-curing season, such as machinery and supply storage or animal shelter.
- future modifications for different tobacco housing and curing methods because these methods could change significantly in the future.

Thus, a burley producer needing a new barn now seems to have three

In all cases, it is important to build the most suitable facility for present and projected production methods. With labor becoming more costly and scarce, labor-saving features are a must. Rising material and construction costs continue to increase the initial investment costs past previous levels.

An air-cure tobacco barn (burley or dark) is the largest single investment required in the present conventional tobacco production system. Trends toward mechanization affect whether a facility will be obsolete or needed at all in a few years.

As a producer considers his new facility, he certainly would not rebuild the historic tall five- and six-tier barns that were built during an era of plentiful low-cost labor and home-grown lumber. Likewise, a builder would not want to suggest to the producer that he can build only patterns of that type.

A producer should consider:

- the two-, three-, and possibly four-tier barn designs in which tobacco can be housed with smaller crews and less total labor,
- the cable-hoist system type barns, or
- the portable frame system type barns that use tractor forklift handling and housing.

general concepts for tobacco housing:

1. Select a low-cost, short-term curing method to get by for a few years and then reconsider tobacco housing needs; or
2. Build only the basic frame and roof for a tobacco barn or a partially enclosed facility as economically as possible now and then complete, modify, or convert it to other options in the near future; or
3. Build a good permanent facility with the best labor-saving and versatility features that are available.

The remainder of this publication is intended to help you decide which of these three concepts you will choose and the various types of barns available to fit your needs. Certainly you will want to get construction estimates, financing, insurance, tax information, and other related data before you arrive at a final decision.

Air-Cure Tobacco Barn Alternatives

Extensive research and on-farm studies over the past several years have produced several types of tobacco barn designs and alternative methods of housing and curing. All feature improvements aimed at labor savings, modern economical construction methods, and flexibility for future tobacco

housing changes and other farm uses. Even though separate publications describe the various methods in more detail, the main features are summarized here to give an overall understanding and perspective of each method, emphasizing which might best fit a particular producer's needs.

The different types of curing facilities and housing methods presently available are:

1. *Three- and four-tier air-cure barn, conventional housing, or one-worker cable-hoist system.*
2. *Two-tier forced-air barn, two-worker housing.*
3. *Open-interior air-cure barn with portable curing frames, one-worker, tractor-forklift housing.*
4. *Two-tier partially enclosed air-cure barn, two-worker housing*
5. *One-tier plastic-covered field-curing structure, one- or two-worker manual housing, or one-worker cantilever-beam hydraulic-trailer, or cable-hoist housing.*
6. *Machine shed with removable tier rails for small acreages, two-worker housing.*

These tobacco barns feature pole-type construction and the traditional post-pier type construction. Pole-type construction is rather simple, straightforward, and economical. Also, the pole-frame provides a stronger structure with a more open interior because it requires fewer braces than traditional post-pier construction. Preservative-treated round poles or square posts have been rather plentiful and readily available.

The traditional post-pier type construction requires more internal wind bracing and is not as easily modified for other tobacco or future farm uses. However, these types are often built a little cheaper by local barn builders who are familiar with and experienced in these traditional methods of construction. Using untreated lumber throughout will help reduce the total material cost unless the concrete and labor cost for piers equals the pressure-treated wood cost.

Many small producers or part-time farmers want a so-called "combination" or "general purpose" barn for housing some tobacco as well as machinery, hay, cattle, etc., as the needs arise. Since such individual requirements are quite varied and no one or two plans might fit all interests, we suggest obtaining a basic two- or three-tier air-cure barn plan and using one shed or driveway portion for tobacco and another for the other uses. Hay can be stacked from the ground up, inexpensive farm gates can be used for temporary cattle stalls, etc., as long as one use does not interfere with the other.

Some examples of undesirable conditions are cattle having access to fallen tobacco leaves, manure or odor contaminating tobacco, or hay blocking tobacco ventilation, etc. Any horse stalls should be permanently built for safety and durability, which generally causes interference and inconvenience with the hanging of tobacco over the stalls. Therefore, we would suggest placing horse stalls along one side and possibly building a loft over the horse stalls for feed or equipment storage. Tobacco would be omitted from this area unless absolutely necessary. Obtain a copy of a suitable horse barn plan to get construction details for walls, doors, ventilation, the loft, etc., if you do wish some horse stalls in your special tobacco barn.

Specific features of the above tobacco facilities and methods are summarized in the following sections.

Conventional Air-Cure Tobacco Barns

The three- and four-tier air-cure designs are updates of previous conventional burley and dark air-cure barns. The main features are:

1. *Three tiers all across the barn spaced 4'-6" to 4'-10" apart vertically for reduced tobacco overlap and with standard 48" spaced tier rails horizontally or the narrower 38"-40" alternate spacing for easier standing and housing. The 40-foot wide barn has a fourth tier in the center driveways.*
2. *Three-worker housing: one on the wagon and two in the barn hanging the three or four tiers.*
3. *Twenty-foot eave height, a lower slope (3:12) roof, and approximately 10-foot overhead clearance (from the ground to the cross beams), except for the 40-foot wide three-driveway barn which has an optional 12-foot center driveway overhead clearance design.*
4. *Full-width track or hinged doors for drive-through convenience and positioning the wagon under all tier rails for easier handling and hanging of the tobacco.*

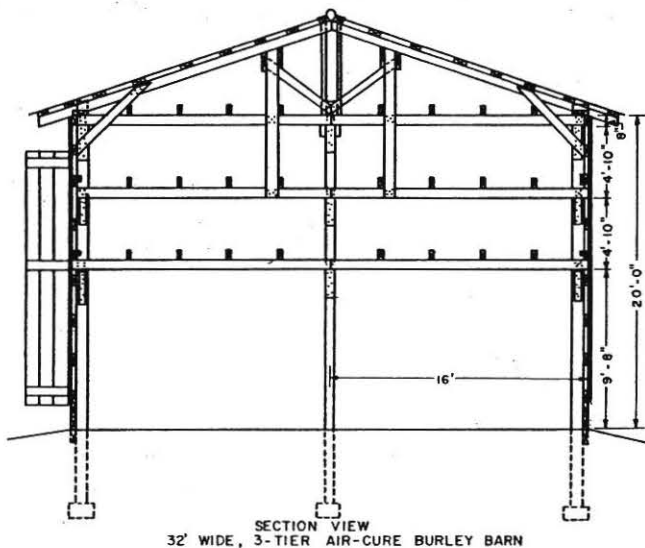

Figure 1A: 32' Version of Three-Tier Air-cure Tobacco Barn

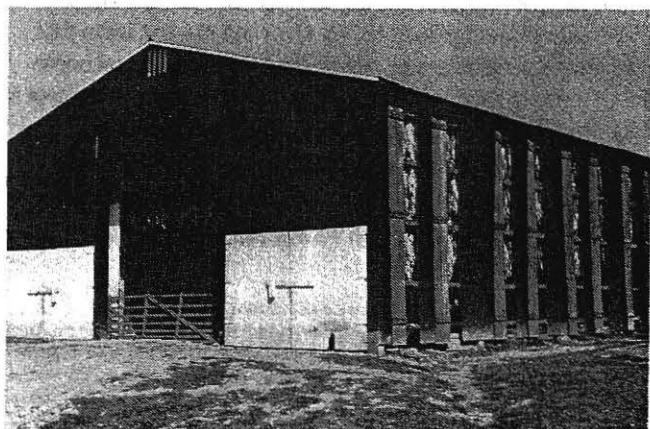

Figure 1B: 40' Version of Three-Tier Air-cure Tobacco Barn

5. Either wood or metal siding with hinged or track sidewall ventilator doors.
6. Preservative-treated wood or concrete curbing around the sidewall perimeter.
7. Alternate pole or post-pier construction details shown for two plans.

Three different blueprint plans are available to show alternate 32- and 40-foot wide designs. Operation and management of these barns are essentially the same as for all natural-air-cure conventional barns. More details on capacity, construction, and labor-saving features are in another publication titled *Conventional Air-Cure Tobacco Barns*. Housing and curing management guidelines are contained in the publication AGR-14, *Harvesting and Curing Burley Tobacco*.

Cable-Hoist System and Air-Cure Tobacco Barns

The cable-hoist system of tobacco transport and housing has proven to be a workable and cost-competitive method for new or converted air-cure barns to relieve the laborious and large crew-size tasks. The system permits one worker unassisted to place tobacco in a barn with a 40 to 50% overall reduction in labor-hours, including the field loading and transporting which can use two to four workers efficiently.

The cable-hoist system involves:

1. A special wooden beam fabricated of 12- or 14-foot lengths of 2 x 6, 2 x 8, 3 x 4 and/or 4 x 4 members bolted together so that it holds the equivalent of two rails of stick-harvested tobacco in a cantilevered position,
2. Modifications to a suitable conventional barn that include removing the tier rails, permanently suspending two small cables from the rafter framework for each two rails of width and adding support blocks to the cross-members to obtain support area standard dimensions for the beams. A vertical spacing of five feet more between cross members is necessary to prevent the stalks of one beam from jamming into the tip leaves of a beam of tobacco immediately above it.
3. Two special hydraulic-powered hoists controlled by hand switches that hook to the lower end of the cables and enable lifting and positioning each beam of tobacco into the barn.
4. Simple two-wheel trailer-carriers that support the wooden beams and enable field filling and transport to the barn for hoisting without further manual stick handling at the barn.

The two-stick wide beam width establishes a 7 1/2- to 8-foot wide unit which works best in 16-foot-wide driveways. New barn designs show 16-foot widths. Twelve-foot-wide driveways of older barns obviously cause a loss of one tier (4-foot) of width or allow putting only five plants per stick and placing the sticks further through the beam to obtain a two-stick width of six feet or less so two beams

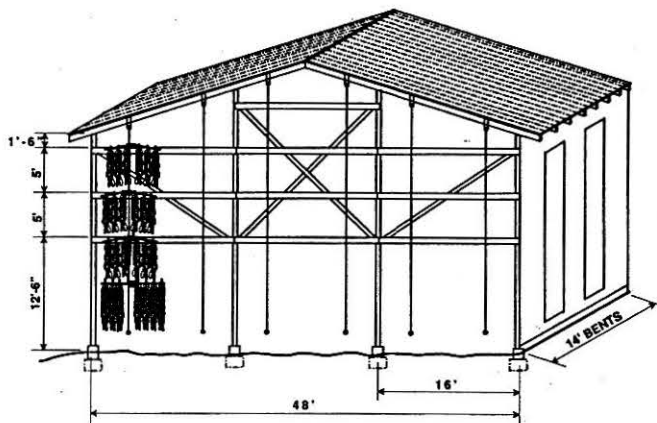

Figure 2: 48' Version of Three/Four-Tier, Plus Swing-Tier Air-Cure Tobacco Barn for Cable-Hoist System

will fit within a 12-foot driveway width. Fourteen-foot driveways would be handled similarly with five or six plants per stick.

Blueprints are available for 32'- and 48'-wide plans of post-pier and pole-type construction.

Further details on construction, operation, and management are available in a publication titled *Construction and Operational Guidelines for the Cable-Hoist Tobacco Housing System*.

Two-Tier Forced-Air Tobacco Barns

The two-tier forced-air design permits a more compact housing of tobacco with labor-saving and modified environmental control features. Specific features are:

1. Two-tier two-man housing for approximately 40% housing labor reduction and smaller crew size.
2. Closer spacing of tobacco on two-tiers permits about the same amount to be housed as in many three- to four-tier conventional barns.
3. Tier rails are spaced 5 1/2 feet apart vertically to minimize overlap and aid air movement.
4. Tier rails are spaced 38 to 40 inches apart horizontally to provide more uniform plant spacing and easier standing and housing for the worker.
5. High-volume fans bring in outside air and force it through the tobacco for curing in the burley design and draw out the inside air in the dark-fired design. Control of air flow provides more control over moisture removal and the curing process.
6. Supplemental heating equipment can be installed and used as needed in the burley design for reducing high humidity conditions.
7. Electrical controls permit semi-automatic operation to provide necessary air movement and curing control.
8. The barn design shows a 17 1/2-foot eave height, airtight (metal) roofing and siding, no braces among the tier rails to interfere with housing, and a trussed-roof construction for versatility.

Three blueprints show 32- and 40-foot-wide burley and 28-foot-wide dark-fired barn construction plans. Further

details on construction, operation, and management are contained in two separate publications titled, respectively, *Two-Tier Forced-Air Burley Tobacco Barns* and *Two-Tier Fan-Ventilated Dark-Fired Tobacco Barns*.

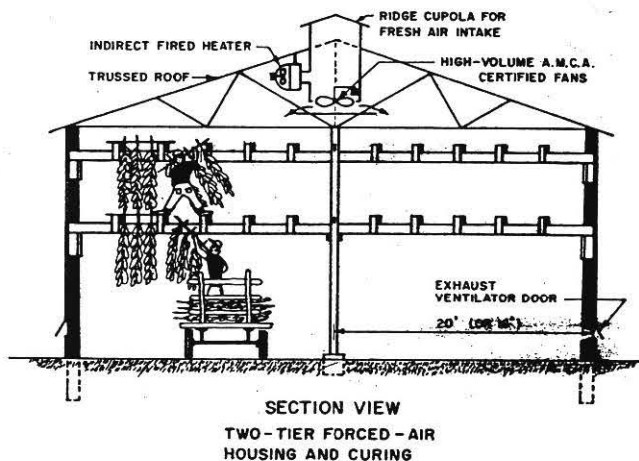

5. *Less damage to and losses of tobacco as hanging on frames eliminates piling and repetitive hand handling.*
6. *Many types of pole or steel buildings can be used for housing and curing, provided:*
 - *35-50% of sidewall can be opened for ventilation,*
 - *the building width or driveway is a modular multiple of frame size, and*
 - *15-foot overhead clearance exists for stacking frames two high.*

Use of the lower-cost untreated wooden frames precludes use of the barn during off-season because the frames should be stored inside for protection. Some of the frames could be constructed of more durable treated wood or steel to permit outside storage, thus freeing a portion of the barn for use during the non-curing season.

The frames are 6 1/2 to 7 feet high and 4'-2" wide overall with rails 5 1/2' to 6' high, 3'-10" wide, and 14' long. Approximately 90 board feet of lumber are required for construction. Each frame will hold 35-40 sticks of tobacco. Approximately 33-38 frames are required per acre of tobacco.

A larger farm loader and tractor with 4.5-foot-long tines spaced 4 to 5 feet apart and with vertical safety masts to prevent

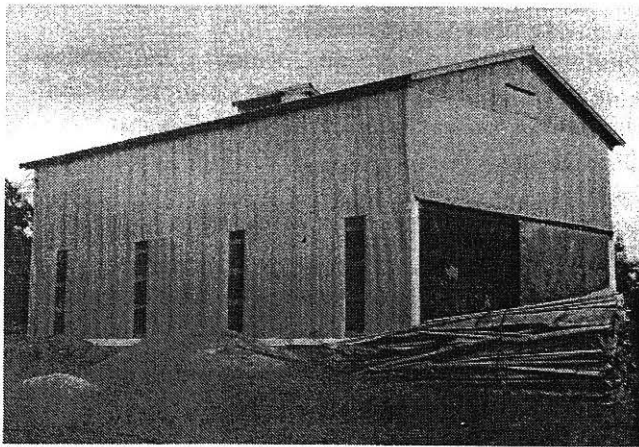
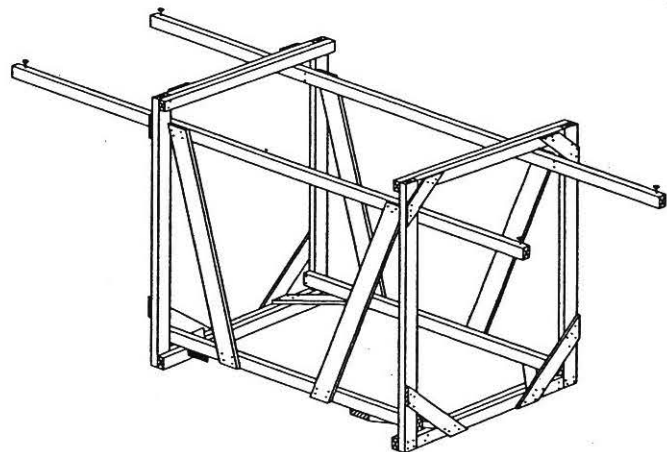

Figure 3: *Two-Tier Forced-Air Burley and Fan-Ventilated Dark-Fired Barns*



Wooden Portable Frames and Forklift Handling-Housing

The portable curing frame system was one of the first labor-saving and mechanical housing methods developed. The system uses wooden frames that are handled by a modified tractor front loader to enable transport to and distribution in the field for manual filling and field wilting, then transport and stacking into an open-interior barn for curing. The main features are:

1. *Approximately 40% reduction in housing labor.*
2. *A minimum crew size (one or two workers) to fill frames in the field, and one worker housing with the tractor forklift thereafter.*
3. *Safer working conditions because no workers are on tier rails in the barn.*
4. *Flexibility in housing because filled frames can be field wilted for several days without mud splatter damage and one worker can house on a convenient schedule.*

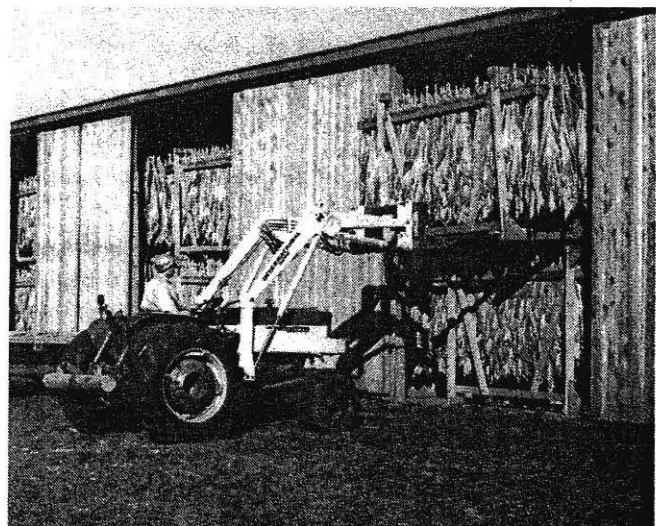

Figure 4: *Wooden Portable Curing Frame and Side-Entering Air-Cure Barn for Mechanical Housing*

frames from rolling over backwards is needed to handle and stack the frames. Normal loaders can stack frames two high, and special larger loaders could stack frames three high if barn clearance permits and the ground is level.

Special blueprints are available showing construction of these frames, side-entering pole or end-entering clear-span barns, transport wagons, and basic remodeling steps for suitable conventional barns.

The difficulty and cost of converting conventional barns and the off-season storage of empty frames where a farmer needs the barn driveways for other uses have been farmers' major objections to this system.

Further details on the portable curing frame system are contained in another publication titled *Handling and Housing Tobacco on Portable Curing Frames*.

Two-Tier Partially Enclosed Air-Cure Tobacco Barn

For situations where additional barn space of an economical but rather permanent type is required, a two-tier partially enclosed metal-covered design has been prepared. Several features of this design are:

1. Economy version of a barn for lower initial cost but capable of being enclosed in the future.
2. Two-tier, two-worker housing.
3. Metal roof and wood or metal siding from eave to the lower tier protects untreated wood and the tobacco during curing.
4. Plenty of ventilation with the open bottom, thus closer spacing of tobacco, can help compensate for two-tier height.
5. Two 14-foot driveways with 10-foot overhead clearance for normal housing methods and other off-season farm uses.
6. Capability of enclosing remainder of sidewall and adding doors in the future for the two-tier forced-air design, or adding adequate sidewall ventilation doors and adjusting spacing for a two-tier air-cure version.

Of course, any of the other three- to four-tier air-cure barns could be built in this manner for initial economy and later closure. More details are contained in a separate publication titled *Two-Tier Partially Enclosed Air-Cure Tobacco Barn*.

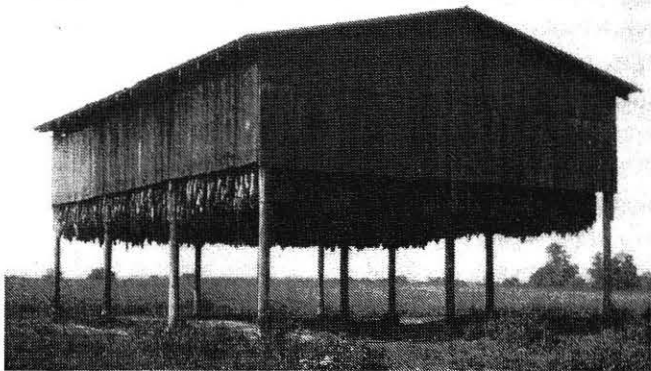

Figure 5: Economy Two-Tier Partially Enclosed Air-Cure Barn

One-Tier Plastic-Covered Field Curing Structure

A lower-cost curing facility for expansion or barn replacement uses can be a plastic-covered field structure. Curing results in these structures have been comparable to conventional barn curing over several years with only the tip grades showing some discoloration. This problem can generally be avoided with a high, well-drained, and sodded site with good air movement. The main features of this structure and housing are:

1. Low-cost using readily available materials and plastic roof.
2. Quick, easy construction.
3. Easy one-man housing directly from a wagon or truck bed or with cantilever beams and hydraulic trailer-carrier or cable-hoist lift.
4. Black 6-mil plastic provides satisfactory roof coverage for one season or sometimes longer. Newer woven or reinforced plastic films are being tested and could serve for two to three years or longer.

Other construction and management details are given in a separate publication titled *One-Tier Plastic-Covered Tobacco Curing Structure*.

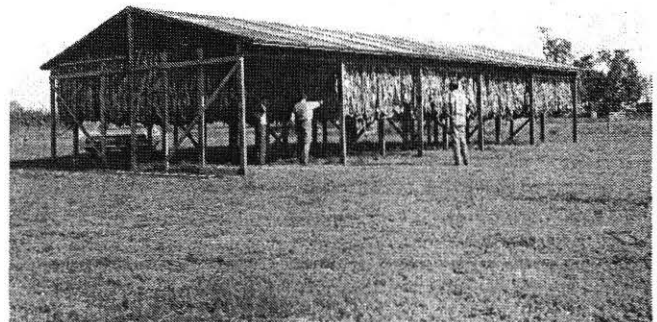

Figure 6: One-Tier Plastic Covered Field Curing Structure

Machinery Shed with Removable Tier-Rails for Small Acreages

Some mini-farm or country-estate owners may need only enough tobacco housing space for up to 1,000-1,500 pounds of quota. A plan for a 30 x 40-foot (or other length) open-sided (or

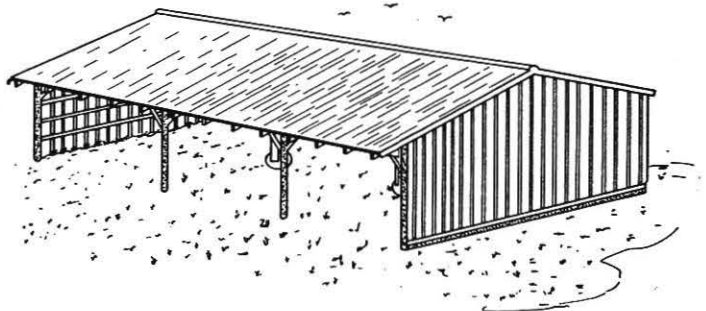

Figure 7: 30-foot-wide Machinery Shed with Removable Tier-Rails for Small Acreages

with track doors) type pole-frame garage or equipment shed has been prepared to provide such tobacco housing and alternative year-round uses. The plan shows "two-tier" type tobacco housing with the top tier being 2 x 6 rails extending from eave-to-eave at a 12-foot height. The second tier consists of 2 x 6 "slip-rails" and some temporary posts which form a 6-foot-high tier for hanging tobacco and which can be removed and stored the remainder of the year to allow for other "open-interior" uses.

Stripping Rooms

A good stripping room is mandatory for most producers for stripping and market preparation tasks. Some smaller producers can get by with temporarily enclosing a portion of the barn with plastic, tarps, etc., and using a fold-up bench and portable heat. Or, they can haul the unstripped tobacco to a more suitable location.

Any permanent stripping room can also serve as a tool room, small workshop, or storage area the remainder of the year if suitably arranged and conveniently located.

Three stripping room plans available are:

1. 12' x 20' with shed-type roof when attached to the side of the barn and with a 4-foot-wide exterior passage door.
2. 18' x 24' with gable-type roof when attached to the side of the barn and with a 4-foot exterior passage door and overhead garage-type door for larger equipment access.
3. 30' x 50', or larger, drive-through facility with pole-type construction and 12- or 16-foot-wide overhead doors. This "drive-in" stripping facility can be attached to a barn or separately located for centralized stripping. The attached side sheds, if added, can be used for tobacco storage, tool rooms, work shops, farm office, etc.

General insulation, electrical circuits, supplemental heat, and concrete floor options are indicated in all plans so the owner can add these if desired. An all-weather access roadway would be needed if the stripping room is to be used for year-round purposes.

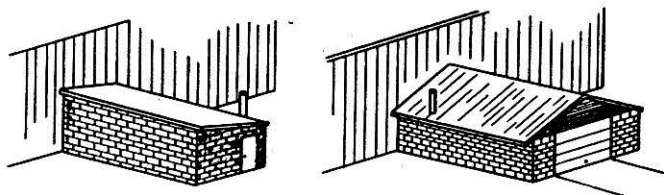

Figure 8: 12' x 20' Shed-Type and 18' x 24' Gable-Type Stripping Rooms Attached to Barns

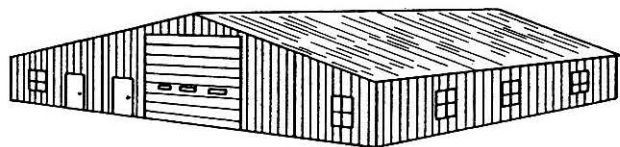

Figure 9: 30' x 50' "Drive-in" Stripping Room with Attached Storage, Office, or Work Rooms

Renovating and Remodeling Older Barns

Many of the 200,000 burley producers have curing barns that are generally in good structural condition. With some remodeling, they can often be improved to make housing easier and/or to aid the curing process. A few possibilities are described here.

Good burley curing requires lots of natural air. Be sure ventilator doors or equivalent openings equal one-third to one-half the barn sidewall. Keep these vent doors in good repair so they can be opened and closed as required. Whenever possible, remove obstructions such as trees, bushes, hay stacked in attached sheds, etc., that block prevailing winds.

Install full-width driveway doors to accommodate wagon access and increase housing efficiency. An amazing number of people still hand tobacco from the driveway to the sheds and up into the barn which takes an extra worker or two.

Provide for supplemental heat or fans where natural ventilation is inadequate. These methods will help wilt big green tobacco and aid curing of tightly housed tobacco, or of tobacco in barns having poor ventilation.

Many producers have found that in older barns, where tiers are only 3 or 3 1/2 feet apart vertically, better curing results when tobacco is housed on every other tier rail. This eliminates overlapping and produces better air movement.

Structurally sound conventional barns can be modified for the cable-hoist system or portable frame housing for labor-saving benefits. Specific details of these procedures are contained in the publications on these methods.

Plans and Blueprints Available

An attached listing shows plans and blueprints currently available for tobacco barns, stripping rooms, and rail wagons.

Labor Comparisons of Various Type Tobacco Barns

Extensive labor studies and analyses over the years on labor requirements and efficiencies in filling tobacco barns have been summarized in a chart shown at Figure 10.

The chart presents comparative labor, cost, and efficiency data for several combinations of one- to six-tier style barns using one to four workers, the cable-hoist method, and the trailer-carrier for the field structure.

The various entries are explained below:

Efficiency Adjustment - The basic labor data are taken for a steady, uninterrupted working crew. The efficiency adjustment allows for interruptions and lost time in climbing, filling out rails, etc., which reduce productivity and increase hours and cost.

Housing Rate, Sticks/Hour - The rate at which sticks of harvested tobacco are placed into the barn from the transport wagon or trailer for the **total crew** involved.

Housing Rate, Sticks/Worker-Hour - The rate at which sticks of harvested tobacco are placed into the barn, as above, **per worker** involved.

Labor Required, Worker-Hours/Acre - The total "worker-hours," or "payroll time," to place 1,350 sticks (1 acre equivalent) in the barn.

LIST OF PLANS FOR TOBACCO BARNS AND EQUIPMENT

Many of these plans are on a web site: www.bae.uky.edu/ext/tobacco as a printable version or can be ordered from: Plan Service, Agricultural Engineering Department, University of Kentucky, Lexington, KY 40546-0276. The number of sheets for each plan is indicated. the cost per plan is \$2.00 for 1 and 2 sheets, \$3.00 for 3 and 4 sheets, \$4.00 for 5 or more sheets. A computerized Bill of Materials and cost estimate is available upon request. Please specify plan number for all plans, and width and length for barn plans.

BURLEY AND DARK AIR-CURED BARNs:

- 735-26A Three/Four Tier Air-Cure Barn, (4 sheets). Post-pier-rafter type, 2 driveways, wood or metal siding, with sidewall ventilation doors, 28- or 32-ft. wide x 14-ft. bents, 330-ft. tier rail space per bent for 32-ft. width.
- 735-26C Three Tier Air-Cure Barn, (3 sheets). Post-pier-rafter type, 2 driveways, wood or metal siding, with sidewall ventilation doors, 32-ft. wide x 14-ft. bents, for cable-hoist housing method, holds 12 to 16 'beams' per bent (equal to 24 to 32 tier rail spaces, 228 to 384-ft. tier rail space).
- 735-27A Three/Four Tier Air-Cure Barn, (4 sheets). Post-pier-rafter type, 3 driveways, wood or metal siding, with sidewall ventilation doors, 40- or 48-ft. wide x 14-ft. bents, 550-ft. tier rail space per bent for 40-ft. width.
- 735-27C Three/Four Tier Air-Cure Barn, (4 sheets). Post-pier-rafter type, 3 driveways, wood or metal siding, with sidewall ventilation doors, 48-ft. wide x 14-ft. bents, for cable-hoist housing method, holds 20 to 26 'beams' per bent (equal to 40 to 52 tier rail spaces, 480 to 624-ft. tier rail space).
- 735-28A Three/Four Tier Air-Cure Barn, (3 sheets). Post-rafter type, 2 driveways, wood or metal siding, with sidewall ventilation doors, 28- or 32-ft. wide x 14-ft. bents, 330-ft. tier rail space per bent for 32-ft. width.
- 735-28C Three Tier Air-Cure Barn, (3 sheets). Pole-rafter type, 2 driveways, wood or metal siding, with sidewall ventilation doors, 32-ft. wide x 14-ft. bents, for cable-hoist housing method, holds 12 to 16 'beams' per bent (equal to 24 to 32 tier rail spaces, 288 to 384-ft. tier rail space).
- 735-29A Three/Four Tier Air-Cure Barn, (3 sheets). Pole-rafter type, 3 driveways, wood or metal siding, with sidewall ventilation doors, 40- or 48-ft. wide x 14-ft. bents, 550-ft. tier rail space per bent for 40-ft. width.
- 735-29B Two/Three-Tier Air-Cure Barn, (4 sheets). Pole-rafter type, 3 driveways, wood or metal siding, with sidewall ventilation doors, 40-ft. wide x 14-ft. bents, 385-ft. tier rail space per bent for 40-ft width.

- 735-29C Three Tier Air-Cure Barn, (3 sheets). Pole-rafter type, 3 driveways, wood or metal siding, with sidewall ventilation doors, 48-ft. wide x 14-ft. bents, for cable-hoist housing method, holds 20 to 26 'beams' per bent (equal to 40 to 52 tier rail spaces, 480 to 624-ft. tier rail space).
- 735-30 Three Tier Air-Cure Barn, (4 sheets). Pole-trussed roof type, 2 driveways, wood or metal siding, with sidewall ventilation doors, 40-ft. wide x 12-ft. bents, 412-ft. tier rail space per bent for 40-ft. width.
- 735-34 Two-Tier Air-Cure Barn, (2 sheets). Pole-rafter type, partially enclosed sides, 28-ft. wide x 14-ft. bents, 192-ft. tier space per bent.
- 735-34A Two-Tier Plus 3rd Removable Lower Tier Air-Cure Barn, (2 sheets). Pole-rafter type, partially enclosed sides, 32-ft. wide x 14-ft. bents, 336-ft. tier space per bent.
- 741-7 Thirty-foot Machinery Shed w/Removable Tier Rails, (2 sheets). Two-tier tobacco housing.

TWO-TIER FORCED-AIR BURLEY BARNS:

- 735-32 Two-Tier Forced-Air Burley Barn, (8 sheets). Pole-trussed roof type, 2 driveways, with fan ventilation and specification details, 32-ft. wide x 12-ft. bents, 240-ft. tier rail space per bent.
- 735-33 Two-Tier Forced-Air Burley Barn, (8 sheets). Pole-trussed roof type, 2 driveways, with fan ventilation and specification details, 40-ft. wide x 12-ft. bents, 288-ft. tier rail space per bent.

DARK-FIRED BARNS:

- 735-31 Three-Tier Fan-Ventilated Dark-Fired Barn, (6 sheets). Pole-trussed roof type, metal siding, concrete perimeter foundation wall, 2 driveways, hinged driveway doors, exhaust fan ventilated, 28-ft. or 32-ft. wide x 12-ft. bents, 288-ft. tier space per bent for 3-tier, 32-ft. wide.
- 735-31C Three-Tier Fan-Ventilated Dark-Fired Barn, (3 sheets). Post-pier rafter type, metal siding, concrete perimeter foundation wall, 2 driveways, hinged driveway doors, exhaust fan ventilated, 32-ft. wide x 14-ft. bents, for cable hoist housing method, holds 12 'beams' per bent (equal to 24 tier rail spaces, 288-ft. tier rail space).

PORTABLE CURING FRAMES AND AIR-CURE BARNS:

- 735-35 Portable Tobacco Curing Frame (3 sheets). Wooden construction, 1-rail wide x 12-ft. or 14-ft. long, fork-lift handled, with materials list, jig for construction, and wagon modifications for transporting shown, 30-34 sticks per frame.
- 735-36 Portable Tobacco curing Frame (1 sheet). Angle-iron welded steel construction, 1-rail wide x 12-ft. or 24-ft. long, fork-lift handled, with materials list, 30-34 sticks per frame.

1 TIER 1 WKR. 2 TIERS 2 WKRS. 2 TIERS 3 WKRS. 3 TIERS 3 WKRS. 3-4 TIERS 1 WKR. 4 TIERS 3 WKRS. 4 TIERS 4 WKRS. 5 TIERS 4 WKRS. 6 TIERS 4 WKRS.

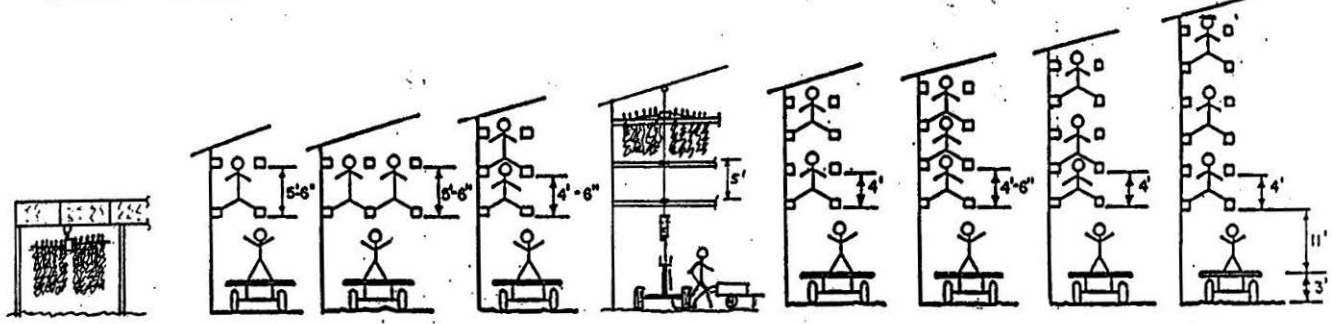

EFFICIENCY ADJ.		-20%	-25%	-30%	-20%	-30%	-30%	-30%	-30%	
HOUSING RATE	<u>STICKS</u> HOUSING HOUR	1320	360 (300)	720 (576)	432 (332)	648 (540)	480 (369)	480 (369)	514 (395)	400 (308)
HOUSING RATE	<u>STICKS</u> WK-HR	1320	180 (150)	240 (192)	144 (111)	648 (540)	160 (123)	120 (92)	129 (99)	100 (77)
LABOR REQUIRED	<u>WK-HR</u> ACRE	1.0	7.5 (9)	5.7 (7.2)	9.4 (12.2)	2.1 (2.5)	8.5 (11.1)	11.3 (14.7)	10.5 (13.7)	13.5 (17.6)
HUMAN ENERGY	(MAN-LBS)	Neg.	324K	324K	389K	138.0	474K	646K	508K	578K
HOUSING TIME	(HRS/AC)	1.0	3.8 (4.6)	1.9 (2.4)	3.2 (4.2)	2.1 (2.5)	2.8 (3.6)	2.8 (3.6)	2.7 (3.5)	3.4 (4.4)
LABOR COST	(\$/AC)	\$6.50	\$48.75 (\$58.50)	\$37.05 (46.80)	\$61.10 (79.30)	\$13.65 (\$16.25)	\$55.25 (72.15)	\$73.45 (\$95.55)	\$68.25 (\$89.05)	\$87.75 (\$114.40)
IDLE* TIME	(\$/AC)	0.00	\$12.19 25% (\$14.62)	\$0.00 0%	\$15.89 26% (\$20.62)	\$0.00 0%	\$11.16 22% (\$15.87)	\$18.36 25% (\$23.89)	\$11.60 17% (\$15.14)	\$28.96 33% (\$37.75)

*By workers in barn.

Above computations based on 5 seconds to grab-and-pass a stick and 10 seconds to place-and-spread (video tape of farm crew yielded 3.65 and 6.10 seconds, respectively, for uninterrupted housing process, \$6.50/hr. Labor rate 1,350 sticks/Ac.

GAD, U.KY
Rev. 12/18/90

FIGURE 10: LABOR, COST, AND EFFICIENCY COMPARISONS FOR VARIOUS TOBACCO HOUSING FACILITIES.

- 735-40 Side-Entering Barn for Portable Frames, (2 sheets). Pole-rafter type, wood or metal siding, with sliding sidewall/driveway doors on alternate bents, 42-ft. wide x 16-ft. bents, for 14-ft. frames, 24 frames per bent.
- 735-41 Side-Entering Barn for Portable Frames, (4 sheets). Pole-trussed roof-type, wood or metal siding, with sidewall ventilation doors, sliding end-wall driveway doors, 46-ft. wide x 12-ft. bents, for 14-ft. frames.

FIELD CURING STRUCTURES:

This listing contains literature with drawings within the publication; therefore there are no separate blueprints.

- AEN-74 One-Tier Plastic Covered Tobacco Curing Structure, tier rail design. 28 ft. wide.
- AEN-80 High Tensile Wire or Cable Tobacco Curing Structure.
- AEN-85 Post-Tier Rail and Typar® or Metal-Covered Tobacco Field Curing Structures.
- AEN-86 Moveable Tobacco Curing Frames.
- AEU-82 A Field Curing Structure and Mechanized Housing System for Burley Tobacco, 28 ft. wide.
- ID-38 Economy Bale Press.
- ID-39 Packaging and Handling Burley Tobacco in Bales at the Farm.
- ID-116 Low-Cost Post-Row Field Tobacco Curing Framework. Two sticks wide, cantilever stick support, plastic cover.

STRIPPING ROOMS:

- 735-6 Drive-Thru Tobacco Stripping Room, (4 sheets). Pole-frame metal covered drive-through stripping room with benches on each side, optional side sheds for added storage, tool rooms, shop, office, etc., 30-ft. wide x 36-ft. long with 12-ft. wide sheds, additional lengths in 12-ft. increments.
- 735-12A Tobacco Stripping Room, (1 sheet). Wood frame or concrete block, stripping bench, lights, heat shown, 12-ft. x 20 ft.
- 735-23A Tobacco Stripping Room, (1 sheet). Wood frame or concrete block, stripping bench, lights, heat shown, 18-ft. x 24-ft.

HAULING WAGONS:

- 735-50 Tobacco Hauling Trailer, (1 sheet). Two-wheel, pipe-frame, 2 rail wide x 21-ft. long, with materials list.
- 735-51 Tobacco Hauling Trailer, (1 sheet). Frame of channel-iron steel for 4-wheel farm wagon chassis, 2-rails wide x 24-ft. long, with materials list.
- 735-52 Tobacco Hauling Wagon, (1 sheet). Frame of channel-iron steel for 4-wheel farm wagon or old truck/bus chassis, 3-rails wide x 2-rails high, 24-ft. long, with materials list.
- 735-53 Tobacco Trailer-Carrier for Cable-Hoist Beam, (2 sheets). Two-wheel, pipe-frame, 14'-6" long, holds 1 beam, with materials list.
- 735-54 Tobacco Trailer-Carrier (22 - 8½ x 11 sheets) Hydraulic cylinder lift for cantilever beam and one-tier field curing structure, two-wheel, tubular steel construction, 34-ft. long, holds two 14-ft. beams, with materials list and parts details.