



University of Kentucky
UKnowledge

Agricultural Engineering Extension Publications

Biosystems and Agricultural Engineering

4-2005

Moveable Tobacco Curing Frames

George A. Duncan

University of Kentucky, gduncan@uky.edu

Larry D. Swetnam

University of Kentucky, larry.swetnam@uky.edu

Linus R. Walton

University of Kentucky, lwalton@ca.uky.edu

Right click to open a feedback form in a new tab to let us know how this document benefits you.

Follow this and additional works at: https://uknowledge.uky.edu/aen_reports

 Part of the [Bioresource and Agricultural Engineering Commons](#)

Repository Citation

Duncan, George A.; Swetnam, Larry D.; and Walton, Linus R., "Moveable Tobacco Curing Frames" (2005). *Agricultural Engineering Extension Publications*. 3.

https://uknowledge.uky.edu/aen_reports/3

This Report is brought to you for free and open access by the Biosystems and Agricultural Engineering at UKnowledge. It has been accepted for inclusion in Agricultural Engineering Extension Publications by an authorized administrator of UKnowledge. For more information, please contact UKnowledge@lsv.uky.edu.

Moveable Tobacco Curing Frames

George Duncan, Larry Swetnam, and Linus Walton

Moveable (or portable) curing frames offer the tobacco grower another option for successfully reducing labor and costs for producing air-cured tobacco. Reducing labor and costs is essential to continuing profitable tobacco production.

Two designs that use the cantilever-beam concept for supporting two rails of stick tobacco on a central beam are shown and explained in this publication. Further details of construction and covering are shown in the following drawings.

Advantages

Low-cost, low-labor, sturdy, and moveable tobacco curing frames have been studied extensively by agricultural engineers at the University of Kentucky for many years. As a result of these studies, moveable curing frames have been shown to:

- provide a means of reducing the curing structure and labor costs,
- cure tobacco equivalent to normal barn curing, and
- offer a means of being located close to the field.

Being able to locate the curing frames close to the field reduces transport time during the busy harvest period. Filling directly from the stick row reduces conventional loading and unloading time and expense. Working at ground level eliminates the dangers of climbing and working on tier rails in the tall barns.

Precautions

Moveable curing frames have some additional weather risks that can be minimized by diligent application and management of the plastic and by anchoring the frames against high winds. These frames *must be anchored or protected* against the strong winds of fall weather.



Figure 1. Tobacco cured in moveable curing frames.

Managing the Plastic

Covering the structure with plastic is a task similar to covering a post-row structure. It is a good idea to choose a day with calm winds and to have three to four helpers on hand.

Although 4-mil plastic was used in this experiment, further experiments showed that the tougher 6-mil black plastic would be worth the extra cost to be more resistant to tearing. The top edges at the ends of the frames need some form of protection to help reduce stress points and tearing of the plastic. Use small pieces of folded plastic or other soft material to form and attach a padded cover over the wood edges.

Anchoring the Frames

One way to anchor the frames against high winds is to drive a 2x2x18-inch stake, or similar size pipe, at the edge of the base of the frames on the side *from which the winds are expected to blow* and use double or triple strands of plastic-type baler twine to secure the post and rail of the frame to the stake at ground level as shown in the drawings. Plastic baler twine is recommended over the sisal types, as other studies have shown that the stranded sisal type baler twine unraveled and failed during the fall period of continual wind forces on the twine. One anchor per frame was adequate for some winds in subsequent years, but an anchor per leg of the frames is more assured of anchoring in moist soil during heavy rains and strong winds.

Double-strand twine is recommended over the nailing strips, unless the nailing strips are secured with 4d to 6d deformed shank nails.

Frame Designs

Two moveable curing frame designs were tested at the University of Kentucky Woodford County Research Farm in the fall of 1996. They included a basic design (Figures 2-5) and a bow-top design (Figures 6-9). These frames were based on a similar design first tested in 1983-84 studies (Walton et al., 1985).

Basic Design

The basic frame design consists of three 14-foot 2x4s nailed to the edge of two 8-foot 2x6 legs to form the cantilever stick support beam. A 6-foot 2x6 base was nailed to the bottom end of the 2x6 legs to provide a free-standing frame. Two 2x4s were nailed across the top ends of the 2x6 legs to provide a lifting rail and plastic support members (see notes about using screws and reinforcements for this attachment). These lifting members enabled a tractor front-loader rated for 1,200- to 1,500-pound loads to move empty and filled frames.

The smaller bottom tines of a round bale mover on a front-mounted tractor loader were successfully used to move the frames in this study. (*Note:* The tines need to be fully extended under the top lift members to avoid bending the tines. Do not lift out on the end of the small tines.)

One group of 20 frames of the design shown in Figure 2 were transported to the field with the tractor loader and filled directly from the stick rows of tobacco. After all were filled, the frames were moved to a nearby sod area and aligned end to end as shown at Figure 3.

A poly rope was stretched across the top of each row of frames to help support the plastic covering between frames. In this experiment, 4-mil black plastic was used to cover the frames about one week after filling and before any rain. New recommendations suggest using 6-mil black plastic for more strength. The plastic was secured to the frames with plastic baler twine looped over, around, and under the frames and tied to the support members.

Figure 2. Basic design, moveable tobacco curing frame.

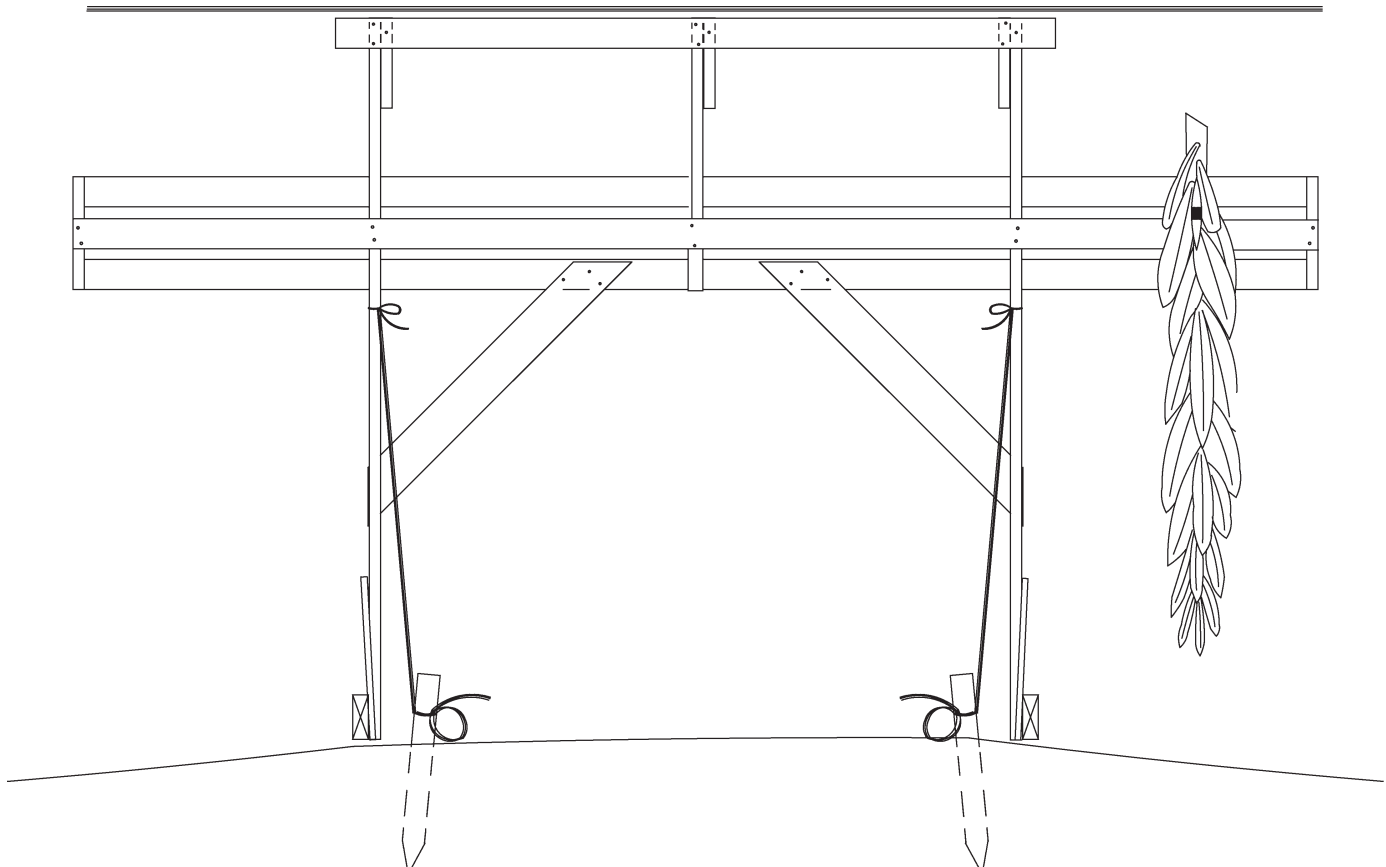

Figure 3. Basic design frames set end to end for covering and curing, top elevation.

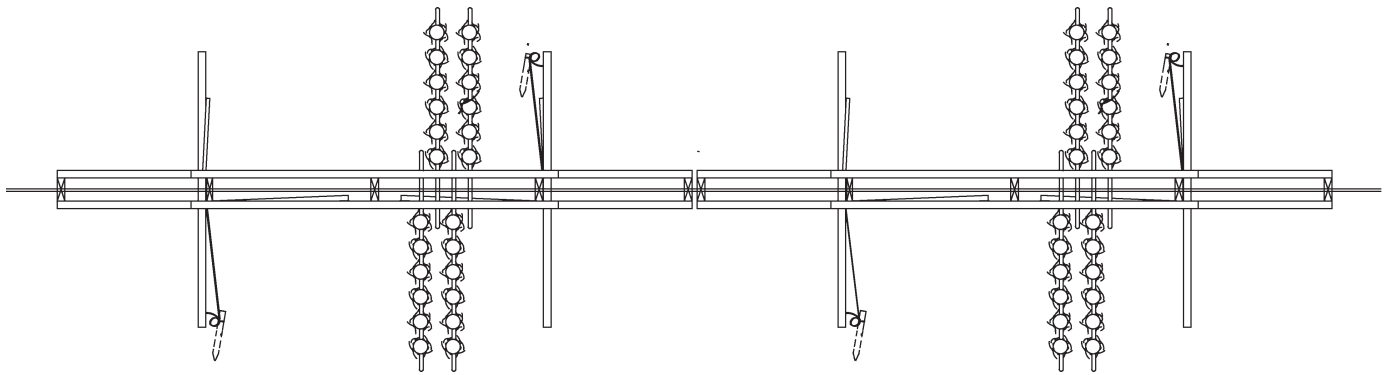
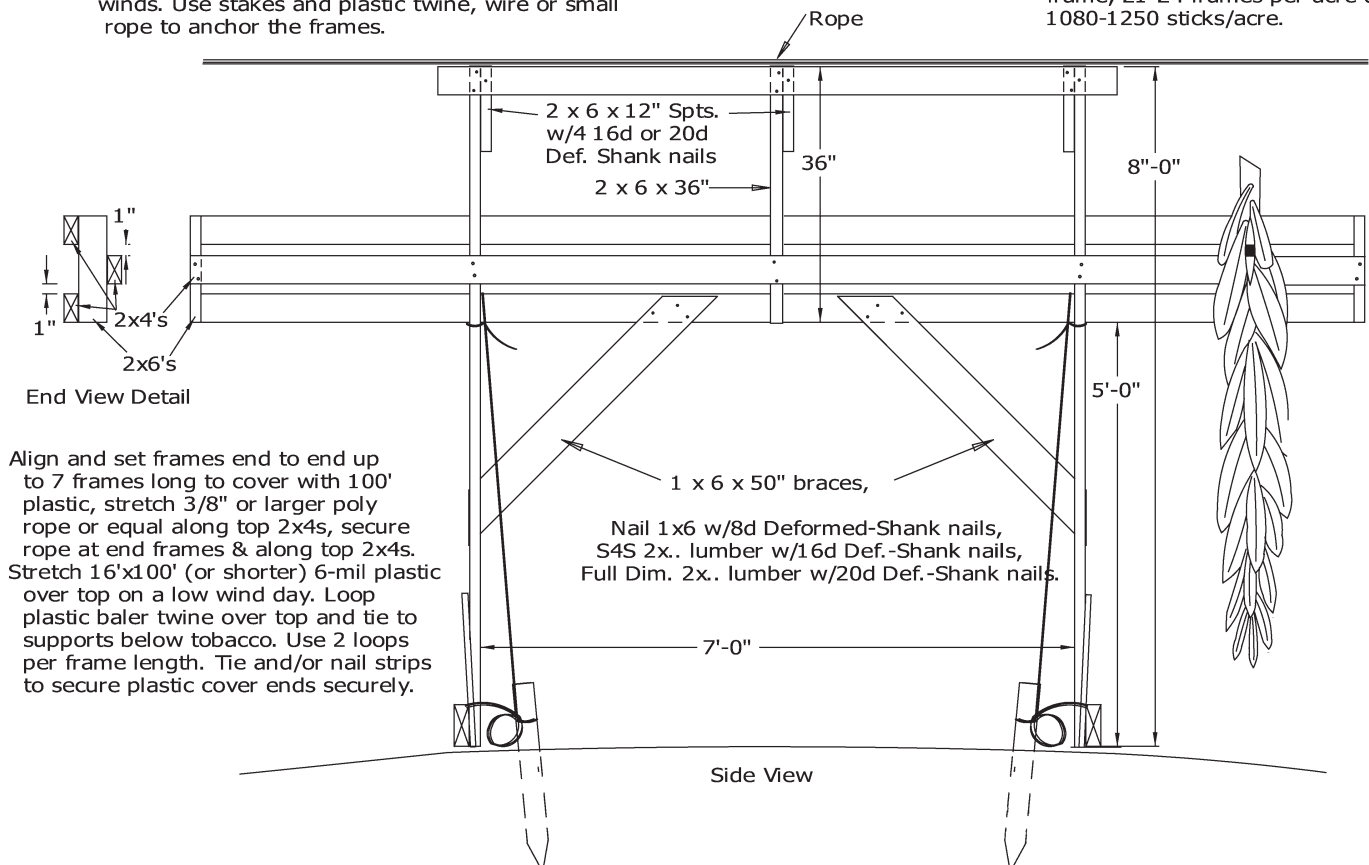

Figure 4. Basic design, side elevation.

WARNING: This frame design will turn over in high winds. Use stakes and plastic twine, wire or small rope to anchor the frames.

Use 48-52 sticks maximum per frame, 21-24 frames per acre at 1080-1250 sticks/acre.



Align and set frames end to end up to 7 frames long to cover with 100' plastic, stretch 3/8" or larger poly rope or equal along top 2x4s, secure rope at end frames & along top 2x4s. Stretch 16'x100' (or shorter) 6-mil plastic over top on a low wind day. Loop plastic baler twine over top and tie to supports below tobacco. Use 2 loops per frame length. Tie and/or nail strips to secure plastic cover ends securely.

Figure 5. Basic design, end elevation.

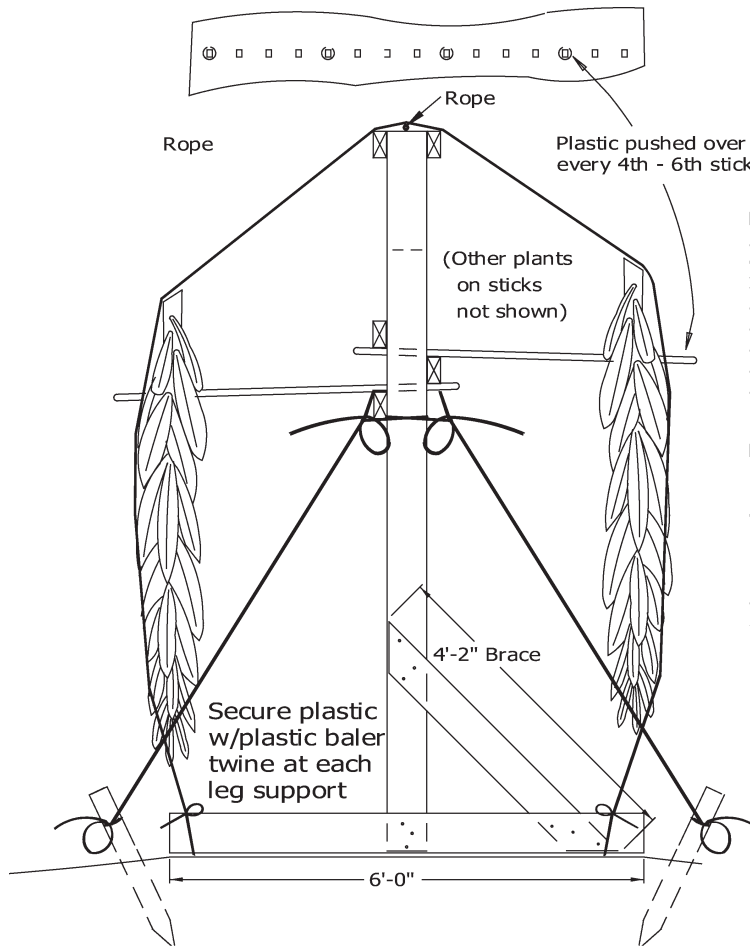

- Materials (S4S or Full Dimension Lumber)
- 2 x 4 x 14 ft 3 ea Rails, Full Dim. lumber
 - or 2 x 4 x 12 ft 3 ea Rails, S4S lumber
 - 1 x 6 x 8 ft 2 ea Braces (or 1 16')
 - 2 x 6 x 12 ft 1 ea Bottom Spts.
 - 2 x 6 x 10 ft 1 ea Ends, Middle & Spt. Blks
 - 2 x 6 x 8 ft 2 ea Legs
 - 2 x 4 8 ft 2 ea Top Lift Rails
 - 2 x 2 x 18 inch 1 or 2 ea, stakes
- (Above lumber = approx. 86 bd. ft.)

- Deformed Shank Nails:
- 3.5" (16d) for S4S lumber - 1/2 lb
 - 2.0" (6d) for S4S braces - 1/4 lb
- or
- 4.0" (20d) for full dim. lumber
 - 2.5" (8d) for full dim. braces - 1/4 lb

3/8" or 1/2" Rope, Plastic Baler Twine - Length as req'd
 All lumber should be pressure treated for longer life.

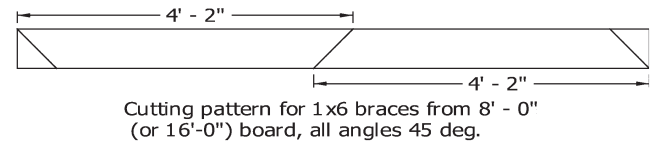

Bow-Top Design

Another group of frames of the design shown in Figure 6 had a 15-foot 1x4 bowed and nailed over the top. These frames were aligned side by side (Figure 7) on a sod area near the field and filled from flat-bed wagonloads of tobacco hauled from the nearby field. The 1x4 was nailed to the top of the legs and down to the ends of the stick support members to form an additional support for the plastic covering. The plastic was held to the 1x4 bow with small nailing strips (1/4- x 1-inch plywood strips) and 4d nails or double-strand twine pulled snugly over the bow and secured at the ends. The nailing strips had 4d nails about every 18 inches from the edge of the frame up to as far as a worker could reach from a stepladder (about 5 feet).

In these experiments, the strong winds of October caused serious damage to the plastic during the curing period and literally blew over each group of frames at different times. The blow-over occurred after the tobacco had nearly cured and lost so much of the green weight that the frames were too light and top-heavy to withstand the broadside winds on the ridge-top location. (The wind gusts were 35 to 40 miles per hour or higher, as reported by the National Weather Service.) Other wind damage to buildings and property also occurred around the state at that time. The uplift of the wind on the plastic literally pulled the wooden strip and 4d nails from the 1x4 pine bow.

Figure 6. Bow-top design, moveable tobacco curing frame.

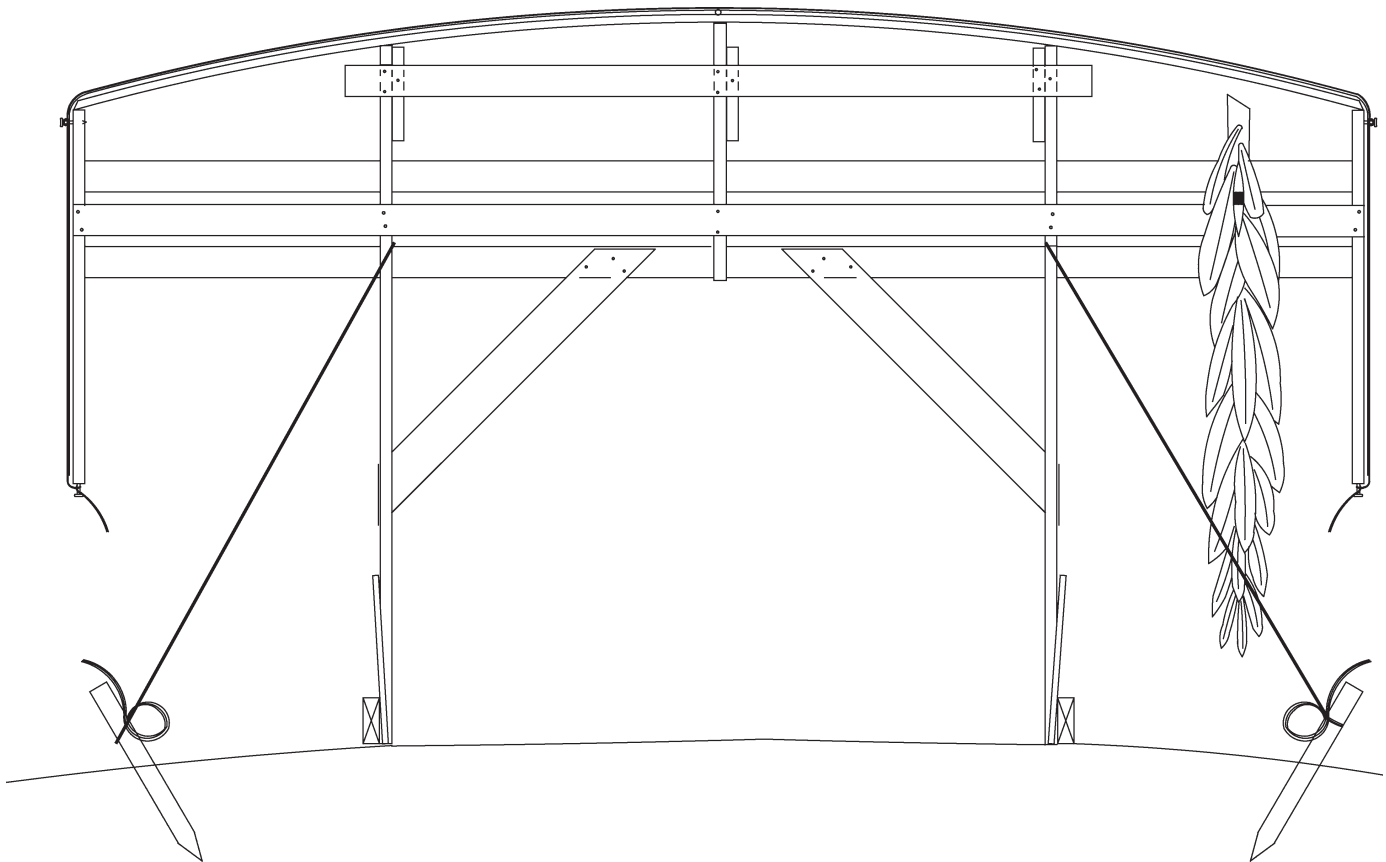



Figure 7. Bow-top design frames set side by side for covering and curing, top elevation.

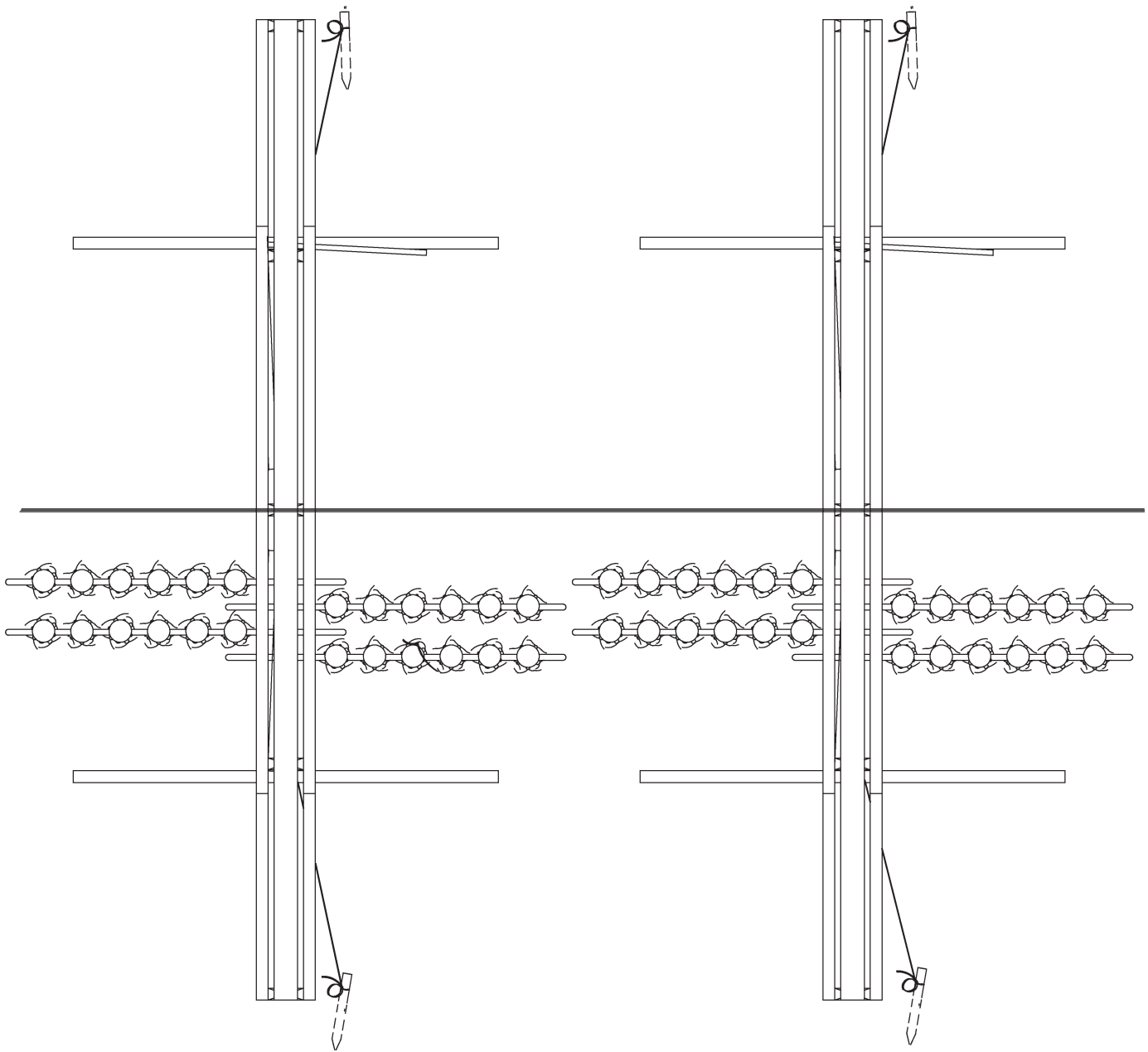

Figure 8. Bow-top design, side elevation.

WARNING: This frame design will turn over in high winds. Use stakes and plastic twine, wire or small rope to anchor the frames.

Use 48-52 sticks maximum per frame, 21-24 frames per acre at 1080-1250 sticks/acre.

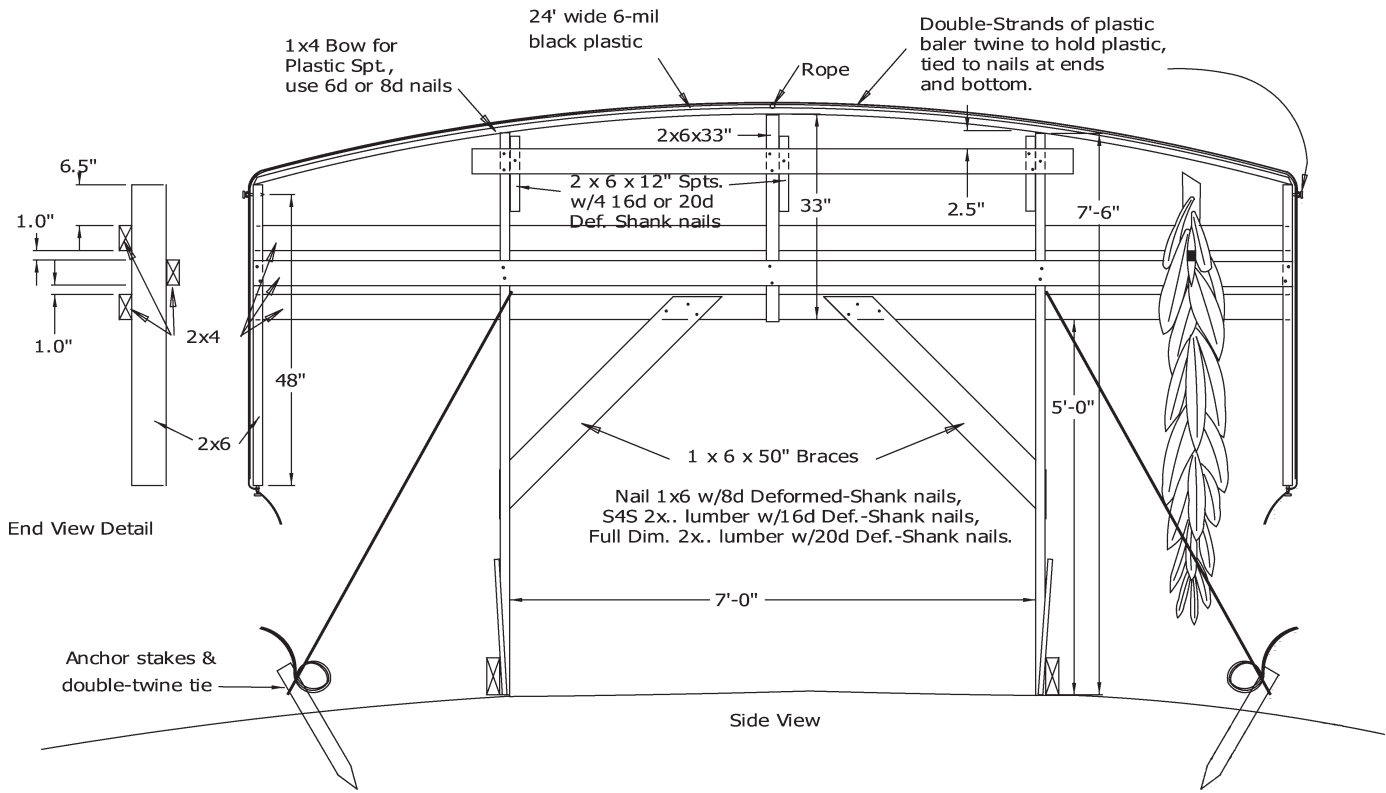
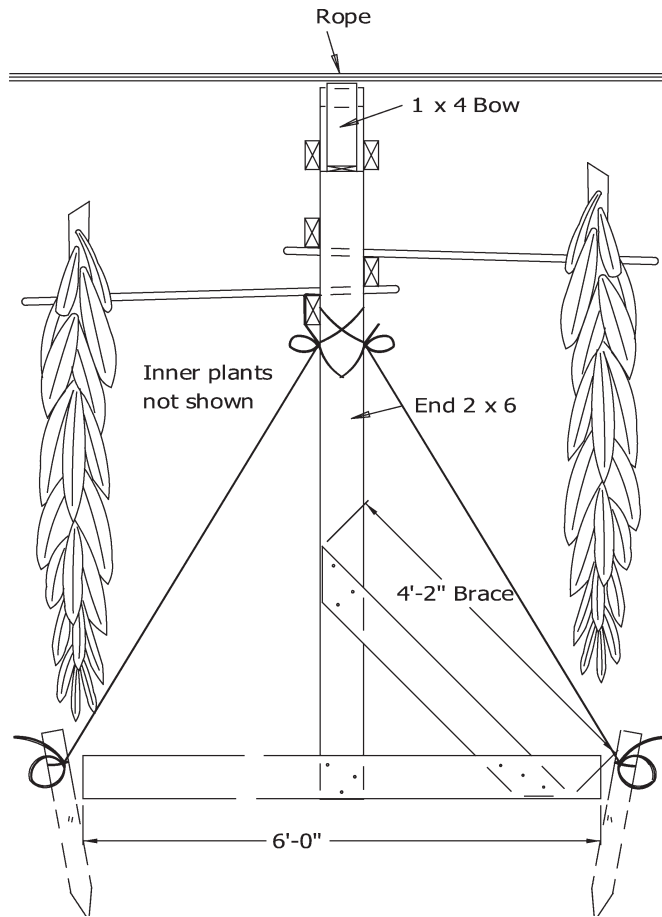

Figure 9. Bow-top design, end elevation.



Materials (S4S or Full Dimension Lumber)
 2 x 4 x 14 ft 3 ea Rails, Full Dim. lumber
 or 2 x 4 x 12 ft 3 ea Rails, S4S lumber
 1 x 6 x 8 ft 2 ea Braces (or 1 16')
 2 x 6 x 12 ft 1 ea Bottom Spts.
 2 x 6 x 8 ft 1 ea End Spts.
 2 x 6 x 8 ft 2 ea Legs
 2 x 6 x 6 ft 1 ea Center & Top Blocks
 2 x 4 x 8 ft 2 ea Top Lift Rails
 1 x 4 x 16 ft 1 ea Top Bow
 2 x 2 x 18 inch 1 or 2 ea, stakes
 (Above lumber = approx. 95 bd. ft.)

Deformed Shank Nails:

2.5" (8d) for Bow
 3.5" (16d) for S4S lumber
 2.0" (6d) for S4S braces

or

2.5" (8d) for Bow
 4.0" (20d) for full dim. lumber
 2.5" (8d) for full dim. braces

3/8" or 1/2" Rope, Plastic Baler Twine - Length as req'd
 All lumber should be pressure treated for longer life.

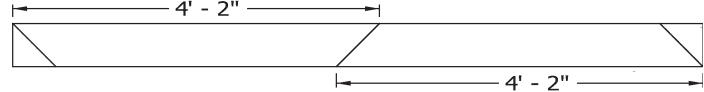

Cutting pattern for 1x6 braces from 8' - 0"
 (or 16'-0") board, all angles 45 deg.

Labor Considerations

The labor for transporting the frames (both empty and filled) and filling in the field for the one group of frames was approximately 11 worker-hours per acre.

The labor for hauling the tobacco and filling the other group of frames at the sod area was approximately 17 worker-hours per acre.

The labor for covering was approximately five additional worker-hours per acre capacity of frames (22 to 23 frames per acre).

Reaching up to shoulder-height to place the tobacco in the cantilever beam is more tiring than conventional loading but may be better than standing on tier rails. Handling each heavy stick only once or twice is certainly a savings of time and energy over the multiple times to load and pass sticks up to the top tiers in a barn.

References

Walton, L.R., J.H. Casada, L.D. Swetnam, M.E. Fiedeldey, and M.J. Bader. 1985. A portable frame cantilever system for burley tobacco. *Transactions of the ASAE* 28(2):568-570.

Educational programs of Kentucky Cooperative Extension serve all people regardless of race, color, age, sex, religion, disability, or national origin. Issued in furtherance of Cooperative Extension work, Acts of May 8 and June 30, 1914, in cooperation with the U.S. Department of Agriculture, M. Scott Smith, Director of Cooperative Extension Service, University of Kentucky College of Agriculture, Lexington, and Kentucky State University, Frankfort. Copyright © 2005 for materials developed by University of Kentucky Cooperative Extension. This publication may be reproduced in portions or its entirety for educational or nonprofit purposes only. Permitted users shall give credit to the author(s) and include this copyright notice. Publications are also available on the World Wide Web at www.ca.uky.edu.