

Research Report

KTC-15-07/SPR11-424-1F

DOI: <http://dx.doi.org/10.13023/KTC.RR.2015.07>

Preventative Maintenance Program For Bridges

Our Mission

We provide services to the transportation community through research, technology transfer and education. We create and participate in partnerships to promote safe and effective transportation systems.

© 2015 University of Kentucky, Kentucky Transportation Center
Information may not be used, reproduced, or republished without our written consent.

Kentucky Transportation Center

176 Oliver H. Raymond Building

Lexington, KY 40506-0281

(859) 257-4513

fax (859) 257-1815

www.ktc.uky.edu

**Research Report
KTC-15-07/SPR11-424-1F**

PREVENTIVE MAINTENANCE PROGRAM FOR BRIDGES

By

Theodore Hopwood II
Program Manager, Research

Jared Fairchild
Research Technician II

Bobby W. Meade
Engineering Technologist

and

Sudhir Palle
Associate Engineer IV, Research

Kentucky Transportation Center
College of Engineering
University of Kentucky
Lexington, Kentucky

In cooperation with
Kentucky Transportation Cabinet
Commonwealth of Kentucky

The contents of this report reflect the views of the authors, who are responsible for the facts and accuracy of the data presented herein. The contents do not necessarily reflect the official views or policies of the University of Kentucky, the Kentucky Transportation Center, the Kentucky Transportation Cabinet, the United States Department of Transportation, or the Federal Highway Administration. This report does not constitute a standard, specification, or regulation. The inclusion of manufacturer names or trade names is for identification purposes and should not be considered an endorsement.

July 2015

1. Report No. KTC-15-07/SPR11-424-1F	2. Government Accession No.	3. Recipient's Catalog No.	
4. Title and Subtitle Preventive Maintenance Program for Bridges		5. Report Date July 2015	
7. Author(s) , Theodore Hopwood II, Jared Fairchild, Bobby W. Meade Hopwood II and Sudhir Palle		6. Performing Organization Code KTC-15-07/SPR11-424-1F	
9. Performing Organization Name and Address Kentucky Transportation Center College of Engineering University of Kentucky Lexington, KY 40506-0043		8. Performing Organization Report KTC-15-07/SPR11-424-1F	
12. Sponsoring Agency Name and Address Kentucky Transportation Cabinet State Office Building Frankfort, KY 40622		10. Work Unit No. (TRAIS)	
		11. Contractor Grant No. KYSPR 11-424	
15. Supplementary Notes Prepared in cooperation with the Kentucky Transportation Cabinet, Federal Highway Administration, and U.S. Department of Transportation. Study Title: Preventive Maintenance Program for Bridges		13. Type of Report and Period Covered Final	
		14. Sponsoring Agency Code	
16. Abstract The Kentucky Transportation Cabinet's (KYTC) bridge inventory is rapidly aging. As such, the Cabinet needs to identify and implement relevant preventative maintenance (PM) actions to extend the useful service lives of those structures. Maintenance actions, costs, and application interval/repair durability information have been obtained for both cyclical and condition-based bridge PM. Additionally, information rehabilitation actions were acquired from a regional DOT survey and from other literature. As part of this study, the Kentucky Transportation Center (KTC) researchers monitored a KYTC bridge washing project to assess its level of effectiveness and to identify potential improvements. Based upon these tasks, recommended guidance was provided to KYTC for use when implementing bridge PM programs. The guidance includes a discussion of critical PM activities, strategies to adopt training and work documents (i.e., special notes) for contract work, and the implementation of work standards/special operating procedures for work performed by KYTC personnel. This report also includes details on the tools and training KYTC district-level personnel will need and outlines a roadmap for conducting pilot programmatic PM work in several districts.			
17. Key Words bridges, cyclical maintenance, condition-based maintenance, preservation, preventive maintenance, rehabilitation, restorative actions		18. Distribution Statement Unlimited with the approval of the Kentucky Transportation Cabinet	
19. Security Classification (report) Unclassified	20. Security Classification (this page) Unclassified	21. No. of Pages 80	22. Price

TABLE OF CONTENTS

List Of Figures	4
List Of Tables	5
Acknowledgements.....	6
Executive Summary	7
1. Introduction.....	11
1.1. Background.....	11
1.2 Project Work Plan.....	13
2. Preventive Maintenance Of Bridges	14
2.1 Introduction.....	14
2.2 Literature Search And Dot Contacts.....	14
2.3 Preventive Maintenance Activities & Costs	14
2.4 Map-21 And Bridge Preservation	22
3. Monitoring Experimental Bridge Cleaning	25
4. Conclusions.....	28
5. Recommendations.....	30
6. References.....	31
7. Tables.....	32
9. Appendix A – Special Notes For Bridge Cleaning.....	53
10. Appendix B – Literature Review	68
11. Appendix C– Michigan Dot Bridge Deck Repair Matrices.....	72

LIST OF FIGURES

Figure 1. Age Distribution of KYTC Bridges from 2013 NBI File.....	44
Figure 2. Total Costs to Maintain Bridges Showing the Effect of Maintenance in Reducing Overall Costs Versus Relying Solely on Replacement (4).....	45
Figure 3. Shows Repair Costs versus Condition Rating for a Large DOT Bridge Inventory (4).	45
Figure 4. Virginia DOT Average Bridge Maintenance or Repair Cost per Square Foot Based Upon Bridge NBI Condition (6).....	46
Figure 5. Trash and Roadway Debris Build-up on an Abutment. Note Corrosion on Bearing	46
Figure 6. Debris Removal at an Abutment Revealing Corrosion of Bearing and Beam End.....	47
Figure 7. Paint Left on the Ground after a Bridge Washing Operation	47
Figure 8. Worker Using a Hand Tool to Clean a Rocker Assembly. Note the Lack of a Safety Harness/Tie Off.....	48
Figure 9. Worker on Ladder Washing Beam Ends	48
Figure 10. Washing a Superstructure and Substructure with Worker Standing on the Pier Cap. Note the Lack of a Safety Harness/Tie Off.	49
Figure 11. Bresle Patches Applied to Vertical and Horizontal Surfaces of KY 453 over P&L Railroad (B00045N).	49
Figure 12. Extracting Initial Water Sample from Bresle Patch to Measure Surface Chloride Contamination Prior to Pressure Washing on KY 453 over P&L Railroad (B00045N).	50
Figure 13. Measuring Conductivity of a Water Sample Using a Portable Conductivity Meter to determine Chloride Content.	50
Figure 14. Conductivity tests location on a beam end after bridge pressure washing.	51
Figure 15. Conversion Coating Applied over Corroded Beam and Greased Bearing.	51
Figure 16. Conversion Coating Applied over Stratified Rust.	52
Figure 17. Sealer Application on Bridge Pier with Lack of Coverage.	52

LIST OF TABLES

Table 1. Preventive Maintenance (Cyclical Activities)	32
Table 2. Preventive Maintenance (Condition-Based Activities).....	34
Table 3. Rehabilitation.....	36
Table 4. Deck Treatments, Unit Costs and Service Lives (KTC 2012).....	37
Table 5. Selected Virginia DOT Costs for Maintenance Activities (February 2011 Through March 2013)	38
Table 6. Recommended Intervals for Some Virginia DOT Cyclical Preventive Maintenance Actions	40
Table 7. Virginia DOT Bridge Preservation Actions Based Upon General Condition Ratings (Ref. 18)..	40
Table 8. Virginia DOT Bridge Preservation Actions Based Upon Bridge Element Condition State Guidance (Ref. 18).....	42
Table 9. Pre- and Post Wash Bresle Test Results	43

ACKNOWLEDGEMENTS

The authors would like to thank David Steele of the Kentucky Transportation Cabinet who served as the Chairperson for this study.

EXECUTIVE SUMMARY

To improve the condition of the United States' (U.S.) aging and deteriorating bridge infrastructure, state departments of transportation (DOTs) have developed innovative programs to extend the service life of bridges. Many of these initiatives have installed preventative maintenance (PM) programs, which emphasize the importance of routine maintenance activities to keep bridge structures in a functional condition. These programs have taken on increased importance given that over 30 percent of existing bridges in the U.S. have exceeded their 50-year design lives. Aging bridges require repairs, rehabilitation or replacement. Nationally, funding remains insufficient to replace bridges on a large scale. Fiscal constraints pose a challenge to transportation professionals charged with mitigating the effects of aging and deteriorating bridges. PM programs offer DOTs with a solution to keep older bridges in service in a safe and cost-effective manner.

Aging bridges frequently deteriorate due to the cumulative effects of physical, chemical, or weather-related damage. The Kentucky Transportation Cabinet (KYTC) will need to address the challenges associated with its aging bridge inventory (Figure 1). According to the 2014 National Bridge Inventory, the median age of KYTC-maintained bridges is 47.1 years. A significant percentage of these (44.3 percent) have been in service for over 50 years. KYTC's 2013 inventory of bridges lists 8,976 structures. This inventory includes 1,829 bridges that are considered functionally obsolete (20.3 percent) and 585 that are classified as structurally deficient (6.5 percent). Over the 2007–2011 period, KYTC replaced 250 bridges – 2.9 percent of its bridge inventory.

To readdress the problem of deteriorating bridges, the Federal Highway Administration (FHWA) and other transportation organizations have developed a coherent, applied framework termed **Bridge Preservation**. Included under the heading of bridge preservation are “actions or strategies that prevent, delay or reduce the deterioration of bridges or bridge elements, restore the function of existing bridges, keep bridges in good condition and extend their life...and may be preventive or condition-driven (9).” A critical aspect of preserving bridges is instituting PM actions.

The objectives of this research study were to:

1. Identify effective bridge PM actions. Here, effective refers to bridge PM actions being used routinely by other DOTs.
2. Determine best management practices (BMPs) from identified bridge PM actions, applied according to structure type.
3. Determine costs (e.g. unit/life-cycle) associated with bridge PM actions/BMPs.
4. Identify the best methods for employing bridge PM actions/BMPs based upon project scope.
5. Determine PM activities/categories to be addressed by a future PM program and identify issues to consider during implementation.

PM activities are typically categorized as: 1) cyclical or 2) condition-based. Cyclical PM activities are used as part of routine bridge maintenance interventions; they are executed at regular intervals (specified by DOTs). Cyclical PM activities do not directly improve the condition of bridge elements or components. Rather, they preserve the existing structural condition, which in turn delays the onset or reduces the magnitude of deterioration. Condition-based PM activities typically employ restorative actions to maintain bridge elements in a state of good repair. The FHWA has prepared a *Bridge Preservation Guide*, which defines two other important bridge actions: 1) rehabilitation (defined as a bridge preservation activity) and 2) replacement (which does not qualify as a bridge preservation activity). The *Bridge Preservation Guide* defines rehabilitation as actions that are taken to restore a

bridge's structural integrity and to correct major defects that undermine its safety.

The research team reviewed available bridge preservation literature and determined that cyclical or condition-based PM plans may consist of a range of activities. In 2011, the Transportation System Preservation Technical Services Program (TSP2) Midwest Bridge Preservation Partnership (MWBPP) conducted surveys with participating state DOTs that asked about the cyclical and condition-based PM activities they used (10). Seven DOTs responded and collectively identified 92 bridge PM activities practiced by their institutions. This included 38 cyclical, 41 condition-based, and 13 rehabilitative activities. Curtis (11) and Hearn (12) identified other bridge activities that fall under the heading of preventive maintenance and rehabilitation. Based on the review of literature and the surveys, Kentucky Transportation Center (KTC) researchers identified 53 cyclical and 53 condition-based PM actions. Actions were categorized based on the type of bridge component – deck/approach/surface items, superstructure, and substructure. In addition, researchers categorized 31 rehabilitation actions that were separate from the 106 PM activities.

The MWBPP conducted a follow-up survey of participating (Midwest) DOTs to collect additional information on 12 cyclical and 15 condition-based PM activities (identified in the first survey). The follow-up asked DOTs to provide data on costs and condition improvements for each PM activity and to provide intervals for the PM activities. This report summarizes the survey results and discusses the structured approaches of the Michigan and Virginia DOTs; specifically, how they implemented PM activities under the umbrella of formal bridge preservation programs. The summary addresses the number of bridges each DOT maintains, commonly used PM activities, PM application criteria, and the cost of individual PM actions.

Chapter 3 outlines a case study on KTC researchers' observations of PM work conducted on 13 bridges in District 1 in 2012. The work consisted of bridge washing, which was performed by an outside contractor. Each bridge washing project included the following actions:

- 1) Bagging and removing large debris
- 2) Power washing all structural members, including:
 - a. All surfaces within 10 feet of any joint, pier, or abutment
 - b. Each abutment, pile, or pier cap
 - c. All bearing devices
 - d. Trusses, both below and 8 feet above the joints; including the splash zones-where noted
 - e. Drainage systems on each side of a structure, joints (top and bottom), and joint troughs, if applicable
- 3) Removing stratified rust
- 4) Applying a lubricant to the bearings
- 5) Applying a concrete sealer to the abutments, piles, and pier caps.

The total award for the bridge washing contract was \$164,440. While most of the work was performed satisfactorily, KTC researchers identified several issues, including:

- 1) Generation of lead paint debris that was not properly cleaned up
- 2) High salt levels in potable wash water, which increased chloride ion levels on bridge steel after it was washed
- 3) Improper surface preparation, cleaning, and sealing in some areas
- 4) The need for full-time, on-the-job inspectors
- 5) The need to train both workers and inspectors properly

An effective PM program must target a significant portion of KYTC's bridge inventory; PM activities must be performed on many structures and, ideally, they should be part of a large-scale bridge preservation initiative. A well-designed PM program should combine proper management at both KYTC's central office and at the district level, along with sufficient funding to perform the necessary work throughout the state. The nation's current highway transportation bill, Moving Ahead for Progress in the 21st Century Act (MAP-21), has specific provisions on how central office management should be administered for work on the expanded National Highway System (NHS). This report highlights salient provisions from the bill and their potential effect on PM activities. Underlined are the requirements for a risk and performance-based asset management plan that targets for bridge conditions, and listed are the actions required to implement the plan under MAP-21 requirements.

Based on the literature review and case study, KTC researchers advanced these recommendations:

1. Identify common PM activities that KYTC Districts currently perform (including cyclical and condition-based).
 - Evaluate the lists of PM actions in this report and determine a priority list of 10 cyclical and 10 condition-based maintenance actions that will constitute the majority of future KYTC bridge PM activities.
2. Conduct field visits with KYTC districts and DOT officials in other states to determine how they carry out maintenance actions. Discussions should focus on worker training, work standards, special notes, approved materials lists, and related safety actions.
3. After identifying PM actions (Recommendation 1), develop special notes for contract work as well as work standards/standard operating procedures that can be applied to each action.
4. Develop training for contractors and KYTC personnel who are responsible for executing/inspecting PM actions. This should be supplemented with safety training that covers all of the hazards encountered while conducting PM actions: work zone safety, working with hazardous materials (lead paint), and fall protection.
5. Develop quality assurance standards and corresponding procedures to ensure that all PM actions – whether performed by contract or state personnel – meet those standards.
6. Develop a systematic framework that assists state personnel in deciding the proper time to perform PM work. This framework should maximize worker efficiency and reduce the amount of time spent on maintenance. Useful strategies include “baselining” bridges (to bring them to an acceptable condition) and bundling projects to reduce expenses. Focus repairs on the root causes of problems rather than on the resulting symptoms. Once frameworks and approaches are developed, codify them on an experimental basis and mandate that district maintenance activities and the costs are documented for specific structures. Create necessary tools to support these tasks and provide baseline data to evaluate whether the program slows bridge deterioration.
7. Conduct a pilot project within one or two KYTC Districts that employs the structured approach described in Recommendation 6. Monitor the trainings of: 1) district level workers and inspectors, and 2) office personnel use of work documentation/tracking tools.
8. Once the proper infrastructure is in place, pilot districts should begin structured PM work. Closely monitor and assess the work of state personnel and contractors. Evaluate the strengths and weaknesses of work documentation (i.e. special notes and work standards/standard operating procedures) and training procedures. Assess both the costs of PM activities and the amount of work conducted over the course of at least one fiscal year. Prepare progress reports on the pilot program and identify needed changes.
9. Implement needed revisions/improvements to any practice. Work with the pilot districts to incorporate the necessary changes. Repeat the program on a pilot basis for a second year and

document its status.

10. If the pilot bridge program succeeds, assemble findings from the pilot districts and collect supporting data from other DOTs. This will give KYTC officials the empirical evidence needed to seek additional state funds for dedicated bridge PM work.
11. Once funding for PM activities reaches a sufficient level, scale up the pilot program to include all of the KYTC Districts.
12. Formalize and implement a KYTC Bridge Preservation Program.

1. INTRODUCTION

1.1. BACKGROUND

The 2013 Federal Highway Administration's (FHWA) national bridge inventory lists approximately 608,000 bridges in the U.S. About 24 percent of these bridges are structurally deficient or functionally obsolete and warrant major repairs or replacement. Nationally, more than 30 percent of existing bridges have surpassed the theoretical 50- year design lives. Many of those do/will require significant maintenance to remain in service. Replacing or repairing all of these bridges would cost in excess of \$100 billion. Currently, there are insufficient funds available for bridge replacement; lacking this money, the nation's bridges will continue to age and deteriorate. This presents a major challenge to state DOTs. DOTs must develop measures to extend the service lives of older bridges that are both safe and cost-effective. This is not just a financial imperative. DOTs confront this challenge in an era when infrastructure renewal funds are shrinking as the costs for materials and labor skyrocket. Rehabilitation is a requirement for good stewardship, the importance of which is heightened during a period when the government and taxpayers scrutinize infrastructure expenditures.

As bridges age, they deteriorate due to the cumulative damage they incur. In a recent article on the 2014 national bridge inventory, KYTC officials stated that corrosion was the primary cause of bridge damage, followed by traffic, age, and other (miscellaneous) factors (1). For KYTC, this is reflected in the percentage of structurally deficient bridges in the inventory (Figure 1). The most important factor contributing to deterioration may be the use of deicing chemical treatments, which produces collateral damage (corrosion) in concrete and steel. With the advent of liquid anti-icing/deicing salt pretreatments, Kentucky bridges now receive much higher salt application rates (in terms of liquid chloride pretreatments) than just 8 years ago. Deicing treatments accelerate bridge deterioration by promoting corrosion of steel reinforcement in concrete, although its full impact has neither been widely recognized nor fully evaluated. Based upon a 2001 corrosion assessment by the National Association of Corrosion Engineers (NACE), the annual cost of bridge corrosion in the U.S. was \$8.3 billion annually (2). In 2013 NACE revised that direct annual cost to \$13.6 billion (3).

The 2013 inventory of KYTC-maintained bridges included 8,976 structures. Of these, 1,829 bridges were functionally obsolete (20.3 percent) and 585 were structurally deficient (6.5 percent). From 2007 to 2011, KYTC replaced 250 bridges – about 2.9 percent of the bridge inventory. The 2014 NBI Inventory places the average age of the 9,002 KYTC-maintained bridges at 47.1 years. Many of these (44.3 percent) have service lives exceeding 50 years. Between 2013 and 2014, the number of KYTC-maintained bridges classified as functionally obsolete dropped to 1,789 bridges (19.9 percent), while the number of structurally deficient bridges fell to 571 (6.3 percent). There are several ways to account for these declines: 1) new construction and/or rehabilitation work improved the condition of bridges, 2) moving bridges into and out of state maintenance inventory, and 3) reclassifying existing bridges after new inspection data were received.

Several states have implemented large-scale expensive bridge replacement programs to address their backlog of projects. Examples of these programs include the Oregon Transportation Investment Act, the Missouri "Safe and Sound" program, the Pennsylvania Department of Transportation public-private bridge replacement program, and the Massachusetts Accelerated Bridge Program. While aggressive reconstruction programs can eliminate many structurally deficient and functionally obsolete bridges, they also place a burden on a state's finances. Those initiatives range in price from about \$700 million–\$3 billion and involve hundreds of bridges. Those programs may not serve as a good model for KYTC, which has eliminated many substandard bridges over the years.

Often, the characteristics of functionally obsolete KYTC bridges match the characteristics of adjoining roadways. As such, they do not place significant operational constraints on motorists. Structural deficiency is the primary concern in addressing substandard bridges (4). While the number of structurally deficient KYTC bridges has gradually fallen in recent years, a lack of new maintenance initiatives, combined with the state's aging inventory, indicates that the number of structurally deficient bridges in Kentucky will eventually increase.

As Figure 4 demonstrates how aggressive maintenance can slow bridge deterioration significantly, allowing available funds to tackle the backlog of projects targeting structurally deficient bridges (5). Currently, it would take just over \$1 billion to replace or repair all of the deficient bridges in Kentucky (6). The effectiveness of PM programs that provide “the right actions at the right time” can be significant. Figures 3 and 4 indicate that it is less expensive to maintain a bridge than to do nothing - until the structure needs major rehabilitation or replacement (7).

In the past, KYTC bridge maintenance work addressed repairs of damaged bridge components (e.g. deck overlays). Painting steel bridges constituted the major PM action undertaken by KYTC. A previous KTC report recommended increasing the use of preventive maintenance to improve the condition of – and extend - the service lives of KYTC’s aging bridges (8). However, KYTC has not systematically adopted more proactive maintenance practices in its programs through the implementation of preventive maintenance.

An annual investment of \$20.5 billion would be necessary to eliminate the nation’s backlog of bridge projects by 2028. Annual funding is currently at \$12.8 billion. To address this situation, the FHWA and various transportation associations have developed a coherent approach termed **bridge preservation** – this includes “actions or strategies that prevent, delay or reduce the deterioration of bridges or bridge elements, restore the function of existing bridges, keep bridges in good condition and extend their life. Bridge preservation actions may be preventive or condition-driven.” This provides a coherent approach to dealing with the issue of aging bridges; one that does not apply only to “fixing broken stuff” or employing a “worst-first” strategy for bridge maintenance. Most importantly, preservation actions allow DOTs to seek cost-effective maintenance options and to pursue problems by addressing root-level causes. This strategy is preferred over correcting problems as they arise on a piecemeal basis – and often in a superficial, symptomatic manner. Aggressively pursuing **bridge preservation** may resolve the nation’s aging/deteriorating bridge infrastructure problem in the most cost-effective manner.

The new focus on **bridge preservation** introduces the transportation sector to new opportunities and challenges. For the past five years, transportation agencies (FHWA and state DOTs) have identified practices and strategies that can underwrite functional bridge preservation programs, and that would be supported by transportation associations (e.g., AASHTO and APWA). The scope of bridge management systems has reached downward from the system level to the project level. Biannual inspections now incorporate element-level evaluations and decision-based ratings. DOTs have increasingly sought to incorporate nondestructive evaluation and structural health monitoring in their decision-making processes. New PM procedures have been evaluated and long lists of potential bridge preservation actions compiled. DOTs have also examined the procedures required to prepare and implement bridge preservation programs.

Preventive maintenance is a fundamental set of activities for any **bridge preservation** program. AASHTO’s Bridge Preservation Expert Task Group defines preventative maintenance as, “a planned strategy of cost-effective treatments to an existing roadway and its appurtenances that preserves the system, retards future deterioration, and maintains or improves the functional condition of the system (without substantially increasing structural capacity)” (9). When used as part of a bridge preservation framework, preventive maintenance offers an economical way to extend the service lives of bridges already in satisfactory condition (bridges rated as “Fair to Good” in the NBI). This report provides information on preventive maintenance, which KYTC officials can use to develop a set of best maintenance practices. These in turn can inform, promote, and guide the creation of programs that will support the KYTC efforts to manage its bridge assets. Some of the accessed documents were reviewed for impacts on preventive maintenance; specifically: the effects upon Federal legislation (MAP-21) and management issues, how Kentucky and national bridge inventory data promote the need for preventative maintenance, and the implications of future needs and deterioration mechanisms on preventative maintenance. This report will primarily focus on PM actions that KYTC should consider. Included will be guidance on when actions are appropriate, along with costs and action intervals (where available).

1.2 PROJECT WORK PLAN

The study objectives were:

1. Identify effective PM actions. Here, effective refers to bridge PM actions being used routinely by other DOTs.
2. Determine best management practices (BMPs) from identified bridge PM actions, sorted by structure type.
3. Determine costs (e.g. unit/life-cycle) associated with bridge PM actions/BMPs.
4. Identify the best methods for employing bridge PM actions/BMPs based upon project scope.
5. Determine PM activities/categories to be addressed by a future PM program and identify issues that must be considered in the implementation.

To achieve those goals, KTC researchers addressed the following tasks:

1. Conducted a literature review to evaluate PM actions/materials.
2. Contacted select DOTs to identify effective bridge PM actions.
3. Grouped sets of effective bridge PM actions (identified in Task 1) into BMPs that can be performed concurrently. In doing this, created specific BMPs that would be employed on bridges based upon their age and/or condition. Determined the proper sequencing of BMPs and desirable timing for their sequential application. Also, identified any durability factors for PM actions that may affect their application frequency.
4. Contacted DOTs to obtain unit/life-cycle costs for specific PM actions. Estimate the unit/life cycle costs for implementing specific BMPs.
5. Determined the best methods for implementing specific PM actions/BMPs (in-house or by contract), including costs based upon project scope (where automation may provide savings). Identified additional training requirements for in-house personnel and for contractor certifications. *Note: As part of this task, KYTC officials requested that KTC researchers monitor an experimental bridge-washing project conducted in Western Kentucky. This work provided significant insights into issues with properly implementing preventive maintenance actions. Most notably, contractor qualifications and activity oversight were flagged (see below).*

2. PREVENTIVE MAINTENANCE OF BRIDGES

2.1 INTRODUCTION

The FHWA *Bridge Preservation Guide* states that PM activities can be: 1) cyclical or 2) condition-based (9). Cyclical PM activities take place at scheduled intervals. Included among cyclical PM activities are washing, sealing deck joints, providing proper drainage, sealing concrete, painting steel, removing channel debris, and protecting against scour and lubricating bearings. Although these activities will not improve the condition of bridge components, they help to preserve a bridge's existing structural state while delaying or reducing deterioration.

Condition-based PM activities are typically restorative, and the purpose is to keep bridge elements in a state of good repair. Activities that fall under this heading include the replacement of failed deck joints, concrete patching, placing of overlays, spot/zone/complete repainting of steel, installation of scour countermeasures, installation of cathodic protection, and chloride extraction/re-sealing of concrete. Reactive maintenance to fix damage caused by vehicle impacts or fires or to mitigate the consequences of other extreme events may also qualify as condition-based PM activities.

The *Guide* defines two other important bridge actions - rehabilitation (defined as a bridge preservation activity) and replacement (not considered a bridge preservation activity). Rehabilitation restores a bridge's structural integrity and corrects major safety defects. Deck replacement, superstructure replacement, and strengthening are typical rehabilitation activities. Other actions may remove structural deficiencies and correct some (but possibly not all) functional obsolescence issues. Bridge replacement can eliminate all existing bridge deficiencies and install a structure compatible with its roadway. Replacement is important when corridor upgrades are implemented, particularly when roadway relocation/realignment necessitates bridge replacement (irrespective of the existing structure's condition).

2.2 LITERATURE SEARCH AND DOT CONTACTS

A directed literature review identified papers, technical articles, reports, and agency guidance documents related to asset management, bridge maintenance, bridge preservation, and preventive maintenance. Relevant information gleaned from the literature will be addressed throughout this report. Appendix A lists the documents consulted by research team members.

KTC researchers contacted officials from state DOTs that have a commitment to bridge preservation via structured PM activities. Researchers collected information from the Michigan DOT and the Virginia DOT, two agencies active in preventive maintenance and bridge preservation. In addition, KTC researchers obtained a spreadsheet from the MWBPP that summarized the preservation/preventive maintenance activities used by DOTs in that region. The Michigan DOT provided several detailed matrices for bridge deck preventive maintenance actions with service lives. KTC also obtained unit costing information for PM activities from MWBPP DOTs and the Virginia DOT. Based on discussions with officials from several DOTs and the FHWA and the literature reviews, researchers concluded that current available life-cycle cost information for the full range of PM activities is limited. Other information was obtained from journals and reports.

2.3 PREVENTIVE MAINTENANCE ACTIVITIES & COSTS

The literature review yielded a wide range of PM activities. TSP2 MWBPP surveyed DOTs on their use of cyclical and condition-based PM activities in 2011 (11). Seven DOTs responded to the survey, identifying 92 PM activities they practiced. This included 38 cyclical maintenance activities, 41 condition-based maintenance

activities (i.e. repairs), and 13 rehabilitation activities. Of these, 32 related to deck/approach/surface activities (28 relating to maintenance), 27 focused on superstructure activities (24 relating to maintenance), 13 were substructure activities (11 relating to maintenance), and 20 were activities termed “other” (16 relating to maintenance).

Another key source of information on maintenance/rehabilitation activities was a report developed for the Colorado Department of Transportation (12). This document summarized element-level actions, the associated costs, and transition probabilities for assessing improvements during implementation. Maintenance and rehabilitation activities from the DOTs of California, Colorado, Delaware, Florida and Louisiana were also reviewed. A paper addressing bridge preservation actions from a national perspective was also consulted (13). The document covered information from the expert personnel from 12 DOTs, and thus identified 94 bridge activities and developed corresponding classifications. Actions were classified based on locations where the activities took place on bridges. Listed below are bridge elements and the number of activities that were applied to them (in parentheses):

- Decks, approach slabs and roadway (35)
- Superstructure (13)
- Substructure (15)
- Culvert (2)
- Painting and coating (7)
- Scour mitigation (5)
- Additional miscellaneous (17).

They were also grouped by action category with number of applicable actions (in parentheses):

- Operations (5)
- Maintenance (50)
- Preservation (15)
- Rehabilitation (17)
- Improvement (8)
- Replacement (2).

Tables 1-3 summarize – according to category – the maintenance and rehabilitation actions derived from these sources. Actions are grouped based on bridge element and the category of maintenance (i.e., cyclical or condition-based). Where possible, KTC researchers relied on maintenance and rehabilitation action descriptions laid out in the MWBPP survey. Additional material on rehabilitation and maintenance actions from the other sources were matched if possible. In some cases researchers used general action descriptions, which made direct comparisons between the various challenging sources. Some activities described in the other two sources were included, however, the author omits those focused on timber bridges. Table 3 lists 31 rehabilitation activities, separating them from condition-based maintenance (Table 2). Tables 1 and 2 include 53 cyclical and 53 condition-based PM activities, respectively; however, these are not exhaustive lists of every potential PM activity that would fall into each category. The listings show that there are many potential PM activities that can be addressed, although some are more commonplace than others. Some activities pertain to specific structure and element types, but some structures may not be present in a DOT bridge inventory in large numbers (e.g. moveable bridges). Other activities, due to the nature, are not widely employed (e.g. fatigue crack mitigation). All of the PM activities listed have been employed/identified by DOTs as being an effective form of preventative maintenance.

The data below highlight key findings from the MWBPP survey. After documenting PM and rehabilitation actions, a follow-up survey inquired about PM costs, action frequencies, service lives, and resulting condition improvements for the activities below. Questions related to condition improvement were framed in terms of how PM activities affected numerical element condition ratings. Data were sought on 12 cyclical PM activities and 15 condition-based PM activities.

Preventive Maintenance (Cyclical Activities)

1. Approach Pavement Relief Joints
2. Clean/Flush Deck
3. Clean/Seal Expansion Joints
4. Coat Concrete Barrier/Deck Fascia
5. Drainage System Cleaning/Repair
6. Minor Concrete Patching & Repair
7. Seal Bridge Deck Cracking (e.g. Crack Chaser)
8. Seal Deck - Aggregate (e.g. Chip Seal)
9. Seal Deck - Liquid (e.g. Star Macro Deck, Pavon In-Deck, Silane)
10. Seal Entire Bridge Deck Cracking (e.g. Flood Coat, Healer Sealer)
11. Seal Joints
12. Slope Paving Repair

Preventative Maintenance (Condition-Based Activities)

1. Approach Slab Overlay
2. Cut Relief Joints in Approach Pavement
3. Deck Fascia/Overhang Repair
4. Deck Joint Repair
5. Deck Joint Replacement
6. Deck Repair - Full Depth
7. Deck Repair - Half Sole (Depth)
8. Epoxy Overlay
9. HMA Overlay (Cap – No Membrane)
10. Leveling/Lifting/Stabilization (e.g. Wedging, Mud Jacking) in Approach Pavement
11. Patching with Concrete
12. Patching with HMA Overlay (No Water Proofing Membrane)
13. Patching with HMA Overlay (With Water Proofing Membrane)
14. Railing Paint
15. Shaving Approach Shoulders

Results from the MWBPP survey also contained data on unit costs for condition-based and cyclical preventive maintenance (where provided). DOTs reported intervals for re-treatments on cyclical PM activities. These data derived life-cycle costs. However, the survey results and literature lacked information on the life-cycle costs for condition-based preventive maintenance. This form of maintenance encompasses minor repairs. Below are results from the survey regarding the cost of various PM actions. In the results, “state forces” refers to personnel directly employed by the state to conduct maintenance activities.

Preventive Maintenance (Cyclical Activities)

1. *Approach Pavement Relief Joint*
 - MI reported \$50.00/LF by contract or state forces with a life cycle cost of \$12.50/LF/year (four-year interval)
 - KS, OH and OK reported \$75.00/LF by contract (and state forces by KS and OK).
2. *Clean/Flush Deck*
 - \$300.00-\$800.00/bridge (2 DOTs) by state forces
 - MI reported \$50.00/hour by state forces
 - IA reported a lump sum of \$12,500/bridge by contract; washing was typically done as needed or at a one-year interval.
3. *Clean/Seal Expansion Joints*
 - IA reported \$70.00/LF (1 DOT) by contract or state forces

- MN reported \$123.00/LF by state forces
 - KS reported \$250.00/man hour
 - WI reported \$150.00/bridge. Work was done as needed or at one-year interval.
4. *Coat Concrete Barrier/Deck Fascia*
 - IA reported \$3.00/LF by contract or state forces
 - MN reported \$3.27 by state forces with a life-cycle cost of \$0.47/LF/year (seven-year interval)
 - MI reported \$12.00/SY by contract or state forces
 - OH reported \$14.10/SY by contract
 - WI reported a cost of \$1.71/SY (five-year interval); this cost is very low and possibly erroneous
 5. *Drainage System Cleaning/Repair*
 - KS reported \$250.00/man hour
 - WI reported \$150.00/each (drain). Drainage system cleaning was typically done as needed or at a one-year interval
 6. *Minor Concrete Patching and Repair*
 - Costs ranged from \$16.67-150.00/SF for 6 DOTs. Concrete patching was performed as needed, although it was listed as a cyclical maintenance item.
 7. *Seal Bridge Deck Cracks (e.g. Crack Chaser)*
 - MI reported \$4.50/LF with a life-cycle cost of \$0.64/LF/year (seven-year interval)
 - MN reported \$3.26/LF with a life-cycle cost of \$0.63/LF/year (five-year interval)
 - OH reported a cost of \$25/SY
 - OK reported a cost of \$7.50/LF
 - WI reported a cost of \$2.50/LF with a life-cycle cost of \$0.50/LF/year (five-year interval)
 8. *Seal Deck –Aggregate (e.g. Chip Seal)*
 - MN reported a cost of \$7.00/SF with a life cycle cost of \$0.35/SF/year (20-year interval).
 9. *Seal Deck-Liquid (e.g. –Star Macro Deck, Pavon In-Deck, Silane)*
 - IL reported \$1.00/SF by contract with a life-cycle cost of \$0.25/SF/year (four-year interval)
 - MI reported \$1.67/SF with a life cycle cost of \$0.33/SF/year (five-year interval)
 - NE reported \$1.00/SF
 - OK reported \$0.56/SF
 - WI reported \$0.02/SF; this cost is low and possibly erroneous (five-year interval)
 10. *Seal Entire Bridge Deck Cracking (e.g. Floodcoat, Healer Sealer)*
 - MI reported \$16.00/SY with a life cycle cost of \$0.89/SY/year (18-year interval)
 - MN reported \$1.44/SY with a life cycle cost of \$0.21 (seven-year interval)
 - OH reported \$10/SY
 - OK reported \$15/SY.
 11. *Seal Joints*
 - KS reported a cost of \$250.00/man hour (as-needed interval)
 - MI reported \$15.00/LF with a life cycle cost of \$3.75/LF/year (four-year interval)
 - MN reported \$3.78/LF with a life cycle cost of \$0.47/LF/year (eight-year interval)
 - NE reported \$80.00/LF
 - OH reported \$250.00/hour (as-needed interval)
 - OK reported \$350.00/LF (as-needed interval)
 - WI reported \$0.65/LF with a life cycle cost of \$0.16/LF/year (four-year interval).
 12. *Slope Paving Repair (All states reporting did this work on an as-needed interval).*
 - IA reported \$4.44/SF; this cost is low and possibly erroneous
 - KS reported \$45.00/SF
 - MI reported \$33.33/SF
 - MN reported \$10.00/SFO
 - OH reported \$45.00/SF

Preventive Maintenance (Condition-Based Activities)

1. *Approach Slab Overlay*
 - MN reported \$5.50/SF with a condition rating improvement from 2.5 to 1.5
 - NE reported \$7.50/SF with a condition rating improvement from 1.5 to 1.0
 - OH reported \$70/CY with a condition rating improvement from 3.0 to 1.0
 - OK reported \$100.00/SY with a condition rating improvement from 3.0 to 1.0
 - SD reported \$100.00/SY with a condition rating improvement from 3.0 to 1.0
 - WI reported \$150/ton with a condition improvement from 3.0 to 1.0
2. *Cut Relief Joints in Approach Pavement*
 - KS reported \$60.00/LF with a condition rating improvement from 2.0 to 1.5
 - MI reported \$50.00/LF with no condition rating improvement (1.5 constant)
 - OK reported \$75.00/LF with a condition rating improvement from 2.0 to 1.0
3. *Deck Fascia/Overhang Repair*
 - KS reported \$150.00/LF with a condition rating improvement of 3.0 to 1.0
 - MI reported \$70.00/SF with a condition rating improvement from 2.0 to 1.5
 - MN reported \$120.00/LF with a condition rating improvement from 2.5 to 1.5
 - NE reported \$250.00/LF with a condition rating improvement from 3.0 to 1.5
 - OH reported \$268.34 with a condition rating improvement from 3.0 to 1.0
4. *Deck Joint Repair*
 - KS reported \$100/LF with a condition rating improvement from 3.0 to 1.0
 - MI reported \$300.00/LF with a condition rating improvement from 3.0 to 2.5
 - MN reported \$280.00/LF with a condition rating improvement from 3.0 to 1.0
 - NE reported \$80.00/LF with a condition rating improvement from 3.0 to 1.5
 - OH reported \$86.82/LF with a condition rating improvement from 3.0 to 1.0
 - SD reported \$12,000/joint with a condition rating improvement from 3.0 to 1.0
 - WI reported \$75/LF with a condition rating improvement from 3.0 to 1.0
5. *Deck Joint Replacement*
 - IA reported \$1,000.00/LF with a condition rating improvement from 2.0 to 1.0
 - KS reported \$200/LF with a condition improvement from 3.0 to 1.0
 - MI reported \$450.00/LF with a condition rating improvement from 3.0 to 1.0
 - MN reported \$437.50/LF with a condition rating improvement from 4.0 to 1.0
 - NE reported \$300.00 with a condition rating improvement from 3.0 to 1.0
 - OH reported \$382.21/LF with a condition rating improvement from 3.0 to 1.0
 - OK reported \$ 450.00 with a condition rating improvement from 3.0 to 1.0
 - SD reported \$19,000/joint with a condition rating improvement from 3.0 to 1.0
 - WI reported \$200.00/LF with a condition rating improvement from 3.0 to 1.0
6. *Deck repair- full depth*
 - IL reported \$600/SF with no condition rating improvement
 - IA reported \$43/SF with a condition rating improvement from 2.0 to 1.0
 - KS reported \$300/SYD with a condition rating improvement from 3.0 to 1.0
 - MI reported \$70/SF with a condition rating improvement from 2.0 to 1.5
 - MN reported \$40/SF with a condition rating improvement from 3.0 to fair
 - NE reported \$47/SF with condition rating improvement from 3.0 to 1.0
 - OH reported \$400/CY with a condition rating improvement from 3.0 to 2.0
 - OK reported \$500/SY with a condition rating improvement from 3.0 to 1.0
 - SD reported \$200/SY with a condition rating improvement from 4.0 to 1.0
 - WI reported \$600/CY with a condition rating improvement from 4.0 to 1.0

7. *Deck repair: Half Sole (Depth)*
 - IL reported \$260/SY no condition rating improvement
 - IA reported \$20/SF with a condition rating improvement from 2.0 to 1.0
 - KS reported \$250/SY with a condition rating improvement from 3.0 to 1.0
 - NM reported \$37.5/SF with a condition rating improvement from 2.5 to 1.5
 - NE reported \$21/SF with a condition rating improvement from 3.0 to 1.0
 - OH reported \$193.4787/SF with condition rating improvement from 3.0 to 2.0
 - OK reported \$300/CY with a condition rating improvement from 3.0 to 1.0
 - SD reported \$175/SY with a condition rating improvement from 3.0 to 1.0
8. *Epoxy Overlay*
 - IL reported \$42/SY with no condition rating improvement
 - IA reported \$45/SY with condition rating improvement from 2.0 to 1.0
 - KS reported \$35/SY with condition rating improvement from 2.0 to 1.0
 - NM reported \$7/SF with constant condition rating improvement of 1.5
 - NE reported \$54/SY with a condition rating improvement from 1.0 to 2.0
 - OH reported \$75/SY with a condition rating improvement from 2.0 to 1.0
 - OK reported \$45/SY with a condition rating improvement from 2.0 to 1.0
 - SD reported \$49/SY with a constant condition rating improvement of 1.0
 - SD reported \$35/SY with a constant condition rating improvement of 1.0
9. *HMA overlay (Cap) (no Membrane)*
 - MI reported \$1.2/SF with a condition rating improvement from 3.0 to 1.0
 - WI reported \$15/SF with a condition rating improvement from 3.0 to 1.0
10. *Leveling/Lifting/Stabilization (e.g. Wedging, mud jacking) in approach Pavement*
 - KS reported \$85/CY with a condition rating improvement from 3.0 to 1.0
 - OH reported \$4.591067/pound with a condition rating improvement from 3.0 to 1.0
 - OK reported \$85 with a condition rating improvement from 3.0 to 1.0
 - WI reported \$70/SY with a condition rating improvement from 3.0 to 1.0
11. *Patching with concrete*
 - IA reported \$60/SF with a constant condition rating improvement of 2.0
 - KS reported \$2500/SY with a condition rating improvement from 3.0 to 1.0
 - MI reported \$33/SF with a condition rating improvement from 2.0 to 1.5
 - NE reported \$24/SF with a condition rating improvement from 2.5 to 1.5
 - OH reported \$55.6982/SF with a condition rating improvement from 3.0 to 1.0
 - OK reported \$300/SY with a condition rating improvement from 3.0 to 1.0
 - SD reported \$75/CF with a condition rating improvement from 3.0 to 1.0
 - WI reported \$500/CY with a condition rating improvement from 3.0 to 2.0
12. *Patching with HMA overlay (No water proofing)*
 - MI reported \$1.2/SF with a condition rating improvement from 3.0 to 1.0
 - OH reported \$131/CY with a no condition rating improvement available
 - WI reported \$15/SF with a condition rating improvement from 4.0 to 3.0
13. *Patching with HMA overlay (With water proofing membrane)*
 - KS reported \$40/SY with a condition rating improvement from 3.0 to 2.0
 - MI reported \$4.5/SF with a condition rating improvement from 3.0 to 1.0
 - OH reported \$23/SY with a condition rating improvement from 3.0 to 1.0
14. *Railing Paint*
 - IA reported \$10/SF with a condition rating improvement from 2.0 to 1.0
 - MI reported \$1.33/SF with a constant condition rating improvement of 1.0
 - OH reported \$1.57/SF with no condition rating improvement
 - SD reported \$12.5 with a condition rating improvement from 4.0 to 1.0

15. *Shave approach Shoulders*

- KS reported \$10/SF with a no condition rating improvement.

KTC researchers obtained only limited information on PM life-cycle cost estimates. This knowledge gap should be addressed by a future large-scale national research study. Random sources of PM data can be useful in determining the cost of activities and the appropriate service intervals. Table 4 contains PM costs and the anticipated service lives for deck treatments, recorded during previous KTC research (14). Other sources of information included in-house data compiled by other DOTs (15).

Preventive Maintenance as Part of a Bridge Preservation Program

Any bridge preservation program developed by KYTC should commit to creating a comprehensive, structured long-term PM program. The guidance laid out in this report is based on bridge preservation programs currently employed by the Michigan DOT and Virginia DOT. These are two of the most well-established programs in the U.S. The following sections contain overviews of these programs.

Michigan DOT

In 1998, the Michigan DOT implemented a strategic program to address the condition of its interstate and state-route bridges. The program plan established bridge condition as a performance measure, set goals for bridge conditions, and developed work categories for bridges. A strategic plan that combined improving deficient bridges with maintaining good bridges was implemented shortly thereafter. It included a balanced program of preventive maintenance, rehabilitation, and replacement. By replacing or rehabilitating deficient bridges and keeping good bridges from deteriorating, the Michigan DOT reduced the number of structurally deficient bridges by more than 50 percent. Currently, The Michigan DOT has about 4,400 bridges with spans greater than 20 ft. that are covered under the strategic plan. An additional 1,100 bridges have spans less than 20 ft.

The Michigan DOT's preventive maintenance program consists of Capital Scheduled Maintenance (cyclical preventive maintenance) and Capital Preventive Maintenance (condition-based preventive maintenance). The Capital Scheduled Maintenance activities include:

- superstructure washing
- vegetation control
- drainage system cleaning/repair
- spot painting
- joint repair/replacement
- concrete sealing
- minor concrete patching and repair
- concrete crack sealing
- approach pavement relief joints
- slope paving repair

The Capital Preventive Maintenance activities include:

- joint replacement
- pin & hanger replacement
- complete painting
- zone painting
- epoxy overlays
- deck patching
- scour countermeasures
- HMA overlay with waterproofing membrane
- HMA cap (no membrane)

The work conducted by in-house Michigan DOT crews included repairs, patching, spot painting, and brush cutting.

Michigan DOT performs preventive maintenance on bridges in good condition (NBI rating ≥ 7). Bridges that are in fair condition are subject to rehabilitation (NBI rating 5, 6). Those in poor condition are assigned to eventual replacement (NBI rating ≤ 4). Replacement encompasses projects that replace decks and superstructures as well as those that replace entire bridges. The Michigan DOT has decision matrices for preventive maintenance, rehabilitation, and replacement. There are also decision matrices that apply to specific bridge components, such as bridge decks (see Appendix C). These decision matrices take into account existing bridge conditions to determine what repair options are available; also they gauge the bridge's anticipated durability and service life after repairs are complete. Currently, 23 percent of the Michigan DOT's bridge budget goes toward preventive maintenance, 31 percent is dedicated to rehabilitation, and 48 percent funds replacement.

Virginia DOT

The Virginia DOT's (VDOT) bridge preservation program addresses both preventive maintenance and rehabilitation. It includes two categories of preventive maintenance: 1) planned preventive (cyclic) maintenance and 2) restorative (condition-based) maintenance. The Virginia DOT manages approximately 13,000 bridges with spans > 20 ft. Virginia DOT recently codified best bridge management practices in its Manual of the Structure and Bridge Division (16).

The VDOT action process for PM activities mirrors the program standards set by the Michigan DOT program for different modes of bridge work. NBI ratings help assess the major bridge elements (General Condition Ratings [GCR]) and they guide VDOT's maintenance actions. The overall bridge GCR is equivalent to the lowest GCR of a major bridge element. VDOT has established the following categories:

Good Structures:	Minimum GCR ≥ 6
Fair Structures:	Minimum GCR = 5
Poor Structures:	Minimum GCR ≤ 4

Indicated below are the performance goals for each condition category:

Good Structures:

- Repair or replace all joint seals in Condition State 2 or 3
- Perform condition-based preventive maintenance annually to 2 percent of all the structures with a minimum GCR of 6
- Perform planned preventive maintenance on structure with a minimum GCR of 7 in accordance with Chapter 32 of the *Manual of the Structure and Bridge Division*

Fair Structures:

- Repair or replace all joint seals in Condition State 2 or 3
- Perform restorative maintenance on 6 percent of all the structures with a minimum GCR of 5

Poor Structures:

For each highway system, no more than the following proportion of bridges can be structurally deficient

- Interstates 3 percent
- Primaries 6 percent
- Secondaries 11 percent

- All 8 percent

VDOT's planned PM activities include:

- Deck cleaning
- Deck sealing
- Thin-bonded overlays
- Removal or replacement of joint seals
- Repairing or patching joint walls
- Superstructure cleaning
- Painting beam ends
- Cleaning or lubricating bearings
- Substructure cleaning
- Culvert cleaning
- Stream bank stabilization
- Debris/vegetation removal

Restorative PM activities include:

- Asphalt overlay/membrane
- Rigid overlay, latex/silica fume overlay
- Deck patching
- Repairs to rails, parapets, curbs, safety walks
- Application of wood preservatives
- Repair/replacement of timber deck boards
- Tighten/replacement of deck fasteners,
- Reconstruction of joints
- Closure of joints
- Installation/repair of relief joints
- Bearing alignment, repair, or replacement
- Painting including, overcoating, recoating, and zone coating
- Superstructure repairs
- Substructure repairs
- Settlement repair
- Culvert repairs
- Repair damaged of headwalls and/or endwalls
- Filling scour holes, placing rip-rap and other scour countermeasures

VDOT provided costs for maintenance activities (Table 5) (17, 18). VDOT has recommended time intervals over which to conduct PM activities (Table 6). Currently, 50 percent of the Virginia DOT bridge budget goes toward preventive maintenance (15 percent for planned preventive maintenance, 25 percent for restorative maintenance, and 10 percent for bridge painting). The remaining 50 percent is allocated for rehabilitation and replacement.

2.4 MAP-21 AND BRIDGE PRESERVATION

To remedy the structural deficiencies present throughout KYTC's bridge inventory, many structures must undergo preventative maintenance. Ideally, preventative maintenance will be a part of an ambitious bridge preservation initiative. Any bridge preservation program requires that appropriate management standards be applied at the central office *and* district levels. Sufficient funding is also necessary to ensure work moves forward statewide. The federal government's current highway bill, MAP-21, includes provisions for how central state

transportation agency offices should administer work on the expanded National Highway System (NHS). MAP-21 streamlines the administrative process, letting state DOTs allocate funds among various state transportation programs. In effect, the law affords DOTs wider latitude when deciding how to spend allocated highway funds – they can determine how assets should be distributed among multiple program areas. However, MAP-21 requires that DOTs establish performance-based or outcome-based programs to justify funding allocations and to set goals for managing assets. One of the key goals of that bill is to *maintain* the U.S. highway infrastructure asset system in a state of good repair (19).

Under MAP-21, the National Highway Performance Program (NHPP) combines the NHS, interstate maintenance, and bridge programs, which under past legislation remained separate. Further, it requires a risk- and performance-based asset management plan for infrastructure and it sets targets for condition and performance. Any bridge on the NHS is eligible to receive funding for a range of activities, including replacement, rehabilitation, or preservation (e.g. PM work). It promotes maintaining bridges in a state of good repair and requires that no more than 10 percent of the deck area on the NHS be structurally deficient. Generally, DOTs are encouraged to establish programmatic agreements between themselves and the FHWA on the use of NHS funding. In response to MAP-21, the FHWA is developing rules to guide this process.

When a state DOT sets a target (i.e., goal) for bridge preservation, it is required to: 1) evaluate the current conditions of their bridge inventories; 2) justify bridge preservation actions in light of those findings; 3) review historic condition and funding trends; and 4) identify the funding levels and resources needed to achieve the desired goals (20). When selecting a preservation method, the condition of a bridge should be assessed so the action taken alleviates structural deficiencies, the condition should be tracked, and the appropriate actions (preventive maintenance, rehabilitation and replacement) should be selected. When deciding on the appropriate action(s), transportation agencies should consult guidance, such as the Bridge Preservation Actions Based Upon General Condition Ratings (Tables 7 and 8) (21). The network of transportation agencies can monitor the bridge inventory over time and determine whether conditions are improving or deteriorating and whether the appropriate adjustments in budgets can be made.

When state DOTs decide to implement a PM program, they should follow a set of measured steps to ensure the program is logically structured and can be applied in an orderly manner. The FHWA *Bridge Preservation Guide* defines a systematic PM program (SPM) as “a planned strategy of cost-effective treatments to existing bridges that are intended to maintain or preserve the structural integrity and functionality of elements and/or components, and retard future deterioration, thus maintaining or extending the useful life of the bridge” (22). SPMs do not require a bridge management system although using one would be helpful. When building an SPM program, state DOTs should integrate the following six attributes:

1. Goals and Objectives
 - Clearly defined goals and objectives for the SPM program
2. Inventory and Condition Assessment
 - Description of the availability of tools and resources needed to conduct bridge inspections and assessments
3. Needs Assessment
 - Documented needs assessment process that outlines how PM needs are identified, prioritized, and programmed
4. Cost Effective PM Activities
 - Ability to demonstrate that the proposed PM activities can cost-effectively extend a bridge’s life
5. Accomplishing the Work
 - Availability of tools and resources needed to accomplish the PM work.
6. Reporting and Evaluation
 - A system that will track, evaluate, and report on the planned and accomplished PM work on an annual and/or as-needed basis.

The statewide implementation of a PM program would need to include these attributes and follow the procedures endorsed by the FHWA, or those proven effective by other state DOTs. If KYTC institutes a PM program it will probably need to secure additional appropriations from the state to cover non-NHS bridges. Having an SPM program in place will provide the data necessary to extend bridge PM funding beyond the National Highway System. Due to the unexpectedly broad scope of effective PM actions, identifying detailed PM actions has been deferred to future research.

3. MONITORING EXPERIMENTAL BRIDGE CLEANING

A task added to this study involved monitoring a KYTC bridge washing project. Bridge washing has been used for years by state DOTs located in the northern portion of the U.S. (e.g., Wisconsin, Michigan, Washington and New York). The scope of these washing operations varies with respect to the bridge components that are washed (most other DOTs wash bridge decks/barrier walls) and the washing pressures used (several use low-pressure, high-volume washing rather than power washing). Bridge washing operations may be combined with other tasks such as cleaning deck joints.

In April 2012, the KYTC put to bid a bridge cleaning project in District 1 (121GR12M075-FE02). The potential contractors were asked to perform a number of tasks:

- Bagging and removing large debris
- Power washing all structural members within 10 feet of any joint, pier or abutment
- Cleaning each abutment/pile/pier cap, and all bearing devices – trusses both below and 8 feet above the joints, including the splash zones – where specified
- Power washing and cleaning drainage systems on each side of a structure, joints (top and bottom), and joint troughs
- Removing stratified rust and applying lubricant to the bearings
- Applying a concrete sealer to the abutments/piles/pier caps

Project work was to focus on 13 bridges in the following counties (the number of bridges in each county is indicated in parentheses):

- Graves County (2)
- Livingston County (3)
- Lyon County (1)
- McCracken County (6)
- Marshall County (1)

Appendix A contains the specific details of this project. KYTC's Engineering Estimate projected a total cost of \$422,240. Nine contractors submitted proposals on this project, with a bid range of \$164,440 to \$925,172.50. The project was awarded to the lowest bidder. What made this project unique was its bundling of several non-washing activities.

KTC researchers monitored the contractor's work at the following sites:

- KY 453 over P&L RR (B00045N)
- KY 453 over 62 (B00043 R&L)
- KY 453 over Barkley Canal (B00020N)
- KY 994 over Bottom Ditch (B00017N)
- US 641 over Julian Carroll Parkway (B00126L)
- KY 131 over East Fork of the Clarks River (B00010N)
- US 60 over Island Creek (B00095N)
- US 45 over Ohio River (B00001N)

At each site, KTC researchers observed the application of concrete sealers and grease. They also collected wash water samples to measure their chloride levels (Bresle) and conductivity.

When bridge joint seals fail, water and roadway debris can infiltrate the open joint and accumulate at the underlying abutments and pier caps. The presence of water and debris promote corrosion by retaining moisture and keeping adjacent steel wet. Corrosion may be exacerbated if deicing salts are applied to bridge surfaces and

leak onto abutments, saturating the debris in contact with the steel. Another source of debris is vagrants who camp under bridges. They often leave significant debris in the form of bedding and food containers.

The early stages of work at each site involved removing excess debris (Figures 5 and 6). After the debris build-up was removed, the conditions of the bearing, seat, and beam end could be readily assessed. Corroded areas of the bearings and beam ends were subsequently treated with greases or a conversion coating to protect against continued corrosion.

KTC researchers observed several problems during and after bridge cleaning operations. During their monitoring, KTC researchers noted that KYTC inspectors were not always present during the contractor's work. Before power washing, the contractor hand-tool cleaned bridge components with metal scrapers, wire brushes, and hammers to remove stratified rust. Researchers noted several instances of paint chips – some possibly containing lead (an inference based on their orange color) – being left on the ground around the bridges following rust removal operations, despite the contract specifying that debris was to be removed from bridge site and properly disposed of (Figure 7). No chemical or metals analyses were performed on the paint chips, however, placing ground cloths around the location of washing/rust removing operations to collect any detached paint chips would be a viable measure for avoiding ground contamination. The fact that the stratified rust was neither completely removed nor coated indicates that inspectors need specific training to determine whether contractors have complied with the expectations laid out in their agreements with the state. During the project KTC observed that the contractor's employees rarely used fall arrest systems, which is required by OSHA (Figure 8). A 3,500 psi pressure washer with a 200 ft. hose was used for power washing. There were no provisions established to check working pressure at the gun – something also required in the contract.

Workers gained access to bridge elements from ladders and by working from the pier caps (Figures 9 and 10). This made it difficult to maintain proper gun alignment and the mandated 6–12" standoff distance of the spray nozzle from the surface. Power washing was not always done in a top-down manner (i.e. starting at the top of a structure and working downward toward its base). Some structures were washed bottom up, which reintroduced contaminated wash water to previously cleaned surfaces.

One issue KTC researchers were particularly interested in was the effectiveness of pressure washing in reducing chloride contamination at beam ends. On several bridges KTC tested surface chloride levels before power washing using the Bresle method as per the SSPC Guide 15 (see 23). Following this guidance, a patch cell (i.e., Bresle patch) was placed on the surface for testing. Patches were applied to vertical and horizontal surfaces of the beam ends, which were located under bridge joints (Figures 11 and 12). A fixed volume of deionized water was inserted into the cell using a syringe and the flexible cell was agitated for a fixed time interval (the cell was agitated by rubbing a finger across its surface). The deionized water dissolved surface salts within the cell. Thereafter, the syringe extracted the solution and KTC researchers used the B173 Horiba Conductivity Meter to measure conductivity (Figure 13). The surface concentration of salts was calculated – from this reading – using the following formula:

$$E = (.5) S \cdot V/A$$

Where:

E = surface concentration of equivalent chloride in $\mu\text{g}/\text{cm}^2$

S = conductivity in $\mu\text{S}/\text{cm}$

V = volume of extract solution in mL (1 mL = 1 cm^3)

A = test area in cm^2 (23)

For power washing operations, the contractor used municipal water sourced at locations near the bridges.

Samples for the wash water were taken and read with a Horiba Meter. The municipal water source tested at 470 $\mu\text{S}/\text{cm}$. The Kentucky Department for Environmental Protection's Division of Water provided researchers with content test values for public drinking water. These data suggested that the potable water used in pressure washing may have chloride levels that would pose issues for washing bridges (24). It is likely the elevated levels of chloride ions in the wash water inadvertently increased the amount of chloride on bridge structures. (Table 9). Indeed, after the areas were power washed, surface chloride samples were taken (Figure 14), and many samples revealed that chloride levels increased after power washing had been completed.

After washing the bridge components, the contractor applied a tannate-based polymer conversion coating, Black-Max™, over the corroded areas of beam ends (Figure 15). In some cases, that coating was applied over stratified rust, which cannot adequately protect the beams from future corrosion (Figure 16). Meanwhile, bearings were coated with a grease by hand and/or with brushes, and a hand pump sprayer was used to coat pier caps with concrete sealer. The application point was located at the top of the pier caps, which resulted in incomplete coverage of the specified three-foot face of the pier caps (Figure 17).

Based on observations of contractor performance, the inattention to small details such as failing to remove paint chips and other loose debris, and washing procedures that increased the chloride levels of bridge surfaces, KTC recommends that KYTC provide, oversee, and fund inspector training for bridge-cleaning operations.

4. CONCLUSIONS

Recent PM cost data (life-cycle costs for cyclical maintenance and first costs for condition-based maintenance) was obtained from state DOTs of the MWBPP, of which KYTC is a member. Several other sources of PM activities were scrutinized to establish a national picture of the breadth of those activities, and to provide insight on activities commonly addressed by most, if not all, DOTs. Although the collected data offered a good overview of DOT PM actions, there remains additional – unexamined – information related to DOT implementation practices that must be studied and evaluated before applying them on a broad scale (25).

The variability of PM costs captured by the MWBPP data stems from agency-specific factors. Some of the variables that influence costs are: 1) whether work is performed in-house by DOT personnel or outsourced via contracts, 2) the availability of local contractors and materials, 3) local economic conditions, and 4) regulatory impacts. The cost ranges *may* serve as initial guidance on the lower or upper bounds of expenses KYTC may incur during PM work. But KYTC costs may also fall outside those ranges. The cost data researchers looked at dates from 2010–2011, so KYTC will need to consider the effects of inflation as well as the impacts of increasing material and labor prices when developing a PM program. These data could be acquired from other DOTs. The Colorado report (11) is the most comprehensive compilation of condition-based PM actions; it outlines attendant costs and condition states for performing them. However, the study is also dated –many costs range back to the early 2000s through to 2009, using a U.S. Army Corps of Engineers construction cost indexing procedure. This report also contains element performance data that may determine lifecycle performance for many maintenance and rehabilitation actions. National initiatives will be needed to develop better data to support structured PM programs – irrespective of whether they are applied specifically to bridge preservation programs.

The information presented in Tables 8 and 9 on evaluating bridge condition can be used to guide the selection of structures for which PM work is a viable option. A forthcoming TRB paper/presentation will provide additional guidance in assessing related main component pairs where structural elements are rated “poor” or “severe” (e.g. deck joints can impact conditions of superstructure elements and repairs to superstructure elements can be constrained by conditions of substructure elements). Performing rigorous condition assessment can inform the scope of PM/rehabilitation/replacement actions on bridges and ensure properly coordinated decision-making regarding bridge actions. A related approach would be to conduct “baseline” maintenance on selected bridges to bring all bridge elements to a “good” rating and to limit subsequent work to cyclical PM activities (hopefully for a decade or more).

With respect to sequencing maintenance actions, KYTC should follow the example of New York’s “deck down” approach. This means that PM actions begin with deck work (for deck girder bridges) before proceeding to superstructure issues, then followed by substructures. In the past, KYTC has scheduled bridge painting operations after the completion of deck work and joint repairs (although some contracts specify that joint work and bridge painting occur at the same time). KYTC continues with this scheduling practice, however, there has been a recent focus on joint elimination – where a bridge structure can support it – and rehabilitating cold joints, which have a tendency to leak and accelerate corrosion. Decision making and the execution of bridge maintenance practices are more complex than those specified in idealized scenarios, which suggests the importance of evaluating bridges contextually. The contingencies impacting a particular structure must be considered when deciding on an appropriate plan of action.

Historically, KYTC has been effective at grouping cyclical PM work (e.g., washing the bridge superstructure, cleaning bearings and piers, doing stratified rust removal, and applying protective materials [greases and/or conversion coatings] to bearings and beam-ends). The cost of the observed project came in well below the Engineering Estimate, however, given the problems with the contractor’s performance, KYTC should consider adding more inspection and oversight to ensure all PM activities are performed effectively. There also remain unanswered questions about the effectiveness of the materials (especially greases and conversion coatings).

Major concerns with contractor safe work practices exist, and there are questions relating to working with lead coatings. Lead paint is going to be disturbed on bridges during these cleaning projects. More stringent work requirements must be employed to avoid violations of state worker safety and environmental pollution regulations. These projects need to be overseen by inspectors knowledgeable in the tasks requested and the inspectors should be assigned solely to those projects during the course of the work.

As the literature review demonstrated, the most effective way to implement PM actions is to integrate them into a holistic and balanced bridge preservation program. KYTC has not yet initiated a pilot PM program, so details of how to implement and design a PM program have yet to be determined. Perhaps such a program would vary by district. This study identified specific PM actions, but did not structure them as originally anticipated. That will be deferred to a future study addressing programmatic preventive maintenance (hopefully under the eventual umbrella of a KYTC bridge preservation program).

The most simplistic (and probably the most ineffective) approach to implementing bridge preventive maintenance would be to provide districts with fixed funding levels based on available monies and then charge them to do the best they could with little or no oversight as to how those funds were utilized. The ideal way to implement preventive maintenance is in the form of a structured program with: 1) fixed goals, 2) a timeline for achieving goal, 3) a rational, need-based budget, 4) a plan for addressing the goals and timelines, 5) well-defined tasks, 6) worker training and 7) a detailed maintenance tracking system to record work performed. All of those tasks would be necessary components of an asset management program that would address the requirements of MAP-21.

5. RECOMMENDATIONS

Based on the literature review and case study, KTC researchers put forward the following recommendations:

1. Identify common PM activities that KYTC Districts currently perform (including cyclical and condition-based).
 - Evaluate the lists of PM actions in this report and determine a priority list of 10 cyclical and 10 condition-based maintenance actions that will constitute the majority of KYTC bridge PM activities in the future.
2. Conduct field visits with KYTC districts and DOT officials in other states to determine how they carry out maintenance actions. Discussions should focus on worker training, work standards, special notes, approved materials lists, and related safety actions.
3. After identifying PM actions (Recommendation 1), develop special notes for contract work as well as work standards/standard operating procedures that can be applied to each action.
4. Develop training for contractors and KYTC personnel responsible for executing/inspecting PM actions. This should be supplemented with safety training that covers all of the hazards that workers may face when they conduct PM actions: work zone safety, working with hazardous materials (lead paint), and fall protection.
5. Create quality assurance standards and corresponding procedures to ensure that all PM actions – whether performed by contract or state personnel – meet those standards.
6. Promote a statewide, systematic framework to assist decision-making on the proper time to perform PM work. This framework should maximize worker efficiency and reduce the amount of time spent on maintenance. Useful strategies include “baselining” bridges (to bring them to an acceptable condition) and bundling projects to reduce expenses. Focus repairs on the root causes of problems rather than resulting symptoms. Once frameworks and approaches are developed, codify them on an experimental basis and mandate that district maintenance activities are tracked along with the costs on specific structures. Create necessary tools to support these tasks. Provide baseline data to evaluate the success of the program toward slowing bridge deterioration.
7. Conduct a pilot project within one or two KYTC Districts that employs the structured approach described in Recommendation 6. Monitor the district-level implementation of worker and inspector training. Also oversee training of office personnel in employing work documentation/tracking tools.
8. Once the proper infrastructure is in place, pilot districts should begin structured PM work. Closely monitor and assess the work of state personnel and contractors. Evaluate the strengths and weaknesses of work documentation (i.e. special notes and work standards/standard operating procedures) and training procedures. Assess the costs of PM activities and the amount of work conducted over the course of at least one fiscal year. Prepare a progress report on the pilot program and identify needed changes.
9. Implement needed revisions/improvements to any practice. Work with the pilot districts to incorporate the necessary changes. Repeat the program on a pilot basis for a second year and document its status.
10. If the pilot bridge program succeeds, assemble findings in the pilot districts and supporting data from other DOTs. This will give KYTC officials the empirical evidence needed to seek additional state funds for dedicated bridge PM work.
11. Once funding for PM activities reaches a sufficient level, scale-up the pilot program to include all of the KYTC Districts.
12. Formalize and implement a KYTC Bridge Preservation Program.

6. REFERENCES

1. Barbaccia, T.G. (2014, November). 2014 Bridge Inventory. *Better Roads*, 16-25.
2. Gerhardus, H., Koch, G.H., Brongers, M.P.H., Thompson, N.G., Virmani, Y.P., & Payer, J.H. (2001, September). Corrosion Cost and Preventive Strategies in the United States. *Federal Highway Administration, Report No. FHWA-RD-01-156*, 24.
3. NACE. (2014). Corrosion Central-Highways and Bridges. Retrieved from <http://www.nace.org/Corrosion-Central/Industries/Highways-and-Bridges/>.
4. Kerr, R. (2006). Structurally Deficient & Functionally Obsolete Bridges. *Presentation to Florida Department of Transportation Maintenance Conference*.
5. McCormick, R. (2002, April 9). Transportation System Preservation – A National Perspective. *FHWA Office of Bridge Technology, Presentation to the Northwest Bridge Maintenance Conference*.
6. ASCE. 2013 Report Card for America’s Infrastructure. Retrieved from <http://www.infrastructurereportcard.org/a/#p/bridges/overview>.
7. Milton, J. (2013, October 7). VDOT Performance Needs and Monetary Needs. Document Provided to T. Hopwood
8. Hopwood, T., Brown, R., & Palle, S. (2004, August). Evaluation of the Service Performance of Bridge Components, Kentucky Transportation Center Research Report 04-24-SR179-98-1F.
9. Federal Highway Administration. (2011, August). Bridge Preservation Guide – Maintaining a State of Good Repair Using Cost Effective Investment Strategies. Publication No. FHWA-HIF-1102, 6.
10. Op. Cit. 6, pp. 7, 8.
11. Spreadsheet Provided by Rebecca Curtis. (2013, March 6). Michigan Department of Transportation.
12. Hearn, G. (2012, May). Deterioration and Cost Information for Bridge Management. *Colorado Department of Transportation, DTD Applied Research and Innovation Branch, Report No. CDOT-2012-4*.
13. Johnson, M.B., & Betkas, B.A. (2013). Defining Bridge Preservation by Action Type. *Journal of the Transportation Research Board*, No. 2360, Maintenance and Preservation, 21-26.
14. Kentucky Transportation Center Deck Treatment Survey. (2012). Unreported.
15. Op. Cit. 9.
16. Virginia Department of Transportation. (2014, September 12). Maintenance and Repair. *Structure and Bridge Division*, Chapter 32.
17. Matteo, A. (2012, March 15). VDOT’S BRIDGE PRESERVATION PROGRAM. *NHI Bridge Innovations Webinar 2012*.
18. Virginia DOT cost data provided by J. Milton. (2014, September 22).
19. Federal Highway Administration Office of Policy and Governmental Affairs. (2012, July 17), Moving Ahead for Progress in the 21st Century Act (MAP-21) - A Summary of Highway Provisions. Retrieved from <http://www.fhwa.dot.gov/MAP21/summaryinfo.cfm>.
20. Ahmad, A. (2013, May 10). MAP-21 Q&A and Roundtable Discussion. *Presentation at the 2013 West Bridge Preservation Partnership*.
21. Op. Cit. 6, p. 25.
22. Op. Cit. 6, pp. 14, 15.
23. SSPC-The Society for Protective Coatings. *SSPC Guide 15 Field Methods for Retrieval and Analysis of Soluble Salts on Steel and Other Nonporous Substrates*, 9.
24. Ronie, J., Drinking Water Quality Coordinator of the Kentucky Department for Environmental Protection Division of Water. (2012, June 28). Electronic transmittal of four years of water quality measurement data to Meade, B. of the Kentucky Transportation Center.
25. Croarkin, M. of the Missouri Department of Transportation. (2013, December 10). Email to Hopwood, T.

7. TABLES

Table 1 Preventive Maintenance (Cyclical Activities)

Bridge Element/Action	Sources of DOT Activities		
	MWBPP (Ref. 8)	Colorado (Ref. 9)	National (Ref. 10)
Deck / Approach / Surface Items			
Clean/Flush Deck			
Clean/Seal Expansion Joints			
Seal Deck - Liquid (e.g., Star Macro Deck, Pavon In-Deck, Silane)			
Seal Deck - Aggregate (e.g., chip seal)			
Seal Bridge Deck Cracking (e.g., Crack Chaser)			
Minor Concrete Patching & Repair			
Repair Bridge Deck Asphalt Concrete Potholes			
Slope Paving Repair			
Mill Top of Back wall or Edge of Deck			
Approach Pavement Relief Joints			
Drainage System Cleaning /Repair			
Repair Concrete Curbs and Gutters			
Coat Concrete Barrier / Deck Fascia			
Seal Entire Bridge Deck Cracking (e.g., Floodcoat, Healer Sealer)			
Seal Joints			
Seal Cracks in Approach Slab			
Superstructure			
Superstructure Washing			
Patch/Repair Superstructure Concrete Spalling			
Epoxy Inject Superstructure Cracks			
Fatigue Crack Mitigation			
Clean/Reset Bearings			
Steel Bearing Lubrication			
Clean and Flush Caps (e.g., Drains/Scuppers)			
Coat Concrete Beams			
Movable Bridge Lubrication, Cleaning			
Waterproof Concrete Beams/Girders			

Table 1. Preventive Maintenance (Cyclical Activities) *Continued*

Bridge Element/Action	Sources of DOT Activities		
	MWBPP (Ref. 8)	Colorado (Ref. 9)	National (Ref. 10)
Substructure			
Patch / Repair Minor Substructure Concrete Spalling			
Epoxy Inject Substructure Cracks			
Seal Joints Along Parapet or Wingwalls			
Coat / Seal Concrete Substructure			
Movable Bridge Counterweight Pit Cleaning			
Clean and Flush Caps			
Clean Bearings			
Other			
Repair Washouts / Erosion			
Vegetation Control			
Channel Clearing			
Install/Replace Bird Netting			
Scour Countermeasures			
Cathodic Protection			
Repair/Replace Utilities & Signs			
Maintain Navigation Protection			
Mechanical/Electrical Cleaning			
Remove Drift			
Bank Stabilization (e.g., gabions, rock blanket)			
Clean Culvert Box Sediment			
Remove Loose Concrete			
Tighten Loose Nuts and Bolts (Anywhere on Bridge)			
Remove Graffiti			
Adjust Mechanical Components on Movable Bridges			
Monitor/Test Mechanical or Electrical Components on Movable Bridges			
Install graffiti Deterrent			
Seal Cracks in Concrete Culvert			
Re-point Concrete Culvert			

Table 2. Preventive Maintenance (Condition-Based Activities)

Bridge Element/Action	Sources of DOT Activities		
	MWBPP (Ref. 8)	Colorado (Ref. 9)	National (Ref. 10)
Deck / Approach / Surface Items			
Epoxy Overlay			
Patching with Concrete			
Patching with HMA Overlay (No Waterproofing Membrane)			
Patching with HMA Overlay (With Waterproofing Membrane)			
HMA Overlay (Cap) (no membrane)			
Deck Joint Repair			
Deck Joint Replacement			
Railing Paint			
Repair Approach Railing			
Repair Bridge Railings (Minor or Isolated Repairs of Bridge Railing Regardless of Material)			
Shave Approach Shoulders			
Approach Slab Overlay			
Deck Fascia/Overhang Repair			
Repair Bridge Sidewalks			
Deck Repair - Half Sole (depth)			
Deck Repair - Full Depth			
Leveling/Lifting/Stabilization (e.g., Wedging, Mud jacking) in Approach Pavement			
Cut Relief Joints in Approach Pavement			
Replace Pavement Marking			
Overlay Approach Slab Micro-Silica or Latex			
Superstructure			
Pin & Hanger Replacement			
Steel Spot Painting			
Steel Zone Painting			
Steel Complete Painting			
Apply Acrylic Coatings to Concrete			

Table 2. Preventive Maintenance (Condition-Based Activities) <i>Continued</i>			
Bridge Element/Action	Sources of DOT Activities		
	MWBPP (Ref. 8)	Colorado (Ref. 9)	National (Ref. 10)
Collision Damage Repair(e.g., Heat Straightening)			
Bearing Replacement			
Epoxy Inject Superstructure Cracks			
Drain/Scupper Repair/Replacement			
Temporary Support			
Structural Repair - Section Loss from corrosion			
Steel Paint- Overcoat			
Steel Paint – Recoat			
Bridge Paint Identification			
Minor Patching of Concrete Beams/Girders			
Paint Bearings			
Substructure			
Leveling/Lifting/Stabilization (e.g., Wedging, Mudjacking)			
Patch/Repair Moderate Substructure Concrete Spalling			
Epoxy Inject Substructure Cracks			
Seal Abutments and Caps			
Structural Repair (e.g., pile replacement)			
Paint Structural Steel			
Maintain Seismic Retrofit (Paint or Repair any Wear Items)			
Maintain Seismic Retrofit Components			
Clean and Paint Substructure Elements			
Other			
Mechanical/Electrical Replacement			
Bank Stabilization (e.g., Gabions, Rock Blanket)			
Mechanical/Electrical Repairs			
Soil Stabilization (e.g., Polyurethane Grout Injection)			
False Decking			
Slope Paving Repair			
Repair Scour Monitoring System			
Install/Replace Bridge ID Marker			

Table 3. Rehabilitation

Bridge Element/Action	Sources of DOT Activities		
	MWBPP (Ref. 8)	Colorado (Ref. 9)	National (Ref. 10)
Deck / Approach / Surface Items			
Railing Replacement Including Upgrading to Current Standards			
Shallow Rigid Concrete Overlay (ex. Latex Modified or Micro-Silica Concrete)			
Deep Rigid Concrete Overlay (ex. Latex Modified or Micro-Silica Concrete)			
Approach Slab Replacement			
Install or Upgrade Median Barrier			
Correct Deck Drainage (Cross Slope, Grade or Drainage Capacity)			
Replace Concrete Filler in Steel Grid Deck			
Rehabilitate Connectors in Steel Grid Deck			
Replace Deteriorated Steel Grid Sections			
Replace Deteriorated Boards in Timber Deck			
Superstructure			
Superstructure Rehabilitation			
Superstructure Replacement			
Bridge Widening			
Beam Repairs (e.g., Bolted, Welded, Heat-Straightening)			
Construct New Catwalks			
Replace Gates on Movable Bridges			
Raise Bridge to Increase Underclearance			
Rehabilitate Bearings (Major/Widespread Work Short of Replacement)			
Replace Diaphragm on Concrete Beams/Girders			
Substructure			
Partial/Full Substructure Replacement			
Substructure Repair (extensive)			
Seismic Retrofit			
Replace Navigation Protection (ex. Repair Damaged/Deteriorated Dolphins and Fenders)			

Table 3. Rehabilitation (Cont.)			
Bridge Element/Action	Sources of DOT Activities		
	MWBPP (Ref. 8)	Colorado (Ref. 9)	National (Ref. 10)
Slip lining (Culvert Type bridges)			
Debris Removal, Mud wall Patching, (Attenuator upgrade)			
Large Culverts (4'-20' Spans) almost similar activities as for listed for bridges			
Small Culverts (<4' Spans) similar activities as for the Large Culverts			
Install Scour Monitoring System			
Re-grade Channel under Bridge			
Construct Drainage Flume for Embankments			
Install Slope Paving			

Table 4. Deck Treatments, Unit Costs and Service Lives (KTC 2012)

Agency	Generic type	Applied Cost	Service Life
Texas	Silane	\$2.86/SY	7 years
Texas	Linseed Oil	\$0.98/SY	3 years
Minnesota	Silane	\$0.45/SY	5 years
Illinois	Siloxane	\$0.40/SF	4 years
Illinois	Siloxane	\$0.30/SF	4 years
Tennessee	Asphaltic Sheet	\$7-\$8/SF	15 years
Tennessee	Epoxy-Aggregate	\$45-\$75/SY	20 years
Michigan	Overlay/Healer Sealer	\$16/SY - \$34/SY	10 years
Michigan	Overlay/Healer Sealer	\$16/SY - \$34/SY	10 years
Michigan	Overlay/Healer Sealer	\$16/SY - \$34/SY	10 years
Michigan	Overlay	\$34/SY	10 years
Michigan	Overlay	\$34/SY	10 years
Michigan	Healer Sealer	\$16/SY	10 years
New York	Silane	\$1.50/SF	5 years
New York	Silane	\$1.50/SF	5 years
Missouri	Linseed Oil	\$0.06/SF state forces	1 year
Missouri	Latex	\$0.11/SF state forces	4 years
Missouri	Petroleum	\$0.14/SY state forces	3-5 years
Missouri	Silane	\$4.00/SF	8-10 year
Missouri	Silane	\$4.10/SF	8-10 year

Table 5. Selected Virginia DOT Costs for Maintenance Activities (February 2011 Through March 2013)

ITEM DESCRIPTION	UNIT	MINIMUM	MAXIMUM	AVERAGE
TRAFFIC BARRIER SERVICE CONC.	LF	\$ 20.00	\$ 94.00	\$ 58.31
DECK DRAINAGE SYSTEM	LS	\$ 11,540.75	\$ 82,000.00	\$ 41,577.25
NAVIGATION LIGHTS	LS	\$ 15,000.00	\$ 134,000.00	\$ 56,591.33
PARAPET, CONCRETE	LF	\$ 90.00	\$ 430.00	\$ 127.33
RAILING, TEXAS T-6	LF	\$ 38.00	\$ 220.00	\$ 58.17
SHOTCRETE, CLASS A	SF	\$ 55.00	\$ 89.00	\$ 65.12
SHOTCRETE, CLASS B	SF	\$ 125.00	\$ 125.00	\$ 125.00
BRIDGE DECK GROOVING	SF	\$ 2.00	\$ 37.76	\$ 4.24
STEEL GRID FLOOR	SF	\$ 88.19	\$ 239.11	\$ 104.95
BEARING PADS REPLACEMENT	EA	\$ 1,100.00	\$ 4,500.00	\$ 2,291.37
BEAM SEAT REPAIR	EA	\$ 2,310.00	\$ 5,049.08	\$ 3,405.63
ANOHOR BOLT REPLACEMENT	EA	\$ 250.00	\$ 1,250.00	\$ 527.24
REMOVAL OF ASPHALT CONCRETE OVERLAY	SY	\$ 5.00	\$ 24.10	\$ 14.43
CONC. CLASS A-4 BRIDGE APPR SLAB	CY	\$ 400.00	\$ 500.00	\$ 407.21
REINF. STEEL BRIDGE APPR. SLAB	LB	\$ 0.96	\$ 3.30	\$ 1.20
TYPE A PATCHING (HES)	SY	\$ 90.00	\$ 90.00	\$ 90.00
TYPE A MILLING (1" DEPTH)	SY	\$ 7.00	\$ 38.82	\$ 1,244.00
TYPE A MILLING (1 1/2" DEPTH)	SY	\$ 9.00	\$ 55.00	\$ 168.62
TYPE B PATCHING (HES)	SY	\$ 270.00	\$ 1,500.10	\$ 408.58
EPOXY-MORTOR PATCHING	GAL	\$ 95.00	\$ 358.10	\$ 156.03
CRACK REPAIRS	LF	\$ 48.00	\$ 65.00	\$ 56.46
GRAVITY FILL POLYMER CRACK SEALING	LF	\$ 80.00	\$ 80.00	\$ 80.00
GRAVITY FILL POLYMER CRACK SEALING	SY	\$ 18.79	\$ 68.00	\$ 19.05
WATERPROOFING	SY	\$ 16.50	\$ 105.00	\$ 21.46
ELASTOMERIC EXP. DAM 0"-2"	LF	\$ 120.00	\$ 120.00	\$ 120.00
PREF. ELAST. JT. SEALER 2"	LF	\$ 35.22	\$ 97.00	\$ 44.11
PREF. ELAST. JT. SEALER 5"	LF	\$ 90.00	\$ 90.00	\$ 90.00
EXPANSION JOINT REMOVAL	LF	\$ 10.00	\$ 450.00	\$ 71.58

**Table 6. Selected Virginia DOT Costs for Maintenance Activities (February 2011 Through March 2013)
continued**

ITEM DESCRIPTION	UNIT	MINIMUM	MAXIMUM	AVERAGE
EXPANSION JOINT RECONSTRUCTION	LF	\$ 135.00	\$ 360.65	\$ 159.75
EXPANSION JOINT RECONSTRUCTION (H ₂ ~5)	LF	\$ 175.00	\$ 250.00	\$ 204.20
CLEAN AND RESEAL EXPANSION JOINT	LF	\$ 25.00	\$ 125.00	\$ 37.77
BACK WALL RECONSTRUCTION	LF	\$ 241.96	\$ 850.00	\$ 626.92
BACK WALL RECONSTRUCTION (HES)	LF	\$ 144.95	\$ 450.00	\$ 257.56
POST REPLACEMENT	EA	\$ 805.00	\$ 805.00	\$ 805.00
JACKING AND BLOCKING	EA	\$ 900.80	\$ 5,000.00	\$ 2,532.43
CONC. SUPERSTR. SURFACE REPAIR	SY	\$ 464.26	\$ 3,600.00	\$ 751.46
LATEX HYDRAULIC CEMENT CONCRETE	SY	\$ 80.00	\$ 90.00	\$ 89.78
SILICA FUME HVDRAULIC CEMENT CONCRETE	SV	\$ 55.00	\$ 74.00	\$ 58.66
EPOXV CONC. OVERLAY	SV	\$ 35.00	\$ 80.00	\$ 38.31
SHEET PILES, STEH	SF	\$ 49.63	\$ 49.63	\$ 49.63
SHOTCRETE, CLASS A	SF	\$ 88.00	\$ 210.00	\$ 125.43
SHOTCRETE, CLASS B	SF	\$ 95.00	\$ 95.00	\$ 95.00
RAILING, BR27C 3	LF	\$ 225.00	\$ 300.00	\$ 227.35
STEEL PILES 10"	LF	\$ 60.00	\$ 60.00	\$ 60.00
STEEL PILE 12"	LF	\$ 85.00	\$ 100.00	\$ 99.37
F.R.P. JACKET (24" SQUARE PILES)	LF	\$ 675.00	\$ 675.00	\$ 675.00
CRACK REPAIRS (PIERS)	LF	\$ 38.00	\$ 200.00	\$ 56.55
CRACK REPAIRS	LF	\$ 38.00	\$ 200.00	\$ 47.44
CONCRETE SUBSTRUCT. SURFACE REPAIR	SY	\$ 210.00	\$ 3,000.00	\$ 887.35
COFFERDAM	EA	\$ 100.00	\$ 30,000.00	\$ 7,601.44
DRY RIPRAP CL. I	TON	\$ 24.00	\$ 175.00	\$ 75.97
GROUTED RIPRAP	TON	\$ 195.00	\$ 195.00	\$ 195.00
EROSION CONTROL	TON	\$ 53.33	\$ 225.63	\$ 55.09
CONCRETE PARAPET	LF	\$ 208.00	\$ 260.00	\$ 233.56
CONCRETE SLAB SLOP~ PROTECTION 4"	SY	\$ 70.00	\$ 245.00	\$ 109.92
CONCRETE S~AB SLOPE PROTECTION 6"	SY	\$ 480.00	\$ 480.00	\$ 480.00
WATERPROOFING	SY	\$ 28.00	\$ 300.00	\$ 43.87

**Table 7. Recommended Intervals for Some Virginia DOT
Cyclical Preventive Maintenance Actions**

Activity	Preferred Cycle (years)
Bridge Cleaning	1
Seats & Beam End Washing	2
Cutting & Removing Vegetation	2
Routine Maintenance of Timber Structures	2
Scheduled Replacement of Compression Seal Joints	10
Scheduled Replacement of Pourable Joints	6
Cleaning & Lubricating Bearing Devices	4
Scheduled Installation of Thin Epoxy Overlay	15
Beam Ends Painting	10
Removing Debris from Culverts	5

**Table 8. Virginia DOT Bridge Preservation Actions
Based Upon General Condition Ratings (Ref. 18)**

Code	Description	Common Preservation Actions
9	EXCELLENT CONDITION	Preventive Maintenance
8	VERY GOOD CONDITION No problems noted.	
7	GOOD CONDITION Some minor problems.	
6	SATISFACTORY CONDITION Structural elements show some minor deterioration.	Preventive Maintenance and/or Repairs
5	FAIR CONDITION All primary structural elements are sound but may have some minor section loss, cracking, spalling or scour.	
4	POOR CONDITION Advanced section loss, deterioration, spalling or scour.	Rehabilitation or Replacement
3	SERIOUS CONDITION Loss of section, deterioration, spalling or scour have seriously affected primary structural components. Local failures are possible. Fatigue cracks in steel or shear cracks in concrete may be present.	
2	CRITICAL CONDITION Advanced deterioration of primary structural elements. Fatigue cracks in steel or shear cracks in concrete may be present or scour may have removed substructure support. Unless closely monitored the bridge may have to be closed until corrective action is taken.	
1	IMMINENT FAILURE CONDITION Major deterioration or section loss present in critical structural components or obvious vertical or horizontal movement affecting structure stability. Bridge is closed to traffic but corrective action may put back in light service.	
0	FAILED CONDITION Out of service - beyond corrective action.	

Table 9. Virginia DOT Bridge Preservation Actions Based Upon Bridge Element Condition State Guidance (Ref. 18)

Condition State	Description	Commonly Employed Feasible Actions
1	Varies depending on element – Good	Preventive Maintenance
2	Varies depending on element – Fair	Preventive Maintenance or Repairs
3	Varies depending on element – Poor	Rehabilitation
4	Varies depending on element - Severe	Rehabilitation or Replacement

Table 10. Pre- and Post Wash Bresle Test Results

Location	Pre-Wash ($\mu\text{S}/\text{cm}$)	Surface Chloride Level ($\mu\text{g}/\text{cm}^2$)	Post-Wash ($\mu\text{S}/\text{cm}$)	Surface Chloride Level ($\mu\text{g}/\text{cm}^2$)
KY 453 over P&L RR	101	12.1	174	20.9
KY 453 over P&L RR	41	4.9	54	6.5
US 641 over Purchase Pkwy	58	7.0	59	7.1
US 641 over Purchase Pkwy	53	6.4	158	19.0
US 641 over Purchase Pkwy	27	3.2	58	7.0
US 641 over Purchase Pkwy	46	5.5	52	6.2
US 131 over East Fork	15	1.8	10	1.2
US 131 over East Fork	13	1.6	6	0.7
US 131 over East Fork	21	2.5	20	2.4
US 131 over East Fork	30	3.6	45	5.4
US 60 over Island Creek	5	0.6	5	0.6
US 60 over Island Creek	4	0.5	5	0.6
US 60 over Island Creek	23	2.8	34	4.1
US 60 over Island Creek	23	2.8	101	12.1
US 60 over Island Creek	11	1.3	63	7.6
US 45 over Ohio River	8	1.0	8	1.0
US 45 over Ohio River	9	1.1	10	1.2

8. FIGURES

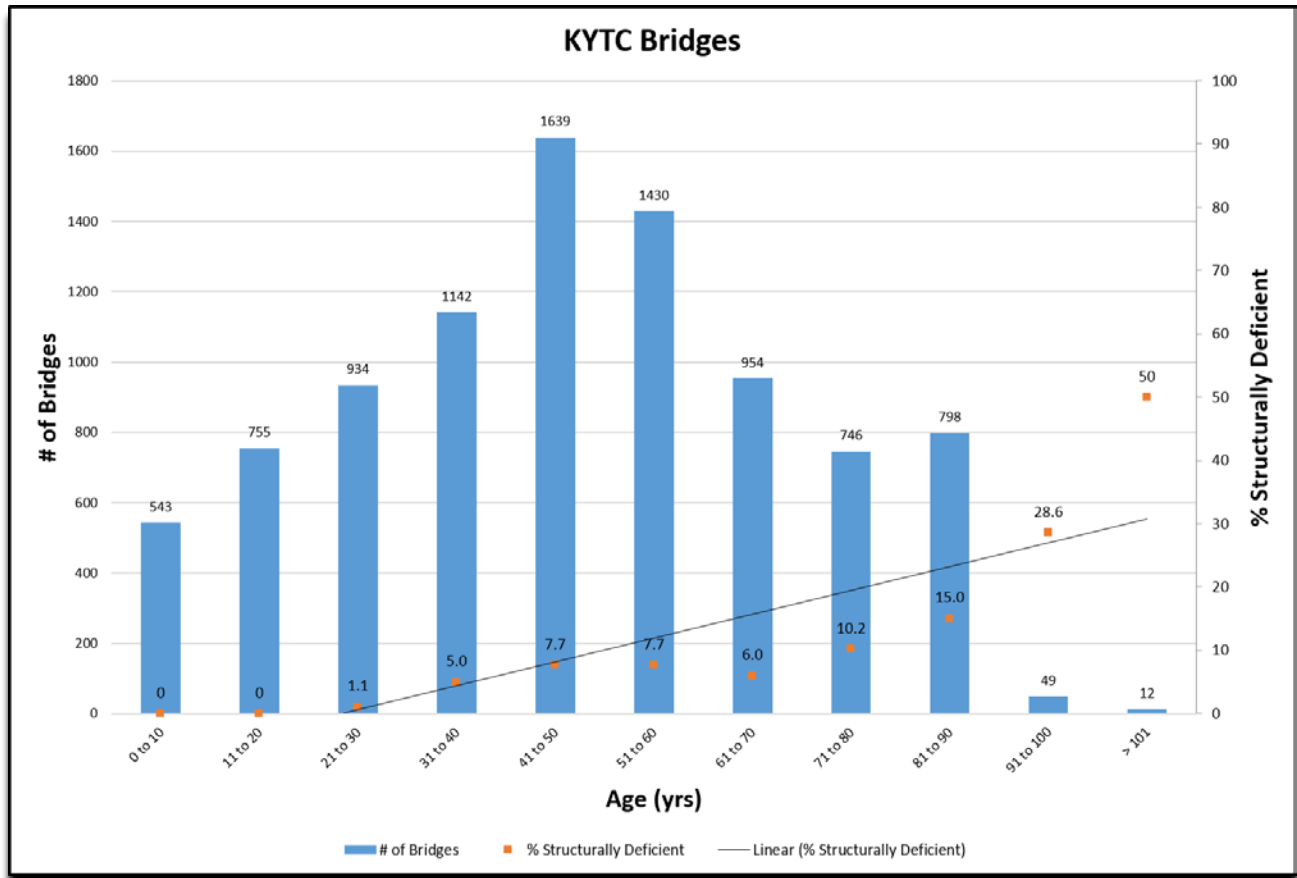

Figure 1- Age Distribution of KYTC Bridges from 2013 NBI File

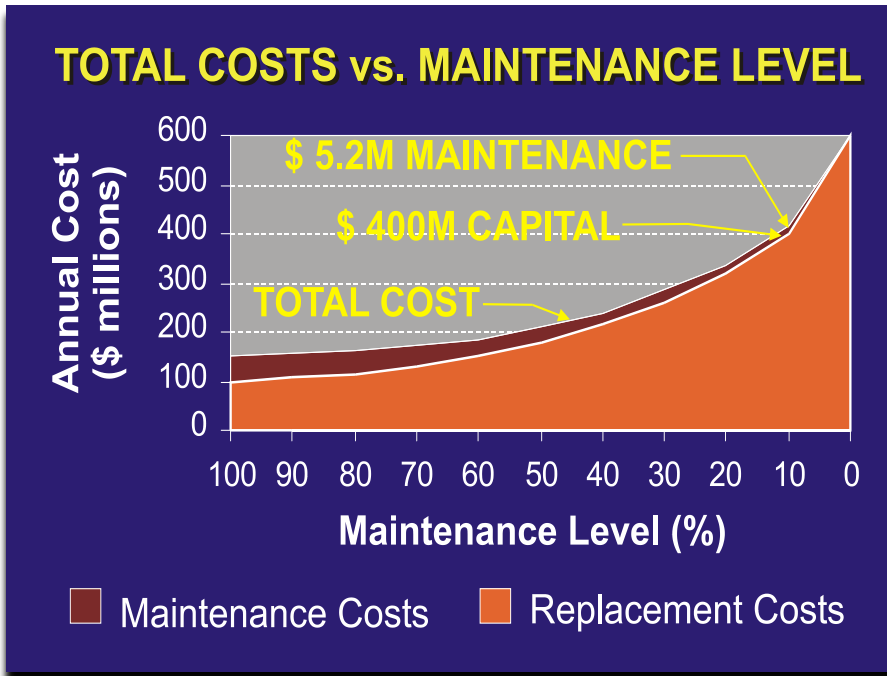

Figure 2. Total Costs to Maintain Bridges Showing the Effect of Maintenance in Reducing Overall Costs Versus Relying Solely on Replacement (4)

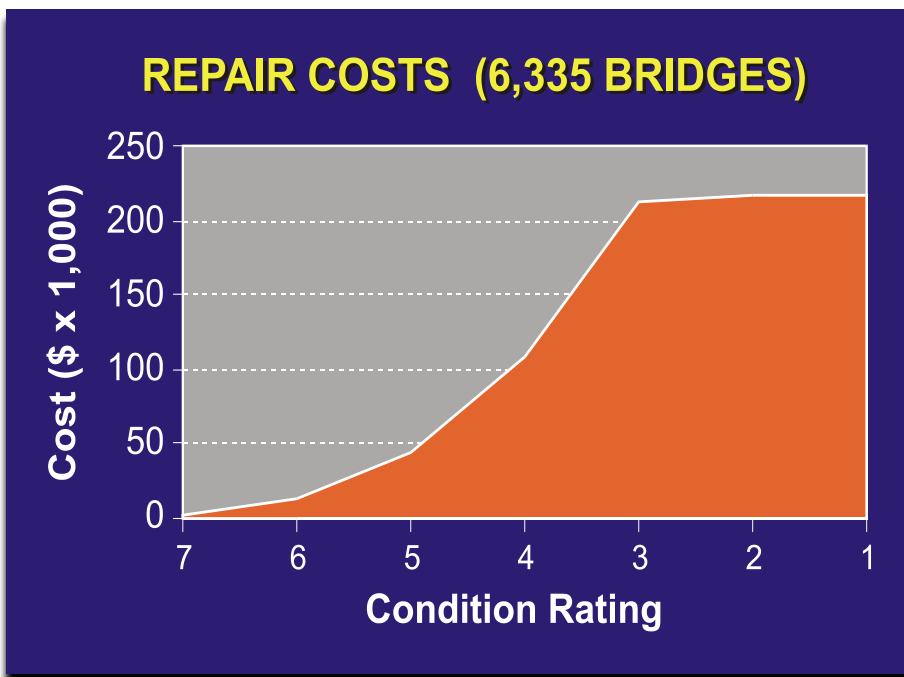

Figure 3. Shows Repair Costs versus Condition Rating for a Large DOT Bridge Inventory (4).

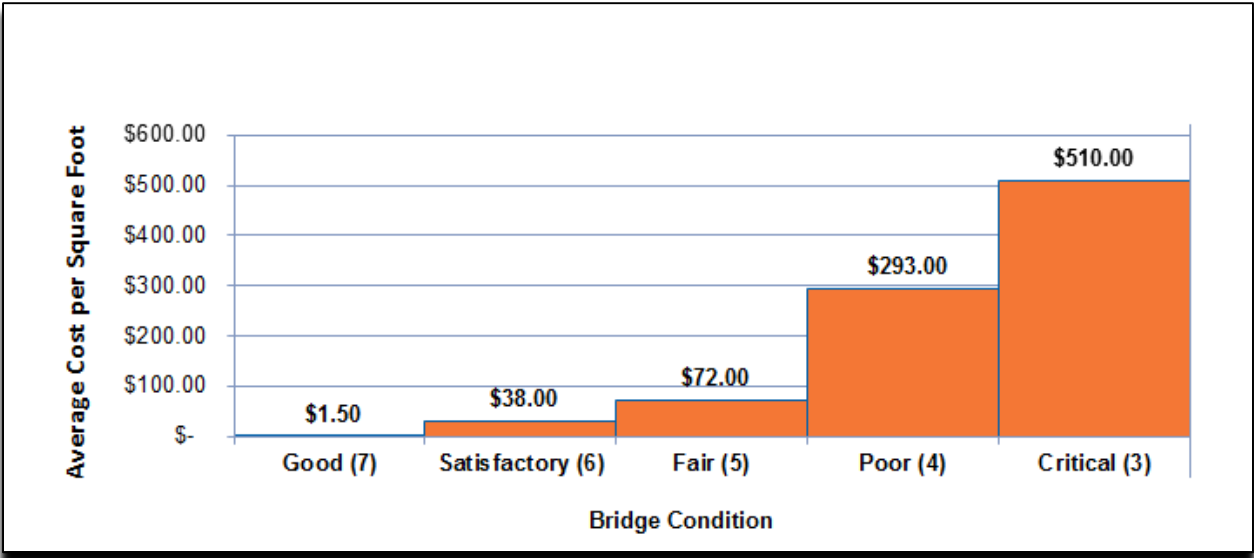

Figure 4. Virginia DOT Average Bridge Maintenance or Repair Cost per Square Foot Based Upon Bridge NBI Condition (6)



Figure 5. Trash and Roadway Debris Build-up on an Abutment. Note Corrosion on Bearing



Figure 6. Debris Removal at an Abutment Revealing Corrosion of Bearing and Beam End



Figure 7. Paint Left on the Ground after a Bridge Washing Operation



Figure 8. Worker Using a Hand Tool to Clean a Rocker Assembly. Note the Lack of a Safety Harness/Tie Off.



Figure 9. Worker on Ladder Washing Beam Ends



Figure 10. Washing a Superstructure and Substructure with Worker Standing on the Pier Cap. Note the Lack of a Safety Harness/Tie Off.



Figure 11. Bresle Patches Applied to Vertical and Horizontal Surfaces of KY 453 over P&L Railroad (B00045N).



Figure 12. Extracting Initial Water Sample from Bresle Patch to Measure Surface Chloride Contamination Prior to Pressure Washing on KY 453 over P&L Railroad (B00045N).



Figure 13. Measuring Conductivity of a Water Sample Using a Portable Conductivity Meter to determine Chloride Content.



Figure 14. Conductivity tests location on a beam end after bridge pressure washing.



Figure 15. Conversion Coating Applied over Corroded Beam and Greased Bearing.



Figure 16. Conversion Coating Applied over Stratified Rust.



Figure 17. Sealer Application on Bridge Pier with Lack of Coverage.

9. APPENDIX A – SPECIAL NOTES FOR BRIDGE CLEANING

eProposal Jan-2009



CALL NO. 411

CONTRACT ID. 122990

GRAVES COUNTY

FED/STATE PROJECT NUMBER 121GR12M075-FE02

DESCRIPTION BRIDGE CLEANING - DISTRICT 1

WORK TYPE BRIDGE CLEANING

PRIMARY COMPLETION DATE 7/31/2012

LETTING DATE: April 20, 2012

Sealed Bids will be received electronically through the Bid Express bidding service until 10:00 AM EASTERN DAYLIGHT TIME April 20, 2012. Bids will be publicly announced at 10:00 AM EASTERN DAYLIGHT TIME.

REQUIRED BID PROPOSAL GUARANTY: Not less than 5% of the total bid.

PART I
SCOPE OF WORK

CONTRACT ID - 122990

ADMINISTRATIVE DISTRICT - 01

PROJECT(S) IDENTIFICATION AND DESCRIPTION:

COUNTY - GRAVES
121GR12M075-FE02

BRIDGE CLEANING - DISTRICT 1

COUNTY - GRAVES PES - MB04200451201
FE02 042 0045 B00212L
US 45 OVER MAYFIELD CREEK GRAVES COUNTY-US 45 (MP 30.712). BRIDGE CLEANING.
GEOGRAPHIC COORDINATES LATITUDE 36°55'48" LONGITUDE 88°40'24"

COUNTY - GRAVES PES - MB04200451202
FE02 042 0045 B00212R
US 45 OVER MAYFIELD CREEK GRAVES COUNTY-US 45 (MP 30.688). BRIDGE CLEANING.
GEOGRAPHIC COORDINATES LATITUDE 36°55'48" LONGITUDE 88°40'23"

COUNTY - LIVINGSTON PES - MB07004531201
FE02 070 0453 B00043L
KY 453 OVER US 62 LIVINGSTON COUNTY-KY 453 (MP 2.994). BRIDGE CLEANING.
GEOGRAPHIC COORDINATES LATITUDE 37°01'25" LONGITUDE 88°15'19"

COUNTY - LIVINGSTON PES - MB07004531202
FE02 070 0453 B00043R
KY 453 OVER US 62 LIVINGSTON COUNTY-KY 453 (MP 2.994). BRIDGE CLEANING.
GEOGRAPHIC COORDINATES LATITUDE 37°01'25" LONGITUDE 88°15'19"

COUNTY - LIVINGSTON PES - MB07004531203
FE02 070 0453 B00045N
KY 453 OVER P&L RAILROAD LIVINGSTON COUNTY-KY 453 (MP 0.418). BRIDGE CLEANING.
GEOGRAPHIC COORDINATES LATITUDE 36°59'44" LONGITUDE 88°13'42"

COUNTY - LYON PES - MB07204531201
FE02 072 0453 B00020N
KY 453 OVER BARKLEY CANAL LYON COUNTY-KY 453 (MP 0.238). BRIDGE CLEANING.
GEOGRAPHIC COORDINATES LATITUDE 36°59'23" LONGITUDE 88°13'15"

COUNTY - MCCrackEN PES - MB07300451201
FE02 073 0045 B00001N
US 45 OVER OHIO RIVER MCCrackEN COUNTY-US 45 (MP 13.430). BRIDGE CLEANING.
GEOGRAPHIC COORDINATES LATITUDE 37°06'54" LONGITUDE 88°37'45"

COUNTY - MCCrackEN PES - MB07300601202
FE02 073 0060 B00094N
US 60 OVER P&L RAILROAD MCCrackEN COUNTY-US 60 (MP 14.871). BRIDGE CLEANING.
GEOGRAPHIC COORDINATES LATITUDE 37°04'06" LONGITUDE 88°36'09"

COUNTY - MCCrackEN PES - MB07300601203
FE02 073 0060 B00095N
US 60 OVER ISLAND CREEK MCCrackEN COUNTY-US 60 (MP 15.626). BRIDGE CLEANING.
GEOGRAPHIC COORDINATES LATITUDE 37°03'37" LONGITUDE 88°35'38"

COUNTY - MCCrackEN PES - MB07300601204
FE02 073 0060 B00128L
US 60 OVER CLARKS RIVER MCCrackEN COUNTY-US 60 (MP 18.622). BRIDGE CLEANING.
GEOGRAPHIC COORDINATES LATITUDE 37°02'36" LONGITUDE 88°32'51"

COUNTY - MCCrackEN PES - MB07301311201
FE02 073 0131 B00010N
KY 131 OVER EAST FORK OF THE CLARKS RIVER MCCrackEN COUNTY-KY 131 (MP 2.029). BRIDGE
CLEANING.
GEOGRAPHIC COORDINATES LATITUDE 36°58'18" LONGITUDE 88°30'54"

COUNTY - MCCrackEN PES - MB07309941201
FE02 073 0994 B00017N
KY 994 OVER BOTTOM DITCH MCCrackEN COUNTY-KY 994 (MP 2.531). BRIDGE CLEANING.
GEOGRAPHIC COORDINATES LATITUDE 36°58'39" LONGITUDE 88°36'59"

CONTRACT ID - 122990 (CONTINUED)

COUNTY - MARSHALL PES - MB07906411201
FE02 079 0641 B00126L
US 641 OVER JULIAN CARROLL PARKWAY MARSHALL COUNTY-US 641 (MP 3.243) . BRIDGE CLEANING.
GEOGRAPHIC COORDINATES LATITUDE 36°50'54" LONGITUDE 88°22'46"

COMPLETION DATE(S) :
COMPLETION DATE - July 31, 2012
APPLIES TO ENTIRE CONTRACT

4 CALENDAR DAYS
APPLIES TO 042B00212L

4 CALENDAR DAYS
APPLIES TO 042B00212R

3 CALENDAR DAYS
APPLIES TO 070B00043L

3 CALENDAR DAYS
APPLIES TO 070B00043R

3 CALENDAR DAYS
APPLIES TO 070B00045N

4 CALENDAR DAYS
APPLIES TO 072B00020N

14 CALENDAR DAYS
APPLIES TO 073B00001N

5 CALENDAR DAYS
APPLIES TO 073B00010N

4 CALENDAR DAYS
APPLIES TO 073B00017N

5 CALENDAR DAYS
APPLIES TO 073B00094N

6 CALENDAR DAYS
APPLIES TO 073B00095N

4 CALENDAR DAYS
APPLIES TO 073B00128L

3 CALENDAR DAYS
APPLIES TO 079B00126L

**SPECIAL NOTE FOR BRIDGE CLEANING
AND PREVENTIVE MAINTENANCE**

- I. DESCRIPTION.** Perform all work in accordance with the Kentucky Transportation Cabinet, Department of Highway's 2008 Standard Specifications for Road and Bridge Construction and applicable Supplemental Specifications, the Standard Drawings, and this Note. Section references are to the Standard Specifications.

This work consists of the following: (1) Furnish all labor, materials, tools, and equipment; (2) Bag and remove large debris; (3) Power wash all structural members within 10 feet of any joint, pier or abutment, each abutment / pile / pier cap, and all bearing devices. If specified, power wash and clean the drainage system on each side of the structure, joints (top and bottom), and joint trough, if applicable; (4) Remove stratified rust and apply lubricant to the bearings; (5) Apply concrete sealer to the abutment / pile / pier cap.

- II. PREPARATION.** If cleaning the drainage system is required, prior to any other cleaning work, confirm that the bridge drainage system is not blocked by un-removable debris by rodding with a sewer rod or similar tool. A blocked drainage system is considered to be one from which debris cannot be removed using the means specified below in Section III below. If the Engineer has been notified, and concurs that the drainage system is blocked prior to performing other cleaning work, then proceed at the direction of the engineer. If the Contractor does not inspect the bridge drainage system and notify the Engineer prior to beginning work, any blocked drains will be considered to be the result of the Contractor's operations, and all clearing and cleaning of the drainage system shall be done as part of the work of this specification.

- III. CLEANING AND PREVENTIVE MAINTENANCE.** Perform the items in SECTION III on each structure as directed in SECTION IV.

A. REMOVAL OF TRASH AND DEBRIS FROM STRUCTURAL STEEL, BEARINGS, PILE/PIER CAPS, DRAINAGE SYSTEM AND JOINTS. All loose trash and debris shall be collected by sweeping, shoveling, vacuuming and other suitable methods. Equipment for collecting trash and other debris from bridge decks shall be determined by the Contractor, subject to the approval of the Engineer, and will normally consist of, but not be limited to, industrial vacuums, brushes, brooms, and shovels. Plastic shovels shall be used when other shovels are damaging coated surfaces. The contractor shall not cause or allow trash and/or debris from the bridge to be deposited into a wetland, stream, other water body, bridge drainage system, or active traffic lanes during the cleaning of the bridge. Debris and trash collected shall be disposed of in a suitable off-site disposal facility.

B. POWER WASHING. The equipment for pressure washing shall be operated at a pressure of 1,000 psi plus or minus 100 psi (900 to 1,100 psi) at the working location and with a minimum flow rate of 3.5 gal/minute provided that these pressures do not damage the paint or other coatings on the bridge or undercut the grout or harm the

masonry plates beneath the bearings. If these pressures and flow rates cause such damage, then the Contractor shall reduce either or both to a level satisfactory to the Engineer. The pressure washer shall be operated at a distance of 6 inches to one foot from the surface. A gauge will be located at the wand to accurately determine pressure.

Structural Steel – Wash all exposed steel located within 10 feet of any joint. If on a truss bridge, the contractor shall be required to clean all truss steel members from the lower chord to 8 feet above the deck elevation in addition to the area noted around each joint.

Drainage System – All debris and foreign material shall be removed including material in the gutter line, grate, drain casting / coupling / funneling system, and drains / scuppers / downspouts. If the drain is blocked prior to cleaning operation and the debris cannot be removed by methods described above, proceed at the direction of the engineer.

Joints – Remove all debris from and wash the top and bottom of each joint. If the entire top of the joint is not accessible due to traffic control restrictions, then clean the available portions and proceed at the direction of the engineer. If the joint has a trough, then wash the trough until all foreign material has been removed.

Bearings – Prior to washing the bearings, remove the stratified / pack rust and loose paint from the bearing surface. After rust removal, provide an SSPC SP-2 cleaning using a wire brush or equivalent method. Collect all removed materials as indicated in section 3A. Wash each bearing until all foreign material and debris has been removed. See Section C for further instruction on bearing cleaning.

Abutment / Pile / Pier Caps – Wash the entire top and the top 3 feet of the sides of the abutment / pile / pier caps (measurement not including concrete pedestals, if present) until all foreign material has been removed. This note will apply only to abutments, pile or pier caps beneath joints.

C. BEARING CLEANING / LUBRICATING. Allow the bearings to dry. Apply lubricant to all exposed surfaces of the bearing in accordance with the manufacturer's recommendations (minimum 1mm thickness). Apply lubricant within 48 hours of completing the washing of the bearing devices. Disassembly of the bearing will not be required. The lubricant used shall be 'Never Seez – Mariner's Choice' produced by Bostik, Inc., 'Mobil Centaur Moly NLGI Grades 1 or 2' produced by Mobil Oil, 'Premalube #1 WG' produced by Certified Labs or approved equivalent.



Before Cleaning and Grease Application



After Cleaning and Grease Application

D. ABUTMENT / PILE / PIER CAP SEALING. After removing debris and washing the top and sides of the abutment / pile / pier cap, apply 'Belzona 5122 Clear Cladding' produced by Belzona International in accordance with the manufacturer's application instructions. Apply the cladding to the area as shown in the diagram below. Due to the exposure to moisture during washing, the abutment / pile / pier caps must allowed a minimum of 24 hours to dry prior to application (inclement weather may cause the need for additional drying time). The sealer must be applied within 72 hours of completing the washing of the pile / pier caps.

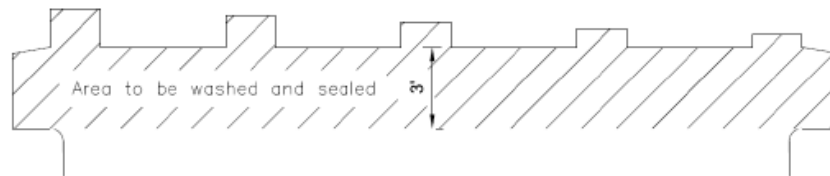

Abutment / Pile / Pier Cap Cleaning and Sealing

E. DECK AND BARRIER WALL SEALING. After power washing the deck and barrier walls, allow the surface to dry for a minimum of 24 hours (inclement weather may cause the need for additional drying time). Apply compressed air to remove any

remaining loose debris from the deck and barrier wall surface. Immediately after applying compressed air, apply 'Belzona 5122 Clear Cladding' produced by Belzona International in accordance with the manufacturer's application instructions. The sealer must be applied within 72 hours of completing the washing of the deck and barrier walls.

- F. COATING RUSTED STEEL MEMBERS.** Remove the stratified rust from the member surface using a wire brush or equivalent method within 4 feet longitudinal of the joint. After removing debris / rust and washing, apply a protective coating to the rusted areas of the structural steel within 4 feet of the joint. The coating should be applied to primary steel members (stringers, floor beams, beams, and girders). The coating used shall be Rhomar Black-Max or approved equivalent. The coating shall be applied in accordance with the manufacturer's application instructions. This note should only be applied to bridges not over a highway.
- G. DAMAGES.** Any damage to the system or structure that occurs during cleaning operations shall be repaired by the Contractor to the satisfaction of the Engineer at no additional expense to the State.
- H. SITE VISIT.** We encourage all contractors to visit each site prior to bidding in order to become familiar with the requirements of this work.

IV. **WORK ITEM ASSIGNMENT.** Complete the work items shown above in Section III B for each bridge as shown in the chart below.

Bridge ID	Cleaning and Powerwashing						Coatings			
	Structural Steel	Drainage System	Joints	Abutments / Pile / Pier Caps	Concrete Deck and Barrier wall	Bearings	Grease Bearings	Abutment / Pile / Pier Cap Concrete Sealing	Deck and Barrier Wall Concrete Sealing	Coating Rusted Steel Members
042B00212L	X	X	X	X	-	X	X	X	-	X
042B00212R	X	X	X	X	-	X	X	X	-	X
070B00043L**	X**	X	X	X**	-	X**	X**	X**	-	-
070B00043R**	X**	X	X	X**	-	X**	X**	X**	-	-
070B00045N**	X**	X	X	X**	-	X**	X**	X**	-	X**
072B00020N	X	X	X	X	-	X	X	X	-	X
073B00001N*	X*	-	-	X	-	X	X	X	-	-
073B00010N	X	X	X	X	-	X	X	X	-	X
073B00017N	X	X	X	X	-	X	X	X	-	X
073B00094N	X	X	X	X	-	X	X	X	-	-
073B00095N	X	X	X	X	-	X	X	X	-	X
073B00128L	X	X	X	X	-	X	X	X	-	X
079B00126L**	X**	X	X	X**	-	X**	X**	X**	-	-

*In the truss sections, wash all truss steel members from lower chord up to 8 feet above deck.
**Only clean, wash, seal, and grease the noted areas at the abutment / end bent locations.

V. **MEASUREMENT.** 'BRIDGE CLEANING AND PREVENTIVE MAINTENANCE'. The Cabinet shall measure this item as a lump sum.

VI. **PAYMENT.** 'BRIDGE CLEANING AND PREVENTIVE MAINTENANCE'. The contract price for this item will be paid as a lump sum. The payment for this bid item at the contract unit price of Lump Sum shall be considered full compensation for complete and accepted work which includes all labor, materials, equipments needed for debris removal, power washing, cleaning and lubricating bearing devices, and cleaning and sealing the pile / pier caps for 'BRIDGE CLEANING AND PREVENTIVE MAINTENANCE'.

KYTC Bridge Cleaning Program
District 1 Group
Standard Drawing

Page 1 of 2

Pier Elevation View (Typical)

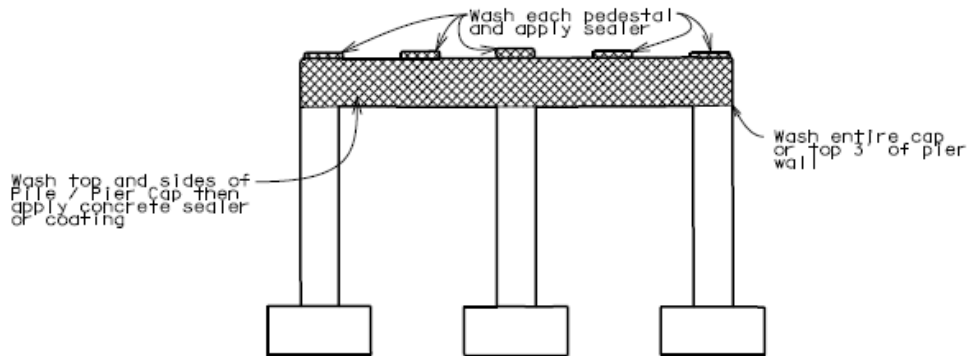

Deck Section View (Typical)

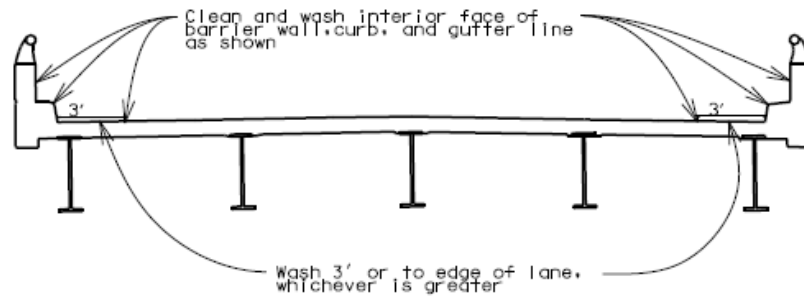

Deck Plan View (Typical)



DETAILS

KYTC Bridge Cleaning Program
District 1 Group
Standard Drawing

Page 2 of 2

Abutment / End Bent Section View (Typical)

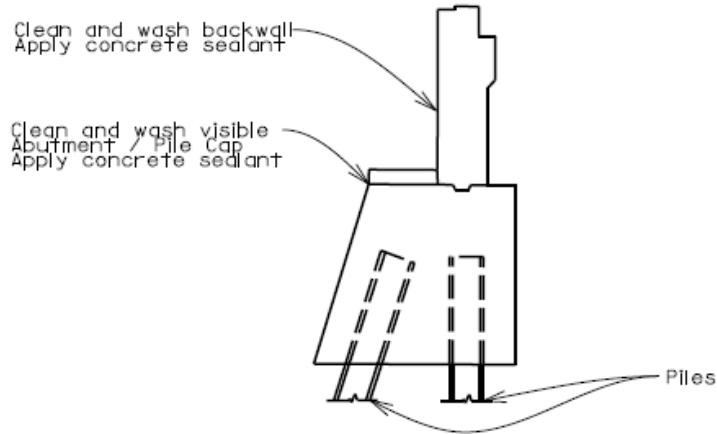

Bearing Grease Detail (Typical)

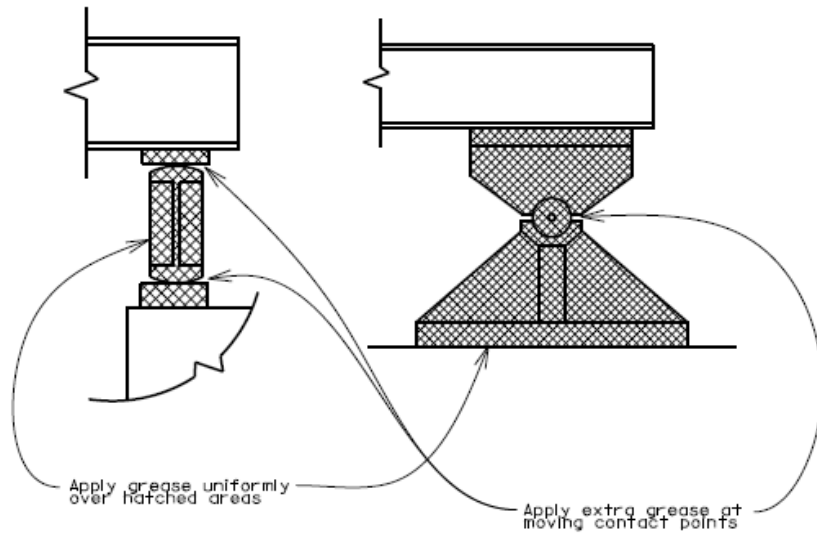

DETAILS

SPECIAL NOTE FOR SUBMITTALS

The Contractor will submit the following written items to the Project Engineer 14 days prior to the Pre-Construction Conference:

1. A Ground Water Protection Plan. The Ground Water Protection Plan will be reviewed by the KYTC Engineer.

All submittals must be approved prior to beginning any work.

SPECIAL NOTE FOR PROTECTING NESTING BIRDS AND BATS

Should an active nest of an osprey or peregrine falcon be located or suspected during bridge work, the KYTC-DEA biologist should be notified. The biologist will notify Kentucky Department of Fish and Wildlife Resources (KDFWR). If an osprey or peregrine falcon is observed diving at bridge personnel or circling the immediate area of bridge work, it can be assumed that a raptor nest is on the bridge. Once contacted, KDFWR can conduct a site visit to confirm the species and nest location. Osprey nests are conspicuous- a few feet wide and made of sticks and vegetation. However, peregrine falcon nests are inconspicuous. Peregrine falcons nest directly on the bridge structure itself, either inside a beam or in a protected area. Bridge workers should be alerted to the possibility of nesting raptors from Mid-February to August 15. Once the nest location is known, bridge workers shall not work within 300 hundred feet of the nest until August 15 or until after the chicks have fledged. KDFWR can monitor the nest and notify the Kentucky Transportation Cabinet once young have fledged.

All nests of other protected migratory birds on bridges should be presumed to be active and occupied between April 15 and August 15. In order to avoid disturbance/destruction of songbird nests (cliff swallow, eastern phoebe, etc.) on bridges the areas within 10 feet laterally of the nest should not be cleaned or washed; pressure washing should start at the 10 feet line and progress away from the nest. Nestlings will fledge within a matter of weeks.

If a roosting bat is encountered, cease cleaning operations in that area, contact the KYTC-DEA biologist and do not disturb the site until they can evaluate the area and make recommendations.

**SPECIAL NOTE FOR PREVENTIVE MAINTENANCE STUDY
BRIDGE CLEANING AND
PREVENTIVE MAINTENANCE**

This project will be part of the Kentucky Transportation Center's (KTC) Preventive Maintenance study. KTC personnel will be allowed access to observe and document the contractor's cleaning process for the length of this project.

The contractor will communicate start and completion dates for each structure to the designated KTC representative noted below. Provide a notice to the KTC representative at least 5 days prior to beginning the project and at least 1 day prior to beginning cleaning at each site.

Primary KTC Point of Contact:

Bob Meade 502-517-1257 bobbymeade@bellsouth.net

Additional Contacts:

Sudhir Palle 859-257-2670 sudhir@engr.uky.edu

Ted Hopwood 859-257-2501 thopwood@engr.uky.edu

**SPECIAL NOTE FOR CONTRACT COMPLETION DATE AND
LIQUIDATED DAMAGES ON BRIDGE REPAIR CONTRACTS**

- I. COMPLETION DATE.** The Contractor has the option of selecting the starting date for this Contract any time after April 20, 2012. Once selected, notify the Department in writing of the date selected at least two weeks prior to beginning work. All work is to be completed in the 2012 construction season by July 31, 2012. An allotted number of Calendar days are assigned to each structure in this contract as shown below.

<u>STRUCTURE</u>	<u>NUMBER OF CALENDAR DAYS</u>
042B00212L	4
042B00212R	4
070B00043L	3
070B00043R	3
070B00045N	3
072B00020N	4
073B00001N	14
073B00010N	5
073B00017N	4
073B00094N	5
073B00095N	6
073B00128L	4
079B00126L	3

Contrary to Section 108.07.02, the Engineer will begin charging calendar days for a structure on the day the Contractor starts work or sets up traffic control on that particular structure.

- II. LIQUIDATED DAMAGES.** Liquidated damages will be assessed the Contractor in accordance with the Transportation Cabinet, Department of Highway's 2008 Standard Specifications for Road and Bridge Construction, Section 108.09, when either the allotted number of calendar days or the July 31, 2012 date is exceeded.

All construction must be completed in accordance with the weather limitations specified in Section 606 and/or Section 601 as applicable. No extension of Contract time will be granted due to inclement weather or temperature limitations that occur due to starting work on the Contract or a structure late in the construction season.

10. APPENDIX B – LITERATURE REVIEW

- Al-eis, K. (2004, January). Evaluation of Roadware 10-Minute Concrete Mender for PCC Bridge Deck Crack Sealing. *Wisconsin Department of Transportation*, Report No. WI-02-04.
- Ahluwalia, H. (2007, August 14). Highway Bridges Gap Analysis. *Report for NACE International, Houston, TX*. Retrieved from http://www.nace.org/nace/images_ndz_story/highwaybridgegapanalysis.pdf.
- Azizinamini, A., Power, E.H., Myers, G.F., & Ozildirim, C.H. (2013). Bridges for Service Life Beyond 100 Years: Innovative Systems, Subsystems and Components. *Florida International University, Project No. SHRP 2 R19A Preliminary Draft Final Report*.
- Barbaccia, T.G. (2013, November). The State of the Nation's Bridges: 2013 Bridge Inventory. *Better Roads*, 7-15.
- Barbaccia, T.G. (2014, November). 2014 Bridge Inventory. *Better Roads*, 16-25.
- Baxter, J.R. (2012, November 19). FHWA Memorandum on National Highway Performance Program (NHPP) Implementation Guidance.
- Better Bridges – 2012 Bridge Inventory. (2012, November). *Better Roads*, 10-19.
- Florida DOT. Bridge Maintenance and Repair Handbook.
- Federal Highway Administration. (2011, August). Bridge Preservation Guide – Maintaining a State of Good Repair Using Cost Effective Investment Strategies. Publication No. FHWA-HIF-1102.
- Byrd, L.G. (1980, January). Deferred Maintenance – Opportune or Optimum Strategy? *Public Works*, 66-70.
- Carney, J. & Stottlemeyer, S. (2010, January). Smooth and Unrestricted Roads and Bridges, Missouri Department of Transportation.
- (1979, May). Consequences of Deferred Maintenance. Transportation Research Board Synthesis 58.
- NACE. (2012, November). Corrosion Control Plan for Bridges. *National Association of Corrosion Engineers*.
- NACE. Corrosion Costs and Preventive Strategies in the United States. *National Association of Corrosion Engineers*. Houston, TX.
- Dinitz, A.M. (2010, June 28-30). Sustainable Polymer Concrete Materials for Bridge and Concrete Rehabilitation, Maintenance, and Preservation. *Presented at the University of Wisconsin Milwaukee Centre for By-Products Utilization, Second International Conference on Sustainable Construction Materials and Technologies*.
- Fontaine, T. (2012, August 10). Highway Funding to Drop under 12-Year Plan; Even Fewer Deficient Bridges Will Be Repaired. *Pittsburgh Tribune Review*.
- Gerhardus, H., Koch, G.H., Brongers, M.P.H., Thompson, N.G., Virmani, Y.P., & Payer, J.H., (2009, September). Corrosion Cost and Preventive Strategies in the United States. *Federal Highway Administration, Report No. FHWA-RD-01-156*.

- Virginia Department of Transportation. (2009, September). Guide Manual for Causes and Repair of Cracks in Bridge Decks.
- Guthrie, W.S. Mitigating Corrosion of Reinforcing Steel in Concrete Bridge Decks: Management Practices in Utah. Brigham Young University.
- Guthrie, W.S., Yuen, L.K., & Ross, L.A. (2009, January 11-15). Design, Installation and Maintenance of Concrete Bridge Deck Joints: State of Practice. *Transportation Research Board, 88th Annual Meeting, Washington, DC*.
- Hatami, A. & Morous, G. (2002). Deterioration Models for Nebraska Bridge Decks. *Journal of the Transportation Research Board*, No. 2313, Structures, 3-11.
- Hearn, G., et al. (2005, April). Bridge Preservation and Maintenance in Europe and South Africa. *Federal Highway Administration, Report No. FHWA-PL-04-007*.
- Hearn, G., Juntenan, D., Ahmad, A. & Johnson, B.V. (2013). Performance Measures for Bridge Preservation. *Journal of the Transportation Research Board*, No. 2360, Maintenance and Preservation, 45-51.
- Hearn, G. (2013, May). Deterioration and Cost Information for Bridge Management, Colorado Department of Transportation, DTD Applied Research and Innovation Branch. *Report No. CDOT-2012-4*.
- Hopwood, T. (2009, February 12). Coatings for Concrete and Steel Structures. *NACE Liberty Bell Corrosion Course*. Horsham, PA.
- Hosking, R.D. (1997, February). Maintenance Over Coating of Existing Paint Systems with Automotive Rustproofing. *Proceedings of the Fifth World Congress on Coating systems for Bridges and Steel Structures – Spanning New Technologies for Compliance*, 56-59. Coatings Institute-University of Missouri-Rolla.
- Johnson, K., Schultz, A.E. French, C., & Reneson, J. (2009, March). Crack and Concrete Deck Sealer Performance. *Department of Civil Engineering, University of Minnesota, Report No. MN/RC 2009-13*.
- Johnson, J.R. (2008, March). Soluble Salts and Specifications – Notes from the Field. *CoatingsPro*, 2-5.
- Johnson, M.B. & Betkas, B.A. (2013). Defining Bridge Preservation by Action Type. *Journal of the Transportation Research Board*, No. 2360, Maintenance and Preservation, 21-26.
- Kerr, R. (2006). Structurally Deficient & Functionally Obsolete Bridges. *Presentation to Florida Department of Transportation Maintenance Conference*.
- Krauss, P.D., Lawler, J.S. & Steiner, K.A. (2009, May). Guidelines for Selection of Bridge Deck Overlays, Sealers and Treatments. *NCHRP 20-07/Task 234*.
- Committee on Appropriations, U.S. Senate. (2013, June 13). Limited Improvement in Bridge Conditions over the Past Decade, but Financial Challenges Remain. *Testimony before the Subcommittee on Transportation, Housing, and Urban Development, and Related Agencies*.
- Lovejoy, S.C. & Myers, B. (2012, July). Effective Use of Structural Health Monitoring for Highway Bridges. *Transportation Research Circular*, No. E-C163, 109-116.
- McCormick, R. (2002, April 9). Transportation System Preservation A National Perspective. *Presentation to the Northwest Bridge Maintenance Conference*.

Meggers, D.A. (1998, January). Crack Sealing and Repair of Older Serviceable Bridges Using Polymer Sealers. *Kansas Department of Transportation, Report No. FHWA-KS-98-4.*

Morse, K.L. (2009, October). Effectiveness of Concrete Deck Sealers and Laminates for Chloride Protection of New and In Situ Reinforced Bridge Decks in Illinois. *Illinois Department of Transportation, Report No. FHWA/IL/PRR-155.*

Morse, K. & Schliff, J. (2012, April). The Deal with the Seal. *Roads and Bridges*, 30-33.

Ohio Department of Transportation. On-Line Bridge Maintenance Manual: Preventive Maintenance Repair Guidelines for Bridges and Culverts. Retrieved from <http://www.dot.state.oh.us/Divisions/Engineering/Structures/bridge%20operations%20and%20maintenance/PreventiveMaintenanceManual/Pages/default.aspx>

Verse Solutions. Quality Management Spotlight: Corrective and Preventive Action.

Radlinska, A., McCarthy, J.R., Yost, J., & Nagel, F.. (2012, February). Coatings and Treatments for Beam Ends. *Villanova University, Report No. FHWA-PA-2012-002-100402.*

Rahim, A., Jansen, D., & Abo-Shadi, N. (2006, May). Concrete Bridge Deck Sealing: An Overview of Research. California Polytechnic State University.

(1998, July). Report Reviews Bridge Maintenance Strategies in the UK. *Journal of Protective Coatings and Linings*, 77-81.

Russell, H.G. (2012). Waterproofing Membranes for Concrete Bridge Decks. *NCHRP Synthesis 425.*

Sharif, M. (2005, May). Protecting New York City's Bridge Assets. *FHWA, Report No. FHWA-HRT-05-005.*

Shirole, A.M. (2006, October 25). ABC's of Life Cycle Cost Analysis. *Statewide Conference on Local Bridges.*

Smith, J.L. & Virmani, Y.P. (2000, August). Materials and Methods for Corrosion Control of Reinforced and Prestressed Concrete Structures in New Construction. *Federal Highway Administration, Report No. FHWA-RD-00-081.*

Sobanjo, J.O. & Thompson, P.D. (2001, July). Development of Agency Maintenance, Repair & Rehabilitation (MR&R) Cost Data for Florida's Bridge Management System. *Florida State University, Contract BB-879.*

Sprinkel, M. (2009, May 21-22). Rapid Repair Materials and Construction. *Presentation to the Rapid Bridge Repair Workshop, Virginia Transportation Research Council.*

Strombeck, S. & Ball, C. (2014, March/April). Options for Extending the Life of Concrete Structures. *The Concrete Repair Bulletin*, 10-28.

(2011) Surface Preparation of Concrete Substrates. *Journal of Protective Coatings and Linings*. A JPCL eBook.

Tabatabai, H., Ghorbanpoor, A., & Pritzl, M.D. (2009, October). Evaluation of Select Methods of Corrosion Prevention, Corrosion Control and Repair of Reinforced Concrete Bridges. Department of Civil Engineering and Mechanics, University of Wisconsin-Milwaukee.

(2010, May). Taming the Bridge Inventory. *Roads&Bridges*, 30-34.

(2013). The Fix We're In For: The State of Our Nation's Bridges 2013. *Transportation for America*. Retrieved from <http://t4america.org/docs/bridgereport2013/2013BridgeReport.pdf>.

Thompson, P.D. (2012, July). Bridge Element Life Expectancy in Florida and Virginia. *Transportation Research Circular, No. E-C163*, 94-107.

Venugopalan, S. (2014, May). Determining Service Life and Life Cycle Costs to Preserve Substructures, Right Action at the Right Time. *Presentation to the National Bridge Preservation Partnership Conference, Orlando Florida*.

Wan, B., Foley, C.M., Ainge, S.W., & Nguyen, C. (2013, March). Procedures, Costs and Effectiveness for Deteriorated Bridge Substructure Repair. *Marquette University, WSDOT Report No. 0092-11-08*.

Wenzlick, J.D. (2007, March). Bridge Deck Concrete Sealers. *Missouri Department of Transportation, Report No. RI 04-051*.

Wilson, B. (2013, May). Some Truth-Bridge Conditions are Improving in the U.S. if only Slightly. *Roads&Bridges*, 22-26.

Washington State Department of Transportation Bridge and Structures Office. (2012, January 11). WSDOT Bridge Painting – 10 Year Plan.

Yanev, B. & Richards, A.C. (2013, April). Designing Bridge Maintenance on the Network and Project Levels. *Structure and Infrastructure Engineering*, 349-363.

Zhang, Y., Novick, D.A., Hadavi, A., & Krizek, R.J. (2003). Whole Life Cycle Cost for Chicago-Type Bascule Bridges. Infrastructure Technology Institute Northwestern University.

11. APPENDIX C– MICHIGAN DOT BRIDGE DECK REPAIR MATRICES

BRIDGE DECK PRESERVATION MATRIX DECKS WITH UNCOATED “BLACK” REBAR USER GUIDELINES

This matrix is a tool for Bridge Engineers to use in the selection of deck repair options when the concrete bridge deck has uncoated “black” rebar. The condition of the deck is usually the driving force, or the key indicator, leading to a structure being considered for preventive maintenance, rehabilitation, or replacement. However, there are times when other issues affecting the bridge may elicit the need for a project and this matrix does not address those situations. Some of these situations are super-structure deterioration, sub-structure deterioration, and functional issues such as under-clearance and/or bridge width. Sometimes it is desirable for an entire corridor to be brought up to a specific condition level as part of an overall strategy. So the user is cautioned to interpret the information from the matrix in the context of each specific case and to use engineering judgment.

The matrix can be used from left to right or from right to left. If you have scoping inspection data with a deck delamination survey, select the row in the left column that matches the percent of surface defects. Then select the row in the second column that matches the percent of underside defects. To the right of this you will find a repair option and the associated changes to the NBI and the expected service life of that repair, or “Fix Life”.

If you are looking for a fix that will last for a given period of time, select a row from the right column that matches the length of service desired and scan to the left to find the repair option. Be advised that the condition of the bridge at the time of the rehabilitation affects the expected service life of the selected repair option. So if the structure is in worse condition than shown on the left side of the matrix, the repair will not last as long. Conversely, if the deck is in better condition than shown on the left, a longer service life could be expected.

This matrix has been constructed based on element deterioration data and the best knowledge of individuals from Construction & Technology, Maintenance, region bridge engineers, bridge design engineers, and FHWA with many years of experience working with bridges. When used in conjunction with the Bridge Safety Inspection Report (BSIR), Pontis element data, and detailed bridge project scoping report, the matrix can be an accurate guide in the majority of situations and will lead to a repair option that is economical and consistent with the Department’s goals.

BRIDGE DECK PRESERVATION MATRIX – Decks with Uncoated “Black” Rebar

DECK CONDITION STATE				REPAIR OPTIONS	POTENTIAL RESULT TO DECK BSIR		ANTICIPATED FIX LIFE
Top Surface		Bottom Surface			Top Surface BSIR #58a	Bottom Surface BSIR #58b	
BSIR #58a	Deficiencies % (a)	BSIR #58b	Deficiencies % (b)				
≥ 5	N/A	N/A	N/A	Hold (c) Seal Cracks/Healer Sealer (d)	No Change	No Change	1 to 4 years
	≤ 5%	> 5	≤ 2%	Epoxy Overlay	8, 9	No Change	10 to 15 years
	≤ 10%	≥ 4	≤ 25%	Deck Patch (e)	Up by 1 pt.	No Change	3 to 10 years
4 or 5	10% to 25%	5 or 6	≤ 10%	Deep Concrete Overlay (h)	8, 9	No Change	25 to 30 years
		4	10% to 25%	Shallow Concrete Overlay (h, i)	8, 9	No Change	20 to 25 years
				HMA Overlay with water- proofing	8, 9	No Change	8 to 10 years
				HMA Cap (g, h, i)	8, 9	No Change	2 to 4 years
2 or 3	> 25%						
<3	>25%	> 5	< 2%	Deep Concrete Overlay (h)	8, 9	No Change	20 to 25 years
		4 or 5	2% to 25%	Shallow Concrete Overlay (h, i)	8, 9	No Change	10 years
				HMA Overlay with water- proofing membrane (f, h, i)	8, 9	No Change	5 to 7 years
				HMA Cap (g, h, i)	8, 9	No Change	1 to 3 years
		2 or 3	>25%	Replacement with Epoxy Coated Rebar (ECR) Deck	9	9	60+ years

- (a) Percent of deck surface area that is spalled, delaminated, or patched with temporary patch material.
- (b) Percent of deck underside area that is spalled, delaminated or map cracked.
- (c) The “Hold” option implies that there is on-going maintenance of filling potholes with cold patch and scaling of incipient spalls.
- (d) Seal cracks when cracks are easily visible and minimal map cracking. Apply healer sealer when crack density is too great to seal individually by hand. Sustains the current condition longer.
- (e) Crack sealing can also be used to seal the perimeter of deck patches.
- (f) Hot Mix Asphalt overlay with waterproofing membrane. Deck patching required prior to placement of waterproofing membrane.
- (g) Hot Mix Asphalt cap without waterproofing membrane for ride quality improvement. Deck should be scheduled for replacement in the 5 year plan.

- (h) If bridge crosses over traveled lanes and the deck contains slag aggregate, do deck replacement.
- (i) When deck bottom surface is rated poor (or worse) and may have loose or delaminated concrete over traveled lanes, an in-depth inspection should be scheduled. Any loose or delaminated concrete should be scaled off and false decking should be placed over traveled lanes where there is potential for additional concrete to become loose.

Bridge Deck Preservation Matrix

June 8, 2011 R

BRIDGE DECK PRESERVATION MATRIX DECKS WITH EPOXY COATED REBAR (ECR) USER GUIDELINES

This matrix is a tool for Bridge Engineers to use in the selection of deck repair options when the concrete bridge deck has epoxy coated rebar (ECR). All ECR decks built since approximately 1980 have epoxy coated steel reinforcement (rebar) placed in the top and bottom rows. As of the date of release of this preservation matrix, there have been few, if any, bridges decks that have reached a poor condition state. For this reason, many of the possible repair options in the matrix are shown in grey. If during a bridge inspection or detailed scope, a bridge deck with epoxy coated rebar is identified as having a deck surface or bottom surface in poor condition, please contact Linda Reed of MDOT's Bridge Operations Section at reedl@michigan.gov.

Deep concrete overlays have been removed from the matrix because the hydro-demolition will destroy the rebar's epoxy coating.

The condition of the deck is usually the driving force, or the key indicator, leading to a structure being considered for preventive maintenance, rehabilitation, or replacement. However, there are times when other issues affecting the bridge may elicit the need for a rehabilitation project and this matrix does not address those situations. Some of these situations are super-structure deterioration, sub-structure deterioration, and functional issues such as under-clearance and/or bridge width. Sometimes it is desirable for an entire corridor to be brought up to a specific condition level as part of an overall strategy. So the user is cautioned to interpret the information from the matrix in the context of each specific case and use engineering judgment.

The matrix can be used from left to right or from right to left. If you have scoping inspection data with a deck delamination survey, select the row in the left column that matches the percent of surface defects. Then select the row in the second column that matches the percent of underside defects. To the right of this you will find a repair option and the associated changes to the NBI and the expected service life of that repair, or "fix life."

If you are looking for a fix that will last for a given period of time, select a row from the right column that matches the length of service desired, and then scan to the left to find the repair option. Be advised that the condition of the bridge at the time of the rehabilitation affects the expected service life of the selected repair option. So if the structure is in worse condition than shown on the left side of the matrix, the repair will not last as long. Conversely, if the deck is in better condition than shown on the left, a longer service life could be expected.

This matrix has been constructed based on element deterioration data and the best knowledge of individuals from Construction & Technology, Maintenance, and Design Support Areas, and FHWA with many years of experience working with bridges. When used in conjunction with the Bridge Safety Inspection Report (BSIR), Pontis Element Data, and Detailed Bridge Project Scoping Report, the matrix can be an accurate guide in the majority of situations and will lead to a repair option that is economical and consistent with the Departments goals.

BRIDGE DECK PRESERVATION MATRIX – DECKS WITH EPOXY COATED REBAR (ECR)

DECK CONDITION STATE				REPAIR OPTIONS	POTENTIAL RESULT TO DECK BSIR		ANTICIPATED FIX LIFE
Top Surface		Bottom Surface			Top Surface BSIR #58a	Bottom Surface BSIR #58b	
BSIR #58a	Deficiencies % (a)	BSIR #58b	Deficiencies % (b)				
≥ 5	N/A	N/A	N/A	Hold (c) Seal Cracks/Healer Sealer (d)	No Change	No Change	1 to 4 years
	≤ 5%	> 5	≤ 2%	Epoxy Overlay	8, 9	No Change	10 to 15 years
	≤ 10%	≥ 4(k)	≤ 25%(k)	Deck Patch (e)	Up by 1 pt.	No Change	3 to 10 years
4(k) or 5	10% to 25%(k)	4(k)	10% to 25%(k)	Shallow Concrete Overlay (h, i)	8, 9	No Change	20 to 25 years
				HMA Overlay with water- proofing membrane (f, h, i)	8, 9	No Change	8 to 10 years
		2 or 3(k)	> 25%(k)	HMA Cap (g, h, i)	8, 9	No Change	2 to 4 years
≤ 3(k)	>25%(k)	4(k) or 5	2% to 25%(k)	Shallow Concrete Overlay (h, i)	8, 9	No Change	10 years
				HMA Overlay with water- proofing membrane (f, h, i)	8, 9	No Change	5 to 7 years
		2 or 3(k)	>25%(k)	HMA Cap (g, h, i)	8, 9	No Change	1 to 3 years
				Replacement with Epoxy Coated Rebar (ECR) Deck	9	9	60+ years

(a) Percent of deck surface area that is spalled, delaminated, or patched with temporary patch material.

(b) Percent of deck underside area that is spalled, delaminated or map cracked.

(c) The “Hold” option implies that there is on-going maintenance of filling potholes with cold patch and scaling of incipient spalls.

(d) Seal cracks when cracks are easily visible and minimal map cracking. Apply healer sealer when crack density is too great to seal individually by hand. Sustains the current condition longer.

(e) Crack sealing can also be used to seal the perimeter of deck patches.

(f) Hot Mix Asphalt overlay with waterproofing membrane. Deck patching required prior to placement of waterproofing membrane.

(g) Hot Mix Asphalt cap without waterproofing membrane for ride quality improvement. Deck should be scheduled for replacement in the 5 year plan.

(h) If bridge crosses over traveled lanes and the deck contains slag aggregate, do deck replacement.

- (i) When deck bottom surface is rated poor (or worse) and may have loose or delaminated concrete over traveled lanes, an in-depth inspection should be scheduled. Any loose or delaminated concrete should be scaled off and false decking should be placed over traveled lanes where there is potential for additional concrete to become loose.
- (k) Contact C&T's Bridge Operations section if a deck with epoxy coated rebar in poor condition is identified.**

Bridge Deck Preservation Matrix

June 8, 201 Rev.

BRIDGE DECK PRESERVATION MATRIX DECKS WITH EPOXY COATED REBAR (ECR) USER GUIDELINES

This matrix is a tool for Bridge Engineers to use in the selection of deck repair options when the concrete bridge deck has epoxy coated rebar (ECR). All ECR decks built since approximately 1980 have epoxy coated steel reinforcement (rebar) placed in the top and bottom rows. As of the date of release of this preservation matrix, there have been few, if any, bridges decks that have reached a poor condition state. For this reason, many of the possible repair options in the matrix are shown in grey. If during a bridge inspection or detailed scope, a bridge deck with epoxy coated rebar is identified as having a deck surface or bottom surface in poor condition, please contact Linda Reed of MDOT's Bridge Operations Section at reedl@michigan.gov.

Deep concrete overlays have been removed from the matrix because the hydro-demolition will destroy the rebar's epoxy coating.

The condition of the deck is usually the driving force, or the key indicator, leading to a structure being considered for preventive maintenance, rehabilitation, or replacement. However, there are times when other issues affecting the bridge may elicit the need for a rehabilitation project and this matrix does not address those situations. Some of these situations are super-structure deterioration, sub-structure deterioration, and functional issues such as under-clearance and/or bridge width. Sometimes it is desirable for an entire corridor to be brought up to a specific condition level as part of an overall strategy. So the user is cautioned to interpret the information from the matrix in the context of each specific case and use engineering judgment.

The matrix can be used from left to right or from right to left. If you have scoping inspection data with a deck delamination survey, select the row in the left column that matches the percent of surface defects. Then select the row in the second column that matches the percent of underside defects. To the right of this you will find a repair option and the associated changes to the NBI and the expected service life of that repair, or "fix life."

If you are looking for a fix that will last for a given period of time, select a row from the right column that matches the length of service desired and scan to the left to find the repair option. Be advised that the condition of the bridge at the time of the rehabilitation affects the expected service life of the selected repair option. So if the structure is in worse condition than shown on the left side of the matrix, the repair will not last as long. Conversely, if the deck is in better condition than shown on the left, a longer service life could be expected.

This matrix has been constructed based on element deterioration data and the best knowledge of individuals from Construction & Technology, Maintenance, and Design Support Areas, and FHWA with many years of experience working with bridges. When used in conjunction with the Bridge Safety Inspection Report (BSIR), Pontis Element Data, and Detailed Bridge Project Scoping Report, the matrix can be an accurate guide in the majority of situations and will lead to a repair option that is economical and consistent with the Departments goals.