



University of Kentucky
UKnowledge

Theses and Dissertations--Biosystems and
Agricultural Engineering

Biosystems and Agricultural Engineering

2016

RECIRCULATING CALCIUM HYDROXIDE SOLUTION: A PRACTICAL CHOICE FOR ON-FARM HIGH SOLIDS LIGNOCELLULOSE PRETREATMENT

William S. Sympson Jr.

University of Kentucky, william.sympson@uky.edu

Digital Object Identifier: <http://dx.doi.org/10.13023/ETD.2016.295>

[Right click to open a feedback form in a new tab to let us know how this document benefits you.](#)

Recommended Citation

Sympson, William S. Jr., "RECIRCULATING CALCIUM HYDROXIDE SOLUTION: A PRACTICAL CHOICE FOR ON-FARM HIGH SOLIDS LIGNOCELLULOSE PRETREATMENT" (2016). *Theses and Dissertations--Biosystems and Agricultural Engineering*. 43.
https://uknowledge.uky.edu/bae_etds/43

This Master's Thesis is brought to you for free and open access by the Biosystems and Agricultural Engineering at UKnowledge. It has been accepted for inclusion in Theses and Dissertations--Biosystems and Agricultural Engineering by an authorized administrator of UKnowledge. For more information, please contact UKnowledge@lsv.uky.edu.

STUDENT AGREEMENT:

I represent that my thesis or dissertation and abstract are my original work. Proper attribution has been given to all outside sources. I understand that I am solely responsible for obtaining any needed copyright permissions. I have obtained needed written permission statement(s) from the owner(s) of each third-party copyrighted matter to be included in my work, allowing electronic distribution (if such use is not permitted by the fair use doctrine) which will be submitted to UKnowledge as Additional File.

I hereby grant to The University of Kentucky and its agents the irrevocable, non-exclusive, and royalty-free license to archive and make accessible my work in whole or in part in all forms of media, now or hereafter known. I agree that the document mentioned above may be made available immediately for worldwide access unless an embargo applies.

I retain all other ownership rights to the copyright of my work. I also retain the right to use in future works (such as articles or books) all or part of my work. I understand that I am free to register the copyright to my work.

REVIEW, APPROVAL AND ACCEPTANCE

The document mentioned above has been reviewed and accepted by the student's advisor, on behalf of the advisory committee, and by the Director of Graduate Studies (DGS), on behalf of the program; we verify that this is the final, approved version of the student's thesis including all changes required by the advisory committee. The undersigned agree to abide by the statements above.

William S. Sympson Jr., Student

Dr. Sue Nokes, Major Professor

Dr. Donald G. Colliver, Director of Graduate Studies

RECIRCULATING CALCIUM HYDROXIDE SOLUTION: A PRACTICAL CHOICE FOR ON-FARM
HIGH SOLIDS LIGNOCELLULOSE PRETREATMENT

THESIS

A thesis submitted in partial fulfillment of the requirements
for the degree of Master of Science in Biosystems and Agricultural
Engineering in the College of Engineering at the University of Kentucky

By

William S. Simpson Jr.

Lexington, Kentucky

Director: Dr. Sue Nokes, Professor and Chair, Biosystems & Agricultural Engineering
Department

Lexington, Kentucky

2016

Copyright © William S. Simpson Jr. 2016

ABSTRACT OF THESIS

RECIRCULATING CALCIUM HYDROXIDE SOLUTION: A PRACTICAL CHOICE FOR ON-FARM HIGH SOLIDS LIGNOCELLULOSE PRETREATMENT

Pretreatment is a necessary step in the utilization of lignocellulosic biomass for biochemical conversion to higher value products. There are multiple chemical choices for industrial settings, however on-farm choices are constrained to near ambient conditions with minimal specialized equipment, training, and limited waste disposal. Calcium hydroxide (lime) is suitable for on-farm use. This work presents the novel idea of pretreating biomass by recirculating a filtered, saturated lime solution in an up-flow, high solids (14-16% w/w) configuration at ambient conditions. In this system, lime solids were efficiently consumed, post-pretreatment washing of substrate did not significantly improve glucose yields, and energy and resources were conserved. Pretreatment effectiveness was assessed by glucose yield comparisons for both switchgrass and corn stover. Using mean glucose yields from 5mm corn stover, lime pretreatment required 350kgs of dry stover to produce 100kgs glucose at a chemical cost of \$8.67 while NaOH required 300kgs at a cost of \$22.38. The recirculation concept was used to enzymatically hydrolyze pretreated substrate in-situ with an initial solids content of 14-16% (w/w). The bulk in-situ hydrolysis produced mean glucose yields ~70% greater than an NREL hydrolysis modified to 16% (w/w) solids and reached ~77% of the yield of an NREL hydrolysis at 2.7% (w/w) solids.

KEYWORDS: *Calcium Hydroxide*, lime, lignocellulose, pretreatment, high solids, bulk hydrolysis.

William S. Sympson Jr.

June 23, 2016

RECIRCULATING CALCIUM HYDROXIDE SOLUTION: A PRACTICAL CHOICE FOR ON-FARM
HIGH SOLIDS LIGNOCELLULOSE PRETREATMENT

By

William S. Sympson Jr.

Dr. Sue Nokes

Director of Thesis

Dr. Donald G. Colliver

Director of Graduate Studies

June 23, 2016

ACKNOWLEDGEMENTS

I firmly believe that our interactions with others, resulting in both positive and negative influences, are the reason any of us are able to achieve our goals. I have a long list of influential people in my life, that without their contribution, I would not be writing this acknowledgement. To those unnamed herein, know that I value and appreciate your influences on my life.

To my major advisor, Dr. Sue Nokes, for the opportunity and guidance, without which I would not have reached this milestone.

To my committee members, Dr. Bert Lynn and Dr. Mike Montross, for the valuable input throughout the process and challenging questions.

To the BAE staff – You make it happen - great work folks!

To the fellow graduate students - your work has offered inspiration.

To the undergraduate students - thanks for the help and keeping the lab cleaned up.

To Heather and my family - your unconditional support has been the foundation for me to build upon throughout the years.

TABLE OF CONTENTS

TABLE OF CONTENTS.....	iii
LIST OF FIGURES	vii
LIST OF TABLES	ix
Chapter 1: INTRODUCTION	1
1.1 Conversion of Lignocellulose.....	1
1.2 Project Objectives.....	2
Chapter 2: LITERATURE REVIEW	3
2.1 Lignocellulose Composition.....	3
2.2 Pretreatment.....	4
2.2.1 Necessity of Pretreatment	4
2.2.2 Sodium Hydroxide	4
2.2.3 Calcium Hydroxide.....	5
2.2.4 pH Neutralization and Alkali Recovery.....	6
2.2.5 Pretreatment Time Period	6
2.3 Solids Content.....	7
2.4 Pretreatment Performance Assessment	7
Chapter 3: CALCIUM HYDROXIDE EFFECTIVENESS	9
3.1 Summary.....	9
3.2 Introduction	9
3.3 Materials and Methods	11
3.3.1 Feedstock	11
3.3.2 Feedstock Composition.....	12
3.3.3 Treatment Vessel	12
3.3.4 Pumping System	13

3.3.5	Duration of Pretreatment Process	15
3.3.6	Recirculating Calcium Hydroxide Pretreatment	15
3.3.7	Pretreatment Controls	16
3.3.8	Sodium Hydroxide Pretreatment Control	16
3.3.9	Sample Conditioning Post-Pretreatment.....	16
3.3.10	NREL Enzymatic Hydrolysis	17
3.3.11	Sample Saccharification Analysis.....	18
3.4	Statistics.....	18
3.5	Results and Discussion	19
3.5.1	Relative Lime Effectiveness	19
3.5.2	High Solids Pretreatment	20
3.5.3	Water Conservation	20
3.5.4	Comparison of NaOH and Lime	22
3.5.5	Lime solution Reuse	25
3.5.6	Chemical Costs	25
3.6	Conclusion.....	26
Chapter 4:	IN-SITU ENZYMATIC HYDROLYSIS	28
4.1	Summary.....	28
4.2	Introduction	28
4.3	Materials and Methods	30
4.3.1	Substrate.....	30
4.3.2	Feedstock Composition.....	30
4.3.3	Pretreatment & Enzymatic Hydrolysis Vessel.....	31
4.3.4	Recirculating Lime Solution Pretreatment.....	32
4.3.5	Post Pretreatment Solids Conditioning.....	33

4.3.6	Enzymatic Hydrolysis Controls	33
4.3.7	In-Situ Bulk Enzymatic Hydrolysis	35
4.3.8	Glucose Contributions from Enzyme Addition	36
4.3.9	Sample Saccharification Analysis.....	37
4.4	Statistics.....	37
4.5	Results and Discussion	38
4.5.1	High Solids Impact	38
4.5.2	In-situ Bulk Enzymatic Hydrolysis Yields	39
4.6	Conclusion	43
Chapter 5:	FUTURE WORK.....	45
5.1	Recirculating Lime Solution Pretreatment Optimization	45
5.1.1	Recirculation Flow Rate	46
5.1.2	Pretreatment Time Period	47
5.1.3	Lime Solution Reuse.....	47
5.1.4	Initial Solids Loading Increase	47
5.1.5	Substrate Particle Size.....	48
5.2	Recirculating Cellulase Enzyme Solution Optimization	48
5.2.1	Bulk Enzymatic Hydrolysis Flow Rate.....	48
5.2.2	Enzyme Dosage & Timing.....	49
5.2.3	Hydrolysis Time Period & Temperature.....	49
APPENDICES	50
Appendix A.	Experimental Data	50
Appendix B.	Enzymatic Hydrolysis Protocol.....	52
Appendix C.	Sample SAS 9.4 Code	59
Appendix D.	Sodium Citrate Buffer Solution.....	60

REFERENCES	63
VITA.....	67

LIST OF FIGURES

Figure 1: Schematic of Lignocellulose Composition Pre & Post Pretreatment. Adapted from Kumar & Barrett 2009.	3
Figure 2: Up-flow Treatment Vessel left; Six Vessels in Use right	13
Figure 3: Recirculation system schematic	14
Figure 4: Experimental Pretreatment System	15
Figure 5: Comparison of lime loading rate, condition (static or recirc), and controls on 5mm Switchgrass pretreated for 7 days at 22°C. Error bars are standard deviation. Means with the same letter are not significantly different.	19
Figure 6: Washed/Unwashed Substrate Yield Comparison of 5mm feedstock pretreated for 7 days at 22°C. Error bars are MSE. Means with the same letter are not significantly different.....	21
Figure 7: SAS 9.4 MEANS (LSD) results for mean NREL hydrolysis glucose yields for recirculating lime and static NaOH 7-Day pretreatments at 22 °C. Comparisons on 5mm corn stover (cs) and switchgrass (sg) at two pH level (4.8 & 5.5). Error is MSE. Means with the same letter are not significantly different.	23
Figure 8: Up-flow Treatment Vessel left; Vessel with 38 gDM right	32
Figure 9: Experiment Pretreatment System	33
Figure 10: 76mm Switchgrass during Pretreatment.....	35
Figure 11: Experimental Bulk Enzymatic Hydrolysis System	36
Figure 12: High Solids Effect on mean glucose yields in NREL hydrolysis. Error is standard deviation.	38
Figure 13: Hydrolysis Method Comparison of 5mm Corn Stover. Error is MSE. Means with the same letter are not significantly different.	39
Figure 14: Pre & Post Enzymatic Hydrolysis of 5mm Corn Stover	40
Figure 15: Hydrolysis Method Comparison of 5mm Switchgrass. Error is MSE. Means with the same letter are not significantly different.	41
Figure 16: Switchgrass Particle Size Impact on Mean Glucose Yields. Error is MSE. Means with the same letter are not significantly different.....	42

Figure 17: Hydrolysis Method Comparison of 76mm Switchgrass. Error is MSE. Means with the same letter are not significantly different. 43

LIST OF TABLES

Table 1: Pretreatment Methods Overview. Adapted from Kumar & Bennet 2009	4
Table 2: SAS 9.4 ANOVA results showing efficacy of lime pretreatment	19
Table 3: Mean & standard deviation for data shown in Fig. 6	22

CHAPTER 1:INTRODUCTION

1.1 Conversion of Lignocellulose

Lignocellulosic biomass represents the largest pool of renewable polymerized carbon in nature in the form of woody and herbaceous biomass. The thermochemical conversion (combustion) of this lignocellulose to heat energy has been used by mankind for millennia. The biochemical conversion of this pool to a liquid energy source has been a focal point of researchers for many years, and while the technology exists that achieves this conversion, it has not reached the level of economic viability sufficient to induce widespread implementation as a second generation biofuel and biochemical source (Modenbach and Nokes 2013).

The widespread adoption of lignocellulosic carbon conversion not only requires a technical process that achieves economic viability but just as important is a steady supply of substrate; that substrate will inevitably come from rural agricultural areas. This leads to a system wide question of a centralized model where biomass is transported to an industrial facility to be converted and refined, or a distributed model where the products of the conversion process are transported (Eranksi and Dale 2011). The distributed model could be envisioned within a regional system where some portion(s) of the conversion process is carried out at the farm level and secondary processing occurs elsewhere. One may consider the objective to be a concentration of energy in order to lower the inherent transportation energy costs.

The first step in the conversion process involves a pretreatment that reduces the inherent resistance of lignocellulose to rapid degradation – degradation necessary to get access to the primary desirable component of cellulose. A multitude of effective pretreatments in different categories have been studied in the scientific community (Kumar, Barrett et al. 2009); chemical pretreatment is one prominent category. The vast majority of studies related to the chemical pretreatment of lignocellulose have been conducted at the laboratory scale with conditions that would not readily transfer to a typical production agricultural setting.

The need exists for a practical pretreatment process that readily transfers to an agricultural setting. A practical process would be one that is conducted in ambient

conditions, uses a relatively safe, inexpensive chemical that can be recovered, minimizes waste by-products requiring special disposal, and finally achieves a reasonable level of pretreatment. This work seeks to show that calcium hydroxide, also known as hydrated lime or lime, is a chemical that can meet these requirements and be a practical choice for an on-farm pretreatment process.

1.2 Project Objectives

The overall goal of this research is to demonstrate the effectiveness of calcium hydroxide (lime) as a pretreatment chemical for use in an on-farm biomass processing system. The process will be conducted in a high-solids environment that conserves resources and produces minimal process waste or dangerous by-products. The specific objectives are:

- i. Demonstrate the effectiveness of a recirculating calcium hydroxide solution relative to sodium hydroxide in a high solids system by comparing the post hydrolysis glucose yield.
- ii. Perform in-situ enzymatic hydrolysis to produce a fermentable stream of carbohydrates in a high solids system.

CHAPTER 2:LITERATURE REVIEW

2.1 Lignocellulose Composition

Both herbaceous and woody plant material is composed chiefly of lignocellulose – the three primary components are lignin, cellulose, and hemicellulose, constituting about 90% of the dry matter (Kumar, Barrett et al. 2009). Of these components, cellulose is the most sought after because it is homogeneous hexose polymer assembled from 7,000 to 15,000 glucose monomers in a predominantly crystalline structure. Hemicellulose is a heterogeneous polymer assembled with 500 to 3,000 monomers consisting of both pentose and hexose monomers. Hemicellulose is more easily hydrolyzed than cellulose due to its branched, amorphous structure. Surrounding the cellulose and hemicellulose and protecting them from degradation is lignin. Lignin is a complex, hydrophobic polymer composed of large phenolic monomers of coniferyl, coumaryl, and sinapyl alcohols with extensive crosslinking and covalent bonding with hemicellulose. The structure of lignin is random in nature contributing to its resistance to chemical, enzymatic and microbial attack (Nagwani 1992; Kumar, Barrett et al. 2009; Leisola, Pastinen et al. 2012; Carey 2014). Figure 1 is a schematic of typical lignocellulose structure and the desired post-pretreatment structure.

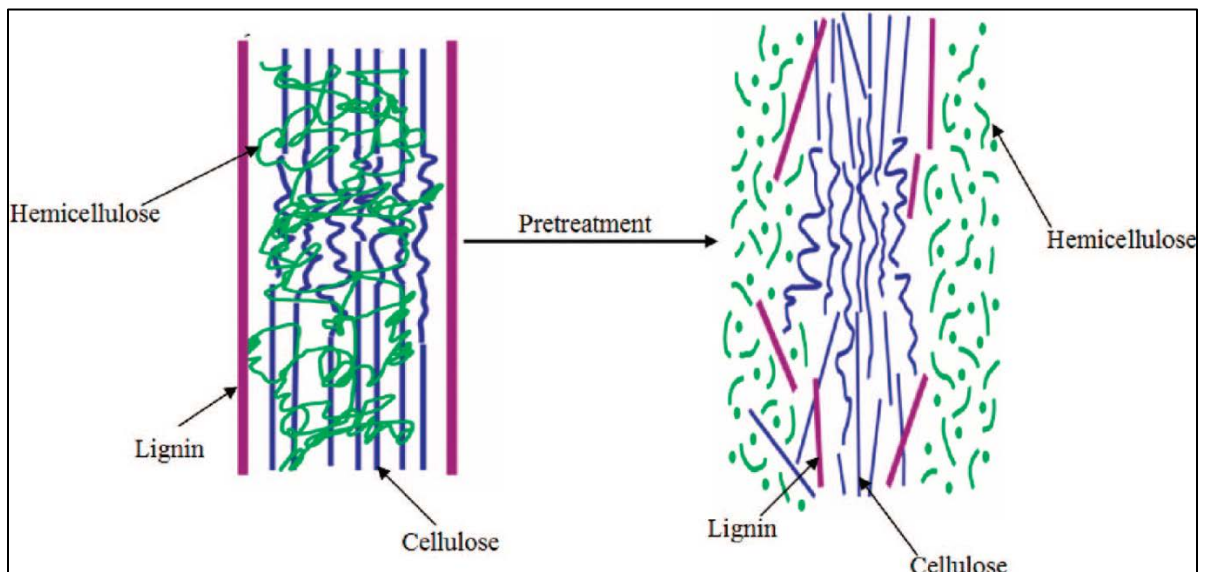

Figure 1: Schematic of Lignocellulose Composition Pre & Post Pretreatment. Adapted from Kumar & Barrett 2009.

2.2 Pretreatment

2.2.1 Necessity of Pretreatment

Pretreatment of lignocellulose is necessary to expose cellulose for enzymatic depolymerization, i.e., fermentable sugar production, at a rate that is economically feasible for the large scale production of biofuels (Kumar and Murthy 2011). Available pretreatments can be loosely categorized as physical, chemical, and biological (Kumar, Barrett et al. 2009). Table 1 below provides a brief overview of advantages and drawbacks of common pretreatment pathways used to enhance access to fermentable sugars.

Table 1: Pretreatment Methods Overview. Adapted from Kumar & Bennet 2009

Category	Pretreatment	Advantages	Drawbacks
physical	mechanical comminution	reduces particle size increasing surface area; reduces cellulose crystallinity	high energy consumption, equipment maintenance
chemical	acid hydrolysis	alters lignin structure and hydrolyzes hemicellulose	high cost, specialized equipment, inhibitory compound formation, chemical waste disposal
chemical	alkaline hydrolysis	increased accessible cellulose surface area, removes hemicellulose and some lignin	longer residence times required, potential for unrecoverable salts formation incorporated into substrate, potential inhibitory compound formation, chemical waste disposal
biological	fungal attack	degrades lignin and hemicelluloses, low energy requirements	yields can be low, process requires longer residence time, organism extracts energy from substrate

2.2.2 Sodium Hydroxide

Sodium hydroxide (NaOH) is a prominent hydroxide source found in literature studies on alkaline pretreatment (Kumar, Barrett et al. 2009; Xu 2009; Modenbach and Nokes 2014). Of the hydroxides studied, NaOH is frequently shown to produce to a greater percent reduction in lignin content and higher gross glucose yields after enzymatic hydrolysis in a shorter time period than lime under similar conditions (Xu

2009; Soares-Rodrigues 2015). NaOH is considered a viable pretreatment chemical when considering cost and availability, functionality in a wide variety of temperatures, loading rates, and substrates, and without demanding highly specialized equipment (Modenbach and Nokes 2014).

2.2.3 Calcium Hydroxide

This work uses the term “lime” to exclusively denote calcium hydroxide. Lime has been evaluated as a lignocellulosic pretreatment chemical in many studies (Chang, Burr et al. 1997; Kumar, Barrett et al. 2009; Ayeni, Hymore et al. 2013), resulting in a variety of recommended conditions for time and temperature. For pretreatment temperatures of 100-120 °C, treatment periods were defined in hours (Nagwani 1992; Chang, Burr et al. 1997), and for temperatures of 50-60 °C, the treatment periods were defined in days or weeks (Chang, Nagwani et al. 1998; Kim and Holtzaple 2005; Xu, Cheng et al. 2010). More recently there has been work done to reexamine the performance of lime at ambient temperatures (Xu 2009; Soares-Rodrigues 2015) and even below ambient temperatures (Khor, Rabaey et al. 2015). In general, these studies concluded that temperatures well above ambient are preferable to achieve the best glucose yield, however it should be recognized that elevated temperatures are themselves a form of pretreatment (Kumar, Barrett et al. 2009; Carey 2014).

Lime exhibits poor solubility in water and has the interesting property that the solubility increases with decreasing temperature. At 20 °C, 1.65 g/L of lime will dissolve into solution, whereas only 0.071 g/L at 100 °C (Association 2007); contrast the solubility curve with the high temperature recommendation for lime pretreatment and a logical disconnect is apparent. To provide context for lime, sodium hydroxide solubility at 20 °C is 1,110 g/L. Lime’s low solubility produces a less aggressive alkali solution by limiting the hydroxyl ion concentration available, hence a longer pretreatment period was typically recommended (Kim and Holtzaple 2005; Xu, Cheng et al. 2010; Yan, Li et al. 2015). All the referenced studies pretreat the substrates by adding water and solid lime to a treatment vessel.

Throughout the reviewed literature, a lime loading rate of 0.10 g/g dry matter (10% w/w) was the most commonly recommended value (Chang, Burr et al. 1997; Chang, Nagwani et al. 1998; Park, Shiroma et al. 2010; Xu, Cheng et al. 2010; Yan, Li et al.

2015). Lime loading rates in excess 10% (w/w) were tested and shown to produce little or no improvement to sugar yields, while increasing chemical costs, and wash volumes needed to neutralize the excess lime (Chang, Burr et al. 1997; Falls and Holtzappple 2011; Wang and Cheng 2011) and has even been shown to mildly (~4%) decrease yields with fixed wash water rates (Xu, Cheng et al. 2010; Wang and Cheng 2011). A study by Wang and Cheng found an 8-9% decrease of total reducing sugar yield when lime loading dropped from 10%(w/w) to 8% (w/w), with a strong linear decrease (slope of ~ 1.67gGlucose/gLime) below 8%(w/w) (Wang and Cheng 2011), while another study found a strong linear decrease of total reducing sugar with a slope of about 6.25 g/g lime for loading rates dropping from 10%(w/w) to 5%(w/w) (Chang, Burr et al. 1997). A study using corn stover measured the specific lime consumption at 7.3% (w/w) at the identified optimal conditions of 55°C over a 4 week period with aeration (Kim and Holtzappple 2005).

2.2.4 pH Neutralization and Alkali Recovery

The pretreatment process using alkali solutions results in final pH values typically above pH 10; neutralization is required to bring the pH to levels acceptable for enzymatic hydrolysis. The most common method noted in these studies is to wash the solids with de-ionized water (Kumar, Barrett et al. 2009; Xu, Cheng et al. 2010; Wang and Cheng 2011; Yan, Li et al. 2015), adding organic or mineral acids to the solids (Kim and Holtzappple 2005; Falls and Holtzappple 2011), or gaseous carbon dioxide to reduce pH and provide a method of calcium recovery as calcium carbonate with lime pretreatment (Chang, Burr et al. 1997; Park, Shiroma et al. 2010) . Most studies examined did not quantify wash water volumes but rather washed to achieve a neutral pH of the solids, however, Xu and Cheng's work tested two levels of wash water intensity: 100mL or 300mL per gram of dry matter(Xu, Cheng et al. 2010).

2.2.5 Pretreatment Time Period

The time periods studied in literature vary widely for lime pretreatment – from hours (Chang, Burr et al. 1997) to more than 16 weeks (Kim and Holtzappple 2005). The trend for the pretreatment time period was related to the temperature used – the higher pretreatment temperatures were associated with the short time periods, whereas ambient temperatures were aligned with longer periods. The high temperature and/or long

pretreatment periods, i.e., more severe, pretreatments have been shown to produce more compounds inhibitory to microbial fermentation along with carbohydrate degradation and loss (Kim and Holtzappple 2005; Kumar, Barrett et al. 2009; Du, Sharma et al. 2010; Modenbach and Nokes 2012; Modenbach and Nokes 2014).

2.3 Solids Content

The solids content of the pretreatment step impacts all aspects of the entire process including water use, material handling, and ultimately process economics (Modenbach and Nokes 2012). The majority of experiments reviewed were conducted at laboratory scale with initial dry matter solids loadings ranging between a nominal 5% and 10% (w/w) or conversely, 90% to 95% MC_{wb}. There is a general consensus in the literature that a high solids process is one operating at a solids loading at or greater than 15% (w/w) primarily due to the material handling transition from a slurry to stackable solids (Hodge, Karim et al. 2009; Modenbach and Nokes 2012). While high solids operation offers economic advantages through improved efficiencies, it is not without negatives. The lack of free water to facilitate chemical reactions, increased viscosity complicating material handling and mixing, and the potential to produce compounds inhibitory to hydrolysis and fermentation at higher concentrations are chief among them (Modenbach and Nokes 2012; Soares-Rodrigues 2015). The challenges associated with high solids pretreatment operations are also common issues shared with enzymatic hydrolysis operations (Kristensen, Felby et al. 2009; Modenbach and Nokes 2013).

2.4 Pretreatment Performance Assessment

There are many measures used in the literature to assess pretreatment performance such as: measuring compositional changes in lignin or cellulose, changes in pore size and porosity, cellulose crystallinity changes and degree of polymerization (Modenbach and Nokes 2014). Regardless of the pretreatment method, the most frequent and practical assessment is quantifying fermentable sugar yields resulting from enzymatic hydrolysis of the cellulose. Numerous studies quantify glucose, xylose, and total reducing sugars, however the most common sugar quantified is glucose as it has the longest history of industrial fermentation. The pH of the hydrolysis process depends on the specific enzyme used but is typically between pH 4.5 and pH 5.5. After neutralization, a buffering

medium such as sodium citrate is used to maintain the pH at the desired value during hydrolysis.

The predominant enzymatic hydrolysis protocol in the literature is from the National Renewable Energy Lab (NREL). NREL laboratory analytical procedure NREL/TP-510-42629 (Selig 2008) details a standardized method to conduct enzymatic hydrolysis and allow comparisons across studies. A key parameter of the protocol is the solids content used in the process – NREL enzymatic hydrolysis is conducted at about 2.7% total solids.

CHAPTER 3: CALCIUM HYDROXIDE EFFECTIVENESS

3.1 Summary

A study of a bulk lignocellulosic pretreatment process using a saturated lime solution flowing through the substrate in a recirculating manner was done to establish its suitability for use in an on-farm biomass processing system operating at high insoluble solids loading. The effectiveness of the pretreatment was determined by comparing the glucose yields from enzymatic hydrolysis with yields from the more common alkali sodium hydroxide as well as literature values from other lime pretreatment formats.

The impacts of post-pretreatment solids washing were found to be statistically insignificant so washing was eliminated and solids moved directly to hydrolysis. The comparison of enzymatic hydrolysis pH was tested at 4.8 and 5.5 and also found to be insignificant in this work.

The recirculating lime solution was first compared with static lime, water only, and no pretreatment to establish efficacy. The recirculating lime solution achieved yields statistically equivalent to static lime and far exceeded yields from water only and no pretreatment. The recirculating lime solution was next compared with a static NaOH pretreatment as a way to establish relative performance. The lime solution achieved glucose yields of 81-85% of NaOH depending on the substrate and the pH of the enzymatic hydrolysis. When compared with other studies on lime pretreatment on switchgrass, this work produced a mean glucose yield that exceeded (0.245 to 0.231 gG/gDM) with similar conditions or was approximately equal to (0.245 gG/gDM) even though the conditions in this work were far less energy intensive and more amenable to an on-farm setting.

3.2 Introduction

The vast majority of studies related to the chemical pretreatment of lignocellulose have been conducted at the laboratory scale with conditions such as elevated temperatures and pressures, finely ground particles sizes, and with chemicals and processes that produce wastes that require careful disposal. While these types of processes can produce a very effective pretreatment exposing the cellulose to widespread

degradation and high glucose yields, they can often be described as impractical or too expensive for a simple on-farm process. The process energy intensity during the pretreatment period obviously increases with any temperature and pressure other than ambient, resulting in a decrease of the possible net energy gain from the overall process as well as hampering process economics. From the perspective of a practical on-farm pretreatment system, conditions other than ambient present additional mechanical system complexity, increased capital, operational and maintenance costs inherent in system operation. A low cost practical biomass pretreatment method for large scale use in a high solids environment is needed for a biomass processing system to be implemented in an agricultural rather than an industrial setting.

Sodium hydroxide (NaOH) is a commonly used industrial chemical that is widely available and has been shown to be an effective pretreatment chemical even in ambient conditions. However, the use of NaOH on-farm presents challenges in that it is a more aggressive, hygroscopic alkali requiring enhanced awareness for safe storage and handling, is more expensive per unit mass than lime, and is not amenable to localized sodium recovery or disposal by use as a soil amendment.

Lime is a commonly used chemical with a broad range of applications in agriculture and industry. Prior work found in the literature has established that lime can be used as an effective pretreatment chemical. As a pretreatment chemical, lime has the distinct advantages of performing well at ambient conditions with minimal specialized equipment, personnel training for safe use, and the ability to be recovered as calcium carbonate and regenerated as calcium hydroxide via a lime kiln or disposed via land application as a soil amendment. Lime has the distinct disadvantage of limited solubility in water. The paradigm throughout the literature on lime pretreatment has the substrate mixed with lime and water to produce a slurry within a treatment vessel typically at or below 10% (w/w) substrate solids loading. The limited solubility of lime often results in unreacted lime solids in the substrate which require neutralization resulting in increased wash water volume or chemical neutralization with acids. Given the known advantages and disadvantages of lime as a pretreatment chemical, the hypothesis of this work is that the disadvantages (limited solubility) can be overcome, and when combined with the

advantages, lime can achieve a comparable biomass pretreatment effectiveness as sodium hydroxide, and thus is a more practical chemical choice for on-farm use.

To test this hypothesis, two objectives were developed. This work seeks to use a pretreatment paradigm shift by recirculating a saturated lime solution void of lime solids through the substrate in a high solids environment; to ensure solution saturation, an in-line filter is used to trap lime solids. The primary objective of this study was to demonstrate the practical effectiveness of lime as a pretreatment chemical for an on-farm lignocellulosic biomass high solids (14-16% (w/w)) pretreatment system by comparing the post enzymatic hydrolysis glucose yields of lime and sodium hydroxide. The secondary objective of this work was to test the impact of no neutralization of the substrate either by washing or chemical addition, but rather relying on the enzymatic hydrolysis buffer to establish the appropriate pH level. The pH of hydrolysis was tested in an attempt to optimize glucose yields and also in consideration of a larger system. The ability to hydrolyze at a higher pH should be an advantage when moving from a basic pretreatment to an acidic enzymatic hydrolysis. By removing a washing step, fragmented carbohydrates may be preserved, fresh water demand is reduced, and the system has reduced operational infrastructure requirements while reaping some environmental benefits.

3.3 Materials and Methods

3.3.1 Feedstock

The substrates used for this work were corn stover and switchgrass. The corn stover was Becks 6175 hybrid, harvested in the fall of 2013 at the C. Oran Little Research Center in Woodford County, KY. The Alamo switchgrass was harvested in February 2014 at the North Farm in Fayette County, KY. Both substrates were baled and stored in barns and moved to the lab for use as needed. The materials were air dried in the lab to a moisture content of about 8.5% w.b.. For the nominal 5mm particle size experiments, the feedstock was ground to pass a 5mm screen in a C.S. Bell No. 10 hammer mill, and stored in standard plastic feed sacks until use. The stored moisture content varied seasonally but held within a range of 7% to 9% w.b. Moisture content was measured

with an Ohaus MB35 Halogen moisture analyzer. The substrates were not sterilized before pretreatment.

3.3.2 Feedstock Composition

The composition of the lignocellulosic feedstocks used in this work was not analyzed. The difficulty in obtaining a true representative biomass sample coupled with variability of results produced by the oft used protocol NREL/TP-510-42618, Determination of Structural Carbohydrates and Lignin In Biomass, prompted the use of average composition values in all calculations as a way to reduce error introduced from compositional analysis. The work by the North Central Center provided the average values of biomass composition used in this work – primarily the mean cellulose content for corn stover and switchgrass (SunGrant 2007). This work used 37.5 %(w/w) cellulose content as the basis for all calculations for both feedstocks. The use of an average value does not negatively impact this work since all the comparisons examined relative performance instead of absolute values.

3.3.3 Treatment Vessel

The treatment vessel was designed as an up-flow reactor that could hold up to approximately 39 grams of dry matter as shown in figure 2. The up-flow configuration was used to better eliminate all air from the vessel and feedstock to prevent neutralization from atmospheric carbon dioxide. The vessel was a one pint canning jar, McMaster-Carr part # 3231T43, with standard tin bands and lids. The center of the jar bottom was drilled to accept a removable hose connection, Chemglass part # CG-1563-01, which connected to the supply side of the pump; a hole was punched in the replaceable lid to accept a bulkhead fitting, McMaster-Carr part # 5463K83, to connect the return flow line. Stainless steel wire mesh screens were used in the vessel above and below the feedstock to prevent solids from leaving the vessel and to inhibit the development of preferential flow paths through the feedstock; the screens were 20 mesh, 0.16” wire diameter, McMaster-Carr part# 9317T81. The vessels were loaded by placing a screen on the bottom of the vessel and then taring on a balance, loading with each vessel with a total mass calculated to yield 38 - 39 grams of substrate dry matter, and then capped with a screen before installing the lid and band. Six treatment vessels were placed on an elevated platform for each experimental run as shown in figure 2.



Figure 2: Up-flow Treatment Vessel left; Six Vessels in Use right

3.3.4 Pumping System

In order to operate six vessels, two pump drives, each with three pump heads, were used to provide flow. The pump drives were Masterflex Model No. 7520-50; the pump heads were model 77800-60. The tubing was Masterflex Puri-flex tubing L/S 17, Cole-Parmer catalog number EW-96419-17. The pumps were drawing the saturated solution from a four liter glass reservoir, forcing flow through each vessel and back to the reservoir. The pump drives were operated at about 50 rpm, delivering about 140 mL/min to each vessel, resulting in a vessel volume turnover rate of 42 times per hour. This high flow ensured no limitation on the hydroxyl ion availability. Further, the use of three pump heads on each drive resulted in a significant torque requirement, hence the pump speed was found to be just fast enough to prevent overheating the motor. A drive with a single pump head was used to maintain a saturated calcium hydroxide solution by recirculating the reservoir contents at about 280 mL/min through a filter housing,

McMaster-Carr part # 9979T21, with a 5 micron synthetic water filter, McMaster-Carr part # 5445T51. The filter was sized to trap the lime solids on the upstream side of the filter, thus preventing dispersal into the reservoir and throughout the substrate. Figure 3 provides a simple schematic of the system. Figure 4 shows the experimental pretreatment system.

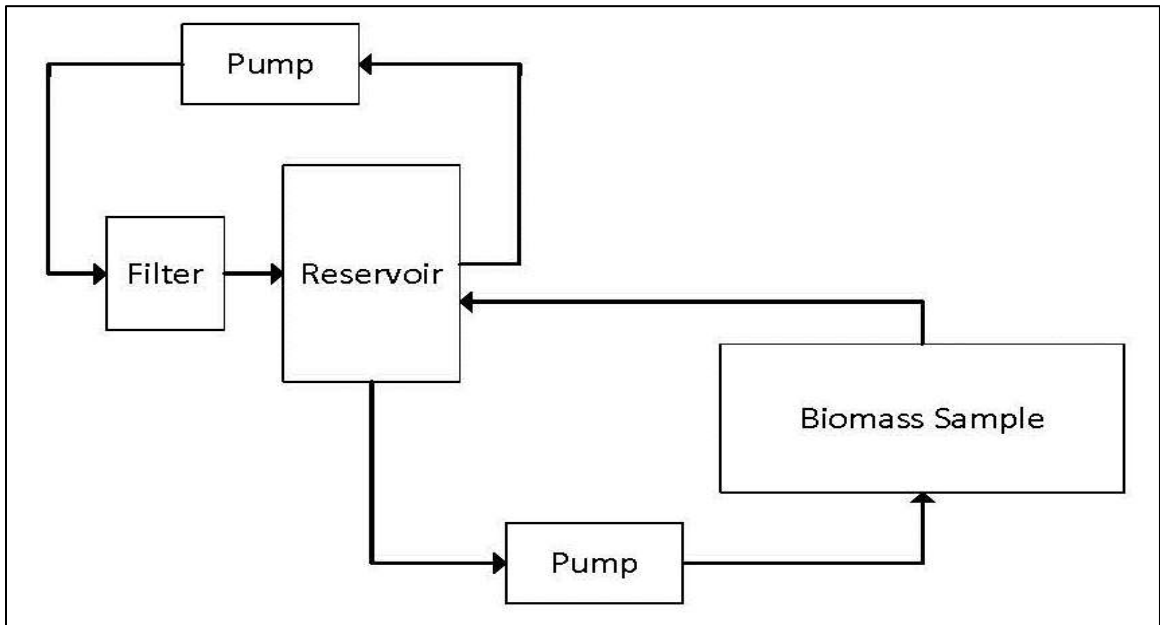

Figure 3: Recirculation system schematic



Figure 4: Experimental Pretreatment System

3.3.5 *Duration of Pretreatment Process*

A 7-day pretreatment period was chosen partly as a matter of schedule convenience within the laboratory and to generally align with other studies on lime pretreatment at similar conditions (Xu 2009; Xu, Cheng et al. 2010; Soares Rodrigues 2015). Further, a weekly schedule would conform well to an on-farm process where labor can be consistently scheduled.

3.3.6 *Recirculating Calcium Hydroxide Pretreatment*

The calcium hydroxide (CAS No. 1305-62-0) used for all experiments was Acros Organics catalog number 21918, lot number A0323480. The lime was loaded at 10% (w/w) of the total mass of dry matter. The lime was weighed out, added to about one liter of water, agitated and then pumped into the filter. Once all the lime solids were in the filter, the reservoir recirculation process began to ensure the reservoir contained a saturated lime solution; pretreatment recirculation immediately followed the addition of

lime to the filter. Once the pretreatment period elapsed, the recirculation pump drives were reversed and the lime solution was pumped out of the treatment vessels to the reservoir and reused for the next pretreatment run. This process was followed for all recirculating pretreatment runs. The pretreatment process was run for 7 days at ambient laboratory temperature of 22°C.

3.3.7 Pretreatment Controls

The controls experiments were done with a) no pretreatment (raw substrate), b) recirculating water, and c) lime without recirculation. The raw substrate control was used in enzymatic hydrolysis without modification. The recirculating water control experiments were done with a separate de-ionized (DI) water reservoir. For the static controls, i.e., no recirculation, the pretreatment vessels were the same one-pint canning jars and lids sans holes for fittings. The static pretreatment was carried out with the same substrate but only 20 grams dry matter to allow space for mixing, 10-15mL DI water per gram dry matter added to result in about a 6.25% - 10% solids loading, then the lime added, and the contents thoroughly mixed. Static pretreatment experiments with lime were done with both a 5% and 10% w/w chemical loading rates. The pretreatment process for controls was run for 7 days at ambient laboratory temperature of 22°C.

3.3.8 Sodium Hydroxide Pretreatment Control

Sodium hydroxide (NaOH), the most studied alkali lignocellulosic pretreatment chemical (Kumar, Barrett et al. 2009), was used as the comparative benchmark to assess lime pretreatment performance based on enzymatic hydrolysis glucose yields. The pretreatment was done in the same vessel configuration as other static controls. NaOH conditions were 10 % (w/w) chemical loading, 20 gDM and 200mL DI water for a 10% dry matter solids loading (Modenbach and Nokes 2014). Both switchgrass and corn stover (n=3 vessels each) were pretreated for 7 days at ambient laboratory temperature of 22 °C. All NaOH pretreated materials were washed to a neutral pH without regard to total wash water volume.

3.3.9 Sample Conditioning Post-Pretreatment

Samples from some early work were washed before enzymatic hydrolysis to test the impact of washing versus not washing the substrate. Raw substrate and solids pretreated

in the static control experiments were all washed without quantifying rinse water volume. The solids were placed on a coffee filter, McMaster part # 4739T3, in a Buchner funnel with applied vacuum and rinsed with DI water until the solids were approximately pH 7; the pH was monitored by placing standard laboratory pH paper on the solids. Washed solids went directly to enzymatic hydrolysis. Unwashed solids were moved directly to enzymatic hydrolysis with no post-pretreatment conditioning.

3.3.10 NREL Enzymatic Hydrolysis

Substrate (washed or unwashed) was enzymatically hydrolyzed without drying. Enzymatic hydrolysis was done according to NREL Protocol NREL/TP-510-42629(appendix B) with each sample divided and treated in triplicate. Moisture content was determined using an Ohaus MB35 Halogen moisture analyzer. A commercial cellulase enzyme was used for saccharification.

The initial cellulase enzyme used for experiments was American Labs Inc. (ALI), Cellulase 150,000 CU/G, Lot No.: ALI14175-04; ALI cellulase was in a powdered form and was produced using *Trichoderma longibrachiatum*. The ALI cellulase activity contained 3 FPU/mg protein, 11.6 mg protein/100mg enzyme powder (Carey 2014). A stock enzyme solution was made that resulted in a 60 FPU per gram cellulose loading rate for each sample.

As a result of comparison testing of glucose yields along with ease of use, a switch was made to a commercial liquid cellulase enzyme - Novozyme CTec2, lot no. VCS00002. Novozyme enzyme replaced the ALI enzyme in all remaining experiments. The experimental results produced by each enzyme were kept distinct from another, i.e., no cross-enzyme comparisons were made. The Novozyme enzyme preparation is provided in a liquid format; per the CTec2 application sheet, the enzyme preparation was loaded at the manufacturer recommended dosage of 30% w/w of cellulose. CTec2 has been reported to have between 80 FPU/mL (Xu 2009) and 120 FPU/mL (Vivekanand, Olsen et al. 2014). Using a measured density of 1.17g/mL, a 30% (w/w) loading rate would translate to a loading rate in the range of 20-30 FPU per gram cellulose.

In all experiments, enzyme blanks and filter paper controls (Whatman #1 filter paper) were prepared and included in triplicate for each enzymatic hydrolysis event. The enzyme blanks quantified glucose additions accompanying the enzyme and the filter

paper provided an indication of the efficacy of the enzyme. A 0.1M sodium citrate buffer was used for pH control during hydrolysis. The impact of hydrolysis pH was tested at pH 4.8 and pH 5.5. NREL hydrolysis process was performed in a shaking table incubator for 72 hours at 50 °C and 150 RPM. After 72 hours, the enzymatic hydrolysis process was stopped by placing the samples in a 93 °C water bath for 15 minutes to denature the enzyme protein. The samples were cooled on the bench, vortexed for 5-10 seconds and 1.5mL decanted into labeled micro-centrifuge tubes. The samples were then centrifuged at 5,000 RPM for 10 minutes. Post centrifugation samples were moved directly to an YSI 2900 biochemistry analyzer for glucose measurement.

3.3.11 Sample Saccharification Analysis

The YSI 2900D biochemistry analyzer used YSI membrane part # 2365 for glucose measurement. The instrument was calibrated before each analysis event with YSI part # 2776, 2.5 g/L glucose, resulting in an analysis range of 0.05-25 g/L glucose. After calibration, the measurement linearity was confirmed using YSI part #1531 glucose standard at 9.0 g/L. The samples to be analyzed were placed in a 24 well tray in a pre-determined random order to ensure any instrument drift is randomized. Four 9.0 g/L standards and two DI water standards were included as a quality control measure with each group of samples analyzed.

3.4 Statistics

The data were compiled in a spreadsheet with appropriate sample notation. The data were imported into and analyzed in SAS version 9.4 using a PROC GLM model and MEANS (LSD). The dependent variable was the yield in grams glucose per gram dry matter (gG/gDM). The independent variables included substrate type, pretreatment chemical, chemical loading rate, pretreatment condition (recirculation or static), sample conditioning post-pretreatment, hydrolysis pH, and treatment date. The SAS model was used to identify insignificant independent variables for removal from the model.

3.5 Results and Discussion

3.5.1 Relative Lime Effectiveness

The pH at the end of the pretreatment period was determined with pH paper; treatments with 10% (w/w) lime loading rates were consistently above pH 11. The samples with a 5% (w/w) lime loading rate had a final value between pH 6 and pH 7, indicating that the hydroxyl ions had been fully reacted.

Table 2: SAS 9.4 ANOVA results showing efficacy of lime pretreatment

Source	DF	Type I SS	Mean Square	F Value	Pr > F
chem	2	0.328	0.164	345.01	<.0001
cond	2	0.048	0.024	51.49	<.0001
Error	46	0.022	0.0005		
Corrected	50	0.399			

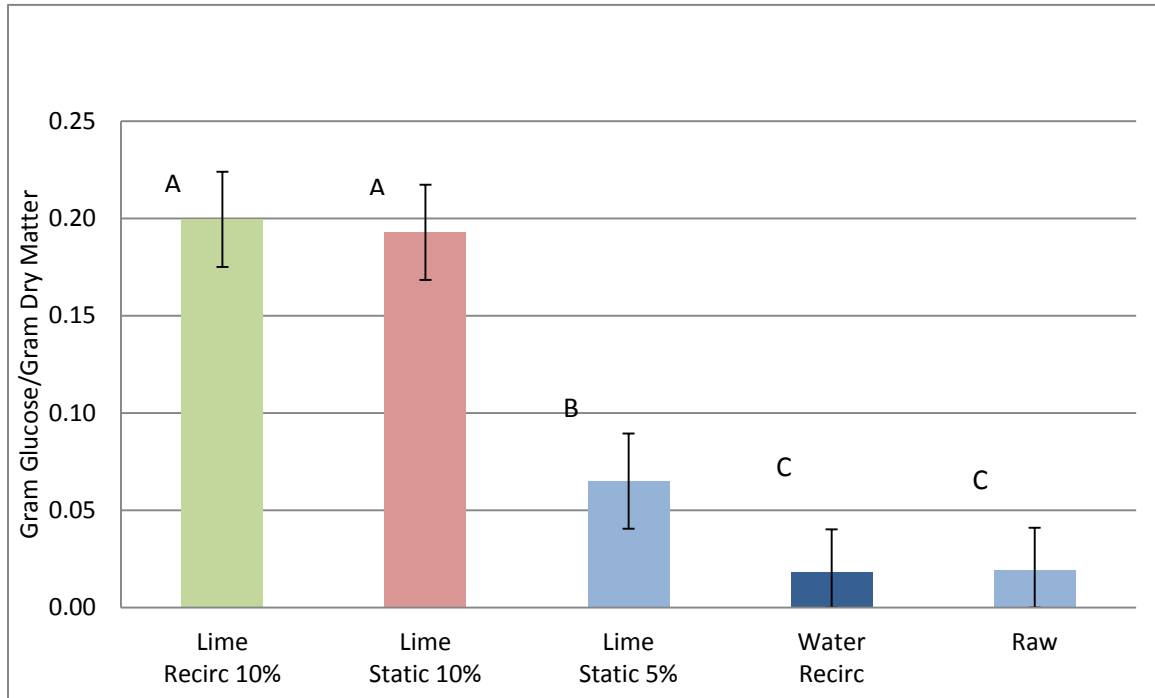

Figure 5: Comparison of lime loading rate, condition (static or recirc), and controls on 5mm Switchgrass pretreated for 7 days at 22°C. Error bars are standard deviation. Means with the same letter are not significantly different.

Table 2 presents the ANOVA results from SAS GLM procedure. Figure 4 presents the mean values and standard deviations for each treatment. SAS MEANS (LSD) tests, conducted at an alpha value of 0.05, showed lime at a 10% (w/w) loading rate significantly outperformed water, no pretreatment, and lime at a 5% (w/w) loading rate and showed no significant difference between recirculation and static treatments at the 10% (w/w) loading rate. As a result of these experiments, no additional work was done with water only pretreatment, lime loading rates below 10% (w/w), or static lime pretreatments since the performance of a recirculating system was confirmed to be at least as good as a static pretreatment in terms of glucose yield.

3.5.2 High Solids Pretreatment

After initial experiments establishing the effectiveness of a recirculating lime solution (see figure 4), the initial insoluble solids loading was increased to about 38 gDM (a full vessel). After pretreatment, the vessels would free drain about 200mL of solution depending on substrate porosity and void space within the vessel. With 38 grams of dry matter, the pretreatment process in each vessel would see an effective insoluble solids content between 14 - 16% (w/w), constituting a high solids pretreatment process. By retrospective consideration, the increased solids loading did not negatively impact enzymatic hydrolysis yields as evidenced by glucose yields batch to batch as can be seen by comparing figure 5 yields with those shown in figure 6.

3.5.3 Water Conservation

The data from lime pretreated 5 mm substrate (switchgrass and corn stover) for washed/unwashed comparisons were parsed in SAS 9.4. Results from SAS MEANS (LSD) for yield with an alpha of 0.05 were used produce figure 5. The mean value for the washed treatments was 0.271 gG/gDM and 0.264 gG/gDM for the unwashed samples. Given that there was no statistically significant difference between the treatments, all washing for recirculated lime pretreated substrate was terminated. The hypothesis that lime is a practical choice for on-farm to pretreat herbaceous biomass in a high solids unwashed format seems reasonable.

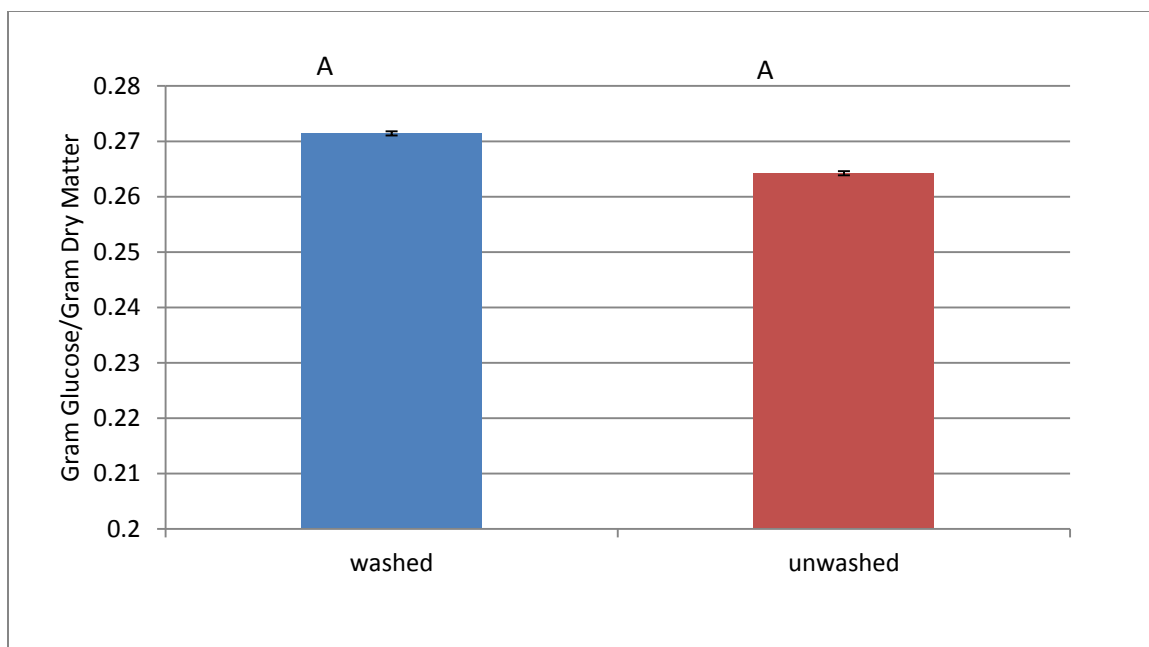

Figure 6: Washed/Unwashed Substrate Yield Comparison of 5mm feedstock pretreated for 7 days at 22°C. Error bars are MSE. Means with the same letter are not significantly different.

None of the previously referenced studies used a recirculating saturated solution devoid of undissolved lime, so washing or acid neutralization was required. The static treatments in this work with 10% (w/w) lime loading required more wash water than the recirculating samples to reach a neutral pH with the same loading rate due to the presence of unreacted lime, confirming previous findings from our lab (Soares Rodrigues 2015). In this work, unwashed solids were free drained of pretreatment solution in-situ, removed from the treatment vessel and taken directly to enzymatic hydrolysis. The buffer used in hydrolysis was the same in both cases; using unwashed solids had no detrimental effects on the final hydrolysis pH.

At laboratory scale, the environmental impact of washing at 100 - 300 mL per gram of dry matter (Xu, Cheng et al. 2010; Wang and Cheng 2011) is negligible. However, scaling that wash water volume to a theoretical 100-ton (~91 tonnes) bunker, 36'W x 50'L x 12' H (~11m W x 15m L x 4m H), with one-pass washing results in a requirement of 2.4-7.2 x 10⁶ gallons (~ 9 – 27 x10³ m³) of water. Such a considerable volume can no longer be considered environmentally insignificant with respect to water supply or

disposal, nor economically insignificant with respect to energy and infrastructure requirements.

3.5.4 Comparison of NaOH and Lime

Results from SAS 9.4 MEANS (LSD) tests with an alpha value of 0.05 were used to construct figure 6 below; the figure compares pretreatment chemical, the enzymatic hydrolysis pH, and substrates. Table 3 provides the mean values and standard deviation of the yield data for each condition shown in figure 6.

Table 3: Mean & standard deviation for data shown in Fig. 6

Figure	Lime Glucose Yield (gG/gDM)	NaOH Glucose Yield (gG/gDM)	Yield Ratio of Lime/NaOH
6(A)	0.286 ± 0.031	0.335 ± 0.052	85%
6(B)	0.271 ± 0.045	0.334 ± 0.032	81%
6(C)	0.245 ± 0.020	0.293 ± 0.035	84%
6(D)	0.243 ± 0.038	0.293 ± 0.020	83%

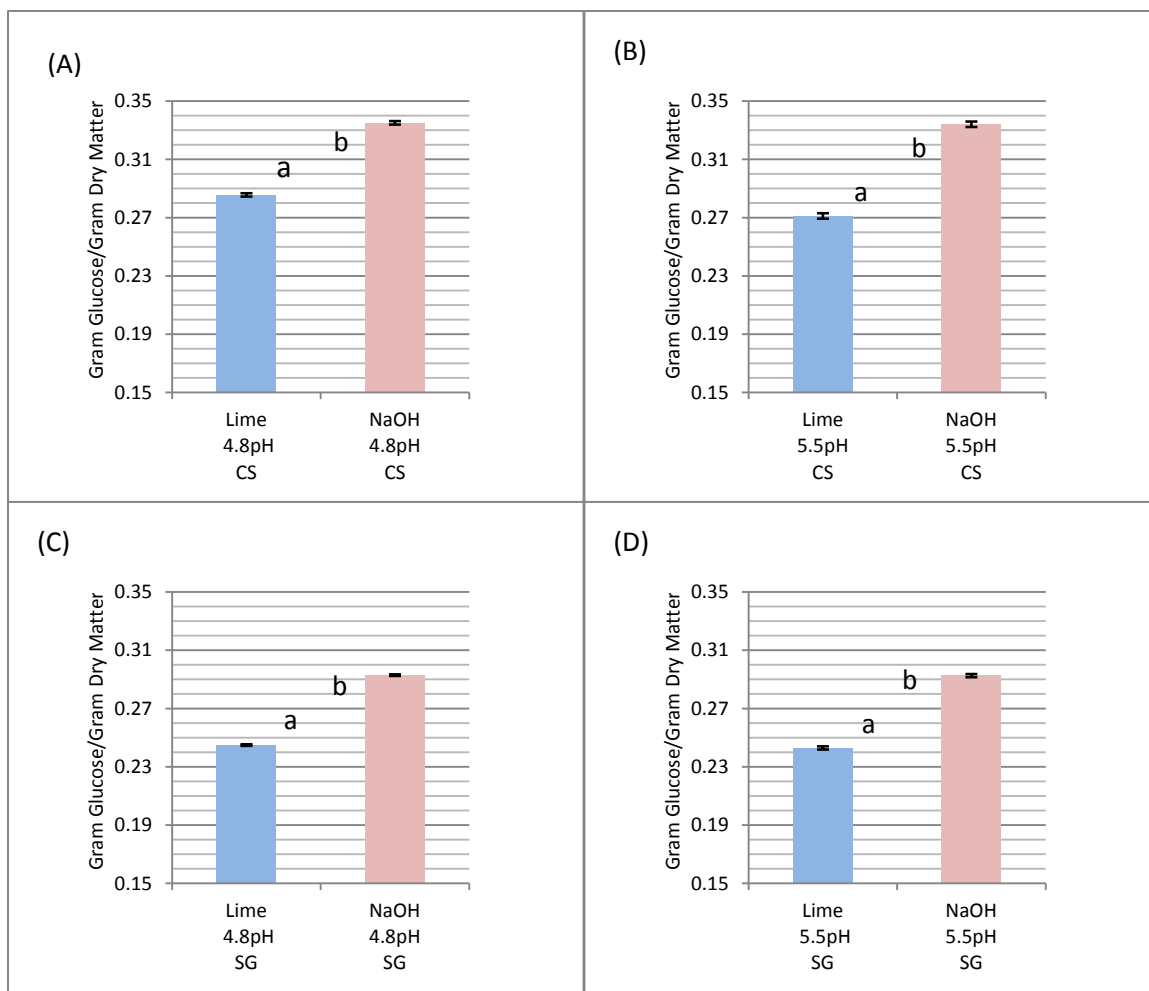

Figure 7: SAS 9.4 MEANS (LSD) results for mean NREL hydrolysis glucose yields for recirculating lime and static NaOH 7-Day pretreatments at 22 °C. Comparisons on 5mm corn stover (cs) and switchgrass (sg) at two pH level (4.8 & 5.5). Error is MSE. Means with the same letter are not significantly different.

The substrate comparison showed a significant difference ($p < 0.05$) between corn stover and switchgrass as clearly shown in table 3 - an expected result witnessed throughout the literature. The substrate comparison was done to ensure reasonable performance of the recirculating pretreatment process on both substrates.

The enzyme application guide (Novozyme 2010) suggests that hydrolysis be carried out in a pH range 5 to 5.5; this advice was confirmed in practice - the pH of hydrolysis was not a significant variable for the values tested ($p < 0.05$) in this work regardless of substrate. A potential explanation for a lack of significance could be the variance

associated with each pretreatment and enzymatic hydrolysis event exceeded that variance associated with changed hydrolysis pH.

The glucose yields of lime pretreated switchgrass shown in figure 6 C, D meet or exceed those found in two studies using switchgrass. In figure 3 (b) of Chang, Burr et al, 1997, the authors show 72 hour hydrolysis glucose yields of pretreated switchgrass (pretreatment conditions 121°C, 2hrs, 10% (w/w) lime, 10% total solids, 38%(w/w) cellulose) achieving between 0.24- 0.25 gG/gDM. It should be noted that the study used switchgrass ground to a -40 mesh particle size ($\leq 0.420\text{mm}$) and used acetic acid to neutralize the solids and then applied a correction factor for acetate inhibition of the enzymes used. The comminution energy requirements coupled with the high temperature requirement casts doubt on the practicality of such an approach in an on-farm scenario.

In his 2009 dissertation, appendix A, Xu reports an average glucose yield of 0.231gG/gDM for lime (pretreatment conditions: 21 °C, 96hrs, 10% (w/w) lime, 10% total solids, 38%(w/w) cellulose). Xu used switchgrass ground to pass a 2mm screen, pretreated in a static condition and washed the solids before enzymatic hydrolysis. Xu also studied NaOH with conditions similar to this work (21 °C, 96hrs, 20% (w/w) NaOH, 10% total solids loading) and reported an average glucose yield of 0.263 gG/gDM – Xu's glucose yield for lime pretreatment was 87% of the NaOH pretreatment – a similar yield ratio as this work.

The glucose yields of lime pretreated corn stover shown in figure 6 A,B exceed those found in Kim and Holtzaple 2005. In this work the authors examined the impact of temperature, time, and oxidative conditions on the lime pretreatment of stover. Table 3 reports the maximal yield (no standard deviation was reported) for a series of conditions; for the most similar set of conditions (25 °C, non-oxidative, 50% (w/w) lime, 10% total solids loading, 6mm particle size, 16 week pretreatment), a value of 67% glucose yield (g glucan hydrolyzed/g glucan in raw biomass) is reported for stover consisting of 36% glucan (Kim and Holtzaple 2005). Thus, the best reported yield was 0.240 gG/gDM for conditions similar to this work in which the mean yield was 0.286 gG/gDM. If Kim's yields were based on 37.5% (w/w) cellulose content as used in this work, the yield rises to 0.251gG/gDM but is still 12% less. The authors identified the optimal conditions as 55 °C, aerated substrate, four week treatment time, consuming 0.073 g lime/gDM. The

best yield for these conditions was a 91% glucose yield, resulting in 0.341 gG/gDM using a cellulose content of 37.5% (w/w). The author's optimal conditions resulted in only a 19% increase for the mean stover yield reported in table 3 of this work. The 16 week pretreatment period at ambient conditions or the 4 week period at 55 °C combined with hydrochloric acid neutralization of the solids would appear to be a less attractive on-farm process in terms of infrastructure, time, and glucose yields than the process in this work.

3.5.5 Lime Solution Reuse

The use of a recirculating lime solution with lime solids filtration was not found in the literature and so presents a novel approach. Once the pretreatment process has been completed, the solution is pumped off and stored in the reservoir, to be used again on the next batch. The reservoir filtration prevents the dispersion of insoluble lime solids throughout the substrate, and allows any unreacted lime to be present for the next batch – this approach conserves lime, minimizes or possibly eliminates wash water, while simultaneously ensuring a fully saturated solution. The use of the filtration and the reuse of the lime solution during the extent of these experiments did not negatively impact glucose yields evidenced by consistent glucose yields from batch to batch, as well as by comparison with the results of others' work. The lime solution was sampled on two separate occasions, the samples centrifuged and analyzed on the YSI without modification. In both cases, glucose was not detectable. It is reasonable that there may be some soluble non-structural sugars present in the solution, but the mild pretreatment conditions favor carbohydrate retention in the solids. Additionally, the presence of divalent calcium ions has been suggested as protective of carbohydrates by a crosslinking effect under alkaline conditions (Xu 2009; Wang and Cheng 2011; Yan, Li et al. 2015).

3.5.6 Chemical Costs

The costs for lime or NaOH at the laboratory scale are not a consideration but become a factor worthy of consideration at the farm scale. To that end, a bulk price quote for both calcium and sodium hydroxides was obtained from a national chemical company for 25 tons delivered to Lexington, KY (Brenntag 2015). The lime was quoted at \$225/ton, while NaOH (caustic flakes/pellets) was quoted at about three times the cost of lime at \$680/ton. Using the mean glucose yields from figure 6A and the pretreatment conditions in this work, the bare chemical cost per 100kg of glucose produced is \$8.67 for lime and

\$22.38 for NaOH, or 2.6 times the cost for only about a 17% glucose yield increase. A different perspective on performance differences and cost would be that about 300 kg of NaOH pretreated corn stover dry matter is required to produce 100kgs of glucose, whereas about 350 kg of dry matter would be needed for lime pretreated stover.

3.6 Conclusion

In her 2015 thesis comparing hydroxyl sources, Rodrigues reported that lime pretreated 2mm stover (20 °C, 10% (w/w) lime, 7 days pretreatment, 40% total solids) yielded 0.037 gG/gDM, while NaOH under similar conditions yielded 0.183gG/gDM. The performance of NaOH relative to lime in her work coupled with a wash water requirement for lime that was three times that of NaOH demonstrates the impact of lime's poor solubility. The yields were likely adversely affected by the high solids content, or conversely by the lack of free water. While not as extreme Rodrigues work, the effective solids content of the treatment process in this work qualifies as high solids (Modenbach and Nokes 2012). The value of the recirculating solution to ameliorate some portion of high solids negative impacts to lime pretreatment is evidenced by the glucose yield comparisons.

A key aspect of the recirculating system is the absence of undissolved lime particles in the substrate that require neutralization after the completion of the pretreatment. This work has shown that pretreated solids can transition directly to enzymatic hydrolysis without a washing step after the lime solution has been pumped off. The sodium citrate hydrolysis buffer was shown to be sufficient to adjust and maintain the system pH at an acceptable level. The environmental and economic values of conserving water by not washing the solids were not explicitly investigated, but the value can be implicitly recognized as a positive aspect for an on-farm pretreatment system.

The inverted temperature-solubility curve of lime in water supports operating at the lower temperatures one would expect to find in an on-farm system. The freedom to conduct a lime based pretreatment at ambient temperatures above the freezing point is a benefit in terms of energy accounting and system simplicity – both very important considerations. Additionally, spent lime solution can be recycled by recovering the calcium via carbonation or land applied as a soil amendment whereas sodium wastewater cannot be land applied without sodium recovery due to salinization risks.

Although the mean glucose yield for lime pretreatment was only 81%-85% of the NaOH yields in this work, the bare chemical costs show a lower cost per kilogram of glucose for lime pretreatment. When all the factors, such as cost, safety, ease of use, infrastructure requirements et al. are considered, lime represents a practical chemical choice for an on-farm pretreatment chemical.

CHAPTER 4: IN-SITU ENZYMATIC HYDROLYSIS

4.1 Summary

The recirculating lime solution pretreatment has previously been shown to be as effective on 5 mm substrate as other lime pretreatments with extended pretreatment times, smaller particle sizes, and harsher conditions. The effectiveness of bulk enzymatic hydrolysis of bulk recirculating lime pretreated lignocellulosic substrate was assessed by comparison with standard NREL hydrolysis glucose yields. The results of this work suggest a 20-25% yield reduction for bulk enzymatic hydrolysis of 5 mm substrate as configured and operated. However, the recirculating system produced higher mean yields than an NREL hydrolysis modified to increase the insoluble solids loading to levels at or near that of the bulk process. Thus the recirculating in-situ enzymatic hydrolysis approach ameliorates some of the inhibiting aspects associated with unmodified high solids enzymatic hydrolysis but falls short of the glucose yields of a standard NREL enzymatic hydrolysis.

To assess performance on a particle size better suited to material handling equipment typically found in an agricultural setting, 76mm switchgrass was pretreated and hydrolyzed in both a recirculating bulk and low solids method. A 14-fold increase in particle size resulted in a 20-25% decrease in glucose yields when compared with the 5mm substrate in high solids bulk hydrolysis and about a 40% decrease relative to a low solids NREL hydrolysis. When the 76mm pretreated substrate was enzymatically hydrolyzed in a low solids standard NREL method, there was no significant difference between the bulk and standard approaches. This suggests that the lack of carbohydrate accessibility from insufficient pretreatment is a greater limitation than the hydrolysis method.

4.2 Introduction

The conversion of lignocellulose to biofuel must be economically viable in order to compete with petroleum based liquid fuels. The previous chapter highlighted the effectiveness of a saturated lime solution pretreatment relative to the more common alkali sodium hydroxide at a reduced cost. The next step in the conversion process is the depolymerization of cellulose into glucose monomers suitable for microbial fermentation.

In an on-farm biomass bulk processing scenario it would be ideal to pump off the lime pretreatment solution and initiate a bulk enzymatic hydrolysis in-situ at a high solids loading, without extensive infrastructure to wash or mix solids, avoid moving solids between vessels or reducing the solids loading. The solids content of any step throughout the lignocellulosic conversion process ultimately impacts the system economics.

There is a general consensus in the literature that a high solids process is one operating at a solids loading at or greater than 15% (w/w). There is also a general consensus in the literature that the use of a high solids loading during enzymatic hydrolysis results in a decreased conversion of the cellulose to glucose. This apparent axiom has been characterized as the “solids effect” (Kristensen, Felby et al. 2009). The cause(s) of the decreasing yields revolves around mixing, mass transport and free water, product inhibition of the enzyme system, and increased concentrations of inhibitory compounds. A key observation taken from the literature was the approach to enzymatic hydrolysis, in either low or high solids format, was the paradigm of moving the solids to hydrolysis and mixing the substrate in a static enzyme solution.

The primary objective of this work was to alter the paradigm and enzymatically hydrolyze the substrate in-situ, i.e., bring the enzyme to the substrate in a flow-through process and by doing so potentially eliminate the need for substrate mixing while operating in a high solids environment within the treatment vessel itself. Additionally, the use of a flowing enzyme solution establishes the need for a reservoir to serve as a pump supply and return point. The reservoir could be sized to contain a volume, such that when considering the solids content of whole system, the system could be characterized as a low solids system. The low solids aspect of the system could potentially have a positive impact on the normally attributed negatives of high solids enzymatic hydrolysis.

The secondary objective of this work was to use the same bulk in-situ hydrolysis with a substrate particle size that approaches the minimum size reduction capability (76-100mm) of common agricultural equipment and still handle the substrate in a large square bale format. The square baled format allows for enhanced efficiencies in transportation and storage relative to the common round bale (Hickman 2015).

4.3 Materials and Methods

4.3.1 Substrate

The substrates used for this work were corn stover and switchgrass. The corn stover was Becks 6175 hybrid, harvested in the fall of 2013 at the C. Oran Little Research Center in Woodford County, KY. The Alamo switchgrass was harvested in February 2014 at the North Farm in Fayette County, KY. Both substrates were baled and stored in barns and moved to the lab for use as needed. The materials were air dried in the lab to a moisture content of about 8.5% w.b.. For the nominal 5mm particle size experiments, the feedstock was ground to pass a 5mm screen in a C.S. Bell No. 10 hammer mill, and stored in standard plastic feed sacks until use. For the switchgrass used in the nominal 76mm particle size tests, the whole plant was cut to length with shears, placed in a container and mixed before use to approximate a representative sample of the whole plant. The stored moisture content varied seasonally but held within a range of 7% to 9% w.b. Moisture content was measured with an Ohaus MB35 Halogen moisture analyzer. The substrates were not sterilized before pretreatment.

4.3.2 Feedstock Composition

The composition of the lignocellulosic feedstocks used in this work was not analyzed. The difficulty in obtaining a true representative biomass sample coupled with variability of results produced by the oft used protocol NREL/TP-510-42618, Determination of Structural Carbohydrates and Lignin In Biomass, prompted the use of average composition values in all calculations as a way to reduce error introduced from compositional analysis. The work by the North Central Center provided the average values of biomass composition used in this work – primarily the mean cellulose content for corn stover and switchgrass (SunGrant 2007). This work used 37.5 % (w/w) cellulose content as the basis for all calculations for both feedstocks. The use of an average value does not negatively impact this work since all the comparisons examined relative performance instead of absolute values.

4.3.3 Pretreatment & Enzymatic Hydrolysis Vessel

The treatment vessel was designed as an up-flow reactor that would hold approximately 39 grams of raw substrate dry matter as shown in figure 7. The up-flow configuration was used to better eliminate all air from the vessel and ensure all pore space was filled. The vessel was a one pint canning jar, McMaster-Carr part # 3231T43, with standard tin bands and lids. The center of the jar bottom was drilled to accept a removable hose connection, Chemglass part # CG-1563-01, which connected to the supply side of the pump; a hole was punched in the replaceable lid to accept a bulkhead fitting, McMaster-Carr part # 5463K83, to connect the return flow line. Stainless steel wire mesh screens were used in the vessel above and below the feedstock to prevent solids from leaving the vessel and to inhibit the development of preferential flow paths through the feedstock; the screens were 20 mesh, 0.16" wire diameter, McMaster-Carr part# 9317T81. The vessels were loaded by placing a screen on the bottom of the vessel and then taring on a balance, loading with each vessel with a total mass calculated to yield 38 - 39 grams of substrate dry matter, and then capped with a screen before installing the lid and band as shown in figure 7.



Figure 8: Up-flow Treatment Vessel left; Vessel with 38 gDM right

4.3.4 *Recirculating Lime Solution Pretreatment*

The calcium hydroxide (CAS No. 1305-62-0) used for all experiments was Acros Organics catalog number 21918, lot number A0323480. The lime was loaded at 10% w/w for the total mass of dry matter. The lime was weighed out, added to about one liter of water, agitated and then pumped into the filter. Once all the lime solids were in the filter, the reservoir recirculation process began to ensure the reservoir contained a saturated solution; pretreatment recirculation immediately followed the addition of lime to the filter. This process was followed for all recirculating pretreatment runs. The pretreatment process was run for 7 days at ambient laboratory temperature of 22°C. Once the pretreatment period elapsed, the recirculation pump drives were reversed and the lime solution was pumped out of the treatment vessels to remain in the reservoir and reuse for the next pretreatment run. Six treatment vessels were placed on an elevated platform for each experimental run for pretreatment at ambient temperatures as shown in

figure 8. The six vessel configuration allowed for a group of six or two groups of three for side by side comparisons.



Figure 9: Experiment Pretreatment System

4.3.5 *Post Pretreatment Solids Conditioning*

At the completion of pretreatment, the lime solution was pumped off and the solids allowed to gravity drain. No additional substrate conditioning was done before moving to hydrolysis.

4.3.6 *Enzymatic Hydrolysis Controls*

Bulk in-situ enzymatic hydrolysis was done with an effective insoluble solids content that initially matched pretreatment – between 14-16% (w/w) – a solids content that is more than 5 times higher than the standard NREL protocol at 2.7%(w/w). An experiment was conducted to assess the impact of high solids on NREL enzymatic saccharification of 5mm switchgrass. The switchgrass was tested at 2.7% (0.1g cellulose), 5.3% (0.2g cellulose), 10.7% (0.4g cellulose), and 16.0% (0.6g cellulose) dry matter solids and

cellulose content respectively with three replicates at each level following the NREL protocol. A commercial liquid cellulase enzyme - Novozyme CTec2, lot no. VCS00002 - was loaded at the manufacturer recommended dosage of 30% w/w of cellulose. CTec2 has been reported to have between 80 FPU/mL (Xu 2009) and 120 FPU/mL (Vivekanand, Olsen et al. 2014). Using a measured density of 1.17g/mL, a 30% (w/w) loading rate would translate to a loading rate in the range of 20-30 FPU per gram cellulose. The enzyme loading was adjusted based on cellulose content while the total hydrolysis volume was held constant.

After 72 hours in a shaking incubator at 50 °C, the enzymatic hydrolysis process was stopped by placing the samples in a 93 °C water bath for 15 minutes to denature the enzyme protein. The samples for the switchgrass replicates at 10.7% and 16% total solids were diluted with an additional 10mL of buffer solution in order to have sufficient sample volume for analysis. The samples were cooled on the bench, vortexed for 5-10 seconds and 1.5mL decanted into a labeled micro-centrifuge tube. The 1.5 mL samples were then centrifuged at 5,000 RPM for 10 minutes. Post centrifugation samples were moved directly to glucose measurement on an YSI 2900 biochemistry analyzer.

Standard NREL protocol (appendix B) enzymatic hydrolysis results served as the yield goal for bulk enzymatic hydrolysis of 5 mm substrate. The substrate for the standard hydrolysis was taken from the pretreatment vessels before moving to bulk hydrolysis. An approximately equal portion was removed from the upper third of each vessel comprising a group and the total wet weight recorded. The moisture content was determined and the dry matter removed from the vessel group was calculated. The total dry matter remaining in the group of vessels served as the basis for bulk hydrolysis yield calculations. The typical mass of dry matter removed from a group was 4-5 grams.

The performance benchmark for the bulk hydrolysis of 76mm substrate was the NREL protocol proportionally scaled by a factor of 10 and carried out in 500 mL Erlenmeyer flask to accommodate substrate length, ensure consistent solids contents, and thorough agitation from the shaking table. The procedure for obtaining pretreated 76mm substrate for the flask hydrolysis was the same as the 5mm substrate except that the substrate was largely vertically oriented in the vessel as shown in figure 9. This vertical

orientation of the substrate mimics that of a large square bale on edge in an on-farm bunker.



Figure 10: 76mm Switchgrass during Pretreatment

4.3.7 *In-Situ Bulk Enzymatic Hydrolysis*

Following completion of pretreatment and removal of the lime solution, the vessels were moved to a New Brunswick Scientific C76 water bath with digital temperature control for enzymatic hydrolysis as shown in figure 10. The same pumps and tubing used for pretreatment were relocated to serve in bulk hydrolysis; the tubing was completely drained of lime solution.

NREL Protocol NREL/TP-510-42629 served as the basis for the hydrolysis, with the ingredients proportionally scaled to serve in a bulk format. The 0.1M sodium citrate buffer solution was prepared in bulk at the desired pH, the non-enzyme ingredients added and mixed. One liter of buffer was then added to each reservoir which served three vessels as shown in figure 10. The pumps were started and additional buffer added to bring the reservoir volume back to one liter after filling the vessels and tubing; the total buffer volume was recorded. After filling the system, the buffer reservoirs were covered with parafilm wrap to inhibit evaporation.

The water bath was filled with hot tap water and brought to the operating temperature of 50 °C. The buffer solution was circulated for about one hour to bring the substrate and buffer solution to operating temperature before adding the cellulase enzyme Novozyme CTec2 at the manufacturer recommended dosage of 30% (w/w) of cellulose in the raw substrate.



Figure 11: Experimental Bulk Enzymatic Hydrolysis System

The pump drives were operated at about 50 rpm, delivering about 140 mL/min to each vessel, resulting in a vessel volume turnover rate of 42 times per hour flow during hydrolysis. The enzymatic hydrolysis proceeded for 72 hours after the addition of the enzyme. At the end of hydrolysis the pumps were set at maximum flow of about 280 mL/min for about two minutes to flush the vessels and agitate the reservoir. The pumps were then reversed and the enzyme solution pumped back to the reservoir for sampling. Three 1.5mL samples were immediately taken from each reservoir and centrifuged at 5,000 RPM for 10 minutes. The post centrifugation, unmodified hydrolysis samples were moved directly to glucose measurement on an YSI 2900 biochemistry analyzer.

4.3.8 *Glucose Contributions from Enzyme Addition*

The Novozyme commercial cellulase used contains glucose that must be accounted for to accurately quantify the glucose yield from the substrate. With NREL enzymatic hydrolysis, the enzyme blanks are easily created by not adding substrate to the test tube. However, the use of the reservoir in the bulk hydrolysis system complicates

quantification since the concentration of glucose in the reservoir immediately following enzyme addition represents only a portion of the total system volume and would result in higher concentrations than actual. Any samples pulled from the reservoir after enzyme addition and thorough circulation through the treatment vessels can be expected to contain glucose contributions from the substrate. To determine the enzyme contribution to glucose, five grams of enzyme solution was added to 10mL of buffer solution, and then additional buffer added to bring the total volume to 50mL. After thorough mixing, four 1.5mL samples were taken and analyzed on the YSI to quantify the glucose concentration of the solution. The mean value of gram glucose per gram enzyme was then used as the basis to determine the glucose contribution from enzyme addition to the full system.

4.3.9 Sample Saccharification Analysis

The YSI 2900D biochemistry analyzer used YSI membrane part # 2365 for glucose measurement. The instrument was calibrated before each analysis event with YSI part # 2776, 2.5 g/L glucose, resulting in an analysis range of 0.05-25 g/L glucose. After calibration, the measurement linearity was confirmed using YSI part #1531 glucose standard at 9.0 g/L. The samples to be analyzed were placed in a 24 well tray in a pre-determined random order to ensure any instrument drift was randomized. Four 9.0 g/L standards and two DI water standards were included as a quality control measure with each group of samples analyzed.

4.4 Statistics

The data were compiled in a spreadsheet with appropriate sample notation. The data were imported into and analyzed in SAS version 9.4 using a PROC GLM model and MEANS (LSD) tests. The dependent variable was the yield in grams glucose per gram dry matter (gG/gDM). The independent variables included substrate type, pretreatment chemical, chemical loading rate, pretreatment condition (recirculation or static), sample conditioning post-pretreatment, hydrolysis pH, and treatment date. The SAS model was used to identify insignificant independent variables for removal from the model.

4.5 Results and Discussion

4.5.1 High Solids Impact

The results of the experiment testing the impact of increasing insoluble solids loading on the standard NREL enzymatic hydrolysis of lime pretreated 5mm switchgrass are shown in figure 11. The results illustrate the general linear trend of decreasing glucose yields found with increasing insoluble solids concentrations when no attempts at optimization are made.

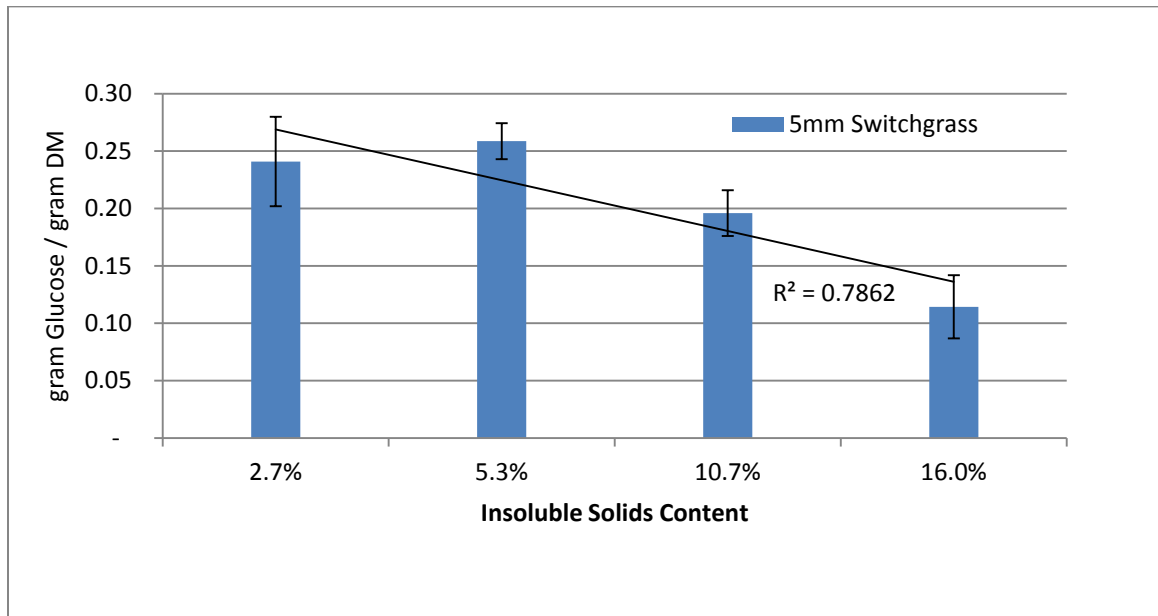

Figure 12: High Solids Effect on mean glucose yields in NREL hydrolysis. Error is standard deviation.

The impacts from a lack of free water became visually evident at 10.7% and 16% levels while preparing the samples for hydrolysis – impaired diffusion of enzyme solution was noted as was increased void space in the substrate due to substrate adhesion to the test tube walls; these tubes required tapping on the bottom in order to consolidate the substrate. During hydrolysis, visual observation showed that the mixing process was negatively impacted from the increased viscosity common to high solids loadings. As seen in figure 11, the yields show little impact up to the 5.3% (w/w) solids loading level. The yields at 10.7% (w/w) and 16% (w/w) represent only 78% and 46% respectively of the average yield of 0.25 gG/gDM produced at the low solids level. The cause(s) of the

yield reductions were not specifically investigated in this work, but were not unexpected based on the literature; yield reductions commonly found in high solids operations have been attributed to increased system viscosity and poor mixing, impeded diffusion by the lack of free water, and product inhibition of the enzyme system. The recirculating enzyme solution should improve the issues associated with mixing and free water availability in a high solids environment.

4.5.2 *In-situ Bulk Enzymatic Hydrolysis Yields*

Both corn stover and switchgrass substrates were tested; corn stover at 5mm particle size and switchgrass at 5mm and 76 mm sizes. The 76mm particle length represents the lower limit of cut length for baling equipment with secondary crop processing capabilities and the maximum length of the treatment vessel.

4.5.2.1 *5mm Corn Stover Yield Comparisons*

Results from SAS 9.4 MEANS (LSD) tests with an alpha value of 0.05 were used to construct figure 12 below.

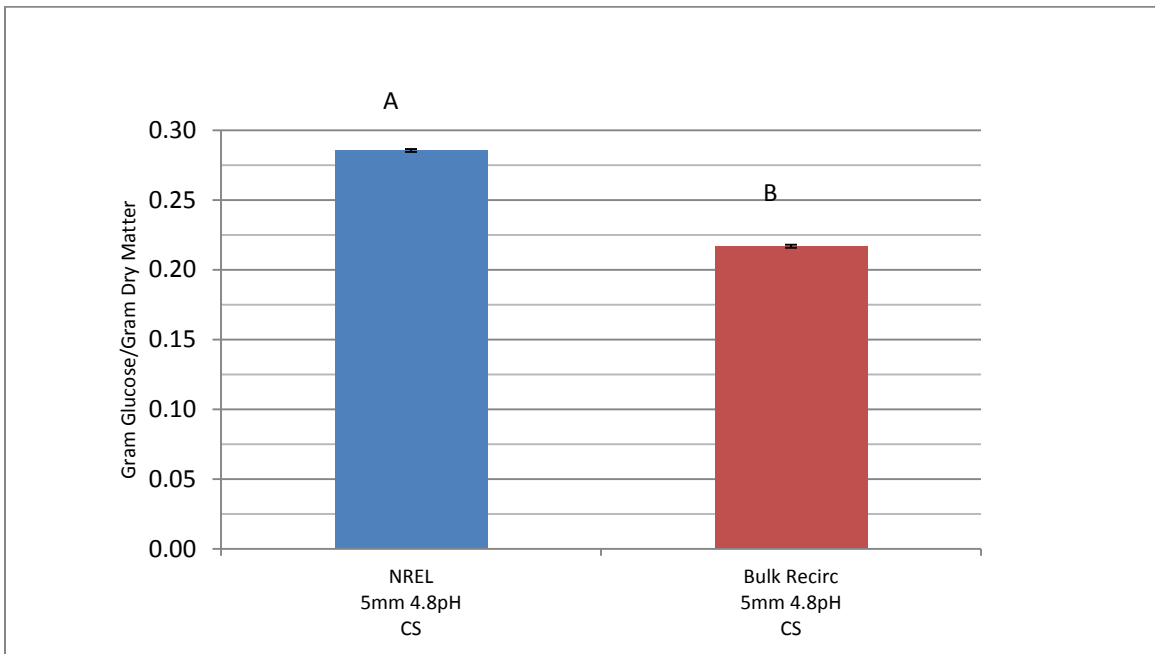

Figure 13: Hydrolysis Method Comparison of 5mm Corn Stover. Error is MSE. Means with the same letter are not significantly different.

Figure 12 shows that the NREL hydrolysis method, starting at 2.7% (w/w) insoluble solids content, produced a significantly higher mean glucose yield than the in-situ recirculating bulk hydrolysis method with an initial solids content of 14-16% (w/w). The bulk method produced a mean yield that was 76% of the mean NREL glucose yield. If the trend shown in figure 11 is consistent across herbaceous lignocellulosic substrates as expected, the recirculation system produced a mean yield greater than would be expected with an unmodified NREL hydrolysis. In addition to a yield advantage for high solids hydrolysis, the recirculation approach consumes no energy for substrate mixing, which would not be possible in an on-farm bunker filled with baled substrate. While the pumping system would consume energy, the flow resistance will drop over time due to the decreasing solids content from cellulose solubilization, thus decreasing pump power requirements. Figure 13 illustrates the dry matter loss and volumetric reduction from in-situ bulk enzymatic hydrolysis of 5mm corn stover.



Figure 14: Pre & Post Enzymatic Hydrolysis of 5mm Corn Stover

4.5.2.2 5mm Switchgrass Yield Comparisons

Results from SAS 9.4 MEANS (LSD) tests with an alpha value of 0.05 were used to construct figure 14 below.

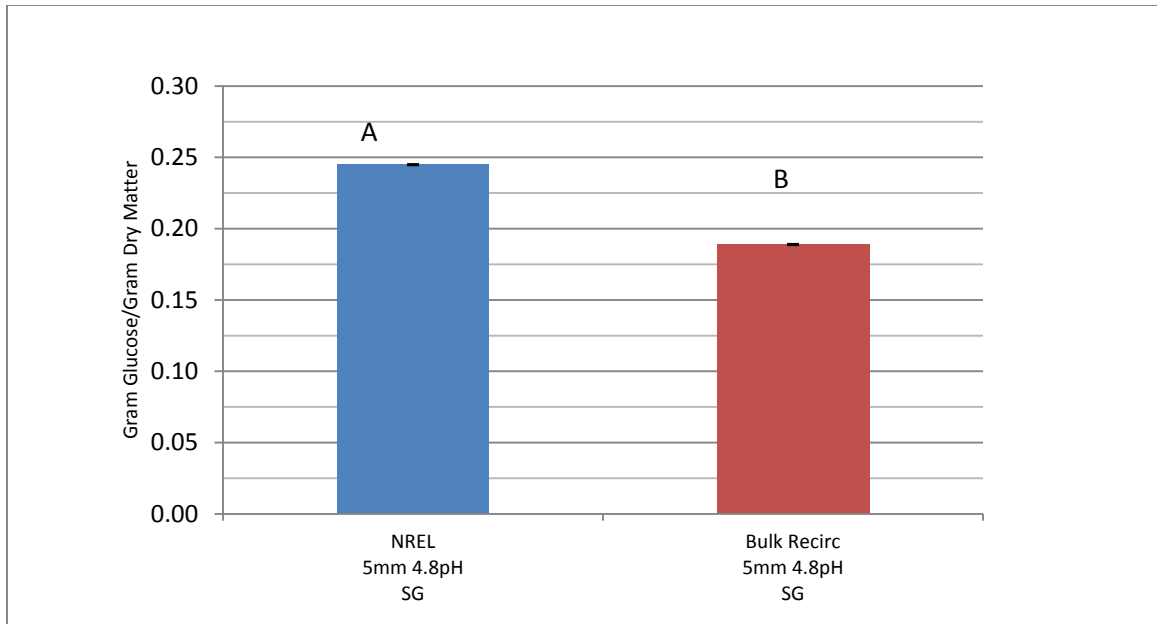

Figure 15: Hydrolysis Method Comparison of 5mm Switchgrass. Error is MSE. Means with the same letter are not significantly different.

Figure 14 shows that the NREL hydrolysis method again produced a significantly higher mean glucose yield than the bulk method; the bulk method again produced a mean glucose yield that was 77% of the mean NREL glucose yield. The mean glucose yield for 5 mm switchgrass at 16% (w/w) solids loading from figure 11 is 0.11 gG/gDM, whereas the yield from figure 14 bulk hydrolysis is 0.19 gG/gDM – a 73% increase in yield attributable to the recirculating approach to enzymatic hydrolysis in a high solids system.

4.5.2.3 5mm & 76mm Switchgrass Yield Comparisons

Results from SAS 9.4 MEANS(LSD) tests with an alpha value of 0.05 were used to construct figure 15 below.

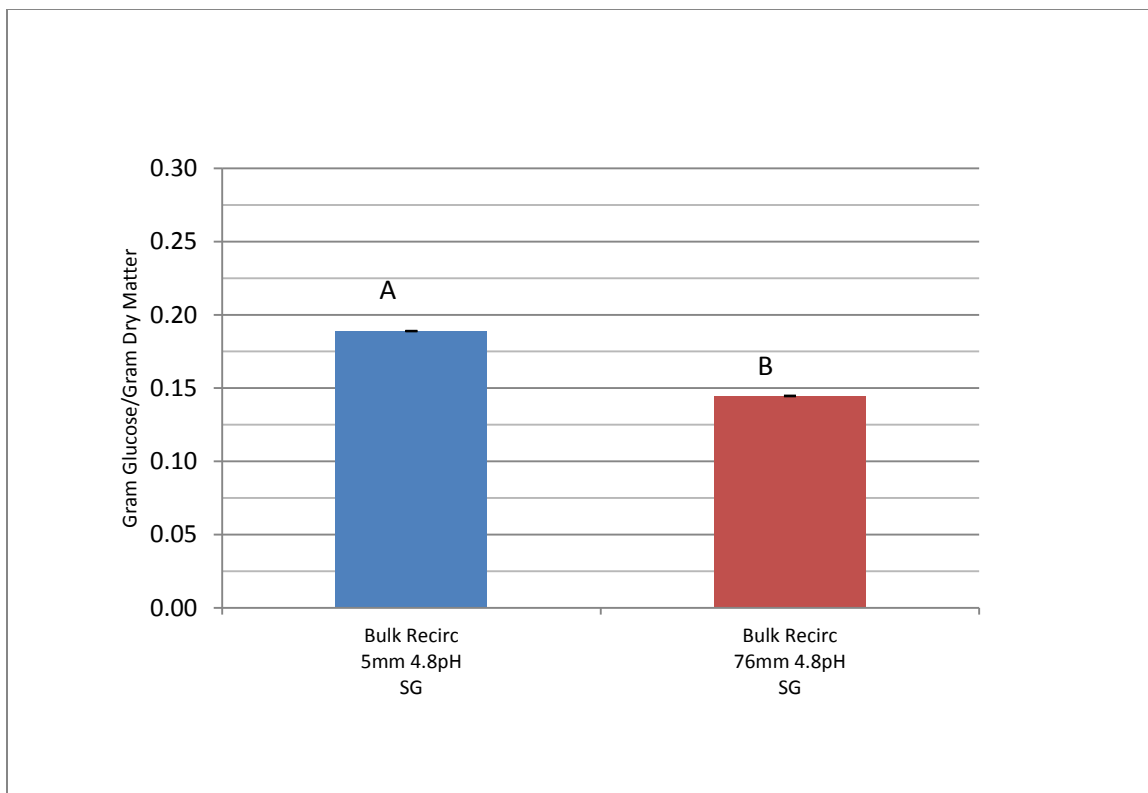

Figure 16: Switchgrass Particle Size Impact on Mean Glucose Yields. Error is MSE. Means with the same letter are not significantly different.

The glucose yields in figure 15 shows the negative impact of increasing the particle size – the only known difference in the substrate – which led to a significantly lower mean glucose yield. The mean glucose yield for 5 mm switchgrass at 16% (w/w) solids loading from figure 15 is 0.189 gG/gDM, whereas the mean yield for 76mm under the same conditions is 0.145 gG/gDM – about a 77% yield ratio.

A control experiment was done to try to separate the impact of the high solids bulk hydrolysis from the larger particle size. Figure 16 below shows the results from SAS 9.4 MEANS (LSD) tests with an alpha value of 0.05 on the mean glucose yields for the bulk hydrolysis and the low solids NREL hydrolysis proportionally scaled up to accommodate the larger particle size.

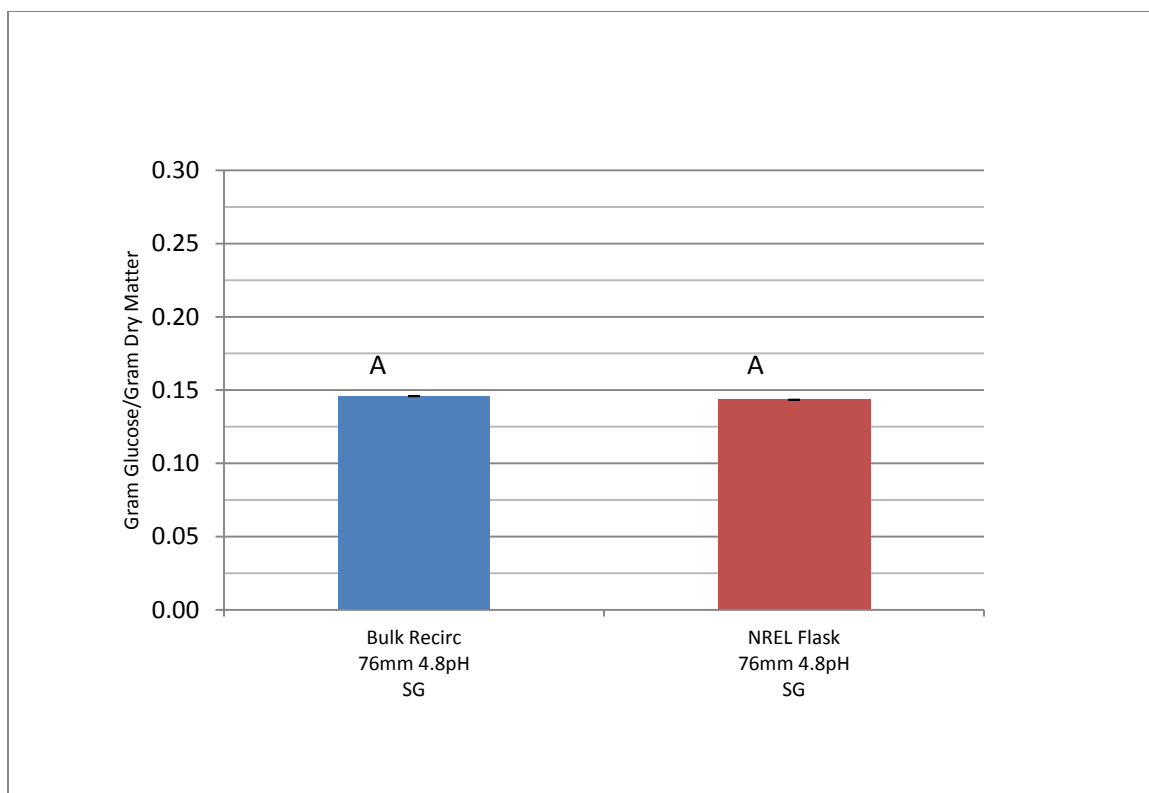

Figure 17: Hydrolysis Method Comparison of 76mm Switchgrass. Error is MSE. Means with the same letter are not significantly different.

The lack of a significant difference between the two enzymatic hydrolysis methods shown in figure 16 confirms that the particle size has more impact on glucose yields than the initial insoluble solids loading for each method in this work.

4.6 Conclusion

The effect of increasing the insoluble solids loading shown in figure 11 confirms a general trend found in our laboratory and throughout the literature of decreasing glucose yields with increased initial solids loading. However, the bulk recirculating approach produced mean glucose yields from 5mm switchgrass that were about 70% greater (0.19 to 0.11 gG/gDM) than the mean yield shown in figure 11 at the 16% (w/w) initial solids loading. The specific cause(s) for the improvements were not investigated; however one may reasonably expect that the recirculating enzyme solution ameliorated issues associated with the commonly identified lack of free water, poor mixing, and enzymatic inhibition by product accumulation.

In-situ recirculating bulk enzymatic hydrolysis produced a mean glucose yield that achieves 76-77% of the yields produced by low solids NREL hydrolysis of the same lime pretreated 5mm substrate. The reason(s) for the reduced mean yields were not specifically investigated.

The effects of particle size shown in figure 15 highlight the improvements to lignocellulosic digestibility possible from size reduction. The fact that there was no significant difference in figure 16 suggests that particle size was a greater limitation to glucose yields than the hydrolysis method. Nature offers clues about the digestion of lignocellulose – ruminant animals reduce the particle size by chewing the substrate multiple times reducing particle size; economy suggests that a larger particle size is preferable. Successful implementation of high solids in-situ bulk enzymatic hydrolysis requires that a balance be struck between particle size, severity of pretreatment, and the resulting glucose yields.

CHAPTER 5: OVERALL CONCLUSIONS & FUTURE WORK

5.1 Overall Conclusions

Among the commonly available hydroxide species, lime seems to have a reputation as a less effective lignocellulosic pretreatment chemical. One underlying issue with effectiveness as compared with other hydroxide species revolves around its poor solubility in water. The pretreatment paradigm of adding the chemical solids and water to substrate within a treatment vessel are pervasive throughout the literature reviewed. This method paradigm does nothing to accommodate lime's limited solubility but rather works against it. The paradigm has likely spawned other practices that attempt to improve lime pretreatment effectiveness – high temperatures, oxidative environments, extended pretreatment periods, adding other chemicals, et al. The resulting recommendations are typically energy, resource, and/or time intensive yet still produce results that are comparable with more soluble hydroxide species. While bulk lime costs about 1/3 of sodium hydroxide, the implementation costs for intensive practices could be considered to eliminate a sizable portion lime's cost advantage. Further, intensive practices limit process implementation to a more industrialized setting.

This work presents the novel idea of recirculating a filtered, saturated lime solution through the substrate in an up-flow, high solids (14-16% w/w) configuration at ambient conditions. In this system, lime solids were efficiently consumed, post-pretreatment washing of substrate did not significantly improve glucose yields, and energy and resources were conserved. The pretreatment effectiveness of lime was assessed by comparing glucose yields with NaOH results as well as relevant literature values. The yield results shown in this work compare extremely well to the literature. Relative to NaOH, the grand mean glucose yields across substrates and comparisons result in lime pretreated substrate producing about 81% of NaOH pretreated substrate. However, this single performance metric fails to adequately illustrate the economic value and practicality of this approach.

A very different perspective emerges by using the mean glucose yields from corn stover for both lime and NaOH pretreatment, 0.29gG/gDM and 0.34gG/gDM respectively, to compare relative costs instead of gross yields. Considering only the bulk chemical cost to produce 100kgs of glucose, lime costs \$8.67 and requires ~350kgs of

stover dry matter, while NaOH costs \$22.38 and requires ~300kg of stover dry matter. Additionally, the cost avoidance and environmental value of not washing solids combined with potentially simple calcium recovery and disposal of exhausted lime solution result in lime being a much preferred pretreatment chemical to implement in an on-farm scenario.

Representing a paradigm shift in high solids enzymatic hydrolysis, the same up-flow recirculating configuration was then used to enzymatically hydrolyze the pretreated 5mm substrate in-situ with an initial high solids loading of 14-16% (w/w). The recirculating system produced mean glucose yields ~70% greater than an NREL hydrolysis modified to a 16% (w/w) initial solids loading, while achieving ~77% of the glucose yield of an unmodified NREL enzymatic hydrolysis at 2.7% (w/w) solids.

The recirculating approach to both lignocellulose pretreatment and subsequent enzymatic hydrolysis offers the opportunity to implement biomass conversion in a simple, practical system on-farm, focused on resource conservation while producing relevant yields.

5.2 Recirculating Lime Solution Pretreatment Optimization

5.2.1 Recirculation Flow Rate

The flow rate used in this work was a practical choice based on the equipment available along with the intent to avoid any limitation from insufficient hydroxyl ion availability. However, the flow rate of about 140mL/min to each vessel results in 3.6mL/min/gDM, that when scaled to a 100 ton bunker results in a flow of 87,000 gallons per minute. Such a flow rate is impractical when considered in terms of infrastructure requirements, energy consumption, and economics. In order to minimize the system flow rate without impacting glucose yields, experiments could be done testing lower flow rates to identify a minimum or at least bracket it. However, it may be possible to estimate hydroxyl ion consumption and generation rates during pretreatment and use that information to bracket an optimal flow rate. A work by Kim and Holtzaple on the delignification of corn stover could be a starting point in the literature (Kim and Holtzaple 2005).

5.2.2 Pretreatment Time Period

The time period used in this work was a practical choice based on laboratory schedules as well as typical literature values. The results of some early experiments (data not shown) that were allowed to continue for up to 8 weeks showed no noticeable improvement in glucose yields over the 7 day pretreatment period. Experiments could be done to examine periods less than 7 days in the interest of reduced energy consumption and a higher material throughput in an on-farm system. A potential starting point in the literature could be work done by Xu and Cheng, which showed that a 4 day pretreatment produced higher yields than a 7 day (Xu, Cheng et al. 2010).

5.2.3 Lime Solution Reuse

The recirculating lime solution with filtration proved to be an effective way to provide a continuously saturated lime solution to pretreat substrate while eliminating solid lime from the substrate. The solution was reused and additional lime solids added to the system without apparent negative impact to glucose yields. While no problems with calcium carbonate scaling were observed in this work, the reality of complex water chemistry and the buildup of calcium ions suggest that the potential for problems with calcium carbonate scaling should be explored before pilot scale implementation takes place.

5.2.4 Initial Solids Loading Increase

The recirculating solution was shown to produce yields commensurate with other, more harsh, lime pretreatments that were done with lower solids loadings. The ability to increase the initial solids loading beyond that tested in this work could provide economy to any future on-farm system. A 20% (w/w) solids loading is likely the practical limit given the saturated condition of the substrate, and limitations on increasing the bulk density within the vessel. The geometry and configuration could be altered to reduce void space and allow for substrate compression (baling) before pretreatment. These changes could result in a minimized non-effective volume of solution in the treatment vessel.

5.2.5 *Substrate Particle Size*

The choice to test the 76mm particle sizes represent a practical limitation of the height of the treatment vessel and as the lower limit of secondary processing during the substrate baling process. Additional testing should be done to examine particle sizes between those tested in this work to understand if there is a linear decrease in glucose yields similar to that found with solids loading and NREL tube hydrolysis.

5.2.6 *Lignin-Calcium-Lignin & Calcium-Carbohydrate Bonding*

The general opinion within the biomass processing field is that lignin reduction is a valuable measure of pretreatment effectiveness. The literature that has used lime pretreatment has generally shown a lower lignin reduction than other alkali pretreatments such as sodium and potassium hydroxides, and sometimes reporting comparable glucose yields (Xu, Cheng et al. 2010; Soares Rodrigues 2015). A possible explanation for this lignin reduction difference involves lignin calcium bonds. The literature has examples documenting that divalent calcium ions will complex with lignin, leading to lignin aggregation, retention, and potential precipitation in a base environment, hence resulting in a higher lignin content of the pretreated materials. The opinion that divalent calcium ions complex with carbohydrates thus limiting carbohydrate degradation and loss, as well as reducing non-productive enzyme binding exists within the literature as well. With additional study, these phenomena could potentially be exploited in lime biomass pretreatment and subsequent enzymatic hydrolysis for process improvement (Torre, Rodriguez et al. 1992; Sundin 2000; Liu, Zhu et al. 2010; Xu, Cheng et al. 2010; Wang and Cheng 2011; Yan, Li et al. 2015).

5.3 Recirculating Cellulase Enzyme Solution Optimization

5.3.1 *Bulk Enzymatic Hydrolysis Flow Rate*

This work used approximately the same flow rates for both pretreatment and in-situ bulk enzymatic hydrolysis based on available equipment as well as a lack of information in the literature. The literature examined suggests that the enzyme kinetics, association and disassociation occur on time scales that would not likely be impacted by a 0.50 mm/sec superficial fluid velocity through the substrate (Cruys-Bagger, Elmerdahl et al. 2012). However work on the impact to cellulase enzymes from shear stress, turbulence,

et al from flowing fluid was not found. Higher flow rates were rejected because of the limitations on heat transfer – too high and the temperature of the return fluid stream was below 50°C. Lower flow rates tended to overheat the pump motors. The minimization of the flow rate would be a desirable improvement in an on-farm scenario.

5.3.2 Enzyme Dosage & Timing

This work used the recommended dosage of 30% (w/w) of Novozyme CTec2 cellulase as suggested, but the guidance notes that it may not be economically viable in a large scale system. Additional work could be done to identify an enzyme dosage / yield response curve for this system to help identify an economically viable quantity. In addition, this work added the cellulase enzyme to the bulk system reservoir at one time. There is work suggesting that a proportional dosing of the total quantity of enzyme be done over some time period could enhance yields. A potential starting point in the literature could be the work by Modenbach and Nokes (Modenbach and Nokes 2013).

5.3.3 Hydrolysis Time Period & Temperature

The bulk enzymatic hydrolysis was run for 72hrs at 50°C to allow comparison with the low solids test tube NREL hydrolysis results. However, there may be value in reducing the temperature and extending the hydrolysis time period as a way to increase hydrolysis yields. A potential starting point in the literature could be the work by Modenbach and Nokes (Modenbach and Nokes 2013) as well as the Novozyme guidance document (Novozyme 2010).

APPENDICES

Appendix A. Experimental Data

trt	remark	size	hyd	pH	day	sub	chem	cond	rep	yield
3	wa	5mm	tube	4.8	1023	cs	caoh	R	1	0.271
3	wa	5mm	tube	4.8	1023	cs	caoh	R	2	0.297
3	wa	5mm	tube	4.8	1023	cs	caoh	R	3	0.312
4	un	5mm	tube	4.8	1120	cs	caoh	R	1	0.272
4	un	5mm	tube	4.8	1120	cs	caoh	R	2	0.254
4	un	5mm	tube	4.8	1120	cs	caoh	R	3	0.271
5	un	5mm	tube	4.8	1120	cs	caoh	R	1	0.308
5	un	5mm	tube	4.8	1120	cs	caoh	R	2	0.317
5	un	5mm	tube	4.8	1120	cs	caoh	R	3	0.311
6	un	5mm	tube	5.5	1120	cs	caoh	R	1	0.267
6	un	5mm	tube	5.5	1120	cs	caoh	R	2	0.283
6	un	5mm	tube	5.5	1120	cs	caoh	R	3	0.279
7	un	5mm	tube	5.5	1120	cs	caoh	R	1	0.278
7	un	5mm	tube	5.5	1120	cs	caoh	R	2	0.298
7	un	5mm	tube	5.5	1120	cs	caoh	R	3	0.316
8	wa	5mm	tube	4.8	1217	cs	naoh	S	1	0.279
8	wa	5mm	tube	4.8	1217	cs	naoh	S	2	0.346
8	wa	5mm	tube	4.8	1217	cs	naoh	S	3	0.380
10	wa	5mm	tube	5.5	1217	cs	naoh	S	1	0.304
10	wa	5mm	tube	5.5	1217	cs	naoh	S	2	0.331
10	wa	5mm	tube	5.5	1217	cs	naoh	S	3	0.367
13	un	5mm	tube	4.8	122	cs	caoh	R	1	0.321
13	un	5mm	tube	4.8	122	cs	caoh	R	2	0.313
13	un	5mm	tube	4.8	122	cs	caoh	R	3	0.310
15	un	5mm	tube	5.5	122	cs	caoh	R	1	0.307
15	un	5mm	tube	5.5	122	cs	caoh	R	2	0.317
15	un	5mm	tube	5.5	122	cs	caoh	R	3	0.305
17	un	5mm	tube	4.8	216	cs	caoh	R	1	0.230
17	un	5mm	tube	4.8	216	cs	caoh	R	2	0.236
17	un	5mm	tube	4.8	216	cs	caoh	R	3	0.262
19	un	5mm	tube	5.5	216	cs	caoh	R	1	0.186
19	un	5mm	tube	5.5	216	cs	caoh	R	2	0.203
19	un	5mm	tube	5.5	216	cs	caoh	R	3	0.215
1	wa	5mm	tube	4.8	1023	sg	caoh	R	1	0.244
1	wa	5mm	tube	4.8	1023	sg	caoh	R	2	0.255
1	wa	5mm	tube	4.8	1023	sg	caoh	R	3	0.250
2	un	5mm	tube	4.8	1023	sg	caoh	R	1	0.221
2	un	5mm	tube	4.8	1023	sg	caoh	R	2	0.228
2	un	5mm	tube	4.8	1023	sg	caoh	R	3	0.235
9	wa	5mm	tube	4.8	1217	sg	naoh	S	1	0.304
9	wa	5mm	tube	4.8	1217	sg	naoh	S	2	0.321
9	wa	5mm	tube	4.8	1217	sg	naoh	S	3	0.253
11	wa	5mm	tube	5.5	1217	sg	naoh	S	1	0.312
11	wa	5mm	tube	5.5	1217	sg	naoh	S	2	0.294

11	wa	5mm	tube	5.5	1217	sg	naoh	S	3	0.272
12	un	5mm	tube	4.8	122	sg	caoh	R	1	0.253
12	un	5mm	tube	4.8	122	sg	caoh	R	2	0.273
12	un	5mm	tube	4.8	122	sg	caoh	R	3	0.286
14	un	5mm	tube	5.5	122	sg	caoh	R	1	0.285
14	un	5mm	tube	5.5	122	sg	caoh	R	2	0.273
14	un	5mm	tube	5.5	122	sg	caoh	R	3	0.268
16	un	5mm	tube	4.8	216	sg	caoh	R	1	0.230
16	un	5mm	tube	4.8	216	sg	caoh	R	2	0.237
16	un	5mm	tube	4.8	216	sg	caoh	R	3	0.226
18	un	5mm	tube	5.5	216	sg	caoh	R	1	0.205
18	un	5mm	tube	5.5	216	sg	caoh	R	2	0.228
18	un	5mm	tube	5.5	216	sg	caoh	R	3	0.198
20	un	5mm	bulk	5.5	1120	sg	caoh	R	1	0.143
20	un	5mm	bulk	5.5	1120	sg	caoh	R	2	0.139
20	un	5mm	bulk	5.5	1120	sg	caoh	R	3	0.138
20	un	5mm	bulk	5.5	1120	sg	caoh	R	4	0.138
20	un	5mm	bulk	5.5	1120	sg	caoh	R	5	0.138
20	un	5mm	bulk	5.5	1120	sg	caoh	R	6	0.138
21	un	76mm	bulk	5.5	1204	sg	caoh	R	1	0.126
21	un	76mm	bulk	5.5	1204	sg	caoh	R	2	0.125
21	un	76mm	bulk	5.5	1204	sg	caoh	R	3	0.123
21	un	76mm	bulk	5.5	1204	sg	caoh	R	4	0.134
21	un	76mm	bulk	5.5	1204	sg	caoh	R	5	0.134
21	un	76mm	bulk	5.5	1204	sg	caoh	R	6	0.134
22	un	76mm	bulk	4.8	1218	sg	caoh	R	1	0.147
22	un	76mm	bulk	4.8	1218	sg	caoh	R	2	0.148
22	un	76mm	bulk	4.8	1218	sg	caoh	R	3	0.147
22	un	76mm	bulk	4.8	1218	sg	caoh	R	4	0.146
22	un	76mm	bulk	4.8	1218	sg	caoh	R	5	0.146
22	un	76mm	bulk	4.8	1218	sg	caoh	R	6	0.143
23	un	5mm	bulk	4.8	122	cs	caoh	R	4	0.179
23	un	5mm	bulk	4.8	122	cs	caoh	R	5	0.186
23	un	5mm	bulk	4.8	122	cs	caoh	R	6	0.187
24	un	5mm	bulk	4.8	122	sg	caoh	R	1	0.174
24	un	5mm	bulk	4.8	122	sg	caoh	R	2	0.164
24	un	5mm	bulk	4.8	122	sg	caoh	R	3	0.165
25	un	76mm	bulk	4.8	125	sg	caoh	F	1	0.161
25	un	76mm	bulk	4.8	125	sg	caoh	F	2	0.147
25	un	76mm	bulk	4.8	125	sg	caoh	F	3	0.141
25	un	76mm	bulk	4.8	125	sg	caoh	F	4	0.113
25	un	76mm	bulk	4.8	125	sg	caoh	F	5	0.156
25	un	76mm	bulk	4.8	125	sg	caoh	F	6	0.142
26	un	5mm	bulk	4.8	216	cs	caoh	R	4	0.247
26	un	5mm	bulk	4.8	216	cs	caoh	R	5	0.249
26	un	5mm	bulk	4.8	216	cs	caoh	R	6	0.254
27	un	5mm	bulk	4.8	216	sg	caoh	R	1	0.206
27	un	5mm	bulk	4.8	216	sg	caoh	R	2	0.211
27	un	5mm	bulk	4.8	216	sg	caoh	R	3	0.213

Procedure Title: Enzymatic Saccharification of Lignocellulosic Biomass

Laboratory Analytical Procedure

1. Introduction

1.1 This procedure describes the enzymatic saccharification of cellulose from native or pretreated lignocellulosic biomass to glucose in order to determine the maximum extent of digestibility possible. A saturating level of a commercially available or in-house produced cellulase preparation and hydrolysis times up to one week are used.

2. Scope

2.1 This procedure is appropriate for lignocellulosic biomass. If the biomass is suspected to have some starch content, dry weight percent cellulose calculated from total glucan must be corrected to subtract the starch contribution to total dry weight percent glucose.

2.2 All analyses should be performed in accordance with an appropriate laboratory specific Quality Assurance Plan (QAP).

3. Terminology

3.1 *Pretreated biomass*: biomass that has been chemically or thermally altered, changing the structural composition

3.2 *Cellulase enzyme*: an enzyme preparation exhibiting all three synergistic cellulolytic activities: endo-1,4- β -D-glucanase, exo-1,4- β -glucosidase, and β -D-glucosidase activities, which are present to different extents in different cellulose preparations.

4. Significance and Use

4.1 The maximum extent of digestibility is used in conjunction with other assays to determine the appropriate enzyme loading for the saccharification of biomass.

4.2 This procedure can also be used to measure the efficacy of a given pretreatment based on a maximum enzyme loading.

5. Interferences

5.1 Test specimens not suitable for analysis by this procedure include acid- and alkaline- pretreated biomass samples that have not been washed. Unwashed pretreated biomass samples containing free acid or alkali may

change solution pH to values outside the range of enzymatic activity; and the unwashed glucose in the biomass may influence the final result.

- 5.2 Air drying of biomass samples prior to saccharification may have an impact on the maximal conversions achieved.

6. Apparatus and Materials

- 6.1 A suitable shaking or static incubator set at $50^{\circ} \pm 1^{\circ}\text{C}$
- 6.2 Any fixed speed rotator that can hold scintillation vials and operate in a static incubator.
- 6.3 Scintillation vial rack/tray
- 6.4 pH meter
- 6.5 Analytical balance, accurate to 1 mg or 0.1 mg
- 6.6 YSI analyzer with appropriate membranes or equivalent glucose quantification method such as HPLC
- 6.7 200 μL and a 1000 μL Eppendorf Pipetman pipet with tips
- 6.8 20-mL glass scintillation vials equipped with plastic-lined caps

7. Reagents

- 7.1 Reagents
 - 7.1.1 Tetracycline (10 mg/mL in 70% ethanol).
 - 7.1.2 Cycloheximide (10 mg/mL in distilled water).
 - 7.1.3 Alternate antibiotic – Sodium Azide (20 mg/ml in distilled water)
 - 7.1.4 Sodium citrate buffer (0.1M, pH 4.80).
 - 7.1.5 Cellulase enzyme of known activity, FPU/mL.
 - 7.1.6 Beta-glucosidase enzyme of known activity, pNPGU/mL
 - 7.1.7 (If necessary) Xylanase enzyme of known protein concentration, mg/ml

8. ES&H Considerations and Hazards

- 8.1 Cycloheximide, tetracycline and sodium azide are hazardous and must be handled with appropriate care.
- 8.2 Follow all applicable NREL chemical handling procedures

9. Sampling, Test Specimens and Test Units

None

10. Procedure

- 10.1 Perform LAP “Determination of Total Solids in Biomass” for all cellulose containing samples to be digested. Note: all lignocellulosic materials which have undergone some aqueous pretreatment must never be air-dried prior to enzyme digestibility, since irreversible pore collapse can occur in the micro-structure of the biomass leading to decreased enzymatic release of glucose from the cellulose.

- 10.2 Weigh out a biomass sample equal to the equivalent of 0.1 g of cellulose or 0.15 g total biomass on a 105°C dry weight basis (the cellulose content of the sample is initially determined as glucose by LAP- 002, minus the contribution of any starch present, LAP- 016) and add to a 20 mL glass scintillation vial.
- 10.3 To each vial, add 5.0 mL 0.1 M, pH 4.8 sodium citrate buffer. To each vial, add 40 µL (400 µg) tetracycline and 30 µL (300 µg) cycloheximide to prevent the growth of organisms during the digestion. Since tetracycline and cycloheximide both pose reproductive hazards, 100 µL of a 2% sodium azide solution may be added as an alternate to the tetracycline/cycloheximide combination (Note: do not combine sodium azide with the tetracycline/cycloheximide combination).
- 10.4 Calculate the amount of distilled water needed to bring the total volume in each vial to 10.00 mL after addition of the enzymes specified in the following step. Add the appropriate calculated volume of water to each vial. All solutions and the biomass are assumed to have a specific gravity of 1.000 g/mL. Thus, if 0.200 g of biomass is added to the vial, it is assumed to occupy 0.200 mL and 9.733 mL of liquid is to be added.
- 10.5 Bring the contents of each vial to 50°C by warming in the incubator set at 50° ± 1°C. To each vial is added an appropriate volume of the cellulase enzyme preparation to equal approximately 60 FPU/g cellulose and the appropriate volume of β-glucosidase enzyme to equal 64 pNPGU/g cellulose. Xylase may be added at the same time. Note: If the rate of enzymatic release of glucose is to be measured, all contents of the vial prior to the addition of the enzyme must be at 50°C. The enzymes are always added last since the reaction is initiated by the addition of enzyme.
- 10.6 Prepare a reaction blank for the substrate. The substrate blank contains buffer, water, and the identical amount of substrate in 10.00 mL volume.
- 10.7 Prepare enzyme blanks for cellulase, β-glucosidase, and xylanase with buffer, water, and the identical amount of the enzyme.

- 10.8 Close the vials tightly and place them in a scintillation vial rack suitable for the shaking incubator or fixed speed rotator that has been placed in the incubator. Set the temperature to 50°C and incubate with shaking or rotation sufficient to keep solids in constant suspension for a period of 72 to 168 hours or until the release of soluble sugars from the sample(s) becomes negligible when measured by YSI, as described in the next step.
- 10.9 If the progress of the reaction is to be measured, a 0.3-0.5 mL aliquot is removed at each predetermined time interval after the vial contents have been well mixed by shaking. Use a 1-mL plastic syringe to draw a representative sample while constantly suspending the contents of the vial. Alternatively, this is accomplished by using a 1.0-mL pipet with the tip of the plastic 1.0-mL tip slightly cut off (to allow solids, as well as liquid, to be withdrawn into the orifice). The sample is filtered through a 0.45 µm filter and subjected to glucose analysis using the YSI glucose analyzer or appropriate HPLC method.

11. Calculations

- 11.1 To calculate the percent digestibility of the cellulose added to the scintillation vial, determine glucose concentration in the centrifuged supernatant by YSI. Subtract the glucose concentrations, if any, from the substrates and enzyme blanks.
- 11.2 Correct for hydration (multiply the glucose reading by 0.9 to correct for the water molecule added upon hydrolysis of the cellulose polymer) and multiply by 10 mL total volume of assay.

Example: If the glucose analyzer reading (corrected with blanks) is 9.9 mg/mL, then the amount of cellulose digested is:

$$0.0099 \text{ g/mL} \times 10 \text{ mL} \times 0.9 = 0.0891 \text{ g}$$

- 11.3 Calculate percent digestion:

$$\% \text{ digestion} = \frac{\text{grams cellulose digested}}{\text{grams cellulose added}} \times 100$$

- 11.4 To report or calculate the relative percent difference (RPD) between two samples, use the following calculation:

$$RPD = \left(\frac{(X_1 - X_2)}{X_{mean}} \right) \times 100$$

Where:

X_1 and X_2 = measured values

X_{mean} = the mean of X_1 and X_2

11.5 To report or calculate the root mean square deviation (RMS deviation) or the standard deviation (st dev) of the samples, use the following calculations.

First find the root mean square (RMS), of the sample using

$$RMS = x_m = mean = \sqrt{\frac{\left(\sum_{i=1}^n x \right)^2}{n}}$$

Then find the root mean square deviation, or standard deviation, using

$$RMS\ deviation = \sigma = stdev = \sqrt{\frac{\sum_{i=1}^n (x_i - x_m)^2}{n}}$$

Where:

x_m =the root mean square of all x values in the set

n =number of samples in set

x_i =a measured value from the set

12. Report Format

12.1 Report the percent cellulose digested in the sample, to two decimal places, on a 105°C dry weight basis. Cite the basis used in the report.

12.2 For replicate analyses of the same sample, report the average, standard deviation, and relative percent difference (RPD).

13. Precision and Bias

13.1 The precision of this protocol has not been defined because it is dependent upon cellulase source and substrate composition. Not only will different preparations of cellulase hydrolyze identical substrates to different extents, but different preparations of pretreated biomass exhibit different amounts of homogeneity.

14. Quality Control

- 14.1 Reported Significant Figures or Decimal Places: Typically results are reported as percentages, calculated to two decimal places, along with the standard deviation and RPD. The assay conditions, specifically digestion time, must be defined when reporting the results.
- 14.2 Replicates: It is recommended the samples be run in duplicate to verify reproducibility.
- 14.3 Blank: Enzyme and substrate blanks are run to correct for glucose contributions other than that produced by cellulose hydrolysis.
- 14.4 Relative percent difference criteria: Not defined; dependent on the substrate being tested.
Different preparations of pretreated biomass will exhibit different amounts of homogeneity, which will influence the extent to which they are hydrolyzed.
- 14.5 Method verification standard: Solka Floc 200 NF is digested alongside the samples.
Hydrolysis is expected to be in the range of 94.00 - 96.00%.
- 14.6 Calibration verification standard: None.
- 14.7 Sample size: Dependent upon percent dry weight cellulose composition. Typically between 0.10 and 1.00 grams of sample will be required.
- 14.8 Sample storage: Pretreated samples should be stored moist, or frozen not longer than one month.
- 14.9 Standard storage: None.
- 14.10 Standard preparation: None.
- 14.11 Definition of a batch: Any number of samples which are analyzed and recorded together.
The maximum size of a batch will be limited by equipment constraints.
- 14.12 Control charts: Percent hydrolysis of Solka Floc 200 NF will be charted; use of different preparations of cellulase enzyme and total hydrolysis time will be noted.

15. Appendices

- 15.1 None.

16. References

- 16.1 NREL Ethanol Project CAT Task Laboratory Analytical Procedure #009, "Enzymatic Saccharification of Lignocellulosic Biomass", 8/19/96.
- 16.2 Grohmann, K., Torget, R., and Himmel, M. (1986), Biotech. Bioeng. Symp. No. 17, 135-151
- 16.3 Ghose, T.K. (1987), Pure & Appl. Chem., **59**, 257-268.

- 16.4 Stockton, B.C., Mitchell, D.J., Grohmann, K., and Himmel, M.E. (1991), Biotech. Let., **13**, 57-62.
- 16.5 Adney, B. and Baker, J. (1993), Ethanol Project Laboratory Analytical Procedures, LAP-006, National Renewable Energy Laboratory, Golden, CO, 80401.
- 16.6 Ehrman, C. I. (1996), Ethnaol Project Laboratory Analytical Procedures, LAP-016, National Renewable Energy Laboratory, Golden, CO, 80401.

Appendix C. Example of SAS 9.4 Code

```
PROC IMPORT OUT= WORK.Stover
  DATAFILE=
  "\\Client\C$\Users\wssymp0\Documents\Grad
  School\A
  A_thesis\Thesis\Ca(OH)2\SAS stuff\Caoh
  files\SAS numbers.xlsx"
  DBMS=EXCEL REPLACE;
  RANGE="ca-na-cs$";
  GETNAMES=YES;
  MIXED=NO;
  SCANTEXT=YES;
  USEDATE=YES;
  SCANTIME=YES;
RUN;/*data import code*/

PROC IMPORT OUT= WORK.SwGrass
  DATAFILE=
  "\\Client\C$\Users\wssymp0\Documents\Grad
  School\A
  A_thesis\Thesis\Ca(OH)2\SAS stuff\Caoh
  files\SAS numbers.xlsx"
  DBMS=EXCEL REPLACE;
  RANGE="ca-na-sg$";
  GETNAMES=YES;
  MIXED=NO;
  SCANTEXT=YES;
  USEDATE=YES;
  SCANTIME=YES;
RUN;/*data import code*/
quit;

data Stover48; set stover;
if ph="4.8";
run;/*sorts data by pH*/

data Stover55; set stover;
if ph="5.5";
run;/*sorts data by pH*/

data swgrass48; set swgrass;
if ph="4.8";
run;/*sorts data by pH*/

data swgrass55; set swgrass;
if ph="5.5";
run;/*sorts data by pH*/

proc glm data=stover48;
class yield chem;
model yield= chem;
means chem/LSD;
run;
quit;

proc glm data=stover55;
class yield chem;
model yield= chem;
means chem/LSD;
run;

proc glm data=swgrass48;
class yield chem;
model yield= chem;
means chem/LSD;
run;

proc glm data=swgrass55;
class yield chem;
model yield= chem;
means chem/LSD;
run;

proc glm data=stover;
class yield chem ph;
model yield= chem ph;
means chem ph/LSD;
run;

proc glm data=swgrass;
class yield chem ph;
model yield= chem ph;
means chem ph/LSD;
run;
```

Appendix D. Sodium Citrate Buffer Solution

A recipe for Sodium Citrate Buffer Solution taken from “Promega Protocols & Applications Guide”, chapter 15 “Buffers for Biochemical Reactions”, appendix B: Composition and Preparation of Common Buffers and Solutions,. www.promega.com, rev. 12/12

B. Preparation of Citrate Buffer (pH 3.0 – 6.2)

To create 100mL of a 0.1M citrate buffer, mix citric acid monohydrate and trisodium citrate dihydrate as given in the table below.

Solution A: 0.1M citric acid monohydrate ($C_6H_8O_7 \cdot H_2O$ FW= 210.4)

Solution B: 0.1M trisodium citrate, dihydrate ($C_6H_5O_7Na_3 \cdot 2H_2O$ FW = 294.12)

pH	Solution A (mL)	Solution B (mL)
3.0	82.0	18.0
3.2	77.5	22.5
3.4	73.0	27.0
3.6	68.5	31.5
3.8	63.5	36.5
4.0	59.0	41.0
4.2	54.0	46.0
4.4	49.5	50.5
4.6	44.5	55.5
4.8	40.0	60.0
5.0	35.0	65.0
5.2	30.5	69.5
5.4	25.5	74.5
5.6	21.0	79.0

5.8	16.0	84.0
6.0	11.5	88.5
6.2	8.0	92.0

NOTES:

Citric acid can be substituted without concern. If substituting, be sure to account for the lighter atomic weight in the molarity calculations (192.13 vs. 210.4). Rather than creating separate 0.1M solutions, the solution can be made in bulk at the desired pH by calculating the required mass of each component and adding directly to the bulk volume.

EXAMPLE:

For one liter of pH 5.0 buffer using citric acid rather than citric acid monohydrate, scale the ratios of solution A & B from the table by 10 to get 1000mL.

Required volumes: Solution A = 350mL, Solution B=650mL

Citric Acid Component:

$$0.1\text{mol/L} \times 192.13\text{grams/mol} \times 0.35\text{L/1} = 6.72\text{g CA}$$

Trisodium Citrate Dihydrate Component:

$$0.1\text{mol/L} \times 294.12\text{grams/mol} \times 0.65\text{L/1} = 19.12\text{g TCdH}$$

Add the solid components to the 1.5L flask, add stir bar, and add 1L DI water. Place on stir plate and mix until the all the solids have gone into solution. The solution should be crystal clear when ready for use.

Appendix E. **Bulk Lime/NaOH Pricing**

From: David Devine/Mid-South/Brenntag <DDevine@brenntag.com>
Sent: Wednesday, November 25, 2015 10:54
To: Sympson, William S
Subject: RE: bulk pricing

William,

This is what I have so far, not sure of the weight on the hopper truck, probably around 50,000 pounds

Hydrated Lime \$225/ton delivered

Caustic Soda Flakes/Pellets \$680/ton delivered

Let me know if you need anything else.

How do these prices compare to what you are seeing, just curious?

Thank you,

David Devine

From: Sympson, William S
Sent: Thursday, November 19, 2015 09:12
To: 'David Devine (ddevine@brenntag.com)'
Subject: bulk pricing

Bulk truckload pricing on hydrated lime and caustic soda flakes/pellets.

Thanks for the help David.

R/

William

CE Barnhart Bldg

Rm: BAE 221

REFERENCES

Association, N. L. (2007). Lime Terminology, Standards & Properties. Fact Sheet: Properties of Lime. N. L. Association. Arlington, VA. **2016**.

Ayeni, A. O., F. K. Hymore, et al. (2013). "Hydrogen peroxide and lime based oxidative pretreatment of wood waste to enhance enzymatic hydrolysis for a biorefinery: Process parameters optimization using response surface methodology." Fuel **106**: 187-194.

Brenntag (2015). Lime & NaOH Bulk Pricing. W. Symphon. Lexington, KY.

Carey, B. D. (2014). Field Implementation of Phanerochaete Chrysosporium Biomass Pretreatment: Fungal Identification and Inoculation Techniques. Biosystems and Agricultural Engineering. Lexington, KY, University of Kentucky. **Masters**.

Chang, V. S., B. Burr, et al. (1997). "Lime pretreatment of switchgrass." Applied Biochemistry and Biotechnology **63-5**: 3-19.

Chang, V. S., M. Nagwani, et al. (1998). "Lime pretreatment of crop residues bagasse and wheat straw." Applied Biochemistry and Biotechnology **74(3)**: 135-159.

Cruys-Bagger, N., J. Elmerdahl, et al. (2012). "Pre-steady-state Kinetics for Hydrolysis of Insoluble Cellulose by Cellobiohydrolase Cel7A." Journal of Biological Chemistry **287(22)**: 18451-18458.

Du, B. W., L. N. Sharma, et al. (2010). "Effect of Varying Feedstock-Pretreatment Chemistry Combinations on the Formation and Accumulation of Potentially Inhibitory Degradation Products in Biomass Hydrolysates." Biotechnology and Bioengineering **107(3)**: 430-440.

Eranki, P. L. and B. E. Dale (2011). "Comparative life cycle assessment of centralized and distributed biomass processing systems combined with mixed feedstock landscapes." Global Change Biology Bioenergy **3(6)**: 427-438.

Falls, M. and M. T. Holtzapple (2011). "Oxidative Lime Pretreatment of Alamo Switchgrass." Applied Biochemistry and Biotechnology **165(2)**: 506-522.

Hickman, A. (2015). THE EFFECTS OF INOCULUM SIZE, AIRFLOW RATE, BULK DENSITY AND PARTICLE SIZE ON THE SCALE-UP OF PHANEROCHAETE CHRYSOSPORIUM PRETREATMENT. Biosystems and Agricultural Engineering. Lexington, KY, University of KY. **Masters**.

The following full-factorial study compared fungal activity on lignocellulosic biomass that was inoculated with three different amounts of fungus, and grown using three different airflow rates. These treatments were compared to a control which consisted of biomass that was not inoculated but was exposed to the same growth conditions in the environmental chamber. The objectives of the following experiment were to determine the inoculum density and airflow rate required to optimize *Phanerochaete chrysosporium* lignin degradation. Additionally, this study quantifies the saccharification yield from the pretreated switchgrass.

The impact of substrate bulk density and substrate particle size on fungal growth were compared to determine if the particle size or the substrate bulk density has the predominant influence on the growth of the fungus, and subsequent pretreatment effectiveness quantified as an increase in glucose yields and lignin degradation. The particle size tests were controlled for bulk density; all three particle sizes were tested at a bulk density of 80 kg/m³. To test the density, three different bale densities were prepared controlling for particle size. The density tests were performed on small-scale bales made of 4 inch cut pieces of switchgrass compressed to the correct density. Therefore; density tests had the same particle size throughout all treatments, and particle size tests had the same density through all treatments. Carbohydrate accessibility post-pretreatment was examined through enzymatic saccharification and determination of glucose yields in the treatments and controls.

Hodge, D. B., M. N. Karim, et al. (2009). "Model-Based Fed-Batch for High-Solids Enzymatic Cellulose Hydrolysis." Applied Biochemistry and Biotechnology **152**(1): 88-107.

Khor, W. C., K. Rabaey, et al. (2015). "Low temperature calcium hydroxide treatment enhances anaerobic methane production from (extruded) biomass." Bioresource Technology **176**: 181-188.

Kim, S. and M. T. Holtzaple (2005). "Delignification kinetics of corn stover in lime pretreatment." Bioresource Technology **97**(5): 778-785.

Kim, S. and M. T. Holtzaple (2005). "Lime pretreatment and enzymatic hydrolysis of corn stover." Bioresource Technology **96**(18): 1994-2006.

Kristensen, J. B., C. Felby, et al. (2009). "Yield-determining factors in high-solids enzymatic hydrolysis of lignocellulose." Biotechnology for Biofuels **2**.

Kumar, D. and G. S. Murthy (2011). "Impact of pretreatment and downstream processing technologies on economics and energy in cellulosic ethanol production." Biotechnology for Biofuels **4**.

Kumar, P., D. M. Barrett, et al. (2009). "Methods for Pretreatment of Lignocellulosic Biomass for Efficient Hydrolysis and Biofuel Production." Industrial & Engineering Chemistry Research **48**(8): 3713-3729.

Leisola, M., O. Pastinen, et al. (2012). "Lignin--Designed Randomness." Bio-complexity **2012**.

Liu, H., J. Y. Zhu, et al. (2010). "Effects of Lignin-Metal Complexation on Enzymatic Hydrolysis of Cellulose." Journal of Agricultural and Food Chemistry **58**(12): 7233-7238.

Modenbach, A. A. and S. E. Nokes (2012). "The use of high-solids loadings in biomass pretreatment-a review." Biotechnology and Bioengineering **109**(6): 1430-1442.

Modenbach, A. A. and S. E. Nokes (2013). "Enzymatic hydrolysis of biomass at high-solids loadings - A review." Biomass & Bioenergy **56**: 526-544.

Modenbach, A. A. and S. E. Nokes (2014). "Effects of Sodium Hydroxide Pretreatment on Structural Components of Biomass." Transactions of the Asabe **57**(4): 1187-1198.

Nagwani, M. (1992). Calcium Hydroxide Pretreatment of Biomass. Chemical Engineering. College Station, Texas, Texas A&M. **Masters**.

Novozyme (2010). Novozyme Cellic CTec2 and HTec2 Application Sheet, Novozyme: 8.

Park, J. Y., R. Shiroma, et al. (2010). "A novel lime pretreatment for subsequent bioethanol production from rice straw - Calcium capturing by carbonation (CaCCO) process." Bioresource Technology **101**(17): 6805-6811.

Selig, M., Weiss, N., and Y. Ji (2008). Enzymatic Saccharification of Lignocellulosic Biomass. Laboratory Analytical Procedure. N. R. E. Laboratory.

Soares-Rodrigues, C. I. (2015). Evaluation of different sources of hydroxyl on biomass pretreatment and hydrolysis. Theses and Dissertations--Biosystems and Agricultural Engineering. Lexington, KY, University of Kentucky. **Masters**.

Soares Rodrigues, C. I. (2015). Evaluation of different sources of hydroxyl on biomass pretreatment and hydrolysis. Biosystems and Agricultural Engineering. Lexington, KY, University of Kentucky. **Masters**.

Sundin, J. (2000). Precipitation of Kraft Lignin under Alkaline Conditions. Pulp and Paper chemistry and technology. Stockholm, Royal Institute of Technology. **PHD**.

SunGrant (2007). Composition of Herbaceous Biomass Feedstocks. N. C. Center. Brookings, SD, South Dakota State University.

Torre, M., A. R. Rodriguez, et al. (1992). "STUDY OF THE INTERACTIONS OF CALCIUM-IONS WITH LIGNIN, CELLULOSE, AND PECTIN." Journal of Agricultural and Food Chemistry **40**(10): 1762-1766.

Vivekanand, V., E. F. Olsen, et al. (2014). "Methane Potential and Enzymatic Saccharification of Steam-exploded Bagasse." Bioresources **9**(1): 1311-1324.

Wang, Z. Y. and J. J. Cheng (2011). "Lime Pretreatment of Coastal Bermudagrass for Bioethanol Production." Energy & Fuels **25**(4): 1830-1836.

Xu, J. (2009). Alkaline Pretreatment of Switchgrass for Ethanol Production. Biological and Agricultural Engineering. Raleigh, NC, NC State University. **PHD**.

Xu, J. L., J. J. Cheng, et al. (2010). "Lime pretreatment of switchgrass at mild temperatures for ethanol production." Bioresource Technology **101**(8): 2900-2903.

Yan, Z. P., J. H. Li, et al. (2015). "Lignin relocation contributed to the alkaline pretreatment efficiency of sweet sorghum bagasse." Fuel **158**: 152-158.

VITA

William Sympson Jr.

Education

2012 – Present

University of Kentucky - Lexington, KY, United States

Master of Science: Biosystems and Agricultural Engineering | 4.0/4.0 GPA

Anticipated Graduation Date: Aug 2016

2003 – 2008

United States Navy

Civil Engineer Corps Officer School, Construction Management & Quality Control, et al

2000 – 2002

University of Kentucky - Lexington, KY, United States

Bachelor of Science: Agricultural Engineering, | 4.0/4.0 GPA

1996 – 2000

Elizabethtown Community College – Elizabethtown, KY

Associates of Applied Sciences, |4.0/4.0 GPA

Certification

May 2014

University of Kentucky - Lexington, KY, United States

Student Lean Certification: Toyota True Lean: Lean Systems Program

December 2009

Kansas Professional Engineer License 20964

Research Experience

2012 – Present

University of Kentucky - Lexington, KY, United States

Supervisor: Dr. Sue Nokes

Master's Research: Lime Pretreatment of Lignocellulosic Biomass

- Optimization lime pretreatment parameters in design of biomass to biofuel process
- Design of experiments, analysis, and testing procedures
- Designed and implemented lab scale pretreatment vessel and pumping system
- Problem solving: maintain lab equipment; set-up, rehabilitate, maintain two used 100L SIP fermenters

Presentations

American Society of Agricultural and Biological Engineers (ASABE)
 International Conference Kansas City, 2013
 Poster Presentation: Cost Reduction of the FAN Assessment Numeration System through Data Analysis

Professional Memberships

2002-Present
 American Society of Agricultural and Biological Engineers (ASABE)

Leadership Experience

July 2012-July 2016
University of Kentucky - Lexington, KY, United States
 Department of Biosystems Engineering

April 2003 – October 2008
 U.S. Navy Civil Engineer Corps
 Commissioned Naval Officer