

Research Report
KTC-97-10

EVALUATION OF WALL
STRUCTURES IN KENTUCKY
(KYSPR-85-107)

by

L. John Fleckenstein
Senior Principal Research Investigator

Brad Rister
Associate Research Engineer

and

David L. Allen
Chief Research Engineer

Kentucky Transportation Center
College of Engineering
University of Kentucky
Lexington, Kentucky

and

in cooperation with
Transportation Cabinet
Commonwealth of Kentucky

The contents of this report reflect the views of the authors who are responsible for the facts and accuracy of the data presented herein. The contents do not necessarily reflect the official views or policies of the University of Kentucky, nor the Kentucky Transportation Cabinet. This report does not constitute a standard, specification, or regulation. The inclusion of manufacturer names and trade names are for identification purposes and are not to be considered as endorsements.

March 1998

TABLE OF CONTENTS

LIST OF FIGURES	i
LIST OF TABLES	iv
EXECUTIVE SUMMARY	v
1.0 INTRODUCTION	1
2.0 PERFORMANCE EVALUATION	2
2.1 CONCRETE CRIB WALLS	2
2.1.1 Discussion	2
2.1.2 Recommendations	3
2.2 DOUBLE AND SINGLE BARREL CULVERT WALLS	13
2.2.1 Discussion	13
2.2.2 Recommendations	13
2.3 METAL BIN WALLS	24
2.3.1 Discussion	24
2.3.2 Recommendations	24
2.4 GABION WALLS	31
2.4.1 Discussion	31
2.4.2 Recommendations	32
2.5 RIGID CONCRETE RETAINING WALLS	37
2.5.1 Rigid Concrete Soil-Retention Walls	37
2.5.2 Rigid Concrete Abutment Walls with Vertical Loading	37
2.5.3 Rigid Concrete Abutment Walls without Vertical Loading	38
2.5.4 Rigid Concrete Wing Walls	38
2.5.5 Rigid Concrete Approach Fill Retaining Walls	38
2.5.6 Discussion	38
2.5.7 Recommendations	39
2.6 KEYSTONE BLOCK RETAINING WALLS	56
2.6.1 Discussion	56

2.7 TIEDBACK WALLS	60
2.7.1 Discussion	60
2.7.2 Recommendations	61
2.8 MECHANICALLY STABILIZED EARTH RETAINING WALLS (M.S.E)	69
2.8.1 M.S.E. Open Bridge Abutment Retaining Walls	69
2.8.2 M.S.E. Wing Walls	69
2.8.3 M.S.E. Closed Bridge Abutment Retaining Walls	70
2.8.4 M.S.E. Return Walls	70
2.8.5 M.S.E. Soil-Retention Walls	70
2.8.6 Discussion	71
2.8.7 Recommendations	72
2.9 TECHWALLS	97
2.9.1 Discussion	97
2.9.2 Recommendations	97
2.10 SOUND WALLS	99
2.10.1 Discussion	99
2.10.2 Recommendations	99
3.0 SUMMARY AND RECOMMENDATIONS	102
3.1 OVERALL RECOMMENDATIONS	103
Appendix A	104
Appendix B	119
Appendix C	124
Appendix D	147
Appendix E	188

LIST OF FIGURES

- Figure 1. Retaining wall inspection sheet.
- Figure 2. Soil retention crib wall.
- Figure 3. Wing wall/soil retention crib wall.
- Figure 4. Settlement in backfill between crib members (I-75 & I-71 interchange).
- Figure 5. Migration of backfill through vertical joint in crib sections (I-75 & I-71 interchange).
- Figure 6. Migration of backfill through open crib wall (Lee County, US 25).
- Figure 7. Displaced crib member due to erosion (Kenton County, KY 8).
- Figure 8. Cracking of horizontal crib member at connection (I-75 & I-71 interchange).
- Figure 9. Spalling of concrete on face of cribbing (Kenton County, KY 8).
- Figure 10. Possible post tilting of crib section (Lee County, US 25).
- Figure 11. Sluffing of unanchored ends (I-75 & I-71 interchange).
- Figure 12. Distress observed on concrete crib walls.
- Figure 13. Separation in Outlet Pipe for I-71 bridge deck drains (I-75 & I-71 interchange).
- Figure 14. Erosional channel leading from bridge deck drain to the top of the concrete crib wall.
- Figure 15. Water flowing through crib structure and freezing on the face of the crib wall.
- Figure 16. Wash-out of backfill around vertical drain (Kenton County, KY 8).
- Figure 17. Wing wall/single-barrel culvert.
- Figure 18. Wing wall/double-barrel culvert.
- Figure 19. Distress observed in culvert wing walls (double-barrel).
- Figure 20. Weephole cracking in culvert wing wall (Greenup County, KY 10).
- Figure 21. Vertical cracks in culvert wing wall (Mason County, KY 9).
- Figure 22. Horizontal cracks in culvert wing wall (Bracken County, KY 9).
- Figure 23. Vertical cracks in culvert wing wall (Bracken County, KY 9).
- Figure 24. Spalling and staining in front/top of barrel (Pendleton County, KY 9).
- Figure 25. Distress observed in culvert wing walls (single barrel).
- Figure 26. Vegetation in culvert outlet (Lewis County, KY 9).
- Figure 27. Vegetation in culvert outlet (Bracken County, KY 9).
- Figure 28. Metal bin soil retention wall.
- Figure 29. Metal bin wing wall.
- Figure 30. Metal bin wall located on US 25E exit ramp (Barbourville, Ky).
- Figure 31. Failure in vertical member in metal bin wall (Barbourville, Ky).
- Figure 32. Failure in vertical member with some lateral displacement.
- Figure 33. Bending in horizontal crib member.
- Figure 34. Metal bin wing wall on US 23 (Greenup County).
- Figure 35. Rusting observed on face of metal bin wall (Greenup County, US 23).
- Figure 36. Possible mower or vehicle damage at base of wall (Greenup County, US 23).
- Figure 37. Gabion wall sections.
- Figure 38. Gabion wall on KY 8 (Mason County).
- Figure 39. Profiles from KY 8 Gabion wall.
- Figure 40. Gabion wall on I-75/I-275 (Kenton County).
- Figure 41. Profile and sagging observed in I-75/I-275 Gabion wall.
- Figure 42. Gabion wall on I-75 (Kenton County).
- Figure 43. Rigid concrete soil-retention wall.
- Figure 44. Rigid abutment and wing retaining walls.

Figure 45. Rigid retaining wall (approach fill).

Figure 46. Observed distress for the rigid soil retention walls.

Figure 47. Cracking and staining stemming from weep hole (Jefferson County, KY 1065).

Figure 48. Cracking and staining stemming from weep hole (Floyd County).

Figure 49. Sheared key-joint in rigid wall (Jefferson County, KY 1065).

Figure 50. Sheared key-joint in rigid wall (Jefferson County, KY 1065).

Figure 51. Migration of backfill through wall drains (Knox County, 25E).

Figure 52. Migration of backfill through wall drain (Knox County, 25E).

Figure 53. Observed distress for the rigid bridge-abutment walls.

Figure 54. Observed distress for the rigid wing walls.

Figure 55. Observed distress for the rigid approach-fill walls.

Figure 56. Moderate cracking in approach-fill retaining wall (Kenton County 2nd. St.).

Figure 57. Water weeping through cracks in approach-fill wall (Kenton County).

Figure 58. Forward displacement in approach-fill retaining wall (Boone County, Mall Rd.).

Figure 59. Broken wall section caused by forward displacement (Boone County, Mall Rd.).

Figure 60. Overall view of forward displacement in approach fill retaining wall (Boone County).

Figure 61. Hole left in rigid wall after Construction (Boone County, Mall Rd.).

Figure 62. Keystone block wall, Richmond Road, Lexington.

Figure 63. Keystone block wall, Days Inn at Richmond Road & I-75, Lexington.

Figure 64. Cracks in Keystone blocks.

Figure 65a. Forward displacement between rows (sliding).

Figure 65b. Forward displacement of Keystone block wall (4 to 5 inches or 102-127 mm)

Figure 66. Migration of backfill between blocks.

Figure 67. Tiedback wall with timber lagging ties (Campbell County, US 27).

Figure 68. Tiedback wall with timber lagging ties (Carroll County, KY 227).

Figure 69. Displaced timber lagging ties (Carroll County, KY 227).

Figure 70. Broken lagging ties (Carroll County, KY 227).

Figure 71. Rusted timber lagging ties (Campbell County, US 27).

Figure 72. Rusted whaler and timber lagging ties (Campbell County, US 27).

Figure 73. Erosion of backfill (Campbell County, US 27).

Figure 74. Single tieback per whaler (Leslie County, KY 118).

Figure 75. Tieback attached to H-pile (Greenup County, US 23).

Figure 76. Slight displacement of timber lagging (Greenup County, US 23).

Figure 77. M.S.E. open bridge abutment with wing walls.

Figure 78. M.S.E. closed bridge abutment with return walls (approach fill).

Figure 79. M.S.E. soil-retention wall.

Figure 80. M.S.E. open bridge abutment distress analysis.

Figure 81. M.S.E. wing wall distress analysis.

Figure 82. Cracked precast panel and end bent, 1995 (Boone County, Mall Rd.).

Figure 83. Cracked precast panel and end bent, 1996 (Boone County, Mall Rd.).

Figure 84. Forward displacement of precast panel (Boone County, Mall Rd.).

Figure 85. Settled M.S.E. wall (Knox County, KY 225).

Figure 86. Settled M.S.E. wing wall (Knox County, KY 225).

Figure 87. M.S.E. closed bridge abutment distress analysis.

Figure 88. Extra panel between bridge deck and M.S.E. wall (Fayette County).

Figure 89. Cracking of precast panels (Fayette County).

Figure 90. C.I.P. block between bridge deck and M.S.E. wall (Boone County, Mall Rd.).
Figure 91. Migration of fines between wall panels (Jefferson County, I-264).
Figure 92. M.S.E. return walls distress analysis.
Figure 93a. Distressed area on M.S.E. wall (Kenton County, wall #1).
Figure 93b. Vertical, horizontal, and forward displacement (wall #1).
Figure 94a. Distressed area on M.S.E. wall (Kenton County, wall #2).
Figure 94b. Vertical, horizontal, and forward displacement and staining (wall #2).
Figure 95a. Distressed area on M.S.E. wall (Kenton County, wall #3).
Figure 95b. Vertical and Horizontal Displacement (wall #3).
Figure 96. Ruler placed 559 mm into panel joint (Kenton County, wall #3).
Figure 97. Spalling of precast panels (Fayette County).
Figure 98. Staining and vegetation growing between precast panels (Fayette County).
Figure 99. Vegetation growing between precast panels (Jefferson County, I-264).
Figure 100. Water standing behind V.S.L. wall (Kenton County, I-75).
Figure 101. TechWall on 12th Street Ramp, Kenton County.
Figure 102. TechWall with patched area, spalling, and staining (Kenton County).
Figure 103. Staining and spalling between panel joints (Kenton County).
Figure 104. Brick sound wall (Jefferson County, I-264).
Figure 105. Metal sound wall (Scott County).
Figure 106. Chipped bricks on sound wall caused by mower (Jefferson County, I-264).
Figure 107. Dented metal on sound wall caused by mowers (Scott County).

LIST OF TABLES

- Table 1. Distress observed in soil-retention crib walls.
- Table 2. Distress observed in soil retention/wing crib walls.
- Table 3. Distress observed in Culvert Wing Walls (Double-Barrel).
- Table 4. Distress observed in Culvert Wing Walls (Single-Barrel).
- Table 5. Distress observed in Metal Bin Walls (Soil Retaining Wall).
- Table 6. Distress observed in Metal Bin Walls (Bridge Wing Wall).
- Table 7. Distress observed in Gabion Walls.
- Table 8. Distress observed in Rigid Retaining Walls (Soil-Retention).
- Table 9. Distress observed in Rigid Retaining Walls (Bridge Abutment) Load Bearing.
- Table 10. Distress observed in Rigid Retaining Walls (Bridge Abutment) Non-Load Bearing.
- Table 11. Distress observed in Rigid Retaining Walls (Wing Wall).
- Table 12. Distress observed in Rigid Retaining Walls (Approach Fill).
- Table 13. Distress observed in Tiedback Walls (Wood lagging held with ties).
- Table 14. Distress observed in Tiedback Walls (Wood lagging placed between soldier beams).
- Table 15. Distress observed in Tiedback Walls. (Concrete Facing).
- Table 16. M.S.E. Retaining Wall (Open Bridge Abutment).
- Table 17. M.S.E. Retaining Wall (Bridge Abutment Wing Wall).
- Table 18. M.S.E. Retaining Wall (Closed Bridge Abutment).
- Table 19. M.S.E. Retaining Wall (Bridge Abutment) Return Walls.
- Table 20. M.S.E. Earth Retention Wall.

EXECUTIVE SUMMARY

Approximately 209 retaining wall structures were visually evaluated under this study for long-term performance. The inspection included concrete crib, single-barrel and double-barrel culvert wing, metal bin, Gabion, rigid concrete, Keystone block, tiedback, mechanically stabilized earth (M.S.E.), TechWall, and sound walls. Significant structural distress was observed in several of the wall systems. This report discusses the performance of each wall system and makes recommendations on the future use of these systems.

1.0 INTRODUCTION

In the past decade, numerous wall systems have been constructed on Kentucky's highways. These walls include such systems as concrete crib, single-barrel and double-barrel culvert wing, metal bin, Gabion, rigid concrete, tiedback, M.S.E., TechWall, and sound walls. In addition to the walls mentioned, the Keystone block wall was also evaluated. A study was initiated in 1996 to evaluate these systems. Approximately 209 retaining wall structures were visually evaluated under this study for long-term performance. This report discusses the performances of each wall system and makes recommendations on their future use.

The initial step in this project was to review the Kentucky Standard Specifications for Road and Bridge Construction (Appendix A), the Standard Drawings (Appendix B), the general notes (Appendix C), the Special Provisions and Special Notes (Appendix D), and the manufactures' literature that pertained to retaining wall structures (Appendix E). A list of different retaining wall structures was then compiled. Then, each wall was visually inspected for any signs of distress. Performance information was entered on a field performance data sheet develop for this study. Each wall system was subdivided into nine sections for analysis purposes (Figure 1). In addition, each wall system was photographed and video taped. Distress information from the data sheets was placed into a computer database for analysis. The following discussion details the performance of each wall system that was inspected.

RETAINING WALL DATA SHEET																		
COUNTY: _____ ROUTE: _____ MILEPOST: _____ DIRECTION: _____ GPS: _____ WALL HEIGHT: _____ WALL LENGTH: _____			AGENCY 1. RESD 2. ORAV 3. CANT 4. ARCH 5. MAJ 6. PREPAR 7. MOD		WALL USE 1. END BENT 2. WIND WALL 3. EARTH RET. 4. NOISE 5. OTHER		PHOTO DISK NO. IMAGE NO. ROLL NO. PHOTO NO. TAPE NO. START END		DISTRESS 1. VERT. DISP. 5. SPALLING 2. HORIZ. DISP. 6. RUSTING 3. FORWARD DISP. 7. STAINING 4. CRACKING 8. OTHER									
							<table border="1" style="width: 100%; border-collapse: collapse;"> <tr> <td style="width: 33%;">1</td> <td style="width: 33%;">2</td> <td style="width: 33%;">3</td> </tr> <tr> <td>4</td> <td>5</td> <td>6</td> </tr> <tr> <td>7</td> <td>8</td> <td>9</td> </tr> </table>			1	2	3	4	5	6	7	8	9
1	2	3																
4	5	6																
7	8	9																
							GENERAL NOTES OR SKETCH OF WALL											
QUAD	DISTRESS	PHOTO	THERMO	COMMENTS														
1																		
2																		
3																		
4																		
5																		
6																		
7																		
8																		
9																		

Figure 1: Retaining Wall Inspection Sheet

2.0 PERFORMANCE EVALUATION

2.1 CONCRETE CRIB WALLS

A total of four concrete crib walls was visually inspected, in this study. The crib walls inspected consisted of both open-face and closed-face designs. The walls were subdivided into two categories: 1) stand-alone soil-retention structures (Figure 2), and 2) retention/bridge wing walls (Figure 3).

In evaluating the performance of the stand-alone retention walls and wing walls/retaining walls, no significant difference was found in the performance of these structures. Several types of distress were observed in the crib wall systems including: 1) migration of backfill through the crib members (Figures 4-6), 2) displaced crib members due to erosion (Figure 7), 3) cracking of the crib members (Figure 8), 4) spalling of the face of crib members (Figure 9), 5) slight bulging or tilting (Figure 10), and 6) sluffing of unanchored ends (Figure 11).

Distress information from the inspection of the crib walls is contained in Table 1 and Table 2. As shown in the tables, the significance of the observed distress (concerning the overall performance of the wall system) was ranked from "A" being slight, to "C" being severe. The location of the distress is visually plotted for each crib wall in Figure 12.

2.1.1 Discussion

The crib wall retaining systems appear to have performed well for the time they have been in service. The erosion of the backfill on the I-75 wall has been accelerated by water being discharged up-grade from a broken deck drain for the I-71 interchange (Figures 13-15). A paved or concrete ditch behind the crib wall on KY 8 appears to be discharging on top of the wall and has caused erosion of the backfill adjacent to a vertical pipe (Figure 16). Migration of the backfill was apparent in all nine sections in the open-face crib wall structure on KY 52. It appears that the backfill was initially undersized.

Cracking observed in the crib members appears to be more common with the closed face wall systems and occurs at the connection of the forward and horizontal cribs. The cracking appears to be the result of bending occurring at the notch in the horizontal member where the crib is substantially thinner. The cracking does not appear to be affecting the performance of the wall system.

Spalling of the concrete was observed on the KY 8 crib wall. It appears the reinforcing steel was placed too close to the surface of the concrete.

Tilting and/or bulging was observed in two of the crib walls. Rearward tilting was observed on the US 52 wall in Lee County and slight bulging was apparent on the I-75 crib wall. Migration or erosion of the backfill was also apparent in both of the walls. Slight shifting of the crib was also observed at the ends of three of the walls. This appears to have been caused by erosion of the backfill around the cribbing.

2.1.2 Recommendations (Crib Walls)

The migration of the backfill through the cribbing appears to be the most significant problem observed in the crib wall systems. It is apparent that water being discharged behind the I-75 and KY 8 structures is largely contributing to the migration of the fines. As with most retaining structures, surface runoff should be diverted away from the top of the retaining structure. A non-erodible granular backfill should be used to prevent the migration of the backfill, and the surrounding soil, through the crib structure. If the backfill is classified as erodible or unstable it shall be protected by geotextile fabric as stated in Special Provision No. 69G (94) (Appendix D).

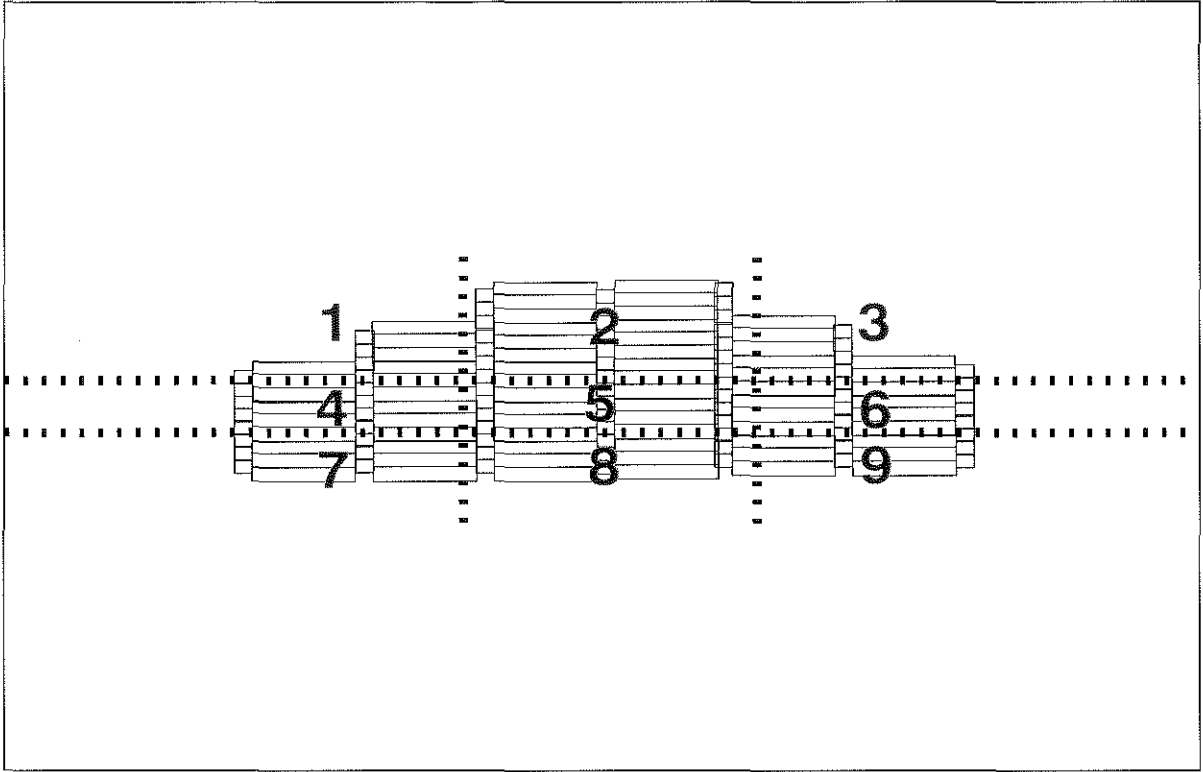

Figure 2: Soil Retention Crib Wall

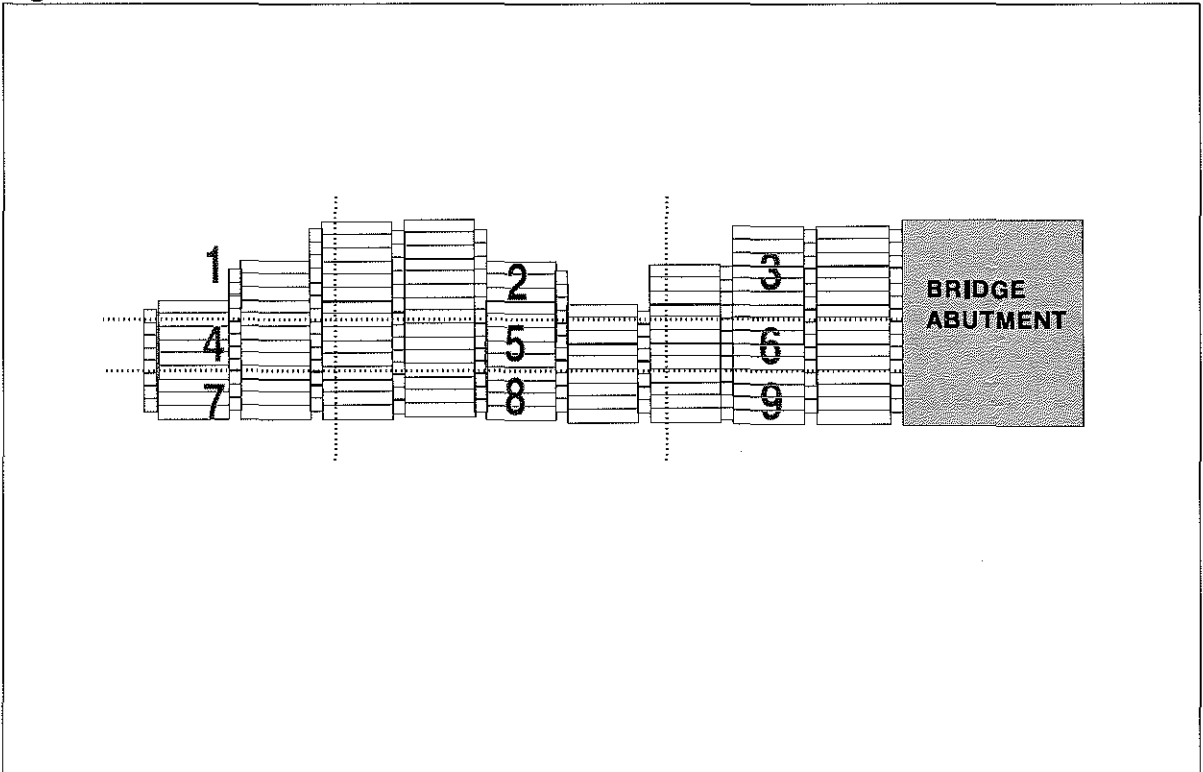

Figure 3: Wing Wall/Soil Retention Crib Wall

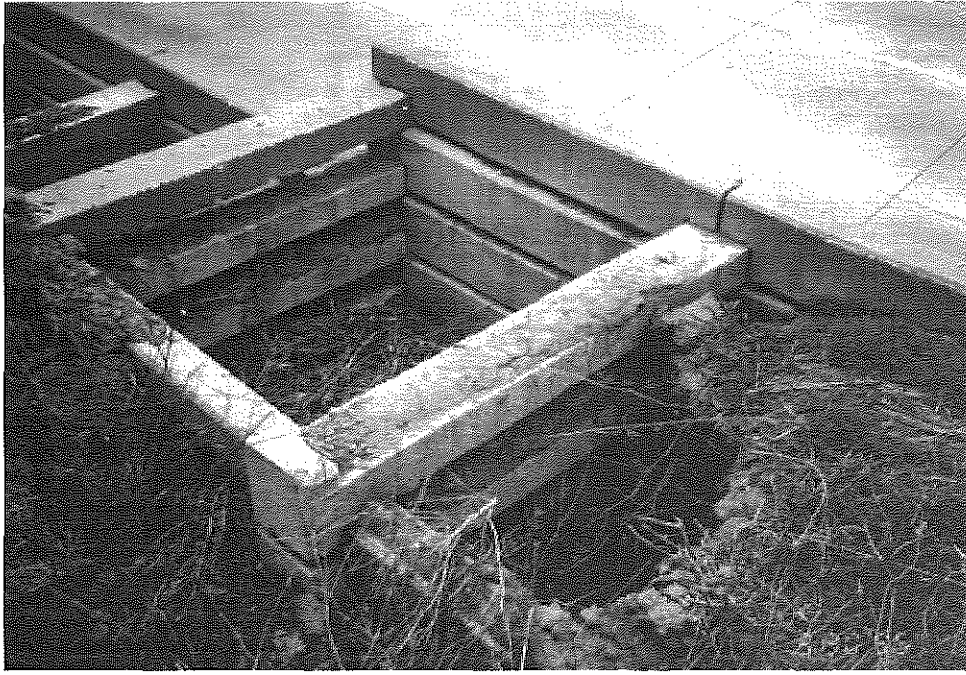

Figure 4: Settlement in Backfill between Crib Members.
(I-75 and I-71 Interchange)



Figure 5: Migration of Backfill Through Vertical
Joint in Crib Sections. (I-75 & I-71 Inter.)

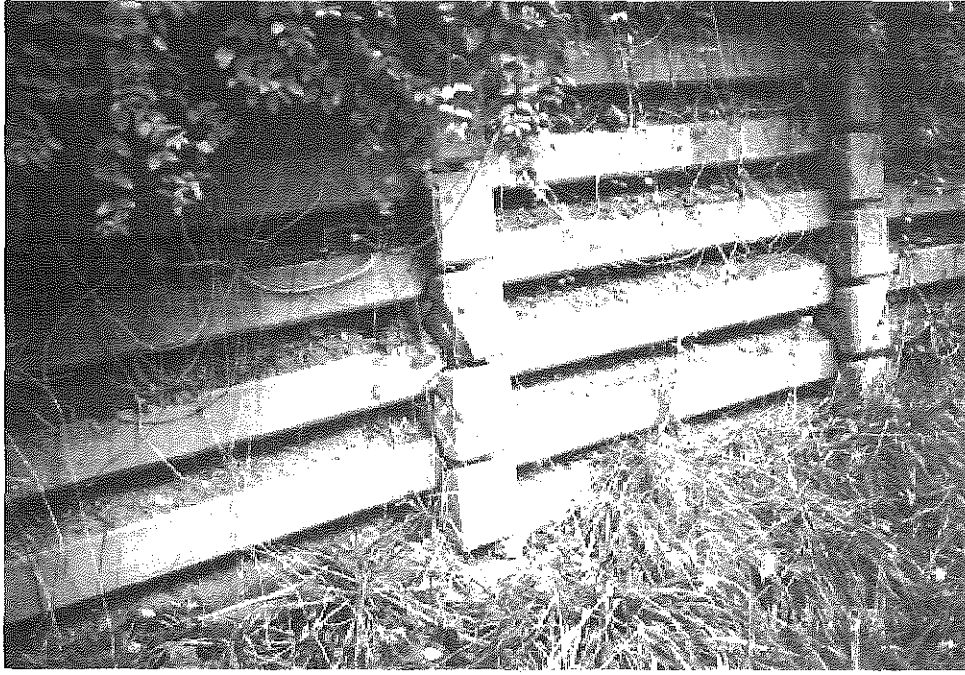

Figure 6: Migration of Backfill Through Open Face Crib Wall.
(Lee County, US 52)



Figure 7: Displaced Crib Member Due to Erosion.
(Kenton County, KY 8)



Figure 8: Cracking of Horizontal Crib Member at Connection.
(I-75 & I-71 Interchange)



Figure 9: Spalling of Concrete on Face of Cribbing.
(Kenton County, KY 8)



Figure 10: Possible Post Tilting of Crib Section.
(Lee County, US 52)



Figure 11: Sluffing of Unanchored Ends.
(I-75 & I-75 Interchange)

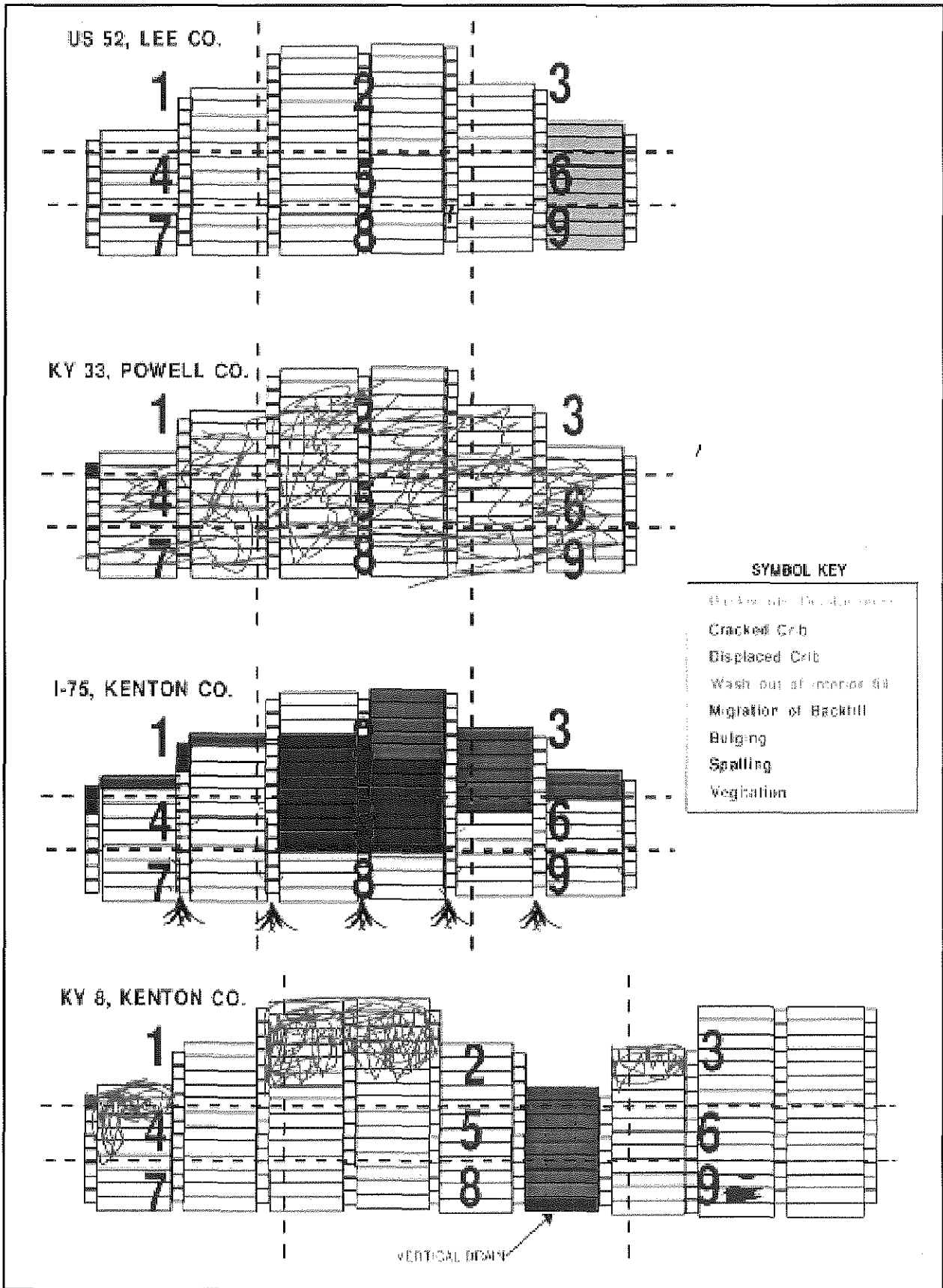

Figure 12: Distress Observed on Concrete Crib Walls



Figure 13: Separation in Outlet Pipe for I-71 Bridge Deck Drain.
(I-75 & I-71 Interchange)



Figure 14: Erosional Channel Leading from Bridge Deck Drain to the Top
of the Concrete Crib Wall. (I-71 & I-75 Interchange)

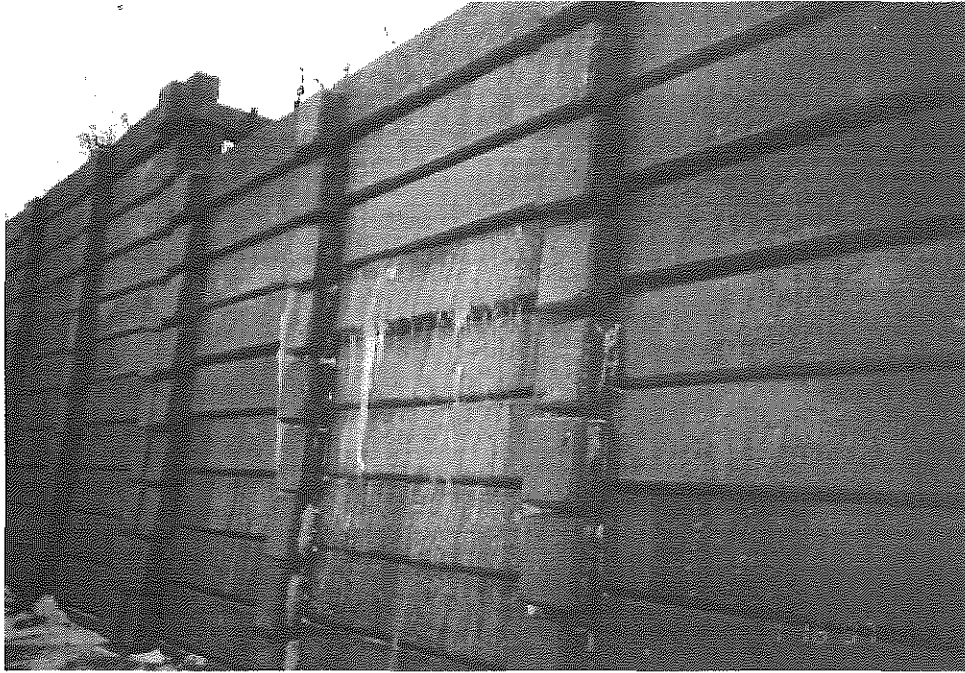

Figure 15: Water Flowing Through Crib Structure and Freezing on the Face of the Crib Wall. (I-75 & I-71 Interchange)



Figure 16: Wash out of Backfill Around Vertical Drain. (Kenton County, KY 8)

TABLE 1. Soil Retention Crib Wall (open and closed face)

LOCATION				SECTIONS								
				OBSERVED DISTRESS								
COUNTY	RT	MP	DIR	1	2	3	4	5	6	7	8	9
Lee (open) fig. 6,10	US 52	n/a	n/a	7b	7b	3b,7b	7b	7b	3b,7b	7b	4b,7b	3b,7b
Powell (open) fig. n/a	KY 33	n/a	n/a	5a,4a,10b	10b	10b	10b	10b	10b	10b	10b	10b
Kenton (cld) fig. 4,5,8,11,15	I75/71	187.7	N	4b,5b,6a	4b,6c,8b	4b,6c	4b	4b,8b	4b,6c	4b,7b	4b,7b	4b,7c
				DISTRESS OBSERVED AVG. (%)								
				3a=33%	4b=33%	3b=33%	4b=33%	4b=33%	3b=33%	4b=33%	4b=66%	3b=33%
				4a=33%	6c=33%	4b=33%	7b=33%	5a=33%	4b=33%	7b=66%	7b=66%	4b=33%
				4b=33%	7b=33%	6c=33%	10b=33%	7b=33%	6c=33%	10b=33%	10b=33%	7b=33%
				5b=33%	8b=33%	7b=33%		8b=33%	7b=33%			7c=33%
				6a=33%	10b=33%	10b=33%		10b=33%	10b=33%			10b=33%
				7b=33%								
				10b=33%								

TABLE 2. Soil Retention Crib /Wing Wall (closed face)

LOCATION				SECTIONS								
				OBSERVED DISTRESS								
COUNTY	RT	MP	DIR	1	2	3	4	5	6	7	8	9
Kenton (cld) fig. 7,9,16	KY 8	7.57	W	4b,5b	10b	6c		10b	5b,6c		9b,10b	5c,6c,9b
				DISTRESS OBSERVED AVG. (%)								
				4b=100%	10b=100%	6c=100%		10b=100%	5b=100%		9b=100%	5b=100%
				5b=100%					6c=100%		10b=100%	6c=100%
												9b=100%

DISTRESS
 1. VERT. DISP.
 2. HORIZ. DISP.
 3. BACKWARDS DISP.
 4. CRACKED CRIB MEMBERS
 5. DISP. CRIB MEMBERS(DUE TO EROSION)
 6. WASH OUT OF INTERIOR FILL
 7. MIGRATION OF BACKFILL
 8. BULGING
 9. SPALLING
 10. VEGETATION

SIGNIFICANCE OF DISTRESS
 A = SLIGHT B = MODERATE
 C = SEVERE

2.2 SINGLE-BARREL AND DOUBLE-BARREL CULVERT WING WALLS

Fifty-two culvert wing walls were visually inspected. Of the fifty-two wing walls inspected, thirty-two were double-barrel culvert wing walls, and twenty were single-barrel culvert wing walls. As shown in Figures 17 and 18, each wall was divided into ten different sections to help quantify repeated distress patterns.

In evaluating the performance of the double-barrel and single-barrel culvert wing wall systems, no significant difference was observed in the performance of these structures. On the average, both wall systems have performed well. The only distress that was recurring in both wall systems was slight-to-moderate cracking and staining. Most of the cracking mentioned in the culvert wing wall evaluation can be attributed to shrinkage cracks.

Four different kinds of distress were observed in the double-barrel culvert wing walls; cracking, spalling, staining, and pop-out. The majority of the distress was either slight-to-moderate cracking or staining. A statistical analysis shows that 34 to 39 percent of the cracking was observed in sections two, five, and eight (Figure 19). Photos taken from two locations show the vertical cracks in those sections (Figures 20 and 21). There is some concern that the length of the wing wall may be a contributing factor in the occurrence of cracks in sections two, five, and eight. Figure 21a shows a regression curve of actual field data that displays as the length of the wing wall increases over 6 meters (20 ft.) the number of cracks observed increases. Sections one, four, and seven also had slight-to-moderate cracking (Figures 22 and 23). The majority of the cracks observed in section one were horizontal cracks. Staining, cracking, spalling, and pop-outs were observed in section ten (Figure 24).

The single-barrel culvert walls' distress patterns were very similar to the double-barrel wall systems. A statistical analysis shows slight to moderate cracking in sections one, two, four, five, seven, and eight (Figure 25).

Distress information from the inspection of the double-barrel and single-barrel culvert walls is contained in Tables 3 and 4. As shown in the tables, the significance of the observed distress (concerning the overall performance of the wall system) was ranked from "A" being slight, to "C" being severe.

2.2.1 Discussion

The double-barrel and single-barrel culvert wing wall systems appear to have performed well. Cracking has occurred in both systems in the same sections; one, two, four, five, seven, and eight. However, the cracks are slight to medium in magnitude. The majority of the cracks can be attributed to shrinkage cracks, and are probably not an indication of faulty design or construction. One problem that is not related to the performance of the wing wall system, but is reducing the efficiency of the culvert is the overgrowth of vegetation in the mouth to the culvert (Figures 26 and 27).

2.2.2 Recommendation (Culvert Walls)

The slight-to-moderate cracking that is occurring in sections two, five, and eight is irregular in appearance, and could be controlled by saw cutting the surface for a straight relief joint. Spalling occurring on the horizontal face of the top slab of the culvert is likely due to water saturating the top of the culvert. A possible solution to deter spalling on the horizontal face would be to cover or seal the top horizontal face with a waterproof geomembrane. Maintenance crews should periodically

check the inlet and outlet ends of the culvert for buildup of debris or vegetation, and take any necessary actions to clean up obstructions blocking the culvert.

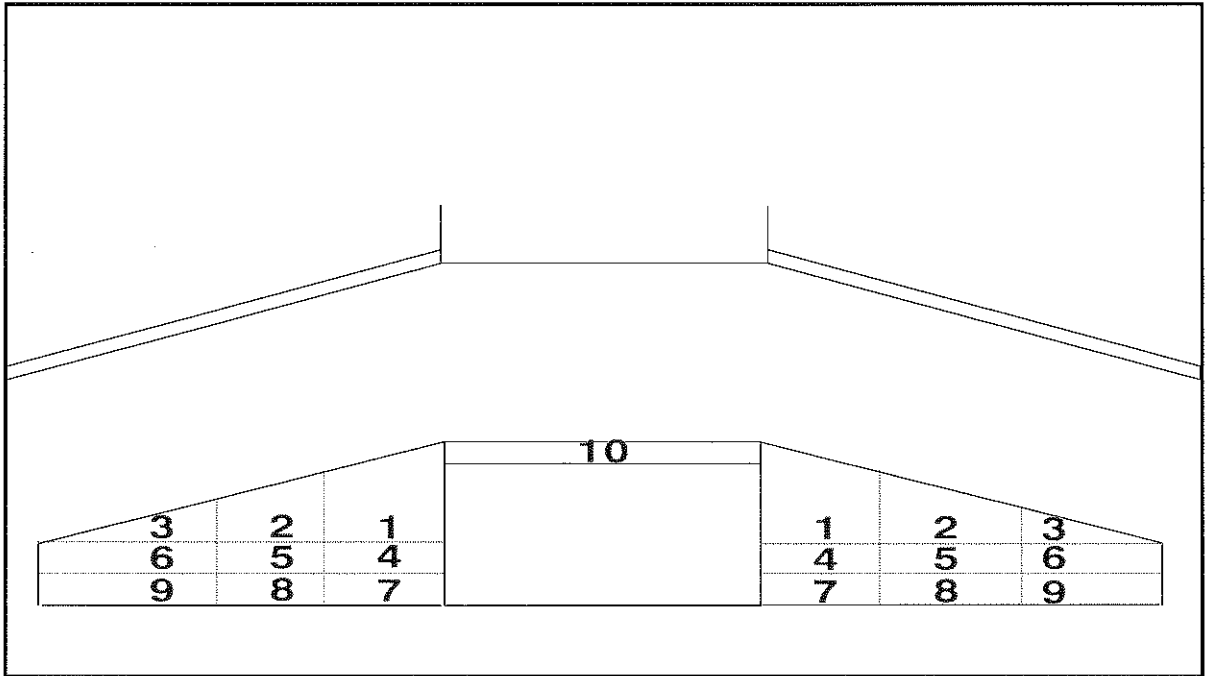

Figure 17: Wing Wall/Single Barrel Culvert

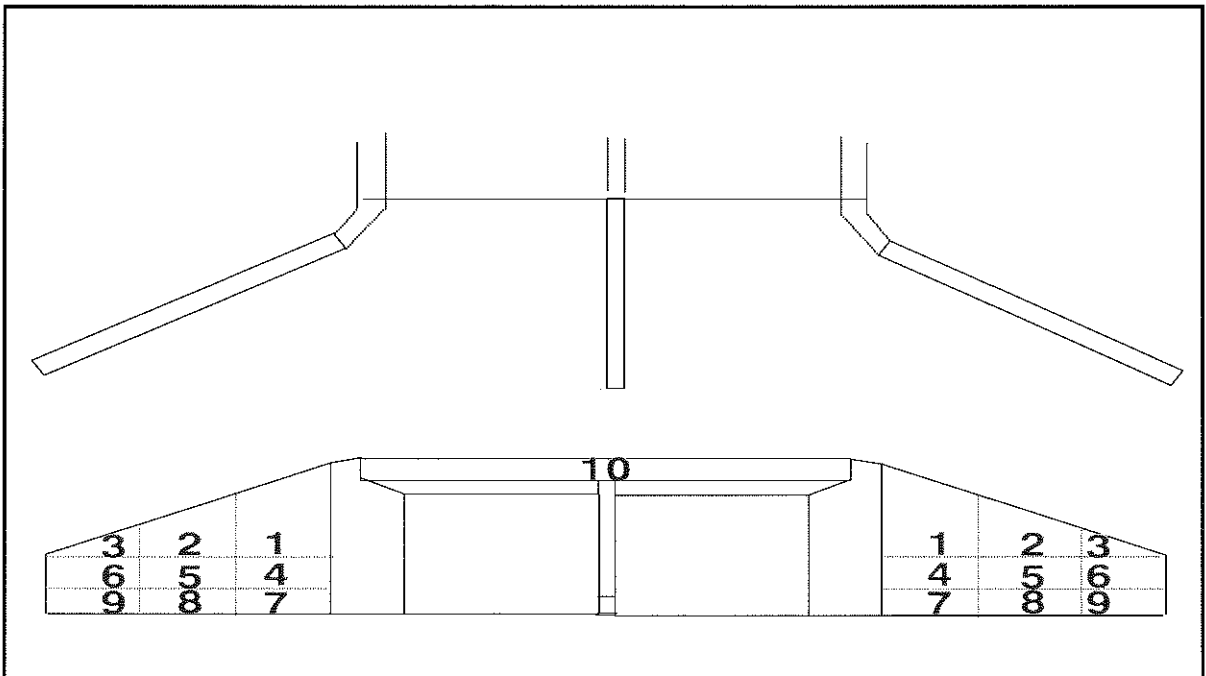

Figure 18: Wing Wall/Double Barrel Culvert

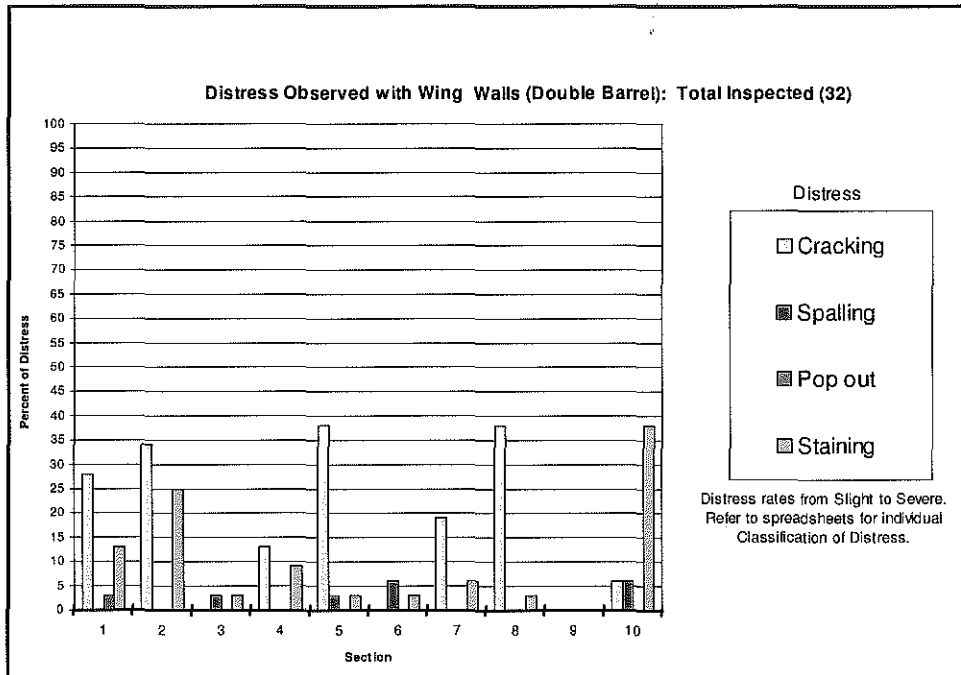

Figure 19: Distress Observed in Culvert Wing Walls (Double Barrel)

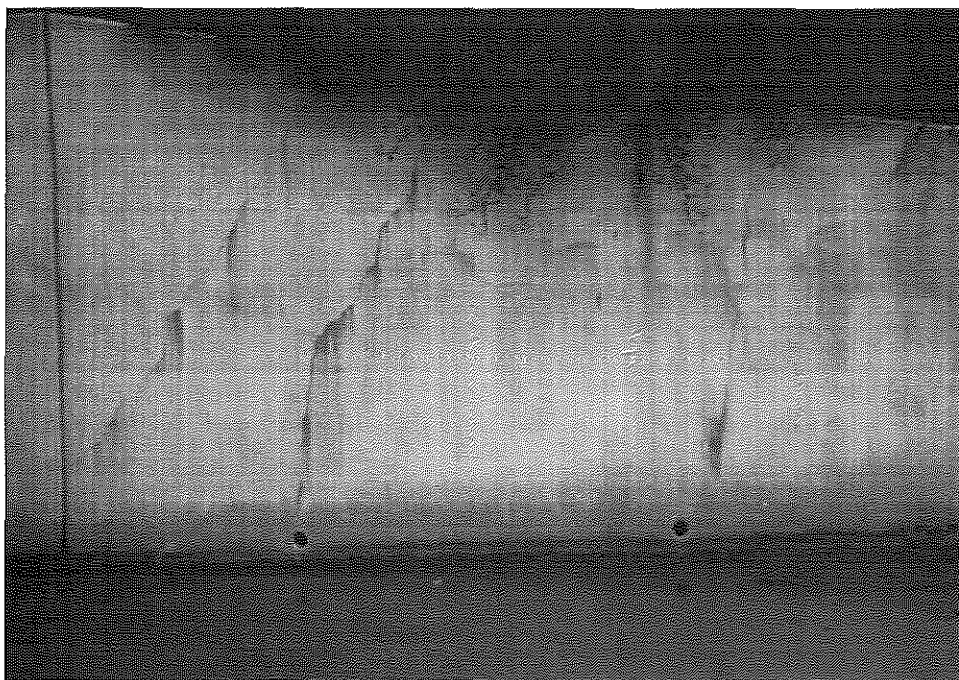

Figure 20: Weep hole Cracking in Culvert Wing Wall (Greenup County, KY 10, Milepost 3.25)

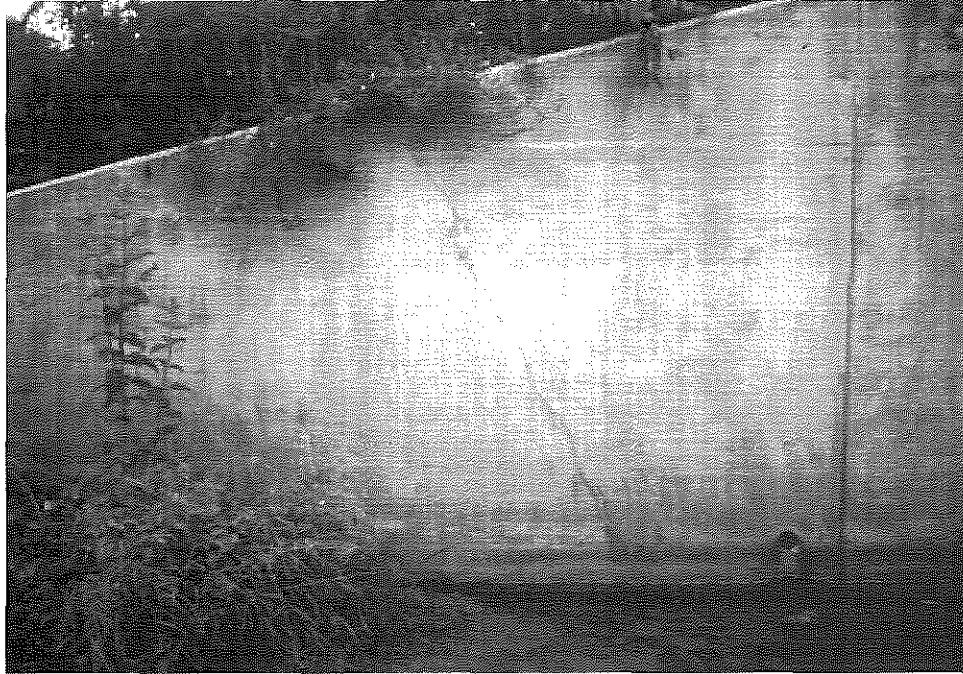

Figure 21: Vertical Cracks in Culvert Wall
(Mason County, KY 9, Milepost 18.46)

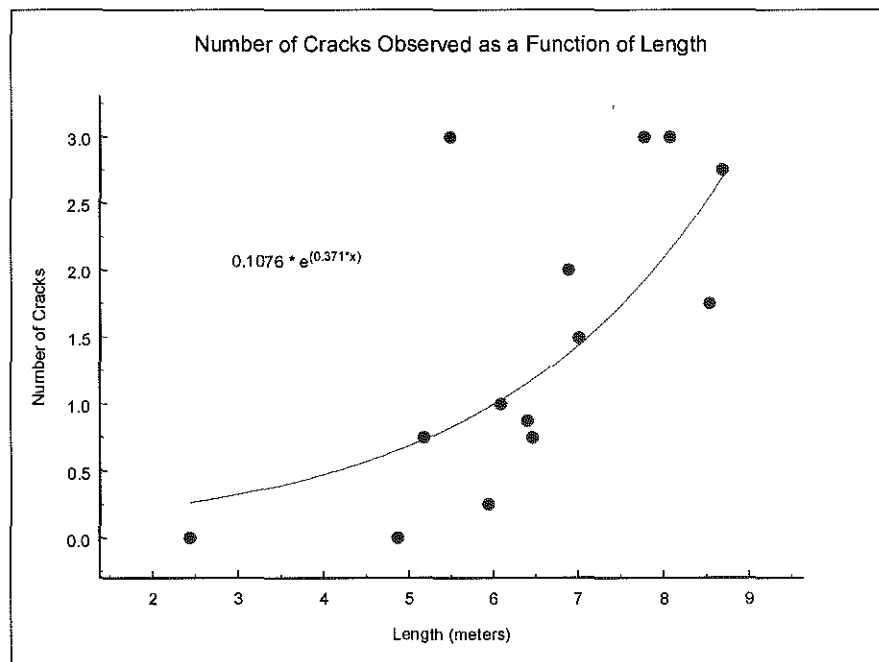

Figure 21a: Length of Wing Wall Vs. Occurrence of Cracks

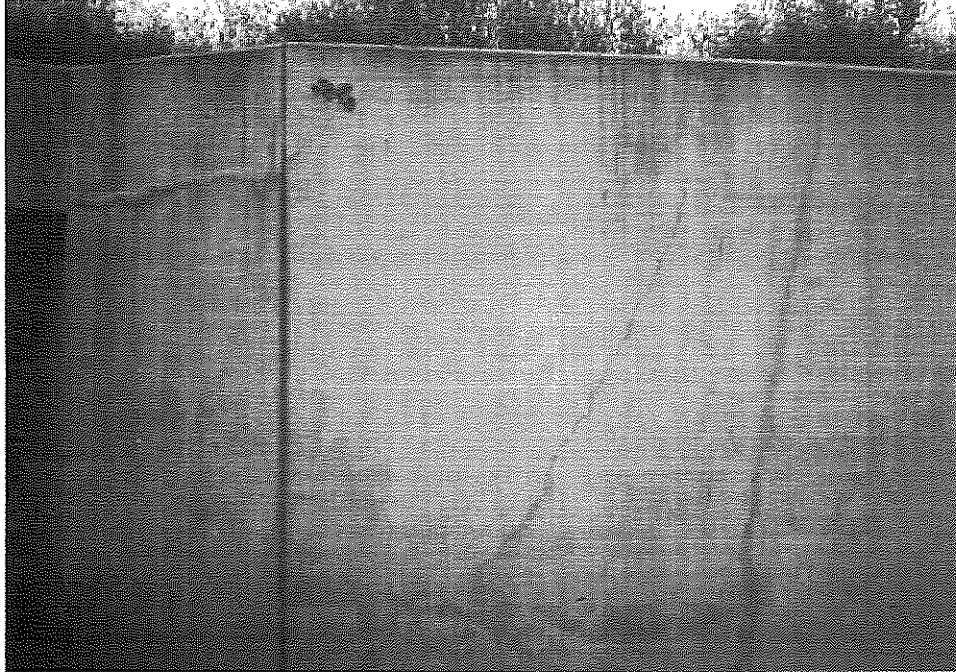

Figure 22: Horizontal Cracks in Culvert Wing Wall
(Bracken County, KY 9, Milepost 12.59)

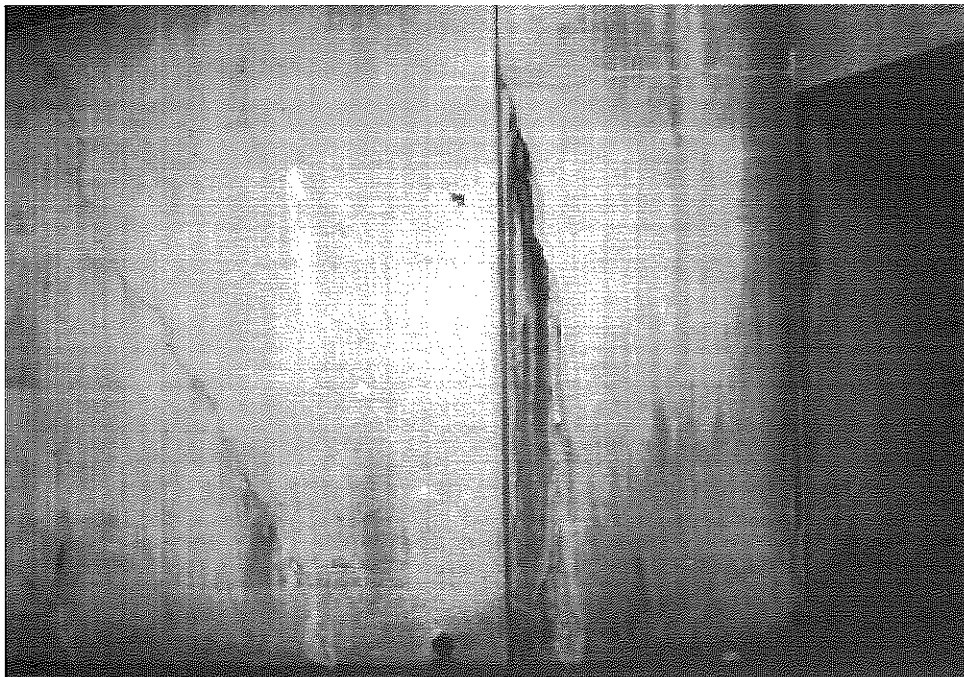

Figure 23: Vertical Cracks in Culvert Wing Wall
(Bracken County, KY 9, Milepost 12.59)

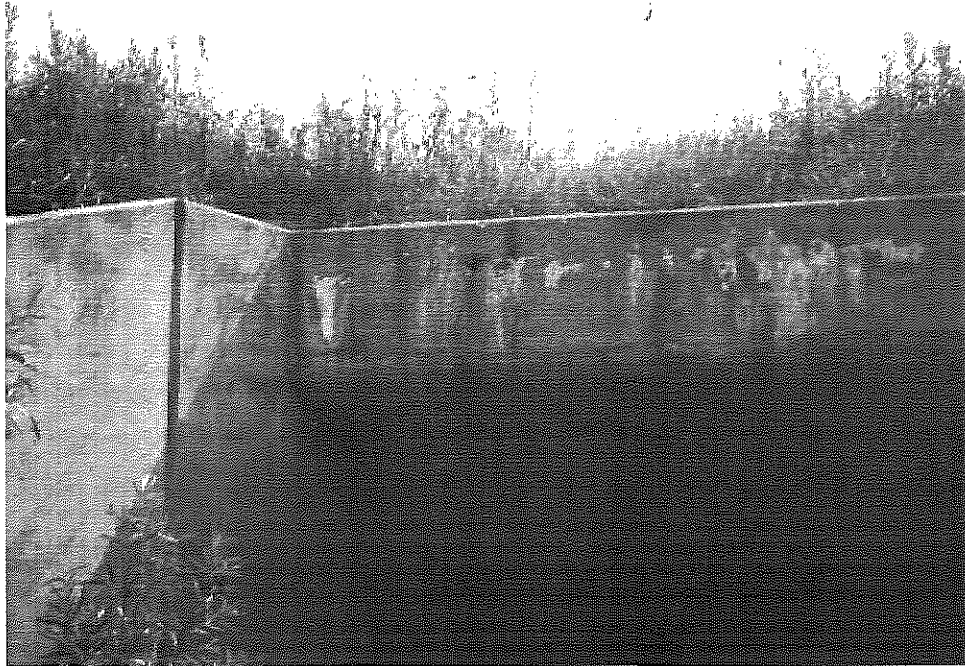

Figure 24: Spalling and Staining in Front/Top of Barrel
(Pendleton County, KY 9, Milepost 2.73)



Figure 25: Distress Observed in Culvert Wing Walls (Single Barrel)



Figure 26: Vegetation in Culvert Outlet.
(Lewis County, KY 9, Milepost 25)



Figure 27: Vegetation in Culvert Outlet
(Bracken County, KY 9, Milepost 4.46)

TABLE 3. CULVERT WING WALL (DOUBLE BARREL)

LOCATION				SECTIONS									
				OBSERVED DISTRESS									
COUNTY	RT	MP	DIR	1	2	3	4	5	6	7	8	9	10
PENDELTON	KY9	2.73	EB/WW		4a		4a			4a			5b
fig. n/a			EB/EW		4b			4b			4b		
PENDELTON	KY154		EB/WW										
fig. 24			EB/EW		4a			4a		4a	4a		
BRACKEN	KY9	12.59	NB/NW	4b	4a		7a	4a	5a		4a		
fig. 22,23			NB/SW	4a	4a	5a	4b,7b	4a,5a	5a	4b,7b	4a		
			SB/NW		4a			4a			4a		7a
			SB/SW	4a				4a			4a		
LEWIS	KY9	25.185	NB/NW	4a,7a									7a
fig. 26			NB/SW										
			SB/NW		4a			4a			4a		
			SB/SW										
LEWIS	KY9	21.2	NB/WW	7b,6b									4a
fig. n/a			NB/SW	4a									7a
			SB/NW										
			SB/SW										
GREENUP	KY9	4	WB/WW	7b			7b			7b			7a
fig. n/a			WB/EW	4a,7b									
			EB/WW										
			EB/EW		7b	7b		7b	7b		7b		

DISTRESS

- 1. VERT. DISP.
- 2. HORIZ. DISP.

- 3. FORWARD DISP.
- 4. CRACKING

- 5. SPALLING
- 6. POP OUT

- 7. STAINING

SIGNIFICANCE OF DISTRESS

- A = SLIGHT
- B = MODERATE
- C = SEVERE

TABLE 3. CONTINUED. WING WALL (DOUBLE BARREL)

LOCATION				SECTIONS									
				OBSERVED DISTRESS									
COUNTY	RT	MP	DIR	1	2	3	4	5	6	7	8	9	10
GREENUP	KY10	3.25	WB/WW				4b			4b			7a
fig. 20			WB/EW										
			EB/WW					4a			4a		7a
			EB/WW	4b	4a		4b	4a		4b	4a		
BRACKEN	KY9	18.255	NB/NW		4a			4a			4b		
fig. n/a			NB/SW										
			SB/NW		4b			4b			4b		
			SB/SW		4b			4b			4b		
LEWIS	KY9	27.85	NB/NW										
fig. n/a			NB/SW	4a									
			SB/NW										
			SB/SW	4a,7a									
				SECTIONS									
				1	2	3	4	5	6	7	8	9	10
				DISTRESS OBSERVED AVG. (%)									
				4a=21%	4a=25%	5a=3%	4a=3%	4a=28%	5a=6%	4a=9%	4a=25%		4a=6%
				4b=6%	4b=9%	7b=3%	4b=9%	4b=9%	7b=3%	4b=9%	4b=12.5%		5b=6%
				6b=3%	7b=25%		7a=3%	5a=3%		7b=6%	7b=3%		7a=38%
				7a=3%			7b=6%	7b=3%					
				7b=9%									

DISTRESS
 1. VERT. DISP.
 2. HORIZ. DISP.

3. FORWARD DISP.
 4. CRACKING

5. SPALLING
 6. POP OUT

7. STAINING

SIGNIFICANCE OF DISTRESS
 A = SLIGHT
 B = MODERATE
 C = SEVERE

TABLE 4: CULVERT WING WALL (SINGLE BARREL)

LOCATION				SECTIONS									
				OBSERVED DISTRESS									
COUNTY	RT	MP	DIR	1	2	3	4	5	6	7	8	9	10
LEWIS	KY 10	17.7	WB/WW										
fig. n/a			WB/EW								4a		
			EB/WW										
			EB/EW										
BRACKEN	KY 9	2.0	NB/NW	4a,7a									
fig. n/a			NB/SW	4a,7a							4a		
			SB/NW										4a
			SB/SW	4a	4a			4a		4a			
BRACKEN	KY 9	4.46	NB/NW					4a			4a		7b
fig. n/a			NB/SW					4a			4a		
			SB/NW		4a			4a			4a		
			SB/SW	7a			4a			4a			
MASON	KY 9	18.465	NB/NW		4b		4b			4b			
fig. n/a			NB/SW		4b		4b			4b			7a
			SB/NW		4a			4a					
			SB/SW		4a			4a					7a
CAMPBELL	AA	16.36	WB/WW				4a			4a			
fig. n/a			WB/EW										7a
			EB/WW		4c		4c						
			EB/EW	7a	4c		4c,7a			4c,7a			7a

DISTRESS

- 1. VERT. DISP.
- 2. HORIZ. DISP.

- 3. FORWARD DISP.
- 4. CRACKING

- 5. SPALLING
- 6. POP OUT

- 7. STAINING

SIGNIFICANCE OF DISTRESS

- A = SLIGHT
- B = MODERATE
- C = SEVERE

TABLE 4. CONTINUED. WING WALL (SINGLE BARREL)

				SECTIONS									
				1	2	3	4	5	6	7	8	9	10
				DISTRESS OBSERVED AVG. (%)									
				4a=15%	4a=20%		4a=10%	4a=30%		4a=15%	4a=25%		4a=10%
				7a=20%	4b=10%		4b=10%			4b=10%			7a=40%
					4c=10%		4c=10%			4c=10%			7b=10%
							7a=5%			7a=5%			

DISTRESS

- 1. VERT. DISP.
- 2. HORIZ. DISP.

- 3. FORWARD DISP.
- 4. CRACKING

- 5. SPALLING
- 6. POP OUT

- 7. STAINING

SIGNIFICANCE OF DISTRESS

- A = SLIGHT
- B = MODERATE
- C = SEVERE

2.3 METAL BIN WALLS

Metal bin retaining walls were evaluated in Knox and Greenup Counties. Five walls were inspected, four of which served as wing walls to bridge abutments (Greenup Co.) and one that was a stand-alone soil retention wall (Knox Co.). Each wall type was divided into nine sections for inspection and analysis purposes (Figures 28 and 29). The Knox County wall was located along US 25E at the Barbourville exit ramp (Figure 30). Significant distress was observed in the center of the wall. Five of the vertical support members had failed at the base of the wall (Figures 31 and 32), and bending was occurring in some of the horizontal members (Figure 33).

The metal bin wing walls in Greenup County appear to have performed well (Figure 34). Three of the four walls had slight to moderate rust in sections (Figure 35). Two of the four walls had been dented at the base (section 9) (Figure 36).

Distress information from the inspection of the metal bin walls is contained in Tables 5 and 6. As shown in the tables, the significance of the observed distress (concerning the overall performance of the wall system) was ranked from "A" being slight, to "C" being severe.

2.3.1 Discussion

Failures in the vertical supports of the metal bin retaining wall on US 25 in Knox County are likely due to post construction settlement of the backfill. Although severe buckling has occurred in some of the vertical supports, the wall does not appear to be in immediate danger of collapsing. Further inspection and monitoring are recommended at this time.

The metal bin walls in Greenup County appear to be performing well. A significant amount of spot rusting was observed. The walls should be painted to help reduce rusting.

2.3.2 Recommendations

Continue to monitor the metal bin wall on U.S. 25E in Knox County for further vertical settlement. Paint the face of metal bin walls with a rust resistant coating.

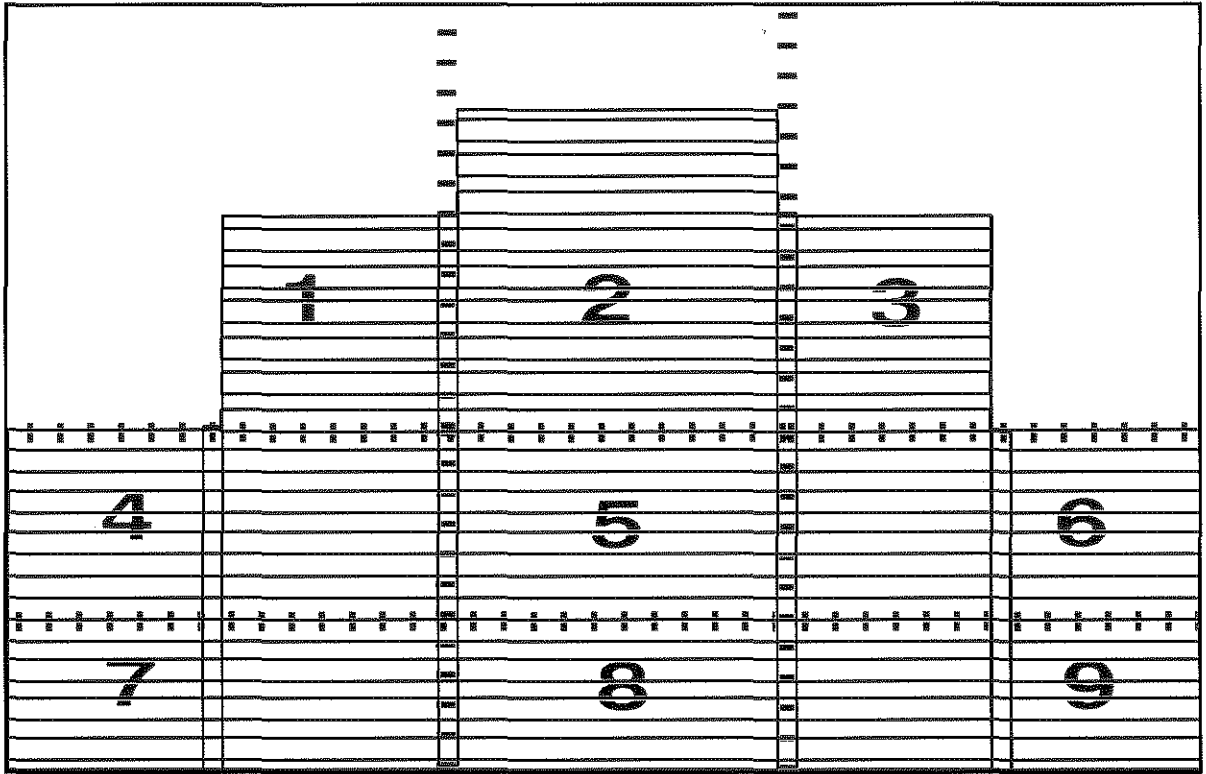

Figure 28: Metal Bin Soil Retention Wall

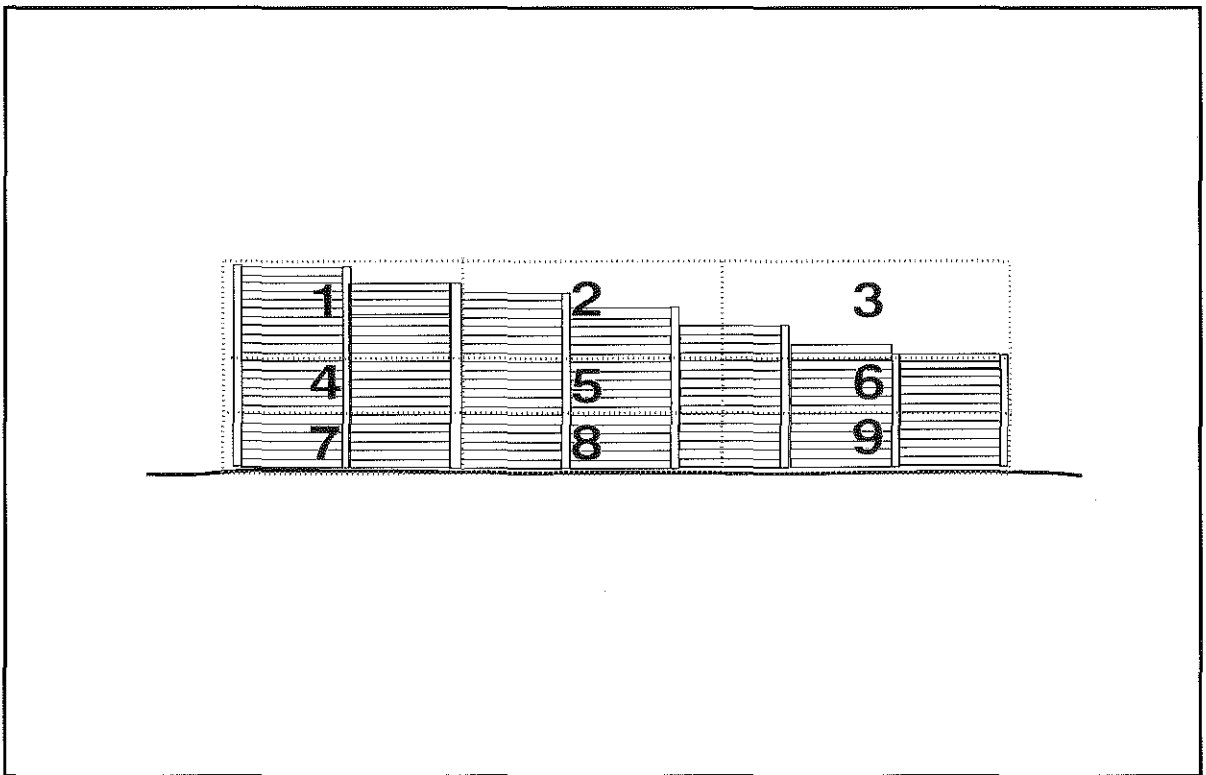

Figure 29: Metal Bin Wing Wall

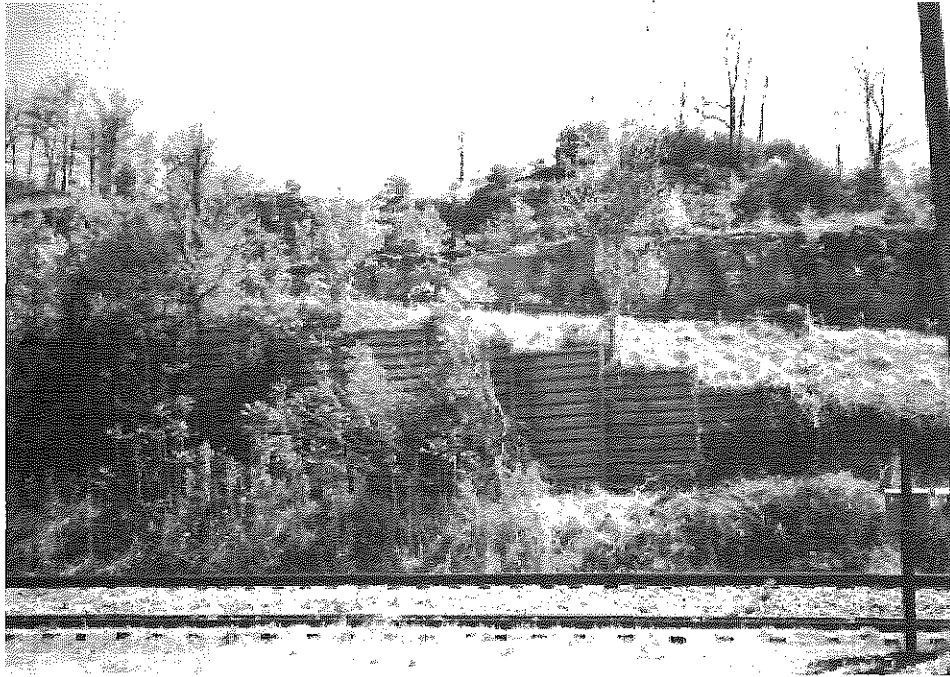

Figure 30: Metal Bin Wall located on US 25E exit ramp
(Barbourville, KY)



Figure 31: Failure in Vertical Member in Metal Bin Wall
(Barbourville, KY)



Figure 32: Failure in Vertical Member with some Lateral Displacement

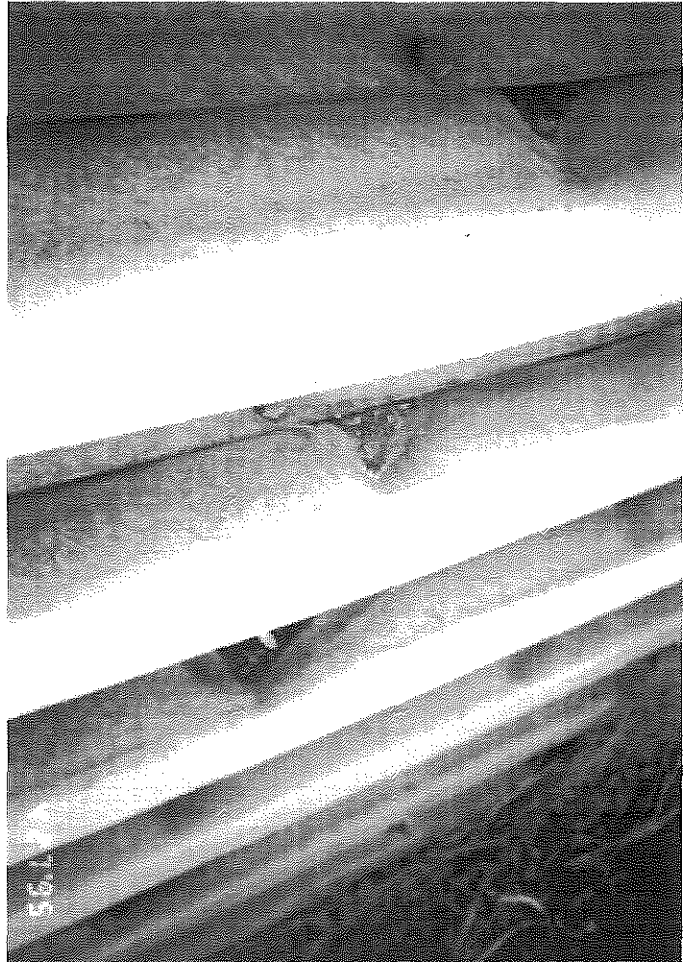

Figure 33: Bending in Horizontal Crib Members

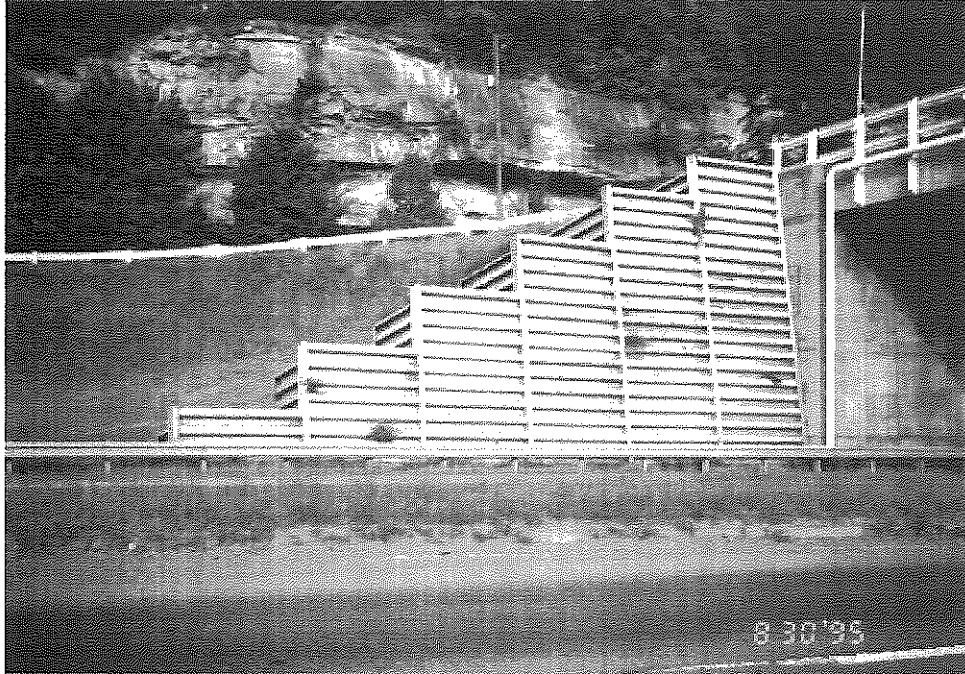

Figure 34: Metal Bin Wing Wall on US. 23 (Greenup County)

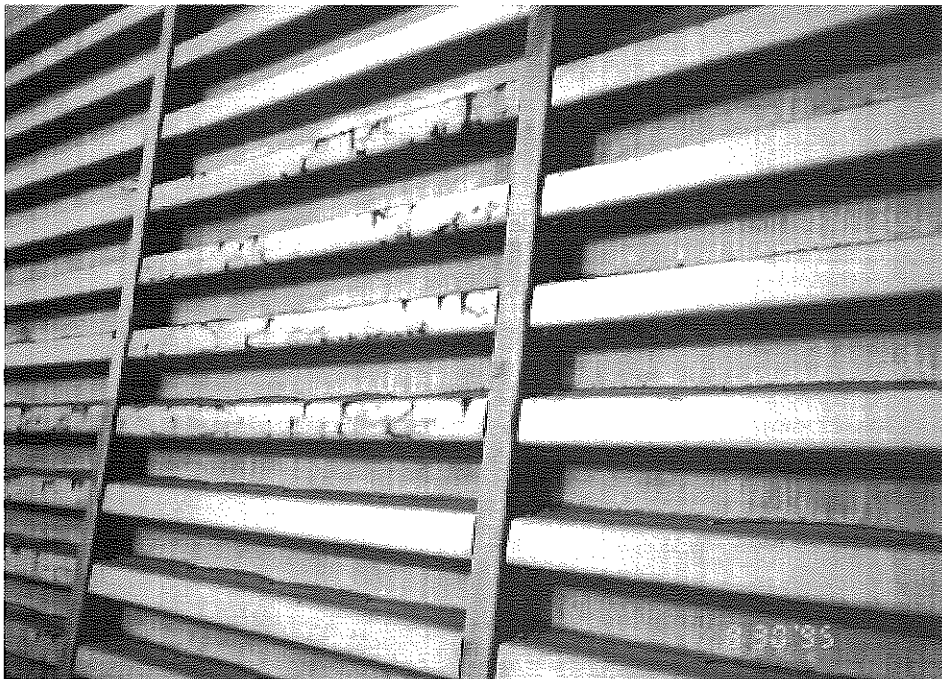

Figure 35: Rusting Observed on Face of Metal Bin Wall
(Greenup County, US. 23)

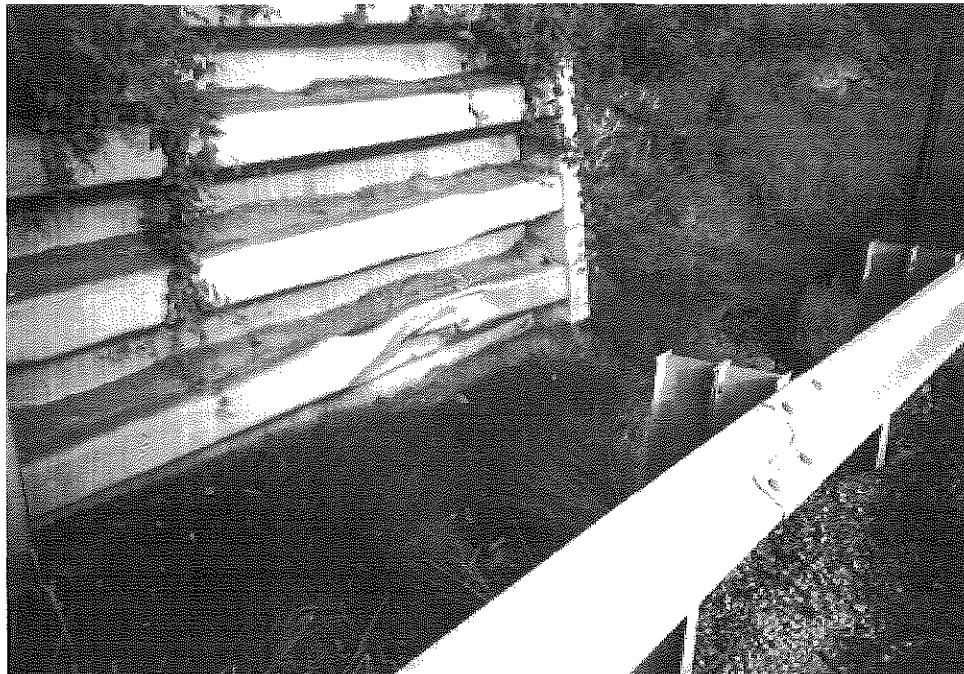

Figure 36: Possible Mower or Vehicle Damage at Base of Wall
(Greenup County, US. 23)

TABLE 5. METAL BIN WALL (Soil Retaining Wall)

LOCATION				SECTION								
				OBSERVED DISTRESS								
COUNTY	RT	MP	DIR	1	2	3	4	5	6	7	8	9
KNOX	25E				1b, 5c	1b		1b, 5c			1c, 4c, 5c	
fig. 30,31,32,33				DISTRESS OBSERVED AVG. (%)								
					1b=100%	1b=100%		1b=100%			1c=100%	
					5c=100%			5c=100%			4c=100%	
											5c=100%	

TABLE 6. METAL BIN WALL (Bridge Wing Wall)

LOCATION				SECTION								
				OBSERVED DISTRESS								
COUNTY	RT	MP	DIR	1	2	3	4	5	6	7	8	9
GREENUP	US 23	0.84	NB-EW	6a			6a	6a				
GREENUP	US 23	0.84	NB-WW	6a				6a			6a	6a,7a,9a
GREENUP	US 23	0.84	SB-EW	6a,7a	7a		6a	6a				8a
GREENUP	US 23	0.84	SB-WW				6a					9b
fig. 34,35,36				DISTRESS OBSERVED AVG. (%)								
				6a=75%	7a=25%		6a=75%	6a=75%			6a=25%	6a=25%
				7a=25%								7a=25%
												8a=25%
												9a=25%
												9b=25%

DISTRESS
 1. VERT. DISP. 3. FORWARD DISP. 5. BENDING 7. STAINING 9. DENT
 2. HORIZ. DISP. 4. VERTICAL COMPRESSION OF VERTICAL MEMBERS 6. RUSTING 8. RIPE IN METAL

SIGNIFICANCE OF DISTRESS
 A = SLIGHT
 B = MODERATE
 C = SEVERE

2.4 GABION WALLS

Five Gabion walls were visually inspected for this study. Three out of the five walls were owned by the state and two were privately owned. Each wall was divided into nine sections for analysis purposes (Figure 37). Bulging and/or sagging was observed in four out the five Gabion walls that were inspected. The location of each of the walls and observed distresses are contained in Table 7. A significant amount of bulging was observed in the Gabion wall on KY 8, Mason County. The mid-section of the wall (sections 4, 5, and 6) had bulged approximately 0.45 meter (1.5 feet) (Figure 38). Profile measurements taken from this wall on January 16, 1997 are shown in Figure 39.

Approximately 152 mm (6 inches) of sagging was observed in the I-75/I-275 Gabion wall in Kenton County (Figure 40). Profile measurements along with elevation shots across the top of the wall are shown in Figure 41. The other state-owned Gabion wall was located on I-75 at Milepost 185 and it appeared to be in good condition (Figure 42).

The two privately owned walls were located on KY 610 at Mira Station in Pike County and near US 60 in Lexington, adjacent to a Dairy Queen Restaurant. In addition to the sagging and bulging occurring with both of the private walls, moderate soil migration was observed in the Gabion wall located in Lexington.

2.4.1 Discussion

The Ky 8 Gabion wall did not appear to be tilted back 9.5 degrees or stepped back 457 mm (18 inches) in accordance with the Standard Drawing BGX-008-04 (Appendix B). In addition, the vertical joints were not offset 457 mm (18 inches) in accordance with the KY Standard Specification 742.03 which states, unless specified otherwise, the vertical joints between Gabion baskets shall be offset 457 mm from course to course (Appendix A). It should be noted that the Standard Drawing BGX-008-04 for Gabion wall construction will be deleted from the current Standard Drawings prior to April 1998. However, in the initial part of this study the drawing BGX-008-04 was still effective, and the performance of the Gabion walls observed were measured by this standard. A new design of Gabion walls has been approved, and the effective date of this new design will be April 1998.

The I-75/I-275 Gabion wall's vertical joints were not offset. However, the wall did appear to have been built with a proper set-back. Rough profile measurements taken in the field indicate the wall is currently set back 8.2 percent in one location and 7.5 percent in another. Sagging in the center of the wall may likely be contributed to settlement of the rock in the baskets and/or settlement of the foundation.

The Gabion wall on I-75 at Milepost 185 has performed well. Each succeeding course has been properly stepped back and the vertical joints were offset approximately 457 mm (18 inches). This wall appears to have been built in compliance with the Kentucky Standard Drawings.

No soil migration was observed in the state-owned Gabion walls at the time of the inspections. It appears that the state walls have been backfilled with crushed stone that prevent soil migration. However, the Dairy Queen wall indicates the possibility of soil migrating through the Gabion walls. It is suggested that a geotextile fabric be used between the Gabion wall and backfill

material if the backfill material is erodible and the crushed stone used to fill the Gabion baskets cannot prevent soil migration.

2.4.2 Recommendations

All Gabion wall construction shall be constructed in compliance with the Kentucky State Specifications and the new Standard Drawings (Appendixes A and B). The new Standard Drawing for Gabion wall construction was not available at the time this report was finalized. Consideration shall be given to placing a geotextile between the Gabion wall and the fill material if the fill material cannot be retained on the 100 millimeter (4-inch) sieve--the smallest size stone used to fill the Gabion baskets.

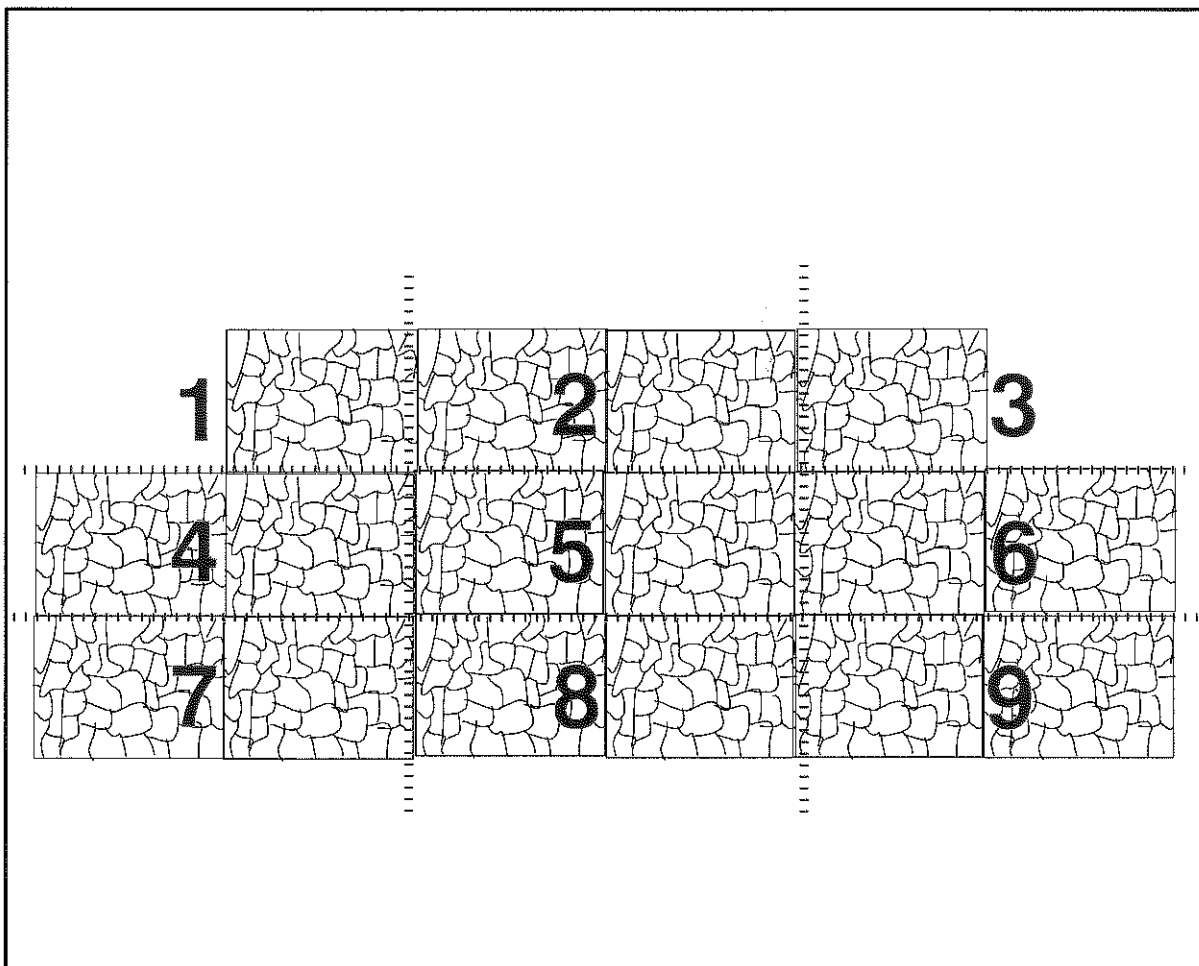

Figure 37: Gabion Wall



Figure 38: Gabion Wall on KY 8, Mason County

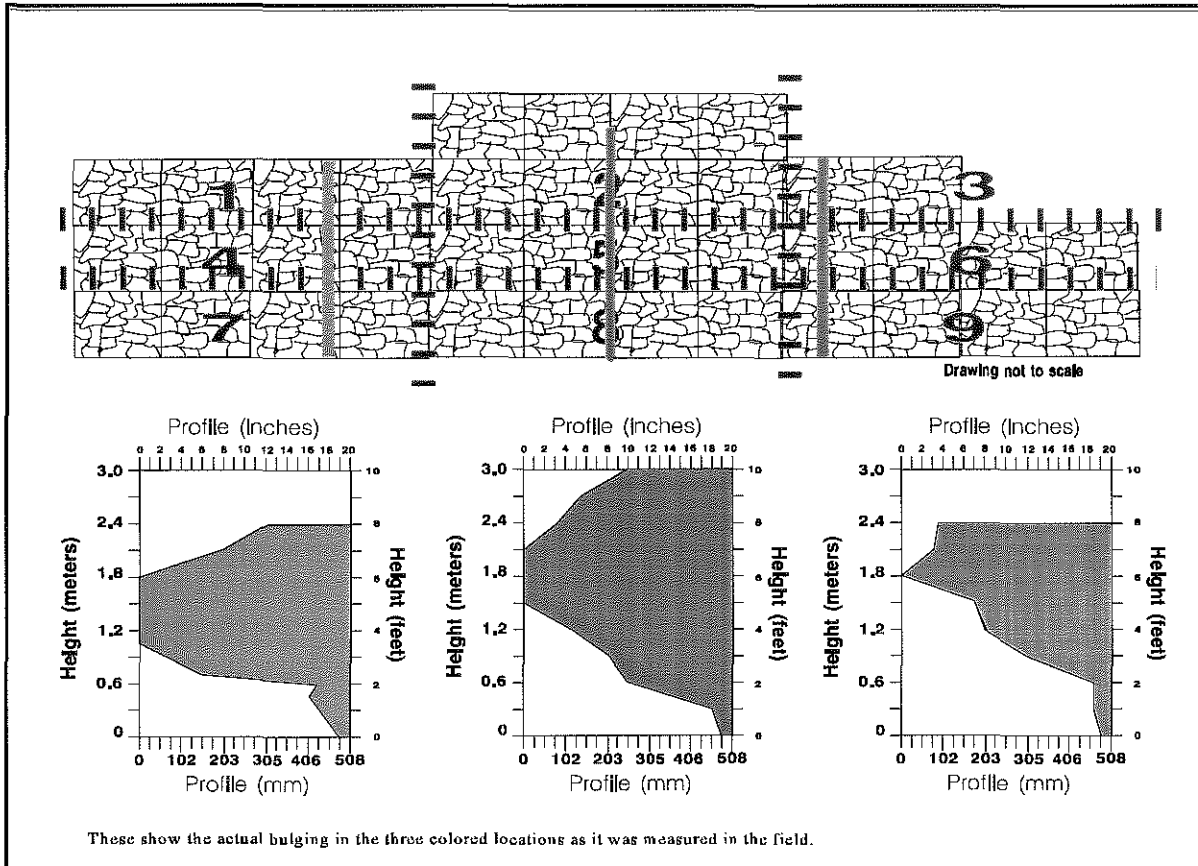

Figure 39: Profiles from KY 8 Gabion Wall

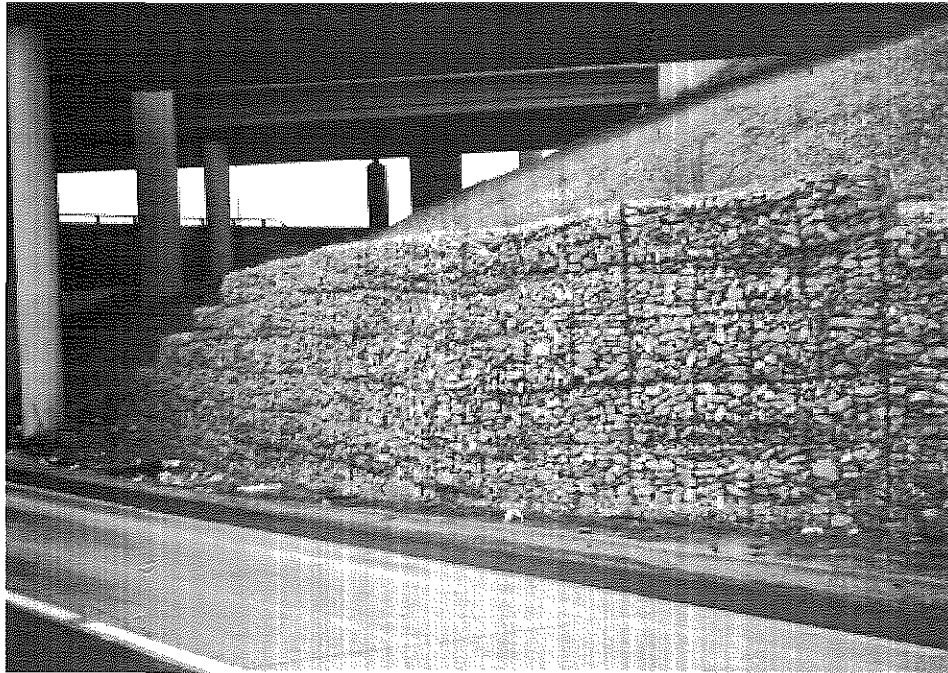

Figure 40: Gabion Wall on 1-75/I-275, Kenton County

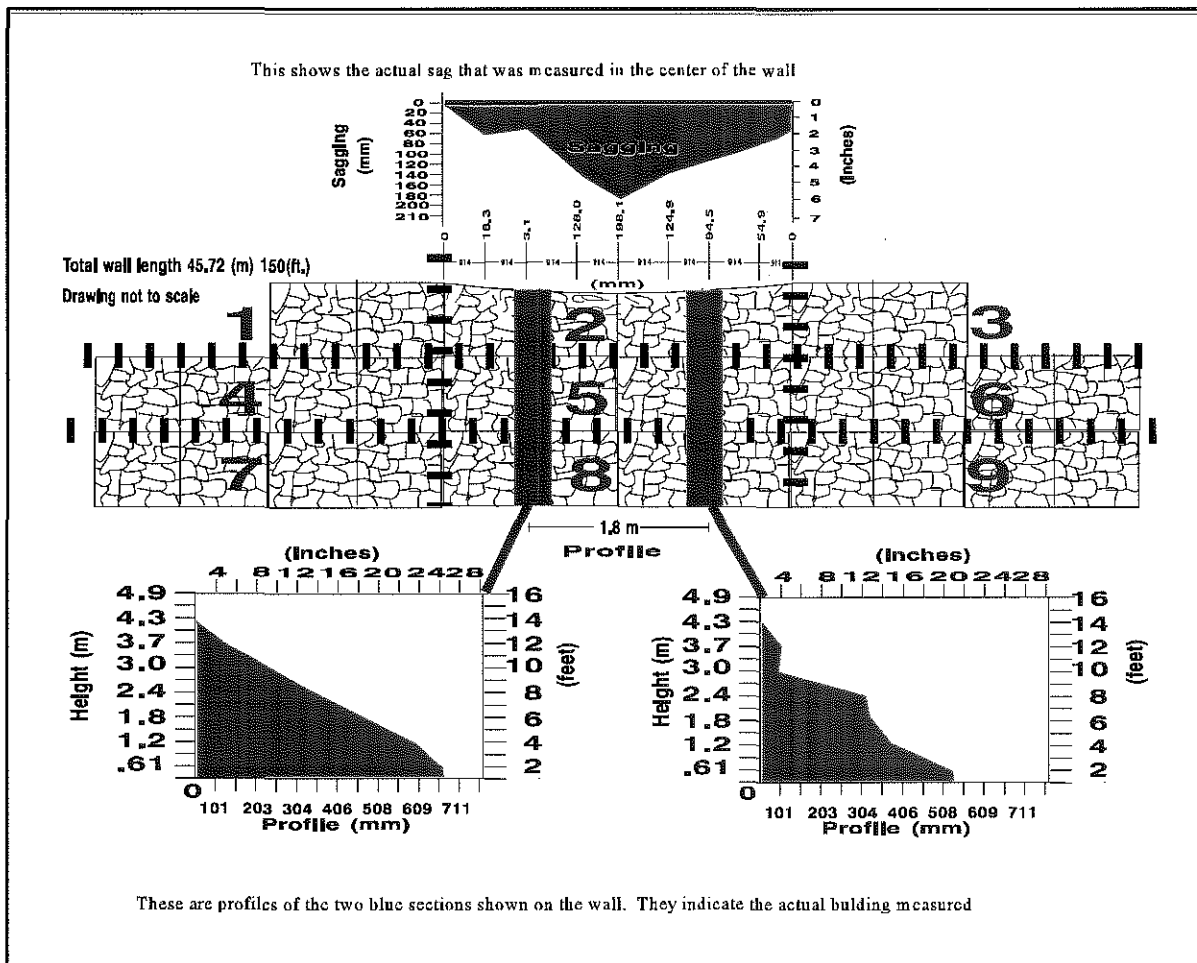

Figure 41: Profile and Sagging Observed in I-75/I-275 Gabion Wall



Figure 42: Gabion Wall on I-75, Kenton County

TABLE 7. GABION WALLS

LOCATION				SECTION								
				OBSERVED DISTRESS								
COUNTY	RT	MP	DIR	1	2	3	4	5	6	7	8	9
MASON	KY 8		W	3b,6c,7b	3b,6c,7b	3b,6c,7b	3b,6c,7b	3b,6c,7b	3b,6c,7b	3b,6c,7b	3b,6c,7b	3b,6c,7b
fig. 38												
KENTON	I-75	185	S									
fig. 42												
KENTON	I75/275	0.1	W		7b		6a	6b,7b		4b,6a	6b,7b	
fig. 40												
				DISTRESS OBSERVED AVG. (%)								
				3b=33%	3b=33%	3b=33%	3b=33%	3b=33%	3b=33%	3b=33%	3b=33%	3b=33%
				6c=33%	6c=33%	6c=33%	6a=33%	6b=33%	6c=33%	4b=33%	6b=33%	6c=33%
				7b=33%	7b=66%	7b=33%	6c=33%	6c=33%	7b=33%	6a=33%	6c=33%	7b=33%
							7b=33%	7b=66%		6c=33%	7b=66%	
										7b=33%		

DISTRESS

- 1. VERT. DISP.
- 2. HORIZ. DISP.

- 3. FORWARD DISP.
- 4. BROKEN WIRE MESH

- 5. SOIL MIGRATION
- 6. BULGING

- 7. SAGGING

SIGNIFICANCE OF DISTRESS

- A = SLIGHT
- B = MODERATE
- C = SEVERE

2.5 RIGID CONCRETE RETAINING WALLS

Fifty-one rigid concrete retaining walls were visually inspected under this study, and they were subdivided into five different categories. Thirteen of the walls were soil-retention walls, eight were vertical load-bearing bridge abutment retaining walls (breast walls), five were non-vertical load-bearing bridge abutment retaining walls, eighteen were wing walls, and seven were bridge abutment approach-fill retaining walls. Each inspected wall was divided into nine sections to help quantify repeated distress patterns. A visual diagram of each wall category and the nine sections may be viewed in Figure 43 (soil retention walls), Figure 44 (abutment and wing walls), and Figure 45 (bridge abutment approach fill walls).

On the average, each wall in the five different categories has performed well, with the exception of a few approach fill retaining walls. The majority of the distress observed with each wall type consisted of slight to moderate cracking and staining. It should be noted that the majority of the cracking observed in each wall type can be attributed to shrinkage cracking, and most of the staining observed is due to water weeping through these cracks.

2.5.1 Rigid Concrete Soil-Retention Walls

In the rigid concrete soil-retention wall evaluation, six different kinds of distress were observed: vertical displacement, forward displacement, cracking, spalling, pop-out, and staining. A statistical analysis shows that 46 percent of the walls in this category were experiencing slight to moderate staining, and 76 percent were experiencing slight to moderate cracking in all nine sections (Figure 46). A visual representation of the observed cracks may be viewed in Figures 47 and 48. The majority of the cracks observed in the rigid concrete walls originate at the weep holes and propagate toward the top of the wall. Cracking has also been observed in the key-joints along the top of the wall on KY 1065 in Jefferson County (Figures 49 and 50). Both of these photos show where the vertical key-joints have sheared due to forward displacement of the wall. It appears that these vertical joints may not have been properly designed, and with the addition of lateral soil pressures pushing out on the wall, the key-joints have failed. In addition to the six different types of distress mentioned above, the soil-retention wall on 25E in Knox County had backfill migrating out of the wall drains (Figures 51 and 52). Distress information from the inspection of the rigid concrete soil-retention walls is included in Table 8.

2.5.2 Rigid Concrete Abutment Walls with Vertical Loading

The rigid concrete abutment walls subjected to vertical loads have performed well. A statistical analysis of the distress for this wall type shows very few problems other than slight cracking and staining (Figure 53). Sections one and three, the outer top two sections, had the highest percentages of cracking recurring. The majority of the cracks observed in this particular wall type were slight in magnitude, and appeared to be shrinkage cracks. Distress information from the inspection of the rigid concrete abutment walls with vertical loading is contained Table 9.

2.5.3 Rigid Concrete Abutment Walls without Vertical Loading

The five non-vertical load bearing bridge abutment retaining walls have performed well. The only notable distress observed was slight cracking in sections one and four in three out of the five walls. Distress information from the inspection of the rigid concrete abutment walls without vertical loading is included in Table 10.

2.5.4 Rigid Concrete Wing Walls

There were very few problems observed with the rigid concrete wing walls, other than slight staining and cracking. The statistical analysis of the distress shows that the greatest number of cracks was observed in sections six and nine (Figure 54). Again, the cracks were minor and can be attributed to shrinkage cracking. Distress information from the inspection of the rigid concrete wing walls is included in Table 11.

2.5.5 Rigid Concrete Approach Fill Retaining Walls

The approach fill retaining walls have been experiencing moderate to severe cracking and forward displacement in sections one, four, and seven (Figure 55). Two walls (Figures 56 and 57) showed moderate to severe cracking in sections one and seven. The cracks in Figure 56 may be attributed to settlement of the approach. The cracks in Figure 57 may be attributed to possible freezing and thawing of water that has been seeping down through the approach fill and weeping through a construction joint. Figures 58 and 59 are photos taken from I-75 and Mall Road in Boone County. Figure 58 shows the forward displacement of the approach retaining wall in relation to the end bent (approximately 88.9 mm or 3 ½ inches). Lateral soil and water pressures have pushed the wall forward exposing a piece of conduit connecting the wall and the end bent (Figure 59). Figure 60 is an overall view of the approach fill wall and end bent at I-75 and Mall Road. The rigid wall on the opposite side of the ramp is displaced 38.1 mm or 1 ½ inches in the forward direction. Distress information from the inspection of the approach fill retaining walls is included in Table 12.

2.5.6 Discussion

The majority of the rigid concrete retaining walls have performed well, with the exception of the approach fill retaining walls. In reference to Figures 47 and 48, the majority of the cracks start at the weep holes and continue up the face of the wall. It is believed that these cracks may be attributed to shrinkage, and are not results of a design or structural flaw. These shrinkage cracks may be controlled in future wall construction by using more expansion and contraction joints. Another problem noted in the soil retention wall was the use of key-joints for the vertical construction joint (Figures 49 and 50). In this particular wall, it is believed that the key-joints have sheared due to lateral soil pressures pushing out on the wall. Dowels and water stops shall be used in place of key-joints in future wall construction. Figures 51 and 52 show where the backfill has been migrating out of the weep holes. At the time of the inspection, the design of the drainage system was not apparent, but something has allowed backfill to exit the weep holes.

The majority of the distress observed in the approach fill retaining walls has been in sections one, four, and seven. As discussed earlier, lateral soil and water pressures have forced the wall in Figures 58 and 59 to move forward. Although not required in concrete approach fill retaining walls,

consideration is to be given to reinforce the backfill. Another problem observed with this particular wall was that the grout used to fill the holes left from the form work has begun to come out (Figures 61).

2.5.7 Recommendations

Consideration is to be given to reinforcing the backfill of the approach fills if deemed necessary. The vertical joint system used on the Jefferson County wall is not to be used in the future. Instead the use of dowels and water stops shall be used. More expansion and contraction joints shall be used to control cracking, especially above weep holes. Grout used to fill holes left behind from form work shall be of a high construction grade. It is apparent that foundation drains are not fully functional on several of the wall systems that were inspected. It shall be required that backfill drains be wrapped in fabric as stated in the Kentucky Standard Specifications for drainage 206.08.02. In addition, drains shall be inspected with a miniature pipeline camera during construction in order to insure the integrity of the drainage system.

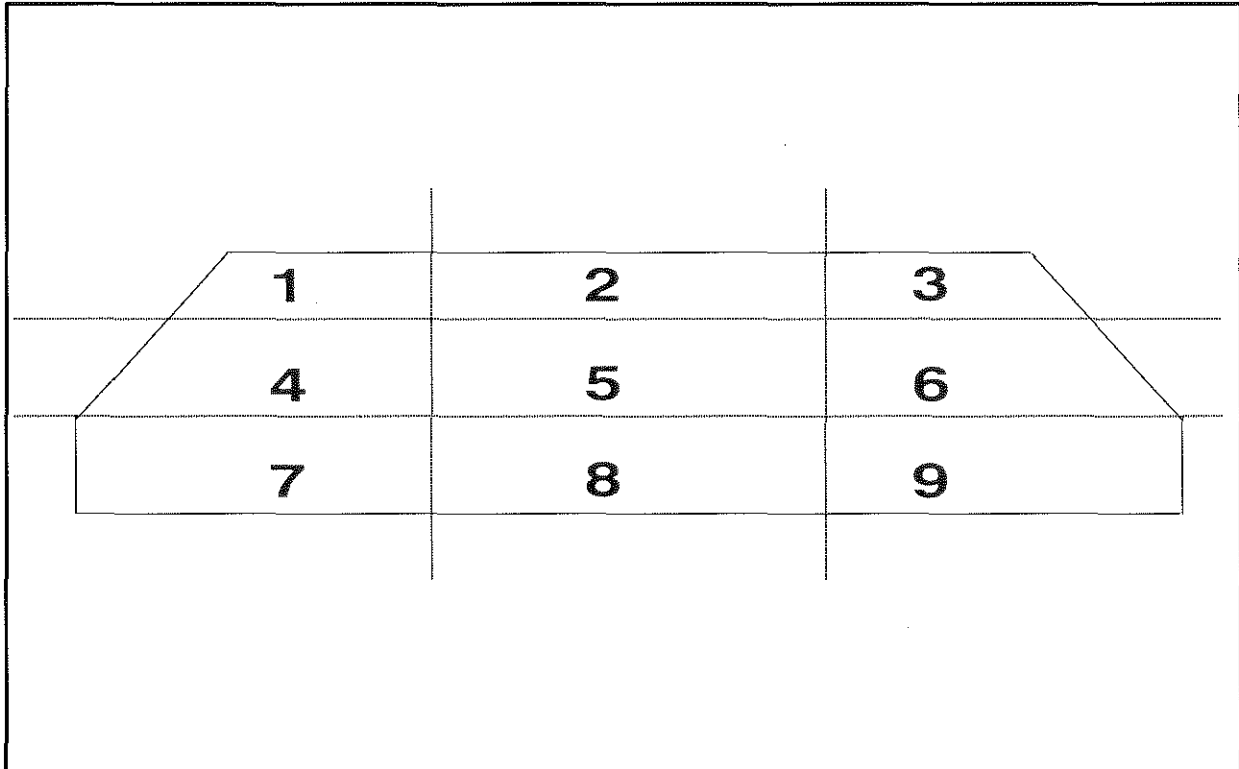

Figure 43: Rigid Concrete Soil Retention Wall

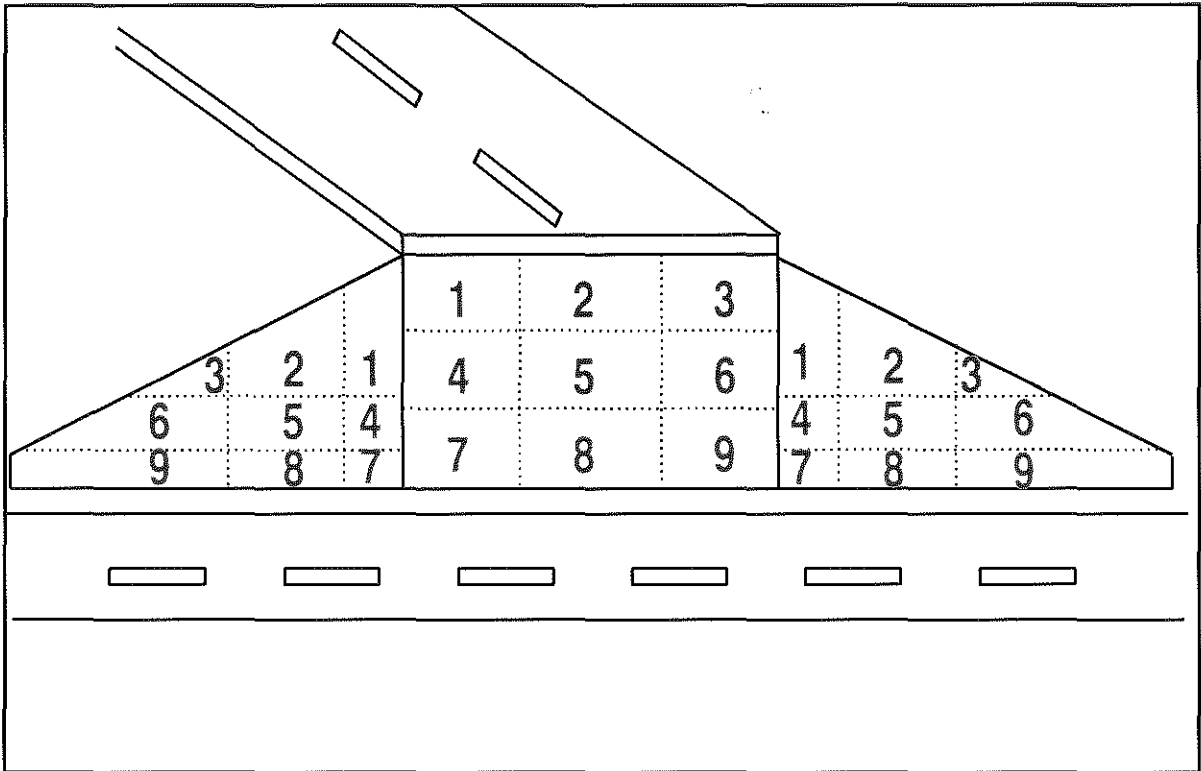

Figure 44: Rigid Abutment and Wing Retaining Walls

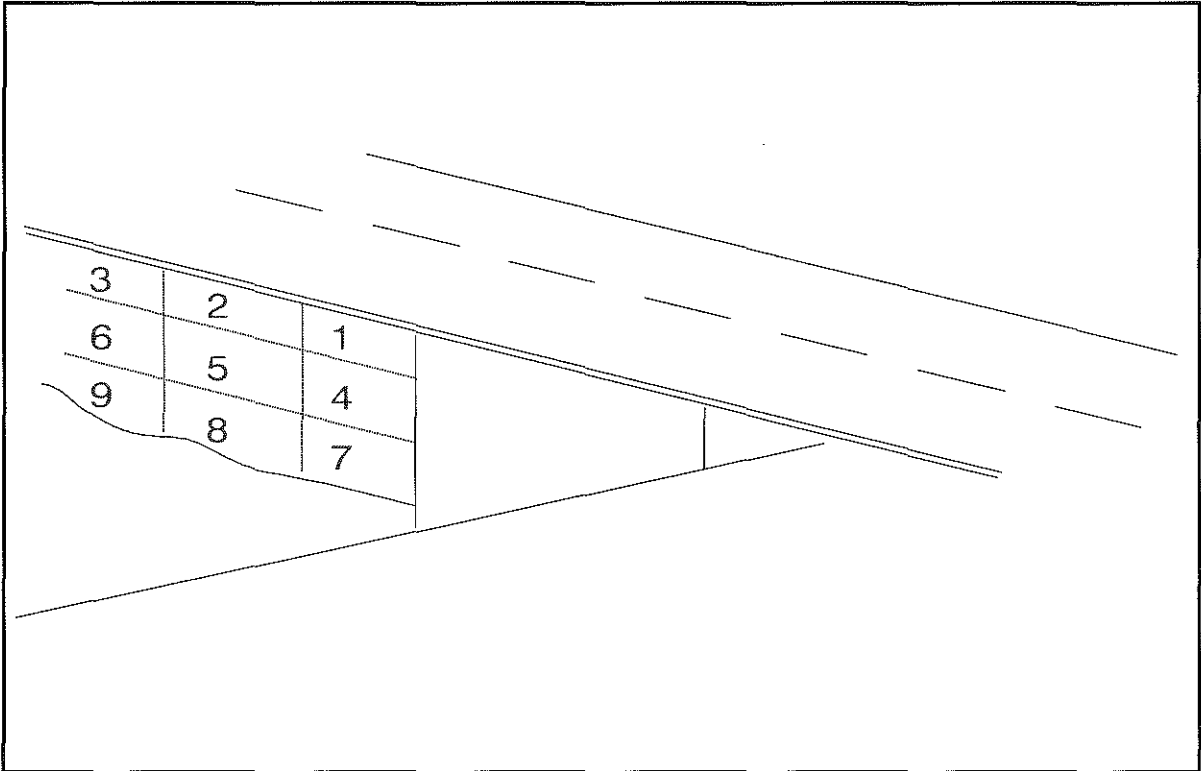

Figure 45: Rigid Retaining Wall (Approach Fill)

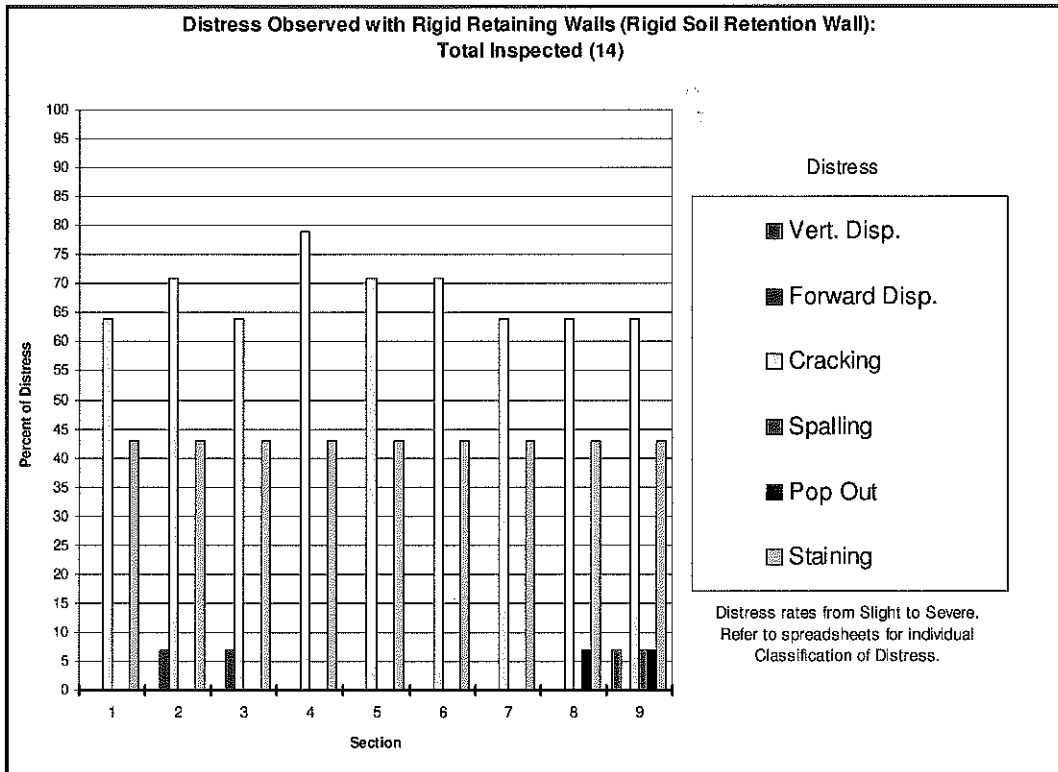

Figure 46: Observed Distress for the Rigid Soil Retention Walls

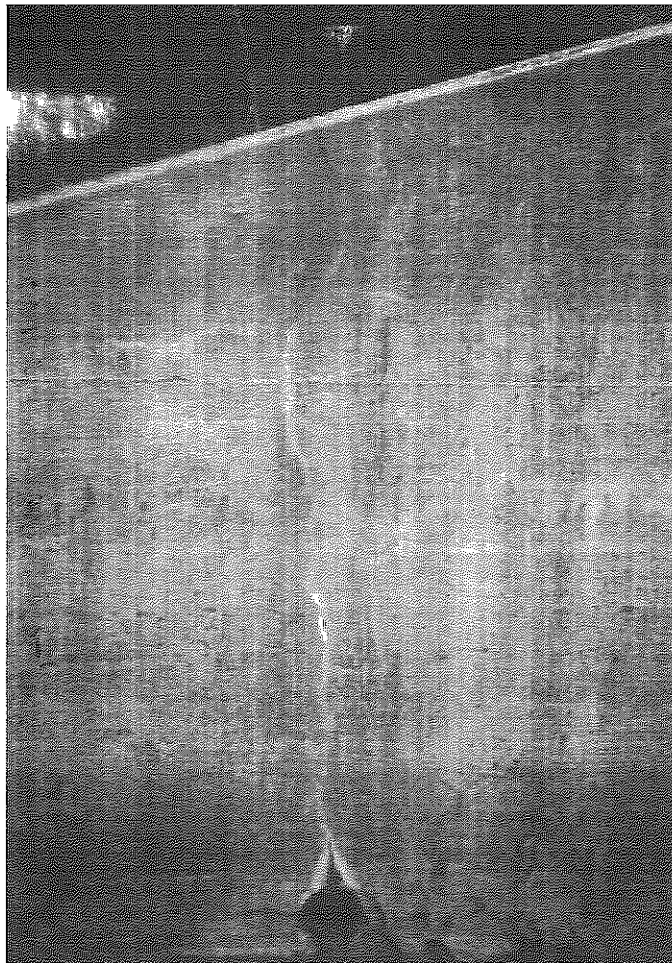

Figure 47: Cracking and Staining Stemming from Weep Hole (Jefferson County, KY 1065)

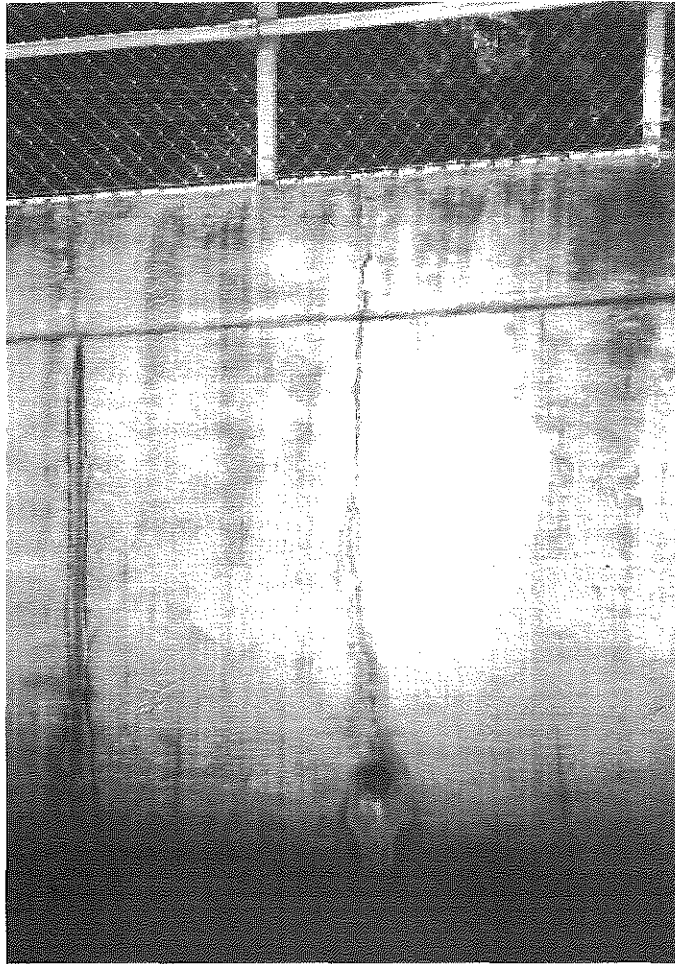

Figure 48: Cracking and Staining Stemming from Weep Hole (Floyd County)



Figure 49: Sheared Key-Joint (Jefferson County, KY 1065)

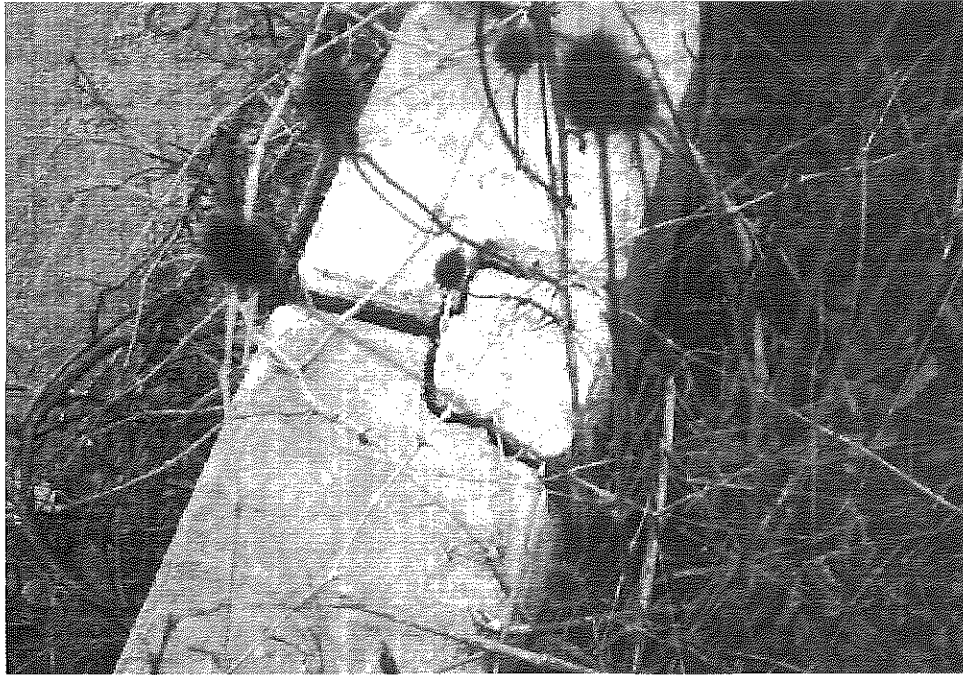

Figure 50: Sheared Key-joint (Jefferson County, KY 1065)



Figure 51: Migration of Backfill through Wall Drains (Knox County, 25E)



Figure 52: Migration of Backfill through Wall Drain
(Knox County, 25E)

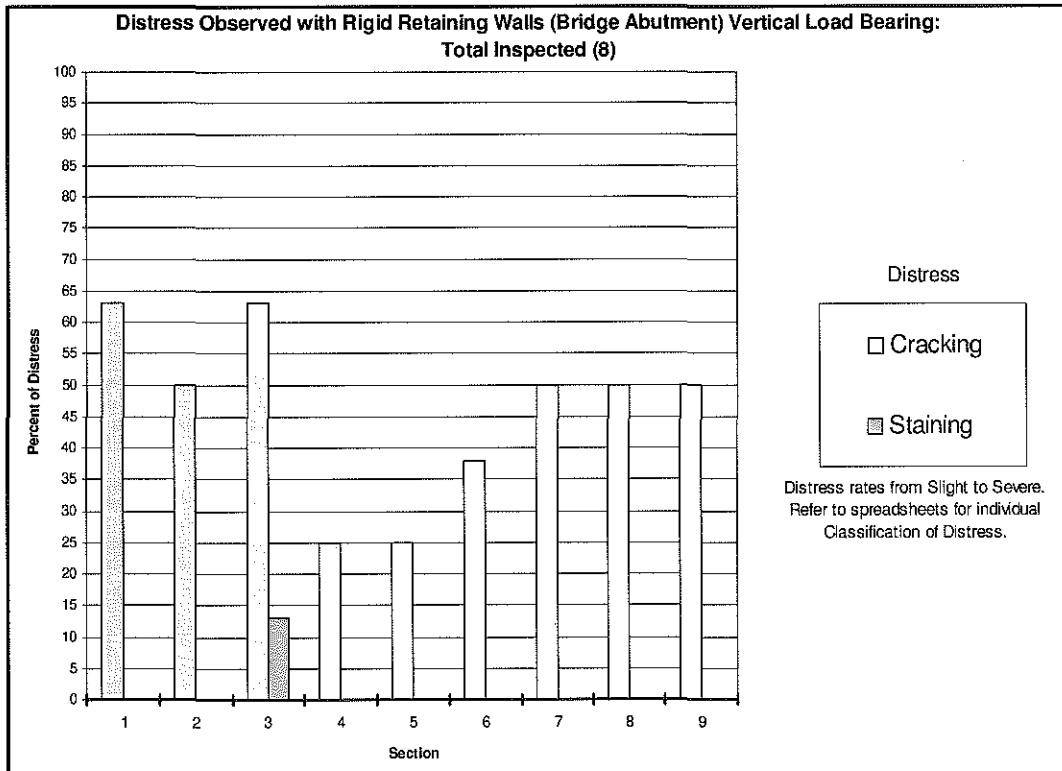

Figure 53: Observed Distress for the Rigid Bridge Abutment Walls

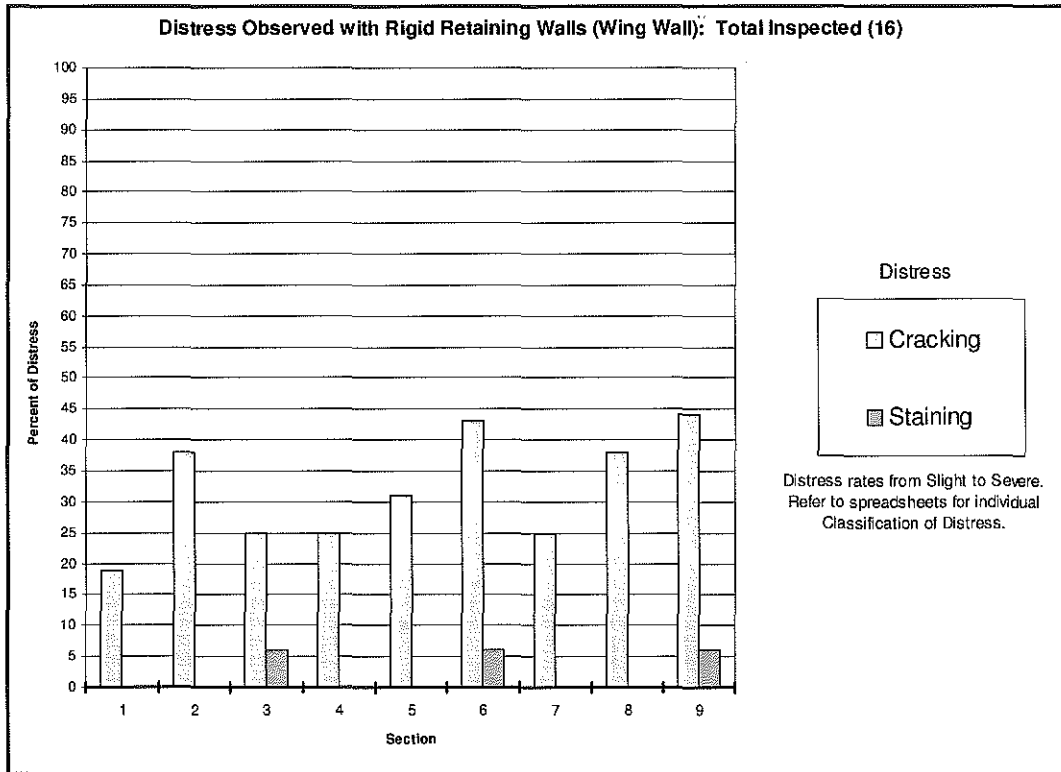

Figure 54: Observed Distress for the Rigid Wing Walls

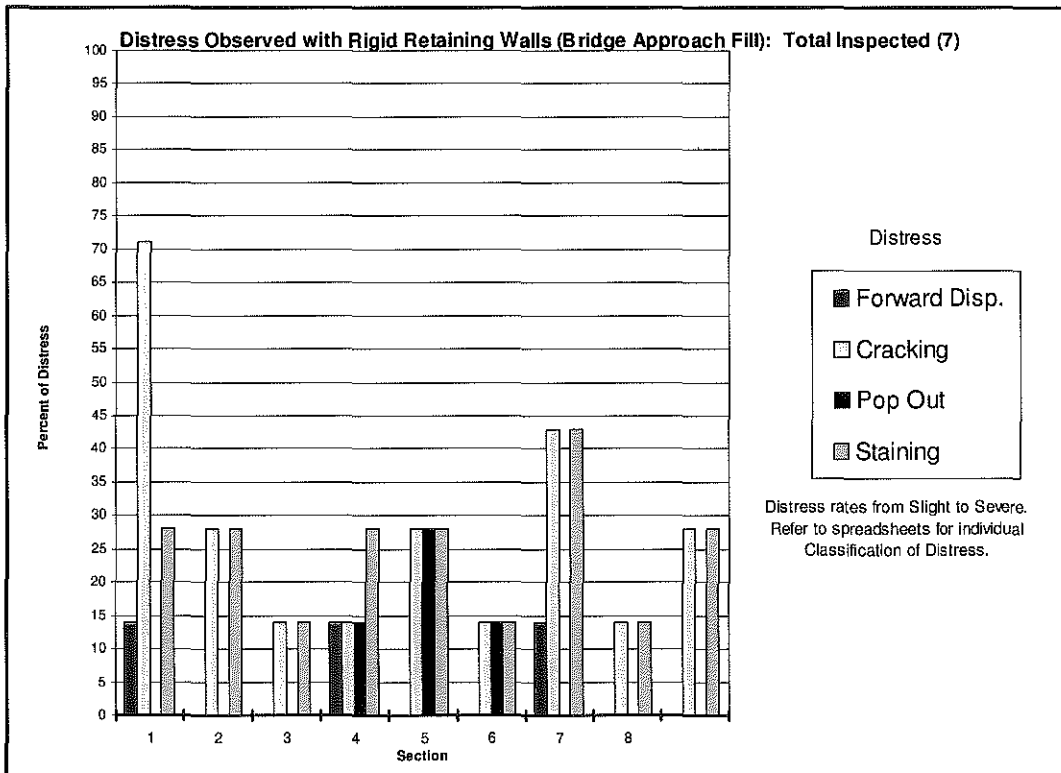

Figure 55: Observed Distress for the Rigid Approach Fill Walls



Figure 56: Moderate Cracking in Approach Fill Retaining Wall.
(Kenton County, 2nd. Street)

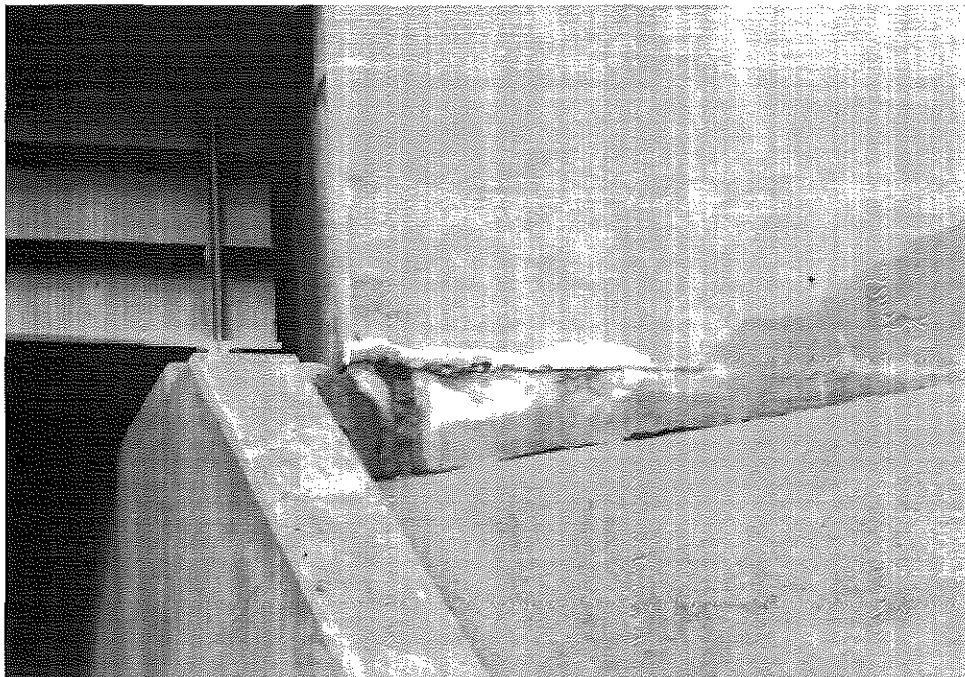

Figure 57: Water Weeping through Cracks in Approach Fill Wall
(Kenton County, I-275 East & KY 16, Milepost 78.76)

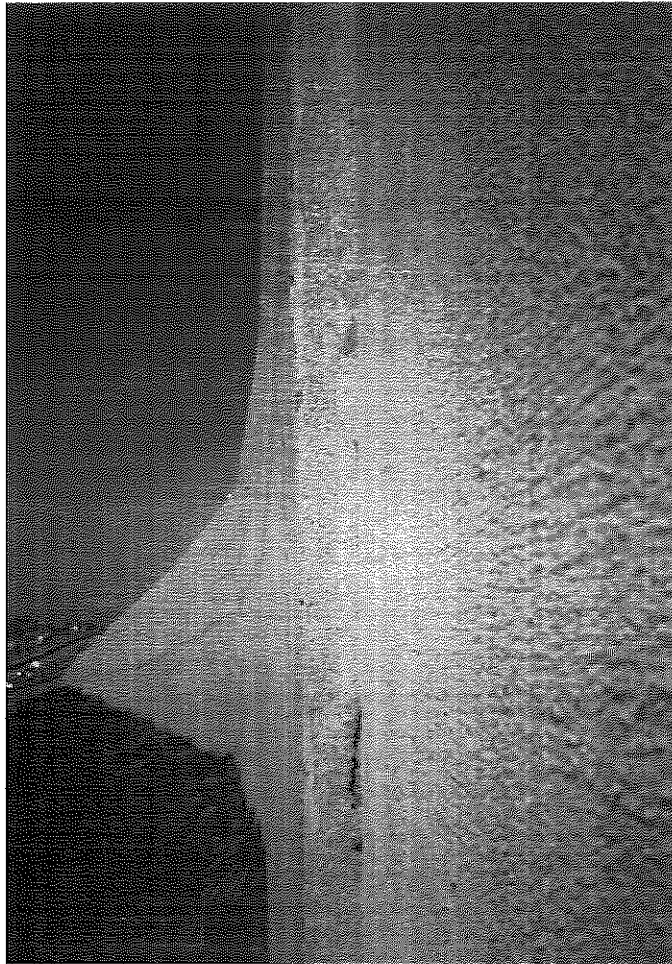

Figure 58: Forward Displacement in Approach Fill Retaining Wall (Boone County, Mall Rd.)

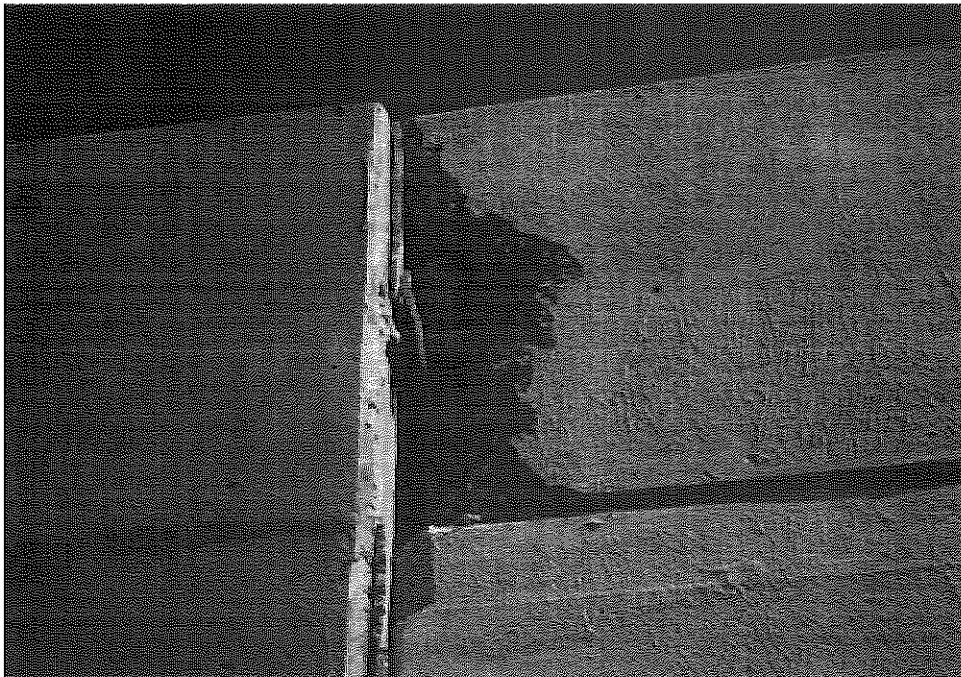

Figure 59: Broken Wall Section Caused by Forward Displacement (Boone County, Mall Rd.)

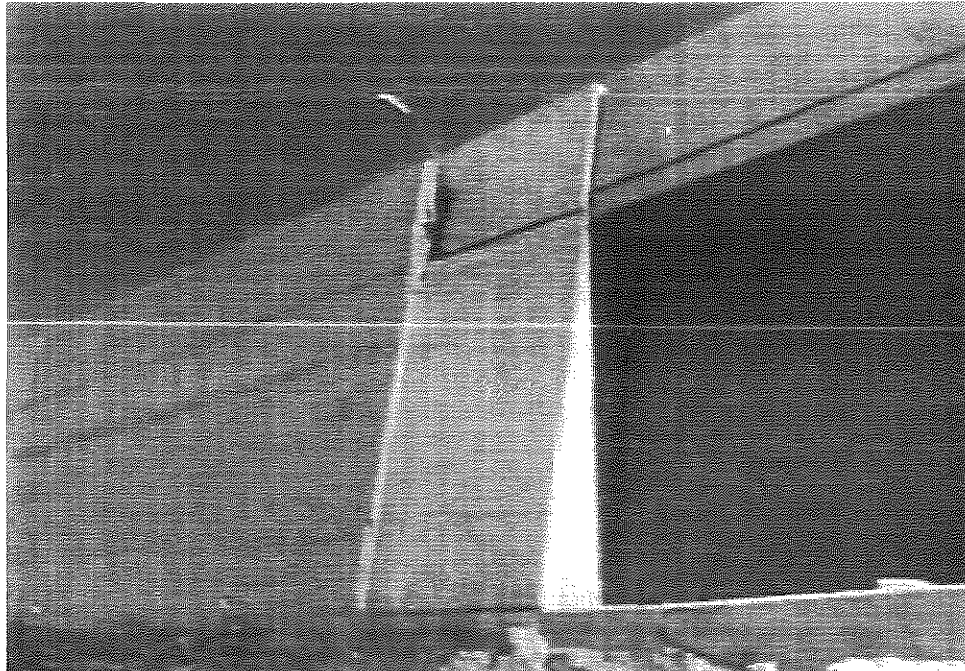

Figure 60: Overall View of Forward Displacement in Approach Fill
(Boone County, Mall Rd.)

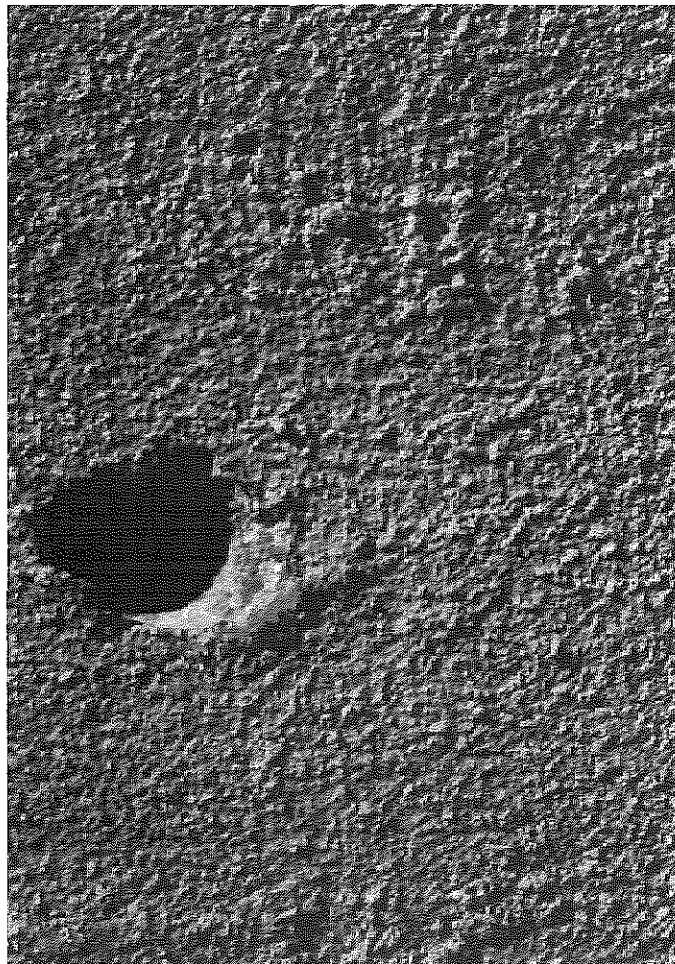

Figure 61: Hole Left Behind After Construction
(Boone County, Mall Rd.)

TABLE 8. RIGID RETAINING WALL (RIGID SOIL RETENTION WALL)

LOCATION				SECTION								
				OBSERVED DISTRESS								
COUNTY	RT	MP	DIR	1	2	3	4	5	6	7	8	9
FRANKLIN	KY RIV	8.728	NB		4a		4a	4a	4a		4a	
fig. n/a			SB				4a	4a	4a			
HARRISON	US 27		EB									
fig. n/a												
FLOYD	HAM. BL		EB #1	4a,7a	4a,7a	4a,7a	4a,7a	4a,7a	4a,7a	4a,7a	4a,7a	4a,7a
fig. 48			EB #2	4a,7a	4a,7a	4a,7a	4a,7a	4a,7a	4a,7a	4a,7a	4a,7a	4a,7a
			EB #3	4a,7a	4a,7a	4a,7a	4a,7a	4a,7a	4a,7a	4a,7a	4a,7a	4a,7a
DAVISS	56 & 500		EB		4a							
fig. n/a												
KNOX	US 25E	15.8		4a	4a	4a	4a	4a	4a	4a	4a,6a	4a,5a,6a
fig. 51,52												
DAVISS	KY 56	5	EB									
fig. n/a												
JEFFERSON	KY 1065	2.75		4b	3a	3a,4b	4b		4b	4b	4b	4b
fig. 47,49,50												
PIKE	KY 3996		EB	4a,7a	4a,7a	4a,7a	4a,7a	4a,7a	4a,7a	4a,7a	4a,7a	1a,4a,7a
fig. n/a												
PIKE	US 23	27.9	SB	4a,7a	4a,7a	4a,7a	4a,7a	4a,7a	4a,7a	4a,7a	4a,7a	4a,7a
fig. n/a												
BELL	KY 66	0.5		4a,7a	4a,7a	4a,7a	4a,7a	4a,7a	4a,7a	4a,7a	4a,7a	4a,7a
fig. n/a												
KENTON	I-75/KY 8	191.3	SB	4a	4a	4a	4a	4a	4a	4a	4a	4a
fig. n/a												

49

1. VERT. DISP.
2. HORIZ. DISP.

3. FORWARD DISP.
4. CRACKING

5. SPALLING
6. POP OUT

7. STAINING
8. BACKWARD DISP.

SIGNIFICANCE OF DISTRESS
A = SLIGHT
B = MODERATE
C = SEVERE

TABLE 8. CONTINUED. RIGID RETAINING WALL (RIGID SOIL RETENTION WALL)

				SECTION								
				1	2	3	4	5	6	7	8	9
				DISTRESS OBSERVED AVG. (%)								
				4a=57%	3a=7%	3a=7%	4a=71%	4a=71%	4a=71%	4a=57%	4a=64%	1a=7%
				4b=7%	4a=71%	4a=57%	4b=7%	7a=43%	4b=7%	4b=7%	4b=7%	4a=57%
				7a=43%	7a=43%	4b=7%	7a=43%		7a=43%	7a=43%	6a=7%	4b=7%
						7a=43%					7a=43%	5a=7%
												6a=7%
												7a=43%

DISTRESS

1. VERT. DISP.
2. HORIZ. DISP.

3. FORWARD DISP.
4. CRACKING

5. SPALLING
6. POP OUT

7. STAINING
8. BACKWARD DISP.

SIGNIFICANCE OF DISTRESS

A = SLIGHT
B = MODERATE
C = SEVERE

TABLE 9. RIGID RETAINING WALL (BRIDGE ABUTMENT) VERTICAL LOAD BEARING

LOCATION				SECTION								
				OBSERVED DISTRESS								
COUNTY	RT	MP	DIR	1	2	3	4	5	6	7	8	9
KENTON	I 275	78.764	WB	4b	4b	4b,7b		4a	4a	4a	4b	4a
fig. n/a			EB	4a	4a	4a		4a		4a	4b	4a
KENTON fig. n/a	2nd. ST.			4a		4a						
JEFFERSON	264 & 31	15.824	NB #1	4a	4a	4a	4a	4a	4a	4a	4a	4a
fig. n/a			NB #2	4a	4a	4a	4a	4a	4a	4a	4a	4a
JEFFERSON fig. n/a	264 & PL	13.491	WB									
KNOX	KY 225	11	EB #1									
fig. n/a			EB #2									
				DISTRESS OBSERVED AVG. (%)								
				4a=50%	4a=38%	4a=50%	4a=25%	4a=25%	4a=38%	4a=50%	4a=25%	4a=50%
				4b=13%	4b=13%	4b=13%					4b=25%	
						7b=13%						

DISTRESS
 1. VERT. DISP.
 2. HORIZ. DISP.

3. FORWARD DISP.
 4. CRACKING

5. SPALLING
 6. POP OUT

7. STAINING
 8. BACKWARD DISP.

SIGNIFICANCE OF DISTRESS
 A = SLIGHT
 B = MODERATE
 C = SEVERE

TABLE 10. RIGID RETAINING WALL (BRIDGE ABUTMENT) NON-VERTICAL LOAD BEARING

LOCATION				SECTION								
COUNTY	RT	MP	DIR	1	2	3	4	5	6	7	8	9
KENTON	I 75	171	NB									
fig. n/a			SB									
HENDERSO N fig. n/a	351 & 41		WB	4a			4a			4a		
BOONE fig. n/a	I-75	180.6	SB	4a	4a,6a	4a,6a	4a	4a,6a	4a,6a,7a			
BOONE fig. n/a	I-75	181.1	NB	4a,8a	8a	8a	8a	8a	8a	8a	8a	8a
				DISTRESS OBSERVED AVG. (%)								
				4a=60%	4a=20%	4a=20%	4a=40%	4a=20%	4a=20%	4a=20%	8a=20%	8a=20%
				8a=20%	6a=20%	6a=20%	8a=20%	6a=20%	6a=20%	8a=20%		
					8a=20%	8a=20%		8a=20%	7a=20%			
									8a=20%			

DISTRESS

- 1. VERT. DISP.
- 2. HORIZ. DISP.

- 3. FORWARD DISP.
- 4. CRACKING

- 5. SPALLING
- 6. POP OUT

- 7. STAINING
- 8. BACKWARD DISP.

SIGNIFICANCE OF DISTRESS

- A = SLIGHT
- B = MODERATE
- C = SEVERE

TABLE 11. RIGID RETAINING WALL (WING WALL)

LOCATION				SECTION								
				OBSERVED DISTRESS								
COUNTY	RT	MP	DIR	1	2	3	4	5	6	7	8	9
HENDERSON	351 & 41		WB #1							4a		
fig. n/a			WB #2									
JEFFERSON	264 & PL	13.491	WB #1	4a	4a	4a	4a	4a	4a	4a	4a	4a
fig. n/a			WB #2	4a	4a	4a	4a	4a	4a	4a	4a	4a
JEFFERSON	264 & PL	13.491	EB #1		4a	4a,7a		4a	4a,7a		4a	4a,7a
fig. n/a			EB #2	4a	4a	4a	4a	4a	4a	4a	4a	4a
KENTON	2nd. ST.		#1									
fig. n/a			#2									
KENTON	I 275	78.764	WB #1		4b			4b	4b		4b	4b
fig. n/a			WB #2									
KENTON	I 275	78.764	EB #1		4a				4a			4a
fig. n/a			EB #2						4b			4b
WHITLEY	312	0	NB #1									
fig. n/a			NB #2				4b				4b	
WHITLEY	312	0	SB #1									
fig. n/a			SB #2									

DISTRESS

- 1. VERT. DISP.
- 2. HORIZ. DISP.

- 3. FORWARD DISP.
- 4. CRACKING

- 5. SPALLING
- 6. POP OUT

- 7. STAINING
- 8. BACKWARD DISP.

SIGNIFICANCE OF DISTRESS

- A = SLIGHT
- B = MODERATE
- C = SEVERE

TABLE 11. CONTINUED. RIGID RETAINING WALL (WING WALL)

LOCATION				SECTION								
				OBSERVED DISTRESS								
				1	2	3	4	5	6	7	8	9
				DISTRESS OBSERVED AVG. (%)								
				4a=19%	4a=31%	4a=25%	4a=19%	4a=31%	4a=31%	4a=25%	4a=25%	4a=31%
					4b=6%	7a=6%	4b=6%	4b=6%	4b=13%		4b=13%	4b=13%
									7a=6%			7a=6%

DISTRESS

- 1. VERT. DISP.
- 2. HORIZ. DISP.

- 3. FORWARD DISP.
- 4. CRACKING

- 5. SPALLING
- 6. POP OUT

- 7. STAINING
- 8. BACKWARD DISP.

SIGNIFICANCE OF DISTRESS

- A = SLIGHT
- B = MODERATE
- C = SEVERE

Table 12. RIGID RETAINING WALL (APPROACH FILL)

LOCATION				SECTION								
COUNTY	RT	MP	DIR	1	2	3	4	5	6	7	8	9
KENTON fig. 56	2 nd. St.			4c								
KENTON fig. 57	I-275	78.76	nb/es #1	4b,7c								
			nb/es #2	4b								
			sb/ws #1	4b								
			sb/ws #2							4b,7b		
BOONE fig. 58,59,60,61	I-75	181.1	nb/ws	3b,4b,7a	4b,7a		3b,4b,7a	4a,6a,7a		3b,4a,7a	4a,7a	4a,7b
			nb/es		4a,7a	4a,7a	6a,7a	4a,6a,7b	4a,6a,7b	4a,7a		4a,7a
				DISTRESS OBSERVED AVG. (%)								
				3b=14%	4a=14%	3b=14%	3b=14%	4a=28%	4a=14%	3b=14%	4a=14%	4a=28%
				4b=57%	4b=14%	4a=14%	4b=14%	6a=28%	6a=14%	4a=28%	7a=14%	7a=14%
				4c=14%	7a=28%	7a=14%	6a=14%	7a=14%	7b=14%	4b=14%		7b=14%
				7a=14%			7a=28%	7b=14%		7a=28%		
				7c=14%						7b=14%		

DISTRESS

- 1. VERT. DISP.
- 2. HORIZ. DISP.

- 3. FORWARD DISP.
- 4. CRACKING

- 5. SPALLING
- 6. POP OUT

- 7. STAINING
- 8. BACKWARD DISP.

SIGNIFICANCE OF DISTRESS

- A = SLIGHT
- B = MODERATE
- C = SEVERE

2.6 KEYSTONE (MODULAR BLOCK) RETAINING WALL

Keystone modular block retaining structures are relatively new to the construction industry. To date, this type of structure has not been used by the Kentucky Department of Highways. Transportation Personnel did request that Center personnel evaluate the performance of some of the private Keystone walls built in the state. Two Keystone modular block retaining walls were evaluated. The first wall evaluated was located on Richmond Road at the Walmart Department Store (Figure 62), and the second wall was located behind Days Inn at Richmond Road and I-75 (Figure 63). The Walmart wall is approximately 9 meters (30 ft.) high and 125 meters (410 ft.) long. Significant distress was observed in several locations along the face of the wall. Distress included: cracking (Figure 64), sliding (Figures 65a and 65b), bulging, migration of backfill between blocks (Figure 66) and settlement behind the retaining structure. City engineers that were knowledgeable of the construction indicated the wall is seated on bedrock and backfilled with a native soil.

The Days Inn wall is approximately 6 meters (20 ft.) high. The wall appears to be in good condition.

2.6.1 Discussion

It is apparent that post settlement has occurred in the Walmart Wall. It is also apparent that the storm drains for the parking lot on top of the wall are no longer fully functional. It is likely the backfill is becoming saturated. Movement in the blocks is also allowing the crushed stone drainage layer located directly behind the wall to migrate between the blocks. A private consultant for Walmart is currently taking bids to install slope inclinometers and install monitoring points to evaluate further movement in the wall system.

The Keystone modular block system has been used in several other areas throughout the country. The system is relatively easy to construct, has a pleasing appearance, and is likely a stable wall system under the right design and construction conditions.



Figure 62: Keystone Block Wall, Richmond Rd. Lexington

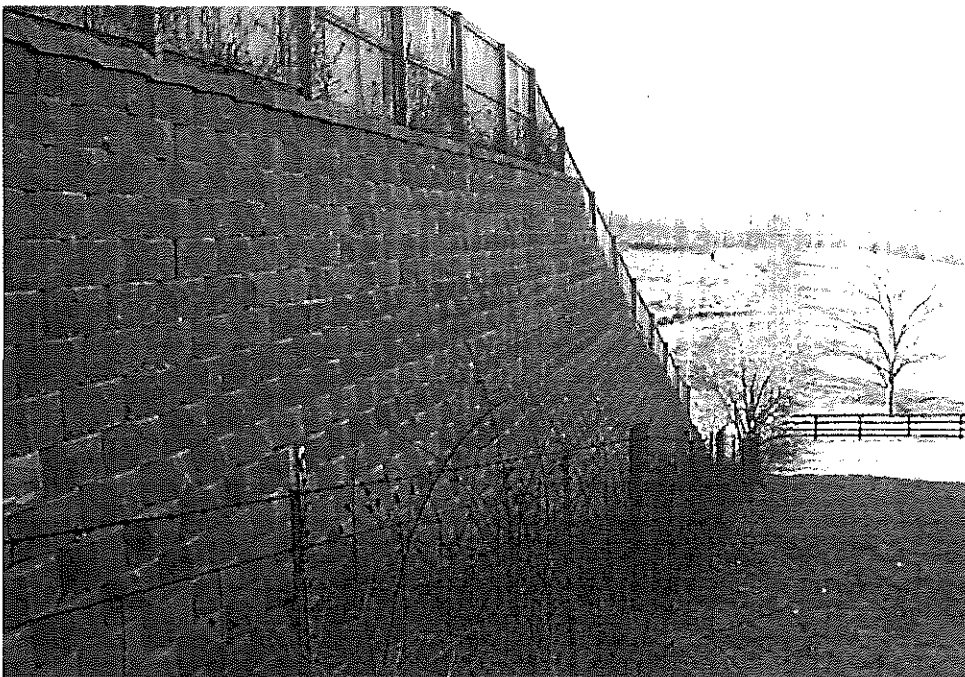

Figure 63: Keystone Block Wall, Days Inn at Richmond Rd & I-75,
Lexington

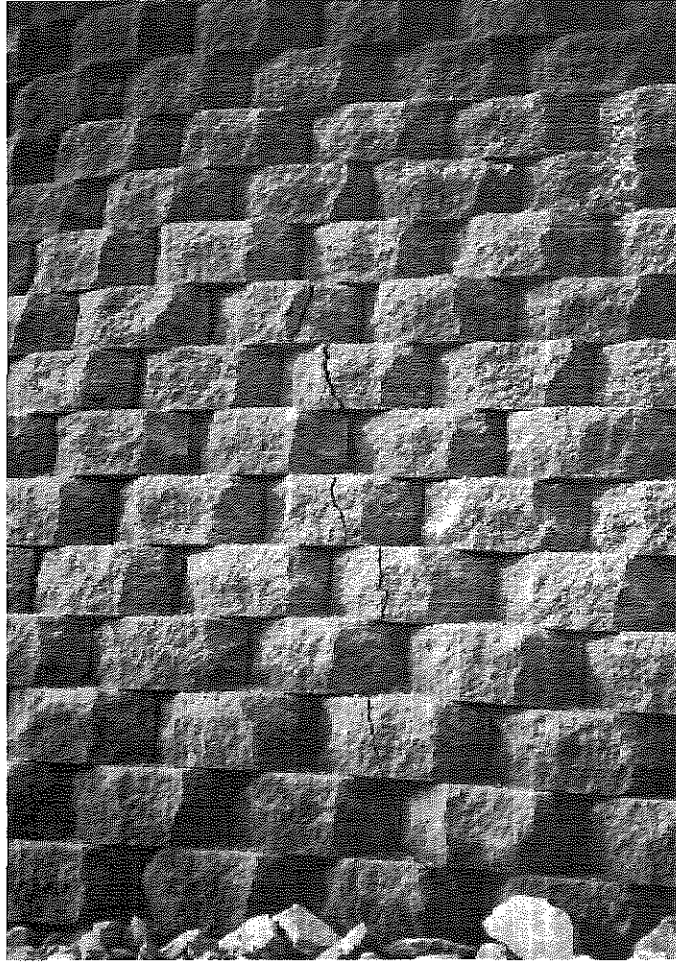

Figure 64: Cracks in Keystone Blocks



Figure 65a: Forward Displacement between Rows (sliding)



Figure 65b: Forward Displacement (4 to 5 inches)



Figure 66: Migration of Backfill between Blocks

2.7 TIEDBACK WALLS

Ten tiedback walls were visually inspected in this study. Of the ten walls inspected, six had a concrete cast-in-place wall placed in front of the tiedback wall, and four had an exposed timber lagging facing. To evaluate the performances of the tiedback walls, it will be necessary to look at the walls individually, due to differences in design. Each wall was divided into nine sections to help quantify repeated distress patterns.

The four walls with timber lagging facing were similar in some aspects and different in others. Two of the tiedback walls used clips attached to the front flanges of the steel piles to hold the lagging in place, and the other two tiedback walls had the timber lagging placed behind the front flanges of the H-Piles. The two tiedback walls that used clips to hold the lagging in place were in Campbell County, US 27 (Figure 67) and Carroll County, KY 227 (Figure 68). Both walls have experienced a significant amount of distress. A large number of the lagging clips on the KY 227 tiedback wall have broken away from the H-piles, and consequently the timber lagging has started to displace (Figures 69 and 70). Severe rusting has started to degrade both the timber lagging clips and whalers on the US 27 tiedback wall (Figures 71 and 72). The majority of the rusting can be attributed to poor performance of the tape coat mastic applied for corrosion protection. An additional problem that has been observed with the tiedback wall on US 27 was the erosion of the backfill on top of the wall (Figure 73). Distress information for the tiedback walls with timber lagging clips is included in Table 13.

The two tiedback walls that had the timber lagging placed between the webs of the H-piles have performed well. The wall in Leslie County on KY 118 has one single tieback per whaler (Figure 74), and the wall in Greenup County on US 23 is tied directly to the H-piles (Figure 75). Both walls are relatively new and have experienced only minor distress at this time. The only noticeable distress observed in either wall was slight displacement in a few of the timber laggings on the US 23 tiedback wall (Figure 76). Distress information for the tiedback walls without ties is included in Table 14.

The majority of the treated timbers (lagging) mentioned in both groups above have performed well. Weathering of the lagging seems to not have decreased the serviceability of any of the observed tiedback walls.

The six concrete cast-in-place walls have performed well. The only recurring distress noted in two-thirds of these walls was slight cracking and staining. Other signs of distress such as pavement distress or slide failure in the vicinity of the tiedback wall were not noticeable at the time of the inspection. Distress information for the concrete cast-in-place tiedback walls is included in Table 15.

2.7.1 Discussion

The majority of the tiedback walls have performed well with the exception of the two tiedback walls that used clips attached to the front flanges of the steel-piles to hold the lagging in place. In both of these walls (Figures 70 and 71), it is apparent that the timber lagging clips have rusted in all nine sections. In some areas, the lagging clips have broken away from the H-piles due

either to rusting or poor welding. In areas where the lagging clips were broken, the timber lagging has dropped down or bowed out(Figures 69 and 70). Once the lagging moves forward, the retained backfill is allowed to migrate through the wall. Figure 73 shows erosion on top of the tiedback wall. This erosion coupled with displaced lagging has the potential of creating a cavity behind the face of the wall.

The cast-in-place tiedback walls have performed well. It is believed that if the cast-in-place tiedback wall is constructed properly that its serviceability will outlast that of the exposed timber lagging tiedback wall.

2.7.2 Recommendations

In future tiedback wall construction, the method of using clips to hold timber lagging in place shall not be used. Walls that have used this method have been in service for approximately 13 years and are in need of immediate maintenance. The use of tape coat mastic for a preventive against corrosion shall not be used. Instead, consideration is to be given to all exposed steel used in tiedback walls to be oversized or painted in accordance with the requirements for new steel bridges in Kentucky.

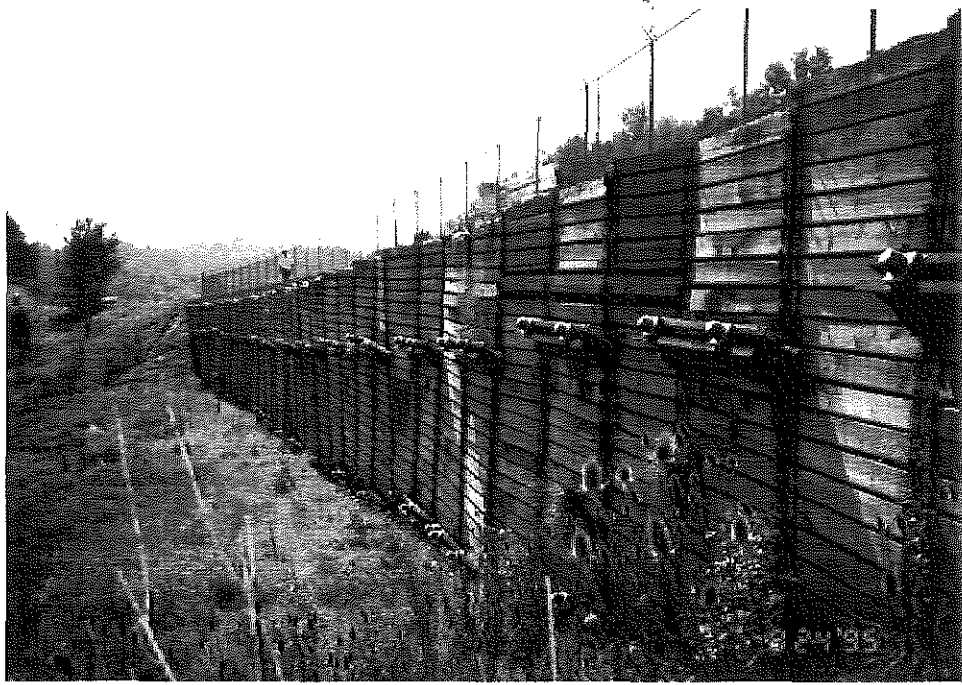

Figure 67: Tiedback Wall with Timber Lagging Ties (Campbell County, US27)

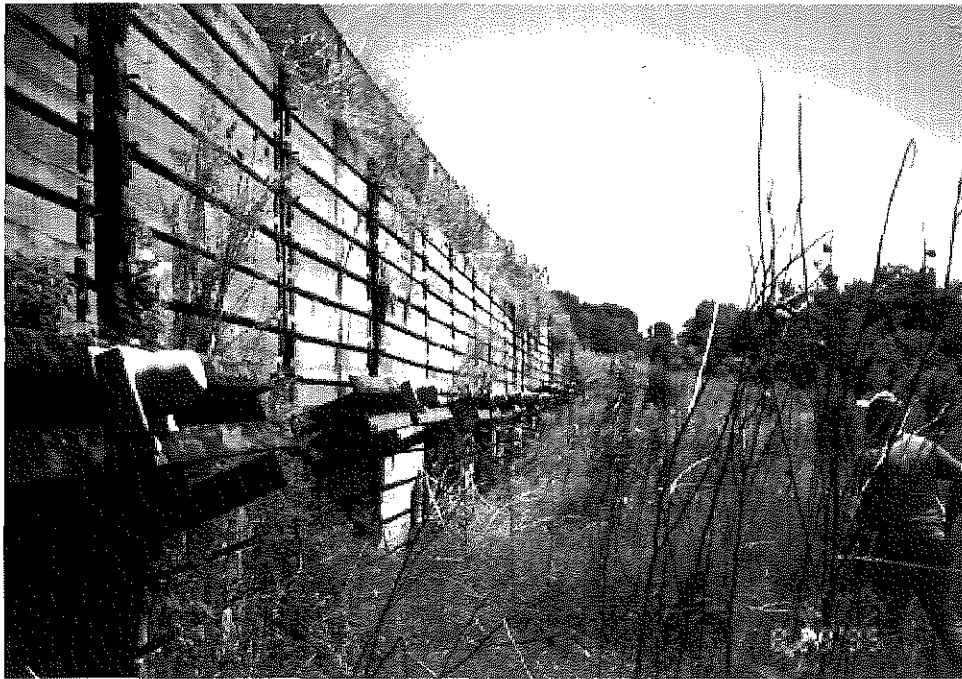

Figure 68: Tiedback Wall with Timber Lagging Ties (Carroll County, KY 227)



Figure 69: Displaced Timber Lagging Ties (Carroll County, KY 227)



Figure 70: Broken Lagging Ties (Carroll County, KY 227)



Figure 71: Rusted Timber Lagging Ties (Campbell County, US 27)

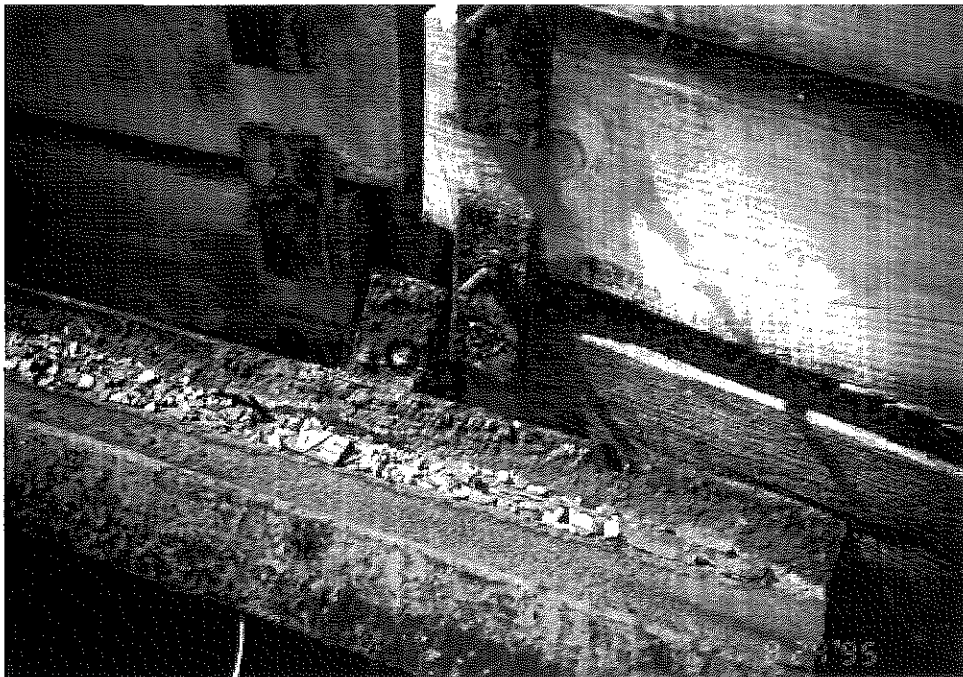

Figure 72: Rusted Whaler and Timber Lagging Ties
(Campbell County, US 27)

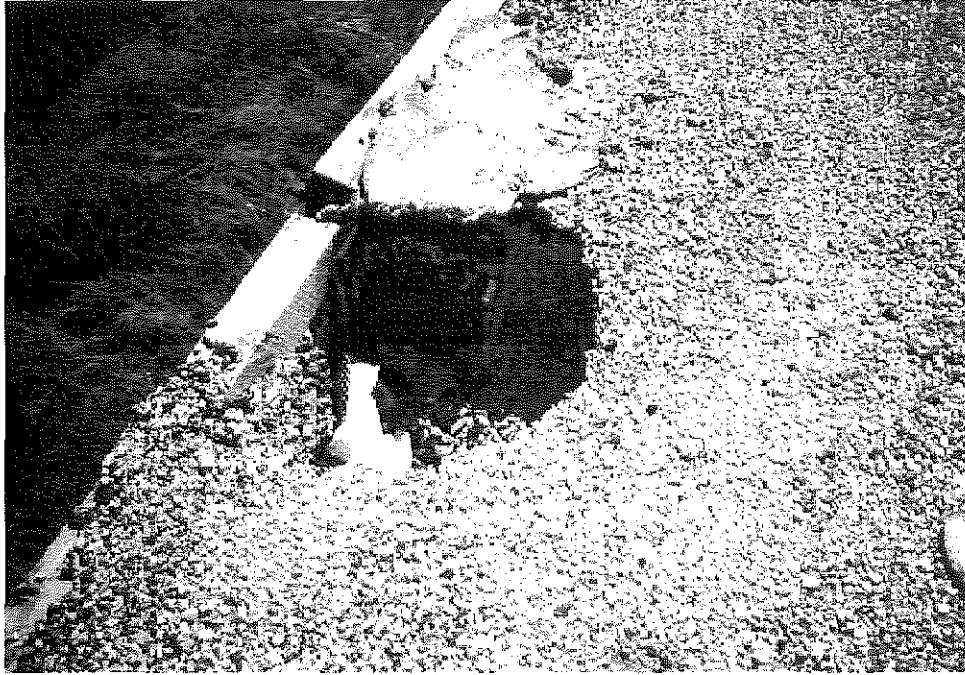

Figure 73: Erosion of Backfill (Campbell County, US 27)

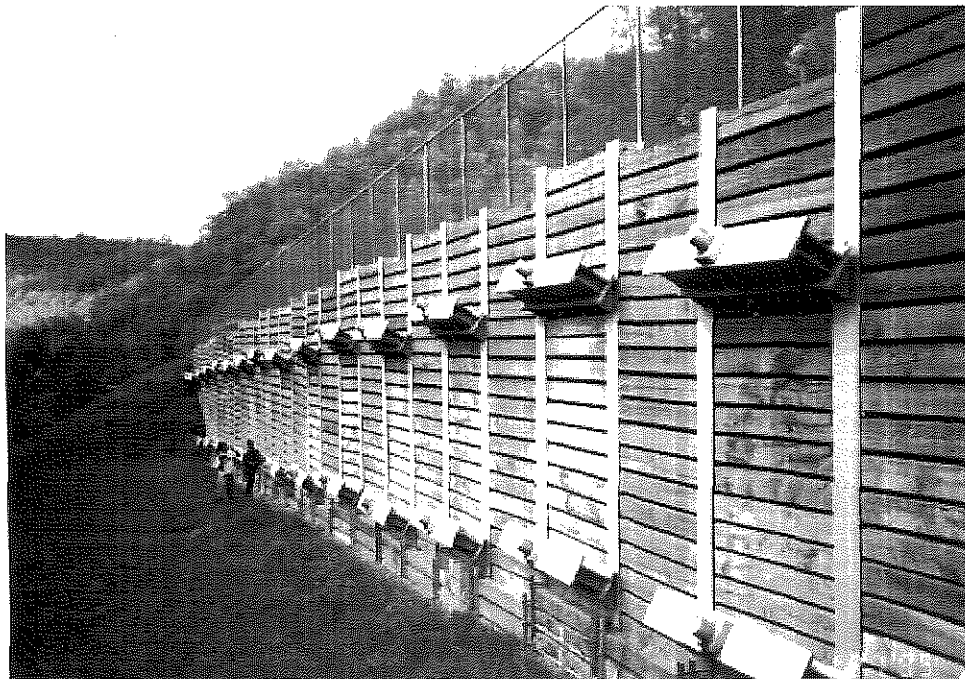

Figure 74: Single Tieback per Whaler (Leslie County, KY 118)



Figure 75: Tieback Attached to H-Pile (Greenup County, US 23)

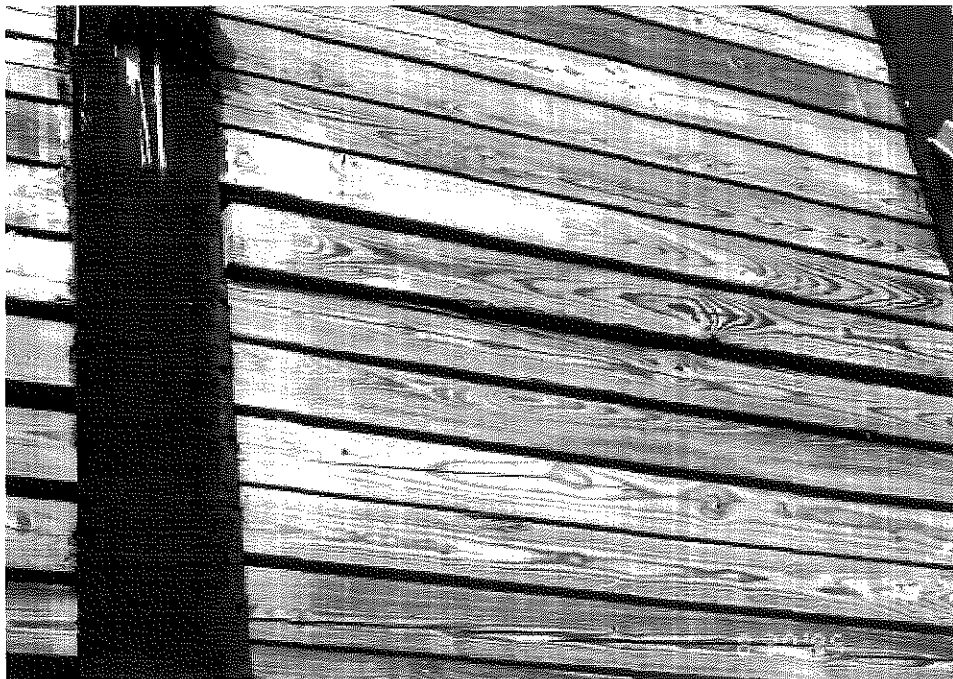

Figure 76: Slight Displacement of Timber Lagging
(Greenup County, US 23)

Table 13. TIEDBACK WALL (WOOD LAGGING HELD UP WITH TIES)

LOCATION				SECTION								
				OBSERVED DISTRESS								
COUNTY	RT	MP	DIR	1	2	3	4	5	6	7	8	9
CARROLL fig. 68,69,70	US 227	1	SB	5c,6c,7c	6c	6c	6c	6c	6c	5c,6c,7c	6c	6c
CAMPBELL fig. 67,71,72,73	US 27		NB	6c,9b	3b,6c,9b	5c,6c,7c	6c,9b	3b,6c	6c	6c,9b	3b,6c	6c
				DISTRESS OBSERVED AVG. (%)								
				5c=50%	3b=50%	5c=50%	6c=100%	3b=50%	6c=100%	5c=50%	3b=50%	6c=100%
				6c=100%	6c=100%	6c=100%	9b=50%	6c=100%		6c=100%	6c=100%	
				7c=50%	9b=50%	7c=50%				7c=50%		
				9b=50%						9b=50%		

67

Table 14. TIEDBACK WALL (WOOD LAGGING PLACED BETWEEN SOLDIER BEAMS)

LOCATION				SECTION								
				OBSERVED DISTRESS								
COUNTY	RT	MP	DIR	1	2	3	4	5	6	7	8	9
LESLIE fig. 74	KY 118	3	EB					4a,9a				
GREENUP fig. 75,76	US 23	12.3	NB	9a			9a	9a	5c,9a		4a,9a	
				DISTRESS OBSERVED AVG. (%)								
				9a=50%			9a=50%	4a=50%	5c=50%		4a=50%	
								9a=100%	9a=50%		9a=50%	

DISTRESS

- | | | | |
|------------------|--------------------------|-------------------------------|--------------|
| 1. VERT. DISP. | 4. MIGRATION OF BACKFILL | 7. BROKEN TIMBER LAGGING TIES | 10. STAINING |
| 2. HORIZ. DISP. | 5. LOOSE TIMBER LAGGING | 8. BULGING | 11. CRACKING |
| 3. FORWARD DISP. | 6. RUSTING | 9. DISP. OF TIMBER LAGGING | |

SIGNIFICANCE OF DISTRESS

- A = SLIGHT
B = MODERATE
C = SEVERE

Table 15. TIEDBACK WALL (CONCRETE FACING)

LOCATION				SECTION								
				OBSERVED DISTRESS								
COUNTY	RT	MP	DIR	1	2	3	4	5	6	7	8	9
CAMPBELL	471 on ramp from Ky. 8	.998	SB/WS	10a,11a	10a,11a	10a,11a	10a,11a	10a,11a	10a,11a	10a,11a	10a,11a	10a,11a
			SB/ES	10a,11a	10a,11a	10a,11a	10a,11a	10a,11a	10a,11a	10a,11a	10a,11a	10a,11a
KENTON	12 St. onto I-75 NB	190.67	NB/ES									
			NB/WS									
FAYETTE	S. BRD.	6.021	NB/WS	11a	11a	11a	11a	11a	11a	11a	11a	11a
			NB/ES	11a	11a	11a	11a	11a	11a	11a	11a	11a
KENTON L.S. # 1	KY 8		WEST	10a	10a	10a	10a	10a	10a	10a	10a	10a
L.S. # 2				10a	10a	10a	10a	10a	10a	10a	10a	10a
				DISTRESS OBSERVED AVG. (%)								
				10a=66%	10a=66%	10a=66%	10a=66%	10a=66%	10a=66%	10a=66%	10a=66%	10a=66%
				11a=66%	11a=66%	11a=66%	11a=66%	11a=66%	11a=66%	11a=66%	11a=66%	11a=66%

DISTRESS

- | | | | |
|------------------|--------------------------|-------------------------------|--------------|
| 1. VERT. DISP. | 4. MIGRATION OF BACKFILL | 7. BROKEN TIMBER LAGGING TIES | 10. STAINING |
| 2. HORIZ. DISP. | 5. LOOSE TIMBER LAGGING | 8. BULGING | 11. CRACKING |
| 3. FORWARD DISP. | 6. RUSTING | 9. DISP. OF TIMBER LAGGING | |

SIGNIFICANCE OF DISTRESS

- A = SLIGHT
 B = MODERATE
 C = SEVERE

2.8 MECHANICALLY STABILIZED EARTH RETAINING WALLS (M.S.E.)

Seventy-seven M.S.E. retaining walls were inspected. Seventy-five walls were manufactured by the Reinforced Earth Company. The other two walls were manufactured by the VSL Retained Earth Corporation. For the purpose of this evaluation, the M.S.E. walls were classified into five categories: open bridge abutments, closed bridge abutments, wing walls, return walls, and soil-retention walls. Schematics of the five categories are shown in Figures 77 through 79. As shown in the schematics, the individual walls were divided into nine sections to help quantify repeated distress patterns.

2.8.1 M.S.E. Open bridge Abutment Retaining Walls

The M.S.E. open bridge abutment retaining walls appear to have performed well. All nine of the inspected walls in this category were manufactured by the Reinforced Earth Company. A statistical analysis shows that only one wall had forward and backward displacement at the time of evaluation (Figure 80). However, the forward and backward displacement observed in this wall along I-65 in Bullitt County did not exceed the vertical tolerance outlined in Special Provision No. 66L (94)(plumbness from top to bottom shall not exceed 4 mm in one meter (1/2 inch per 10 feet) of wall height) (Appendix D). Distress information from the inspection of the M.S.E. open bridge abutment retaining walls is contained in Table 16.

2.8.2 M.S.E. Wing Walls

Twenty-seven M.S.E. wing walls were inspected under this study. Eighteen of the wing walls were adjoined to M.S.E. open bridge abutment walls, while the other nine wing walls were adjoined to cast-in-place abutment walls. All twenty-seven M.S.E. wing walls were manufactured by the Reinforced Earth Company. A statistical analysis shows that, on average, the majority of the wing walls have performed well with the exception of four walls (Figure 81). In 1995, significant cracking was observed in the MSE wall on Mall Road and I-75 Southbound in Boone County (Figure 82). It is apparent that a cast-in-place block placed between the bridge deck and the edge of the wing wall is transferring loads from the bridge deck onto a portion of the M.S.E. wing wall and the abutment wall. During the inspection of the wall in 1995, it was apparent the base of the cast-in-place block was cracked and a portion had broken away. The wall was inspected again in 1997, and the remainder of the cracked block had broken away (Figure 83). On the opposite side of this same bridge, one of the panels has started to move forward approximately 38 mm or 1 ½ inches (Figure 84). This exceeds the maximum allowable offset in any panel joint that is outlined in Special Provision No. 66L (94)(the maximum allowable offset in any panel joint shall be 19 mm (3/4 inch)) (Appendix D).

Significant distress also was observed in the M.S.E wing walls for a bridge on KY 225 in Knox County (Figures 85 and 86). Figure 85 shows where the M.S.E. wall has started to settle in sections four and seven and has consequently, left a 76.2 mm (3 inch) vertical gap between the top two precast panels. It appears the precast cap block is keeping the top row of blocks from settling. Figure 86 shows where the M.S.E. wing wall has started to rotate clockwise from the middle of the wall due to settlement in the toe of the M.S.E. wall. Distress information from the inspection of the M.S.E. wing walls is included in Table 17.

2.8.3 M.S.E. Closed Bridge Abutment Retaining Walls

Thirteen closed bridge abutment M.S.E. retaining walls were inspected under this study. All thirteen closed abutment walls were manufactured by the Reinforced Earth Company. A statistical analysis shows that most of the walls in this category have performed well with the exception of three walls (Figure 87). In two of the M.S.E walls, a cast-in-place block has been cast between the bridge deck and the top of the M.S.E. wall. The block is apparently transferring a portion of load from the bridges to the top of the M.S.E. walls. This was observed in the wall located on Jefferson Street in Lexington (Figures 88 and 89), and again, on the M.S.E wall discussed earlier on Mall Road (Figure 90).

The third distressed closed abutment wall was located in Jefferson County on I-264. Fines have migrated between the precast panels in sections seven, eight, and nine (Figure 91). Distress information from the inspection of the M.S.E. closed bridge abutment retaining walls is contained in Table 18. It has also been mentioned by state transportation officials that the use of M.S.E. walls passing through notches are undiserable.

2.8.4 M.S.E. Return Walls

Twenty-three M.S.E. return walls were inspected. The walls were all manufactured by the Reinforced Earth Company. Several recurring distress patterns were observed in the return walls. These included horizontal, vertical, and forward displacement; cracking; spalling; and staining. A statistical analysis shows the majority of the distress was located in sections one, four, and seven (Figure 92). One overpass in Kenton County on the I-275 ramp from I-75 had four distressed M.S.E. return walls. Figures 93a thru 95b show the actual vertical, horizontal, and forward displacements of the precast panels measured in millimeters. The majority of the measurements recorded exceeded the allowable tolerance for panel joint offsets as stated in Special Provision No. 66L (94) (Appendix D). In addition to measuring the offsets of the panel joints, a ruler was placed through one of the offset joints noted in Figure 95b. At the time of the inspection, the ruler penetrated 559 mm (22 inches) (Figure 96).

Other problems with the M.S.E. return walls were observed in Lexington on Jefferson Street. These problems consisted of spalling of the precast panels (Figure 97), and staining/vegetation growing through panel joints (Figure 98). Vegetation was also observed growing through the panel joints on a M.S.E wall located on I-264, in Jefferson County (Figure 99). Distress information from the inspection of the M.S.E. return walls is contained in Table 19.

2.8.5 M.S.E. Soil-Retention Walls

There were five M.S.E. soil-retention walls evaluated. Three of the five M.S.E. soil-retention walls were manufactured by the Reinforced Earth Company and two were manufactured by the VSL Corporation. The walls in this category have performed well with the exception of one VSL wall in Kenton County. The wall is approximately 30 meters (100 ft.) long and adjoins a tiedback wall. It is apparent the top row of blocks is experiencing slight-to- moderate forward displacement and cracking. It is believed the forward displacement may be attributed to water discharging from headwalls located directly behind the VSL wall (figure 100). Distress information

from the inspection of the M.S.E. soil-retention walls is included in Table 20.

2.8.6 Discussion

In most cases, the M.S.E. wing walls and soil-retention walls have performed well. It is apparent that some of the walls have settled since construction. Settlement has caused some shifting and cracking in isolated areas (Figure 85 and 86).

Poured concrete panels placed between the bridge deck and the top of the M.S.E walls on several structures appear to be transferring vertical loads to the M.S.E. walls. Consequently, the M.S.E. wall panels have started to crack (Figures 83, 89, and 90). Conversations with state personnel indicated that expansion joint material should have been placed on top of the poured panels.

The most significant and recurring distress observed in the M.S.E systems have been observed in the M.S.E return walls. Wall distresses such as forward, horizontal, and vertical displacement; cracked precast panels; and staining were observed in the M.S.E. return walls. It appears some of the distress may be caused by water in the approach fill embankments and lateral earth pressure from bridge approach settlement. Information contained in the Reinforced Earth Manual for Bridge Abutments indicates that water must be prevented from seeping under the beam seat, where it could cause settlement or subsidence after saturation, or leech and wash away fines (Appendix E). An indication that water has been leeching and washing away fines in some of the M.S.E. walls is shown in Figures 94b and 95b. It is believed that once the fines are allowed to wash away and settlement is initiated that the precast panels have the opportunity to displace. It is possible that the distresses noted in Figures 93a thru 95b are consequences of settlement and erosion of fines.

Migration of the granular backfill through joints in the precast M.S.E panels was observed at the base of some closed-abutment walls (Figure 91) and in some of the wing walls in which the panels had settled and separated.

It appears that on several of the walls that geotextile may not have been used at the joint interface of the precast panels. According to Special Provision No. 66L (94), panel joints shall have geotextile fabric placed on the backside of the panels with a minimum width and lap of all fabric sheets to be as follows: vertical joints - 457 mm (18 inches); horizontal joints - 305 mm (12 inches); and all laps in fabric to be 102 mm (4 inches) (Appendix D). A foam-like material was noted between the panel joints on I-75 to I-275 ramp in Kenton County. During the inspection of this particular wall, a piece of this foam material was observed hanging out of the panel joint exposing the backfill.

Other problems associated with M.S.E walls was spalling of the precast panels (Figure 97), and vegetation growing through the panel joints (Figures 98 & 99). The vegetation growing between the panel joints is an indication that the joint of the panel could be partially separated.

2.8.7 Recommendations

Level pads for wing walls should be placed on suitably compacted earth. The precast panels

or cast-in-place blocks placed between the bridge deck and M.S.E. wall should not be permitted to link the two structures. The use of M.S.E. walls in notches should be avoided. All approach fills should be properly drained. When bridge-end drainage is installed, a miniature pipeline camera should be used to inspect the integrity of the drainage system during construction. When constructing a M.S.E. wall, geotextile fabrics should be used as outlined in Special Provision No. 66L (94) (Appendix D). Water should not be discharged from headwalls directly behind M.S.E. structures. Damaged precast panels and wall components should be rejected at the job site during construction.

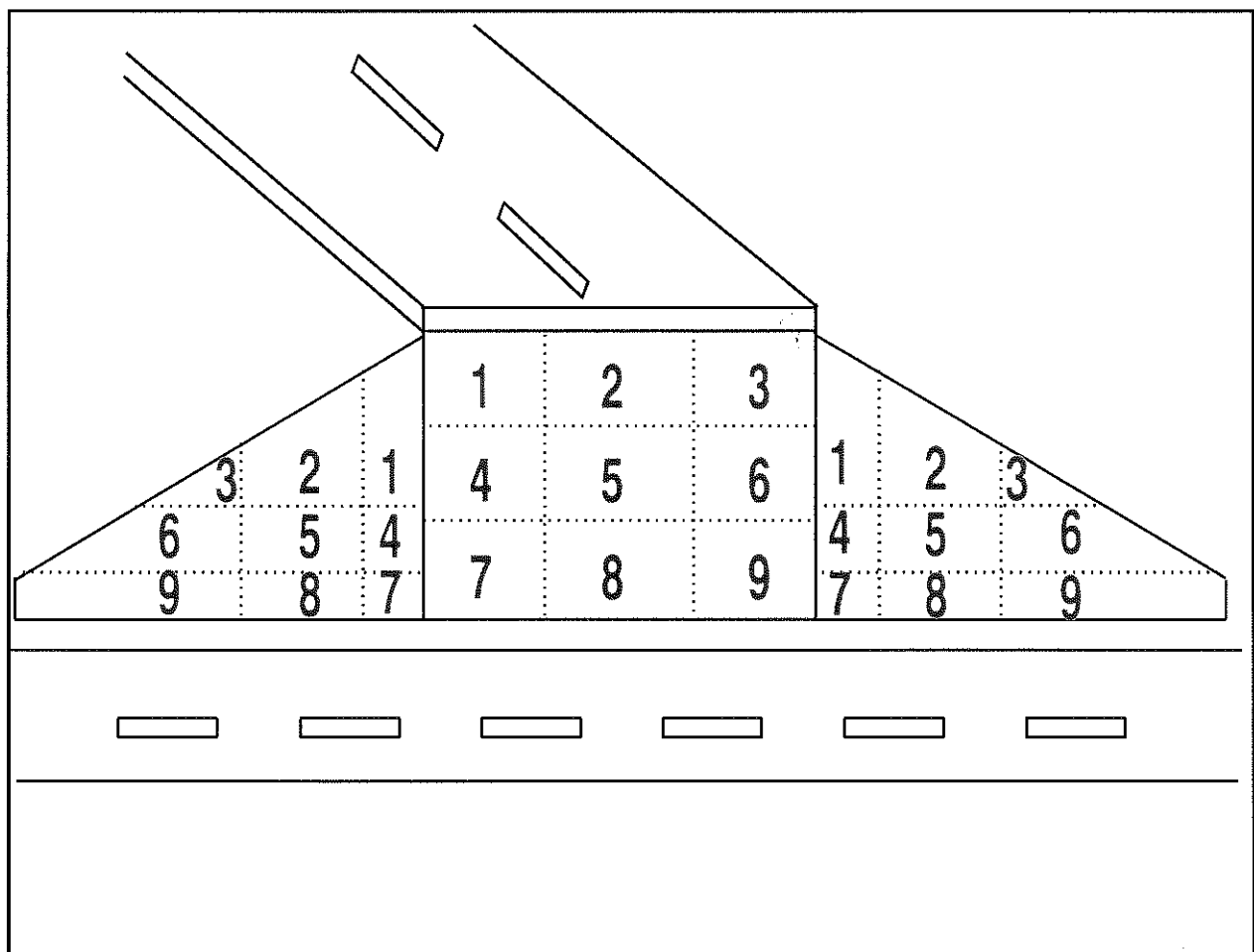

Figure 77: M.S.E. Open Bridge Abutment with Wing Walls

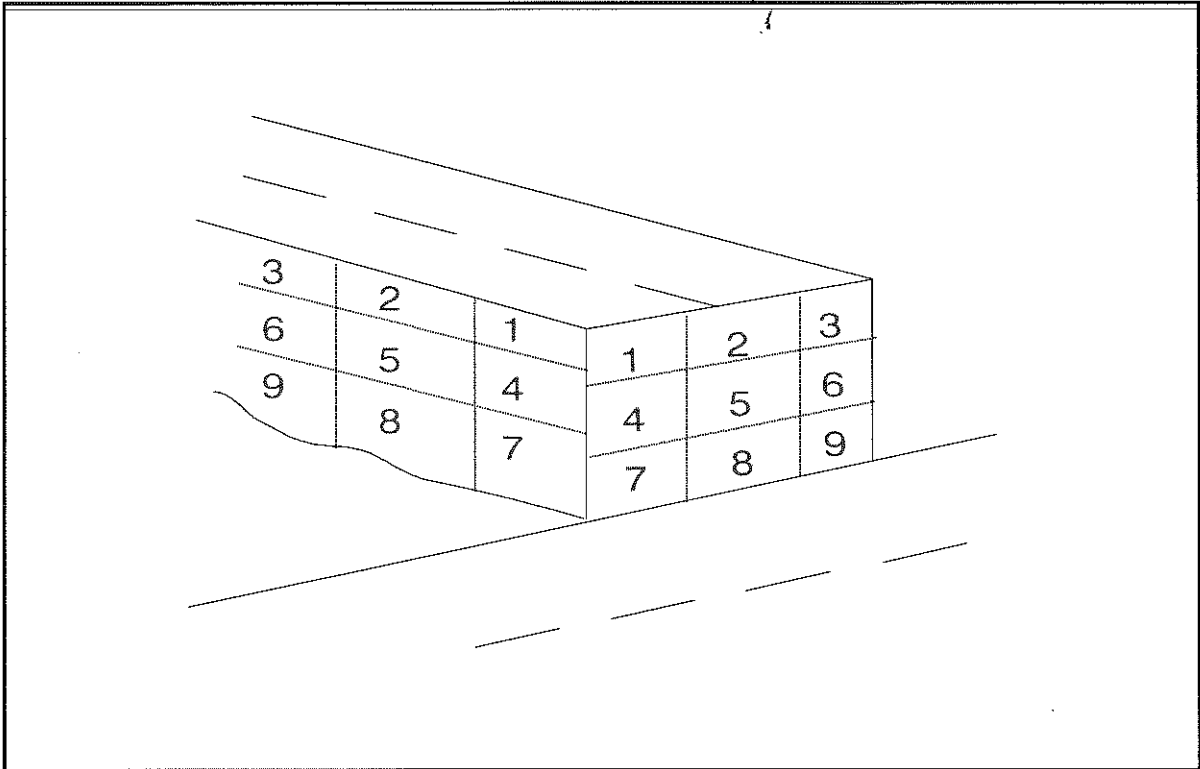

Figure 78: M.S.E. Closed Bridge Abutment with Return Walls (Approach Fill)

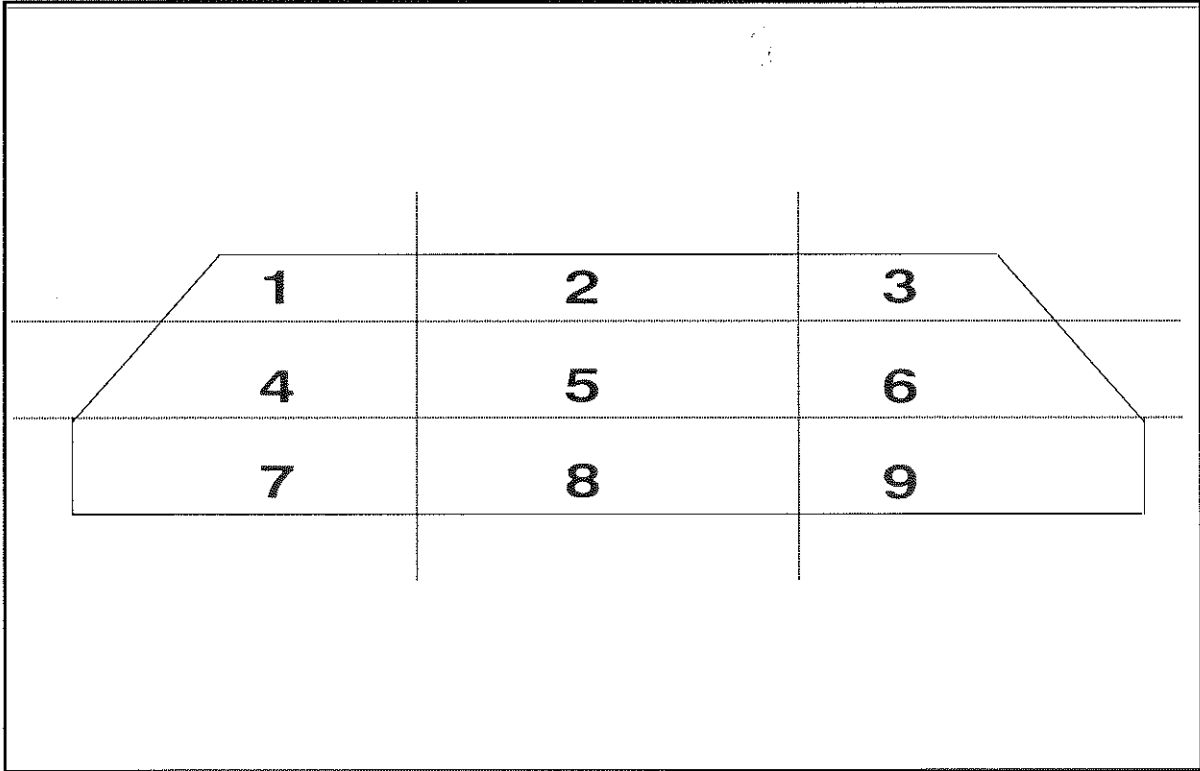

Figure 79: M.S.E. Soil Retention Wall

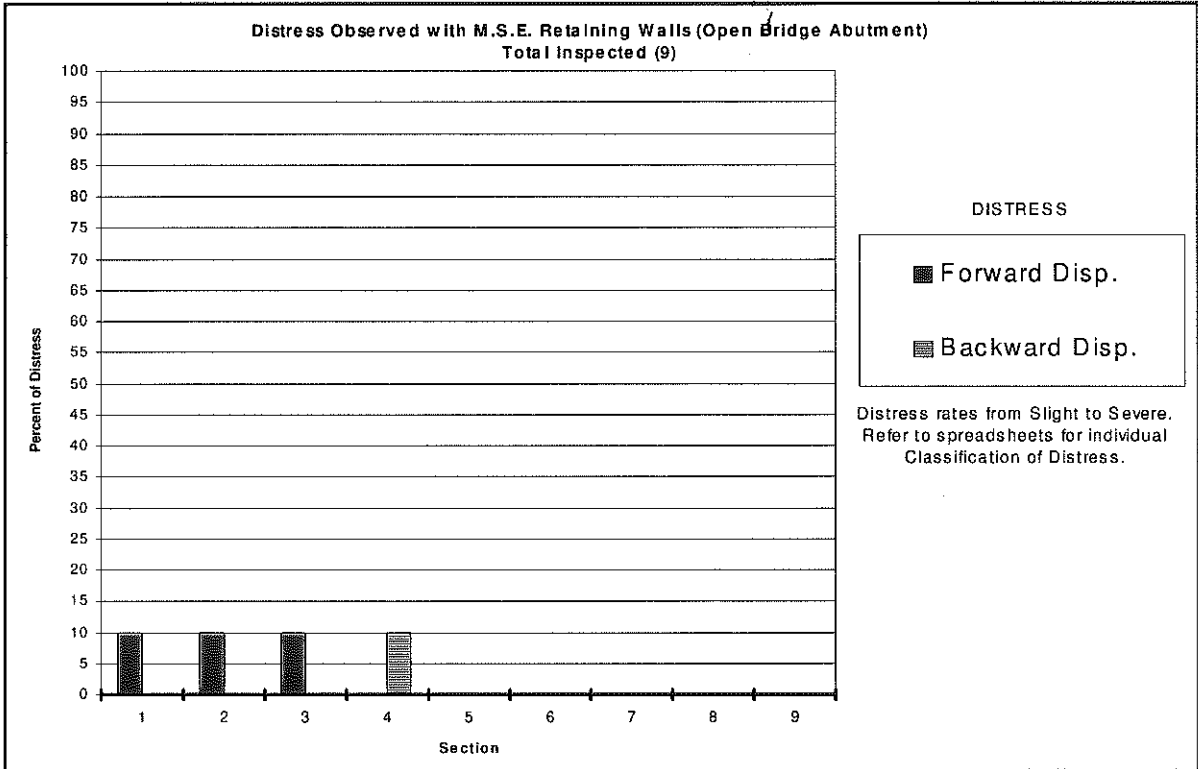

Figure 80: M.S.E. Open Bridge Abutment Distress Analysis

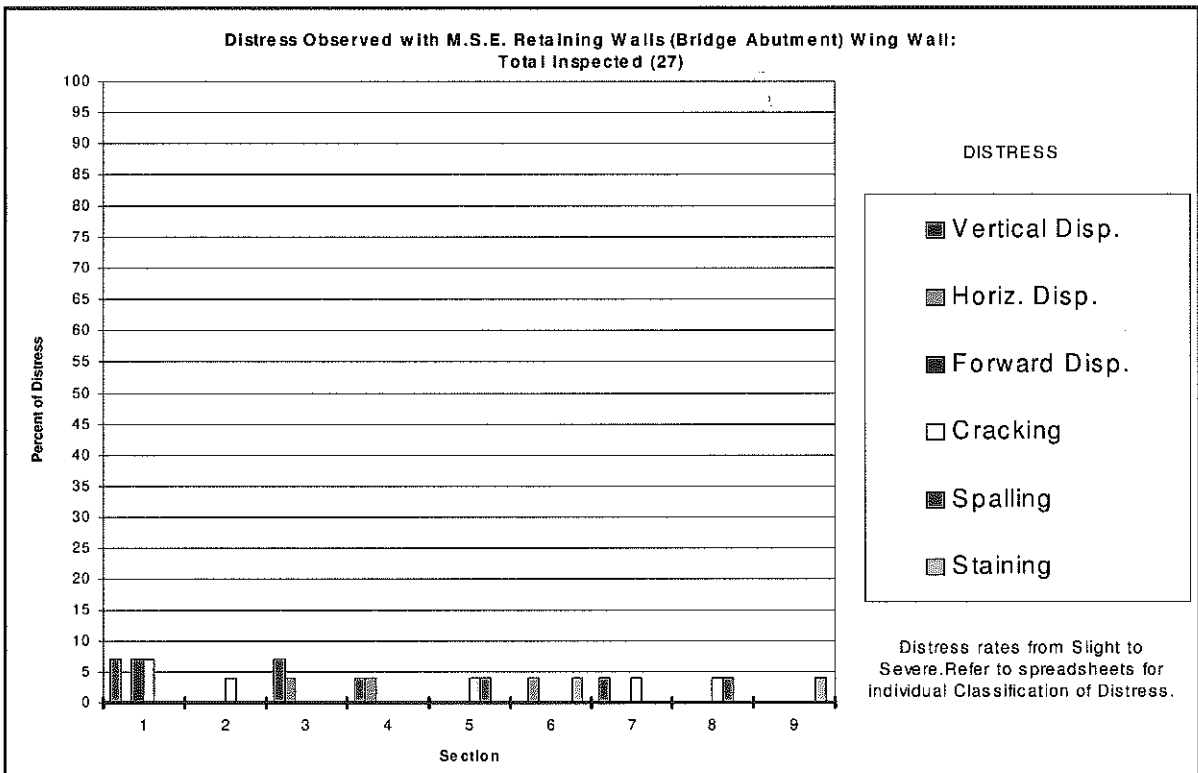

Figure 81: M.S.E. Wing Wall Distress Analysis

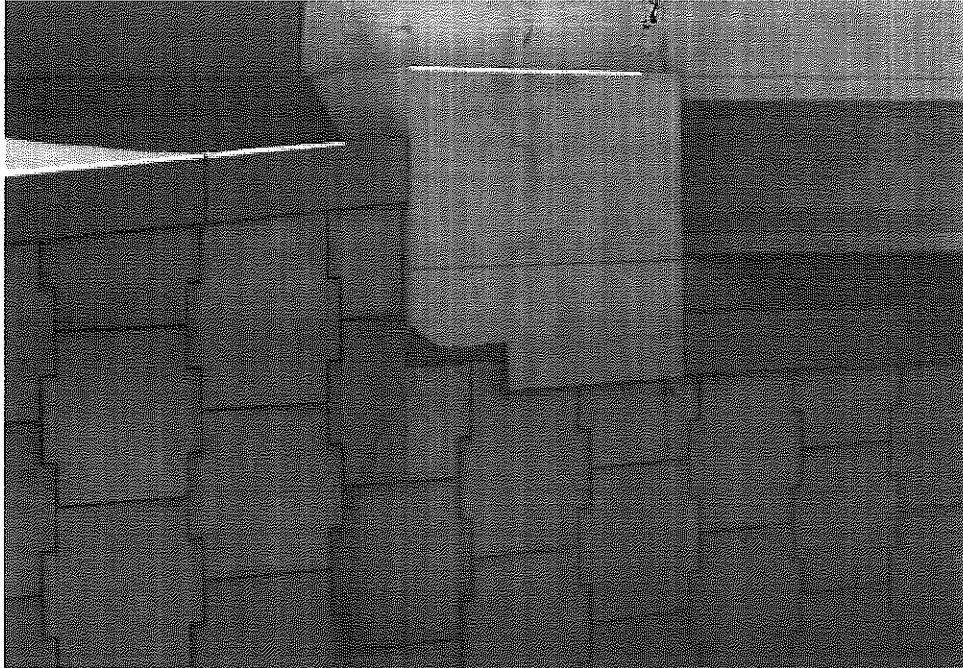

Figure 82: Cracked Precast Panel and Endbent (1995)
(Boone County, I-75 S.B. & Mall Rd.)

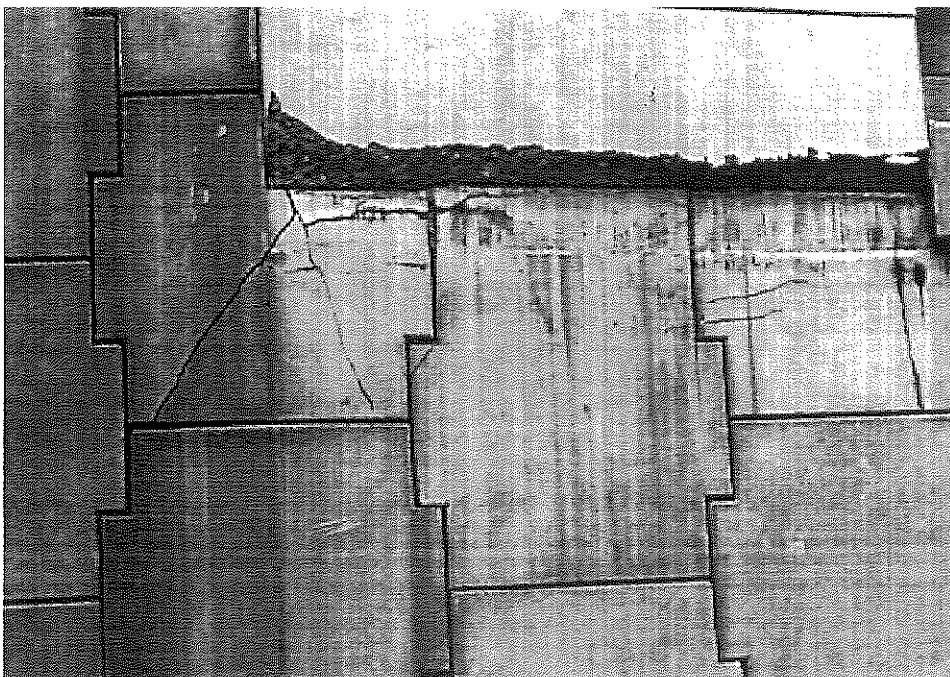

Figure 83: Cracked Precast Panel and Endbent (1997)
(Boone County, I-75 S.B. & Mall Rd.)



Figure 84: Forward Displacement of Precast Panel
(Boone County, I-75 S.B. & Mall Rd.)

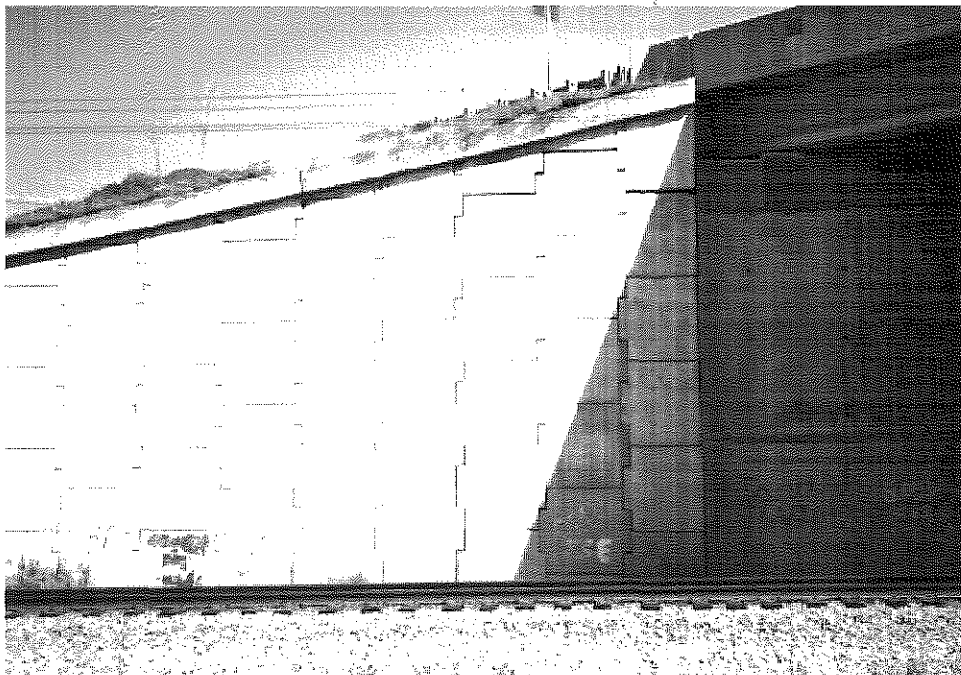

Figure 85: Settled M.S.E. Wall (Knox County, KY 225)

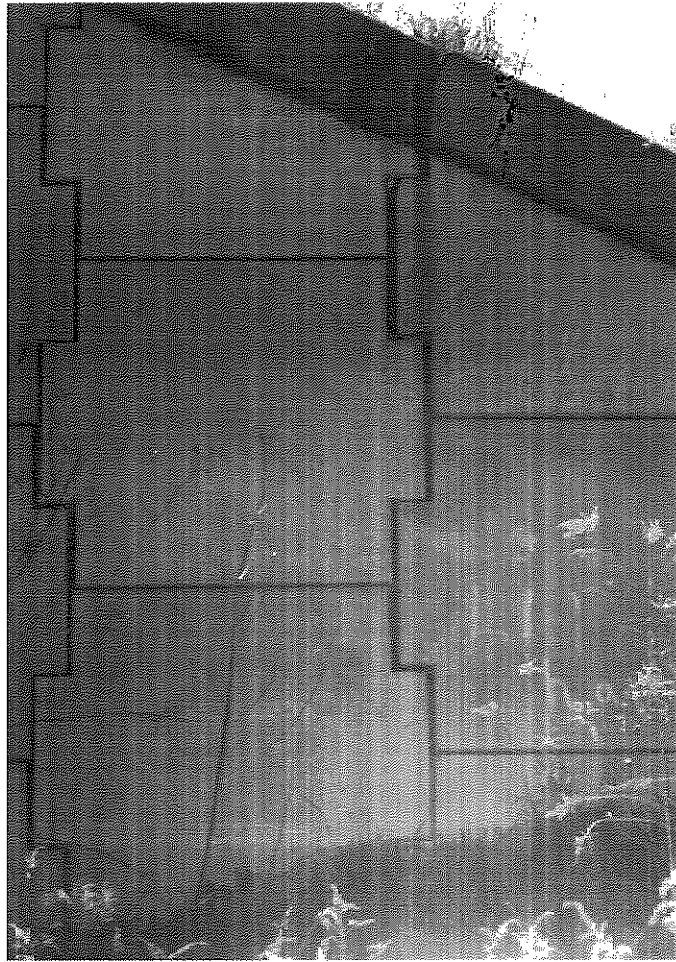

Figure 86: Settled M.S.E. Wing Wall
(Knox County, KY 225)

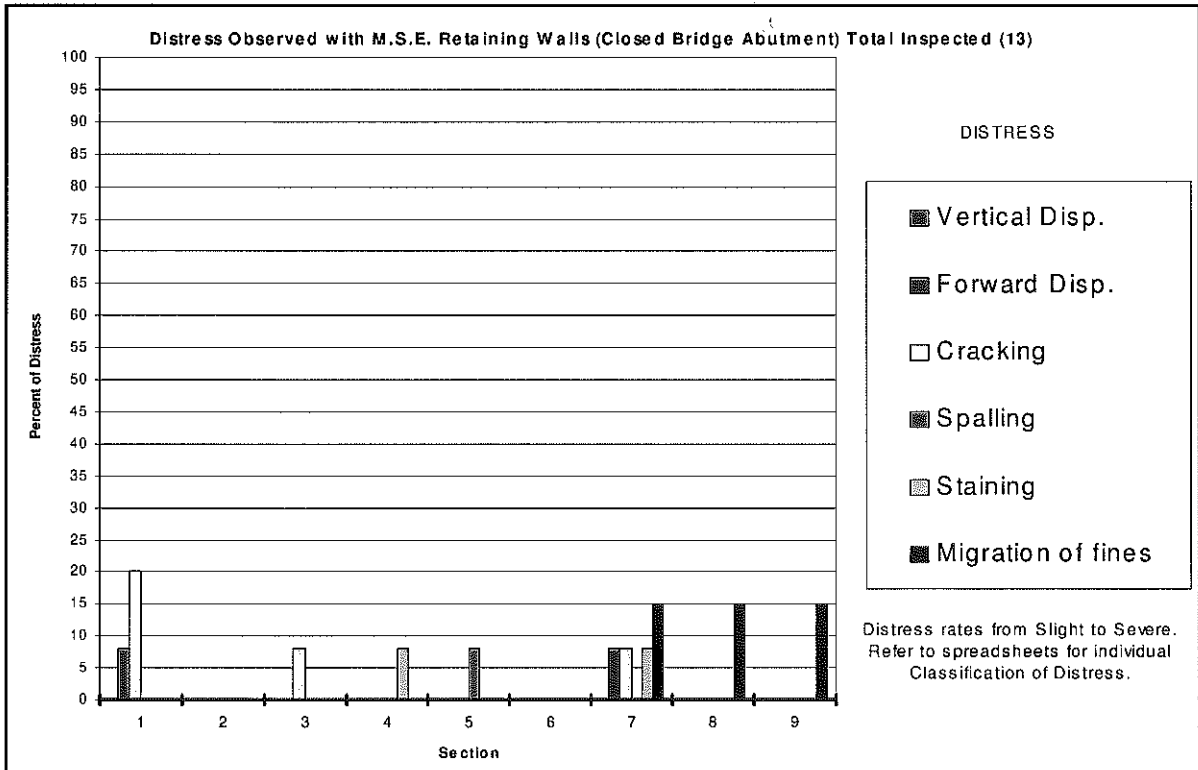

Figure 87: Closed Bridge Abutment Distress Analysis

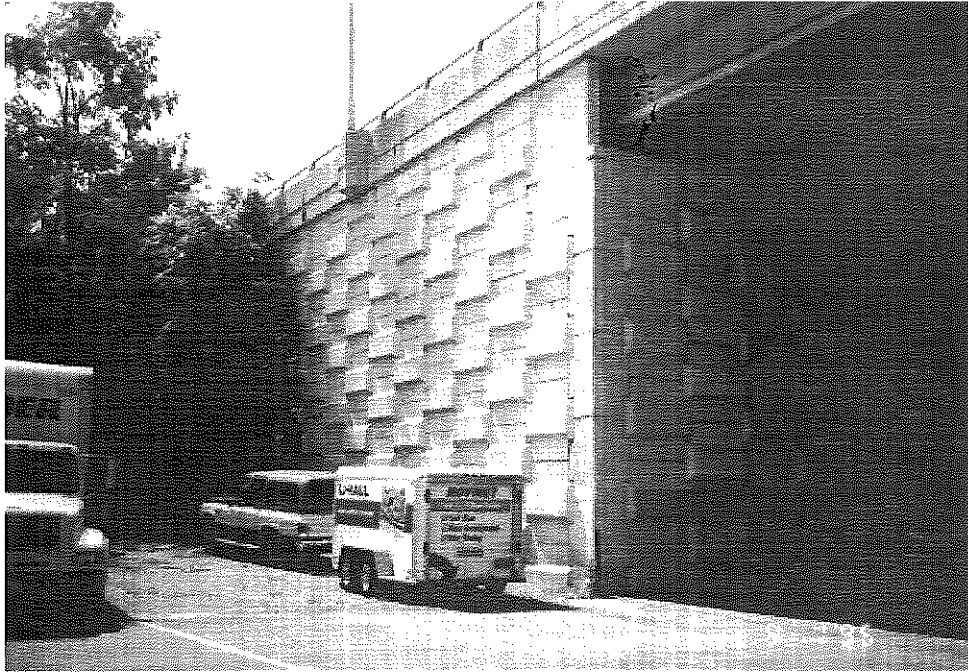

Figure 88: Extra Panel between Bridge Deck and M.S.E. Wall
(Fayette County, Jefferson Street)

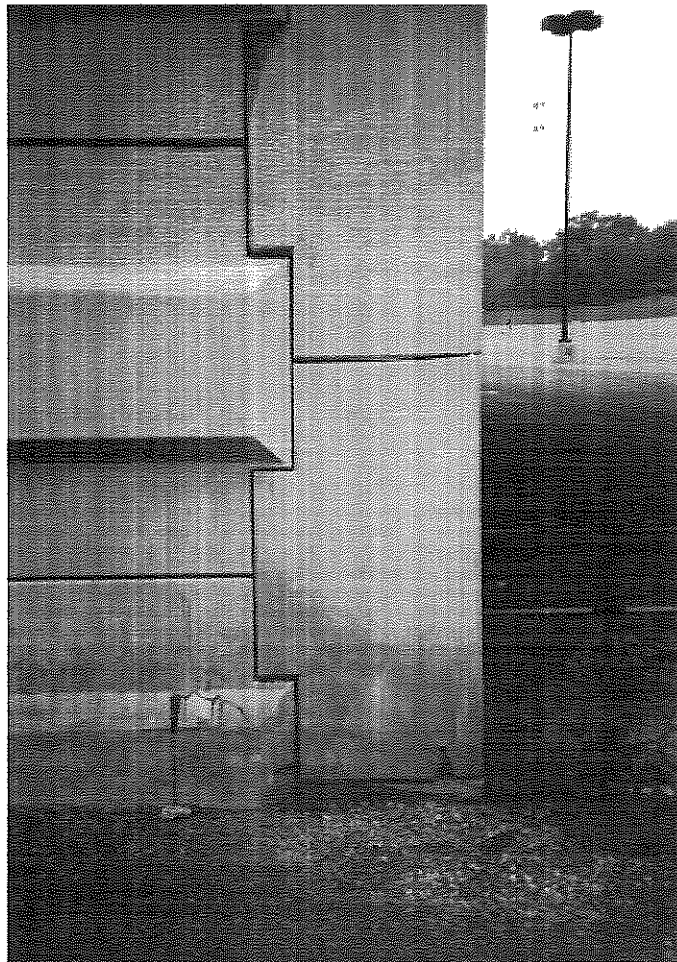

Figure 89: Cracking of Precast Panels
(Fayette County, Jefferson St.)

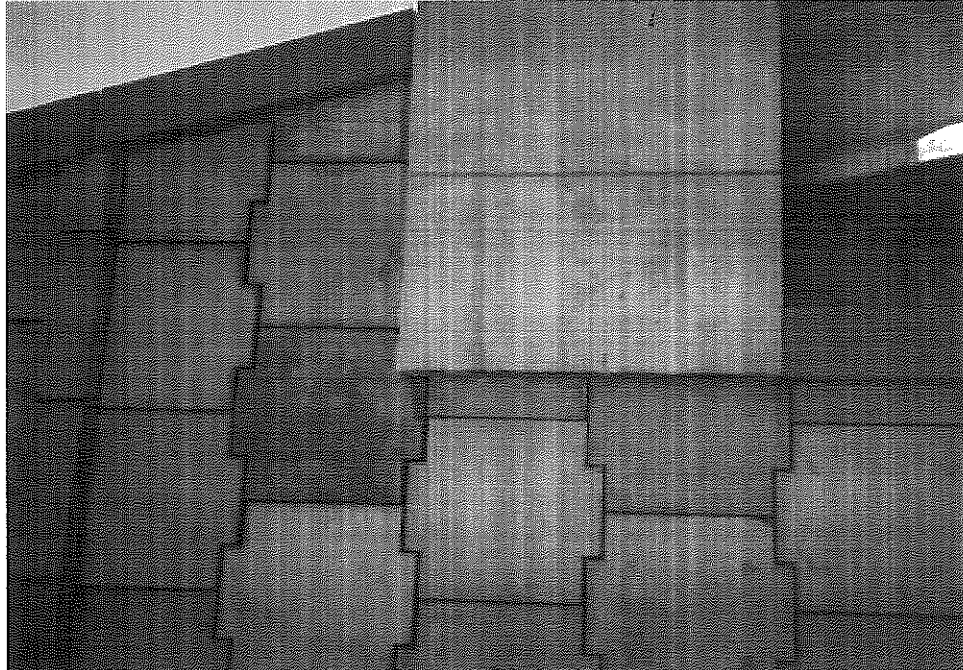

Figure 90: C.I.P. Block between Bridge Deck and M.S.E. Wall
(Boone County, I-75 S.B. & Mall Rd.)

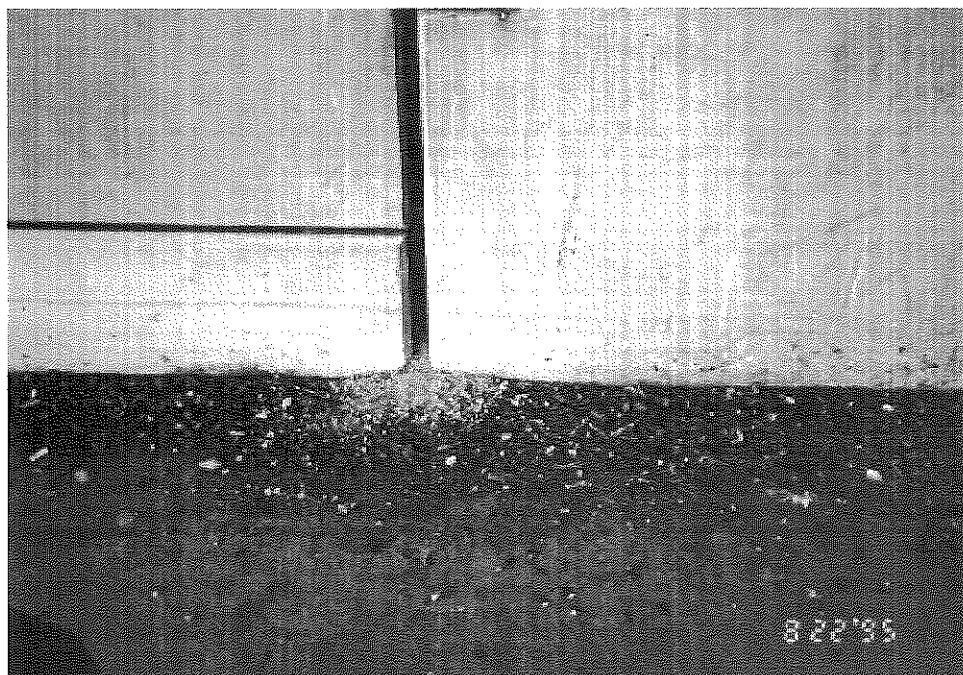

Figure 91: Migration of Fines (Jefferson County, I-264 & Taylorsville Rd.)

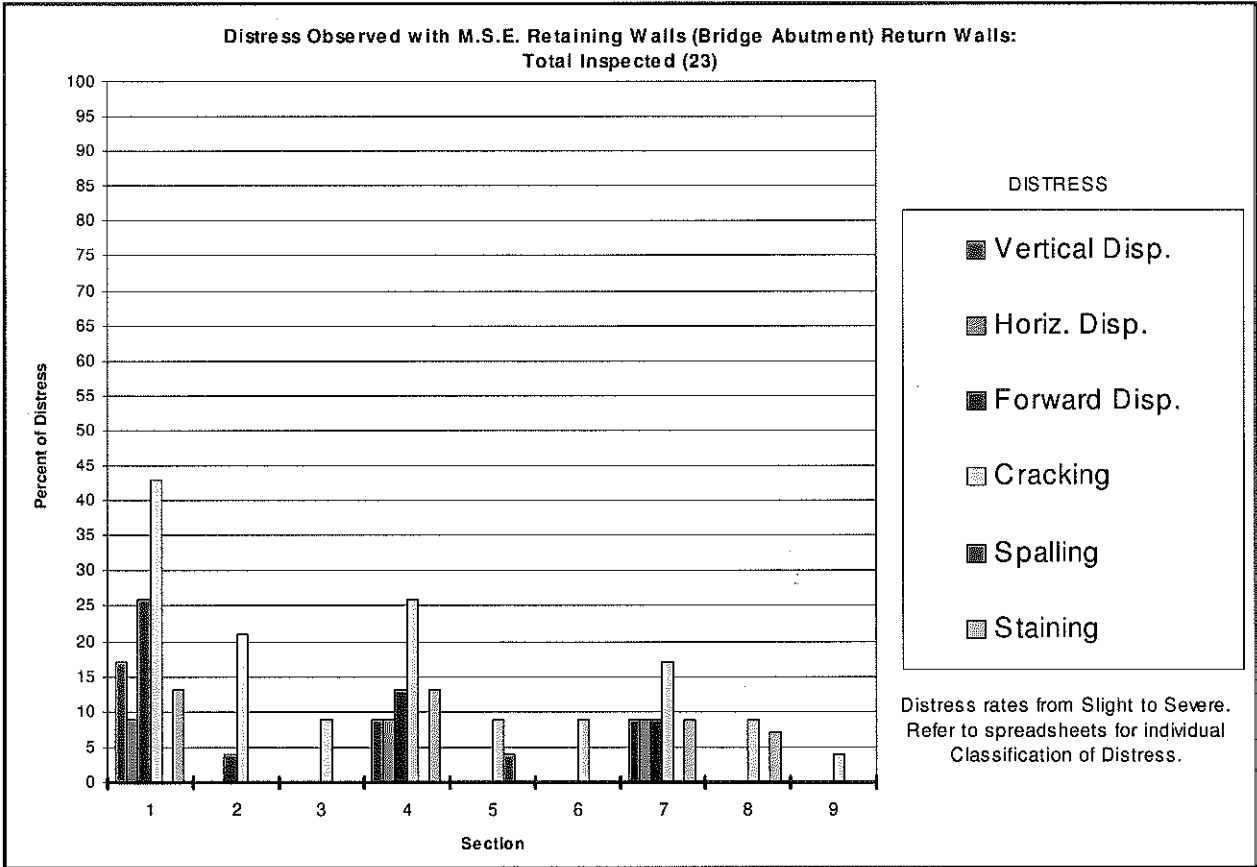

Figure 92: M.S.E. Return Walls Distress Analysis

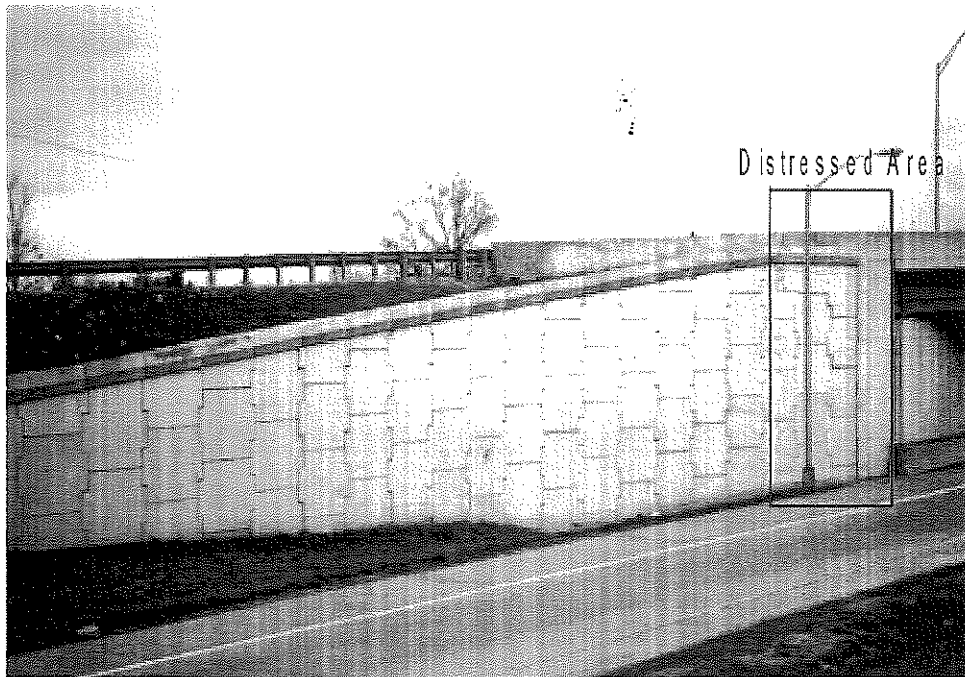

Figure 93a: Distressed Area on M.S.E. Wall (Kenton County, Wall # 1)

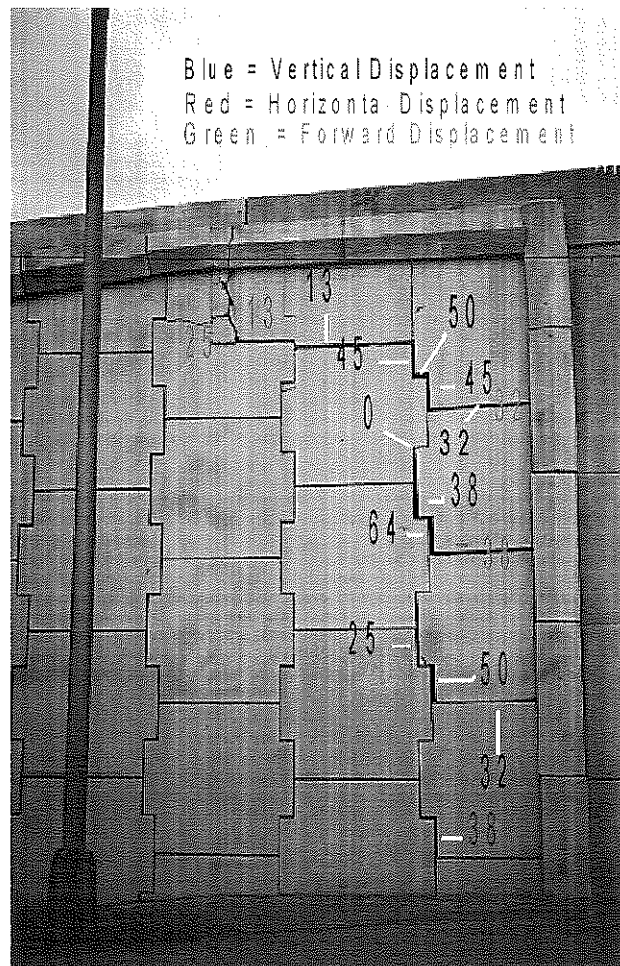

Figure 93b: Vertical, Horizontal, and Forward Displacement (Wall # 1)



Figure 94a: Distressed Area on M.S.E. Wall (Kenton County, Wall # 2)

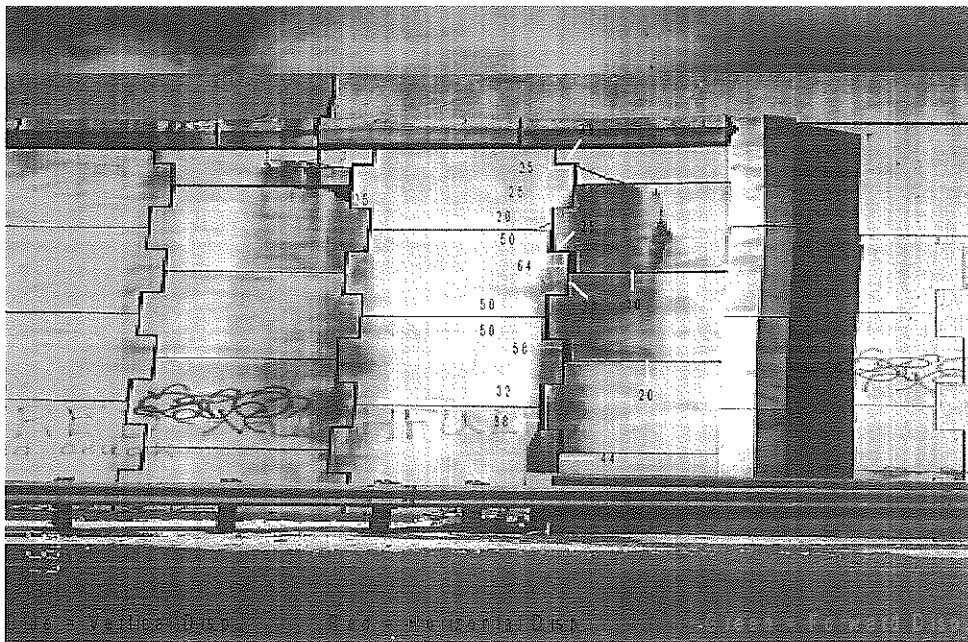

Figure 94b: Vertical, Horizontal, & Forward Displacement--Staining (Kenton County, Wall # 2)

Distressed Area



Figure 95a: Distressed Area on M.S.E. Wall (Kenton County, Wall # 3)

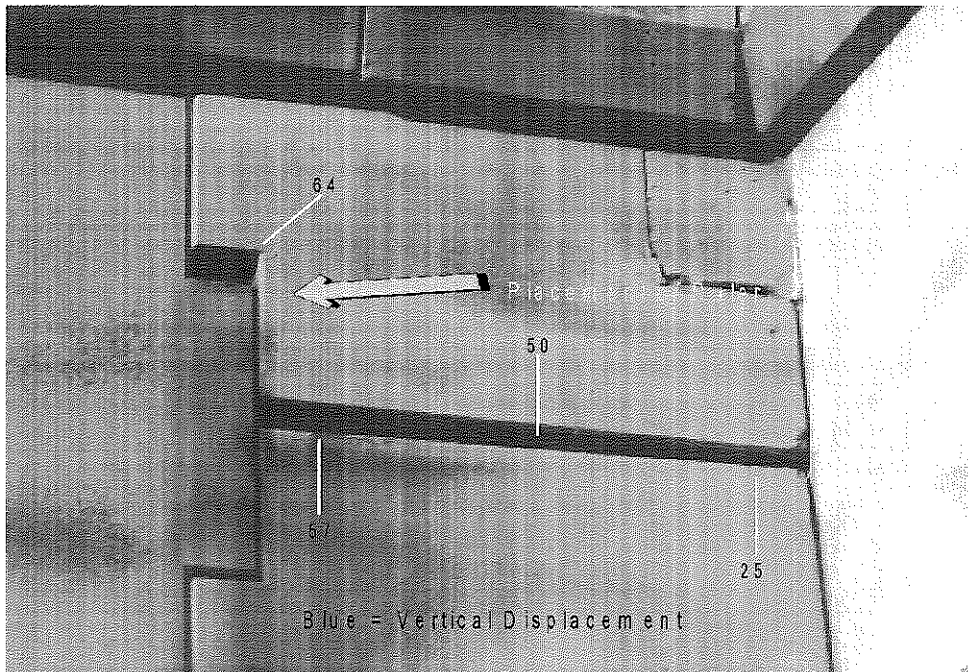

Figure 95b: Vertical and Horizontal Displacement (Wall # 3)

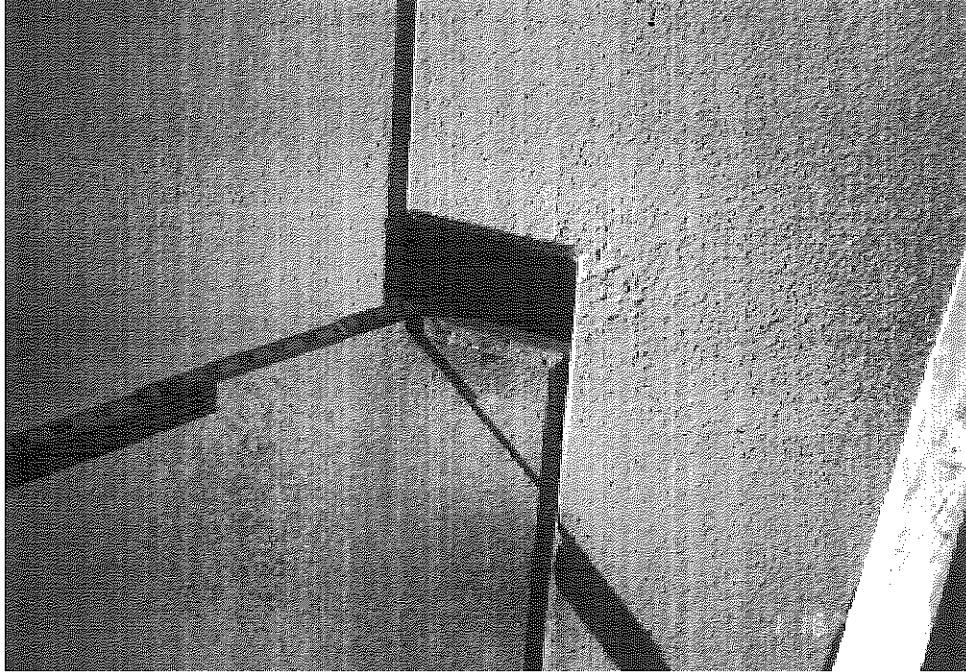

Figure 96: Ruler Placed 559 mm into Panel Joint
(Kenton County, I-75 & I-275 Wall # 3)

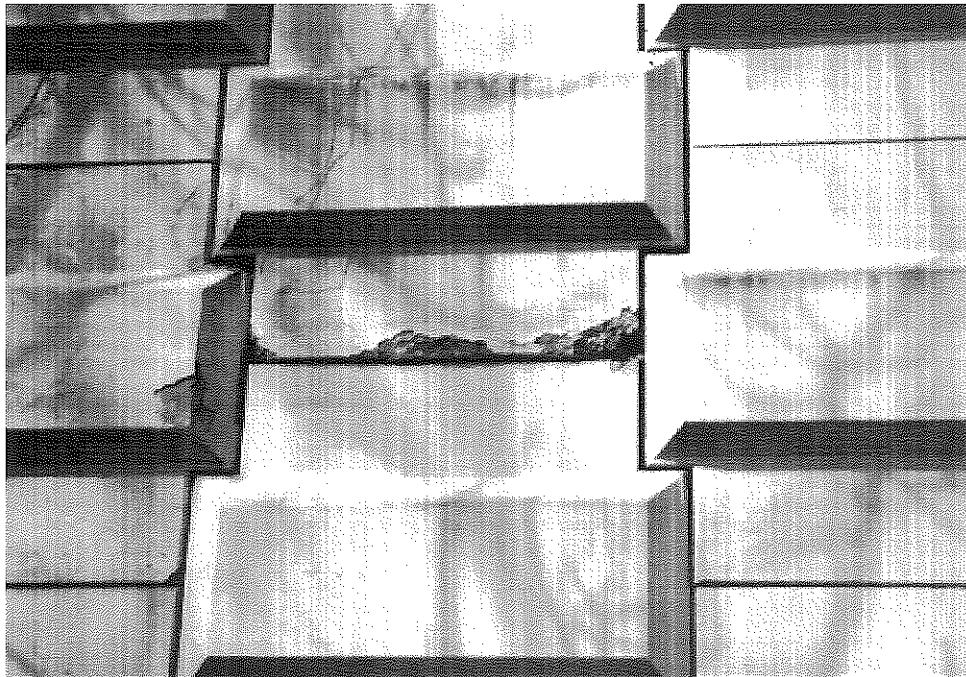

Figure 97: Spalling of Precast Panels (Fayette County, Jefferson St.)

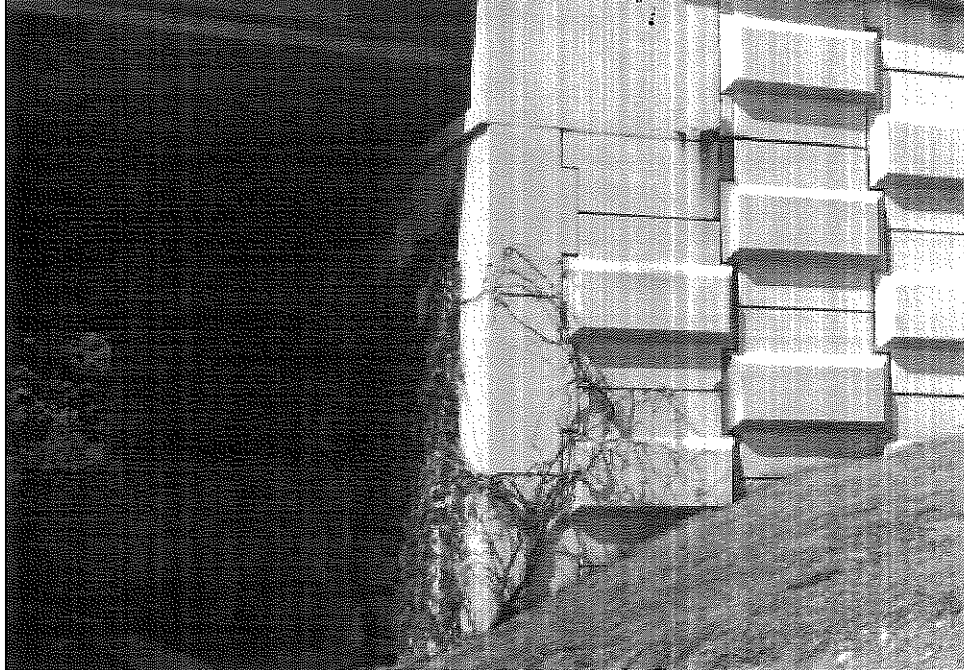

Figure 98: Staining & Vegetation Growing between Precast Panels
(Fayette County, Jefferson St.)

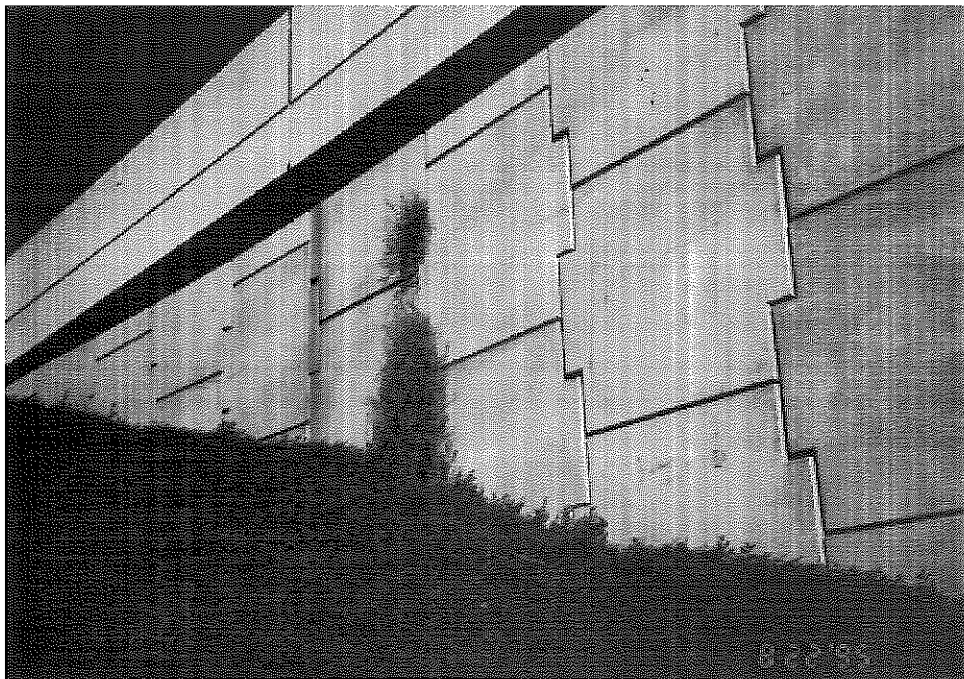

Figure 99: Vegetation Growing between Precast Panels
(Jefferson County, I-264 & Taylorsville Rd.)

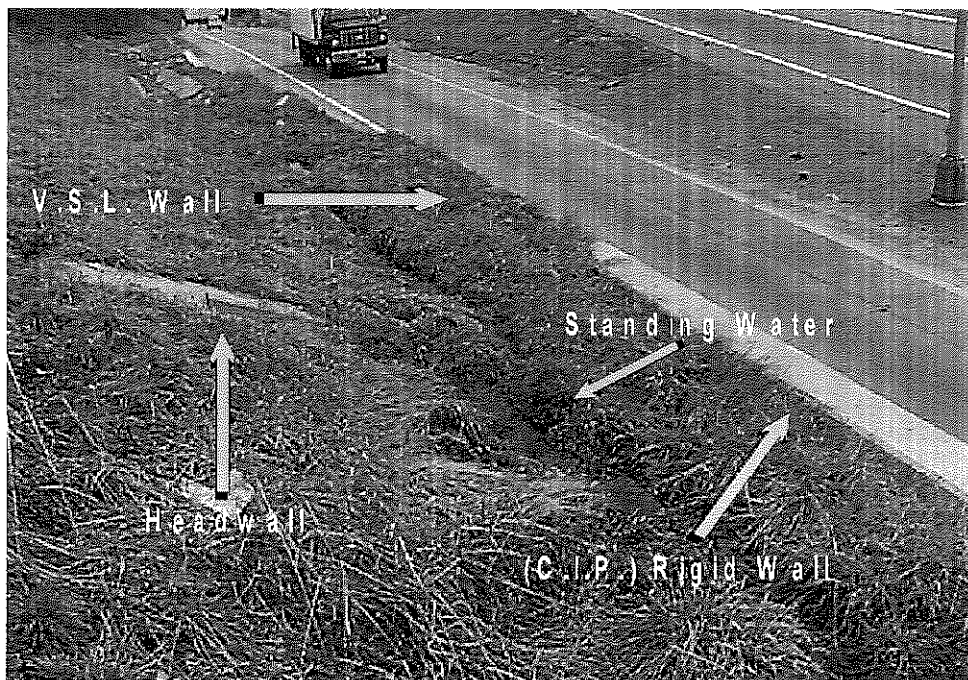

Figure 100: Water Standing Behind V.S.L. Wall
(Kenton County, I-75 S.B. from KY 8)

TABLE 16. M.S.E. RETAINING WALL (OPEN BRIDGE ABUTMENT)

LOCATION				SECTION								
				OBSERVED DISTRESS								
COUNTY	RT	MP	DIR	1	2	3	4	5	6	7	8	9
FLOYD	US23 & MT. PKY	15.609	SB									
fig. n/a			NB									
JEFFERSON	US 60 & 264	5.529	EB #1									
fig. n/a			EB #2									
			WB									
BULLITT	I-65 & R.R.	112	SB #1	3a	3a	3a	8a					
fig. n/a			SB #2									
			NB #1									
			NB #2									
				DISTRESS OBSERVED AVG. (%)								
				3a=11%	3a=11%	3a=11%	8a=11%					

DISTRESS

- 1. VERT. DISP.
- 2. HORIZ. DISP.
- 3. FORWARD DISP.

- 4. CRACKING
- 5. SPALLING
- 6. CORNER OF APRON BROKEN

- 7. STAINING
- 8. BACKWARD DISP.
- 9. MIGRATION OF FINES

SIGNIFICANCE OF DISTRESS

- A = SLIGHT
- B = MODERATE
- C = SEVERE

TABLE 17. M.S.E. RETAINING WALL (BRIDGE ABUTMENT WING WALL)

LOCATION				SECTION								
				OBSERVED DISTRESS								
COUNTY	RT	MP	DIR	1	2	3	4	5	6	7	8	9
JEFFERSON	264 & POP. LV	13.491	EB/WS									
fig. n/a			EB/ES									
			WB/ES					5a				
KNOX	KY 225	11	NB/ES	1a,3b,4b		1a	1a			1a		
fig. 85,86			SB/ES									
			NB/WS		4a	2a		4a	2a		4a	2a
			SB/WS			1a						
BOONE	I-75 & MALL	180.6	SB/ES #1	6a			6a					
fig. n/a			SB/ES #2									
JEFFERSON	US 60	5.529	E/NS									
fig. n/a			E/SS									

DISTRESS

- | | | |
|------------------|---------------------------|-----------------------|
| 1. VERT. DISP. | 4. CRACKING | 7. STAINING |
| 2. HORIZ. DISP. | 5. SPALLING | 8. BACKWARD DISP. |
| 3. FORWARD DISP. | 6. CORNER OF APRON BROKEN | 9. MIGRATION OF FINES |

SIGNIFICANCE OF DISTRESS

- A = SLIGHT
 B = MODERATE
 C = SEVERE

TABLE 17 CONTINUED. M.S.E. RETAINING WALL (BRIDGE ABUTMENT WING WALL)

LOCATION				SECTION								
				OBSERVED DISTRESS								
COUNTY	RT	MP	DIR	1	2	3	4	5	6	7	8	9
JEFFERSON	US 60	5.529	WS/WS									
fig. n/a			WS/SS									
BOONE	I-75 & MALL	180.6	SB/WS #1	1a,3a,4b								
fig. 90			SB/WS #2									
FLOYD	US 23 & MT. PKY	15.609	SB/ #1									
fig. n/a			SB/ #2									
			NB/ #1				2a				5a	
			NB/ #2									
JEFFERSON fig. n/a	US 60 RAMP	19.939										
JEFFERSON	US 60	19.939	#1									
fig. n/a			#2									
FAYETTE fig. n/a	JEFF. ST.		S. END						7a	4a		
BULLITT fig. n/a	I-65 & RR	112	NB/EW									

DISTRESS

- 1. VERT. DISP.
- 2. HORIZ. DISP.
- 3. FORWARD DISP.

- 4. CRACKING
- 5. SPALLING
- 6. CORNER OF APRON BROKEN

- 7. STAINING
- 8. BACKWARD DISP.
- 9. MIGRATION OF FINES

SIGNIFICANCE OF DISTRESS

- A = SLIGHT
- B = MODERATE
- C = SEVERE

TABLE 17 CONTINUED. M.S.E. RETAINING WALL (BRIDGE ABUTMENT WING WALL)

LOCATION				SECTION								
COUNTY	RT	MP	DIR	1	2	3	4	5	6	7	8	9
BULLITT	I-65 & RR	112	NB/W									
fig. n/a			SB/E									
			SB/W									
				DISTRESS OBSERVED AVG. (%)								
				1a=7%	4a=4%	1a=7%	1a=4%	4a=4%	2a=4%	1a=4%	4a=4%	7a=4%
				3a=4%		2a=4%	2a=4%	5a=4%	7a=4%	4a=4%	5a=4%	
				3b=4%			6a=4%					
				4b=7%								
				6a=4%								

DISTRESS

- 1. VERT. DISP.
- 2. HORIZ. DISP.
- 3. FORWARD DISP.

- 4. CRACKING
- 5. SPALLING
- 6. CORNER OF APRON BROKEN

- 7. STAINING
- 8. BACKWARD DISP.
- 9. MIGRATION OF FINES

SIGNIFICANCE OF DISTRESS

- A = SLIGHT
- B = MODERATE
- C = SEVERE

TABLE 18. M.S.E. RETAINING WALL (CLOSED BRIDGE ABUTMENT)

LOCATION				SECTION								
				OBSERVED DISTRESS								
COUNTY	RT	MP	DIR	1	2	3	4	5	6	7	8	9
JEFFERSON fig. n/a	264 & 60 RAMP	19.939	WB									
JEFFERSON fig. n/a	US 60 RAMP	19.939	WB									
JEFFERSON fig. 91	264 & TAYL	9.233	WB							9a		
			EB	3a						9a	9a	9a
BOONE fig. 82,83	75 & MALL	180.6	SB/ES #2									
			SB/ES #1	4c,		4b,						
			SB/WS#2	4b				5b				
JEFFERSON fig. n/a	264 & KY 155	17.163	WB									
			EB							3a,4a		
JEFFERSON fig. n/a	264 & KY 1932	18.049	WB									
			EB	4b								

DISTRESS

- | | | |
|------------------|---------------------------|-----------------------|
| 1. VERT. DISP. | 4. CRACKING | 7. STAINING |
| 2. HORIZ. DISP. | 5. SPALLING | 8. BACKWARD DISP. |
| 3. FORWARD DISP. | 6. CORNER OF APRON BROKEN | 9. MIGRATION OF FINES |

SIGNIFICANCE OF DISTRESS

- A = SLIGHT
 B = MODERATE
 C = SEVERE

TABLE 19. M.S.E. RETAINING WALL (BRIDGE ABUTMENT) RETURN WALLS

LOCATION				SECTION								
				OBSERVED DISTRESS								
COUNTY	RT	MP	DIR	1	2	3	4	5	6	7	8	9
KENTON fig. 95a,b,96	1-275 RAMP	0.2	S.E. SIDE	1b,3a,4a, 7a			4b,7a			4a	4a	
94a,b			S.W.SIDE	1b,2b,3a, 4c,7b			1b,2b,3a, 4c,7b			1b,2b,3a, 4c,7b		
			N.W.SIDE	1a,3a,4b								
93a,b			N.E.SIDE	1b,2b,3b, 4c			1b,2b,3b ,4a	4b		1b,2b,3b ,4a		
JEFFERSON fig. n/a	1-264 S.PKY	10.167	S.B.									
BOONE fig. 84	I-75 MALL	180.6	SB/ES	3a			3a					
JEFFERSON fig. n/a	264 & KY 31	15.824	N.B. #1									
			N.B. #2									
			S.B. #1									
			S.B. #2									
JEFFERSON fig. n/a	264 & KY155	17.163	E. SIDE						4b			

DISTRESS

- 1. VERT. DISP.
- 2. HORIZ. DISP.
- 3. FORWARD DISP.

- 4. CRACKING
- 5. SPALLING
- 6. CORNER OF APRON BROKEN

- 7. STAINING
- 8. BACKWARD DISP.
- 9. MIGRATION OF FINES

SIGNIFICANCE OF DISTRESS

- A = SLIGHT
- B = MODERATE
- C = SEVERE

TABLE 19 CONTINUED. M.S.E. RETAINING WALL (BRIDGE ABUTMENT) RETURN WALLS

LOCATION				SECTION								
				OBSERVED DISTRESS								
COUNTY	RT	MP	DIR	1	2	3	4	5	6	7	8	9
JEFFERSON fig. n/a	264 & KY155	17.163	W. SIDE									
JEFFERSON fig. n/a	264 & POP. LEV	13.491	WB/ES									
FAYETTE	JEFF. ST.		SE/ES	4b	4b,3b		4b	4c,5c		4b,7b	4b,7b	
JEFFERSON	264 & 60	19.939	W.B.				4a					
FAYETTE	JEFF. ST.		N/WS									
fig. n/a			N/ES	4c,7c								
JEFFERSON fig. 90	264 & TAYL	9.233	WB/NS	4b	4b	4b						
			WB/SS	4a								
			EB/NS	4a								
			EB/SS	4b,	4b	4b						
JEFFERSON fig. n/a	264 & BROWN				4a		4a					
JEFFERSON fig. n/a	264 & BROWN				4a				4a	4a		4a

DISTRESS

- 1. VERT. DISP.
- 2. HORIZ. DISP.
- 3. FORWARD DISP.

- 4. CRACKING
- 5. SPALLING
- 6. CORNER OF APRON BROKEN

- 7. STAINING
- 8. BACKWARD DISP.
- 9. MIGRATION OF FINES

SIGNIFICANCE OF DISTRESS

- A = SLIGHT
- B = MODERATE
- C = SEVERE

TABLE 19 CONTINUED. M.S.E. RETAINING WALL (BRIDGE ABUTMENT) RETURN WALLS

				SECTION								
				1	2	3	4	5	6	7	8	9
				DISTRESS OBSERVED AVG. (%)								
				1a=4%	3a=4%	4b=9%	1b=9%	4b=4%	4a=4%	1b=9%	4a=4%	4a=4%
				1b=13%	4a=9%		2b=9%	4c=4%	4b=4%	2b=9%	4b=4%	
				2b=9%	4b=13%		3a=9%	5c=4%		3a=4%	7b=4%	
				3a=21%			3b=4%			3b=4%		
				3b=4%			4a=13%			4a=9%		
				4a=13%			4b=9%			4b=4%		
				4b=17%			4c=4%			4c=4%		
				4c=13%			7a=4%			7b=9%		
				7a=4%			7b=9%					
				7b=4%								
				7c=4%								

DISTRESS

- 1. VERT. DISP.
- 2. HORIZ. DISP.
- 3. FORWARD DISP.

- 4. CRACKING
- 5. SPALLING
- 6. CORNER OF APRON BROKEN

- 7. STAINING
- 8. BACKWARD DISP.
- 9. MIGRATION OF FINES

SIGNIFICANCE OF DISTRESS

- A = SLIGHT
- B = MODERATE
- C = SEVERE

TABLE 20: M.S.E. EARTH RETENTION WALL

LOCATION				SECTION								
				OBSERVED DISTRESS								
COUNTY	RT	MP	DIR	1	2	3	4	5	6	7	8	9
KENTON fig. 100	I-75 & KY8	191.3	SB/ES	5a								
			SB/WS	3a	4b						4a,7a	
JEFFERSON fig. n/a	I-64 & 264	19.070	EB	4b,7a	2a						5a	3a
JEFFERSON fig. n/a	I-64 & 264	19.939	WB				4b					
FLOYD fig. n/a	US 23 & KY 2225	15.95	N									
				DISTRESS OBSERVED AVG. (%)								
				3a=20%	2a=20%		4b=20%				4a=20%	3a=20%
				4b=20%	4b=20%						5a=20%	
				5a=20%							7a=20%	
				7a=20%								

DISTRESS

- | | | |
|------------------|---------------------------|-----------------------|
| 1. VERT. DISP. | 4. CRACKING | 7. STAINING |
| 2. HORIZ. DISP. | 5. SPALLING | 8. BACKWARD DISP. |
| 3. FORWARD DISP. | 6. CORNER OF APRON BROKEN | 9. MIGRATION OF FINES |

SIGNIFICANCE OF DISTRESS

- A = SLIGHT
 B = MODERATE
 C = SEVERE

2.9 TECHWALL

There were two TechWalls inspected for this evaluation. Both walls were located in Kenton County on the 12 th. street ramp going to I-75 northbound (Figure 101). Both walls have been inspected twice, once in 1995 and again in 1997. In both instances, the TechWalls have appeared to be performing well with the exception of some spalling, staining, and cracking in the precast panels (Figures 102 and 103). Figure 102 shows where possibly an epoxy has been used to patch some of the cracking and spalling noted in one of the precast panels. Figure 103 shows where one of the precast panels has begun to spall and stain.

2.9.1 Discussion

It is believed that the spalled and cracked areas shown in Figure 102 were probably patched shortly after construction. It is uncertain at this time as to what has caused the cracking and spalling. It is possible that the precast panel was defective prior to construction, or this wall might be withstanding larger than anticipated stresses at this point. The stains that were observed in Figures 102 and 103 are believed to have come from water weeping through the panel joints.

2.9.2 Recommendations

It should be stressed that all precast panels be thoroughly inspected prior to placement, and defective materials should be rejected at the job-site. It is recommended that these walls along with any other newly accepted alternative retaining walls be placed under a long-term investigation to monitor experimental features.



Figure 101: TechWall (Kenton County, 12 s.t. ramp to I-75 N.B.)

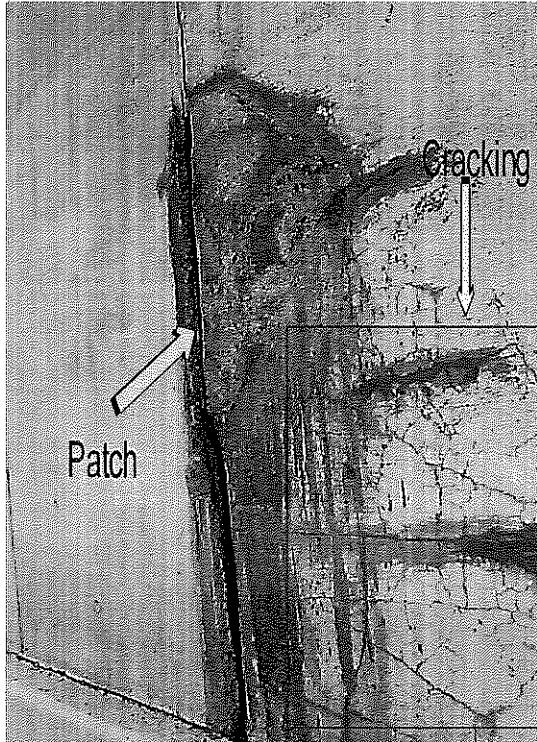

Figure 102: TechWall with Patched Area, Spalling, & Staining. (Kenton County)

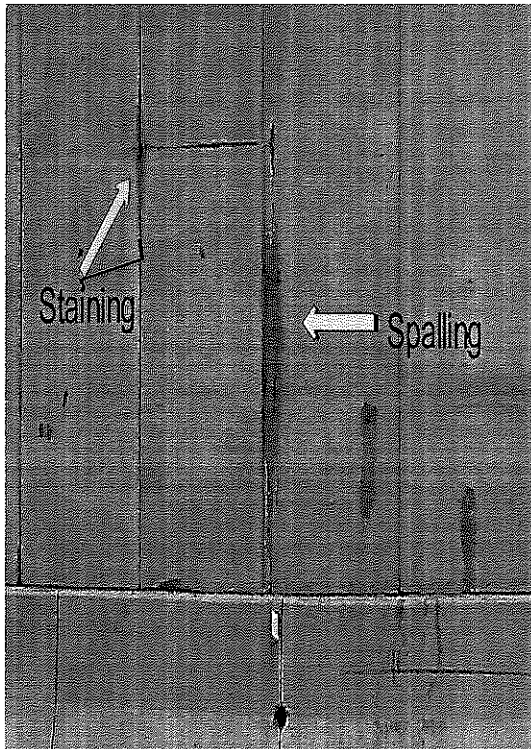

Figure 103: Staining & Spalling between Panel Joints (Kenton County)

2.10 SOUND BARRIERS

There were two types of sound barriers inspected under this study. One sound wall was constructed of bricks (Figure 104), and the other sound wall was constructed using metal sheeting (Figure 105). Both walls have performed well structurally. The effectiveness of the walls to absorb or reflect sound waves was not studied in this project. The only distress that was noted in either of two walls appears to be damage caused by mowers (Figures 106 and 107).

2.10.1 Discussion

The chipped bricks and dented metal in Figures 106 and 107, respectively, could have been avoided if proper care was taken while mowing around these structures. Mowers should be instructed to use greater caution around these walls.

2.10.2 Recommendations

There are no recommendations from a structural standpoint, at this time, for the sound walls. However, it is recommended that mowing crews use greater caution near these structures.



Figure 104: Brick Sound Wall (Jefferson County, I-264)

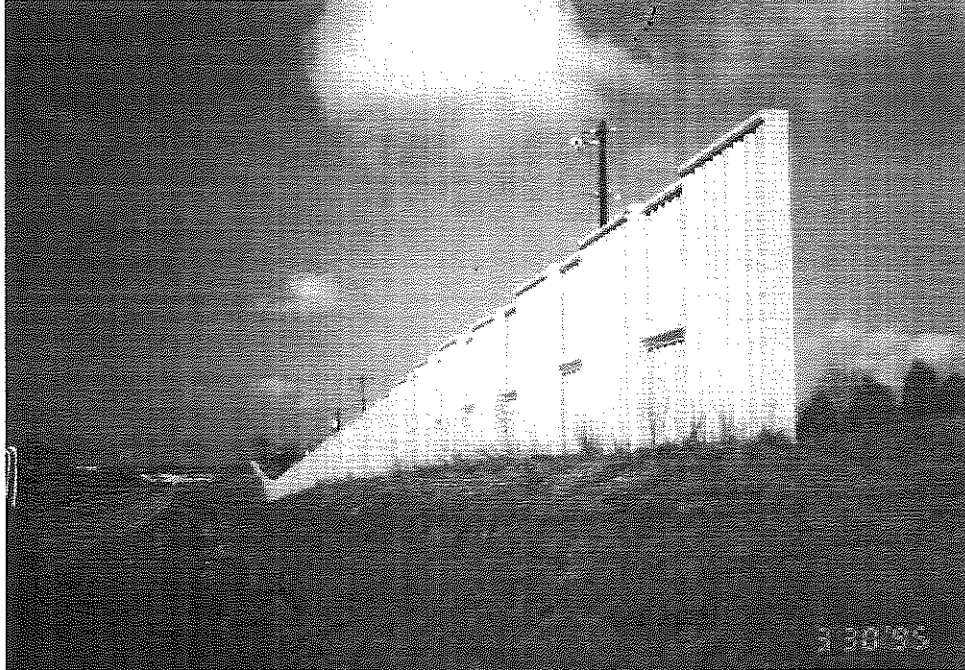

Figure 105: Metal Sound Wall (Scott County, Georgetown Bypass)



Figure 106: Chipped Bricks on Sound Wall Caused by Mower
(Jefferson County, I-264)



Figure 107: Dented Metal on Sound Wall Caused by Mowers (Scott County)

3.0

SUMMARY AND RECOMMENDATIONS

The following paragraphs summarize findings and list recommendations.

The four concrete crib walls inspected have been performing well, structurally. Migration of the interior backfill has been accelerated in two of the inspected walls due to uncontrolled surface runoff up-grade from the walls. It is recommended that surface runoff be diverted away from all retaining-wall structures. Also, in these particular wall structures, the use of non-erodible granular backfill is to be used to prevent migration of backfill material. If the backfill is classified as erodible or unstable then it is to be protected by a geotextile fabric.

The fifty-two culvert wing walls inspected have been performing well. The slight-to-moderate cracking that has occurred in sections two, five, and eight may be largely attributed to shrinkage cracking. This shrinkage cracking can be controlled in future wall systems by making a vertical saw cut down the middle of the wall or by the use of more expansion and contraction joints. In addition to the change mentioned above, maintenance crews are to periodically check the inlet and outlet ends of the culvert for buildup of debris or vegetation, and take any necessary actions to clean up obstructions blocking the culvert.

Four of the five metal bin walls have been performing well with the exception of some spot rusting. This is to be corrected with rust resistant paint. The other metal bin wall which was located on US 25E in Knox County has been experiencing vertical settlement in sections two, five, and eight. Although severe buckling has occurred in some of the vertical supports, this wall does not appear to be in immediate danger of collapsing. However, further inspection and monitoring are to be performed on this particular wall.

There were five Gabion walls inspected for this study. Three of the Gabion walls were state owned and maintained, and the other two were privately owned. Two of the three state walls were not built in compliance with the Kentucky Standard Drawing (BGX-008-04) (Appendix B). In both cases, the Gabion walls have started to sag and bulge in sections two, five, and eight. However, Kentucky Standard Drawing (BGX-008-04) is no longer effective. Future Gabion wall construction shall be constructed in compliance with the new Kentucky State Specifications and Standard Drawings available in 1998. It is further recommended that Gabion walls without a crushed stone backfill, or a backfill passing the 100-mm (4-inch) sieve, that a geotextile shall be placed between the backfill and the Gabion wall.

There were fifty-one concrete retaining walls inspected. Concrete walls used for bridge approach fill retaining walls have suffered the most severe recurring distress among the five different wall categories. Consideration is to be given to reinforcing the backfill of approach fills, and wall drains are to be placed with care. To insure proper drainage at bridge ends, the wall drains are to be inspected with a pipeline camera during the construction phase.

In the stand-alone concrete soil-retention walls, vertical key-joints are not to be used in future wall construction. Instead, the vertical joints are to be filled with expansive joint material. To control random shrinkage cracking above weep holes in the rigid concrete walls, vertical saw cuts are to be made up the face of the wall above the weep holes. Lastly, use construction grade grout

to fill holes left behind from form work.

Of the ten tiedback walls inspected in this study, the group that had a cast-in-place wall in front of the tiedback wall has performed the best. The two tiedback walls that have used clips to hold the timber lagging in place are in need of immediate maintenance. This method of construction is not to be used in future tiedback wall construction. The method of placing timber lagging between the webs of the H-Piles appears to be a good alternative to using the clips. However, the tiedback walls that used this type of construction are relatively new and are to be monitored further.

Several problems were noted with the seventy-seven M.S.E. walls. Settlement of the leveling pads was noted in several of the inspected M.S.E. wing walls, which may be attributed to poor soil compaction. Cracking in M.S.E. wall panels on return walls and bridge abutments has developed due to precast panels or cast-in-place blocks located between the bridge deck and the M.S.E. wall. In future M.S.E. wall construction, these precast panels or cast-in-place blocks are not to be used to bridge the two structures. Drainage was an additional problem that was noted during inspection of M.S.E. bridge abutment and return walls. Water is to be diverted away from the reinforced approach fill. In areas where wall drains are installed in the approach fill, a miniature pipeline camera should be used to inspect the integrity of drainage system during construction. Also, water is not to be discharged from headwalls directly behind any retaining wall structure. Lastly, use geotextile fabrics in M.S.E. wall construction as outlined in Special Provision No. 66L (94) (Appendix D).

There were two TechWalls inspected for this study. The TechWall is one of the accepted alternative walls selected by the Kentucky Department of Highways. However, this particular wall type has not been used very frequently in Kentucky. The two TechWalls that were inspected have already shown signs of distress. Newly accepted walls such as the TechWalls, and other retaining walls are to be thoroughly monitored during construction. Long-term monitoring should be performed on newly accepted alternative wall structures.

Two types of sound walls were inspected--brick and sheet-metal. Both wall types have performed well structurally. Mowers have been the only source of damage.

3.1 OVERALL RECOMMENDATIONS

Several walls that were evaluated had significant problems and must be repaired. It is recommended that retaining wall structures be inspected annually by maintenance forces. It is apparent from this study that drainage plays a major role in the long-term performance of these structures. Past edge drain research indicates that 20 to 50 percent of edge drain outlets are not fully functional. It is likely that these percentages also are applicable to bridge-end drains. It is recommended that bridge-end drains be inspected during construction. It is also recommended that a full-scale study be conducted on the performance of bridge-end drainage and to evaluate the lateral earth pressures on return walls.

**SECTION 610 – CONCRETE BOX OR ARCH CULVERTS,
RETAINING WALLS, AND HEADWALLS**

- 610.01 Description
- 610.02 Materials
- 610.03 General
- 610.04 Footings
- 610.05 Culvert Inverts, Aprons, and Curtain Walls
- 610.06 Retaining Walls
- 610.07 Drainage
- 610.08 Placing Concrete
- 610.09 Removing Forms
- 610.10 Surface Finish and Placing Fill
- 610.11 Extensions to Existing Culverts
- 610.12 Method of Measurement
- 610.13 Basis of Payment

610.01 Description. All concrete box or arch culverts; headwalls for pipe, box, or arch culverts; and concrete retaining walls shall be built as indicated, in reasonably close conformity to line, grade, dimensions, and design shown on the plans, and in accordance with these specifications.

Box culverts constructed using precast sections shall meet the requirements of Section 616.

MATERIALS

610.02 Materials. Materials shall meet requirements specified in the following Sections.

Concrete	601
Steel Reinforcement	602
Clay Pipe	810.02.16
Concrete Pipe	810.02.01
Coarse Aggregate	805
Joint Materials	807

CONSTRUCTION REQUIREMENTS

610.03 General. All concrete construction shall conform to the applicable requirements of Section 601.

610.04 Footings. Footings shall be constructed to the elevation shown on the plans, but such depth may be increased when it is determined by the Engineer that the increase is necessary to provide sufficient bearing or to prevent undermining. Footing elevations should only be raised when solid rock is encountered at elevations above those shown.

The outside face of all footings of concrete headwalls for pipe, box, or arch culverts shall be formed full depth of the footing.

Whenever the natural foundation material is insufficiently stable to support the structure or whenever it is anticipated that high water may cause excessive erosion around the footings, the Engineer may order extra work performed as necessary to provide the structure with adequate support or protection. Payment for such work shall be made in accordance with Section 109.04, Extra Work.

When the condition of excavation for footings is otherwise satisfactory but is such that concrete cannot be placed without mud becoming mixed with the concrete, special operations shall be performed to remedy the condition. The Contractor shall place sufficient sand, coarse aggregate, or a combination of aggregates, or shall place a layer of roofing felt or similar material, to prevent infiltration of mud; or the entire mass of mud shall be removed and replaced with stable material. No direct payment will be allowed for the cost of these materials and labor.

610.05 Culvert Inverts, Aprons, Curtain Walls, and Headwalls. All culverts, except those founded on solid rock, shall be constructed with a substantial concrete slab through the invert or stream bed. This pavement shall terminate at each end of the culvert in apron walls, or curtain walls, or cutoff walls carried to a depth that will eliminate danger of undermining. Inverts for concrete culverts shall be paved with a reinforced concrete slab, unless otherwise directed.

Apron or cutoff walls shall, in general, be carried down at both ends to the depth shown, but may be ordered to additional depth necessary to prevent undermining. The outside face of inlet and outlet concrete apron or cutoff walls for single span or multiple span culverts shall be formed for the full depth of the apron or cutoff walls. Should it be necessary to form the back face and/or the end of apron or cutoff walls due to the nature of the material encountered in the excavation, necessary structure excavation therefor will be paid for but will not exceed the same limits as set out in the specifications for payment outside the neat lines of the footings.

The Engineer may direct the space between wings to be paved. In this event, the apron walls will extend in a straight line between the ends of the wings, or at such locations as may afford the best protection.

When headwalls for pipe culverts are located at the shoulder, the top of the headwalls shall be parallel to the shoulder line for both line and grade. Standard drawings for pipe culvert headwalls list dimensions from the face of concrete to steel reinforcement as clear distances and dimensions for bar spacings as center to center of bars. Precast concrete pipe headwalls shall conform to the requirements of Section 710.

610.06 Retaining Walls. Gravity type or nonreinforced retaining walls may be constructed of Class B Concrete and shall be constructed in accordance with standard drawing no. RGX-002, unless specified otherwise. Class A

concrete may be used at the Contractor's option, but no change in contract price will be allowed.

The base width shall be 1/2 of the vertical height of the wall and the top width shall be 305 mm (12 inches). Transverse expansion joints 12.7 mm (1/2 inch) in width shall be placed at intervals of not over 9.14 m (30 feet) throughout the length of retaining walls and expansion joint material shall be placed therein. All exposed edges shall be beveled 22.2 mm (7/8 inch). The walls shall not be surcharged except in special cases wherein special drawings will be furnished. When the height is such that it is not practicable to pour the wall to full height in one operation, construction joints shall be truly horizontal, and adequate bond shall be provided between the sections by means of keys formed by beveled timbers. Where necessary to provide construction joints in the length of the wall, such joints shall be truly vertical and adequate bond shall be provided between the sections by means of shear keys formed by beveled timbers.

Reinforced concrete retaining walls shall be constructed of Class A Concrete and shall be constructed as shown on the plans.

610.07 Drainage. Weep holes consisting of 102-millimeter (4-inch) pipe or formed to 102 mm (4 inches) in diameter shall be placed at intervals not to exceed 7.62 m (25 feet) in retaining walls, nor exceeding 3.05 m (10 feet) in box culverts having a clear opening height of 1.83 m (6 feet) or more. The outlet invert elevation of the weep holes shall correspond to the elevation to which earth will be placed at the outside retaining wall face. The outlet invert elevation of weep holes in box culverts shall be placed 102 mm (4 inches) above the flowline of the culvert. Adequate provision shall be made for thorough drainage of backfill and embankment as specified in Section 206.08. More elaborate drainage systems will be required when shown on the plans.

610.08 Placing Concrete. Concrete shall be placed as specified in Section 601.

The base slab or footings shall be placed and allowed to harden before the remainder of the structure is constructed. When required, suitable provision shall be made for bonding the walls to the base by means of longitudinal keys formed by insertion and subsequent removal of beveled timbers. Base slabs, footings, and apron walls shall be constructed as monolithic units, when practicable. When construction joints are necessary, they shall be placed at right angles to the culvert barrel or retaining wall and suitable provision made for bonding adjacent sections by means of keys formed by beveled timbers.

Before concrete is placed in the walls, the footings shall be thoroughly cleaned of all debris, or other extraneous material and the surface carefully chipped and roughened in accordance with the method of bonding construction joints, as specified under Section 601.18.

In the construction of all box culverts having a clear height of 1.52 m (5 feet) or more, concrete in the side walls shall be placed and allowed to set before the top slab is placed.

For culverts having a clear height of less than 1.52 m (5 feet), the culvert may be poured monolithic when the Contractor so desires. When this method of construction is used, any necessary construction joints shall be vertical and at right angles to the axis of the culverts.

Each wingwall shall be constructed as a monolithic unit. Construction joints, where unavoidable and when not shown, shall be horizontal.

610.09 Removing Forms. The removal of forms shall be governed by the applicable provisions of Section 601.22. The removal of forms from arch culverts shall conform to the requirements specified in Section 608.22, Part A.

610.10 Surface Finish and Placing Fill. Surfaces shall be finished in accordance with the requirements of Section 601.26. Top slabs of box culverts to be used as the wearing surface for traffic shall be textured as specified in Section 609.13 and shall meet roadway rideability requirements of section 501.24 or bridge slab requirements of Section 609.11.

Backfill or embankment shall not be placed about culverts, retaining walls, and headwalls until permission is given by the Engineer.

Backfill shall be constructed as specified in Section 206.08. Embankment shall be constructed as specified in Section 207.06.

610.11 Extensions to Existing Culverts. Extensions shall be constructed as designated on the plans. Pertinent requirements in the foregoing paragraphs shall apply to extensions of existing culverts. Extensions shall conform to the lines and grades established and to dimensions shown.

Portions of the existing structure designated to be removed shall be removed in a manner to provide a neat junction with the extension and leave undamaged that portion of the existing structure that is to remain in service. The Engineer may require sawing of the existing concrete to a depth sufficient to ensure a neat joint, when the joint will be exposed in the finished work. Any damage to the existing structure shall be repaired by the Contractor at his expense. All silt or other debris that may have collected within the barrel of the existing structure shall be removed and disposed of by the Contractor, payment for which shall be incidental to the work.

Where extensions to existing concrete structures are required, the walls and top and bottom slabs shall be removed for a distance of at least 610 mm (24 inches) to a plane paralleling the load-carrying steel. Projecting reinforcing bars in the existing structure shall be left undamaged and shall be tied to reinforcing bars placed in the formed extension.

610.12 Method of Measurement. Concrete, steel reinforcement, and structure excavation for box or arch culverts, retaining walls and headwalls, except pipe headwalls, will be measured as specified in Sections 601.28, 602.10, and 206.10, respectively. Pipe headwalls will be measured as specified in Section 611.11.

610.13 Basis of Payment. Concrete, steel reinforcement and structure excavation for box or arch culverts, retaining walls, and headwalls, except pipe headwalls, and removal of portions of existing structures will be paid for at the unit price bid for the items in accordance with provisions of Sections 601.29, 602.11, 206.11, and 203.10, respectively. Pipe headwalls will be paid for as specified in Section 611.12. No payment will be made for excavation or backfill in excess of the limits described in these specifications that may be necessary to achieve safe working conditions.

Payment will be made under:

<i>Code</i>	<i>Pay Item</i>	<i>Pay Unit</i>
—	Concrete	See Section 601.29
—	Steel Reinforcement	See Section 602.11
—	Structure Excavation	See Section 206.11
—	Pipe Headwalls	See Section 611.12
—	Removal of Portion of Existing Structure	See Section 203.10

SECTION 742 – GABION RETAINING WALLS

- 742.01 Description
- 742.02 Materials
- 742.03 General
- 742.04 Method of Measurement
- 742.05 Basis of Payment

742.01 Description. This work shall consist of furnishing and installing wire mesh gabion baskets and furnishing and placing interior fill material, all in accordance with these specifications, and in reasonably close conformity with the lines, grades, and dimensions shown on the plans and standard drawing.

MATERIALS

742.02 Materials. Gabion baskets shall meet the requirements of Section 813.15.

Stone used to fill the gabions shall meet the general requirements of Section 805. The gradation of the stone shall be such that 100 percent will pass through a 305-millimeter by 305-millimeter (12-inch by 12-inch) square opening, and 100 percent will be retained on a 100 millimeter (4-inch) sieve.

CONSTRUCTION REQUIREMENTS

742.03 General. The foundation shall be accurately prepared to accept the gabions as shown on the plans, and shall be approved before any gabions are placed.

Individual gabion baskets shall be assembled by placing flat on the ground, flattening any kinks or bends, and then erecting the sides, ends and diaphragms. All creases shall be in the correct position and the tops of all sides level. The 4 corners of the gabion shall be laced together with alternating single and double loops at 127-millimeter (5-inch) intervals, with both ends of the lacing wire secured by looping and twisting. Internal diaphragms shall be installed, and laced in a similar way. Individual assembled baskets shall be placed in their proper location and all adjoining gabions connected. This connection shall be accomplished using individual tie wires looped and twisted at approximately 76-millimeter (3-inch) intervals along the entire perimeter of their contact surfaces.

Each course of gabions shall be stretched to proper alignment by partially filling the first gabion in line for anchorage, and stretching the connected gabions using a come-along or other means of at least 0.9 metric ton (one ton) capacity. Gabions shall be kept in tension while being filled. Gabion joints shall be controlled to avoid any unravelling. Gabions shall be carefully filled in 0.30-meter (one-foot) layers, in a manner that will minimize voids. Two connecting wires shall be placed in each direction between each layer in all cells

by looping lacing wire around 2 mesh openings in the front and back face, and in the ends and diaphragms. The ends of the connecting wires shall be securely twisted to prevent their loosening under tension. Cells in each course of gabions shall be filled in stages, i.e. at no time shall any cell be filled to a depth exceeding 0.30 m (one foot) more than the adjoining cell. The last layer of stone shall be leveled with the top of the gabion to allow proper closing of the lid and provide an even surface for the next course. Lids shall be stretched tight over the stone fill using crowbars or similar methods, until the lid meets the edges of the front and ends. The lid shall be tightly tied along all edges, ends, and diaphragms in the same manner as required for connecting adjoining gabions. Succeeding courses or tiers shall be placed and connected as specified for the first course. Baskets for succeeding courses shall be placed so vertical joints are offset at least 457 mm (18 inches) from course to course, unless otherwise shown on the plans or standard drawings. Gabions shall be placed as headers or stretchers in accordance with the standard drawings. Each course of gabions shall be tied to the lower course after stretching but before filling, by use of individual tie wires looped and twisted at approximately 76-millimeter (3-inch) spacing along all edges and diaphragms. Vertical edges at each end of the wall that are not connected to an adjoining gabion shall be reinforced by looping and twisting individual tie wires at approximately 76-millimeter (3-inch) spacing the full length of such edges.

Care shall be exercised during all gabion wall construction to ensure the stone fill is firmly in place, bulging or distortion of the filled baskets is minimal, and all lacing and tying is thoroughly wound, looped and twisted to preclude loosening in service.

742.04 Method of Measurement. Gabion retaining walls will be measured in cubic meters (cubic yards) complete and accepted in the final work. The volume will be calculated using dimensions shown on the plans or as directed in writing.

Structure excavation, as classified, will be measured in cubic yards for the volume actually excavated from within the limits bounded by vertical planes one foot outside the neat lines of the base of the gabion retaining walls at the ends and front face, and a plane one foot outside and parallel to the back face of the lowest gabion. Measurement will be made, within the designated limits, between the original ground and bottom of the excavated pit, except in cut sections where the finished cross section will govern.

742.05 Basis of Payment. The accepted quantity of gabion retaining wall will be paid for at the contract unit price per cubic meter (cubic yard). The accepted quantities of structure excavation, as classified, will be paid for as specified in Section 206.11. Payment shall be full compensation for all materials, equipment, labor, and incidentals necessary to complete the work.

Payment will be made under:

<i>Code</i>	<i>Pay Item</i>	<i>Pay Unit</i>
2610	Retaining Wall, Gabion	Cubic Meter or Cubic Yard
—	Structure Excavation, as classified	See Section 206.11

(B) *Wire Mesh for Mattress Units.* The wire mesh shall permit elongation equivalent to a minimum of 10 percent of the length of the section under test without reducing the diameter or tensile strength of individual wire.

The maximum linear dimension of the mesh opening shall not exceed 83 mm (3 1/4 inches) and the area of the mesh opening shall not exceed 3 870.96 mm² (6 square inches).

(C) *Mattress Units.* Wire mattress units shall be fabricated in such a manner that the base, sides, and ends can be assembled at the construction site into a rectangular unit of the specified size. The body of the mattress units shall be of single unit construction; the bottom, ends, and sides formed of a single woven mesh unit. The top shall be a separate woven unit of the same mesh and wire specifications as the body.

The mattress units shall be subdivided into compartments a maximum of .91 m (3 feet) long extending over the full width of the mattress unit by the insertion of diaphragms made of the same mesh as the rest of the mattress unit. The diaphragms shall be factory secured in proper position on the bottom with a continuous spiral wire, in such a manner that no additional tying at this joint will be necessary.

All perimeter edges of the mesh forming the mattress unit shall be securely selvaged so that the joints formed by tying the selvage have at least the same strength as the body of the mesh.

Lacing wire shall be supplied in sufficient quantity so that all sides, ends and diaphragms may be securely fastened together, and the top may be securely fastened to all sides, ends, and diaphragms. The connecting wire shall meet or exceed the same specifications as the wire specified for the mesh.

Mattress units shall be supplied in the lengths and widths designated by the plans or required by the Engineer. Width of all mattresses shall be uniform, and shall be within plus or minus 3 percent of the ordered width.

813.14.02 Acceptance. The Engineer will sample each shipment for testing of the wire size and zinc coating, and other tests as deemed necessary. Acceptance will be based on laboratory testing and visual inspection by the Engineer on the project.

813.15 Gabion Baskets.

813.15.01 Requirements.

(A) *Wire for Gabion Baskets.* Steel wire sizes and zinc coatings shall be as follows:

ITEM	MINIMUM DIAMETER mm (inches)	MINIMUM COATING kg/m ² (ounces per S.F.)
Mesh wire — baskets and diaphragms	2.896 (0.114)	2.44 (0.80)
Selvage Wire	3.810 (0.150)	2.44 (0.80)
Lacing and Connecting wire	2.108 (0.083)	2.14 (0.70)

Zinc coating will be tested in accordance with ASTM A 90.

(B) Wire Mesh for Gabion Baskets. The mesh shall be made of the specified wire, triple twisted, forming a uniform hexagonal mesh pattern of approximately 83 mm by 114 mm (3 1/4 inch by 4 1/2 inch) nominal openings.

(C) Gabion Baskets. The mesh shall be fabricated into baskets of the dimensions required by the contract. The length, width, and height of the gabions as shown in the plans are minimum dimensions acceptable and gabions of slightly greater dimensions will be allowed.

When the gabion length exceeds its width, it shall be supplied with diaphragms to form individual cells of equal length and width. The diaphragms shall be of the same material composition as the gabion.

Tying and connecting wire shall be supplied in sufficient quantity so that all required tying, connecting, and lacing can be performed. When gabion baskets are purchased directly by the Department, tying and connecting wire shall be supplied in a minimum amount of 8 percent of the weight of the gabions.

813.15.02 Acceptance. The Engineer will sample each shipment for testing of the wire size, zinc coating, and other tests as deemed necessary. Acceptance will be based on laboratory testing and visual inspection by the Engineer on the project.

SECTION 701 – CONCRETE CRIB-TYPE RETAINING WALLS

- 701.01 Description
- 701.02 Materials
- 701.03 Foundation
- 701.04 Concrete Cribbing
- 701.05 Interior Fill and Backfill
- 701.06 Method of Measurement
- 701.07 Basis of Payment

701.01 Description. This work shall consist of furnishing and installing concrete crib members and furnishing and placing the interior fill material all in accordance with these specifications and in reasonably close conformity with the lines, grades, and dimensions shown on the plans. The crib members shall be reinforced concrete and shall comply with requirements hereinafter specified.

MATERIALS

701.02 Materials. Concrete crib members shall be of Class D Concrete cast in conformance with general requirements specified in Section 605. Materials shall meet requirements specified under the following Sections.

Miscellaneous Metals	813
Concrete, Class D	601
Steel Reinforcement	602
Perforated Pipe	705.02

Interior fill for closed face concrete cribbing shall be granular material approved by the Engineer, and may be any of the following alternates providing none contains more than 15 percent passing the 150 μ m (No. 100) sieve:

- (1) Well graded or uniformly graded crushed or uncrushed gravel.
- (2) Crushed stone or crushed slag up to 76 mm (3 inches) maximum size.
- (3) Finely shot limestone, sandstone, or rock-like shale (SDI 95 or greater by KM 64-513) up to 76 mm (3 inches) maximum size.
- (4) Well graded or uniformly graded natural or crushed sand.

The granular material shall contain no more than 5 percent dirt and/or soil-like shale (SDI 50 or less by KM 64-513), as determined by visual inspection by the Engineer.

Natural sand, crushed sand, or crushed aggregate smaller than No. 57 shall not be used to fill open face concrete cribbing.

The 0.61 m (2.0 feet) of minimum soil cover, as shown on the standard drawings, shall be silt-clay materials (more than 35 percent passing 0.075 mm).

CONSTRUCTION REQUIREMENTS

701.03 Foundation. The foundation or bed for cribbing shall be excavated true to the established grade, shall be firm, and shall be approved before any crib work is placed.

701.04 Concrete Cribbing. In general, transverse concrete sill members shall be used to support the lower cribbing course. Crib members shall be handled and erected in a manner to avoid damage. Any members that are cracked or otherwise damaged shall be replaced at the Contractor's expense. Each member shall be secured by means of approved interlock features of the cribbing. Double rows of headers shall be placed at approximately 29.26-m (96-foot) intervals to provide for differential expansion and settlement along the wall. Closed face end headers and closed face stretchers shall be used when shown on the plans. The same type cribbing and construction shall be used throughout the project.

701.05 Interior Fill and Backfill. Filling for the interior of the crib shall progress simultaneously with erection of the cribbing and shall be of approved materials placed in layers not to exceed 305 mm (12 inches) loose thickness or as shown on the plans, tamped and consolidated to the satisfaction of the Engineer. Two hundred three-millimeter (eight-inch) perforated pipe shall be installed behind each retaining wall as directed.

Backfilling around and behind the crib wall shall be done as set out in Section 206.08. Filling and backfilling operations and equipment shall be such that alignment of the wall is not disturbed.

Geotextile fabric meeting the requirements of Section 845 for Type II shall be placed between the interior fill and the soil cover. The fabric will not be paid for separately, but will be considered incidental to the interior fill.

701.06 Method of Measurement. Cribbing will be measured in square meters (square feet) complete and accepted in the final work. The gross area lying in a plane of the outside front face of the structure as shown on the plans or as directed in writing will be measured. Perforated pipe will be measured as specified in Section 705.04.

Structure excavation, as classified, will be measured in cubic yards for the volume actually excavated from within the limits bounded by vertical planes one foot outside the neat lines of the crib wall base at the ends and the front face and a plane one foot outside and parallel to the back face of the lowest cell. Measurements will be made, within the designated limits, between the original ground and bottom of the excavated pit, except in cut sections where the finished cross section will govern.

The interior fill will be measured in cubic yards complete and accepted in the final work. Measurement will be made of the actual volume compacted in place, within the crib and computed from the interior dimensions shown on the plans or as directed in writing.

701.07 Basis of Payment. The accepted quantities of cribbing will be paid for at the contract unit price per square meter (square foot). The accepted quantities of structure excavation, as classified, will be paid for as specified in Section 206.11. Perforated pipe will be paid for as specified in Section 705.05.

The accepted quantities of interior fill will be paid for at the contract unit price per cubic yard. Payment shall be full compensation for all materials, equipment, labor, and incidentals necessary to complete the work.

Payment will be made under:

<i>Code</i>	<i>Pay Item</i>	<i>Pay Unit</i>
8031	Retaining Wall, Concrete Cribbing	Square Meter or Square Foot
—	Structure Excavation, as Classified	See Section 206.11
2753	Interior Fill for Cribbing	Cubic Meter or Cubic Yard
—	Perforated Pipe	See Section 705.05

SECTION 702 – METAL BIN-TYPE RETAINING WALLS

- 702.01 Description
- 702.02 Materials
- 702.03 General
- 702.04 Method of Measurement
- 702.05 Basis of Payment

702.01 Description. This work shall consist of furnishing and installing metal bin-type retaining walls and placing interior materials all in accordance with these specifications and in reasonably close conformity with the lines, grades, and dimensions shown on the plans. Metal bin-type retaining walls shall consist of a plurality of pairs of columns, one column of each pair being in the plane of the front of the wall and the other column being in the plane of the rear of the wall, with the pairs of columns spaced longitudinally with overlapping U-shaped tie members. Necessary bolts and appurtenances shall be furnished for complete assembly of units into a continuous closed face wall of connected bins.

Units in the wall shall conform to the dimensions and thicknesses specified and, when assembled, shall present a uniform and workmanlike appearance.

MATERIALS

702.02 Materials. Members shall be of the sizes shown on the plans. The Contractor shall submit shop drawings of the members to be used at least 3 full weeks prior to construction for review. Galvanized bolts for assembly shall be 15.9 mm (5/8 inch) in diameter and shall have a minimum length of 32 mm (1 1/4 inches) measured from the underside of the bolt head. Perforated pipe shall meet requirements of Section 705.02.

Galvanized steel sheets used to fabricate the wall shall conform to ASTM A 444 with respect to base metal analysis and weight of zinc coating only.

Interior fill shall be granular material approved by the Engineer, and may be any of the following alternates providing none contains more than 15 percent passing the 150 μ m (No. 100) sieve:

- (1) Well graded or uniformly graded crushed or uncrushed gravel.
- (2) Crushed stone up to 76 mm (3 inches) maximum size.
- (3) Finely shot limestone, sandstone, or rock-like shale (SDI 95 or greater by KM 64-513) up to 76 mm (3 inches) maximum size.
- (4) Well graded or uniformly graded natural or crushed sand.

The granular material shall contain no more than 5 percent dirt and/or soil-like shale (SDI 50 or less by KM 64-513), as determined by visual inspection by the Engineer.

The 0.61 m (2.0 feet) of minimum soil cover, as shown on the standard drawings, shall be silt-clay materials (more than 35 percent passing 0.075 mm).

CONSTRUCTION REQUIREMENTS

702.03 General. The foundation or bed for the bin wall shall be firm and shall be approved before any of the bin wall is placed. Members shall be erected as shown on the plans. The members shall be handled carefully and any which are damaged shall be removed and new members substituted at the Contractor's expense.

Filling for the interior of the bin wall shall progress simultaneously with erection of the members and shall be of approved material, as shown on the standard drawing, placed in layers not to exceed 305 mm (12 inches) loose thickness or as shown on the plans, tamped and consolidated to the satisfaction of the Engineer.

Two hundred and three-millimeter (eight-inch) perforated pipe shall be placed behind each retaining wall as directed.

Backfilling around and behind the bin-type retaining walls shall be done as specified in Section 206.08. Filling and backfilling operations and equipment shall be such that alignment of the wall is not disturbed.

Geotextile fabric, meeting the requirements of Section 845 for Type II, shall be placed between the interior fill and the soil cover. The geotextile fabric will not be paid for separately, but will be considered incidental to the interior fill.

702.04 Method of Measurement. Metal bin-type retaining walls will be measured in square meters (square feet) complete and accepted in the final work. The area to be measured will be the area lying in the plane of the outside front face of the structure as shown on the plans or as directed in writing.

Structure excavation, as classified, will be measured in cubic meters (cubic yards) for the volume actually excavated from within the limits bounded by vertical planes one foot outside the neat lines of the wall base at the ends and front face and a plane one foot outside and parallel to the back face of the wall. Measurements will be made, within the designated limits, between the original ground and bottom of the excavated pit, except in cut sections where the finished cross section will govern.

Perforated pipe will be measured as specified in Section 705.04.

The interior fill will be measured in cubic meters (cubic yards) complete and accepted in the final work. Measurement will be made of the actual volume compacted in place within the wall and computed from the interior dimensions shown on the plans or as directed in writing.

702.05 Basis of Payment. The accepted quantities of metal bin-type retaining wall will be paid for at the contract unit price per square meter (square foot).

The accepted quantities of structure excavation, as classified, will be paid for as specified in Section 206.11. The accepted quantities of interior fill will be paid for at the contract unit price per cubic meter (cubic yard). Perforated pipe will be paid for as specified in Section 705.05. Payment shall be full compensation for all materials, equipment, labor, and incidentals necessary to complete the work.

Payment will be made under:

<i>Code</i>	<i>Pay Item</i>	<i>Pay Unit</i>
8022	Retaining Wall, Metal Bin	Square Meter or Square Foot
—	Structure Excavation,	
	as Classified	See Section 206.11
—	Interior Fill for Bin-Type	
	Retaining Walls	Cubic Meter or Cubic Yard
—	Perforated Pipe	See Section 705.05

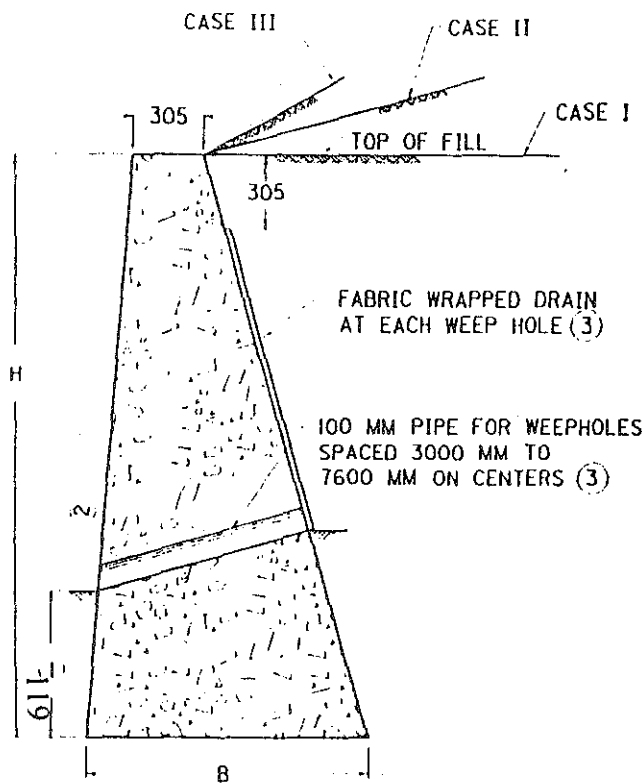

CASE I, CASE II, AND CASE III

H	B	END AREA SQ. METER	VOLUME CU. M. /M
CASE I OR II OR III			
915	460	0.348	0.348
1065	535	0.447	0.447
1220	610	0.557	0.557
1370	685	0.679	0.679
1525	765	0.813	0.813
1675	840	0.958	0.958
1830	915	1.115	1.115
1980	990	1.283	1.283
2135	1065	1.463	1.463
2285	1145	1.655	1.655
2440	1220	1.858	1.858
2590	1295	2.073	2.073
2745	1370	2.299	2.299
2895	1450	2.537	2.537
CASE I			
3050	1525	2.787	2.787
3200	1600	3.048	3.048
3350	1675	3.32	3.321
3505	1755	3.606	3.606
3655	1830	3.902	3.902
CASE II OR III			
3050	1830	3.252	3.252
3200	1905	3.536	3.536
3350	1980	3.832	3.832
3505	2055	4.14	4.140
3660	2135	4.459	4.459

NOTES

THE RETAINING WALL DEPICTED ON THIS DRAWING SHALL BE USED WHEN THE HEIGHT (H DIMENSION) OF THE WALL IS 3660 MM OR LESS PROVIDED THE FILL COMPLIES WITH THE FOLLOWING CONDITIONS:

- CASE I - WALL BACKFILL SLOPES DOWN, IS LEVEL, OR SLOPES UP FROM WALL AT 1:20 OR FLATTER. THIS LOW SLOPE ALLOWS FOR BACKFILLS WHICH WOULD BE LEVEL EXCEPT FOR THE SLOPE REQUIRED TO FACILITATE PROPER DRAINAGE.
- CASE II - BACKFILL SLOPES UP STEEPER THAN 1:20 BUT NOT STEEPER THAN 1:4.
- CASE III - BACKFILL SLOPES UP STEEPER THAN 1:4 BUT NOT STEEPER THAN 1:2. WHEN H DIMENSION IS GREATER THAN 2440 MM (HEIGHT OF EXPOSED FACE GREATER THAN 1830 MM INCREASE THE EMBEDMENT DEPTH TO 1/4 H. (1).

SPECIAL DESIGNS SHALL BE REQUIRED WHEN THE FOLLOWING CONDITIONS EXIST:

- (A) WALL HEIGHT IS GREATER THAN 3660 MM
- (B) WALL IS SURCHARGED WITH DEAD LOAD FILL SLOPES STEEPER THAN 1:2.
- (C) WALL IS SURCHARGED WITH A LIVE LOAD WITHIN THE LIMITS OF A 1:1 SLOPE EXTENDING FROM THE BASE OF THE WALL.

AREAS AND VOLUMES HAVE BEEN COMPUTED WITHOUT DEDUCTING FOR BEVELED EDGES OR PIPE DRAINS. WHEN A RETAINING WALL VARIES IN HEIGHT, THE PRISMOIDAL FORMULA SHALL BE USED IN COMPUTING VOLUMES.

- (1) MINIMUM EMBEDMENT VALUE FOR FIRM EARTH IS 610 MM; CASE III REQUIRES AN EMBEDMENT OF 1/4 H FOR A WALL OVER 2440 MM (SEE CASE III ABOVE).
- (2) BATTER: CASE I, AND CASE II
 H = 915 MM TO LESS THAN 1525 MM (VERTICAL)
 H = 1525 MM TO LESS THAN 3050 MM (1:2)
 H = 3050 MM TO 3660 MM (1:6)
 CASE III
 H = 915 MM TO LESS THAN 1525 MM (1:1)
 H = 1525 MM TO 3660 MM (6:1)
- (3) FABRIC WRAPPED DRAINS AND 100 MM PIPE FOR WEEPHOLES SHALL BE INCLUDED IN THE UNIT PRICE BID FOR GRAVITY TYPE RETAINING WALLS.
- 4. ALL DIMENSIONS ARE IN MILLIMETERS UNLESS SHOWN OTHERWISE.

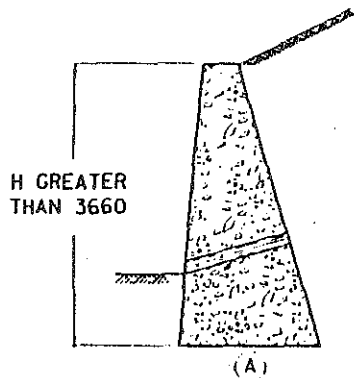

(A)

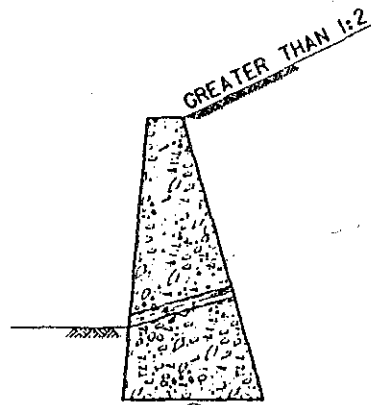

(B)

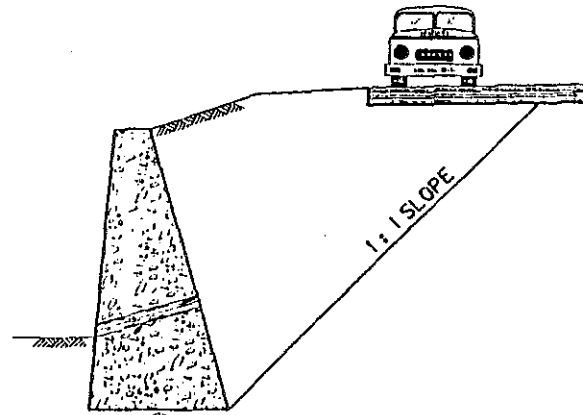

(C)

SPECIAL DESIGNS REQUIRED

KENTUCKY
DEPARTMENT OF HIGHWAYS

**RETAINING WALL
GRAVITY TYPE
NON - REINFORCED**

STANDARD DRAWING NO. RCX-002-06

PREPARED *John B. ...* 10-3-94
 CHECKED *F. J. ...* 11-3-94

GENERAL NOTES

SPECIFICATIONS: The Kentucky Department of Highways Standard Specifications for Road and Bridge Construction, current edition, with revisions.

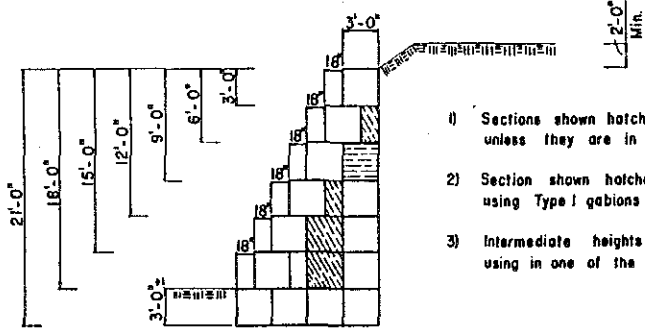

- 1) Sections shown hatched do not require gabion mesh unless they are in the bottom course of the wall.
- 2) Section shown hatched shall be counterforted by using Type I gabions alternately as headers and stretchers.
- 3) Intermediate heights of wall may be obtained by using in one of the courses 18" or 12" high gabions.

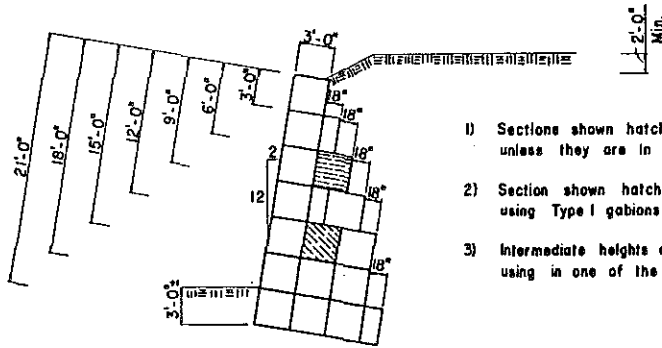

- 1) Sections shown hatched do not require gabion mesh unless they are in the bottom course of the wall.
- 2) Section shown hatched shall be counterforted by using Type I gabions alternately as headers and stretchers.
- 3) Intermediate heights of wall may be obtained by using in one of the courses 18" or 12" high gabions.

NOMINAL SIZES

TYPE	SIZE (ft.)			PARTITIONS	CAPACITY (cu. yd.)
	Length	Width	Depth		
1	6	3	3	1	2
2	9	3	3	2	3
3	12	3	3	3	4
4	6	3	1 1/2	1	1
5	9	3	1 1/2	2	1.5
6	12	3	1 1/2	3	2
7	6	3	1	1	0.66
8	9	3	1	2	1
9	12	3	1	3	1.55

* Note

Dropped From
Standard Drawing

KENTUCKY
BUREAU OF HIGHWAYS

GABION
RETAINING WALLS

FOR VARIABLE HEIGHT WALLS

STANDARD DRAWING No. 86X-008-04

SUBMITTED *Tom Lyman* 11/19/62
DIRECTOR DIVISION OF BRIDGES DATE

APPROVED *[Signature]* 11-28-64
STATE HIGHWAY ENGINEER DATE

UNITS REQD. FOR ONE PANEL

WALL HEIGHT FEET	FT. - IN.	STRINGERS				STRINGER STIFFENER
		16 GA.	14 GA.	12 GA.	10 GA.	
4.00	4'-0"	4				
5.33	5'-4"	6				
6.67	6'-8"	8				
8.00	8'-0"	10				
9.33	9'-4"	12				
10.67	10'-8"	14				
12.00	12'-0"	14	2			
13.33	13'-4"	14	4			
14.67	14'-8"	14	6			
16.00	16'-0"	14	8			
17.33	17'-4"	14	8	2		
18.67	18'-8"	14	8	4		
20.00	20'-0"	14	8	6		
21.33	21'-4"	14	8	8		
22.67	22'-8"	14	8	10		
24.00	24'-0"	14	8	12		
25.33	25'-4"	14	8	14		
26.67	26'-8"	14	8	14	2	

NOTE: This Table Includes Stringers For Both Front And Rear of a 10 FT. Panel.

* Note
Dropped From
Standard Drawing

UNITS REQUIRED FOR ONE TRANSVERSE SECTION

TYPE	WALL HEIGHT		BEARING PLATES 16x22"	FRONT COLUMN HEIGHT IN FEET			REAR COLUMN HEIGHT IN FEET			TOTAL COLUMN LENGTH IN FEET	COLUMN SPACER CAP	SPACERS GAGE AND LENGTH				BOTTOM SPACER GAGE AND LENGTH				
				FIRST LIFT	SECOND LIFT	THIRD LIFT	TOTAL HEIGHT	FIRST LIFT	SECOND LIFT			TOTAL HEIGHT	16	16	14	12	16	16	14	12
													5.2'	7.4'	9.6'	11.8'	5.2'	7.4'	9.6'	11.8'
A	4.00	4'-0"	2	4.00			4.00	1.33	1.33	5.33										
	5.33	5'-4"	2	5.33			5.33	2.67	2.67	8.00										
	6.67	6'-8"	2	6.67			6.67	4.00	4.00	10.67										
	8.00	8'-0"	2	8.00			8.00	5.33	5.33	13.33										
	9.33	9'-4"	2	9.33			9.33	6.67	6.67	16.00										
	10.67	10'-8"	2	10.67			10.67	8.00	8.00	18.67										
B	9.33	9'-4"	2	9.33			9.33	6.67	6.67	16.00										
	10.67	10'-8"	2	10.67			10.67	8.00	8.00	18.67										
	12.00	12'-0"	2	12.00			12.00	9.33	9.33	21.33										
	13.33	13'-4"	2	8.00	5.33		13.33	10.67	10.67	24.00										
	14.67	14'-8"	2	8.00	6.67		14.67	12.00	12.00	26.67										
	16.00	16'-0"	2	8.00	8.00		16.00	8.00	5.33	13.33	29.33									
	17.33	17'-4"	2	12.00	5.33		17.33	8.00	6.67	14.67	32.00									
C	14.67	14'-8"	2	8.00	6.67		14.67	12.00	12.00	26.67										
	16.00	16'-0"	2	8.00	8.00		16.00	8.00	5.33	13.33	29.33									
	17.33	17'-4"	2	12.00	5.33		17.33	8.00	6.67	14.67	32.00									
	18.67	18'-8"	2	12.00	6.67		18.67	8.00	8.00	16.00	34.67									
	20.00	20'-0"	2	12.00	8.00		20.00	12.00	5.33	17.33	37.33									
	21.33	21'-4"	2	12.00	9.33		21.33	12.00	6.67	18.67	40.00									
D	18.67	18'-8"	2	12.00	6.67		18.67	8.00	8.00	16.00	34.67									
	20.00	20'-0"	2	12.00	8.00		20.00	12.00	5.33	17.33	37.33									
	21.33	21'-4"	2	12.00	9.33		21.33	12.00	6.67	18.67	40.00									
	22.67	22'-8"	2	12.00	10.67		22.67	12.00	8.00	20.00	42.67									
	24.00	24'-0"	2	12.00	12.00		24.00	12.00	9.33	21.33	45.33									
	25.33	25'-4"	2	12.00	8.00	5.33	25.33	12.00	10.67	22.67	48.00									
	26.67	26'-8"	2	12.00	8.00	6.67	26.67	12.00	12.00	24.00	50.67									

GENERAL NOTE

SPECIFICATIONS: Kentucky Dept of Highways Standard Specifications for Road and Bridge Construction, current edition with revisions. Metal Crib Members shall be according to the Specifications.

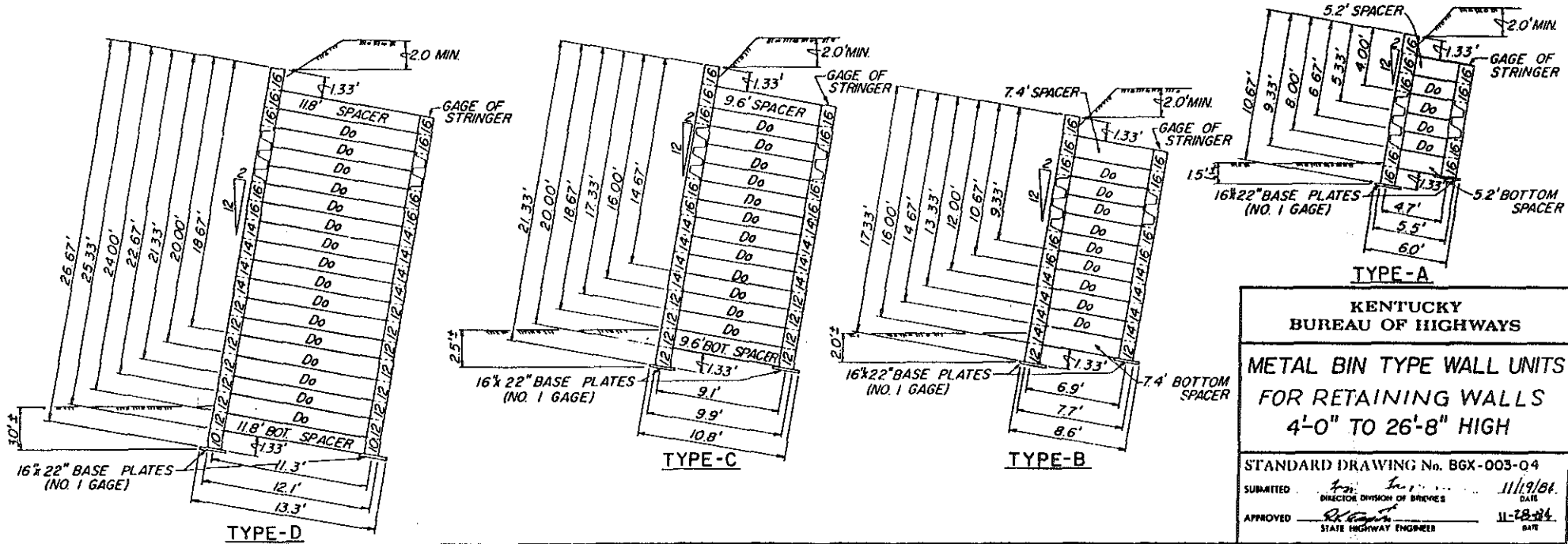

**KENTUCKY
BUREAU OF HIGHWAYS**

**METAL BIN TYPE WALL UNITS
FOR RETAINING WALLS
4'-0" TO 26'-8" HIGH**

STANDARD DRAWING No. BGX-005-04

SUBMITTED: *[Signature]* 11/19/81
DIRECTOR, DIVISION OF BRIDGES

APPROVED: *[Signature]* 11-28-81
STATE HIGHWAY ENGINEER

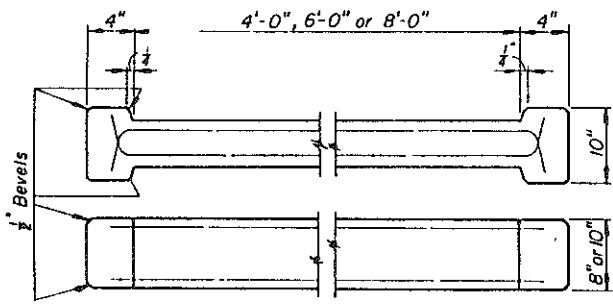

HEADER DETAILS

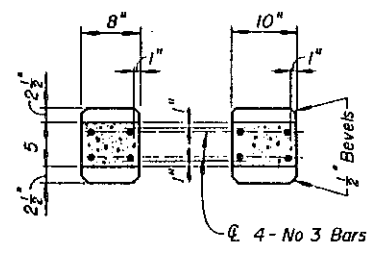

SECTION A-A

PLAN		HEADERS		STRETCHERS	
TYPE	HEIGHT OF WALL	SIZE	B LENGTH	SIZE	B LENGTH
Ft	In.	4'-0"	6'-0"	6'-0"	6'-0"
A	2	4	2		2
A	3	3	3		4
A	4	2	4		6
A	5	1	5		8
A	6	0	6		10
B	6	0		6	10
B	6	11		7	12
B	7	10		8	14
B	8	9		9	16
B	9	8		10	18
B	10	7		11	18
B	11	6		12	18
C	11	6		12	12
C	12	5		12	1
C	13	4		12	2
C	14	3		12	3
C	15	2		12	4
D	15	2	3	16	12
D	16	1	4	17	12
D	17	0	5	18	12
D	17	11	6	19	12
D	18	10	7	20	12
D	19	9	8	21	12
D	20	8	9	22	12
D	21	7	10	23	12
D	22	6	11	24	12
D	23	5	12	25	12

ELEVATION

CLOSED FACE STRETCHER DETAILS

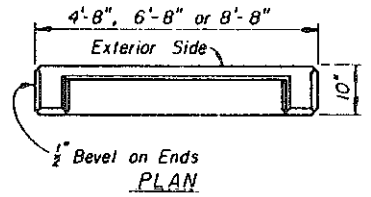

PLAN

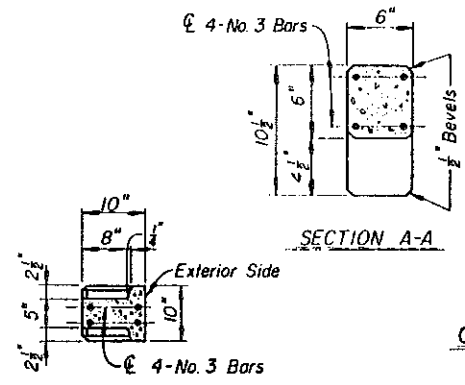

SECTION B-B

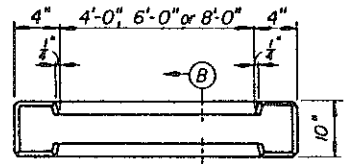

ELEVATION

CLOSED FACE END HEADER DETAILS

* Note
Dropped from
Standard Drawing

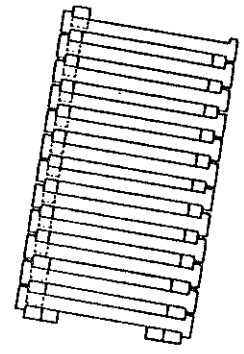

CLOSED FACE STRETCHER
END VIEW

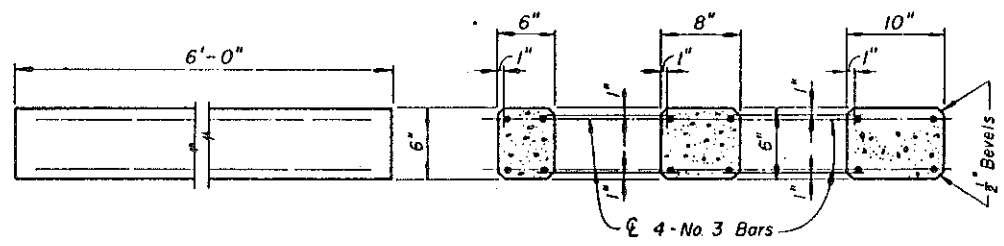

OPEN FACE STRETCHER DETAILS

NOTE:
Where 8" or 10" Stretchers are required use
Fill Block 4"x6"x10" set in Mortar to
Enlarge Bearing Area of Closed Face
Stretcher.

UNITS REQUIRED FOR ONE PANEL AND TRANSVERSE SECTION

TYPE	HEIGHT OF WALL	HEADERS				STRETCHERS		
		SIZE	B	LENGTH	SIZE	B	LENGTH	
Ft	In.	4'-0"	6'-0"	6'-0"	6'-0"	6'-0"	6'-0"	
A	2	4	2			2	3	
A	3	3	3			4	3	
A	4	2	4			6	3	
A	5	1	5			8	3	
A	6	0	6			10	3	
B	6	0		6		10	5	
B	6	11		7		12	5	
B	7	10		8		14	5	
B	8	9		9		16	5	
B	9	8		10		18	5	
B	10	7		11		18	7	
B	11	6		12		18	9	
C	11	6		12		12	15	
C	12	5		12	1	12	17	
C	13	4		12	2	12	21	
C	14	3		12	3	12	24	
C	15	2		12	4	12	27	
D	15	2	3	16		12	17	
D	16	1	4	17		12	19	
D	17	0	5	18		12	20	
D	17	11	6	19		12	20	
D	18	10	7	20		12	20	
D	19	9	8	21		12	20	
D	20	8	9	22		12	20	
D	21	7	10	23		12	20	
D	22	6	11	24		12	20	
D	23	5	12	25		12	20	

NOTE:
Work this Standard Drawing with
Standard Drawing No BGX-001-03

KENTUCKY
BUREAU OF HIGHWAYS

REINFORCED
CONCRETE
CRIBBING

STANDARD DRAWING No. BGX-002-04

SUBMITTED: *Ann* *Jan* *11/10/68*
DIRECTOR DIVISION OF HIGHWAYS DATE

APPROVED: *R. G. Smith* *11-23-68*
STATE HIGHWAY ENGINEER DATE

April 28, 1994

RETAINING WALL GENERAL NOTES
ALTERNATE WALLS

REFERENCES:

All references to the Standard Specifications are to the Kentucky Department of Highways Standard Specifications for Road and Bridge Construction, Current Edition.

All references to the AASHTO Specifications are to the Current Edition of the AASHTO Standard Specifications for Highway Bridges with Current Interims.

All references to the Special Provisions are to the Department's Current Edition.

All references to the Special Notes are to the Department's Current Edition.

ACCEPTABLE WALL TYPES:

The wall selected by the contractor shall be one of the following:

1. Mechanically Stabilized Earth (MSE) Walls;
 - a. Reinforced Earth^R,
 - b. VSL Retained Earth,
 - c. Hilfiker RSE & HSE.
 - d. GENESISTM - see Special Note,
 - e. PYRAMIDTM - see Special Note, or
 - f. ISOGRIDTM - see Special Note.
2. Cast-In-Place (C.I.P.) Reinforced Concrete Wall;
 - a. Provided by the Department or
 - b. Provided by the Contractor
3. DOUBLEWAL^R;
4. T-WALLTM - see Special Note;
5. TechWall ITM and IITM - see Special Note;
6. Evergreen (experimental); and
7. Other walls when permitted.

The wall type selected by the contractor shall be used throughout for that wall or set of walls. The walls shall conform to the requirements of Special Provision 66 and Special Notes that apply. A separate and complete set of design calculations and construction plans shall be submitted for each wall unless grouping of the walls is permitted by the Engineer. Prior approval in writing is required before walls may be submitted in groups. These notes do not apply to shoulder barrier walls.

DESIGN:

All reinforced concrete members shall be designed by the load factor design method in accordance with the AASHTO Specifications.

The wall design shall be in accordance with the AASHTO Specifications, the Special Notes, and Special Provision 66. Exceptions to these requirements are listed in these general notes or shown on the plans. Traffic live loads above the wall, if applicable, shall be considered for design as equivalent to an additional (*) feet of surcharge.

(*Use 2 feet for construction live load and 5 feet for HS 25 live load but use 2 feet for HS 25 live load on an approach slab.)

The Mechanically Stabilized Earth (MSE) Reinforcement lengths shown are the minimums required by the AASHTO Specifications and/or the minimums required to satisfy external stability. Contrary to the AASHTO Specifications, the required MSE Reinforcement lengths shall be based on the mechanical height (H') of the wall. Details shown elsewhere in these plans define the mechanical height (H'). The MSE Wall suppliers' design may require greater reinforcement lengths and MSE volume to satisfy their design. If the reinforcement lengths are increased the areas requiring foundation replacement shall be increased accordingly. The additional quantities of excavation, Roadway Fill - Granular Embankment, MSE Reinforcement and reinforced volume, and all other items necessary to complete the work required by this increased length shall be incidental to the unit price bid for the Retaining Wall. Unless otherwise shown on the plans, MSE Reinforcement lengths shall be equal to or greater than the length shown on the plans or as required by the AASHTO Specifications for the mechanical height (H') of the wall.

The lengths of the MSE Reinforcement shall be constant from the bottom to the top of the section.

The material required for the reinforced volume of MSE Walls shall extend six inches minimum beyond the ends of the reinforcement.

Contrary to the AASHTO Specifications, the carbon steel loss after zinc depletion shall be 12 um per year.

In the absence of site specific product data thje following Factors of Safety shall be used for MSE Walls with polymeric reinforcement:

FD = 2.0 and FC = 3.0

In no case shall the Factors of Safety be less than:

FD = 1.1 and FC = 1.25

Refer to the Subsurface Data Sheets for in-situ soil parameters, factors of safety for stability, and other geotechnical requirements and information. Contrary to these sheets, the coefficient of friction for sliding resistance for MSE Walls shall be no greater than tangent ϕ .

MATERIALS:

All the material used in the areas requiring foundation replacement shall meet the material requirements for Roadway Fill - Granular Embankment as given in the Current Edition of Special Provision 69, Section II. C.

ASTM or AASHTO Specifications as designated below shall govern the materials furnished:

Material	ASTM	AASHTO
Structural Steel		M-270 - Grade 50
(Add other Materials as required)		

STUB ABUTMENTS:

Foundation materials for the Stub Abutments are required to resist a maximum bearing pressure of ____* ksf. (* 4.0 Maximum)

The horizontal load on the retaining wall due to the Stub Abutment is ____ klf applied at the base of the Stub Abutment footing.

CALCULATIONS AND PLANS:

Design calculations and construction plans clearly showing conformance with the Standard Specifications, AASHTO Specifications, Special Provisions, Special Notes, and contract plans shall be submitted for approval. Wall designs and plans shall be dated, sealed, and signed by a registered professional engineer. Separate sets of plans shall be prepared and submitted for each wall required by these notes. Grouping of walls into one set of plans shall not be permitted unless prior approval from the Director, Division

of Bridges has been received or the plans state that certain walls shall or may be combined and submitted in one set of plans. The Contractor shall allow 30 working days for the Department to review his first complete submission. Additional time required by the Department to review resubmissions shall not be cause for increasing the number of contract working days and shall be at no cost to the Department.

GENERAL:

C.I.P. Walls may require expansion and contraction joints. Expansion joints shall be provided at intervals of about 90'. Contraction joints shall be provided at intervals of about 30'. Reinforcing steel shall not pass through either joint. Two inch O commercial grade smooth steel dowel bars shall be symmetrically positioned along the centerline of the joints. The spacing shall be the same as the spacing of the horizontal reinforcement. One end (18") of each dowel shall be greased to allow movement.

The method of measurement and basis of payment shall be in accordance with Special Provision 66 with modifications as shown in the contract plans. All preformed cork joint material, commercial grade caulking compound, smooth roofing paper, cut-back asphalt, commercial grade smooth steel dowels, and other materials; equipment; and labor necessary to complete the joints shall be incidental to the unit price bid per square foot face of Retaining Wall.

The upper limits, from out to out of roadway shoulders, for the reinforced backfill material used in the MSE Wall volume supporting bridge abutments shall be the top of the abutment footing or pile cap. The remainder of the embankment shall be constructed in accordance with the Specifications. Type IV geotextile fabric shall be used as a separator between the MSE Reinforced backfill material and the embankment materials. The contractor shall have the option of constructing this portion of the embankment with the same material as used in the reinforced backfill and eliminating the geotextile fabric.

The bottom of wall elevation may be raised if solid rock is encountered. However, the top of the leveling pad or footing shall be a minimum of six inches below the finish grade in front of the wall or as directed by the Engineer. The Retaining Wall pay limits shall be revised accordingly.

Foundation replacement of the in-situ soil with Roadway fill - Granular Embankment is required at certain sections of the walls. The upper limit is the bottom of wall elevations as shown on the plans. The lower limit and the lateral limits for foundation replacement are shown on the plans. At some sections the lower limit for foundation replacement is shown as solid rock. An interpolated rock line has been used to define the lower limit. The interpolated rock line has been used for calculating external stability, allowable bearing capacity, and pay quantities. All work associated with foundation replacement shall be incidental to the unit price bid for Roadway Fill - Granular Embankment. The pay limits for Roadway Fill - Granular Embankment shall be identical to the limits for foundation replacement.

Changing the limits or quantities of the retaining wall or foundation replacement, except as directed by the Engineer shall not be cause for changing the plan pay quantities. Lowering the bottom of wall elevations to accommodate the wall design or configuration of pre-fabricated concrete units shall not be cause for changing the plan pay quantities. Extension of the horizontal limits to accommodate the wall design, configuration of pre-fabricated concrete units, or lengths of soil reinforcement for MSE Walls shall not be cause for changing the plan pay quantities.

Excavation, sheeting, shoring, labor, and equipment necessary to complete this work shall be incidental to the unit price bid for Roadway Fill - Granular Embankment. The pay quantity for Roadway Fill - Granular Embankment shall be adjusted for the rock line as determined in the field.

Any roadway Fill - Granular Embankment used to backfill over-excavation, at wall steps, or behind the wall volume shall be incidental to the unit price bid for the Retaining Wall.

Refer to the Suosurface Data Sheets for geotechnical design parameters and requirements. In no case shall the geotechnical strength parameters used for design exceed the values allowed by the AASHTO Specifications.

All final wall tracings, with drqwing number, shall be submitted on 3 mil, or thicker, 22" X 36" mylar film. The format shall be in accordance with the Division of Bridges Guidance Manual. The first sheet shall be a title sheet. The preparer of the wall designs and plans shall contact the Division of Bridges before beginning any work. The drqwing number is 23174.

OPTIONAL NOTES

Contrary to Special Provision 66, a design and construction plans can be provided by the Department (or Consultant) for a C.I.P. Wall (or other type). The Contractor shall notify the Department within 30 calendar days of receipt of the Notice to Proceed if design and construction plans are required. The Contractor shall allow the Department (or Consultant) 30 working days to provide the design(s) and construction plans. The Contractor shall have the option of providing his own wall design(s) and construction plans in accordance with Special Provision 66.

Sheeting, shoring, temporary walls or other earth retention systems necessary to stabilize the earth behind the wall(s) during construction shall be the responsibility of the Contractor. All designs, labor, materials, etc. required to complete this work shall be at no additional cost to the Department, but shall be incidental to the unit price bid for the Retaining Wall(s).

See the Lighting Plans for details of light standards, conduits, etc.

GENERAL INSTRUCTIONS

If the date of the Current Edition of AASHTO or the Standard Specifications is not shown elsewhere in the plans, show the date in these General Notes.

If the Current Edition of Special Provisions or Special Notes are not shown elsewhere in the plans, show the correct edition under References. Place References on the right side and above the title block of sheet one of the plans.

The Geotechnical Branch will provide the list of acceptable wall types. Show only the walls selected as Acceptable Wall Types.

As of April 20, 1994, the following walls have not been approved and the Special Notes have not been approved:

1. ISOGRID™,
2. PYRAMID™,

Provide live load surcharge.

Has the maximum bearing pressure and horizontal load for stub abutments been provided?

Is an estimate of quantities for Department/Consultant designed C.I.P. Wall provided?

Add slash to phi angle symbol.

Is mechanical height (H') shown in the plans?

Have the proprietary wall suppliers been notified?

Are the addresses of the proprietary wall suppliers shown?

ADDITIONAL NOTES
C.I.P. WALL

GENERAL NOTES

Design Loads: The retaining walls are designed in accordance with the current AASHTO Specifications. The effective weight of the soil is * pounds per cubic foot. The equivalent fluid pressure of the soil is * pounds per cubic foot. Traffic live loads above the wall, if applicable shall be considered for design as equivalent to an additional ** feet of earth surcharge.

* See Geotechnical Engineering Report

** Use 2 feet for construction live load and 5 feet for HS 25 live load but use 2 feet for HS 25 live load on an approach slab.

Design Method: All reinforced concrete members are designed by the load factor method as specified in the current AASHTO Specifications.

Sawcutting Existing Concrete: Prior to the removal of existing concrete masonry, cut the surface with a concrete saw to a depth of one inch to facilitate a neat line. The cost of all materials, labor, and incidental items necessary to complete this work shall be incidental to and included in the unit price bid for Class A Concrete.

Bonding New Concrete to Old Concrete: All new concrete shall be bonded to the old concrete with a Two-Component Epoxy Resin System conforming to sections 736 and 833 of the Specifications. The cost of all materials, labor, and incidental items necessary to complete this work shall be incidental to and included in the unit price bid for Class A Concrete.

PLAN NOTES

1. The costs of all materials, labor, and incidental items necessary to complete the Rustication Pattern and Masonry Coating Finish shall be incidental to and included in the unit price bid for Class A Concrete.
2. The costs of all materials, labor, and incidental items necessary to install the 1" Premolded Expansion Material and Joint Waterproofing shall be incidental to and included in the unit price bid for a Class A Concrete.
3. Reinforcing steel shall not pass through expansion joints or construction/contraction joints. Commercial grade smooth steel dowel bars shall be placed along the centerline of the joint. The Dowel bars shall have a one inch diameter and be thirty-six inches. One end of the dowel bars. shall be greased.

In the absence of site specific product data the following Factors of Safety shall be used for MSE Walls with polymeric reinforcement:
FD = 2.0 and FC = 3.0

In no case shall the Factors of Safety be less than:
FD = 1.1 and FC = 1.25

Expansion joints are to be provided at intervals of about 90'. Contraction joints are to be provided at intervals of about 30'. Reinforcing steel shall not pass through either joint. Two inch \emptyset commercial grade smooth steel dowel bars shall be symmetrically positioned along the centerline of the joints. The spacing shall be the same as the spacing of the horizontal reinforcement. One end of each dowel shall be greased to allow movement.

All preformed cork joint material, commercial grade caulking compound, smooth roofing paper, cut-back asphalt, commercial grade smooth steel dowels, and other materials, equipment and labor necessary to complete the joints shall be incidental to the unit price bid per square foot of Retaining Wall.

1991 INTERIM

C5.2.1.4

Full height panels (30 square feet) when used, have been subject to longitudinal and vertical cracking and visible bending.

Where ground stray currents are anticipated within a 200-foot distance of a structure, the potential for stray current corrosion exists, when metallic reinforcements are used. Induced-current cathodic protection measures have not been successful in the past and have caused two known failures.

C5.8.1

Parametric studies considering minimum acceptable soil strengths have shown that structure dimensions satisfying all requirements of Article 5.8.1 require length to height ratios varying from $0.8H$ for low structures (10 feet) to $0.63H$ for high structures (40 feet).

Shorter reinforcing lengths may be considered for structures in cut situations or constructed on rock. Under these conditions, bottom reinforcements have been shortened to 40 percent of the structure height in lieu of removing rock for construction.

C7.5.4

The minimum length of reinforcement based on experience has been taken as 22 feet or equal to $0.6H + 6.5$ feet, which ever is greater. (H measured from bottom of wall to roadway surface) Length of reinforcement should be constant throughout the height to limit differential settlements across the reinforced zone which overstresses the reinforcements.

At abutments the relative high footing loads near the panel connections increase the connection load to calculated maximum values and therefore no reduction should be applied.

7.5.4

Abutment footings shall be proportioned to meet the overturning and sliding criteria specified in Article 5.5.5 and for maximum uniform bearing pressure using an effective footing width of foundation ($B - 2e$). The maximum allowable bearing pressure shall be 4.0 ksf.

INSTRUCTIONS
FOR
MSE WALLS

PREBID

1. Determine Mechanical Height - H'.
 - a. All Abutments, H' = Height of wall from bottom of wall to roadway surface.
 - b. Wall, Level Backfill, H' = Height of wall from bottom to wall to top of backfill.
 - c. Wall, Sloping Backfill, H' = H (level Backfill) divided by [1-0.3tanB]
Where B = slope of backfill.
 $H' = H/[1 - 0.3\tan B]$

2. Estimate bearing pressure (p) in ksf.
 - a. True Abutments, $p \geq 1.54 H' + 1.44$
 - b. Walls with Pile Bents, $p \geq .176 H'$
 - c. Traditional Walls, $p \geq .176 H'$
(H in feet)

3. Estimate Strap Length in feet. The minimum reinforcement length shall be the greater of the following.
 - a. True Abutments, $L = 22.0'$
 $L = 0.6 H + 6.0'$
 - b. Pile Bents, $L = 0.7 H$
 $L = 8.0'$
 - c. Traditional Walls, $L = 0.7 H$
 $L = 8.0'$
(H in feet)

4. Calculate Allowable Bearing Capacity with no undercut.
 - a. Cohesive Soil, $abc = (5.53c/2 + yd)$
Example $c = 1.000$ ksf, $y = 0.125$ kcf, and $d = 2'$.
 $abc = 3.02$ ksf
 - b. Cohesionless Soil, $abc = (ydNq + 0.4 yBNy)/2$
Example $y = 0.125$ kcf, $Nq = 33$, $Ny = 14.5$,
 $d = 2'$, and B(feet) = Straplength
L(feet).
 $abc = (4.588 + .348 B)$ ksf

Refer to Geotechnical Engineering Report for soil parameters.

5. Estimate Depth of Undercut (d) and replacement with Roadway Fill - Granular embankment if Required, ie. $p > abc$ (at base of wall).

p ~ See Step 2
 $L' = p(L)/abc$ (at base of undercut)
 $L' = L + d$
 $d = L' - L$

6. Calculate Nominal Allowable Bearing Capacity due to Undercut.

$$\text{Nominal } abc' = (abc) L/L'$$

The Nominal Allowable Bearing Capacity is that pressure allowed at the base of the wall which will not exceed the Allowable Bearing Capacity at the base of the undercut.

POST BID

Note: Copies of the design calculations and construction plans are forwarded to the Geotechnical Branch. Design consultant are provided with copies if they are involved.

1. Check vertical and lateral limits.
Check limits of undercut if applicable.
Review plan notes and details.
- 2.. Check applied pressure (p).
p <= abc - no undercut
p <= abc' - with undercut
3. Review design calculations.
4. Return red-marked copy of calculations and plans for revision if necessary.
Request calculations and plans be resubmitted for review if necessary.
5. After calculations and plans are satisfactory, request mylar reproducible.
6. Forward nine full-size and two reduced-size copies to the division of construction. Forward one reduced-size copies of the plans to the Geotechnical Branch and, if applicable, to the consultant.

* * * Note $\gamma =$ (unit weight)

* * * Roadway Fill - Granular Embankment for undercut backfill shall be meet the requirements of Special Provision 69, Current Edition.



COMMONWEALTH OF KENTUCKY
TRANSPORTATION CABINET
FRANKFORT, KENTUCKY 40622

DON C. KELLY, P.E.
SECRETARY OF TRANSPORTATION

BRERETON C. JONES
GOVERNOR

JERRY D. ANGLIN
DEPUTY SECRETARY
AND
COMMISSIONER OF HIGHWAYS

February 16, 1994

Mr. Ray Greer, P.E.
Federal Highway Administration
John C. Watts Building
Frankfort, KY 40601

Gentlemen:

In Re: State Approved Retaining Walls

The following wall systems are acceptable for routine use.

- A. Mechanically Stabilized Earth (MSE) Walls
 - 1. By Special Provision 66
 - a. Reinforced Earth Wall,
 - b. VSL Retained Earth Wall, and
 - c. Hilfiker RSE Wall.
 - 2. By Special Note
 - a. Genesis Wall,
 - b. Pyramid Wall, and
 - c. ISOGRID Wall.
(Special Notes for walls 2.b. and 2.c. are in final development stage.)
- B. Cast-In-Place (C.I.P.) Reinforced Concrete Walls
 - 1. Design provided by the Department and
 - 2. Design provided by Contractor.
- C. Doublewal - by Special Provision 66
- D. T-Wall - by Special Note
- E. TechWall I & II - by Special Note
- F. Evergreen Wall - by Special Provision 66 (Experimental)

Walls are 'approved' for use on a site specific basis. Currently only C.I.P. walls and the MSE Walls of Item A.1. are permitted for the support bridge abutments.

We have no stated cutoff for height of wall. I have no knowledge of a Department constructed wall exceeding 30 feet. Walls exceeding 25 feet, having unusual foundation conditions, or requiring unique design would be reviewed in-depth by this Division and the Geotechnical Branch. The Department would then list in the plans the walls approved for the particular situation.

Preliminary plans are required for all situations where a wall is required. Plans are either developed for a specific wall system or for alternate walls.

Mr. Ray Greer, P.E.
Page #2
February 16, 1994

When the contract documents permit alternate walls, the contractor is required to choose a system from the list of walls approved for each situation. The list of approved walls is shown on the plans for each wall site.

Contact this office if you have questions.

Yours very truly,

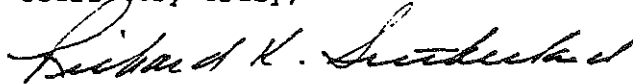

Richard K. Sutherland, P.E.
Director
Division of Bridges

RKS/WHP/rrm



COMMONWEALTH OF KENTUCKY
TRANSPORTATION CABINET
FRANKFORT, KENTUCKY 40622

DON C. KELLY, P.E.
SECRETARY OF TRANSPORTATION

BRERETON C. JONES
GOVERNOR

JERRY D. ANGLIN
DEPUTY SECRETARY
AND
COMMISSIONER OF HIGHWAYS

May 20, 1993

Mr. Paul Toussaint
Division Administrator
Federal Highway Administration
Frankfort, Ky. 40602

ATTN: Gary Kinchen

Gentlemen:

In Re: Retaining Wall Systems

This letter provides the Department's current policy for accepting new Retaining Wall Systems. The Department treats new wall systems as a new product. This review effort is currently coordinated by the New Product Evaluation Committee located in the office of the State Highway Engineer. Willie McCann is the chairman of this committee.

When the manufacturer or supplier of a proprietary product contacts anyone in the Department concerning his system he is referred to Willie McCann. The manufacturer is required to complete form TC 40-12, "Preliminary Information for Product Review". A copy of this form is enclosed. His submission of this form to the New Product evaluation committee initiates the Department's review process for his product.

A "New Product Evaluation Report" is prepared by Willie McCann. A sample of this report is enclosed. The Divisions expected to review the product are shown on the form with the routing sequence by number.

Mr. Paul Toussaint
May 20, 1993
Page #2

The Division of Bridges and the Geotechnical Branch are mainly responsible for recommending the acceptance or rejection of new wall systems. The Divisions of Construction, Design, and Maintenance usually provide only an cursory review.

Completion of this review constitutes the first step in preliminary approval of the wall system. The Report is presented to the New Product Evaluation Committee By Willie McCann. The committee forwards the report to the State Highway Engineer with recommendation to approve or reject the product. Most wall systems are given a conditional approval. They are used on projects where permitted by the contract documents.

The State Highway Engineer has the authority to reject products that have been recommended for acceptance by the committee. Products approved by the State Highway Engineer still must receive acceptance by the FHWA Division office before they can be used on federal aid projects.

The next step is a request for the manufacturer to provide more detailed information for an in-depth review. Documentation of design theory, design calculations, construction plans, construction manuals, material specifications, and special notes are required. The Division of Bridges and the Geotechnical Branch perform an in-depth review of all the information. We work closely with manufacturer during this review. If necessary, we request that a representative of the manufacture meets with us to explain his system.

Currently we require all Mechanically Stabilized Earth Systems to be designed for a 100 year life. Contrary to AASHTO, we use a 'steel loss after zinc depletion' of 12 um per year. The Department's gradation requirements for material within the stabilized earth volume are found in Special Provision 66.

The Department uses the following references for review of new wall systems.

1. 1991 AASHTO,
2. Task Force 27 'In-Situ Soil Improvement Techniques', (Henry Phillips was a member of this FHWA Task Force.),
3. FHWA Foundation Engineer Manual,
4. FHWA Tieback Manuals.
5. Roadway Plans,
6. Division of Bridges and Geotechnical Guidance Manuals,
7. Special Provisions and Special Notes, and
8. Proprietary Design and Construction Manuals.

Mr. Paul Toussaint
May 20, 1993
Page #3

Acceptance of a manufacturer's proprietary wall does not constitute blanket approval for use of that wall indiscriminately on any project. Site specific requirements and Department restrictions limit acceptable wall types. The contract plans list the acceptable wall types for the project. The Division of Bridges and the Geotechnical Branch have the main responsibility for deciding which wall types are acceptable. The Division of Design and the District Design Office may recommend or reject certain wall types. Usually their determination is for aesthetic reasons or to match an existing wall.

Site specific limitations may also preclude certain wall types at various locations. For instance, Reinforced Earth and VSL Retained Earth walls are the only Mechanically Stabilized Earth Walls permitted for supporting bridge abutments. Height of wall may limit the use of standard gravity walls, cantilevered walls, crib walls, metal bin walls and gabion walls.

The Division of Construction and District Construction personnel are responsible for the construction supervision of all walls. Redesigns or plan revisions due to construction conditions, plan errors, utility conflicts or other field conditions are handled by the Division of Bridges. The Division of Bridges requires the manufacturer of proprietary wall to revise the design or plans when their wall is involved.

The contractor is responsible for providing the design calculations and construction plans for the wall system he chooses unless a set of construction plans were included in the contract plans. The Division of Bridges and Geotechnical Branch review the contractor's submissions in-depth. The design, details, dimensions, and elevations are not completely checked. The contractor is responsible for the completeness of his wall plans and for their conformance with the contract. The Department's review does not relieve the contractor from full responsibility for the accuracy and completeness of his design calculations and construction plans.

Information concerning the Department's contracting procedures for alternate wall systems is discussed in our April 26, 1993, letter to your office.

Mr. Paul Toussaint
May 20, 1993
Page #4

Notify this office if additional information is required.

Yours very truly,

J. M. Yowell, P.E.
State Highway Engineer



BY: R. K. Sutherland, P.E.
Director
Division of Bridges

RKS/WHP/rrm
Enclosures

cc: J. M. Yowell
Charlie Raymer
Willie McCann
FHWA Files



COMMONWEALTH OF KENTUCKY
TRANSPORTATION CABINET
FRANKFORT, KENTUCKY 40622

DON C. KELLY, P.E.
SECRETARY OF TRANSPORTATION

BRERETON C. JONES
GOVERNOR

JERRY D. ANGLIN
DEPUTY SECRETARY
AND
COMMISSIONER OF HIGHWAYS

April 26, 1993

Mr. Paul Toussaint
Division Administrator
Federal Highway Administration
P.O. Box 536
Frankfort, Kentucky 40602

ATTN: Gary Kinchen & Ray Greer

Gentlemen:

In Re: Alternate Retaining Walls

This letter provides the Department's current (unofficial) policy for contracting for Alternate Retaining Walls. This effort is currently coordinated by Henry Phillips in the Division of Bridges.

References to the 'design engineer' can mean either the Department's or the consultant's roadway or structure engineer. Currently, the structure engineer takes the lead in assuring that alternate wall plans are prepared and included in the contract plans.

Mr. Paul Toussaint
April 26, 1993
Page #2

PREBID

Step 1: The engineer preparing the roadway plans is responsible for identifying the locations requiring retaining walls.

Step 2: By consensus, engineers from the roadway, structures, and geotechnical disciplines review the situations and recommend appropriate retaining wall alternates for each specific wall location.

Step 3: A subsurface exploration plan is developed and implemented for each wall situation. The proposed investigation and testing plan should be reviewed by the structure engineer. Geotechnical engineers provide a report with recommendations for the various acceptable wall types. The report provides the geotechnical design parameters and the requirements for external stability, overturning, sliding, and bearing. This report also addresses any special requirements such as granular backfill behind the wall and undercutting with granular replacement beneath the wall. This report should be comprehensive enough for the structure engineer to analyze different wall types for feasibility and economics.

Step 4: The roadway engineer provides the physical limits for each wall. He should provide the top of wall elevation, finish grade elevations, lateral limits, stationing and offsets to face of wall, right-of-way, utilities restrictions, special architectural treatment of facing, etc.

Step 5: The structure engineer is responsible for providing the final contract documents and construction plans. Generally, plans for walls involving roadway cuts and/or fills only are included in the roadway plans. Walls involving structures are included in the plans for that particular structure. In some cases a separate set of structure plans are provided for a wall. It is the structure engineer's responsibility to determine how plans are treated for each specific wall. Currently, it is the structure engineer's responsibility to insure that there are no conflicts among the Subsurface Data Sheets, Roadway Plans, Structure Plans Special Provisions, Special Notes, Specifications, and any other contract document.

Mr. Paul Toussaint
April 26, 1993
Page #3

The structure engineer is responsible for consolidating the information provided by the roadway and geotechnical engineers and accuracy of the final details and notes for the contract plans. The structure engineer is responsible for ensuring that the depth of burial, wall height, and lateral limits meet design, specification, and project requirements. The structure engineer is responsible for developing and enforcing the design criteria for proprietary walls. The structure engineer provides the minimum soil reinforcing lengths for Mechanically Stabilized Earth (MSE) Walls. The geotechnical engineer determines when granular material is needed behind or beneath the wall. The structure engineer provides the physical limits for the final design and details for the undercut and granular replacement when needed. The structure engineer relies extensively on the Geotechnical Engineering Report for developing many of these restrictions. Method of Measurement and Basis of Payment is developed by the structure engineer.

Note: At any time prior to the letting, the permitted wall types may be amended by geotechnical, roadway or structure engineers.

POST BID

Step 6: When a set of wall plans is not part of the contract documents, the contractor is required to submit a set of design calculations and construction plans for one of the permitted wall types for the particular location. The Division of Bridges is responsible for coordinating the review of all design calculations, construction plans, and shop drawings submitted by the contractor. Review comments are solicited from roadway and geotechnical engineers. The structure engineer consolidates all comments and forwards a marked-up copy of the design calculations and construction plans to the contractor for revision. The design, details, dimensions, and elevations are not necessarily completely checked. The contractor is responsible for the design and for the completeness of the wall plans. The review does not relieve the contractor of full responsibility for the accuracy and completeness of his design calculations and construction plans and for conformance with the contract documents.

Mr. Paul Toussaint
April 26, 1993
Page #4

Step 7: When the design calculations and construction plans have been completed to the satisfaction of the Department, the contractor is requested to submit final design calculations and mylar reproducible copies of the construction plans to the Division of Bridges. The Division of Bridges provides sufficient full-size and reduced-size copies of the construction plans to the Division of Construction for distribution.

Note: Steps 6 and 7 are skipped if the contractor uses a set of wall plans which were included in the contract documents.

Step 8: Conflicts, changes, revisions and/or corrections due to field conditions or project requirements are resolved by the structure engineer.

GENERAL

The 'Basis of Payment' is square foot face as measured in a vertical plane. The 'Pay Limits' are shown on the contract plans. Changes in the pay limits to accommodate a particular design or the configuration of proprietary precast wall panels are not permitted. Necessary changes in the pay limits require prior written approval from the Department.

The Division of Bridges is responsible for maintaining the permanent files for all walls. The design files include a copy of the Geotechnical Engineering Report and all pre-bid correspondence. The construction files have all the post-bid correspondence. All design calculations are kept in a separate calculation file. Final plans are kept in the Division of Bridges plan files.

Currently the Division of Bridges uses the following references for wall design and construction:

1. 1991 AASHTO,
2. Task Force 27 'In-Situ Soil Improvement Techniques', (Henry Phillips was a member of this FHWA Task Force),
3. FHWA Foundation Engineer Manual,
4. FHWA Tieback Manuals,

Mr. Paul Toussaint
April 26, 1993
Page #5

5. Roadway Plans,
6. Division of Bridges and Geotechnical Guidance Manuals,
7. Geotechnical Engineering Report,
8. Special Provisions and Special Notes, and
9. Proprietary Design and Construction Manuals.

Alternate Wall Types:

1. Mechanically Stabilized Earth Walls
 - A. With inextensible reinforcement
 - B. With extensible reinforcement
2. Modular Walls
3. Precast Walls
4. Crib Walls
5. Tieback Walls
 - A. With a pressure treated timber face
 - B. With a reinforced concrete face
 - a. Cast-in-place
 - b. Precast
6. Tangent Pile Walls
7. Cast-in-place Reinforced Concrete Walls
8. Standard Walls
 - A. Concrete gravity wall
 - B. Metal Bin wall
 - C. Concrete crib wall
 - D. Gabion wire wall
9. A myriad of Proprietary Walls
(Note: There are too many brand names to try to list the different walls by trade names.)

The following are enclosed:

1. Instructions for MSE Walls,
2. Sample set of Retaining Wall General Notes, and
3. Sample set of pre-bid plans.

The Division of Bridges is also responsible for the Department's noise wall effort. Currently, the contractor is responsible for providing design calculations and construction plans for noise walls. The contracting process is similar to that used for alternate retaining walls. The Department provides all physical and design requirements. The AASHTO Guide Specifications for Structural Design of Sound Barriers, Current Edition, is used as well as many of the references used for alternate retaining walls.

Mr. Paul Toussaint
April 26, 1993
Page #6

The Department currently permits steel, concrete (Cast-in-place or precast), and masonry noise walls.

NEEDS

1. Standard Drawings for Cast-in-Place Cantilevered Reinforced Concrete Retaining Walls with and without Traffic Barriers.
2. Office Practice for Alternate Retaining Walls.
3. Microstation capability.
4. Computer program for analyzing MSE Walls.
5. Capability for checking internal stability of MSE Walls.

Yours very truly,

J. M. Yowell, P.E.
State Highway Engineer

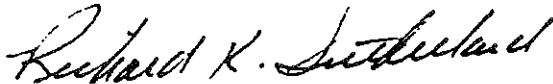

BY: Richard K. Sutherland, P.E.
Director
Division of Bridges

RKS/WHP/rrm
Enclosures
cc: J. M. Yowell
Charles Raymer-w/a
FHWA Files-w/a

**KENTUCKY TRANSPORTATION CABINET
DEPARTMENT OF HIGHWAYS
SPECIAL PROVISION NO. 49 (94)
METAL SOUND BARRIER**

This Special Provision shall apply when indicated on the plans or in the proposal.

I. DESCRIPTION

This work shall consist of furnishing and installing a metal sound barrier in accordance with the requirements of this Special Provision, the 1991 Standard Specifications, the plans, and proposal.

II. MATERIALS

A. General. When tested in accordance with ASTM E 90, the sound barrier wall shall provide a minimum transmission loss of 16 dB at 500 Hz and 20 dB at 2,000 Hz.

B. Interlocking Panels. Panels shall be interlocking, shall be of steel meeting the requirements of ASTM A 446, Grade B, and shall be galvanized in accordance with ASTM A 525, Class G 90. The panels shall have a minimum thickness of 22 gage, unless otherwise specified.

C. Flashings and Caps. All corner flashings and other flashings, and caps, shall be fabricated from the same steel material, and be the same thickness, as the panels. All posts and girts shall be covered by flashing. Galvanizing of flashings and caps shall meet ASTM A 525, Class G 90.

D. Protective Color Coating. All panels, post covers, cap trim, corner flashings, and other flashings shall have a polyvinyl fluoride coating at least 38 μm (1 1/2 mils) thick. The coating shall be a product recommended for this use by the coating manufacturer. The coating shall be capable of withstanding removal of stains by use of detergents, paint solvents, or commercially available cleaning fluids, with no color change or damage to the coating. Color shall be as specified elsewhere in the contract.

The galvanized steel shall be cleaned, and the coating applied, at the factory in strict accordance with the recommendations of the coating

manufacturer. Ends of panels cut after the coating is applied shall be touched-up with color matching paint either furnished or recommended by the coating manufacturer.

Color-matching enamel for touch-up of minor scratches in the coating after erection shall be a product either furnished or recommended by the coating manufacturer.

The panels shall be embossed after application of the protective color coating, in a manner that will minimize light reflectance under wet conditions.

E. Posts and Girts. Posts and girts shall be fabricated from steel meeting the requirements of ASTM A 36, and shall be galvanized in accordance with ASTM A 123.

F. Fasteners. All bolts, nuts, washers, self-drilling screws, and other fasteners that will be exposed in the finished work shall be stainless steel meeting the requirements of ASTM A 320. Fasteners covered by flashing shall conform to ASTM A 307 and be galvanized in accordance with ASTM A 164.

G. Shop Drawings. The Contractor shall submit shop drawings for review by the Engineer, showing top and bottom elevations of the panels, finished grade line and theoretical sound attenuation line. Any fabrication begun on the sound barrier before the Engineer's review of the shop drawings is completed will be at the Contractor's risk.

The Contractor is responsible for determining the actual ground elevations at the location of the barrier, and the post length and panel height necessary.

H. Material Certification & Test Reports. Each shipment of material to the project shall be accompanied by 4 copies of the following items:

(1) a certification from the barrier manufacturer that all manufactured materials meet the requirements of this Special Provision;

(2) test reports from an independent laboratory showing that the barrier meets the sound transmission loss requirements in paragraph II.A above;

(3) certification from the protective coating manufacturer that the resin portion of the protective coating is 100 percent polyvinyl fluoride; and

(4) descriptive and technical literature from the coating manufacturer giving recommended cleaning materials and procedures.

Construction of the barrier shall not begin until the certifications and test reports have been approved by the Engineer. All material is subject to inspection and testing after delivery to the project.

I. Concrete. Concrete for setting posts shall be Class A, meeting the requirements of Section 601 of the Department's Standard Specifications.

J. Design Load. Unless otherwise specified, the barrier shall be designed to withstand a wind load of 2.2 kPa (45 psi).

III. CONSTRUCTION REQUIREMENTS

A. General. The metal sound barrier shall be installed in accordance with the plans, and the manufacturer's recommendations. Bolts and other fasteners shall be installed and tightened so the barrier is structurally sound, and to prevent secondary noise transmission due to vibration. All flashings and caps shall be installed to obtain a structure that is weathertight. The face of the completed barrier shall not deviate from the vertical more than 4 mm in one meter (1/2 inch in 10 feet). Horizontal alignment shall be uniform, with no significant irregularities.

Minor surface scratches in the protective coating shall be repaired with color-matching paint, in accordance with the coating manufacturer's instructions. Major damage to the coating or failure of repairs to match the coating color will be cause for rejection of the damaged piece, which shall be replaced with acceptable material at no cost to the Department.

B. Foundation Design. If solid rock is encountered above the bottom-of-post elevations required by the plans, the Contractor may submit an alternate post foundation design for review by the Engineer. Before preparing

an alternate foundation design, the Contractor should contact the Engineer to obtain the design criteria that must be met. The proposed design shall include all calculations. If the Engineer determines that the proposed design is not acceptable, then the post foundations shall be constructed in accordance with the plans.

No extension of contract time for delay during review of the proposed design will be considered. No increase will be made in the contract unit price for the metal sound barrier as a result of permitting a change in the post foundations.

IV. METHOD OF MEASUREMENT

The metal sound barrier will be measured in square meters (square feet) of exposed front wall surface (facing the roadway) complete in place, calculated by multiplying the length of each section by the design height shown on the plans. The design height of each section will be the average vertical dimension from the theoretical sound attenuation line to the finished grade line shown on the plans. This height will be the minimum height required to achieve the desired sound attenuation, as determined from analysis of site characteristics.

The actual height of barrier sections used will depend on the post spacing and panel arrangement employed.

The final pay quantity will be the design quantity. No additional payment will be allowed if the barrier sections used exceed the design height.

V. BASIS OF PAYMENT

The quantity of acceptably completed metal sound barrier, measured as above, will be paid for at the contract unit price per square meter (square foot). Such payment shall be full compensation for all labor, materials, equipment and incidentals necessary to furnish and install the barrier, including excavation, concrete, and backfill necessary to install the posts and wall, clearing and grubbing or trimming vegetation that would interfere with erection of the barrier, restoration to the original grade of any portion of the existing roadway or shoulder damaged by construction of the sound barrier, and disposal of surplus materials from post foundation excavations.

**KENTUCKY TRANSPORTATION CABINET
DEPARTMENT OF HIGHWAYS
SPECIAL PROVISION NO. 59 (94)
WOOD SOUND BARRIER**

This Special Provision shall apply when indicated on the plans or in the proposal.

I. DESCRIPTION

This work shall consist of furnishing and installing a wood sound barrier in accordance with the requirements of this Special Provision, the 1994 Standard Specifications, the plans, and proposal.

II. MATERIALS

A. General. All materials shall comply with the dimensions on the plans and/or approved shop drawings, and the various individual materials requirements of this special provision. Surface finish of wood products shall be as required by the plans.

B. Concrete. Concrete for setting posts shall be Class A, meeting the requirements of Section 601 of the Department's Standard Specifications.

C. Posts.

(1) Round Posts. Round posts shall meet the requirements of ANSI Specification 05.1 for wood poles. Species may be any species that is covered by both ANSI 05.1 and AWPA C 4. Wood poles shall be of the class specified on the plans.

(2) Saved Timber Posts. Sawed posts shall be surfaced on 4 sides (S4S), and may be Southern Pine (any species) or Douglas Fir. Grade or stress rating shall be as shown on the plans.

(3) Laminated Wood Posts. Laminated wood posts may be Southern Pine (any species) or Douglas Fir, and shall be structural glued laminated wood for exterior "wet use" conditions as covered by Voluntary Product Standard PS 56-73. Stress rating shall be as shown on the plans.

(4) Structural Steel Posts. Steel posts shall be fabricated from steel meeting the requirements of ASTM A 36, and shall be galvanized in accordance with ASTM A 123.

D. Planks. Planks shall be No. 2 structural or better Southern Pine (any species) or Douglas Fir. Minimum nominal thickness shall be 51 mm (2 inches). Planks used as sound-reflecting surfaces shall be tongue-and-groove, to eliminate sound leaks. The minimum depth of the tongue shall be 19 mm (3/4 inch); typical details of the tongue-and-groove joint shall be shown on the Contractor's shop drawings.

E. Plywood. Plywood shall be exterior type. Grade and finish shall be as specified on the plans. Plywood for single-piece construction shall be at least 19 mm (3/4 inch) thick. Plywood used in double-wall construction shall be at least 15.9 mm (5/8 inch) thick.

F. Panel Framing Lumber. Framing lumber shall be No. 2 structural or better Southern Pine (any species) or Douglas Fir, and shall be S4S.

G. Laminated Panels. Laminated panels may be Southern Pine (any species) or Douglas Fir, and shall be structural glued laminated wood for exterior "wet use" conditions as covered by Voluntary Product Standard PS 56-73. Stress rating shall be as shown on the plans.

H. Other Wood Components. All appurtenant wood components such as battens, cover boards, skirt boards, etc. shall be the same species as used in the wall, No. 2 or better, and shall be S4S.

I. Metal Hardware. All metal hardware, including bolts and nuts, washers, screws, nails, etc. shall be either stainless steel, or galvanized steel, or aluminum. The same type shall be used throughout each individual installation.

J. Preformed Joint Filler. Preformed joint filler shall comply with AASHTO M 153 for Types I, II, or III; or AASHTO M 213.

K. Preservative Treatment. All wood products shall be preservative treated in accordance with the AWPA specification listed below. Any preservative listed in the applicable AWPA specification may be used, except

creosote or creosote solutions will not be permitted. The plans may include additional restrictions on preservative materials for items to be stained or painted.

<i>ITEM</i>	<i>TREATMENT REQUIRED</i>
Round Posts	AWPA C 14 for "Piles for Foundation, Land, or Fresh Water Use"
Sawn Posts	AWPA C 14 for "Lumber for Bridges, Structural Members, Decking, Cribbing, and Culverts"
Laminated Wood	AWPA C 28 for Ground Posts Contact
Lumber (Planks, framing lumber, pieces, etc...)	AWPA C 14 for "Lumber for Bridges, Structural Members, Decking, Cribbing, and Culverts" trim
Plywood	AWPA C9 for Soil Contact

Note: If water-borne preservatives are used for planks, the moisture content after treatment shall not exceed 15 percent.

L. Shop Drawings. The Contractor shall submit shop drawings for review by the Engineer, showing top and bottom elevations of the panels, finished grade line and theoretical sound attenuation line. Any fabrication begun on the sound barrier before the Engineer's review of the shop drawings is completed will be at the Contractor's risk.

The Contractor is responsible for determining the actual ground elevations at the location of the barrier, and the post length and panel height necessary.

M. Design Load. The barrier shall be designed to withstand the wind load required by the plans.

III. CONSTRUCTION REQUIREMENTS

A. General. The wood sound barrier shall be constructed in accordance with the plans. All fasteners shall be installed so the barrier is structurally sound, and to prevent sound leaks. The face of the completed barrier shall not

deviate from the vertical more than 4 mm in one meter (1/2 inch in 10 feet). Horizontal alignment shall be uniform, with no significant irregularities.

B. Foundation Design. If solid rock is encountered above the bottom-of-post elevations required by the plans, the Contractor may submit an alternate post foundation design for review by the Engineer. Before preparing an alternate foundation design, the Contractor should contact the Engineer to obtain the design criteria that must be met. The proposed design shall include all calculations. If the Engineer determines that the proposed design is not acceptable, then the post foundations shall be constructed in accordance with the plans.

No extension of contract time for delay during review of the proposed design will be considered. No increase will be made in the contract unit price for the wood sound barrier as a result of permitting a change in the post foundation design.

IV. METHOD OF MEASUREMENT

The wood sound barrier will be measured in square meters (square feet) of exposed front wall surface (facing the roadway) complete in place, calculated by multiplying the length of each section by the design height shown on the plans. The design height of each section will be the average vertical dimension from the theoretical sound attenuation line to the finished grade line shown on the plans. This height will be the minimum height required to achieve the desired sound attenuation, as determined from analysis of site characteristics. The actual height of barrier sections used will depend on the post spacing and panel arrangement employed.

The final pay quantity will be the design quantity. No additional payment will be allowed if the barrier sections used exceed the design height.

V. BASIS OF PAYMENT

The quantity of acceptably completed wood sound barrier, measured as above, will be paid for at the contract unit price per square meter (square foot). Such payment shall be full compensation for all labor, materials, equipment and incidentals necessary to furnish and install the barrier, including excavation, concrete, and backfill necessary to install the posts and wall, clearing and grubbing or trimming vegetation that would interfere with

erection of the barrier, restoration to the original grade of any portion of the existing roadway or shoulder damaged by construction of the sound barrier, and disposal of surplus materials from foundation excavations.

Payment will be made under:

<i>Pay Item</i>	<i>Pay Unit</i>
Wood Sound Barrier	Square Meter or Square Foot

APPROVED Signature on File 4/1/94
J. M. YOWELL, P.E. DATE
STATE HIGHWAY ENGINEER

**KENTUCKY DEPARTMENT OF HIGHWAYS
SPECIAL PROVISION NO. 60 (9-4)
CONCRETE SOUND BARRIER**

This Special Provision shall apply when indicated on the plans or in the proposal. Section references herein are to the Department's 1994 Standard Specifications for Road and Bridge Construction.

I. DESCRIPTION

This work shall consist of construction of a concrete sound barrier in accordance with the requirements of this Special Provision, the 1994 Standard Specifications, the plans, and proposal.

Four types of concrete walls are covered, as follows:

- Type A — Concrete Masonry Units
- Type B — Precast Interlocking Concrete Modules
- Type C — Precast Concrete Panels
- Type D — Cast-in-Place

The plans will indicate the type permitted at each location.

II. MATERIALS

A. Type A Barrier.

(1) Wall blocks shall be manufactured in accordance with ASTM C 90 for Grade N Type I hollow load-bearing concrete units.

(2) Mortar shall be portland cement mortar type PM in accordance with ASTM C 476.

(3) Concrete for piers, fill for masonry columns, and concrete caps shall be Class A.

B. Type B Barrier. Precast interlocking modules and precast concrete caps shall be as manufactured by the Doublewal Corporation, Plainville, Connecticut. Both faces of the barrier shall receive the surface treatment specified on the plans.

C. Type C Barrier. Precast concrete panels, and other precast elements, shall comply with Section 605 and all details on the plans. Class of concrete and surface finish shall be in accordance with the plans.

D. Concrete. Concrete for Type D Barriers, and foundations or footings for all barriers, shall be Class A.

E. Preformed Joint Filler. Preformed joint filler shall comply with AASHTO M 153 for Types I, II or III; or AASHTO M 213.

F. Steel Reinforcement. Steel reinforcement for all uses shall comply with ASTM A 615(m), grade 400.

G. Shop Drawings. The Contractor shall submit shop drawings for review by the Engineer, showing top and bottom elevations of the panels or wall sections, finished grade line and theoretical sound attenuation line. Any fabrication or construction begun on the sound barrier before the Engineer's review of the shop drawings is completed will be at the Contractor's risk.

The Contractor is responsible for determining the actual ground elevations at the location of the barrier, and the post or column length and panel height necessary if applicable.

H. Design Load. The barrier shall be designed to withstand the wind load required by the plans.

III. CONSTRUCTION REQUIREMENTS

A. General. Concrete sound barrier shall be constructed in accordance with the plans and approved shop drawings. Joints shall be constructed so the barrier is structurally sound, and sound leaks are prevented. The face of the completed barrier shall not deviate from the vertical more than 4 mm in one meter (1/2 inch in 10 feet). Horizontal alignment shall be uniform, with no significant irregularities.

B. Foundation Design. If solid rock is encountered above the bottom-of-post or bottom of footing elevations required by the plans, the Contractor may submit an alternate foundation design for review by the Engineer. Before preparing an alternate foundation design, the Contractor

should contact the Engineer to obtain the design criteria that must be met. The proposed design shall include all calculations. If the Engineer determines that the proposed design is not acceptable, then the foundations shall be constructed in accordance with the plans.

No extension of contract time for delay during the review of the proposed design will be considered. No increase will be made in the contract unit price for the concrete sound barrier as a result of permitting a change in foundation design.

IV. METHOD OF MEASUREMENT

Concrete sound barriers of each type will be measured in square meters (square feet) of exposed front wall surface (facing the roadway) complete in place, calculated by multiplying the length of each section by the design height shown on the plans. The design height of each section will be the average vertical dimension from the theoretical sound attenuation line to the finished grade line shown on the plans. This height will be the minimum height required to achieve the desired sound attenuation, as determined from analysis of site characteristics. The actual height of barrier sections used will depend on the configuration of the type of barrier constructed.

The final pay quantity will be the design quantity. No additional payment will be allowed if the barrier as constructed exceeds the design height.

V. BASIS OF PAYMENT

The quantity of acceptably completed concrete sound barrier of each type, measured as above, will be paid for at the contract unit price per square meter (square foot). Such payment shall be full compensation for all labor, materials, equipment and incidentals necessary to furnish and install the barrier, including excavation, concrete, steel reinforcement, and backfill necessary to construct the foundation and the complete wall, clearing and grubbing or trimming vegetation that would interfere with erection of the barrier, restoration to the original grade of any portion of the existing roadway or shoulder damaged by construction of the sound barrier, and disposal of surplus materials from foundation excavations.

Payment will be made under:

Pay Item

Pay Unit

Concrete Sound Barrier (Type)

Square Meter or Square Foot

APPROVED Signature on File 4/1/94
J. M. YOWELL, P.E. DATE
STATE HIGHWAY ENGINEER

SPECIAL NOTE FOR GABIONS AND MATTRESS UNITS

In addition to the requirements of Section 813.14 of the Kentucky Standard Specifications for Road and Bridge Construction all mesh for mattress units shall be triple twisted.

In addition to the requirements of Sections 813.14 and 813.15 all perimeter edges of the mesh forming mattress units and gabion baskets shall be triple twisted so that seams shall have at least the same strength as the body of the mesh.

As an alternate to lacing wire, as specified in Sections 813.14 and 813.15, Tiger-Tite Interlocking Fasteners manufactured by Jackson clip company, Mazie, Oklahoma may be used. The Contractor shall provide brochures to the Engineer and shall follow the manufacturer's recommendations for assembly and connection.

February 7, 1992

**KENTUCKY TRANSPORTATION CABINET
DEPARTMENT OF HIGHWAYS
SPECIAL PROVISION NO. 66L (94)**

CONCRETE RETAINING WALLS

This Special Provision shall apply when indicated on the plans or in the proposal. Section references herein are to the Department's 1994 Standard Specifications for Road and Bridge Construction.

I. DESCRIPTION

This work shall consist of the construction of retaining walls consisting of cast-in-place reinforced concrete or precast concrete elements, in reasonably close conformity with the lines, grades, design, and dimensions shown on the plans or established by the Engineer.

II. MATERIALS

A. General. Unless specified otherwise elsewhere in the contract the wall may be, at the Contractor's option, either of the following, except Evergreen walls are considered experimental and may be used only when included in the original plans.

- (1) Cast-in-Place Reinforced Concrete.
- (2) Doublewal®, as sold by the Doublewal Corporation, 59 East Main Street, Plainville, Connecticut 06062.
- (3) Evergreen®, as sold by Evergreen Systems, Inc., 140 Old Northport Road, Kings Park, New York 11754.
- (4) Hilfiker Reinforced Soil Embankment®, as sold by Hilfiker Texas Corporation, 621 West Hurst Boulevard, Hurst, Texas 76053.
- (5) Reinforced Earth®, as sold by the Reinforced Earth Company, 7003 Chadwick Drive, Suite 355, Brentwood, Tennessee 37027
- (6) VSL Retained Earth™, as sold by VSL Corporation, P. O. Box 866, 8006 Haute Court, Springfield, Virginia 22150.

The various materials used in manufacture of the wall elements shall meet the requirements specified hereinafter. The same material shall be

used throughout any individual wall, or at both ends of any individual structure, unless otherwise shown on the plans. All materials shall be approved before use.

When precast walls are constructed, the seller of the wall elements shall provide a technical representative to assist the fabricator, Contractor, and Engineer on the project until they are familiar and confident in casting, installation, and construction procedures required. The technical representative shall be available to assist in the event unusual problems or special circumstances arise. Technical assistance shall be provided at no additional cost to the Department.

Production of precast concrete elements shall conform to the requirements of Section 605, unless specifically modified herein.

B. Cast-in-Place. All materials used in cast-in-place reinforced concrete retaining walls shall comply with the Department's Standard Specifications.

If the plans do not include a complete design for a cast-in-place reinforced concrete retaining wall, the Contractor shall be responsible for providing the design and details.

When the Contractor provides the design, the following criteria shall apply:

- (1) The wall shall be designed by a Registered Professional Engineer prequalified to prepare structure plans for the Department.
- (2) The design shall conform to the AASHTO Standard Specifications for Highway Bridges, current edition and all published interim specifications.
- (3) Class A concrete shall be used.

(4) Grade 400 (60) steel reinforcement shall be used.

(5) The minimum thickness of the top of the wall shall be 229 mm (9 inches), unless otherwise shown on the plans.

(6) The design shall comply with all dimensions that may be shown on the plans, and shall accommodate all other features of the project as shown on the plans. The front face of the retaining wall shall conform to the plan layout.

(7) The allowable bearing pressure of the foundation soils, the unit weight of the retained soils, and the characteristics of the retained soils necessary for design purposes shall be obtained from the Division of Materials. The supporting footing of the wall shall be of such size that no additional right-of-way will be needed to accommodate the footing. All necessary surcharges shall be incorporated into the design.

(8) The Contractor shall submit to the Division of Bridges for review 3 full sets of design drawings and all calculations. Original drawings shall be prepared on drafting film furnished by the Department. One set, reviewed and with noted corrections to be made, will be returned to the Contractor. When corrections are to be made, 3 full sets of drawings and calculations shall be submitted each time corrections are made. After final review is completed, the Contractor shall furnish the Division of Bridges one full set of drafting film drawings of the reviewed drawings, which will produce clear prints and microfilms. The final drawings shall be 559 to 610 mm (22 to 24 inches) wide by 914 mm (36 inches) in length.

(9) A Masonry Coating Finish, as described in Section 601.26, Part B is required.

(10) The complete preparation of the design and all required corrections to the design shall be at the Contractor's expense, except for the review by the Department. No additional contract time will be allowed for the design detailing or review of the cast-in-place wall.

(11) Any materials furnished or work performed before the Department's review of the proposed design is completed shall be at the Contractor's risk.

C. Doublewal.

(1) **Precast Units.** Concrete for the precast modular units shall attain a minimum 28 day compressive strength of 34.47 MPa (5,000 psi). Concrete for other features shall attain a minimum 28 day compressive strength of 20.68 MPa (3,000 psi). All concrete shall be air entrained containing 5.5 ± 1.5 percent entrained air at the time concrete is deposited in the forms.

A proposed mix design shall be submitted as specified in Section II.A.

(2) **Reinforcing Bars.** Reinforcing bars shall be grade 400 (60) and shall conform to ASTM A 615, A 616, or A 617, except No. 3 stirrups may be grade 300 (40).

(3) Joint Filler.

(a) No filler is required in vertical joints.

(b) Cork filler for horizontal joints shall conform to AASHTO M 153, Type II. Rubber bearing pads shall be a type and grade recommended by the Doublewal Corporation. Backer rod shall be a premium grade closed cell polyethylene foam. All joint materials shall be installed in accordance with the plans and/or approved shop drawings.

(c) All joints between modules shall be covered on the back side of the front face of the wall and on the back side of the back of the wall by a geotextile fabric. The fabric shall meet the requirements of Section 845, Table I.

The minimum width and lap of the fabric sheets shall be as follows:

Vertical joints - 305 mm (12 inches)
Horizontal joints - 305 mm (12 inches)
All laps in fabric - 102 mm (4 inches)

(d) All joint materials shall be furnished by the Doublewal manufacturer or supplier.

(4) **Tolerances.** Minimum tolerance for the manufacture of Doublewal units are as follows: Face of panel, length or height: ± 4.8 mm (3/16 inch)

Deviation from square measured on diagonal: 7.9 mm (5/16 inch)

Location of reinforcement steel: cover tolerance -6.4 to 12.7 mm (-1/4 to +1/2 inch), otherwise within ± 6.4 mm (1/4 inch).

(5) **Forms.** Forms for the units shall be constructed of steel in a manner that will assure the production of uniform units, and shall remain in place until they can be removed without damage to the unit.

(6) **Mixing and Placing Concrete.** The concrete mix as designed shall be proportioned and mixed in a batch mixer to produce a homogeneous concrete conforming to the requirements. The transporting, placing, and compacting of concrete shall be by methods that will prevent segregation of the concrete materials and the displacement of the steel reinforcement from its proper position in the form. Concrete shall be carefully placed in the forms and vibrated sufficiently to produce a surface free from imperfections such as honeycomb, segregation, or cracking. Clear form oil of the same manufacture shall be used throughout the casting operation.

(7) **Curing.** The units shall be properly cured for a sufficient time so that the concrete will develop the specified compressive strength.

(8) **Testing and Inspection.** Acceptability of the precast units will be determined on the basis of entrained air in the concrete mixture, compression tests, and visual inspection. The Contractor or his supplier shall furnish facilities and the Certified Concrete Technician shall perform all necessary sampling and testing in an expeditious and satisfactory manner. Acceptance will be as specified in paragraph II.N herein.

(9) **Finish.** Concrete surface shall be ordinary surface finish unless otherwise shown on the plans.

(10) **Marking.** The date of manufacture

shall be clearly scribed or painted with waterproof paint on an interior surface of each unit.

(11) **Handling, Storing, and Shipping.** All units shall be handled, stored, and shipped in such manner as to eliminate the danger of chipping, cracks, fractures and excessive bending stresses.

D. Evergreen.

(1) **Precast Units.** Concrete for the precast units shall attain a minimum 28 day compressive strength of 34.47 MPa (5,000 psi). All concrete shall be air entrained containing 5.5 ± 1.5 percent entrained air at the time concrete is deposited in the forms.

A proposed mix design shall be submitted as specified in Section II.A.

(2) **Steel Reinforcement.** Reinforcing bars shall be grade 400 (60) and shall conform to ASTM A 615, A 616, or A 617. Welded steel wire fabric shall conform to ASTM A 185.

(3) **Mortar.** Mortar for setting precast units shall be a quick-set mortar recommended by the wall manufacturer.

(4) **Tolerances.** Minimum tolerance for the manufacture of Evergreen units shall be as follows:
All dimensions within ± 4.8 mm (3/16 inch)

(5) **Forms.** Forms for the units shall be constructed of steel in a manner that will assure the production of uniform units, and shall remain in place until they can be removed without damage to the unit.

(6) **Mixing and Placing Concrete.** The concrete mix as designed shall be proportioned and mixed in a batch mixer to produce a homogeneous concrete conforming to the requirements. The transporting, placing, and compacting of concrete shall be by methods that will prevent segregation of the concrete materials and the displacement of the steel reinforcement from its proper position in the

form. Concrete shall be carefully placed in the forms and vibrated sufficiently to produce a surface free from imperfections such as honeycomb, segregation, or cracking. Clear form oil of the same manufacture shall be used throughout the casting operation.

(7) **Curing.** The units shall be properly cured for a sufficient time so that the concrete will develop the specified compressive strength.

(8) **Testing and Inspection.** Acceptability of the precast units will be determined on the basis of entrained air in the concrete mixture, compression tests, and visual inspection. The Contractor or his supplier shall furnish facilities and the Certified Concrete Technician shall perform all necessary sampling and testing in an expeditious and satisfactory manner. Acceptance will be as specified in paragraph II.N herein.

(9) **Finish.** Concrete surface shall be ordinary surface finish unless otherwise shown on the plans.

(10) **Marking.** The date of manufacture shall be clearly scribed or painted with waterproof paint on an interior surface of each unit.

(11) **Handling, Storing, and Shipping.** All units shall be handled, stored, and shipped in such manner as to eliminate the danger of chipping, cracks, fractures, and excessive bending stresses. Units in storage shall be supported on firm blocking to avoid twisting or cracking.

E. Hilfiker Reinforced Soil Embankment

(1) **Precast Facing Panels.** Concrete for the precast facing panels shall attain a minimum 28 day compressive strength of 27.58 MPa (4,000 psi). The concrete shall be air entrained containing 5.5 ± 1.5 percent entrained air at the time concrete is deposited in the forms.

A proposed mix design shall be submitted as specified in Section II.A.

All embedded items and lifting devices shall be set in place as shown on the plans prior to casting.

(a) **Testing and Inspection.** Acceptability of the completed facing panels will be determined on the basis of entrained air in the concrete mixture, compression tests, and visual inspection. The Contractor or his supplier shall furnish facilities and the Certified Concrete Technician shall perform all necessary sampling and testing in an expeditious and satisfactory manner. Acceptance will be as specified in paragraph II.N hereinafter.

(b) **Casting.** The panels shall be cast front-face down on a flat surface. The concrete in each unit shall be placed without interruption and shall be consolidated by the use of a vibrator, supplemented by such hand-tamping as may be necessary to force the concrete into the corners of the forms and prevent the formation of honeycomb or cleavage planes. Clear form oil of the same manufacture shall be used throughout the casting operation.

(c) **Curing.** The units shall be cured for a sufficient time so that the concrete will develop the specified compressive strength.

(d) **Forms.** Forms for the panels shall be constructed of steel in a manner that will assure the production of uniform panels, and shall remain in place until they can be removed without damage to the unit.

(e) **Concrete Finish and Tolerances.** The concrete surface for the front face shall be ordinary surface finish unless otherwise shown on the plans, and for the rear face floated surface finish. The rear face of the panel shall be screeded to eliminate open pockets of aggregates and surface distortions in excess of 6.4 mm (1/4 inch).

(f) **Tolerances.** All units shall be manufactured within the following tolerances:

All dimensions within 6.4 mm (1/4 inch).

Angular distortion with regard to height of panels shall not exceed 4 mm in one meter (0.25 inch in 5 feet).

Surface defects on formed surfaces measured over a length of 1.52 m (5 feet) shall not

exceed 2.5 mm (0.10 inch) on smooth surfaces or 7.9 mm (5/16 inch) on textured surfaces.

(2) **Marking.** The date of manufacture, the lot number, and the piece-mark shall be clearly scribed or painted with waterproof paint on the rear face of each panel.

(3) **Handling, Storing, and Shipping.** All units shall be handled, stored, and shipped in such a manner as to eliminate the danger of chipping, cracks, fractures, and excessive bending stresses.

At least 6.89 MPa (1,000 psi) compressive strength shall be attained before the panels may be handled.

(4) **Steel Mesh Soil Reinforcement.** The mesh shall meet the requirements of ASTM A 82 for cold drawn wire and shall be welded into the finished mesh fabric in accordance with ASTM A 185. Mat anchors and reinforcing mesh shall be galvanized in accordance with ASTM A 123 after fabrication. Wire size and mesh configuration shall be as shown on the plans.

Panel anchors and connection pins shall conform to ASTM A 82, and shall be galvanized in accordance with ASTM A 123 after fabrication.

(5) **Reinforcing Bars.** Reinforcing bars may be either grade 40, 50, or 60 and shall conform to ASTM A 615, A 616, or A 617. Welded wire fabric used for concrete reinforcement shall conform to ASTM A 82 and ASTM A 185.

(6) Joint Filler.

(a) Bearing pads and joint filler shall be as recommended by the Hilfiker Company.

(b) All joints between panels shall be covered on the back side of the wall with geotextile fabric. The fabric shall meet the requirements of Section 845, Table I. The minimum width and lap of the fabric sheets shall be as follows:

- Vertical joints - 457 mm (18 inches)
- Horizontal joints - 305 mm (12 inches)
- All laps in fabric - 102 mm (4 inches)

(c) All joint materials shall be furnished by the Hilfiker manufacturer or supplier.

Concrete in leveling pads shall have a minimum compressive strength of 17.24 MPa (2,500 psi) at 28 days.

(8) **Cast-in-Place Coping.** Concrete in copings shall have a minimum compressive strength of 27.58 MPa (4,000 psi) at 28 days.

F. Reinforced Earth.

(1) **Concrete Face Panels.** Concrete shall have a minimum compressive strength of 27.58 MPa (4,000 psi) at or before 28 days. The concrete shall be air-entrained and contain 5.5 ± 1.5 percent entrained air at the time the concrete is placed in the forms.

A proposed mix design shall be submitted as specified in Section II.A.

Tie strips, reinforcing bars, connecting pins, and PVC tubes and lifting and handling devices shall be set in place to the dimensions and tolerances shown on the plans or as approved by the Engineer prior to casting.

(a) *Testing and Inspection.* Acceptability of the completed precast panels will be determined on the basis of entrained air in the concrete mixture, compression tests, and visual inspection. The Contractor or his supplier shall furnish facilities and the Certified Concrete Technician shall perform all necessary sampling and testing in an expeditious and satisfactory manner. Acceptance will be as specified in paragraph II.N hereinafter.

(b) *Casting.* The panels shall be cast on a flat area, the front face of the form at the bottom. Tie strip guides shall be set on the rear face. The concrete in each unit shall be placed without interruption and shall be consolidated by the use of a vibrator, supplemented by such hand-tamping as may be necessary to force the concrete into corners of the forms and prevent formation of honeycomb or cleavage planes. Clear form oil of the same manufacture shall be used throughout the casting operation.

(c) *Curing.* The units shall be cured for a sufficient time so that the concrete will develop the specified compressive strength.

(d) *Forms.* Forms for the panels shall be constructed of steel in a manner that will assure the production of uniform panels, and shall remain in place until they can be removed without damage to the unit.

(e) *Concrete Finish.* The concrete surface for the front face shall be ordinary surface finish unless otherwise shown on the plans, and for the rear face floated surface finish. The rear face of the panel shall be screeded to eliminate open pockets of aggregate and surface distortions in excess of 6.4 mm (1/4-inch).

(f) *Tolerances.* All units shall be manufactured within the following tolerances:

Lateral position of tie strips within 25.4 mm (one inch).

All other dimensions within 14.8 mm (3/16-inch).

Angular distortion with regard to the height of the panel shall not exceed 3.3 mm in one meter (0.2 inch in 5 feet).

Surface defects on formed surfaces measured over a length of 1.52 m (5 feet) shall not exceed 2.5 mm (0.10 inch) on smooth surfaces or 7.9 mm (5/16 inch) on textured surfaces.

(2) *Marking.* The date of manufacture, the lot number, and the piece-mark shall be clearly scribed or painted with waterproof paint on the rear face of each panel.

(3) *Handling, Storing, and Shipping.* All units shall be handled, stored, and shipped in such manner as to eliminate the danger of chipping, cracks, fractures and excessive bending stresses. Panels in storage shall be supported on firm blocking located immediately adjacent to tie strips to avoid bending the tie strips.

(4) *Reinforcing and Tie Strips.* Tie strips shall be shop fabricated of hot rolled steel conforming to the minimum requirements of ASTM A 570, Grade 36 or Grade 50, or equivalent. They

shall be hot dip galvanized after fabrication to conform to minimum requirements of ASTM A 123. Reinforcing strips shall be hot rolled from bars to the required shape and dimensions. Their physical and mechanical properties shall conform to ASTM A 36, ASTM A 572 Grade 65, or equivalent. They shall be hot-dip galvanized after fabrication to conform to the minimum requirements of ASTM A 123.

Reinforcing and tie strips shall be cut to length and tolerances shown on the plans or approved shop drawings. Holes for bolts shall be punched in the locations shown, before galvanizing. All reinforcing and tie strips shall be carefully inspected to ensure they are true to size and free from defects that may impair their strength and durability.

(5) *Fasteners.* Bolts and nuts shall be hexagonal cap screw, high strength conforming to ASTM A 325 or equivalent, and galvanized. They shall be 12.7 mm (1/2 inch) in diameter, 32 mm (1 1/4 inch) in length with 19 mm (3/4 inch thread length).

(6) *Reinforcing Bars.* Reinforcing bars may be either grade 300, 400, 500 (40, 50, or 60) and shall conform to ASTM A 615, A 616, or A 617.

(7) *Joint Materials.*

(a) No filler is required in vertical joints.

(b) Rubber bearing pads for horizontal joints between panels shall be a type and grade recommended by the Reinforced Earth Company.

(c) All joints between panels shall be covered on the back side of the wall with geotextile fabric. The fabric shall meet the requirements of Section 845, Table I. The minimum width and lap of the fabric sheets shall be as follows:

Vertical joints - 457 mm (18 inches)

Horizontal joints - 305 mm (12 inches)

All laps in fabric - 102 mm (4 inches)

(d) All joint materials shall be furnished by

the Reinforced Earth manufacturer or supplier.

G. VSL Retained Earth.

(1) **Precast Facing Panels.** Concrete for the precast facing panels shall attain a minimum 28 day compressive strength of 27.58 MPa (4,000 psi). The concrete shall be air entrained containing 5.5 ± 1.5 percent entrained air at the time concrete is deposited in the forms.

A proposed mix design shall be submitted as specified in Section II.A.

Reinforcing mesh connections and lifting devices shall be set in place as shown on the plans prior to casting.

(a) *Testing and Inspection.* Acceptability of the completed facing panels will be determined on the basis of entrained air in the concrete mixture, compression tests, and visual inspection. The Contractor or his supplier shall furnish facilities and the Certified Concrete Technician shall perform all necessary sampling and testing in an expeditious and satisfactory manner. Acceptance will be as specified in paragraph II.N hereinafter.

(b) *Casting.* The panels shall be cast front-face down on a flat surface. The concrete in each unit shall be placed without interruption and shall be consolidated by the use of a vibrator, supplemented by such hand-tamping as may be necessary to force the concrete into the corners of the forms and prevent the formation of honeycomb or cleavage planes. Clear form oil of the same manufacture shall be used throughout the casting operation.

(c) *Curing.* The units shall be cured for a sufficient time so that the concrete will develop the specified compressive strength.

(d) *Forms.* Forms for the panels shall be constructed of steel in a manner that will assure the production of uniform panels, and shall remain in place until they can be removed without damage to the unit.

(e) *Concrete Finish and Tolerances.* The concrete surface for the front face shall be ordinary surface finish unless otherwise shown on the plans, and for the rear face floated surface finish. The rear

face of the panel shall be screeded to eliminate open pockets of aggregates and surface distortions in excess of 6.4 mm (1/4 inch).

(f) *Tolerances.* All units shall be manufactured within the following tolerances:

All dimensions within 4.8 mm (3/16 inch).

Angular distortion with regard to height of panels shall not exceed 2 mm in one meter (0.125 inch in 5 feet).

Surface defects on formed surfaces measured over a length of 1.52 m (5 feet) shall not exceed 2.5 mm (0.10 inch) on smooth surfaces or 7.9 mm (5/16 inch) on textured surfaces.

(2) **Marking.** The date of manufacture, the lot number, and the piece-mark shall be clearly scribed or painted with waterproof paint on the rear face of each panel.

(3) **Handling, Storing, and Shipping.** All units shall be handled, stored, and shipped in such a manner as to eliminate the danger of chipping, cracks, fractures, and excessive bending stresses.

(4) **Steel Mesh Soil Reinforcement.** The mesh shall meet the requirements of ASTM A 82 for cold drawn wire and shall be welded into the finished mesh fabric in accordance with ASTM A 185. The mesh panels shall be galvanized in accordance with ASTM A 123 after fabrication. Wire size and mesh configuration shall be as shown on the plans.

Clevis connectors shall be fabricated of cold drawn steel wire conforming to the requirements of ASTM A 82 and welded in accordance with ASTM A 185. Loops shall be galvanized in accordance with ASTM A 153 Class B-3, or ASTM A 123. Connector bars shall be fabricated of cold drawn steel wire conforming to the requirements of ASTM A 82 and galvanized in accordance with ASTM A 123.

The pins used to align the face panels during construction shall be 15.9 mm (5/8 inch) diameter, mild steel, round, smooth bar galvanized to meet ASTM A 123.

(5) **Reinforcing Bars.** Reinforcing bars may be either grade 300, 400, 500 (40, 50, or 60) and shall conform to ASTM A 615, A 616, or A 617.

(6) **Joint Filler.**

(a) No filler is required in vertical joints.

(b) Filler for horizontal joints between panels shall be preformed cork conforming to AASHTO M 153, Type II.

(c) All joints between panels shall be covered on the back side of the wall with geotextile fabric. The fabric shall meet the requirements of the current edition of Section 845, Table I. The minimum width and lap of the fabric sheets shall be as follows:

- Vertical joints - 457 mm (18 inches)
- Horizontal joints - 305 mm (12 inches)
- All laps in fabric - 102 mm (4 inches)

H. Cement. Cement used in the precast elements shall conform to Section 801 or ASTM C 150, Type I or II.

I. Chemical Admixtures. Chemical admixtures shall conform to Section 802.

J. Granular Fill Materials. All fill material placed within the reinforced volume if Hilfiker Reinforced Soil Embankment, Reinforced Earth, or Retained Earth is used, and all material used for filling the modular units if Doublewal or Evergreen is used, shall have 100% passing the 100 mm (4 inch) sieve, and shall have no more than 5 percent passing the 75µm (No. 200) sieve when tested by KM 64-606. Acceptability of the material may be based on visual inspection by the Engineer when the material includes a significant amount of individual fragments greater than 38 mm (1 1/2 inches).

Granular fill shall be reasonably free of shale or other deleterious material. The quality of all granular materials shall be acceptable to the Engineer.

All fill material placed within the reinforced

volume if either Hilfiker Reinforced Soil Embankment, Reinforced Earth walls, or Retained Earth walls are used shall meet the following additional requirements:

REQUIREMENT	TEST METHOD
Resistivity >3,000 ohm-cm*	Calif. DOT 643
pH 5-10	Calif. DOT 643
chlorides <200 parts per million	Calif. DOT 422
sulfates <1,000 parts per million	Calif. DOT 417
Angle of internal friction	≥ 34°

*Applicable only when granular fill has more than 50% passing the 4.75 mm (No. 4) sieve.

Testing to determine the angle of internal friction will normally not be required; however, gap-graded materials, single-size aggregates, natural sand, uncrushed gravel, or blends including uncrushed gravel, shall not be used unless the supplier furnishes a test report showing the 34° minimum internal friction angle is met. Testing shall be determined by AASHTO T 236 for direct shear testing, utilizing a sample of the material compacted to 95% of AASHTO T 99 Methods C or D (with oversize correction as outlined in Note 7) at optimum moisture content. When such materials are approved for use based on submitted test reports, the Engineer will perform sampling and testing on the project as necessary to assure that the material furnished is closely similar to that approved.

Material that is Size No. 57 or larger, except crushed or uncrushed gravel, is considered to be non erodible.

The following materials are considered to be erodible or unstable:

- (1) Friable sandstone
- (2) Crushed or Uncrushed gravel, any size
- (3) Crushed coarse aggregate (other than gravel) smaller than Size No. 57.
- (4) Any material with 50% or more passing the 4.75 mm (No. 4) sieve.

Sandstone will be judged to be friable or non-friable by the Engineer.

These erodible or unstable materials may erode even when protected by riprap or channel lining. In addition to the above requirements, when the Contractor elects to furnish granular fill materials composed of material having 50 percent or more passing a 4.75 mm (No. 4) sieve and which will be either exposed in the finished work or protected only by riprap or channel lining, the exposed surfaces or surfaces beneath the riprap or channel lining shall be protected by geotextile fabric meeting the requirements of Section 845, Table I. Fabric shall be covered a minimum of one foot deep with non-erodible material. The fabric shall extend over the entire area of the granular fill material that would otherwise be exposed, or protected only by rip rap or channel lining, in the finished work.

For erodible or unstable materials having less than 50 percent passing a 4.75 mm (No. 4) sieve, the one-foot protective cover shall be placed, but the geotextile fabric is not required.

K. Concrete. Concrete for footings, leveling pads, cast-in-place copings, or other cast-in-place appurtenances shall be Class A conforming to Section 601, unless otherwise specified.

L. Shop Drawings. Before fabrication, the Contractor shall submit 3 sets of shop drawings to the Engineer for review. Separate sets of shop drawings shall be prepared and submitted for each structure. These drawings shall include layout plans, concrete footing dimensions and reinforcement details including design calculations when appropriate, details of stepped installation on grades, material lists and type of finish requirements. The materials list shall itemize all material required in addition to the concrete units -- soil reinforcement; connection hardware including nuts, bolts, and washers; and any other auxiliary materials that will be incorporated into the finished installation. The Contractor shall furnish 8 sets of completed shop drawings after the Engineer's review is complete and any necessary corrections made. Any fabrication begun on the wall elements before

the Engineer's review of the shop drawings is completed will be at the Contractor's risk. The shop drawings shall include or be accompanied by step-by-step erection instructions. No field work shall be performed until the completed shop drawings and erection instructions have been received by the Engineer.

M. Manufacturer. Section 107.05, covering the use of patented devices, materials, and processes shall apply.

When a special or decorative surface finish is required, the manufacturer shall display for approval typical samples of the face panels or modular units indicating the color, texture, and finish he intends to use. All precast elements shall reasonably conform in appearance to the approved samples.

Before shipment, surfaces of all precast elements shall be examined. All excessive voids and other defects in the exterior wall surfaces shall be properly patched as required to conform to the balance of the work with respect to appearance, strength and durability.

The precast units shall not be shipped before attaining the required concrete strength.

N. Acceptance. All materials used in manufacture of the precast elements, including cement, aggregates, water, admixtures, concrete mixtures, steel reinforcement, and galvanized metal items will be sampled and tested according to the Department's standard procedures for these items. Fabrication shall not begin until these materials have been approved.

Fabrication of the precast elements is subject to random inspection by the Department. Compressive strength tests may be performed by either the Department, an approved independent laboratory, or by the precast fabricator, as approved by the Engineer. Tests performed by the precast fabricator will normally be witnessed by the Department inspector. Results of all tests required to be performed by the fabricator on the properties of the concrete mixtures and compressive strength results shall be furnished to the District Materials Engineer.

Completed precast elements will be inspected before shipment and damaged or otherwise unsatisfactory elements will be rejected. Elements damaged during handling, transporting, erecting, or backfilling, or any element that cannot be placed satisfactorily in the wall shall be repaired or replaced, as directed or approved by the Engineer.

III. CONSTRUCTION REQUIREMENTS

A. General. The foundation bed for the precast concrete retaining wall shall be excavated as required, and shall be approved by the Engineer before erection is started. If required by the plans or ordered by the Engineer, granular backfill shall be placed to the dimensions required under the footings or bottom units.

Cast-in-place footings or leveling pads for precast walls when shown on the project plans, shall conform to the dimensions and details indicated and shall be placed at least 24 hours before placement of Reinforced Earth or Retained Earth units, or 72 hours before placement of Doublewal or Evergreen units. Doublewal or Evergreen units may be placed in less than 72 hours providing the footing concrete attains a compressive strength of at least 13.79 MPa (2,000 psi); Type III cement or an increased cement content may be used at the Contractor's option, at no additional cost to the Department.

Precast concrete elements shall be installed in accordance with the manufacturer recommendations as shown on the shop drawings. Special care shall be taken in setting the bottom course of elements to true line and grade.

The wall shall be cambered when required by the plans to compensate for anticipated settlement.

Perforated pipe shall be placed behind each retaining wall as shown on the plans or directed by the Engineer.

B. Wall Erection.

(1) **Cast-in-Place.** Construction procedures for cast-in-place retaining walls shall comply with the Department's Standard Specifications.

(2) **Doublewal.** The foundation for the structure shall be graded level for the width necessary to prepare the foundation and place the footing, or wider when shown on the plans. Prior to wall construction, the foundation shall be compacted as directed. Any foundation soils found to be unsuitable shall be removed and replaced.

All modular units above the first course shall interlock with lower courses. Vertical joints shall be staggered with each successive course or as shown on the plans. The vertical joint opening on the front face of the wall shall not exceed 19 mm (3/4 inch). Joint filler shall be installed in the horizontal joints in accordance with the plans and approved shop drawings. Joints at corners or angle points shall be closed in accordance with recommendations of the manufacturer.

Repairs at the job site shall be done by experienced personnel utilizing methods and materials recommended by the manufacturer and approved by the Engineer. Patching will be done only when conditions exist which assure that the repaired area will conform to the balance of the work with respect to appearance, strength, and durability.

The interior of each successive course of precast modular units shall be filled with granular fill material described in paragraph II. J herein. Units 1.22 m (4 feet) or less in height shall be filled in one layer and then thoroughly consolidated with a vibratory tamping device. Units which are more than 1.22 m (4 feet) in height shall be filled in two approximately equal layers and thoroughly consolidated after each layer is placed.

Backfill around the outside of the wall, as shown on the plans or directed, shall be placed in layers not exceeding 203 mm (8 inches) loose depth. Each layer shall be thoroughly compacted in accordance with the project requirements for embankment.

When erecting a battered wall, placement of backfill behind the wall shall closely follow erection of successive courses of units. At no time shall the difference in elevation between the backfill and the top of the last erected course exceed 1.83m (6 feet).

Any wall materials which are damaged or disturbed during backfill placement shall be either

removed and replaced or corrected, as directed or approved by the Engineer, at the Contractor's expense.

(3) **Evergreen.** The foundation for the structure shall be graded level for the width necessary to prepare the foundation and place the footing. Prior to wall construction, the foundation shall be compacted as directed. Any foundation soils found to be unsuitable shall be removed and replaced.

When on-site stockpiling of Evergreen units is necessary, the units shall be stored on a timber foundation to avoid uneven deformation, twisting, or cracking.

The first layer of precast units shall be carefully set to grade using wedges and quick-set mortar; succeeding layers shall be set using screw bolts and quick-set mortar, all in accordance with the plans and the manufacturer's instructions.

The interior of each successive course of units shall be filled with granular fill material described in paragraph II. J herein. The units shall be filled in one layer and thoroughly consolidated with a vibratory tamping device. Topsoil material shall be placed at the outer front edge only when specified on the plans.

Backfill around the outside of the wall, as shown on the plans or directed, shall be placed in layers not exceeding 203 mm (8 inches) loose depth. Each layer shall be thoroughly compacted in accordance with the project requirements for embankment.

When erecting a battered wall, placement of backfill behind the wall shall closely follow erection of successive layers of units. At no time shall the difference in elevation between the backfill and the top of the last erected course exceed 1.83 m (6 feet).

Any wall materials which are damaged or disturbed during backfill placement shall be either removed and replaced or corrected, as directed or approved by the Engineer, at the Contractor's expense.

(4) **Hilfiker Reinforced Soil Embankment.** The foundation for the structure shall be graded level for a width equal to the length

of mesh reinforcement mats plus 152 mm (6 inches) or as shown on the plans. Prior to wall construction, the foundation shall be compacted by at least 3 passes of an 7.3 metric ton (8-ton) smooth wheel vibratory roller. Any foundation soils found to be unsuitable shall be removed and replaced. Precast leveling pads shall be placed in accordance with the supplier's instructions.

Concrete facing panels should be placed in successive horizontal lifts in the sequence shown on the plans or approved shop drawings as backfill placement proceeds. As granular fill material is placed behind a panel, the panels should be maintained in vertical position by means of temporary wooden wedges or bracing.

Backfill placement shall closely follow the erection of each lift of panels. At each mat level, backfill should be compacted and roughly leveled before placing mesh reinforcing. As shown on the plans, reinforcement shall be placed normal to the face of the wall. The maximum lift thickness shall not exceed 203 mm (8 inches) (loose) and shall closely follow panel erection. This lift thickness shall be decreased if necessary to obtain the specified compaction.

Backfill shall be compacted to 95 percent of the maximum density as determined by KM 64-511. A method of compaction consisting of at least 4 passes by a vibratory roller weighing at least 4.5 metric tons (5 tons) shall be used. For applications where spread footings are used to support bridge or other structural loads, the top 1.52 m (5.0 feet) below the footing elevation shall be compacted to 100 percent of the maximum density.

The moisture content of the backfill material prior to and during compaction shall be uniformly distributed throughout each layer. Backfill materials shall have a placement moisture content less than or equal to the optimum moisture content. Backfill material with a placement moisture content in excess of the optimum moisture content shall be removed and reworked until the moisture content is uniformly acceptable throughout the entire lift.

Compaction within three feet of the back face of the wall shall be achieved by at least three passes of a lightweight mechanical tamper, roller, or

vibratory system.

At the end of each day's operation the Contractor shall slope the last level of the backfill away from the wall facing to rapidly direct runoff away from the wall face. In addition, the Contractor shall not allow surface runoff from adjacent areas to enter the wall construction site.

Geotextile fabric shall be installed as specified in Section II.J herein.

Vertical tolerances and horizontal alignment tolerance shall not exceed 19 mm (3/4 inch) when measured along a 3.05 m (10-foot) straight edge. The maximum allowable offset in any panel joint shall be 19 mm (3/4 inch). The overall vertical tolerance of the wall (plumbness from top to bottom) shall not exceed 4 mm in one meter (1/2 inch per 10 feet) of wall height.

Any wall materials which become damaged or disturbed during backfill placement shall be either removed and replaced or corrected as directed or approved by the Engineer, at the Contractor's expense. Any misalignment or distortion of the wall facing panels due to placement of backfill outside the limits of this specification shall be corrected as directed or approved by the Engineer.

(5) Reinforced Earth. The foundation for the structure shall be graded level for a width equal to or exceeding the length of reinforcing strips or as shown on the plans. Prior to wall construction, the foundation shall be compacted with a smooth wheel vibratory roller. Any foundation soils found to be unsuitable shall be removed and replaced.

Precast concrete panels shall be aligned vertically using inserts cast into the top edge of panels. Panels should be placed in successive horizontal lifts in the sequence shown on the plans or approved shop drawings as backfill placement proceeds. As granular fill material is placed behind a panel, the panels should be maintained in vertical position by means of temporary wooden wedges placed in the horizontal joint at the junction of the two adjacent panels on the external side of the wall. External bracing is required for the initial lift.

Backfill placement shall closely follow the erection of each lift of panels. At each reinforcing strip level, backfill should be compacted and

roughly leveled before placing and bolting strips. As shown on the plans, reinforcing strips shall be placed normal to the face of the wall. The maximum lift thickness shall not exceed 203 mm (8 inches) (loose) and shall closely follow panel erection. This lift thickness shall be decreased if necessary to obtain the specified compaction.

Backfill shall be compacted to 95 percent of the maximum density as determined by KM 64-511. A method of compaction consisting of at least 4 passes by a vibratory roller weighing at least 4.5 metric tons (5 tons) shall be used. For applications where spread footings are used to support bridge or other structural loads, the top 1.52 m (5.0 feet) below the footing elevation shall be compacted to 100 percent of the maximum density.

The moisture content of the backfill material prior to and during compaction shall be uniformly distributed throughout each layer. Backfill materials shall have a placement moisture content less than or equal to the optimum moisture content. Backfill material with a placement moisture content in excess of the optimum moisture content shall be removed and reworked until the moisture content is uniformly acceptable throughout the entire lift.

Compaction within 0.91 m (three feet) of the back face of the wall shall be achieved by at least three passes of a lightweight mechanical tamper, roller, or vibratory system.

At the end of each day's operation the Contractor shall slope the last level of the backfill away from the wall facing to rapidly direct runoff away from the wall face. In addition, the Contractor shall not allow surface runoff from adjacent areas to enter the wall construction site.

Geotextile fabric shall be installed as specified in Section II.J herein.

Vertical tolerances and horizontal alignment tolerance shall not exceed 19 mm (3/4 inch) when measured along a 3.05 m (10-foot) straight edge. The maximum allowable offset in any panel joint shall be 19 mm (3/4 inch). The overall vertical tolerance of the wall (plumbness from top to bottom) shall not exceed 4 mm in one meter (1/2 inch per 10 feet) of wall height.

Any wall materials which become damaged

or disturbed during backfill placement shall be either removed and replaced or corrected as directed or approved by the Engineer, at the Contractors' expense. Any misalignment or distortion of the wall facing panels due to placement of backfill outside the limits of this specification shall be corrected as directed or approved by the Engineer.

(6) **Retained Earth.** The foundation for the structure shall be graded level for a width equal to or exceeding the length of mesh reinforcement panels or as shown on the plans. Prior to wall construction, the foundation shall be compacted with a smooth wheel vibratory roller. Any foundation soils found to be unsuitable shall be removed and replaced.

Concrete facing panels should be placed in successive horizontal lifts in the sequence shown on the plans or approved shop drawings as backfill placement proceeds. As granular fill material is placed behind a panel, the panels should be maintained in vertical position by means of temporary wooden wedges placed in the horizontal joint at the junction of the two adjacent panels on the external side of the wall. External bracing is required for the initial lift.

Backfill placement shall closely follow the erection of each lift of panels. At each mesh level, backfill should be compacted and roughly leveled before placing mesh reinforcing panels. As shown on the plans, reinforcement shall be placed normal to the face of the wall. The maximum lift thickness shall not exceed 203 mm (8 inches) (loose) and shall closely follow panel erection. This lift thickness shall be decreased if necessary to obtain the specified compaction.

Backfill shall be compacted to 95 percent of the maximum density as determined by KM 64-511. A method of compaction consisting of at least 4 passes by a vibratory roller weighing at least 4.5 metric tons (5 tons) shall be used. For applications where spread footings are used to support bridge or other structural loads, the top 1.52 m (5.0 feet) below the footing elevation should be compacted to 100 percent of the optimum density.

The moisture content of the backfill material prior to and during compaction shall be

uniformly distributed throughout each layer. Backfill materials shall have a placement moisture content less than or equal to the optimum moisture content. Backfill material with a placement moisture content in excess of the optimum moisture content shall be removed and reworked until the moisture content is uniformly acceptable throughout the entire lift.

Compaction within 0.91 m (3 feet) of the back face of the wall shall be achieved by at least three passes of a lightweight mechanical tamper, roller, or vibratory system.

At the end of each day's operation the Contractor shall slope the last level of the backfill away from the wall facing to rapidly direct runoff away from the wall face. In addition, the Contractor shall not allow surface runoff from adjacent areas to enter the wall construction site.

Geotextile fabric shall be installed as specified in Section II.J herein.

Vertical tolerances and horizontal alignment tolerance shall not exceed 19 mm (3/4 inch) when measured along a 3.05m, (10-foot) straight edge. The maximum allowable offset in any panel joint shall be 19 mm (3/4 inch). The overall vertical tolerance of the wall (plumbness from top to bottom) shall not exceed 4 mm in one meter (1/2 inch per 10 feet) of wall height.

Any wall materials which become damaged or disturbed during backfill placement shall be either removed and replaced or corrected as directed or approved by the Engineer, at the Contractor's expense. Any misalignment or distortion of the wall facing panels due to placement of backfill outside the limits of this specification shall be corrected as directed or approved by the Engineer.

IV. METHOD OF MEASUREMENT

The quantity will be the gross area in square meters (square feet), not including footings or leveling pads for precast walls, lying in a plane of the outside front face of the structure as shown on the plans or as directed in writing. Portions or all of the footings for cast-in-place walls may be included in the gross area as shown on the plans. No field measurement will be made; the final quantity will be

the design quantity increased or decreased by authorized changes.

Structure excavation and backfill, foundation preparation, concrete footings or leveling pads for precast walls and portions of the footings for cast-in-place walls outside of the approved gross area, granular backfill, and geotextile fabric required as specified herein or due to the Contractor's choice of granular fill materials will not be measured for separate payment, but will be considered incidental to the cast-in-place or precast retaining wall.

Coping, trim, or similar items that are normal parts of precast wall construction will not be measured for payment but will be considered incidental to the precast retaining wall. Items such as concrete barriers that are not a part of normal retaining wall construction will be measured for separate payment, unless otherwise specified elsewhere in the contract. When concrete barriers are constructed on top of retaining walls, the bottom of the barrier for payment purposes will be a line 813 mm (32 inches) below, and parallel to, the top of the barrier.

Granular fill placed inside Doublewal or Evergreen modular units will be considered incidental, and will not be measured for separate payment.

V. BASIS OF PAYMENT

The accepted quantities of cast-in-place concrete retaining wall will be paid for at the contract unit price per square meter (square foot). The accepted quantities of precast concrete retaining wall will be paid for at the contract unit price per square meter (square foot). This payment shall be full compensation for all labor, equipment, materials, and incidentals necessary to acceptably fabricate, excavate, construct, and backfill the retaining wall in accordance with all requirements of this Special Provision and the contract. Payment will be made under:

<i>Pay Item</i>	<i>Pay Unit</i>
Retaining Wall	Square Meter or Square Foot

APPROVED Signature on File 4/1/91

J. M. YOWELL, P.E. DATE
STATE HIGHWAY ENGINEER

SPECIAL NOTE FOR T-WALL™

I. DESCRIPTION

The following requirements are hereby added to the current Special Provision No. 66, Concrete Retaining Walls, to allow, at the Contractor's option, the use of T-Wall™, as sold by the Neel Company 6520 Deepford Street, Springfield, VA 22150

II. MATERIALS FOR T-WALL

(1) **Precast Units.** Concrete for the precast units shall attain a minimum compressive strength of 27.58 MPa (4,000 psi) at or before 28 days. The concrete shall be air entrained containing 5.5 ± 1.5 percent entrained air at the time concrete is placed in the forms.

A proposed mix design shall be submitted as specified in Section 605.

(2) **Reinforcing Bars.** Reinforcing bars shall be grade 400 (60) and shall conform to ASTM A 615, A 616 or A 617, except No. 3 stirrups may be grade 300 (40). Welded steel wire mesh shall conform to ASTM A 185.

(3) Joint Materials

(a) Expansion Joint Fillers conforming to ASTM D 1752 shall be used in horizontal joints.

(b) All joints between panels shall be covered on the back side of the wall with geotextile fabric. The fabric shall be 305 mm (12 inches) wide and meet the requirements of Section 845, Table I.

(c) All joint materials shall be furnished by the T-WALL™ supplier.

(4) **Tolerances.** All units shall be manufactured within the following tolerances:

Face of unit, length or height: ± 4.8 mm (3/16 inch)

Deviation from square measured on diagonal: ± 7.9 mm (5/16 inch)

(5) **Forms.** Forms for the units shall be constructed of steel in a manner that will assure the production of uniform units, and shall remain in place until they can be removed without damage to the unit.

(6) **Mixing and Placing Concrete.** The concrete mix as designed shall be proportioned and mixed in a batch mixer to produce a homogeneous concrete conforming to the requirements. The transporting, placing, and compacting of concrete shall be by methods that will prevent segregation of the concrete materials and the displacement of the steel reinforcement from its proper position in the form. Concrete shall be carefully placed in the forms and vibrated sufficiently to produce a surface free from imperfections such as honeycomb, segregation, or cracking. Clear form oil of the same manufacture shall be used throughout the casting operation.

(7) **Curing.** The units shall be properly cured for a sufficient time so that the concrete will develop the specified compressive strength.

(8) **Testing and Inspection.** Acceptability of the precast units will be determined on the basis of entrained air in the concrete mixture, compression tests, and visual inspection. The Contractor or his supplier shall furnish facilities and the Certified Concrete Technician shall perform all necessary sampling and testing in an expeditious and satisfactory manner. Acceptance will be as specified in paragraph II. N. herein.

(9) **Finish.** Concrete surface shall be ordinary surface finish unless otherwise shown on the plans.

(10) **Marking.** The date of manufacture shall be clearly scribed or painted with waterproof paint on an interior surface of each unit.

(11) **Handling, Storing, and Shipping.** All units shall be handled, stored, and shipped in such manner as to eliminate the danger of chipping, cracks, fractures and excessive bending stresses.

(12) **Granular Fill Materials For T-Wall.** All fill material placed between the T-Wall stems shall meet requirements of Paragraph II. J. herein except that it need not comply with the requirements for resistivity, pH, chlorides, or sulphates.

III. CONSTRUCTION REQUIREMENTS FOR T-WALL

Wall Erection. The foundation for the structure shall be graded level for a width equal to the length of the stem. Prior to wall construction the foundation shall be compacted as shown on the plans or as directed by the Engineer. Any foundation soils found to be unsuitable shall be removed and replaced.

Form and pour the leveling pad. Tolerance for the leveling pad is ± 6.4 millimeters in 3.05 meters (1/4 inch in 10 feet). Begin placement of units by snapping a chalk line on the leveling pad at the front face of the wall. The vertical joint opening is 6.4 mm (1/4 inch). The vertical joint is backed with a 305 mm (12-inch) wide strip of geotextile. A fiber board joint material goes in the horizontal joint. Construct the wall in horizontal lifts. Backfill and compact each lift of units before starting the subsequent lift. Follow the manufacturers construction procedures.

Backfill between the stems shall be compacted to 95 percent of maximum density as determined by KM 64-511. Backfill around the outside of the wall, as shown on the plans or as directed by the Engineer, shall be placed and compacted in accordance with the project requirements for embankment.

Vertical tolerances and horizontal alignment tolerance shall not exceed 19 mm (3/4 inch) when measured along a 3.05 m (10-foot) straight edge. The maximum allowable offset in any unit joint shall be 19 mm (3/4 inch). The overall vertical tolerance of the wall (plumbness from top to bottom) shall not exceed 12.7 millimeters in 3.05 meters (1/2 inch per 10 feet) of wall height.

When erecting a battered wall, placement of backfill behind the wall shall closely follow erection of successive layers of units. At no time shall the difference in elevation between the backfill and the top of the last erected course exceed 1.83 m (6 feet).

Any wall materials which are damaged or disturbed during backfill placement shall be either removed and replaced or corrected, as directed or approved by the Engineer, at the Contractor's expense.

October 13, 1992

SPECIAL NOTE FOR STRENGTHENED EARTH WALLS™

I. DESCRIPTION

The following requirements are hereby added to the current Special Provision No. 66L, Concrete Retaining Walls, to allow, at the Contractors option, the use of Strengthened Earth Walls™ as sold by Gifford-Hill & Company, Concrete Products Division, 2515 McKinney Avenue, Dallas, TX 75201. Section references herein are to the current edition of the Kentucky Standard Specifications for Road and Bridge Construction.

II. MATERIALS FOR STRENGTHENED EARTH WALL

A. **Concrete Facing Panels.** Cement shall be Types I, II, or III and shall conform to the requirements of ASTM C 150. Air entraining, retarding or accelerating agents, or any additive containing chloride shall not be used without approval of the Engineer.

Connectors, pipe, and lifting devices shall be set in place to the dimensions and tolerances shown on the plans prior to casting.

(1) *Testing and Inspection.* Acceptability of the precast units will be determined on the basis of entrained air in the concrete, compressive strength tests and visual inspection. The Contractor, or his supplier, shall furnish facilities and the Certified Concrete Technician shall perform all necessary sampling and testing in an expeditious and satisfactory manner. A proposed mix design shall be submitted as specified in Section 605. Acceptance will be as specified in the current edition of Special Provision No. 66L, Paragraph II N.

(2) *Casting.* The panels shall be cast on a flat area: the front face of the form at the bottom, the back face at the upper part. Connectors shall be set in the back face. The concrete in each unit shall be placed without interruption and shall be consolidated by the use of an approved vibrator, supplemented by such hand-tamping as may be necessary to force the concrete into the corners of the forms and prevent the formation of stone pockets or cleavage planes. Clear form oil of the same manufacturer shall be used throughout the casting operation.

(3) *Forms.* Forms for panels shall be constructed of steel in a manner that will assure the production of uniform panels and shall remain in place until they can be removed without damage to the assemble precast wall unit.

(4) *Curing and Forms Removal.* Curing and forms removal will be as approved by the Division of Materials based on review of actual concreting, curing, and handling procedures proposed by the fabricator. In absence of any review, the requirements of Sections 605.06 and 605.07 of the Kentucky Standard Specifications for Road and Bridge Construction, shall apply

(5) *Concrete Finish.* Unless otherwise indicated on the plans or elsewhere in the specifications, concrete surface for the front face shall have a normal concrete finish, and for the rear face an unformed surface finish. Rear face of the panel shall be roughly screened to eliminate open pockets of aggregate and surface distortions in excess of 6.35 mm (1/4 inch).

B. Reinforcing Mesh and Tie Bars. Reinforcing mesh and tie bars shall be prefabricated from smooth bars meeting the requirements of ASTM A-82 and A-185 and galvanized in accordance with ASTM A-123. The mesh shall be cut to lengths shown on the plans or on the shop drawings.

All reinforcing mesh and tie bars shall be carefully inspected to ensure they are true to size and free from defects that may impair their strength and durability.

C. Connectors. Connectors shall be shop fabricated from cold drawn steel wire conforming to the requirements of ASTM A-82 and galvanized in accordance with ASTM A-123.

D. Joint Materials

(1) *Bearing Pads.* Bearing pads shall be a type and grade approved by Gifford-Hill & Company.

(2) *Joint Cover.* Where required, as shown on the plans, cover for horizontal and vertical joints between panels shall be a filter fabric as supplied by Gifford-Hill & Company. Adhesive used to temporarily attach the fabric material to the rear of the facing panels shall be approved by Gifford-Hill & Company.

III. CONSTRUCTION REQUIREMENTS FOR STRENGTHENED EARTH WALLS

A. Wall Excavation. Unclassified excavation shall be in accordance with the requirements of general specifications and in reasonably close conformity with the limits and construction stages shown on the plans.

B. Foundation Preparation. The foundation for the structure shall be graded level for a width equal to or exceeding the length of the reinforcing mesh, or as shown on the plans. Prior to wall construction, the foundation shall be compacted at least 4 passes by a 7.256-metric ton (8-ton) smooth wheel roller as directed by the Engineer. Any foundation soils found to be unsuitable shall be removed and replaced with select granular backfill material, as directed by the Engineer, and shall be incidental to the bid item Retaining Wall.

At each panel foundation level, an unreinforced cast-in-place concrete leveling pad shall be provided as shown on the plans. The concrete shall be Class A Concrete with compressive strength of 20.68 MPa (3,000 psi) 28-day strength. The leveling pad shall be cured a minimum of 24 hours before placement of wall panels.

C. Wall Erection. Precast concrete panels shall be placed "such that a final vertical face will be obtained" with the aid of a light crane. For erection, panels are handled by means of a lifting device set into the upper edge of the panels. Panels should be placed in successive horizontal lifts in the sequence shown on the plans as backfill placement proceeds. As backfill material is placed behind the panels, the panels shall be maintained in vertical position by means of temporary wooden wedges placed in the joint at the junction of the two adjacent panels on the external side of the wall. External bracing is required for the initial lift. Vertical tolerances (plumbness) and horizontal alignment tolerances shall not exceed 19 mm (3/4 inch) when measured with a 3.05-meter (10-foot) straight edge. The maximum allowable offset in any panel joint shall be 19 mm (3/4 inch). The overall vertical tolerance of the wall (plumbness from top to bottom) shall not exceed 25.4 millimeters per 3.05 meters (1 inch per 10 feet) of wall height.

Reinforcing mesh shall be placed normal to the face of the wall, unless otherwise shown on the plans or directed by the Engineer. Prior to placement of the reinforcing mesh, backfill shall be compacted in accordance with Section D, Backfill Placement.

(6) *Tolerances.* All units shall be manufactured within the following tolerances:

a. Panel Dimensions — All dimensions within 4.76 mm (3/16 inch).

b. Panel Squareness — Squareness, as determined by the difference between the two diagonals, shall not exceed 12.7 mm (1/2 inch).

c. Panel Surface Finish — Surface defects on smooth formed surfaces, measured on a length of 1.52 m (5 feet), shall not exceed 3.18 mm (1/8 inch). Surface defects on textured finished surfaces, measured on a length of 1.52 m (5 feet), shall not exceed 7.94 mm (5/16 inch). Rear face of the panel shall be roughly screened to eliminate open pockets of aggregate and surface distortions in excess of 6.35 mm (1/4 inch).

(7) *Compressive Strength.* Acceptance of the concrete panels, with respect to compressive strength, will be determined on the basis of production lots. A production lot is defined as a group of panels that will consist of either 80 panels or a single day's production, whichever is less.

Acceptance of a production lot will be made if the compressive strength test result is greater than or equal to 27.58 MPa (4,000 psi) at or prior to 28 days.

In the event that a production lot fails to meet the specified compressive strength requirements, the production lot shall be rejected. Such rejection shall prevail unless the manufacturer, at his own expense, obtains and submits cores for testing and the results show that the strength and quality of the concrete placed within the panels of the production lot is acceptable. The cores shall be taken from the panels within the production lot and tested in accordance with the specifications of ASTM C 42 and KM 64-317. Two cores per each cylinder which failed will be required.

(8) *Rejection.* Units shall be subject to rejection because of failure to meet any of the requirements specified above. In addition, any or all of the following defects may be sufficient cause for rejection:

a. Defects that indicate imperfect molding.

b. Defects indicating honeycombed or open texture concrete.

c. Defects in the physical characteristics of the concrete, such as broken, cracked, or chipped concrete.

The Engineer shall determine whether spalled, honeycombed, chipped or otherwise defective concrete shall be repaired or be cause for rejection. Repair of concrete, if allowed, shall be done with an epoxy mortar approved by the Department in a manner satisfactory to the Engineer. Repair to concrete surfaces which will be exposed to view after completion of construction must be approved by the Engineer.

(9) *Marking.* The date of manufacture, the production lot number, and the piece-mark shall be clearly scribed on the rear face of each panel.

(10) *Handling, Storage and Shipping.* All units shall be handled, stored and shipped in such a manner as to eliminate the danger of chipping, cracks, fractures and excessive bending stresses. Panels in storage shall be supported on firm blocking located immediately adjacent to connectors to avoid their bending.

D. Backfill Placement. Backfill placement shall closely follow erection of each course of panels. Backfill shall be placed in such a manner as to avoid any damage or disturbance to the wall materials or misalignment of the facing panels. Any wall materials which become damaged or disturbed during backfill placement shall be either removed and replaced at the Contractor's expense or corrected, as directed by the Engineer. Any misalignment or distortion of the wall facing panels due to placement of backfill outside the limits of this specification shall be corrected, as directed by the Engineer.

Backfill shall be compacted to 95 percent of the maximum density as determined by KM 64-511. A method of compaction consisting of at least 4 passes by vibratory roller weighing at least 4.53 metric tons (5 tons) shall be used.

The moisture content of the backfill material prior to and during compaction shall be uniformly distributed throughout each layer. Backfill materials shall have a placement moisture content less than or equal to the optimum moisture content. Backfill material with a placement moisture content in excess of the optimum moisture content shall be removed and reworked until the moisture content is uniformly acceptable throughout the entire lift. The optimum moisture content shall be determined in accordance with AASHTO T-99 Method C or D (with oversize correction, as outlined in Note 7).

The maximum loose lift thickness shall not exceed 203 mm (8 inches). The Contractor shall decrease this lift thickness, if necessary, to obtain the specified density. Compaction within .91 meters (3 feet) of the backface of the wall facing shall be achieved by at least 3 passes of a lightweight mechanical tamper, roller or vibratory system.

At the end of each day's operation, the Contractor shall slope the last level of backfill away from the wall facing to rapidly direct runoff of rainwater away from the wall face. In addition, the Contractor shall not allow surface runoff from adjacent areas to enter the wall construction site.

August 24, 1994

**KENTUCKY TRANSPORTATION CABINET
DEPARTMENT OF HIGHWAYS
SPECIAL PROVISION NO. 69G (94)
EMBANKMENT AT BRIDGE END BENT STRUCTURES**

This Special Provision shall apply when indicated on the plans or in the proposal. Section references herein are to the Department's 1994 Standard Specifications for Road and Bridge Construction.

I. DESCRIPTION

This work shall consist of construction of an earth core and granular embankment at end bent structures. The earth core and granular embankment shall be constructed in accordance with the requirements of this Special Provision, the plans, standard drawings, and the 1994 Standard Specifications. Construction shall be in accordance with Structure Granular Backfill and Roadway Fill-Granular Embankment, as required by the plans.

II. MATERIALS

A. Earth Core. Unless otherwise provided material for the earth core shall meet all requirements of the Standard Specifications for embankment materials and, in addition, shall be free of boulders larger than 64 mm (2 1/2 inches) maximum dimension or any other obstructions which would interfere with the driving of piles. Roadway Fill-Granular Embankment material will be permitted, provided the 64-mm (2 1/2-inch) maximum dimension is not exceeded.

When the plans specify that the core shall be constructed of Roadway Fill-Granular Embankment material, then 100% of the material placed within the limits of the core shall not exceed the 64-mm (2 1/2-inch) maximum dimension.

B. Roadway Fill-Granular Embankment

(1) Requirements.

(a) Roadway Excavation. When granular embankment is specified to be obtained from roadway excavation as noted on the plans, acceptance will

outside the limits of granular embankment will be in accordance with requirements elsewhere in the contract.

V. BASIS OF PAYMENT

The accepted quantities measured as specified herein will be paid for at the contract unit prices, which payment shall be full compensation for all work and materials necessary to complete the earth core, granular embankments, structure excavation for the end bent, and granular backfill as specified herein, on the plans and standard drawings, and in the Standard Specifications.

Payment will be made under:

Pay Item	Pay Unit
Roadway Excavation	See Section 204.12
Embankment-in-Place	See Section 207.10
Borrow Excavation	See Section 205.04
Structure Granular Backfill	Cubic Meter or Cubic Yard
Roadway Fill-Granular Embankment	Cubic Meter or Cubic Yard

APPROVED Signature on File 4/1/94
J. M. YOWELL, P.E. DATE
STATE HIGHWAY ENGINEER

of material for the earth core or for any necessary manipulation such as stockpiling or double hauling.

B. Roadway Fill - Granular Embankment. The quantity of Roadway Fill-Granular Embankment complete and accepted in the final work will be measured in cubic yards. The final pay quantity will be the design quantity, increased or decreased by authorized adjustments as specified in subsections 204.11.01 and 204.11.02. The volume of the earth core will be deducted from the pay quantity of Roadway Fill-Granular Embankment.

C. Structure Granular Backfill. The quantity of structure granular backfill complete and accepted in the final work will be measured in cubic yards. The final pay quantity will be the design quantity, increased or decreased by authorized adjustments as specified in subsections 204.11.01 and 204.11.02. Any additional material required for backfill outside the limits shown on the plans and standard drawings will not be measured for payment.

D. Incidental Items. When construction sequence "A" as shown on the standard drawings is followed, structure excavation at the end bent will be considered incidental to Structure Granular Backfill.

Furnishing and placing the 51-mm (2-inch) mortar or concrete bed is considered incidental to the end bent, and no separate measurement or payment will be made.

The 102-mm (4-inch) perforated underdrain pipe for draining structure granular backfill will be considered incidental to the backfill.

Two hundred three-millimeter (8-inch) perforated pipe and headwalls placed due to the use of erodible material will be considered incidental to the granular embankment.

When geotextile fabric is required due to the use of erodible or unstable material for granular embankment, furnishing and placing the fabric shall be incidental to the granular embankment and no separate measurement or payment will be made. This geotextile fabric shall be incidental regardless of whether the erodible or unstable material was specified or permitted.

When the plans require geotextile fabric to be placed outside the limits of granular embankment, then measurement and payment for the fabric

end bent may be placed as soon as the mortar has set sufficiently to support workmen and forms without being disturbed.

One hundred two-millimeter (4-inch) perforated pipe shall be installed in accordance with the plans. In the event slope protection extends above the elevation of the perforated pipe, the pipe shall be extended through the slope protection.

After the end bent cap has been placed and adjacent forms removed, the excavation shall be filled with granular backfill material to the level of the berm prior to placing beams for the bridge. After the end bent backwall has been completed, or after the span end wall has been completed, the granular backfill shall be placed to subgrade elevation. If the original excavation has been enlarged, the entire volume shall be filled with compacted granular backfill at no additional cost to the Department. In no case shall backfill be placed before removal of adjacent form work. Granular backfill material shall be placed in trench ditches at the ends of the excavation.

Individual fragments larger than 102-mm (4 inches) in any dimension shall not be permitted within 0.91 (3 feet) of the structure.

The backfill shall be tamped by hand tampers, pneumatic tampers, or other means approved by the Engineer. Care shall be exercised to thoroughly compact the backfill under the overhanging portions of the structure to ensure that the backfill is in intimate contact with the sides of the structure.

The earth core, granular embankment, and granular backfill, shall be placed and compacted in accordance with the requirements for density applicable to the project.

No seeding, sodding, or other vegetation shall be applied to the exposed granular embankment.

IV. METHOD OF MEASUREMENT

A. Earth Core. Material for the earth core will be measured as Roadway Excavation, Embankment-in-Place, or Borrow Excavation, as applicable. No separate measurement or payment will be made for overhaul

and the geotextile fabric shall be placed between the embankment and the specified slope protection.

All additional work or material required because erodible or unstable materials are used for granular embankment, including but not limited to geotextile fabric and the 203-mm (8-inch) perforated pipe and headwalls, shall be furnished at no additional cost to the Department.

C. Structure Granular Backfill. Structure granular backfill shall be coarse aggregate, crushed or uncrushed (including pea gravel), meeting the requirements of Section 805.03 with the additional requirement that the minus 75 μ m (No. 200) content does not exceed 5 percent when tested by KM 64-606. Gradation shall be uniform and shall meet the following requirements when tested by KM 64-602.

Sieve Size	Percent Passing
100 mm (4 inch)	100
4.75 mm (No. 4)	0-30

Acceptability of the minus 75 μ m (No. 200) portion may be based upon visual inspection by the Engineer when the material includes a significant amount of individual fragments greater than 38 mm (1 1/2 inches).

III. CONSTRUCTION REQUIREMENTS

Normal roadway embankments at end bents shall be constructed in accordance with Section 207 and in accordance with the plans and standard drawings for full embankment section. After the embankment has been constructed, excavating for the end bent cap, driving piling, placing mortar bed, constructing end bent, and completing the embankment to finish grade shall be in accordance with the construction sequence shown on the plans or standard drawings and as specified hereinafter.

After piles are driven (see design drawings), the bottom of the excavation shall be sloped toward ends of the trench as noted on the plans for drainage. A separate pour of concrete mortar, or any class concrete, shall be placed to provide a base for forming and placing the cap. Side forms for the

Crushed coarse aggregate (other than gravel) smaller than Size No. 57.

Any material with 50% or more passing the 4.75 mm (No. 4) sieve.

Sandstone will be judged to be friable or non-friable by the Engineer.

(3) *Special Construction Methods.* Erodible or unstable materials may erode even when protected by riprap or channel lining; the special construction methods as described below shall be employed when using these materials.

Fine Aggregates or friable sandstone may be used for granular embankment at "dry land" structures only, and will not be permitted at stream crossings or where likely to be subjected to flood waters.

When material having 50 percent or more passing the 4.75 mm (No. 4) sieve is used for embankment, 203-mm (8-inch) perforated underdrain pipe shall be installed at or near the elevation of the original ground in the approximate locations depicted on the standard drawing and as directed by the Engineer, so as to ensure positive drainage of the embankment. The 203-mm (8-inch) perforated pipe shall be wrapped with geotextile fabric of a type recommended by the pipe manufacturer. Headwalls will be required on the outlet end of each perforated pipe.

All granular embankment material described above as erodible or unstable, and having 50 percent or more passing the 4.75 mm (No. 4) sieve, shall be protected by geotextile fabric meeting the requirements of Table I in Section 845. Fabric shall be covered a minimum of one foot deep with non-erodible material. The fabric shall extend from original ground to the top of slope over the entire area of the embankment slopes on each side of, and in front of, the end bent.

For erodible or unstable materials having less than 50 percent passing a 4.75 mm (No. 4) sieve, the 0.30-meter (one-foot) protective cover shall be placed, but the geotextile fabric is not required.

Where erodible or unstable granular embankment will be protected by riprap or channel lining the 0.30 m (one-foot) cover will not be required,

be by visual inspection by the Engineer. Granular embankment shall be reasonably free of shale or other deleterious materials.

(b) *Off-site Materials.* Granular embankment shall have no more than 10 percent passing the 75 μ m (No. 200) sieve when tested by KM 64-606.

The quality of all granular embankment shall be acceptable to the Engineer. Shale shall not be permitted for use as granular embankment unless noted on the plans or proposal.

Acceptability of processed material may be based on visual inspection by the Engineer when the material includes a significant amount of individual fragments greater than 38 mm (1 1/2 inches).

(2) *Classification.* Granular embankment is classified as (a) non-erodible or (b) erodible or unstable. Special construction methods are required as specified in Section II.B(3) below when erodible or unstable materials are used.

(a) *Non-Erodible Materials.* The following materials are considered to be non-erodible:

Blasted Limestone/dolomite

Non-friable blasted sandstone

Limestone coarse aggregate Size No. 57 or larger.

Non-friable sandstone coarse aggregate Size No. 57 or larger.

(b) *Erodible or Unstable Materials.* The following materials are considered to be erodible or unstable:

Natural or manufactured fine aggregate

Friable sandstone

Crushed or Uncrushed gravel, any size

REINFORCED EARTH™ BRIDGE ABUTMENTS

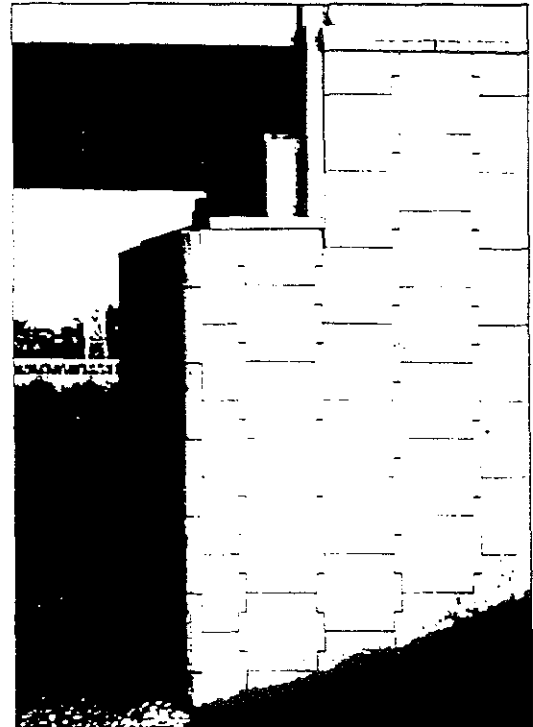
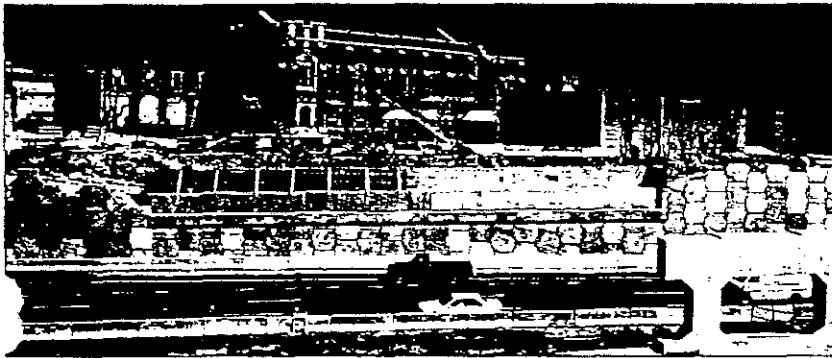
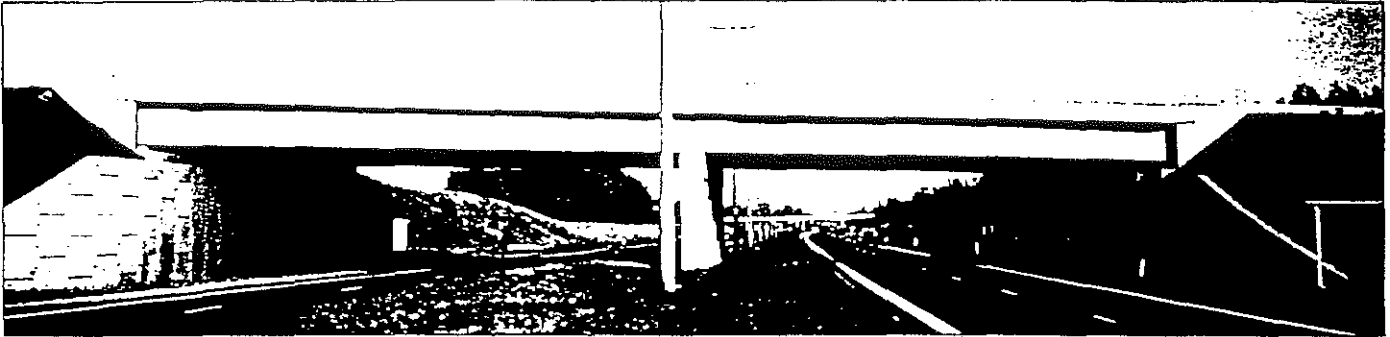

●●●●●
●●●●● reinforced earth
●●●●●

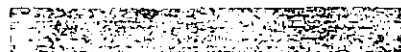

CONCLUSION

Reinforced Earth technology has made possible new and economical designs for bridge abutments adaptable to the widest variety

of superstructures and foundation soils. Complementing the performance of engineering techniques that have undergone more than 15 years of research and development are all

the advantages of quick and scaffold-free construction. The appearance can take many forms. Each year, over 120 bridges are built on Reinforced Earth abutments.

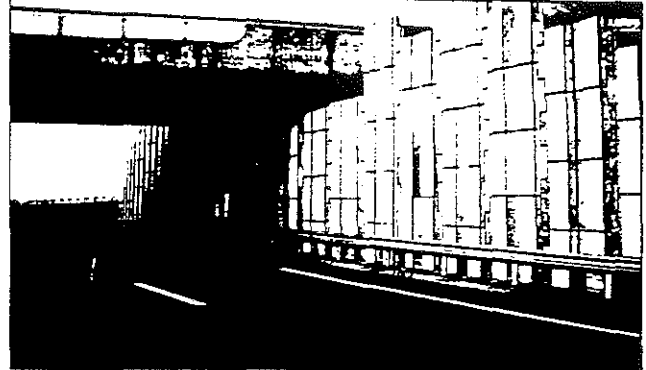
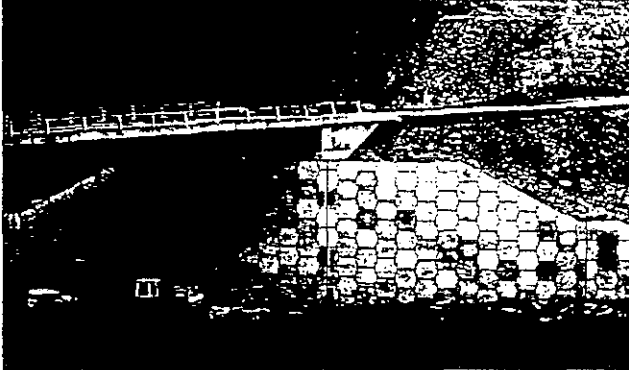

A WORLDWIDE ORGANIZATION

Licensed under the patents issued to Henri Vidal throughout the world, the Reinforced Earth Group of companies operates in 33 countries on six continents. Although part of the same Group, each company is independently managed by nationals of that country who are professional engineers that understand local conditions, codes of practice, and construction capabilities and techniques.

Research and other technological activities among the different companies are coordinated from Paris, France, by Terre Armée Internationale, parent company of the Group.

For new applications and special or unusual projects, Terre Armée Internationale can pool the resources of several companies to create optimum project designs and material specifications. It also acts as the central technical service organization, and maintains the primary information data base collected from new applications, special projects and research.

Terre Armée Internationale takes the lead in organizing and developing research projects, both under its own direction and through coordination among the other companies.

Analysis and synthesis of research and technical data by Terre Armée Internationale results in technical recommendations and design improvements published in routine reports disseminated to all the Reinforced Earth Group companies.

The dynamics of this organization allow each Reinforced Earth company to offer government agencies, owners, consultants and contractors the understanding and flexibility of a local business, combined with the vast resources and technological advantages of a global concern.



FRANCE • GERMANY • UNITED KINGDOM • ITALY • SPAIN • BELGIUM • THE NETHERLANDS • SWITZERLAND • PORTUGAL • IRELAND • UNITED STATES • CANADA • MEXICO • ARGENTINA • BRAZIL • VENEZUELA • AUSTRALIA • NEW ZEALAND • SOUTH AFRICA • JAPAN • MALAYSIA • SINGAPORE • BRUNEI • HONG KONG • SOUTH KOREA • THAILAND • TAIWAN • INDONESIA • IRAN • KUWAIT • OMAN • QATAR • LEBANON • SAUDI ARABIA

Pier Abutments

A disadvantage of mixed abutments with interior support is that the pilings must be placed relatively far behind the facing, thereby lengthening the bridge span. When the foundation soil is good, a special type of mixed abutment with interior supports, called a "pier abutment," makes it possible to set the supports closer to the facing (Fig. 39).

In these cases, concrete piles are poured directly into blockouts cast into specially made facing panels. At present, these special facing panels are prefabricated in two pieces and assembled at the site. These piles transmit the bridge loads through the reinforced volume to a footing below the structure. The piles are poured only after the Reinforced Earth structure has been completed and the embankment has been backfilled. The reinforcements will then be in tension and any deformations will have occurred.

After the concrete has been poured, the special panels are made integral with the concrete piles. That is why this type of structure is suitable only for sites with good foundation soils, where the flexibility of the facing is no longer indispensable once construction is complete. Subsequent settlement of the foundation would create the possibility of secondary stresses in the concrete piles through interaction with the reinforcements and the facing.

To accommodate horizontal stresses from the roadway without transmitting these stresses to the piling, additional reinforcements are either placed above the piles or attached directly to the cap beam. Since pier abutments are used only on good foundation soils, approach slabs are usually not required.

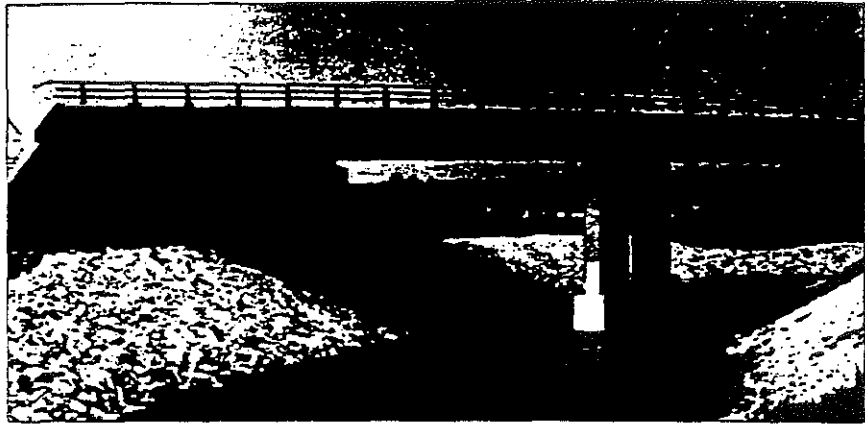

Pier abutment for the Tille Bridge. Dijon-Langres Freeway in France.

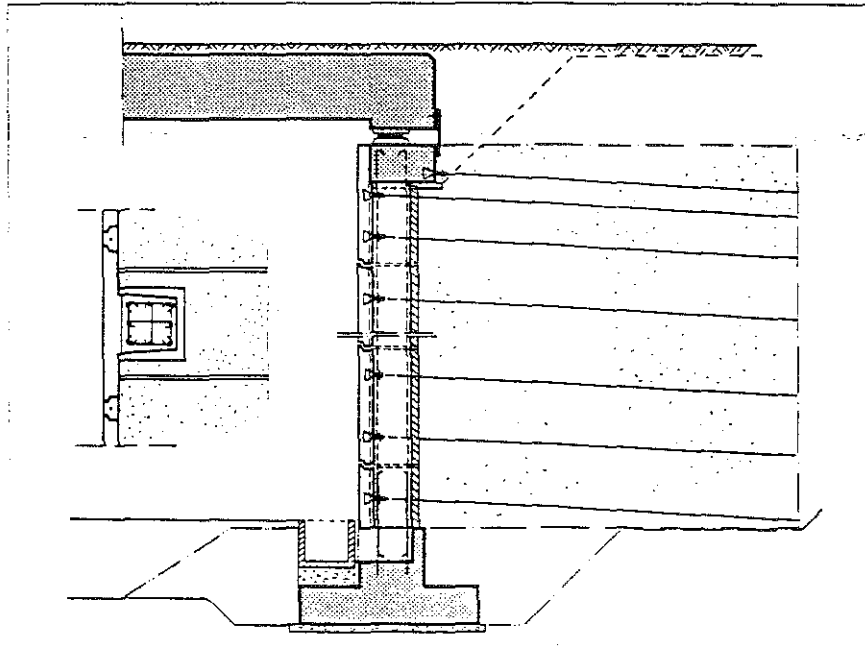

Figure 39: Diagram of a pier abutment.



Abutment pier under construction.



Special prefabricated panel.

There are certain cases in which a foundation soil that is too compressible for the proposed structure (e.g., a large continuous viaduct) cannot be sufficiently improved to result in acceptable limits of consolidation. In such cases, a mixed solution can be adopted in which the beam seat and bridge deck are supported by piling or other special foundations, and the embankment is retained by Reinforced Earth. This solution makes the support structures nearly independent of the embankments. Also, by building the Reinforced Earth structure in advance,

the amount of negative skin friction on the piling can be reduced. In the case of a mixed abutment where the bridge is no longer supported by the Reinforced Earth structure, a conventional approach slab is used as a transition.

Mixed Abutments with Exterior Supports

In these cases, piers are usually placed in front of the Reinforced Earth structure, either in the form of a row of columns topped by a cap beam, or as a full pier that runs along the face of the approach structure. This arrangement reduces the span of the bridge to a minimum and, in effect, separates the construction of the two parts of the project.

The distance to be maintained between the pilings (or pier) and the Reinforced Earth structure depends primarily on either the width of the foundation, or on the clearance required by the construction equipment. When the distance is small, the Reinforced Earth facing is connected to the cap beam or to the end wall of the beam seat (Fig. 38a). Clearances and overlaps are provided as needed, so that any possible

subsequent movement caused by consolidation of the foundation soil will not result in contact or loss of fill. When the distance is large, the transition slab assumes the form of a small connecting span over this area (Fig. 38b). All aspects of the connection require detailed study, particularly at the shoulders and edges of the embankment.

Mixed Abutments with Interior Supports

For aesthetic reasons, pilings are sometimes embedded within the Reinforced Earth structure. There are two instances where this is a customary practice. In the first, piles are driven prior to construction of the Reinforced Earth embankment, requiring that backfill be carefully placed and compacted around each column. In the second instance, piles are driven through the Reinforced Earth structure after the latter has been completed. In both cases, sleeves are used to separate the supports from the fill, leaving sufficient clearance to prevent any transmission of lateral load. The sleeves also make it possible to drive the piling without cutting or damaging the reinforcing strips.

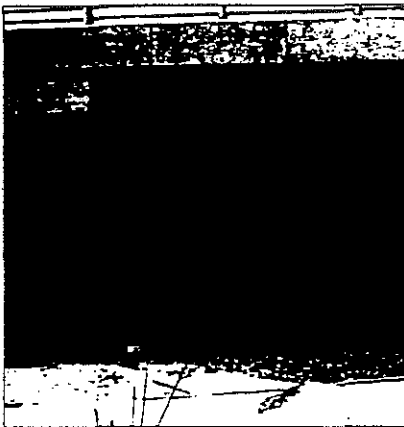

Combined abutment of the Epron Bridge. National Highway RN 57 Besançon-Epinal, France.

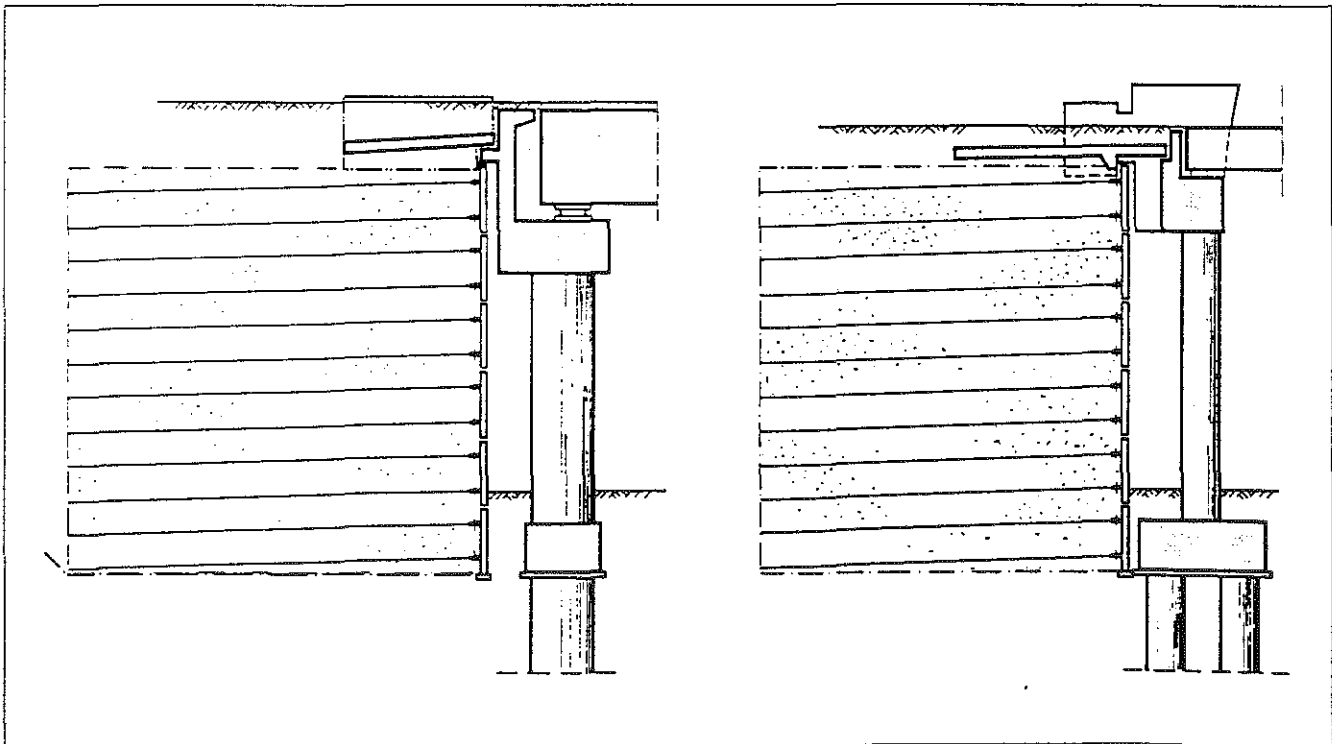

Figures 38a, 38b: Typical details of the connection between an exterior pier and the Reinforced Earth structure.



Preloading
Preloading is another classic method of improving foundation soil. Three types of preloading can be used in the construction of Reinforced Earth abutments on compressible soil.

Preloading Exerted by Reinforced Earth

This variant is used in cases such as those described above in which structures are built directly and without prior treatment. The site is preloaded by the Reinforced Earth embankment itself before the superstructure is set in place.

Preloading Using Ordinary Fill

The second, more traditional method involves preloading the site with an ordinary fill intended to remain in place only temporarily. This method is used when the surcharge must be put in place quickly, or when the levels of consolidation and settlement during this phase would exceed the permissible facing deformation level. This technique was used near Champlain in Canada for an overpass of highway A 40 (Fig. 37a). The 76-meter bridge, consisting of three independent spans, is supported by two Reinforced Earth abutments built on 24 meters of compressible clay. Because the anticipated level of settlement was 30 to 45cm, a temporary surcharge 6.4 meters thick was put in place two years before construction of the abutments. When the settlement level had reached 25cm the temporary surcharge was partially cleared away and replaced with Reinforced Earth structures. Five years after construction of the bridge, the



Rocquencourt bridge on the West Highway near Paris, France.

abutments had dropped about three centimeters, causing no problems.

Combined Preloading

A third method consists of precharging the site simultaneously with the final Reinforced Earth structure and a temporary topping of fill or concrete blocks. The topping is designed to stand in for part or all of the future superstructure's weight. Consolidation is thereby accelerated and, if the construction schedule permits, final levels of settlement and deformation of the Reinforced Earth abutment can be reached before the roadway is built. This method was used for a bridge in Rocquencourt, France, with concrete blocks providing the surcharge. The site consisted of eight to ten meters of uncompacted fill which consolidated quickly. On the Route One bridge over the Boston and Maine Railroad in the United States, built on 40 meters of relatively loose sand and wet clay of average consistency, 3.3 meters of additional fill were enough to produce one-third (22cm) of the anticipated long-term settlement (Fig. 37b). The flexible

nature of this independent metal span structure is expected to adapt well to the remaining settlement.

Whichever method is used for building Reinforced Earth abutments on compressible soils, the purpose should always be to optimize the use of Reinforced Earth's inherent flexibility. Additional measures are employed only when necessary.

Every Reinforced Earth structure built on compressible soil constitutes a new and unique project. In designing each project, company engineers take into account the nature of the superstructure, scheduling requirements and deadlines, geotechnical data, and the flexible possibilities of Reinforced Earth.

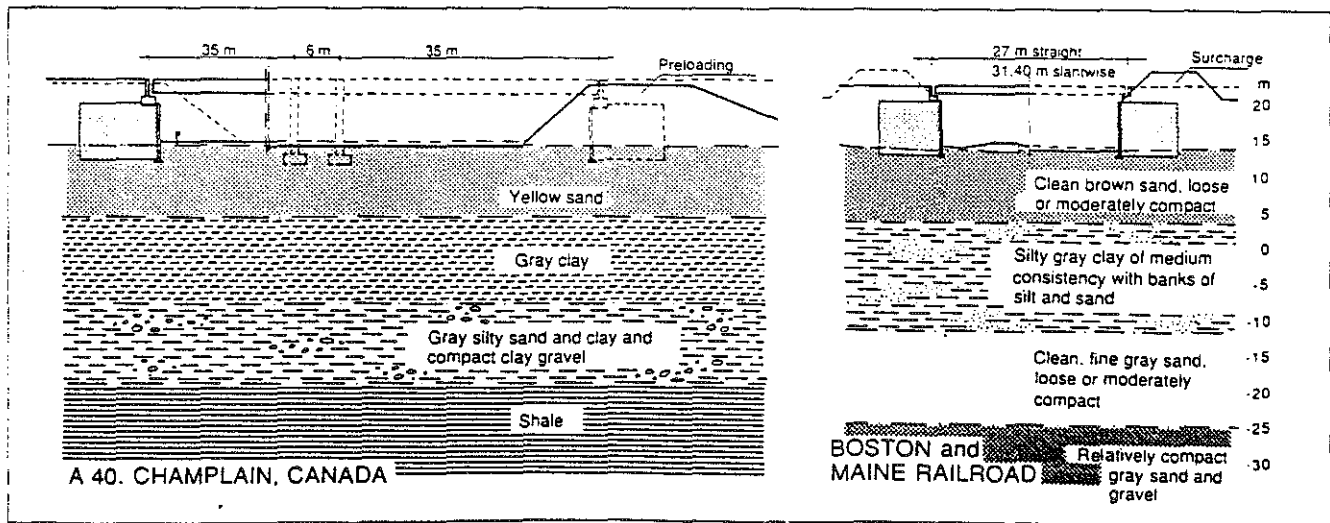

Figures 37a, 37b: Preloading for the Champlain and Boston and Maine railroad bridges.

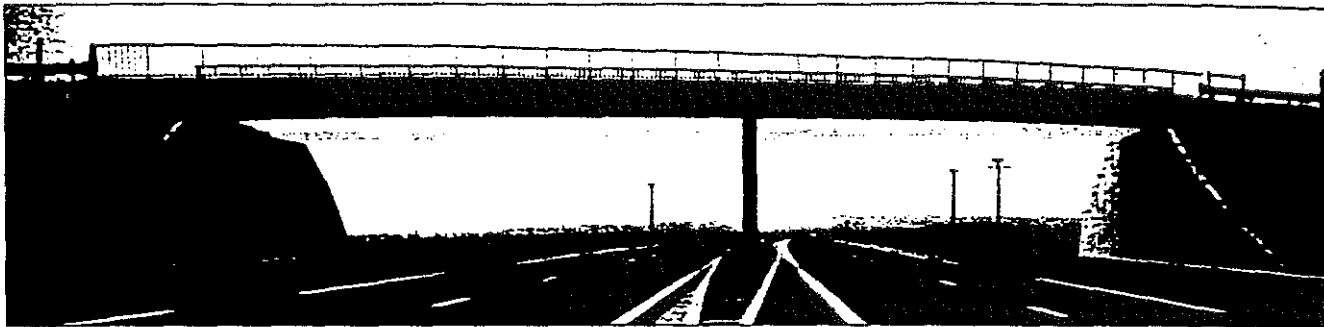

Overpass bridge on the Nancy-Dijon Freeway in France.

Special Procedures
 Where the bearing capacity of the soil does not allow for support of the total load imposed by the abutment, special procedures are required. In such cases, the danger exists for a deep slippage or a bearing capacity failure. Special measures are also called for when the anticipated amount of residual settlement under the abutments is incompatible with the longitudinal structure of the bridge, as is generally the case with multiple, continuous-span bridges. Nevertheless, certain flexible slab-bridges, like those forming the overpass bridges of the Dijon-Genève Highway in France, easily tolerate settlement levels of several centimeters at their end supports.

Special steps are also needed when the soil quality is so inconsistent that it creates a risk of causing unacceptable levels of residual differential settlement of the abutment perpendicular to the roadway, thereby throwing the supports out of level.

Certain measures are also required when the level of delayed settlement is exceptionally high and at the same time rather uncertain, or too slow to enable control of the project or its longitudinal profile.

Most often, the methods used where Reinforced Earth abutments are built on highly compressible soils involve ground improvement techniques to reduce foundation soil compressibility or preloading of the structures prior to superstructure installation in order to anticipate the deformations that will occur.

Soil Improvement Techniques

Substitution is by far the most common method used to improve foundation soil. This involves replacing the existing surface soil to the depth of a few meters—where the most compressible soil often lies—with a good, compacted fill.

An overpass section of the Ring de Kortrijk in Belgium was built on Reinforced Earth abutments at a site where the very thick Flanders clay had been covered with four meters of clayey hydraulic soil (Fig. 35). This layer, in which the peak resistance was as low as six bars, was replaced, resulting in a settlement level of only 50mm during construction of the abutments and 35mm after placement of the superstructure.

Under more exceptional circumstances, the foundation soil is reinforced ahead of time using a system of ballasted "stone columns" set in place by a large vibrator. For example, design of the Grossbliederstroff Bridge crossing the Saar River at the French-German border called for a 29-meter span supported on six-meter high

Reinforced Earth abutments (Fig. 36). In this case the superstructure is heavy relative to the weight of the abutments, so that most of the foundation soil settlement would ramify through the superstructure. Soil at the site consisted of about ten meters of clayey alluvial deposits of mixed quality, which could be expected to settle 15cm or more. In addition, the site did not offer adequate security against a major slide failure. By incorporating stone columns into the design—80cm in diameter, ten meters in depth and spaced every 1.5 meters—stability of the bridge structure was guaranteed, and settlement was limited to 5cm.

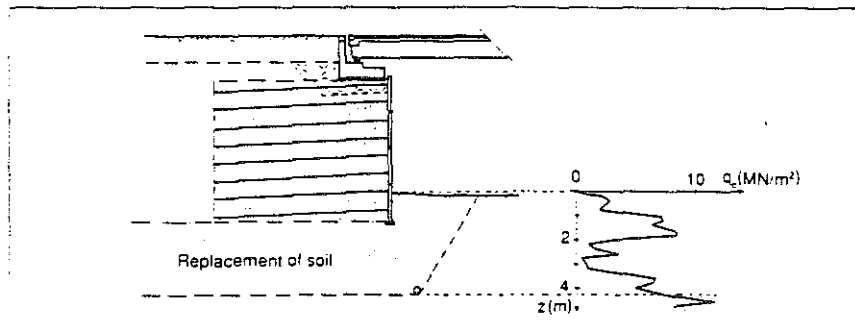

Figure 35: Replacement of soil under the abutments of the Kortrijk Bridge.

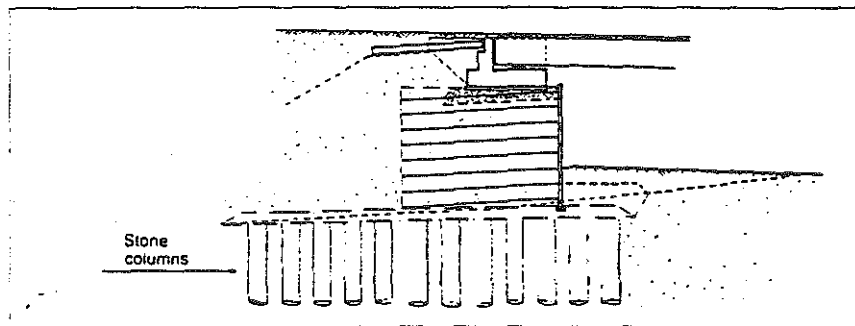

Figure 36: Stone columns under the abutments of the Grossbliederstroff Bridge.

In constructing Reinforced Earth bridge abutments, the compressibility of the foundation soil is first assessed relative to the bridge itself. Pertinent factors include the weight of the superstructure relative to the size of the abutments, the degree of rigidity of the structure, and the criticality of the scope of the project. Another important factor is the rate at which the soil will consolidate, considered in terms of the overall project schedule.

Under good conditions, abutments and the superstructure can be constructed together, without phasing the work or taking special meas-

ures to improve soil properties. However, an identical site with a different type of bridge may require special considerations and procedures. In effect, every project is unique.

Direct Construction

Light Bridges: Reinforced Earth abutments distribute loads exerted by the bridge. Therefore, when an abutment is high relative to the length of the span, as at Val d'Esnoms in France, pressure on the foundation is derived primarily from the weight of the backfill. If a sufficient period of time is allowed for the settlement and consolidation of the foundation due to

the weight of the Reinforced Earth mass prior to placement of the beam seat and superstructure, only the Reinforced Earth structure and its facing will be affected. Both the structure and its facing have a relatively high tolerance for such deformation.

At Vallon des Acacias in Nice, abutments 17 meters high were built askew to an old river channel filled with compressible alluvial deposits. These abutments settled 40 to 70cm and experienced 1.5 percent differential settlement without damage. The 9.5 meter roadway spans were installed several months later and exhibited no significant movement.

Ordinary bridges: Many other structures of more common dimensions—where the weight of the superstructure is relatively greater—are built in the same way. For single-span structures, residual settlement levels of several centimeters are generally allowable.

The structure built at Antoing, Belgium, is a typical example. The foundation soil, made up of five meters of loose, clayey sand, quickly settled 65mm under the weight of the Reinforced Earth structures (180 kPa) (Fig. 34). In the second phase, construction of the superstructure increased the loading on the foundation by a little more than a third, and caused additional, very homogeneous settlement of 25mm. This was the only settlement to affect the superstructure. The record of settlement that occurred prior to installation of the superstructure made it possible to refine the estimate of final settlement levels, and to use this estimate in designing the supports. Such refined estimates are usually one of the major advantages of this method of phased construction.

Bridges built in this manner on Reinforced Earth abutments, taken together with structures built on good soils, make up about 90 percent of all projects.



Val d'Esnoms. Nancy-Dijon Freeway in France.



Vallon des Acacias. Côte d'Azur Freeway in France.

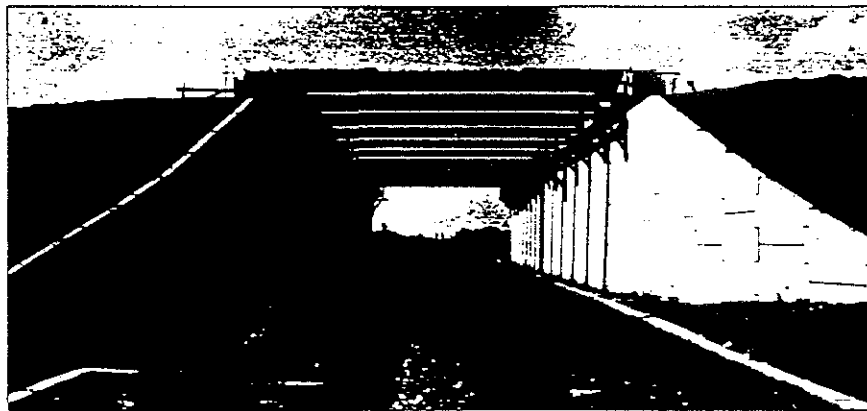

Antoing Bridge.

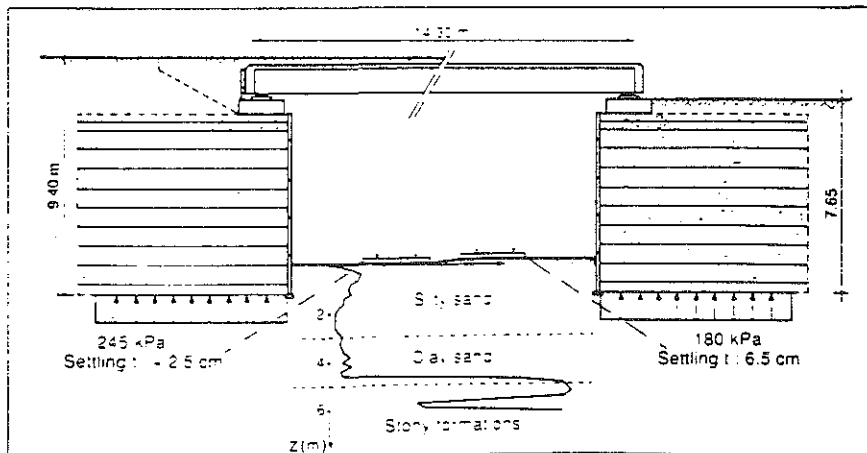

Figure 34. Antoing Bridge. Consolidation of foundation soil.

B

efore examining how Reinforced Earth abutments make it possible to accommodate settlement of the foundation soils, precaution must be taken to minimize deformations in the structure itself following placement of the superstructure and its resulting movements within the beam seat.

Differential settlement of the beam seat, accompanied by rotation, could result in damaging distortion of the bearing pads and the expansion joint. However, there is no danger of this condition occurring if the fill has been properly compacted.

As previously discussed, when the Reinforced Earth volume has been properly compacted, the amount of settlement under the beam seat usually will not exceed a few millimeters under normal design situations.

Compaction and Selection of Backfill

In order to limit the amount of settlement in an abutment to negligible levels, it is necessary to follow precisely the standard specifications for the selection, placement, and compaction of backfill materials used in the construction of embankments built beneath roadbeds.

Without going into unnecessary detail regarding these specifications, it should be noted that water-sensitive backfill materials must not be placed during rainy weather, or used if they are excessively wet when delivered. Conversely, provided they are not rejected in the first place, if these materials are too dry they must be moistened as needed and vigorously compacted.

In the area immediately behind the facing and directly beneath the beam

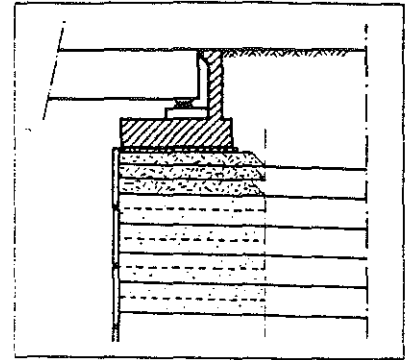

Figure 32: Layers of materials selected and compacted under the beam seat.

seat, where only lighter compaction equipment can be used, it is recommended that smaller backfill lift thickness be specified. In addition, the use of subgrade-type backfill, which provides the additional advantage of good drainage, is advisable as a distribution layer beneath the beam seat (Fig. 32).

Drainage

It is imperative that special care be taken in the collection and removal of water that can penetrate the expansion joint or filters at the point of contact between the embankment and the backwall or roadway. Water must be prevented from seeping under the beam seat, where it could cause settlement or subsidence after saturation, or leach and wash away fines.

Therefore, the beam seat design must include the necessary slopes and gutters. In some cases drains must be installed (Fig. 33). The design and proper maintenance of drainage outlets must always be provided. Ideally, outlets should be located outside the structure, easily accessible for maintenance purposes.

Protection against water is also very important during each phase of construction, particularly during the phase when the bridge deck has been placed on the beam seat, but neither the approach embankment nor the surface drainage system have been constructed.

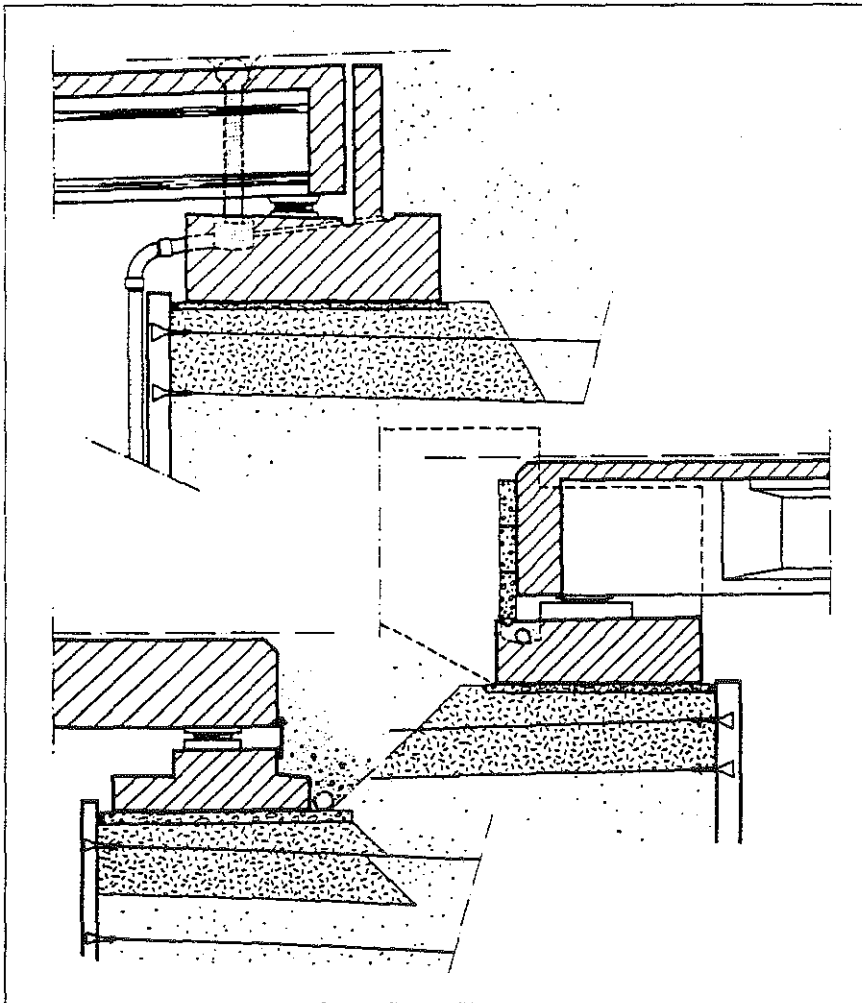

Figure 33: Typical drainage details.

Width of the Beam Seat
 Generally, reinforced concrete beam seats are dimensioned so that the contact pressure imparted to the Reinforced Earth mass will be as uniform as possible and will be less than 150 kPa under permanent loading conditions. Furthermore, the centerline of bearing should be located at least one meter from the facing. These rules are good engineering practices that result in a negligible amount of settlement under the beam seat. In finite element analyses, the amount of settlement under these conditions, with the normal density of metal reinforcements, is on the order of 7.5mm (Fig. 29).

Backwall

For large bridges, either in terms of span or traffic volume, a backwall that may include the stationary part of the bridge deck expansion joint is incorporated into the beam seat (Fig. 30a). For others, where this joint is not necessary, the beam seat consists of a simple thick concrete slab, and the bridge deck is isolated from the embankment by a cast-in-place end section at the end of the bridge beams (Fig. 30b).

Approach Slab

Reinforced Earth abutments do not require approach slabs. In fact, there is no differential settlement between the approach embankment and the bridge deck, since the latter is supported by the embankment itself. At the most, a short approach or transition slab is sometimes provided on large girder bridges to accommodate any small settlement that may occur in the fill behind the backwall itself (Fig. 31).

Jacking Recesses

As with any other type of abutment, spaces are normally provided between the beam seat and the bridge roadway for lift jacks in anticipation of maintenance work on the bearing pads.

For abutments built on highly compressible soils, the jacks also make it possible, if necessary, to compensate for secondary settlement due to consolidation of the foundation soils.

It should be noted that if the jacks are located in front of the normal centerline of bearing of the bridge, jacking will constitute a special loading condition that must be taken into account in the design calculations of the structure.

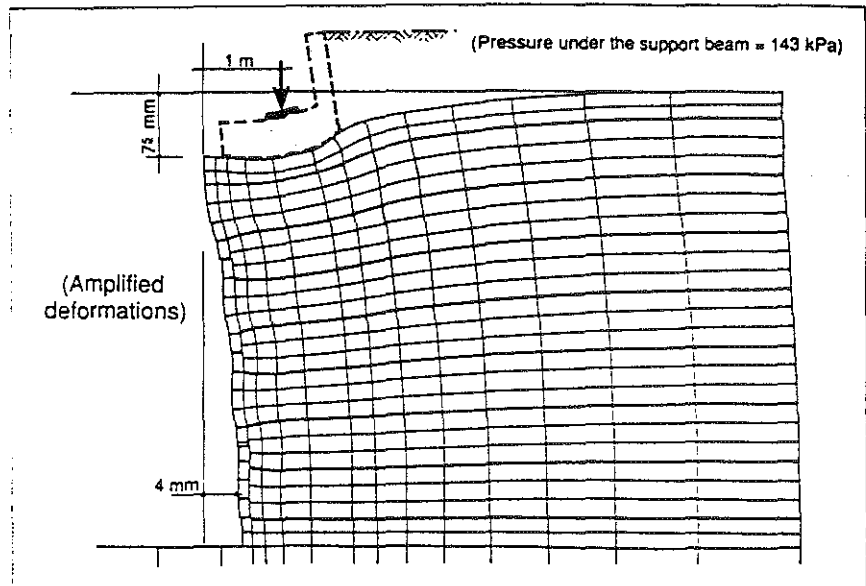
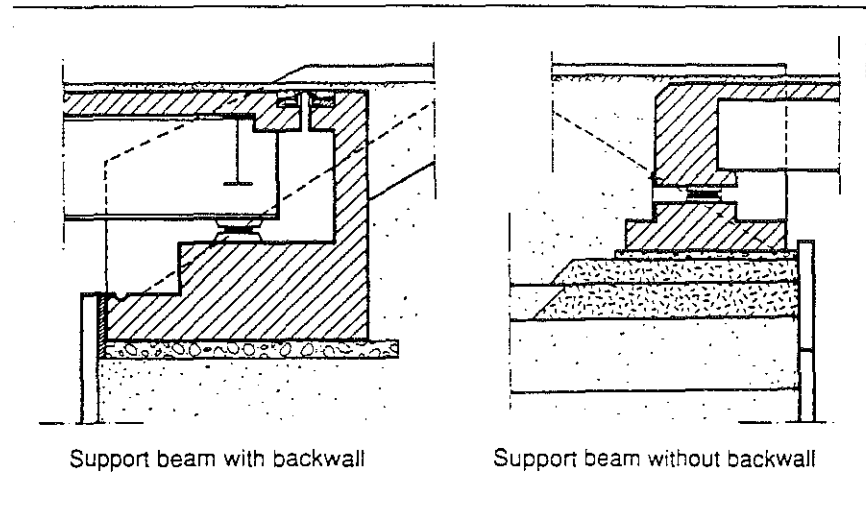

Figure 29: Amplified deformations of an abutment (finite elements).



Figures 30a, 30b: Typical details of bridge seats.

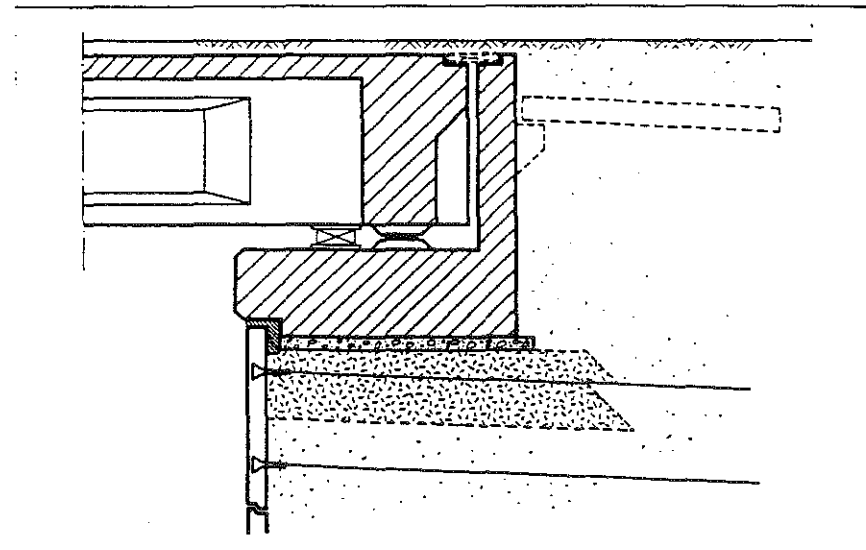

Figure 31: Typical details of a girder and bridge seat: lift jacks and approach slab, if applicable.

Essentially, there are two types of Reinforced Earth bridge abutments: closed abutments with return walls, and open abutments with wing walls. The choice between these two types depends primarily on site conditions and constraints.

Closed Abutments

Return walls are required when the access ramp to the bridge is confined by long retaining walls. If this type of abutment is also chosen for shorter return walls, constraints will be imposed on the installation, including several successive foundation levels for the return walls and a delayed completion of the top portion of the return walls until the beam seat and its cheek walls are completed.

Open Abutments

Wing walls may be collinear with the abutment itself, they may curve or angle slightly inward (Fig. 26), or they may be oblique (Fig. 27). The entire structure, including wing walls, is generally founded at the same level, and is built in a single phase prior to construction of the beam seat. No special equipment or coping is required at the top of the walls, which are topped out using special panels cast with sloping top edges. On the other hand, the extremities of the beam seat must be well protected against erosion. An additional benefit of open abutments with collinear wing walls is that their configuration easily allows for bridge widening should it become necessary in the future.

Skewed Bridges

Skewed bridges involve several design peculiarities. Rather than excessively skewing the reinforcements from a position perpendicular to the wall face and placing the backfill within a highly restricted sharp angle, it is preferred, where possible, to offset the return wall somewhat and truncate the point of the angle, with the reinforcements being angled only slightly from perpendicular to the wall face (Fig. 28).

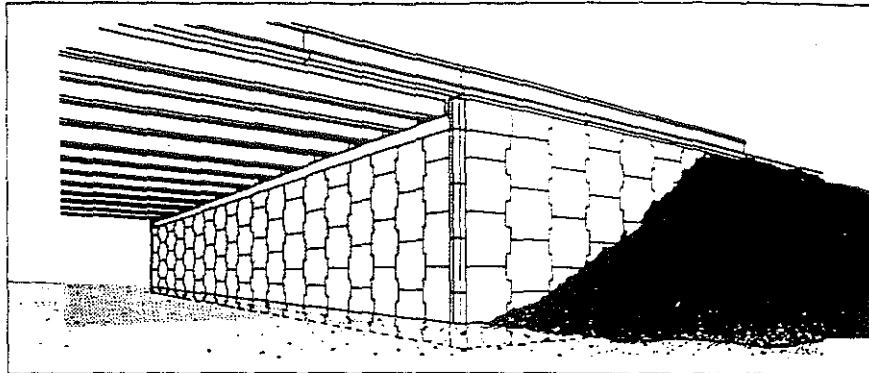

Figure 25: Closed abutment with return walls.

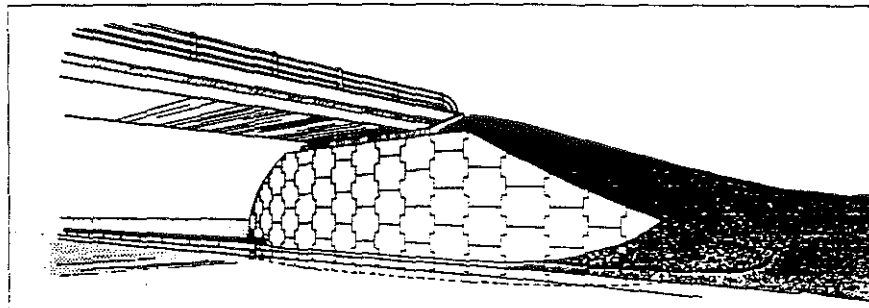

Figure 26: Open abutment with inwardly curved wing walls.

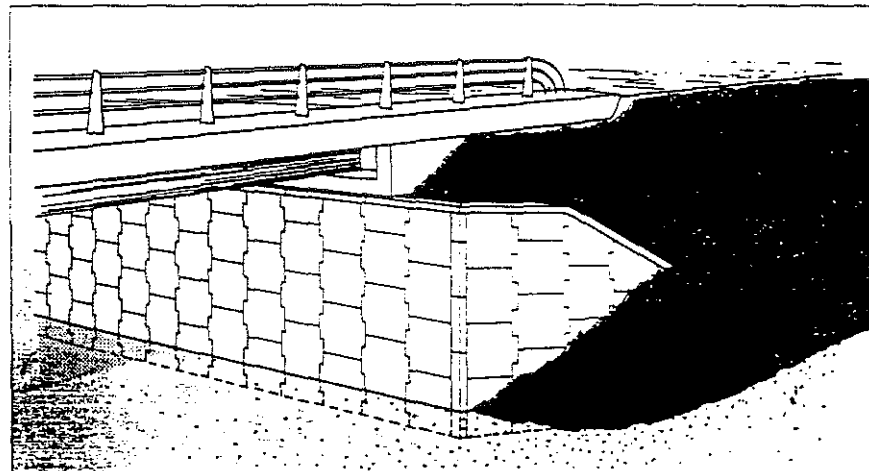

Figure 27: Open abutment with oblique wing walls.

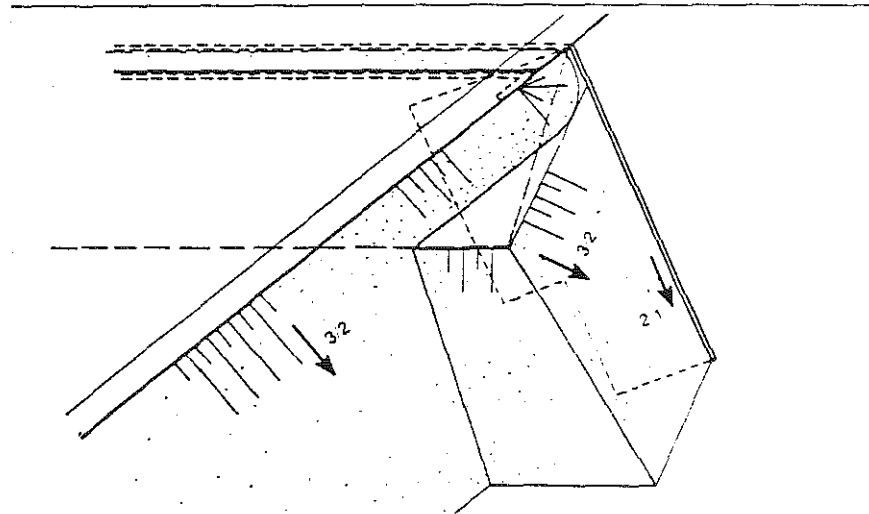

Figure 28: Details of the abutment for a skewed bridge.

Superimposition

An envelope of the total vertical stress (Fig. 21) is defined by:

$$\sigma_t = \sigma_{11} + \sigma_{12}(x)$$

Potential Failure Lines

In current analyses, the first potential failure surface drops vertically from the center of the beam seat and intersects the facing at a point located at depth 2ℓ . The second potential failure line is analogous to that observed in a retaining wall, or it passes by the heel of the beam seat.

Stresses in the Reinforcements

On the first or second potential failure lines, the tensile stress in the reinforcements, distributed as N per m^2 , is given by: $T = K \{ \alpha \sigma_{11} + \beta \sigma_{12}(x) \} / N$ (Fig. 22a). On the first line, α_1 equals 1.0 at the center line of the beam seat. At the facing it is equal to $\alpha_0 = "T_o / T_m"$; i.e., the ratio used at the same strip level in retaining walls. Over the remaining portion of the line, α_1 is interpolated. On the second line, α_2 is always equal to 1.0.

At the facing, $T_o = K \{ \alpha_0 \sigma_{11} + \beta \sigma_{12}(x) \} / N$. The coefficient β equals 0.85 under the beam seat and increases to 1.0 below a depth of 2ℓ .

K varies between K_0 at the surface and K_s at a depth of six meters (Fig. 22b).

For reinforcements located at a depth y below the beam seat, where y is less than ℓ , the tensile stresses are increased by: $\Delta T = 2F_n (1 - y/\ell) / N\ell$ (Fig. 23).

Sections of reinforcement are checked at both the gross section and at the net section with due consideration to service life design.

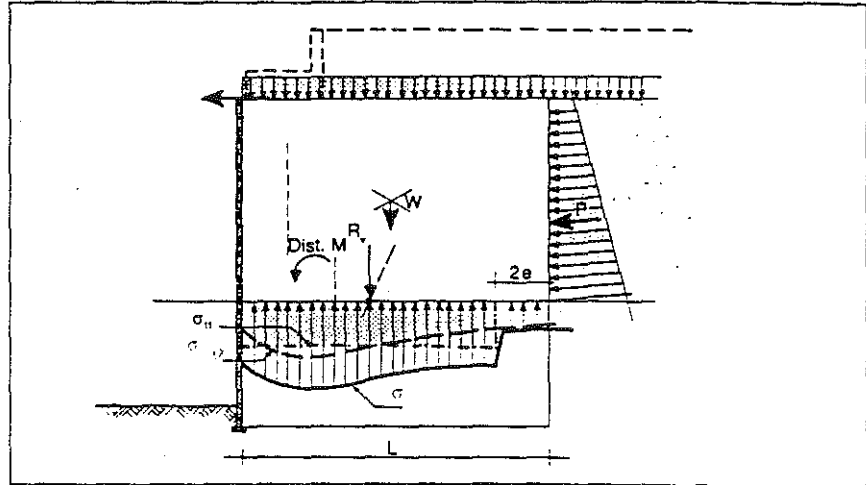
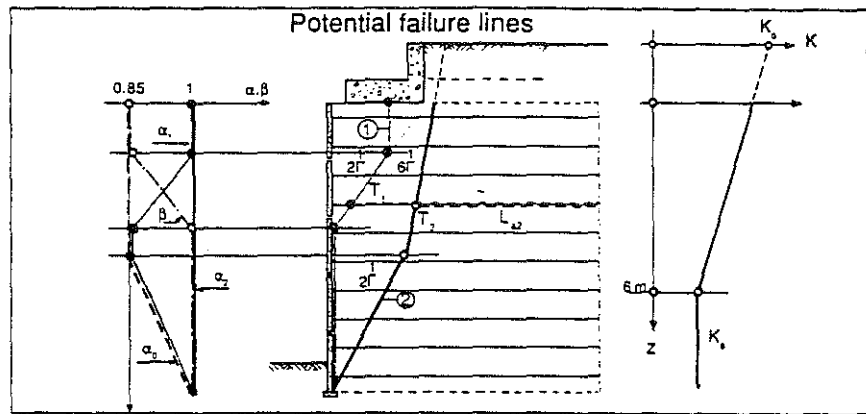

Figure 21: Superimposition of partial vertical stress coming from the support function (σ_{11}) and distributed loads [$\sigma_{12}(x)$].



Figures 22a, 22b: Calculation elements for tensile stress along potential failure lines.

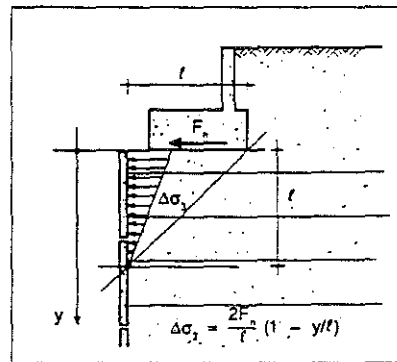

Figure 23: Transmission of concentrated horizontal stress.

Adherence

Adherence is checked for each of the two potential failure lines, one and two, and for the corresponding level of tensile stress, T_{m1} and T_{m2} . The computation consists of verifying by an integration over the length of adherence L_a (L_{a1} or L_{a2}) that:

$$T \leq \bar{T}_r = \frac{1}{\gamma} 2b \int_0^{L_a} f^*(x) \{ \gamma y + q_0 + \sigma_{12}(x) \} dx$$

For high-adherence reinforcements, f^* varies along the reinforcement and in relationship with: $\sigma_v = \gamma y + q_0 + \sigma_{12}(x)$, between $f^* = 1.5$ for $\sigma_v = 0$, and $tg \phi_r$ for $\sigma_v \geq 120$ kPa.

It should be noted that one design loading condition that may have a decisive effect on adherence conditions is that in which the backfill placement has only reached the level of the top of the beam seat while the total permanent load of the bridge is already in place.

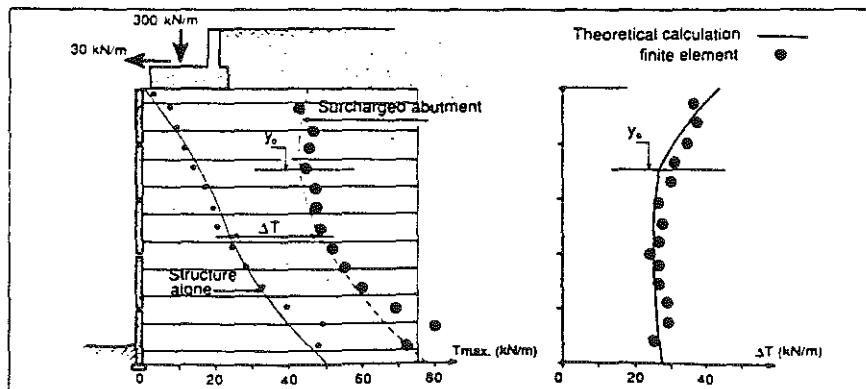

Figure 24: Agreement between the theoretical calculation and the finite element analysis.



The practical methods of computation apply to abutments in which the beam seat is of limited width and is situated slightly behind the facing.

Applied Loads

1. For all loading conditions to be considered, the forces exerted by the beam seat are expressed as a horizontal force, F_h , and an equivalent uniform vertical load, q , distributed over a width slightly smaller than the beam seat.
2. This vertical load, together with the loads imposed by the fill behind the beam seat, is replaced by an overall uniform surcharge, q_0 (as used in the retaining wall analysis), together with additional surcharge loads adjacent to the facing that simulate greater or lesser strip loads (equivalent, once superimposed, to the bridge seat load). Taken together, these surcharge loads are considered in the computation of distribution (Fig. 19).

Stress Distribution

1. Distribution toward the rear of each loaded strip is computed using Boussinesq's equation:

$$\sigma_w(x,y) = \frac{q}{\pi} \left\{ \frac{t}{1+t^2} + \text{arc tg } t \right\} \quad \begin{matrix} t_2 = (x+a)/y \\ t_1 = (x-a)/y \end{matrix}$$

At each reinforcing strip level the value of σ_w as a function of the distance x from the face, which corresponds to each of the strip loads, is summed up:

$$\Sigma \sigma_{v,v} = \sigma_{12}(x,y)$$

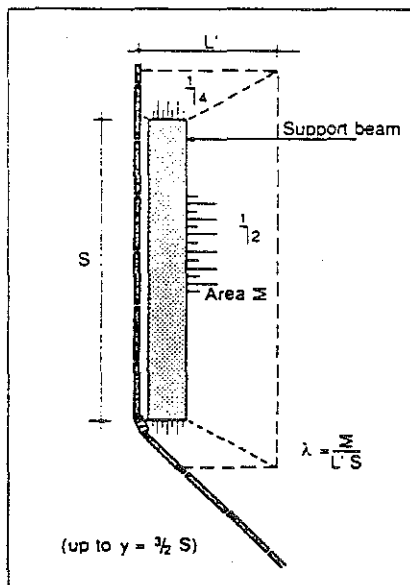

Figure 20: Principle of estimating lateral distribution.

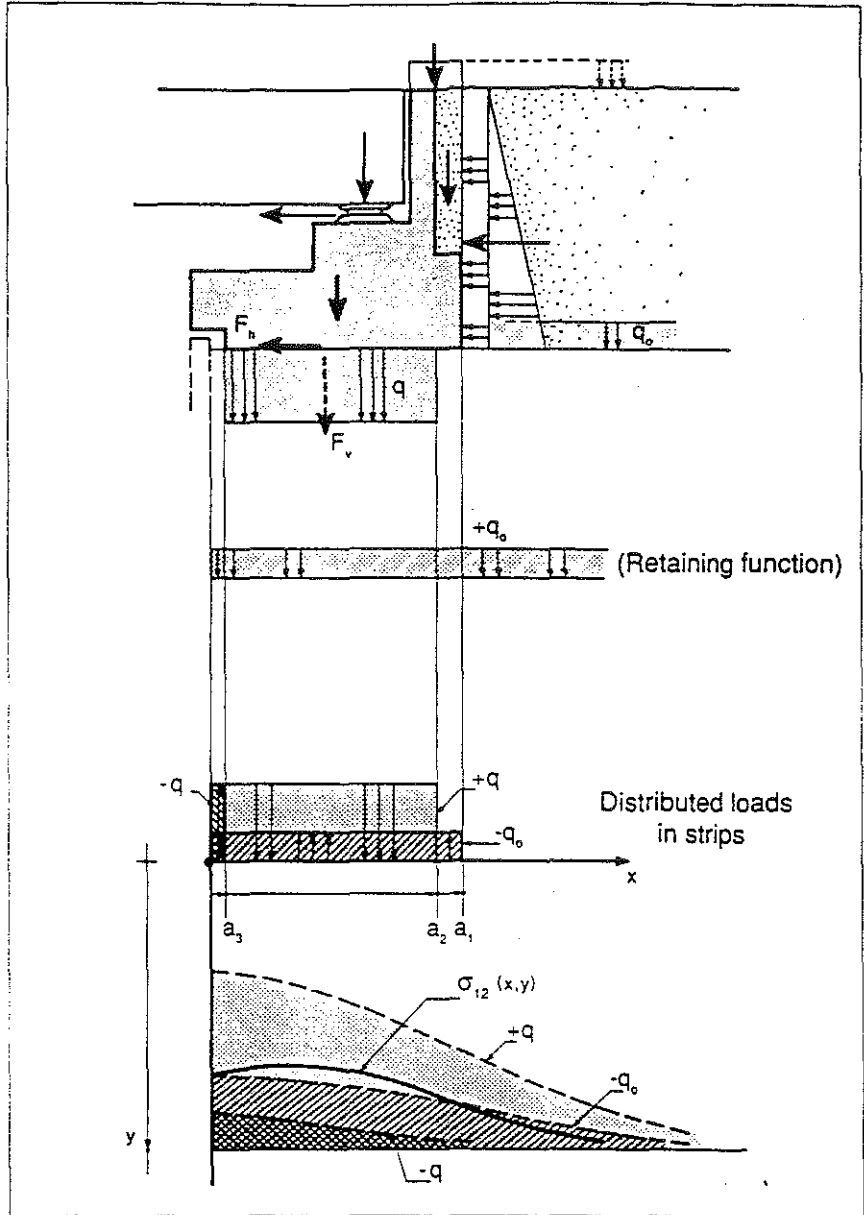

Figure 19: Principle of the decomposition of distributed loads, for the superimposed calculation.

2. Lateral distribution is estimated in simplified fashion by a truncated pyramid, possibly curtailed by the wing walls. From this distribution a reduction factor λ of σ_w may be deduced (Fig. 20).
3. The loaded strips are distributed only to depth y_0 where $d\sigma/dy = 0$ for the maximum total stress. In practice, y_0 is given by the equation:

$$y_0^2 - (L-2e)y_0 + 0.83 \ell^2 = 0$$

where ℓ is the width of the beam seat measured from the face and e is the eccentricity calculated from the earth retention computation.

Earth Retention Stresses

To the moment produced by the earth pressure and the horizontal force at the top of the structure are added the moments arising from the shifting of the diffused bridge loads as follows:

$$M_i = \lambda \frac{q_i a^2}{\pi} \left\{ \rho + (1+\rho^2) \left(\frac{\pi}{2} - \text{arc tg } \rho \right) \right\}$$

where $\rho = y/a$, and $y \leq y_0$.

Under the effect of these moments, the resultant of all of the vertical loads (except those which are distributed) is characterized by an eccentricity e . This corresponds to a uniform vertical stress:

$$\sigma_{11} = R_v / (L - 2e)$$

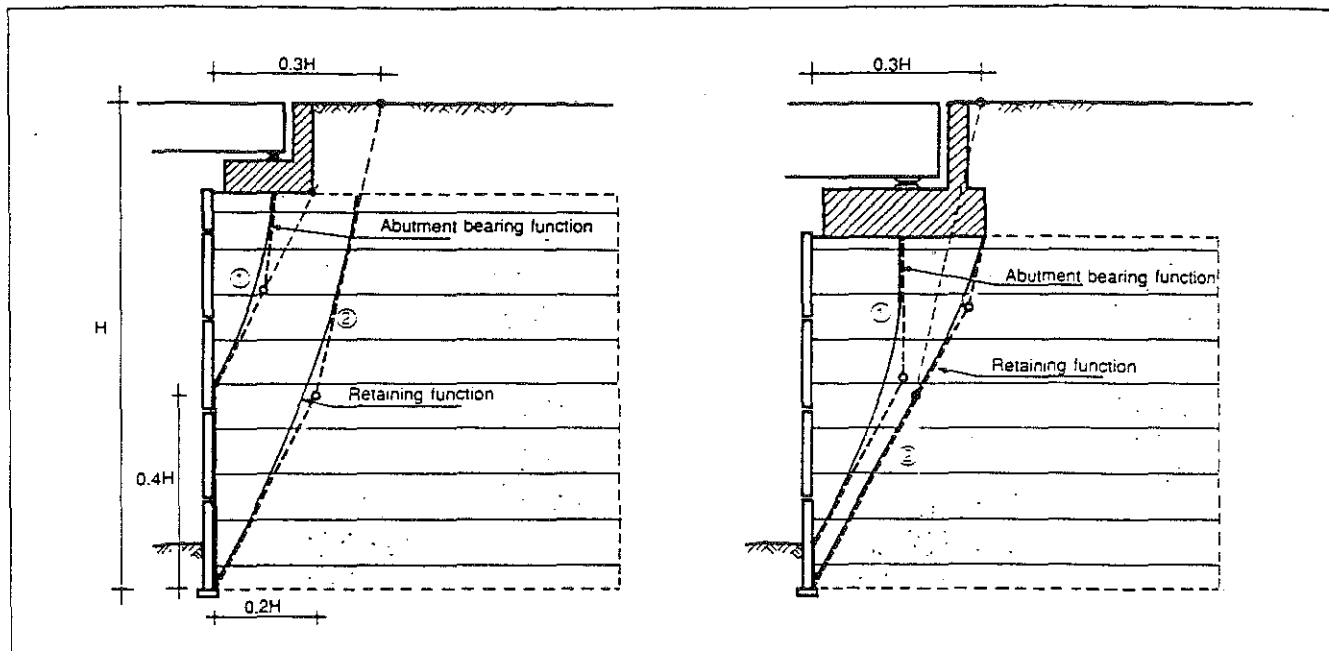

Figures 17a, 17b: Potential failure lines in a Reinforced Earth abutment.

The tensile stress measured along a reinforcement is the resultant of the combined effects of the two loading conditions previously discussed.

Due to earth retention conditions, a maximum tensile stress develops (which under certain circumstances may be a secondary maximum)

together with a potential failure surface similar to that observed in normal Reinforced Earth retaining walls (Fig. 17a). However, under the influence of wide beam seats, this line of maximum tension moves away from the face of the structure towards the heel of the beam seat. This potential failure line is always contained within the typical Coulomb failure wedge (Fig. 17b).

Due to bridge loading conditions, another potential failure surface develops. This surface originates at the top of the structure near the center of the beam seat and intersects the facing at the point of the critical wedge defined by the geometry of the beam seat (Figs. 17a, 17b). As a result, when relatively narrow beam seats are used, maximum tensile stresses are generally encountered near the facing, beyond this wedge.

Value of Maximum Tension in the Reinforcement

Experimental data confirms that the maximum tensile stresses (T_m) on both potential failure lines are again related to the total vertical stress exerted at the same points by the relation $T_m = K\sigma/N$, where N is the number of reinforcing strips per square meter of facing panel and K varies from K_0 to K_1 in the upper six meters of the structure.

Resistant Zones

The potential for the existence of two possible failure lines where the reinforcements are subjected to secondary maximum tensile stresses requires verification of adherence conditions over two different resistant lengths (L_{a1} and L_{a2}) (Fig. 18).

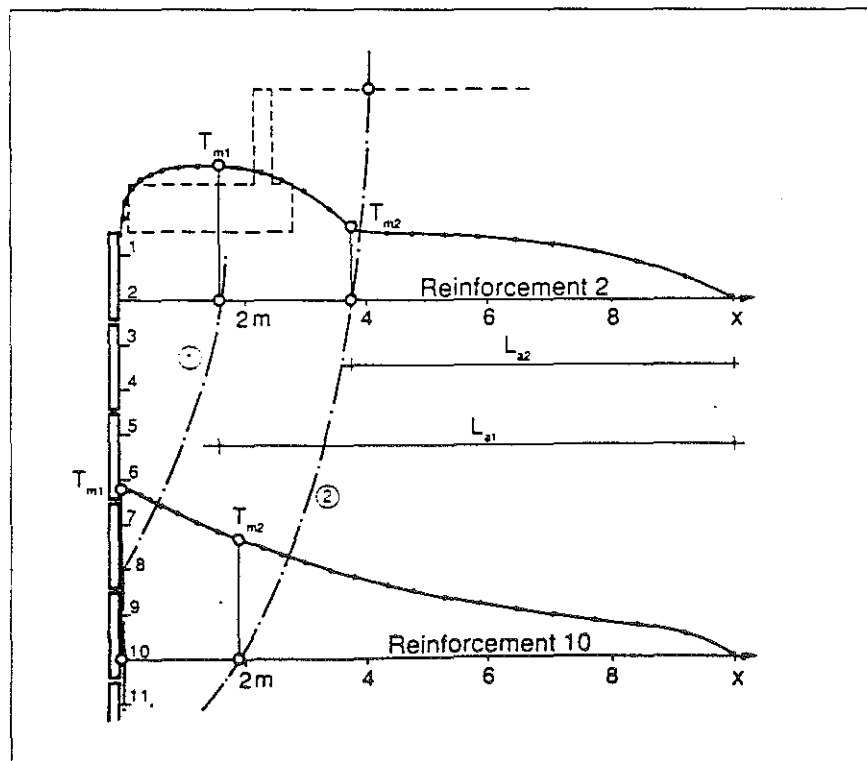

Figure 18: Relative maxima for tensile stress and corresponding strip lengths.



The Principle of Superimposition

Interpretation of experimental data and the results of finite element analyses have confirmed the reliability of analysis of an abutment structure by superimposing the stresses from two separate load conditions: stresses from the retaining wall conditions, and stresses caused by the bridge loading.

Stresses from Bridge Loading

Distribution:

The study of stresses arising from bridge loading involves the distribution of a vertical load within the reinforced volume. The results show that Boussinesq's formula (Fig. 15a) is perfectly satisfactory in defining this distribution, whether toward the rear of the beam seat (using an assumption of an equivalent symmetrical surcharge) or laterally.

As vertical stresses from the various surcharge loadings diffuse with depth, the center of gravity of the Boussinesq stress distribution moves away from the wall facing; that is, the resultant of the overall vertical stresses moves rearward. This movement of the resultant creates an overturning moment that increases with depth. This overturning moment must be considered in the overall stability of the structure as an increase in the stress component with depth (Fig. 15b).

However, the surcharge load is effectively distributed only insofar as it leads, in combination with this moment, to a dispersion of stress. This defines the depth limit y_0 for load distribution.

Horizontal forces:

The horizontal forces applied to the beam seat from the

superstructure and horizontal earth pressure behind the beam seat also create an increasing overturning moment. This moment affects the overall stability of the structure, even when these loads are transmitted first and directly to the uppermost layers of reinforcements, as indicated by finite element analysis (Fig. 16a).

Stresses from Retaining Wall Conditions

The study of stresses arising from earth retention follows standard Reinforced Earth retaining wall criteria. Thus, the effect of a structure's weight and the overturning moment generated by the active earth pressure behind it are considered. They are then taken in combination with horizontal loads and the overturning moments generated by the shift of vertical load distributions (Fig. 16b).

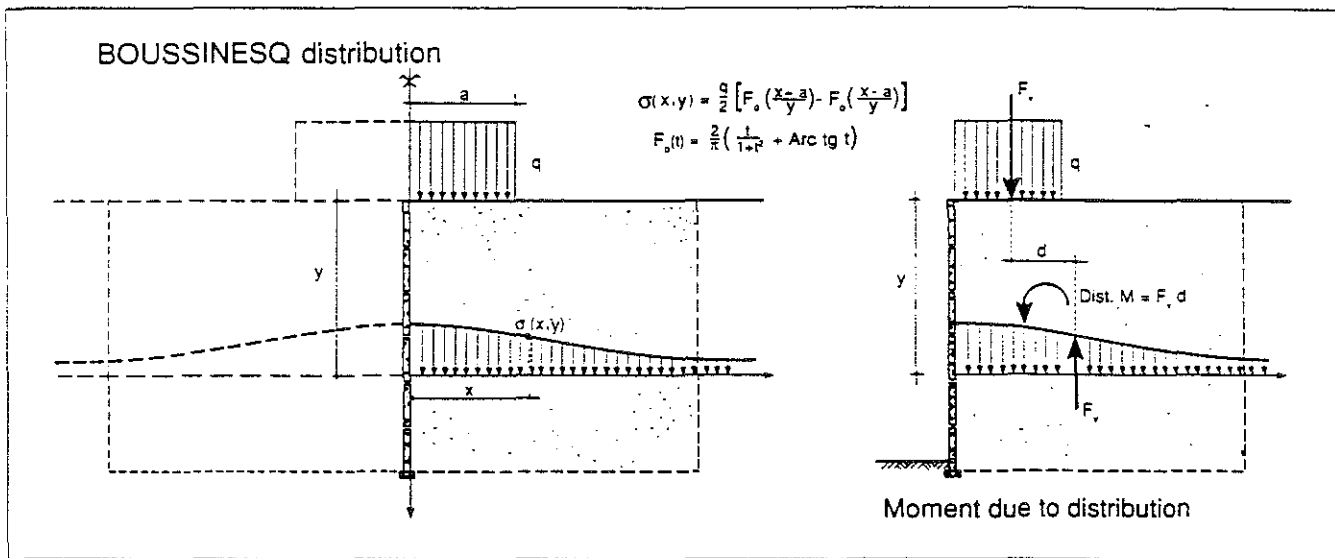

Figures 15a, 15b: Principle of the distribution of vertical loads according to Boussinesq.

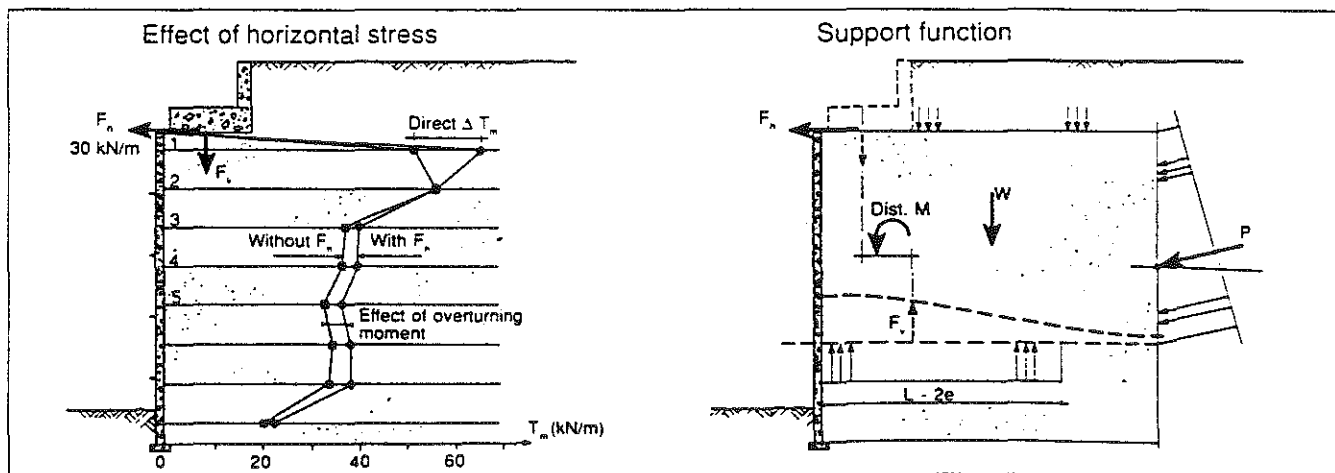

Figure 16a: Effects of concentrated horizontal stress according to the finite element models.

Figure 16b: Stresses assigned to the support function.

Principles

Mathematical models using the finite element method have also been used by Terre Armée Internationale to study the behavior of Reinforced Earth abutments and to analyze the influence of the principal design parameters. These models have been designed using the same elasto-plastic modelling principles as those used in the mathematical study of retaining walls. Computations were performed using a specially developed computer program, Rosalie.

Design Parameters Studied

In tests conducted in 1984 and 1985 by Terre Armée Internationale, more than 50 different mathematical models were studied in which the following parameters were simultaneously varied:

- The height of the Reinforced Earth structure (6.0 meters and 10.5 meters).
- The length of the reinforcements (7.0 meters and 10.0 meters).
- The distribution of the reinforcements, using three typical configurations that differed primarily at the top of the structure.
- The dimensions and load at the beam seat (Fig. 12) corresponding to a bridge with a ten meter span or a bridge with a 30 meter span.
- The loading conditions (Fig. 13), including the following four stages:
 1. The structure without surcharge loading.
 2. The structure completed to the top of the beam seat, with permanent bridge load in place.
 3. The finished structure with total vertical loads and surcharges.
 4. The same as #3 above, with horizontal reactions added.

Results

As in the study of retaining walls, graphic superimposition of the results in bridge abutments allowed direct observation of the development of tension in the various reinforcement levels as loadings were increased. Results were also obtained on the effects of the different design parameters (Fig. 14). Further, the vertical stresses at every level of reinforcement (particularly at the foundation) and the deformations of the structure were recorded.

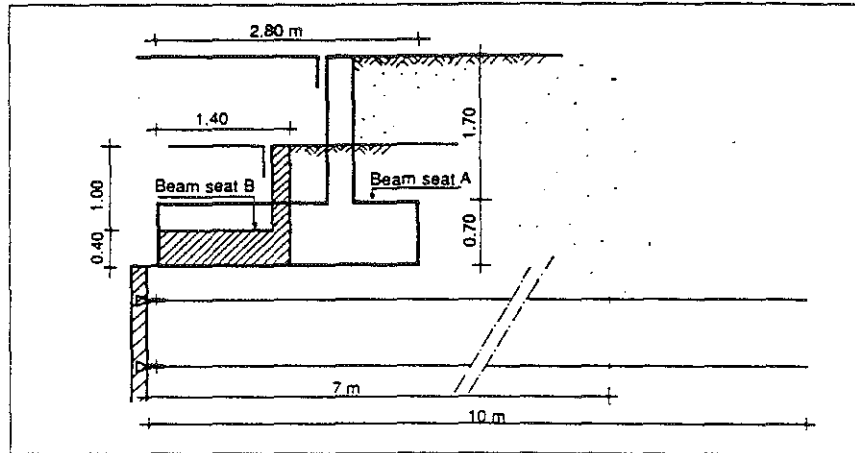

Figure 12: Finite element study: details of the two beam seats in question.

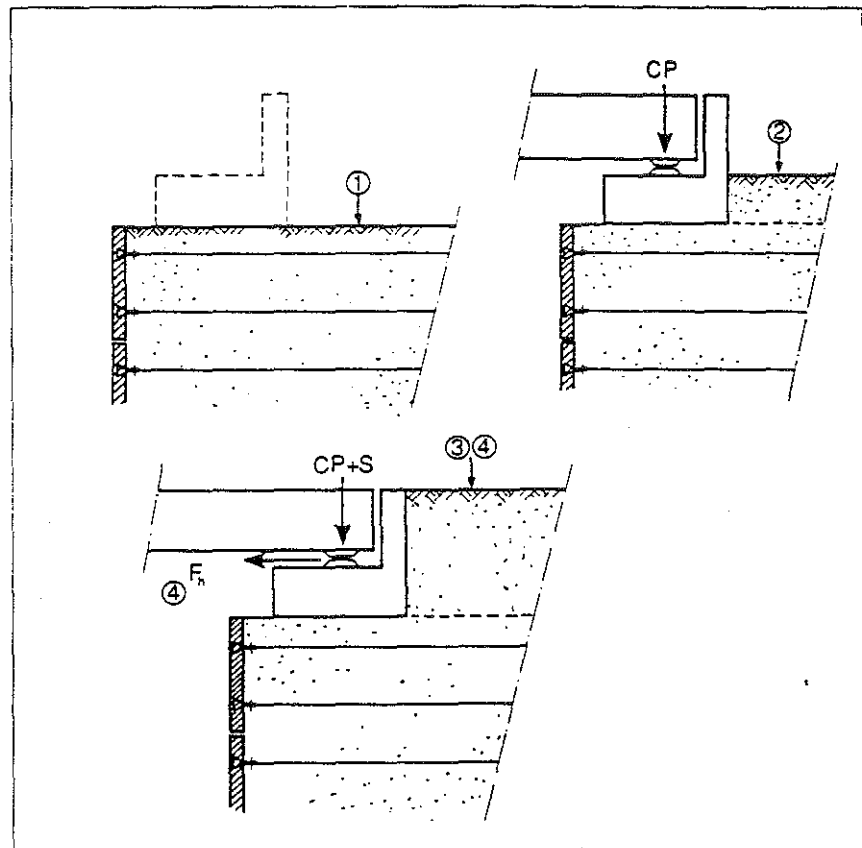

Figure 13: Drawings of the four successive types of loading conditions.

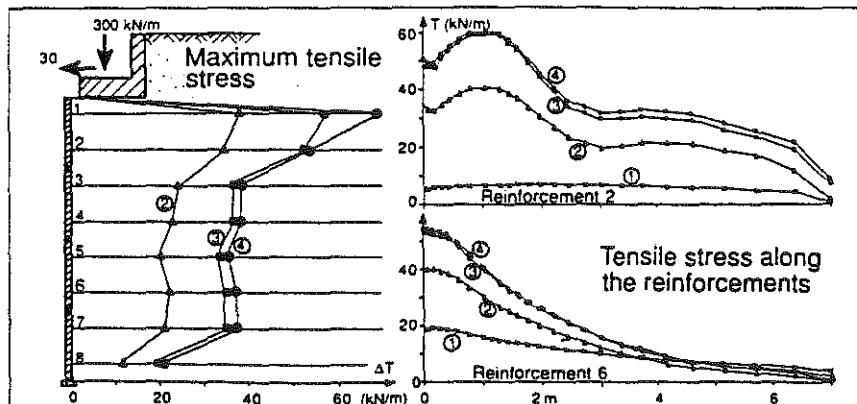

Figure 14: Examples of variations of maximum tensile stress and tensile stress along the reinforcements according to type of loading condition.



Studies Conducted by Terre Armée Internationale

The performance of several series of bi- and tri-dimensional reduced-scale models has been extensively studied in the laboratory. These models were subjected to surcharge loading similar to that exerted on bridge abutments.

One of the most interesting experiments was conducted in 1982 in the Paris laboratories of the Center for Research and Study in Soil Mechanics (CERMES) at the request and sponsorship of Terre Armée Internationale. The CERMES study involved three-dimensional sand models, 60cm high reinforced with thin aluminium strips. In order to eliminate side wall effects, the models were separated into three vertical sections.

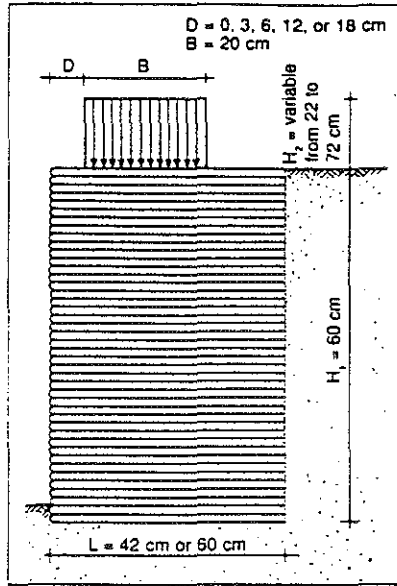

Figure 9: CERMES models loaded to failure.

Study of the Failure Mode

In the initial series, 15 models were loaded to failure under increasing loads placed at various distances from the face of the structure (Fig. 9). Propagation of the failure surface was observed by using lights mounted in series with the reinforcements. Upon disassembly, all failure locations were carefully measured. By incorporating correction factors to compensate for the effect of the rigidity of the base of the model, satisfactory agreement was obtained between the measured experimental failure loads and those predicted by theoretical computations (Fig. 10). In addition, it was consistently noted that the failure surface is influenced by the location of the surcharge. (The analysis of all results clearly indicated that the location of the failure surface is relative to the location of the surcharge load.)

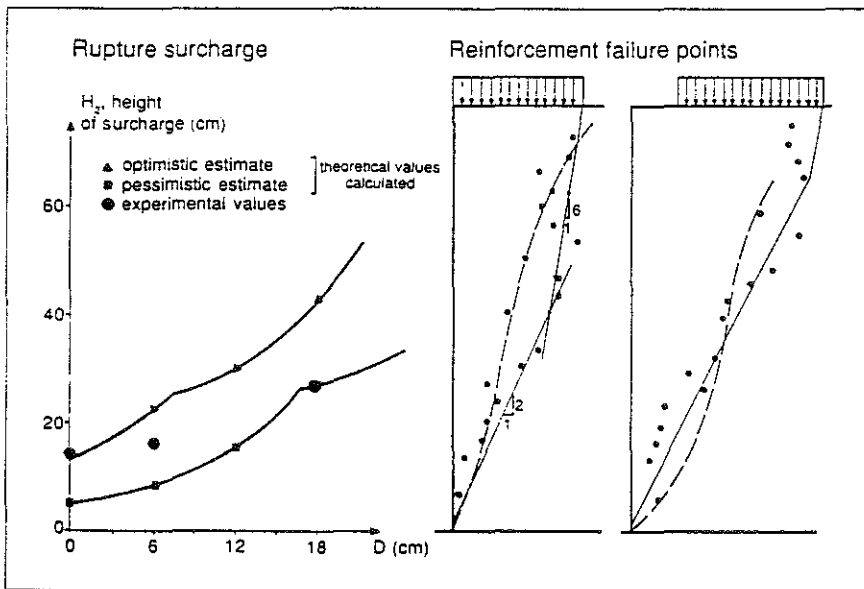

Figure 10: CERMES models. Recordings of loads and failure lines.

Stress Measurements

In two other series, models of equal height (60cm) were subjected to 19 different loading conditions, with stresses measured using 30 strain gauges attached to the 0.2mm thick reinforcements (Fig. 11). Although it is difficult to accurately and reliably measure strains at the low levels of stress inherent in reduced-scale models, it is possible to observe a rather close agreement between the experimental and theoretical values, and the magnitude and location of maximum tensile stress in the reinforcements. Near the top of the structure, the location of the maximum stress in the reinforcements was observed to shift towards the midpoint of the load, away from its normal location in retaining walls.

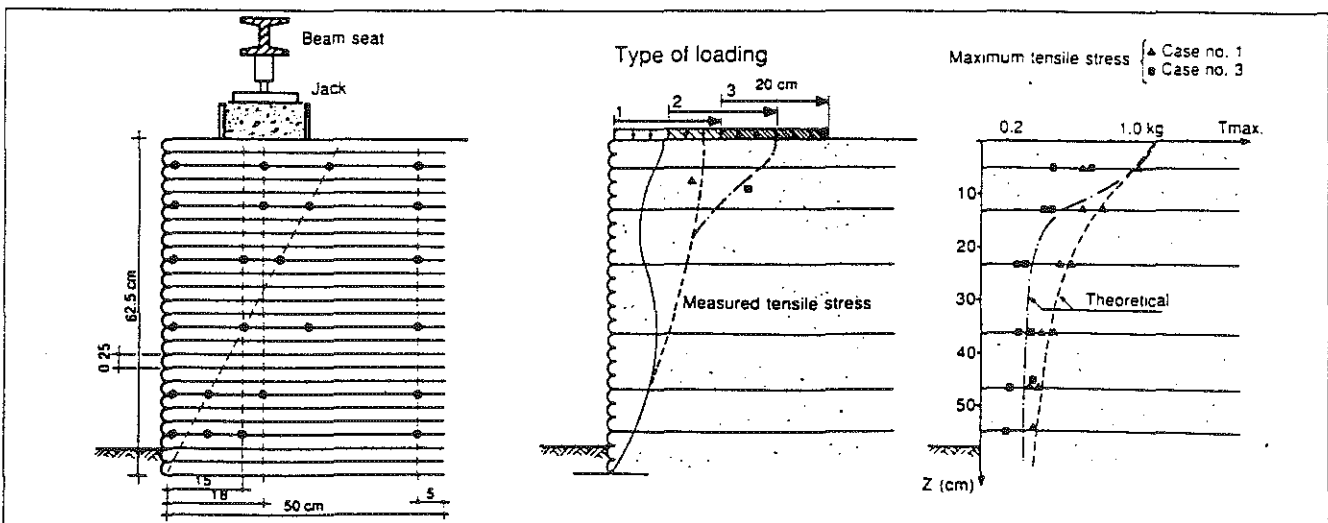

Figure 11: Models with wire strain gauges. Maximum tensile stress readings.

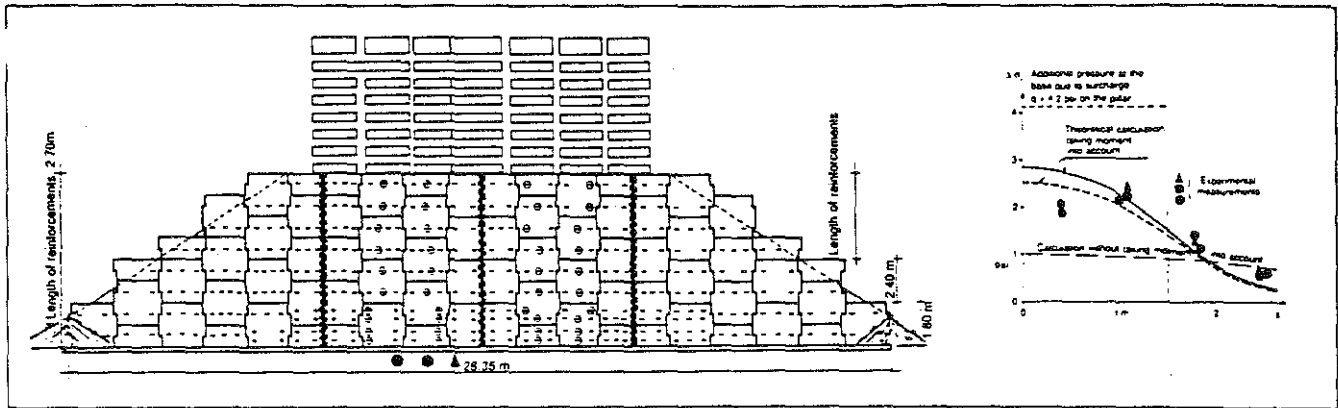

Figure 6: Surcharged experimental structure at Millville, USA.

Other measurements have been taken on full scale experimental walls supporting heavy, concentrated loads in the form of concrete slabs or steel bars placed directly behind the facing panels.

Triel

In the experimental wall at Triel in France, built by La Terre Armée in 1975, surcharge loading was successfully increased to 90 kPa over a two-meter width behind the facing. The measurements, which involve three levels of reinforcements, are very reliable and conform well to the theory, especially with respect to load distribution.

Millville

At Millville in the United States, The Reinforced Earth Company built an experimental wall using short reinforcements. This structure was gradually subjected to a load of 40 kPa over a width of 1.5 meters (Fig. 6). Due to the wall's very narrow profile ($L/H = 0.45$), the structure was more sensitive to the effects of moments developed by overturning, particularly those produced by the eccentricity of the surcharge. The vertical stresses measured by pressure cells placed under the entire width of the structure clearly demonstrated the need for designers to consider these moments in the computation of load distributions.

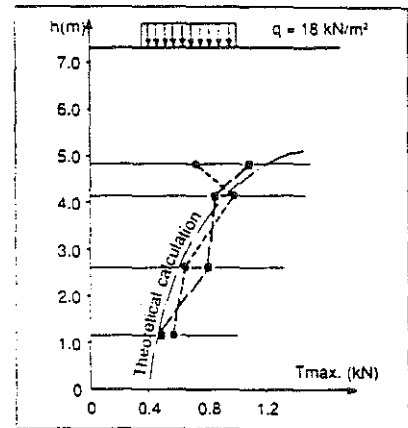

Figure 7: Tensile stress measurement at Fremersdorf, Germany.

Fremersdorf

The Fremersdorf Wall constructed in Germany in 1980 was built for normal earth retention service, not for experimental purposes. However, the owner took the opportunity to experiment before the wall was placed in service. A localized, temporary load of 650 kN was placed on the reinforced volume at a point slightly further behind the wall facing than usual for a typical Reinforced Earth abutment load. The additional stresses measured in the reinforcements were in remarkable conformity with theoretical predictions based on abutment design methods (Fig. 7).

Fontainebleau

In 1988, a large, narrow, experimental wall built at Fontainebleau, France, by the Reinforced Earth Group was prepared for subjugation to concentrated surcharges analogous to those experienced by an abutment. Its upper portion was modified to form a layer of unreinforced fill overlaying the uppermost reinforcements. Loads were designed for distribution through vertical tension rods anchored in the subsoil (Fig. 8).

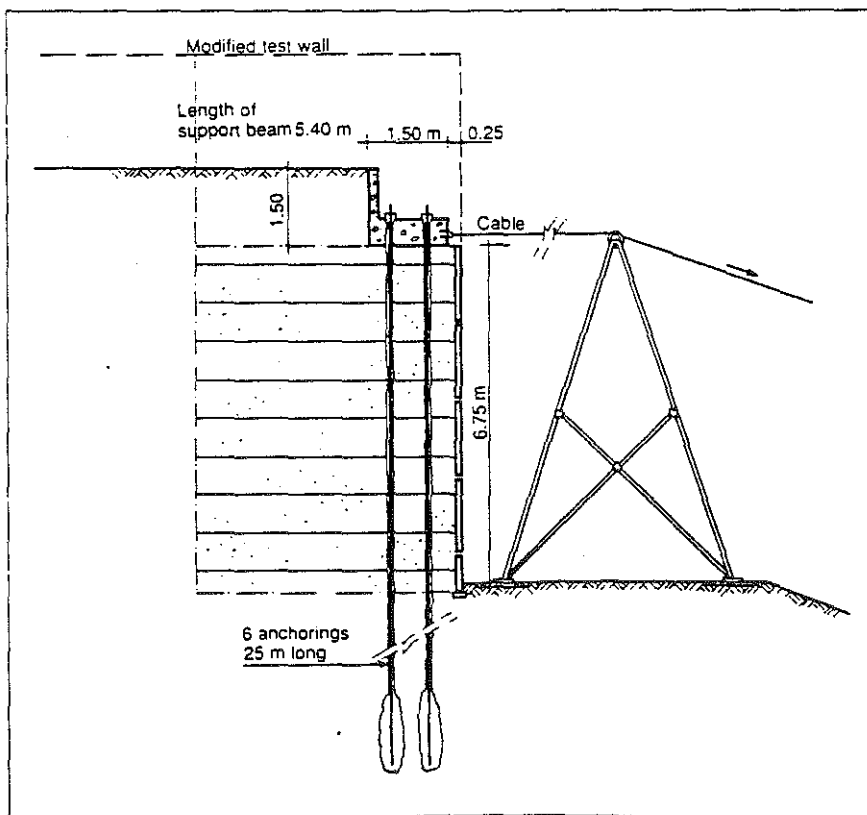

Figure 8: Application of surcharges to the Fontainebleau experimental wall.

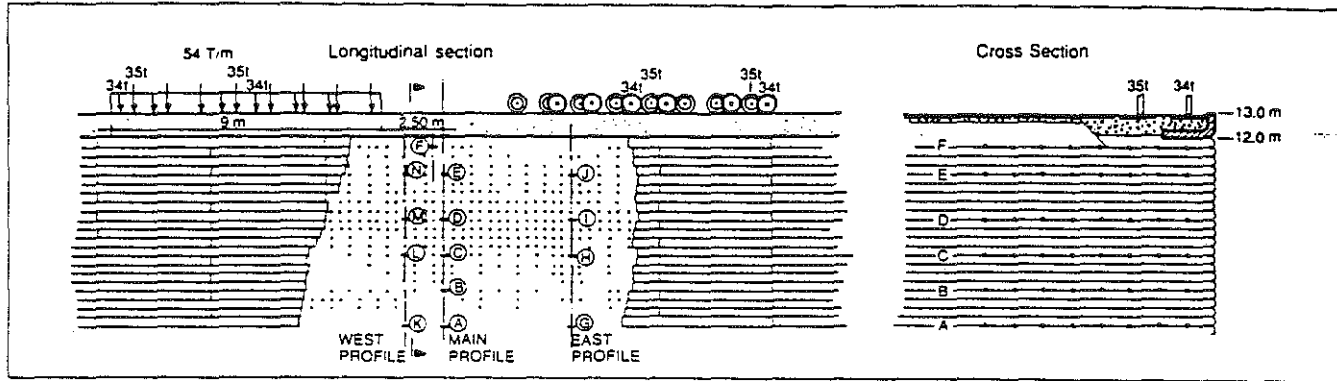

Figure 3: Measurement profiles. Dunkirk structure.

M easurement Principles
 A number of in-service structures have been instrumented with strain gauges and pressure cells to measure the effects of concentrated loads from bridge superstructures. These effects are derived by measuring and comparing the relative tensile stress levels in the reinforcements prior to and then following placement of the superstructure.

Dunkirk

The Port of Dunkirk structures do not carry the relatively static loads of a bridge superstructure. Rather, loads are imposed by two traveling gantry cranes (Fig. 3). Consequently, the interpretation of data is somewhat complicated—both by the presence of residual stresses which diminish slowly after a crane has passed, and

by the uncertainties associated with the manner in which the concrete supports distribute the localized load of the wheels. Nevertheless, measurements made along several cross-sections clearly indicate a variation in additional tensile stresses in the reinforcements from one level to another, as well as the influence of lateral distribution of the load from one section to another (Fig. 4a).

Abutments in France

The abutments that were instrumented at Thionville, Angers, and Lille have made it possible to assess the effects of each construction phase on the development of maximum tension levels in the reinforcements for abutments of differing sizes and proportions subjected to varying loading conditions (Fig. 4b).

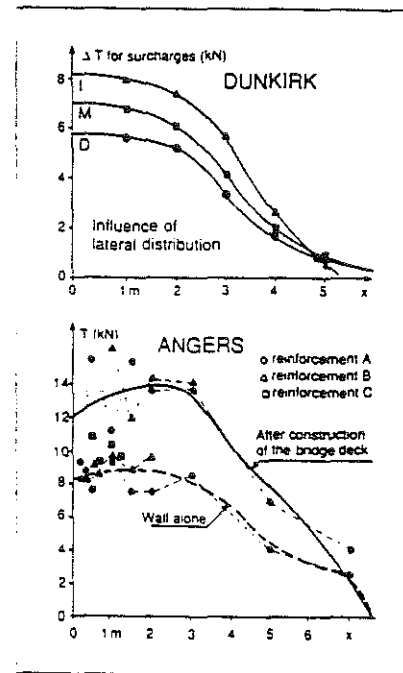

Figures 4a, 4b: Tensile stress measurement in reinforcements at Dunkirk and Angers.

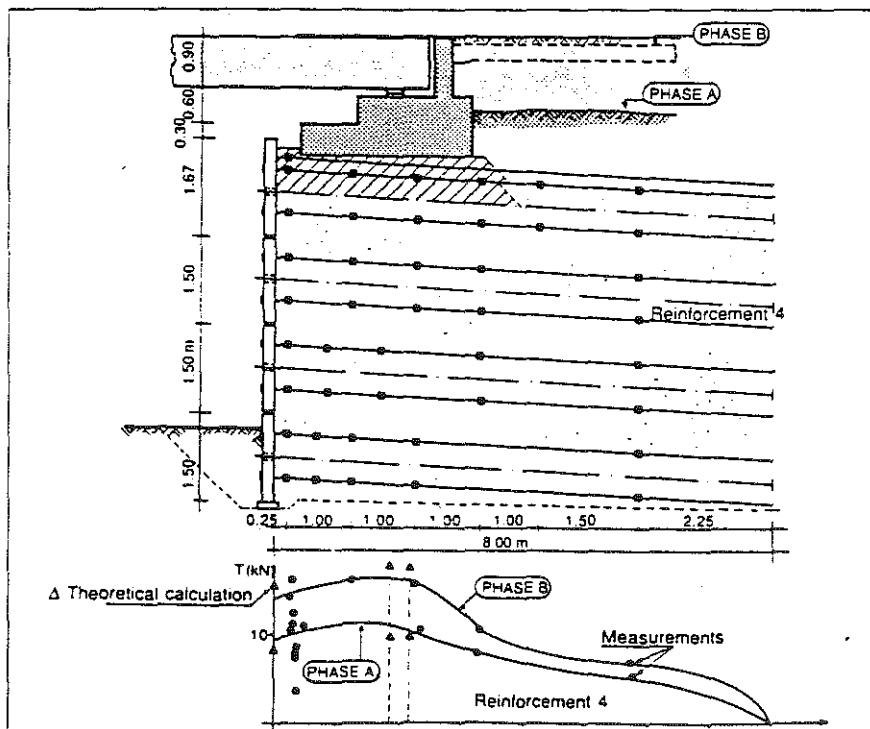

Figure 5: Tensile stress measurement at Amersfoort.

Amersfoort

The most accurate and complete set of measurements on an in-service abutment are those obtained at Amersfoort, the Netherlands, in 1984 (Fig. 5). In this structure built for the Ministry of Public Affairs/Department of Bridges, forty-two measurement points were distributed over eight levels of reinforcements. Readings were taken at six successive stages of construction. The results of the measurements were in close agreement with computations made according to state-of-the-art design procedures, taking into account that the stiffness of the foundation soil at the base of this structure greatly reduces the tension in the lower levels of reinforcement strips. Deformations of the facing were also monitored using rods anchored in the fill well behind the Reinforced Earth mass. Measured movements of the facing were less than 0.1mm.

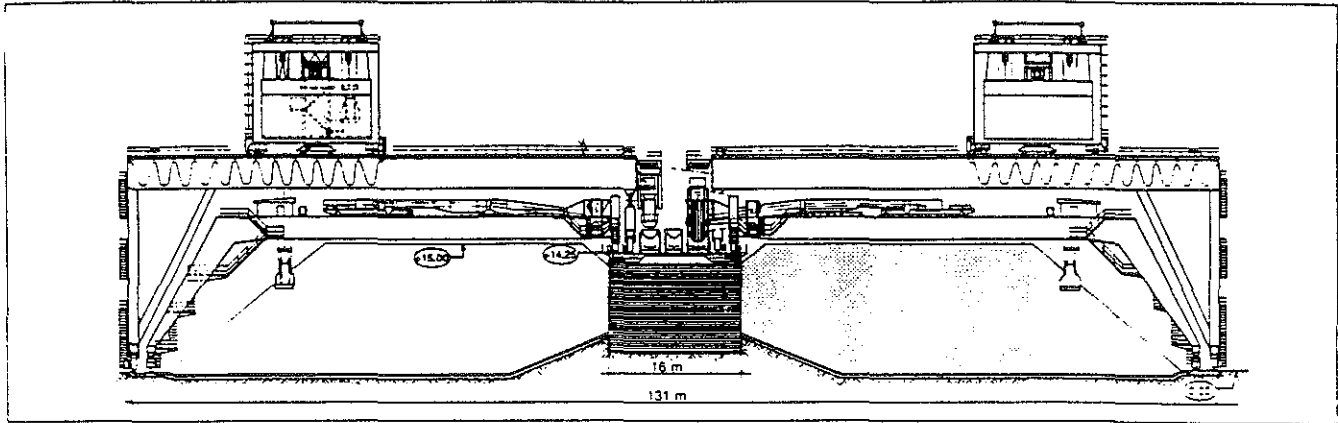

Figure 1: Ore storage at the Port of Dunkirk, France.

In 1969, the successful construction and performance of several very high retaining walls demonstrated that Reinforced Earth technology could also be used for the construction of bridge abutments.

1969—Strasbourg

The engineering department of Electricité de France provided an opportunity to confirm this thinking on a bridge project near Strasbourg. La Terre Armée, Paris, designed and supervised the construction of two abutments for a bridge to carry very heavy truck loads on a service road leading to hydroelectric dams on the Rhine River. These first abutments proved to be both technically and economically successful.

1972—Thionville

Following construction of the Strasbourg prototype structures, the first highway abutment was built at Thionville, France, in 1972. The structure is 18 meters high and supports the end span of a 78 meter-long prestressed concrete viaduct that crosses the Moselle River on the Nancy-Luxembourg Highway.

(A second bridge has since been added. It is supported by a portion of the Reinforced Earth abutment built for this purpose 15 years before.)

Dunkirk

The ambitious Thionville project was made possible by the successful construction of a large coal and ore loading facility at the Port of Dunkirk, France. Reinforced Earth's inherent earth retaining capacity and exceptional load handling characteristics were utilized in the design of parallel walls, up to 15 meters high and 550 meters long, to create a storage area and to support traveling gantry cranes with wheel loads in excess of 1,000 tons (Fig. 1).

This heavily surcharged structure, like Thionville, was extensively instrumented. Analysis of the results served as the basis for the rational design procedures utilized for subsequent Reinforced Earth abutments. Fifteen years after Dunkirk, more than 1,700 bridge abutments were in service worldwide.

Conceptual Design

A Reinforced Earth abutment essentially consists of a conventional

Reinforced Earth retaining wall designed to support the earth pressures behind it, as well as the heavy, concentrated vertical and horizontal surcharge loads imposed on it by the bridge superstructure and traffic loadings (Fig. 2a). Superstructure loads are transmitted by a reinforced concrete beam seat which distributes the stresses to the top of the Reinforced Earth structure (Fig. 2b).

Research on Abutment Behavior

Research studies have been conducted in a variety of ways, including theoretical research using computer modelling, as well as the instrumentation of scale models, prototypes, and full-scale in-service structures. These studies conclusively demonstrated the mechanisms by which the loads imposed by the beam seat affect the behavior of the Reinforced Earth mass, and how these loads are subsequently distributed through the mass to the foundation soils. They have provided the means to accurately predict tension in the reinforcements and deformation of the Reinforced Earth structure as a whole.

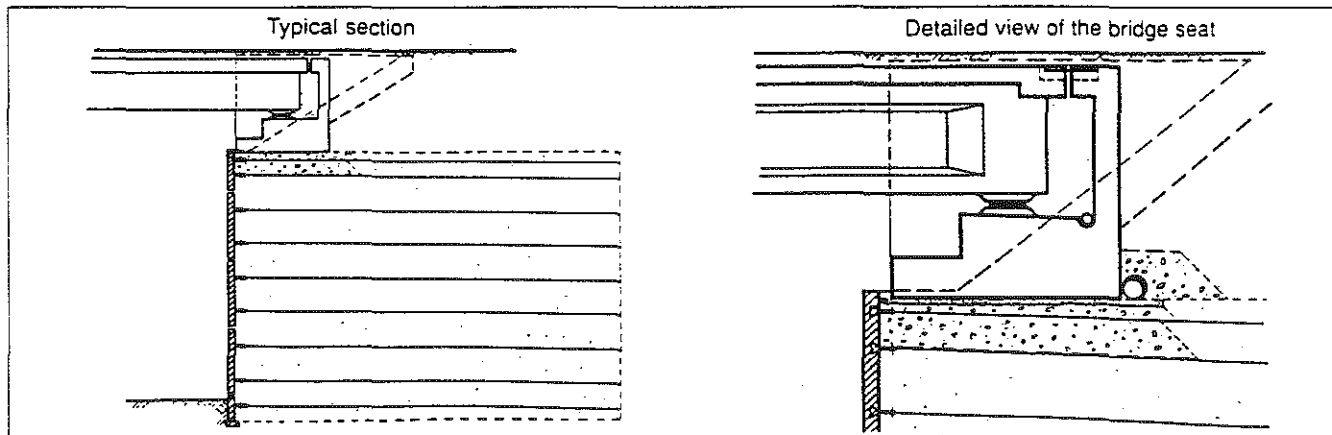

Figures 2a, 2b: Typical diagrams of a Reinforced Earth abutment and the seat.

SUMMARY

Early on in the use of Reinforced Earth® to construct very high or very heavily loaded retaining walls, it was found that this technology could be easily adapted to the construction of abutments for the direct support of bridge superstructures. However, although the general principles involved are the same, the concentrated loads created by bridge superstructures significantly affect the distribution of stress and strain within the reinforcements. As with research on Reinforced Earth retaining walls, studies on the effect of such loadings and the development of increasingly precise design methods included measurements of actual projects, reduced-scale models, and finite element studies.

In the design of load-bearing abutments, detailed analysis of the abutment geometry, of the bridge supporting structures, and of the provisions for handling water are required. Construction demands strict adherence to the specifications governing the selection and compaction of backfills.

Reinforced Earth's inherent flexibility makes it possible to construct bridge abutments on soft soils. Special foundations are not required, although in some cases simple soil improvement techniques are recommended.

The design and construction scheduling of each project must take into consideration the characteristics of the superstructure, phasing and waiting-period requirements, geotechnical data, and the inherent properties of Reinforced Earth construction.

In special cases, it may be necessary to separate the retaining and bearing functions of a structure by constructing a mixed abutment. In such cases, if the foundation soils are good, the use of a "pier abutment"—a type of mixed abutment with interior supports—may be viable.

The worldwide experience gained in developing various designs and configurations of hundreds of abutments enables Reinforced Earth engineers to determine the optimum solution for each application.

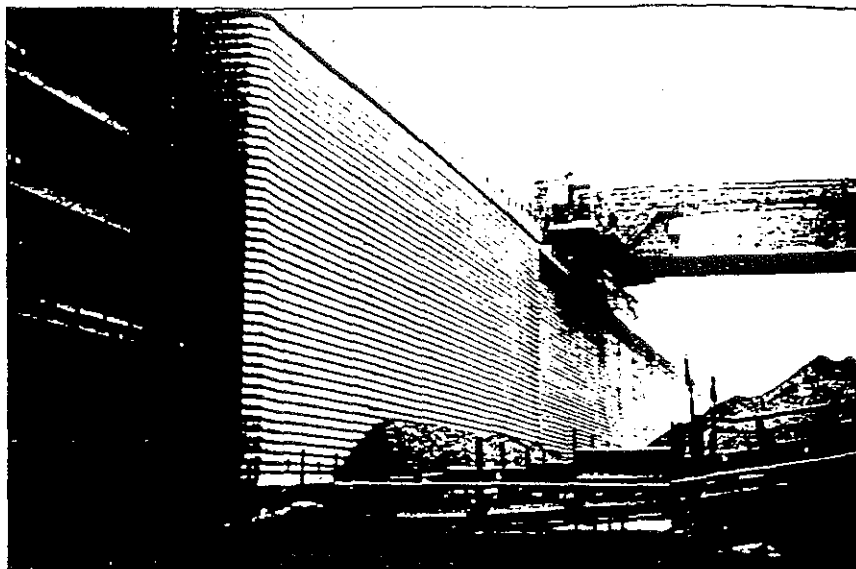

Dunkirk



Thionville

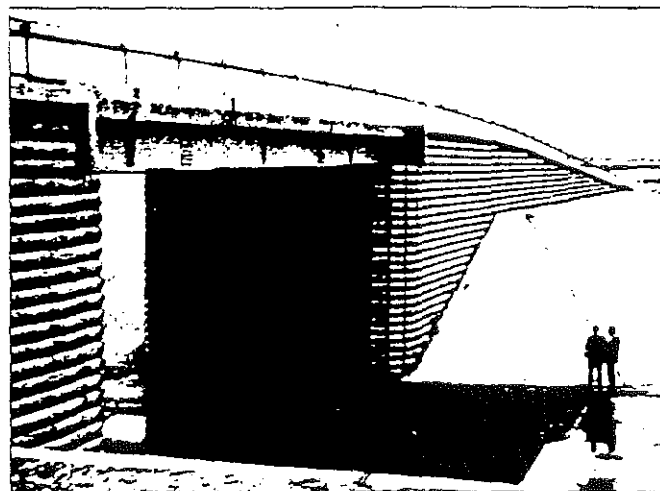

Strasbourg