

**Research Report  
UKTRP-86-23**

**MANUAL  
ON  
BRIDGE/CULVERT MAINTENANCE**

**by**

**Gary W. Sharpe  
Chief Research Engineer**

**and**

**Theodore Hopwood II  
Chief Research Engineer**

**Transportation Research Program  
University of Kentucky**

**In cooperation with  
Kentucky Transportation Center  
University of Kentucky**

**The contents of this report reflect the view of the authors who are responsible for the facts and the accuracy of the data presented herein. The contents do not necessarily reflect the official views or policies of the University of Kentucky or the Kentucky Transportation Center. This report does not constitute a standard, specification, or regulation.**

**September 1986**

## PREFACE

### OBJECTIVES

The basic objective of this course is to provide background (introductory) technical information that will aid the manager of bridge/culvert installations. In most instances, information presented may not be sufficiently complete for the student to perform the required work. However, the intent is more to familiarize than to instruct. In many instances, professional engineering and experienced labor are necessary to ensure successful completion of tasks. Once the local official responsible for bridges and culverts has completed this workshop, he should have a basic understanding of

- the most common bridges/culverts encountered in counties and municipalities,
- the major components of common bridge/culvert types and their functions,
- common bridge/culvert materials,
- material deterioration in bridge/culvert service,
- various bridge/culvert maintenance requirements,
- specific bridge/culvert rehabilitation techniques, and
- decision-making procedures for bridge/culvert management.

### SCOPE

The course addresses the general area of bridge/culvert maintenance. For each of the topics listed below, a broad range of coverage is presented:

- bridge/culvert types and basic designs,
- bridge/culvert components,
- bridge/culvert materials,
- service deterioration of bridge/culvert components,
- routine maintenance procedures,
- special rehabilitation techniques, and
- bridge/culvert management techniques and decision-making processes.

Where possible, references have been indicated at the back of this manual. Bridge/culvert managers should attempt to continually add to their existing knowledge by reading from this list and also from relevant periodicals, books, and journals related to bridge/culvert maintenance. Some of the referenced literature may be obtained by request from the Kentucky Transportation Center.

This course is designed for presentation to employees of county and municipal governments responsible for bridges and culverts on secondary highways and local roads and streets. It is assumed that participants have some background and experience in public-works maintenance and operations, but only modest experience related to bridges and culverts. It also is assumed that the participants make at least some contribution to their governmental unit in the cost-estimating and budgeting process.

## **DISCLAIMER**

Every situation in which the information presented in this workshop will be used cannot be anticipated. Therefore, the reader is urged to use good judgment to determine when that information is applicable. When in doubt, do not hesitate to consult a knowledgeable professional engineer or materials consultant. No responsibility can be accepted for any adverse effects that result from application of information contained in this manual.

## TABLE OF CONTENTS

|     |   |     |
|-----|---|-----|
| 1.0 | INTRODUCTION TO BRIDGES AND CULVERTS.....             | 1   |
| 1.1 | Definitions.....                                      | 1   |
| 1.2 | Background.....                                       | 2   |
| 1.3 | Types of bridges.....                                 | 2   |
| 1.4 | Common bridge components.....                         | 4   |
| 1.5 | Design of culverts.....                               | 25  |
| 1.6 | Common culvert components.....                        | 29  |
| 2.0 | COMMON BRIDGE AND CULVERT MATERIALS.....              | 33  |
| 2.1 | Strength of materials.....                            | 33  |
| 2.2 | Concrete.....   | 33  |
| 2.3 | Steel reinforced concrete.....                        | 44  |
| 2.4 | Asphalt.....  | 49  |
| 2.5 | Timber.....   | 49  |
| 2.6 | Soils.....  | 53  |
| 2.7 | Irons and Steels.....                                 | 55  |
| 2.8 | Paints.....   | 69  |
| 3.0 | MAINTENANCE FUNCTIONS.....                            | 71  |
| 3.1 | Inspection, rating, and posting.....                  | 71  |
| 3.2 | Routine maintenance functions.....                    | 73  |
| 3.3 | Periodic maintenance functions.....                   | 73  |
| 3.4 | Major and emergency functions.....                    | 73  |
| 4.0 | SERVICE-RELATED DETERIORATION.....                    | 73  |
| 4.1 | Waterways and terrain.....                            | 74  |
| 4.2 | Substructure problems.....                            | 75  |
| 4.3 | Bridge decks.....                                     | 86  |
| 4.4 | Bridge superstructures.....                           | 88  |
| 4.5 | Culvert maintenance.....                              | 90  |
| 5.0 | PREVENTATIVE MAINTENANCE.....                         | 94  |
| 6.0 | MAJOR REPAIRS.....                                    | 95  |
| 6.1 | Protection against erosion.....                       | 95  |
| 6.2 | Bridge decks.....                                     | 96  |
| 6.3 | Superstructure steel bridge components.....           | 101 |
| 6.4 | Culvert replacement.....                              | 116 |
| 6.5 | Low-cost bridges and water crossings.....             | 119 |
| 6.6 | Worker and motorist safety.....                       | 119 |
| 7.0 | SPECIFICATIONS, STANDARDS, AND CODES.....             | 125 |
| 7.1 | Purposes of specifications, standards, and codes..... | 125 |
| 7.2 | Kentucky Standard Specification Manual.....           | 125 |
| 7.3 | Design codes.....                                     | 126 |
| 7.4 | Workmanship codes.....                                | 126 |
| 7.5 | Material codes.....                                   | 126 |

|     |   |     |
|-----|---|-----|
| 8.0 | BUDGETING AND RESOURCE ALLOCATION.....                    | 127 |
| 8.1 | Replacement and rehabilitation decisions.....             | 127 |
| 8.2 | Role of bridge and culvert inventories and inspections... | 129 |
| 8.3 | Annual budget preparation.....                            | 129 |
| 8.4 | Role of budgeting in planning work.....                   | 130 |
| 8.5 | Contract work versus in-house work.....                   | 130 |
| 8.6 | Determining personnel needs.....                          | 130 |
| 8.7 | Determining equipment and material needs.....             | 131 |
| 8.8 | Some smart moves.....                                     | 131 |
| 9.0 | RECOMMENDED READING.....                                  | 133 |
|     | GLOSSARY.....   | 134 |
|     | APPENDIX.....   | 162 |

# MAINTENANCE OF BRIDGES AND CULVERTS

## 1.0 INTRODUCTION TO BRIDGES AND CULVERTS

Bridge and culvert maintenance is a challenging task for local and county officials. Bridges and culverts are the most expensive portions of the roadways and should be maintained in a safe and economic manner.

Often, a limited budget will cause postponement of some maintenance on roadway structures. However, if one fails to maintain bridges and culverts so that they will not carry vehicles, they will quickly hear from inconvenienced motorists. If the bridges or culverts under one's jurisdiction are not safe, structural failure or some other unfortunate accident may occur with possible injury or loss of life. Work done to maintain safe structures should be completed economically. Inexpensive repairs are usually not durable. On the other hand, unneeded or lavish repairs will quickly deplete an already small budget.

Bridge maintenance requires both experience and good judgment. This manual cannot provide either of those assets. However, it may provide some basis for making decisions that will be useful in the future. Therefore, it is useful to study the manual and to be familiar with portions of it relevant to the local situation.

Bridge maintenance personnel need to communicate with people from many backgrounds: typically, judges, city managers, city councils, mayors, state highway personnel, consulting engineers, lawyers, contractors, land owners, motorists, foremen, and maintenance personnel. A good working knowledge of bridges and culverts will be a definite plus in dealing with those people. Also, it is best to know the correct names of structure types, components, and deficiencies. A good understanding of bridges and culverts will enable bridge maintenance personnel to effectively discuss bridges and culverts with people of many technical and educational backgrounds.

## 1.1 DEFINITIONS

Bridge -- A bridge is a simple span or multiple-span structure having a length of 20 feet or more measured horizontally along the centerline of the roadway between the inside faces of the abutments or end bents at bridge seats, the intrados of arches along the abutment spring lines, or the inside faces of the outer sidewalls.

Culvert -- Structures having a length less than 20 feet typically are considered culverts. Structures longer than 20 feet often are designed both structurally and hydraulically as culverts even though they might be considered bridges. Culverts are usually distinguished from bridges in that culverts generally are covered with an embankment and are composed of structural material for the entire perimeter, whereas a bridge has an open perimeter.

## 1.2 BACKGROUND

Since the 1967 collapse of the Silver Bridge at Point Pleasant, West Virginia, the Federal Highway Administration has begun an inventory to determine the condition of bridge structures throughout the nation. Results have not been encouraging. Of the 563,000 bridges in the US, two-thirds are on secondary and rural roads. About nine out of ten of those bridges were built over 50 years ago. In Kentucky, for example, 53 percent of all bridges are considered structurally deficient or functionally obsolete. Some 5,300 bridges in Kentucky are maintained by local governments.

Those figures become important when considering that long before closing, commerce is disrupted when bridge traffic is limited by posting. One of Kentucky's major industries -- coal -- depends on safe passage over bridges. School buses also must pass over bridges. A bridge load rating must be at least 10 tons before school buses can safely cross them.

## 1.3 TYPES OF BRIDGES

There are many different bridge designs in use today. Many existing bridges, at the time of construction, were considered the best design to meet particular geography, climate, and economic conditions. Since they are still useful, those bridges must be maintained along with the more modern bridges. Therefore, their basic function should be understood.

That task is eased by knowing that all bridges have common basic elements (Figure 1). Those elements are related to the basic purpose of bridges, which is to carry vehicles safely across basins, streams, rivers, other roadways, railroads, etc. The more visible (generally) element of a bridge is the superstructure (including the roadway (deck) and the longitudinal supports (usually girders or trusses) running the length of the roadway to support the deck and vehicles). The bridge also must have supports (substructures) that transmit the loads of the roadway (deck), vehicles, guardrails, and longitudinal supports to the ground.

There are four major bridge types (Figure 2):

1. Simple beam (or span),
2. Continuous beam (or span),
3. Arch, and
4. Suspension span.

The simple-beam bridge is the most common type on county and municipal roads. It is the most economical and simplest type for spanning short distances.

Continuous-beam bridges are rarely encountered on county and local roads. They are usually found on longer spans where extra supports may be easily added.

Arch and suspension bridges are rare in local and municipal governments, though a few suspension bridges are found in Eastern Kentucky.

Before examining bridges in more detail, a basic understanding of the interaction of loads and forces is needed. Loads may be considered as a weight or downward pull of gravity (expressed as pounds).

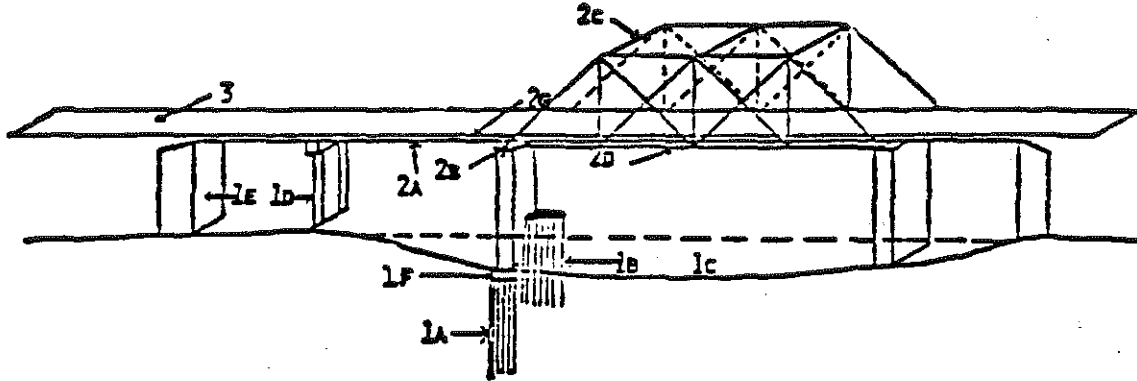

1. Substructure units
  - (a) Piles
  - (b) Scour protection
  - (c) Stream bed
  - (d) Piers
  - (e) Abutments
  - (f) Footings
2. Superstructure units
  - (a) Main supporting members
  - (b) Bearings
  - (c) Secondary members and bracings
  - (d) Utilities
3. Deck including approaches and roadway

Figure 1. Simplified Bridge Showing Basic Elements.

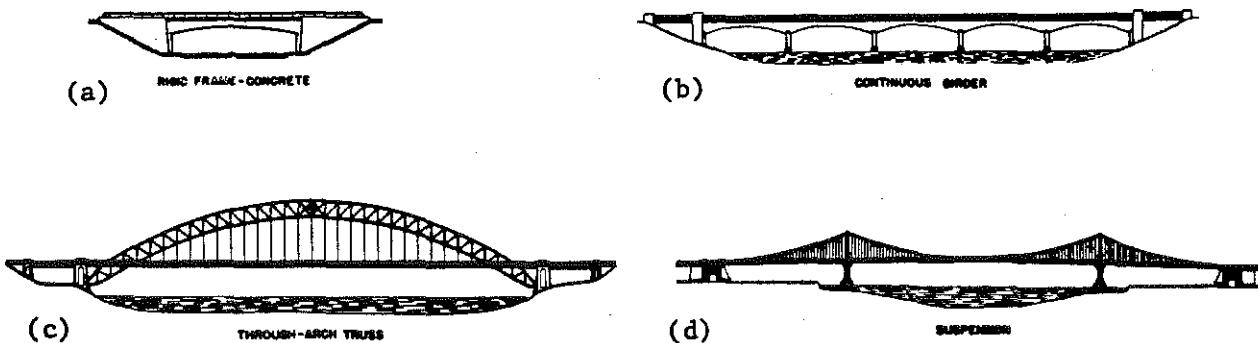

Figure 2. Common Bridge Types.



Three types of loading are encountered on bridges. **DEAD LOADING** is the constant downward "push" of a bridge due to its own weight. This may be the heaviest loading the bridge must support. Varying loads due to the weight of moving traffic are termed **LIVE LOADS**. Wind pressure acts on bridges to produce a **WIND LOAD**. On small bridges, that loading is usually insignificant.

Forces acting in bridge members responding to loads are determined by how the bridge is designed. Members may act in one of three ways: tension, compression, or flexure (Figure 3).

Tensile forces act to pull the ends of a bridge member apart, stretching it. A good example is to pull the ends of a broken rubber band apart.

Compressive forces act to push the ends of a member toward each other, compressing it. A good example would be to compress a coil spring by stepping on it.

Flexure (bending) is a combination of both of those forces. A good example would be to place two saw horses 5 to 10 feet apart and lay a 2x8 flatwise on top of them. By standing on the 2x8, one will feel the plank give or bend downward due to his weight. The top face of the plank is compressed by the flexure, while the bottom face is stretched or tensioned.

Loads produce forces within bridge members. Each member of the bridge is specially designed to bear some of those forces (as long as the loads are within reason). Any event that weakens a bridge member also will reduce the load-carrying capacity of the bridge.

Various materials have different abilities to resist forces. Steel is equally strong in tension and compression. Concrete is strong in compression, but has only nominal strength in tension. Concrete is less expensive than steel and is widely used in many bridge members that support loads in compression. Bridge members that resist flexural loads are often made of two materials, concrete and steel, for example. Concrete sustains loads in the compression portion of the member and steel bears loads in the tensile portion of the member.

## **1.4 COMMON BRIDGE COMPONENTS**

Bridges consist of two major components: the deck system and its support (superstructure) and the substructure.

The deck system consists of 1) road approach slab (sometimes), 2) approach guardrails (sometimes), 3) parapets, and 4) deck (Figure 4).

The roadway approach slab or pavement is important in that it serves as the ramp between the roadway and the bridge deck. Any misalignment between those two should be "smoothed-out" by the approach slab. Usual materials used in this portion of the bridge are either steel-reinforced concrete or asphaltic concrete.

Approach guardrails serve to guide straying vehicles onto the bridge deck. They also are used to prevent impact between vehicles and the parapet ends. Guardrails usually consist of vertical posts driven into the ground for impact resistance. Horizontal rails mounted 1 to 3 feet above the ground contact

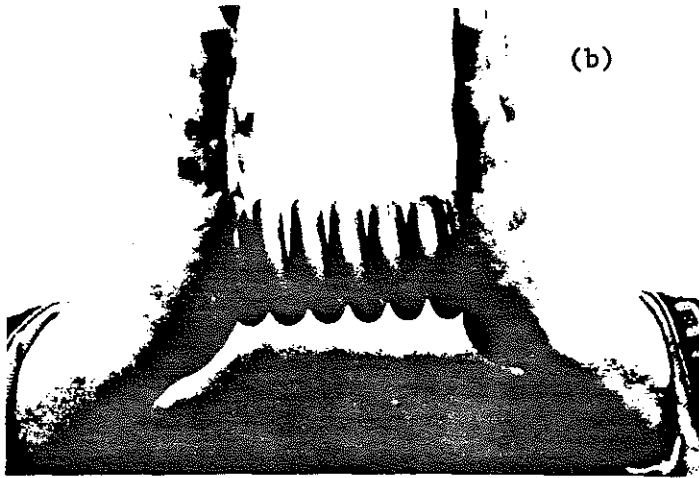
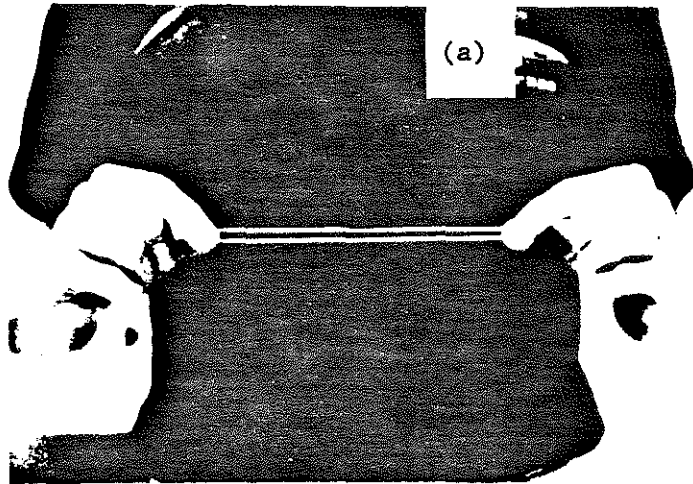

Figure 3. Types of Loads: (a) Tension, (b) Compression, and (c) Flexure.

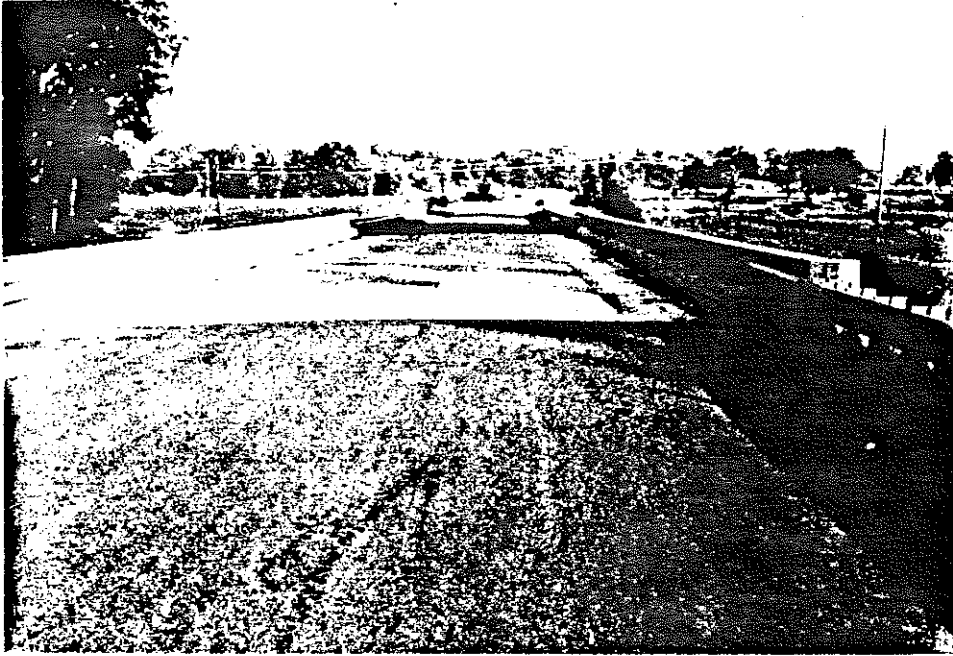

Figure 4. Modern Bridge Deck System.

straying vehicles. Typically, the posts are wood or galvanized steel. The rails are usually made from galvanized steel. Good guardrail designs have the ends exposed to traffic either buried or extended and angled so far from the roadway that wayward vehicles will not impact the guardrail end.

Parapets or bridge deck guardrails are used to keep vehicles on the bridge deck. The most common types of parapets are made from steel-reinforced concrete and are cast or grouted into the bridge deck. Three general types are the conventional post and rail, the curb-type, and the GM or New Jersey Barrier type (Figure 5). The barrier type is the safest and is required on all new or renovated bridges using federal funds.

The metal rail-and-post type of parapet is often similar to those used as bridge approaches (Figure 6). The vertical posts are usually bolted into the bridge deck. The rails and posts are usually made from either galvanized steel or aluminum alloy.

The bridge deck provides a riding surface to support vehicles. The deck has a dual role: to act as a wearing surface and to serve as a structural member. In its first role, the deck must withstand the abrasive effects of vehicle tires, which tends to rut or wear the deck in the wheel paths. Secondly, the deck must be strong enough to bear the flexural forces due to vehicle wheels and pass those forces on to the deck support system.

There are many types of bridge deck systems including 1) steel-reinforced concrete (the most common), 2) steel grid, 3) concrete-filled steel grid, 4) wooden plank, and 5) asphalt-overlaid wood plank.

An integral part of the deck is the bridge drain system. The primary purpose is to remove water from the bridge deck. This eliminates hazards associated with hydroplaning, splash or spray, and icing. The main components are the inlets and drain grates, scuppers, and drain pipes.

Additionally, another element of the deck is the expansion joint used to maintain a uniform driving surface between the deck and the roadway supported by the abutment and/or to seal the substructure and girder or truss ends from water drainage. The simplest and most common types of expansion joints are 1) the sliding-plate, 2) the finger-dam, and 3) the neoprene seal (Figure 7). The sliding-plate and finger-dam types are common on older bridges. The neoprene seal is used in all new concrete-girder bridges. The neoprene shape contracts or expands as required, maintaining a seal within the joint. It is used where very little movement occurs. A fourth type of joint, the modular expansion joint, is made up of a series of neoprene seals. That type of joint is not common.

The deck support system consists of longitudinal and sometimes transverse structural members. They transmit deck loads to the substructure. In most cases, the deck is not sufficiently strong to carry loads without closely spaced support, which must be provided by the structure.

The supports may be transverse to the direction of the roadway, called floor beams or joists, or parallel to the roadway, called stringers (Figure 8). Floor beams must be tied into longitudinal structural elements such as girders. Stringers, however, may run between the substructure elements.

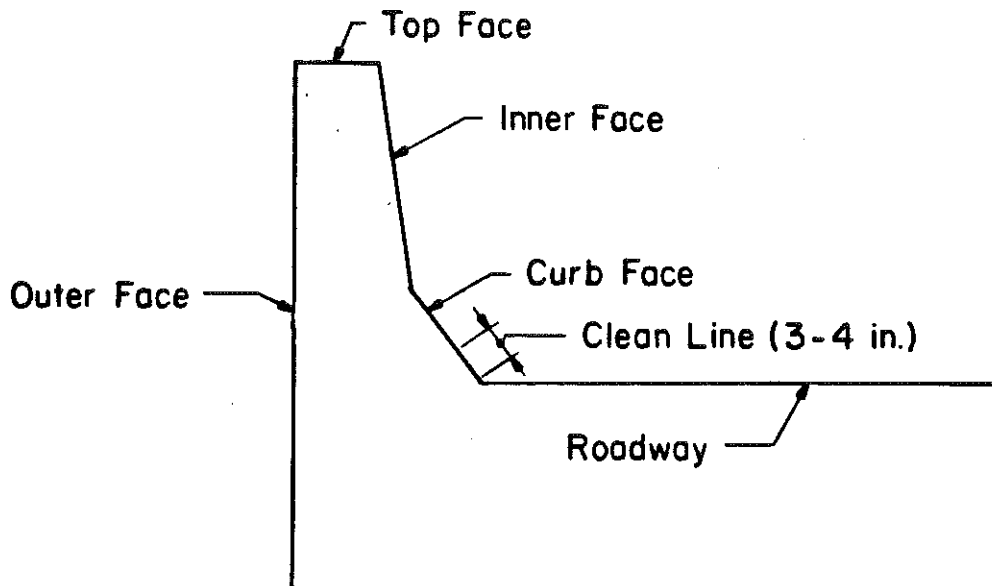

Figure 5. New Jersey (Modern) Parapet.

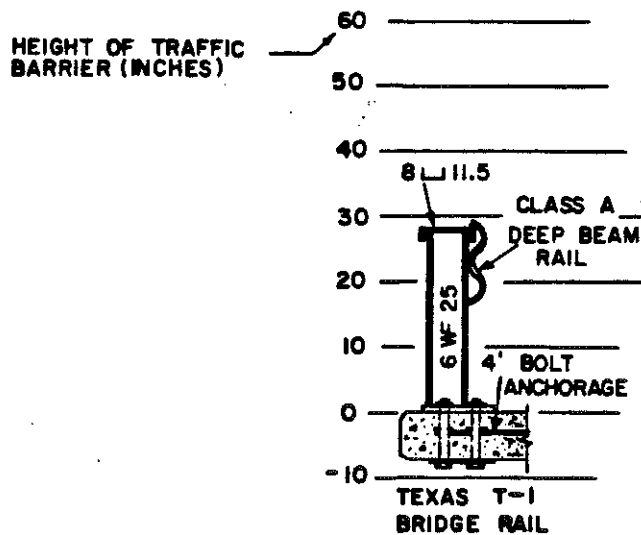
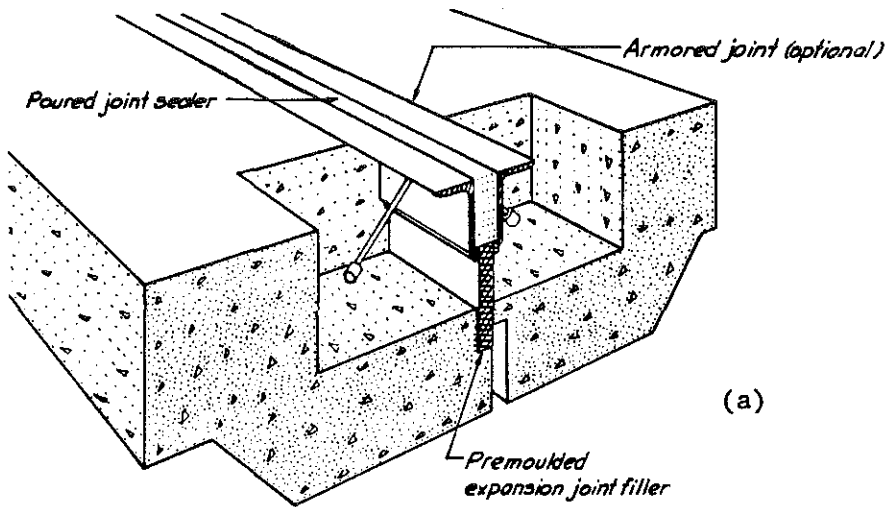
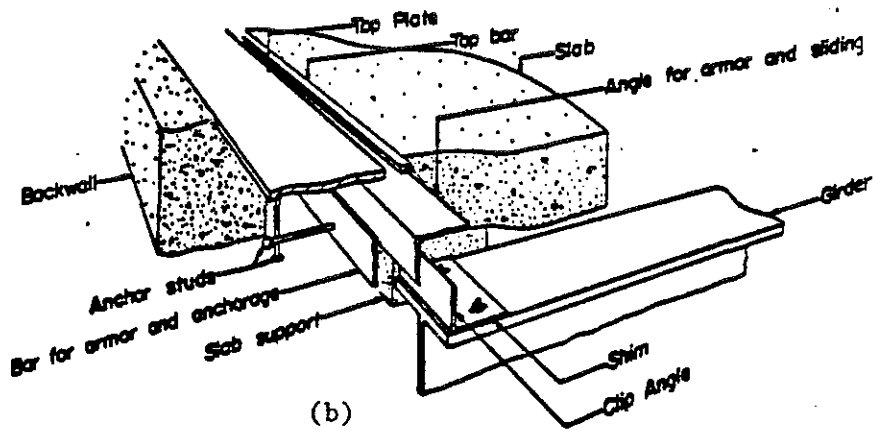

Figure 6. Typical Metal Rail-and-Post Guardrail.



(a)



(b)

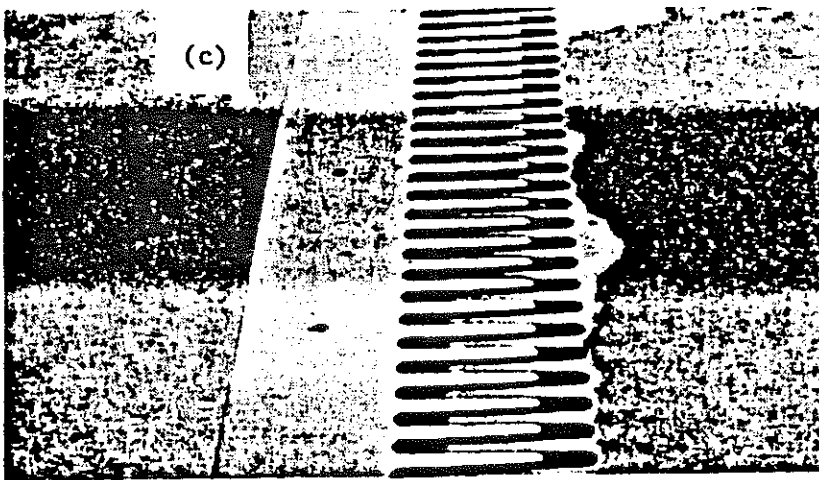

(c)

Figure 7. Common Types of Expansion Joints: (a) Poured Compression Joint, (b) Sliding Plate, and (c) Finger Dam.

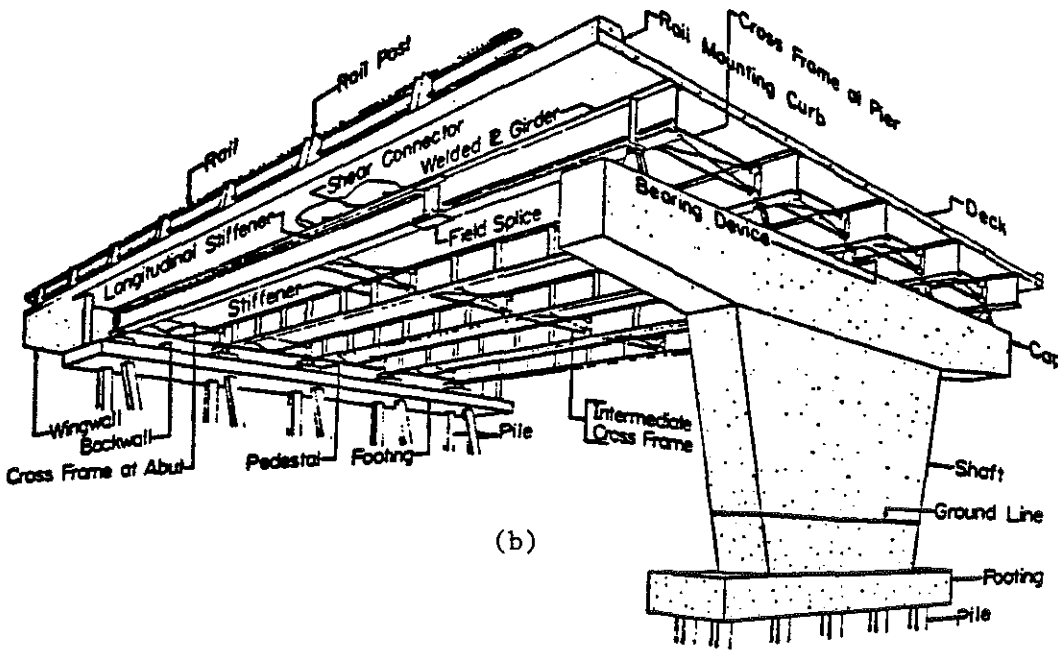
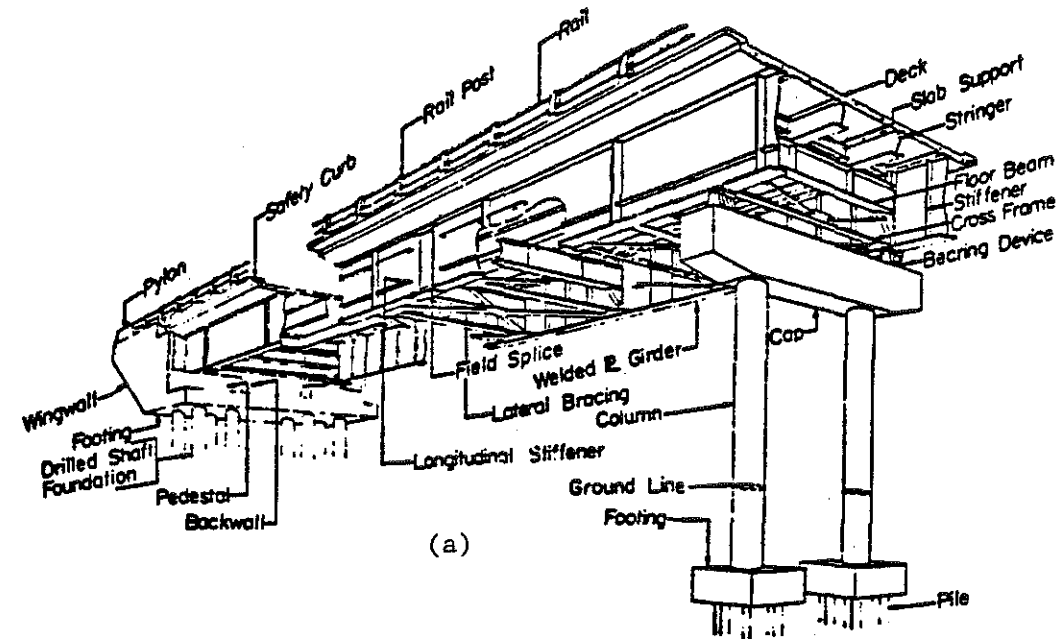

Figure 8. Typical Deck Support Systems.  
 (a) Transverse Floorbeams and Stringers.  
 (b) Longitudinal System (Stringers).

The bridge deck is supported by the longitudinal members (Figure 9). Every bridge has two or more of these supports. Those may be cables on suspension bridges, trusses on truss bridges, and girders or beams on beam bridges. Although these bridges and their longitudinal supports look different, they all perform the same task -- support the deck.

Beams and girders are important since they are the main components of truss and girder bridges. Beams may be made of many materials including wood, wrought iron, steel, and a composite of steel and concrete.

Wooden beams are usually rectangular in section and are either one-piece or a composite of planks glued and/or nailed together.

Early beams and girders made of wrought iron or steel usually were assembled by riveting different shapes of angles and plates together to form the familiar "I" beams commonly seen on metal bridges. The mating shapes had matching holes punched in them and were assembled by inserting red-hot rivets in mating holes and mashing the rivet ends to form heads (Figure 10). That type of construction is time consuming and expensive. A better solution was found for steel with the advent of rolled and welded beams (Figure 11). Riveting is now obsolete.

The combination of steel and concrete led to the development of three different types of composite girders: 1) concrete beams cast with embedded steel reinforcing bars, 2) concrete beams cast with post-tensioned steel wires, and 3) concrete beams cast with embedded prestressed steel wires. The beams come in a variety of cross-sectional shapes including "I" beams, "U" beams, "T" beams, and box beams (Figure 12).

Most rural bridges are simple spans made using either girders or trusses to support the deck. The girders may be either stringers or main girders. Stringers are located under the deck. Main girders are located along the side of the deck above or below the driving surface as shown in Figure 13.

Girders used in those applications are in flexure (bending). A truss is similar in many ways to a girder. However, a truss is made of many interconnected pieces or structural members. A typical truss is shown in Figure 14.

There are many types of truss bridges. Truss bridge designs have been improved over the years. Most early bridges up to the turn of this century were metal trusses. Due to the many separate structural members and various designs, it is difficult to tell which elements are tension members and which ones are compression members (Figure 15). However, there are some easy rules that indicate which members are in tension or compression. Usually the top chord is in compression and the lower chord is in tension (Figure 16). This is similar to flexure in a girder. However, no members of a truss are in flexure. They are either in tension or compression. Also, tension members tend to be simple shapes such as bars or rods. Box members or I beams may be either in compression or tension.

Simple-span truss bridges usually are 35 or more years old. This means that they were probably constructed using pinned, threaded, or riveted connections to hold the structural members together. Since



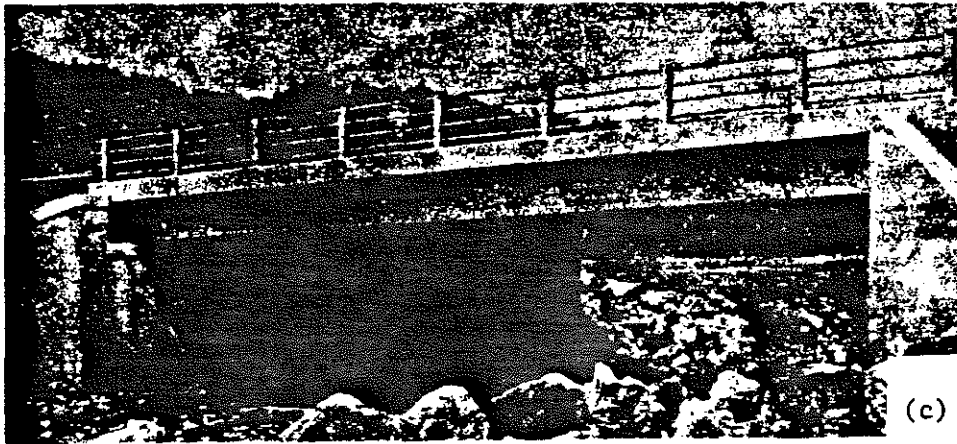
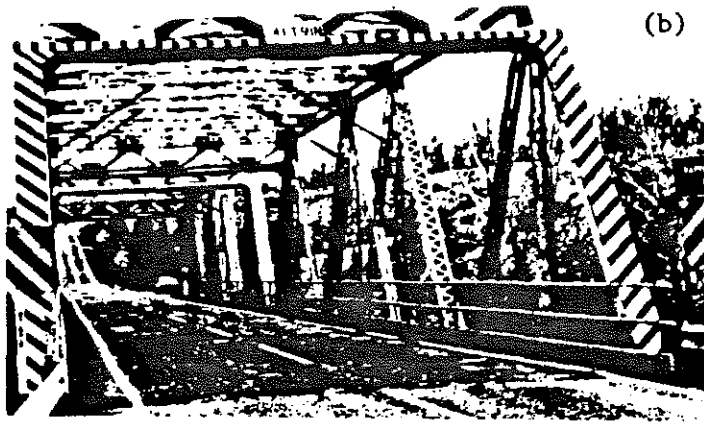

**Figure 9.** Bridges with Different Longitudinal Supports: (a) Suspension Bridge, (b) Truss Bridge, and (c) Girder Bridge.

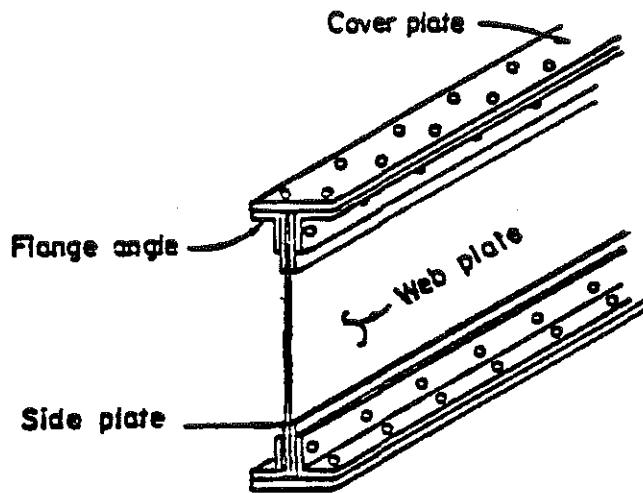
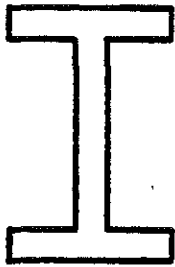
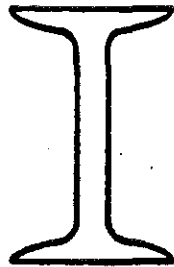

Figure 10. Riveted Girder (Obsolete).



**"W" SHAPE**

**FLANGES HAVE  
CONSTANT THICKNESS**



**"S" SHAPE**

**FLANGES ARE  
TAPERED**

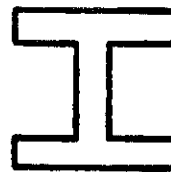

**"HP" SHAPE**

**FLANGES HAVE  
CONSTANT THICKNESS,  
FLANGE WIDTH IS EQUAL  
TO BEAM DEPTH**

Figure 11. Modern Rolled Steel Beams.

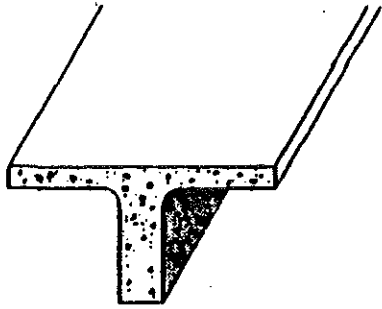

**T-BEAM**

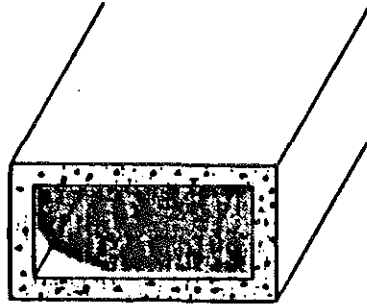

**BOX GIRDER**

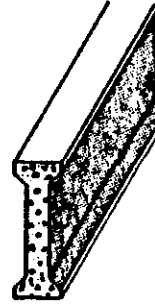

**I-BEAM**

Figure 12. Typical Concrete Girders.

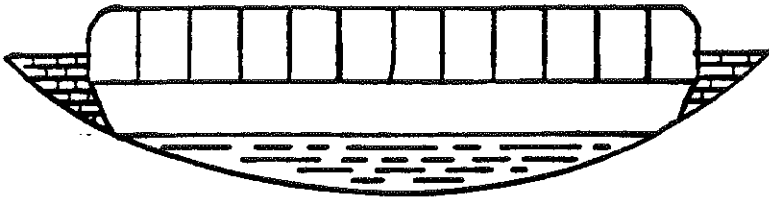

THROUGH GIRDER

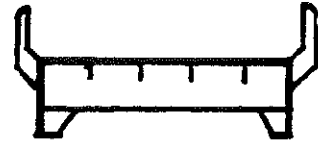
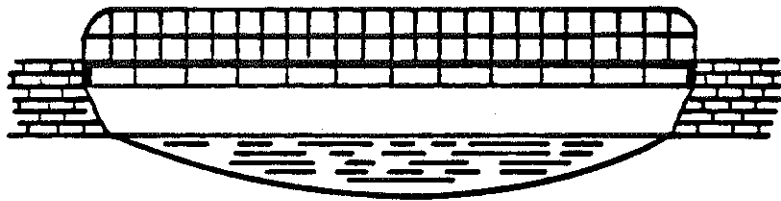

DECK GIRDER

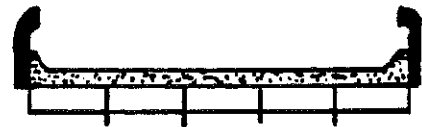
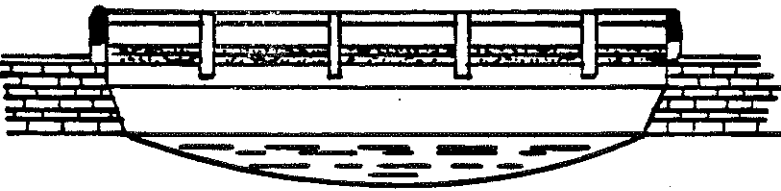

I BEAM

Figure 13. Typical Girder and Beam Bridges.

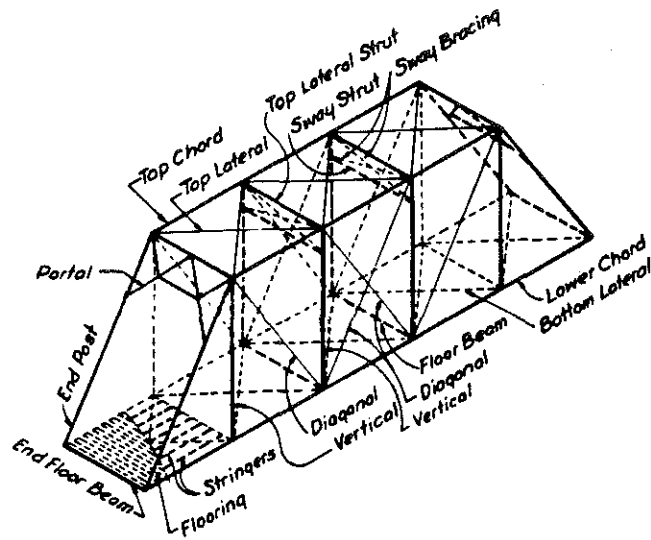

THROUGH HOWE TRUSS

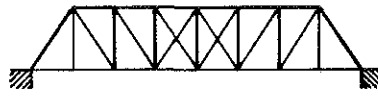

THROUGH PRATT TRUSS

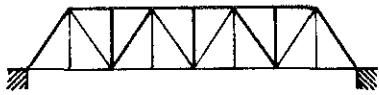

THROUGH WARREN TRUSS

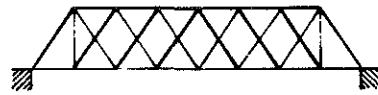

QUADRANGULAR THROUGH WARREN TRUSS

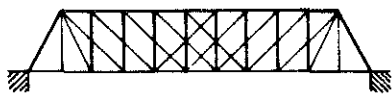

THROUGH WHIPPLE TRUSS



CAMEL BACK TRUSS

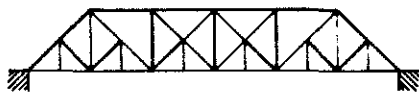

THROUGH BALTIMORE TRUSS

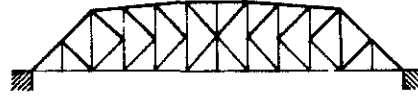

K - TRUSS



THROUGH TRUSS



PONY TRUSS

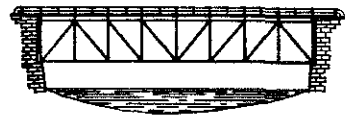

DECK TRUSS

Figure 14. Simple-Span Truss Bridges and Components.

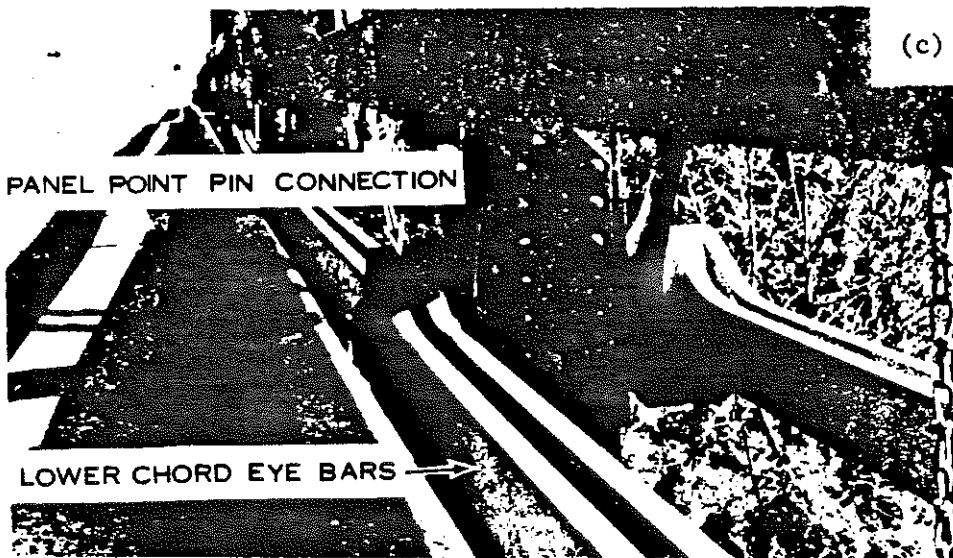
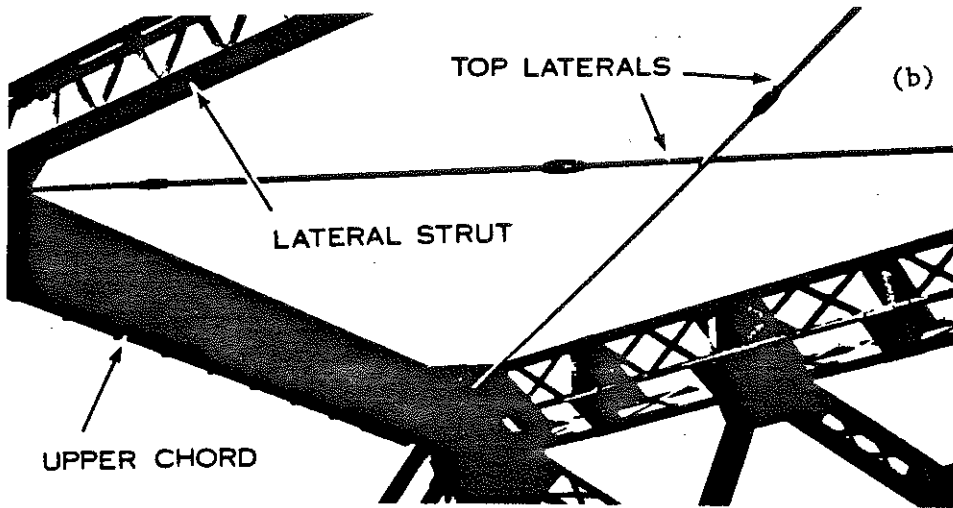
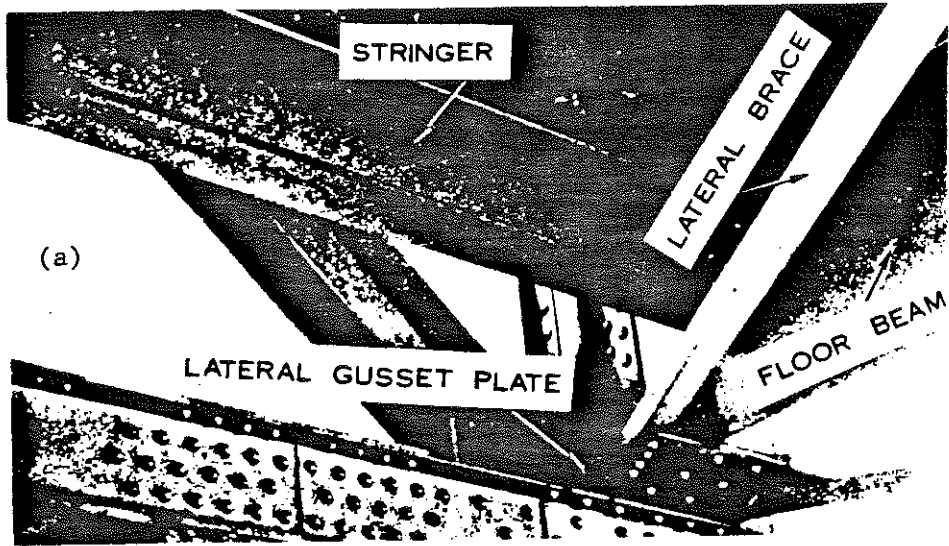
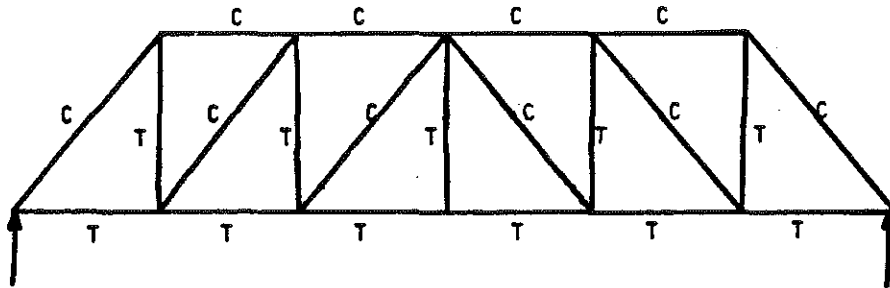
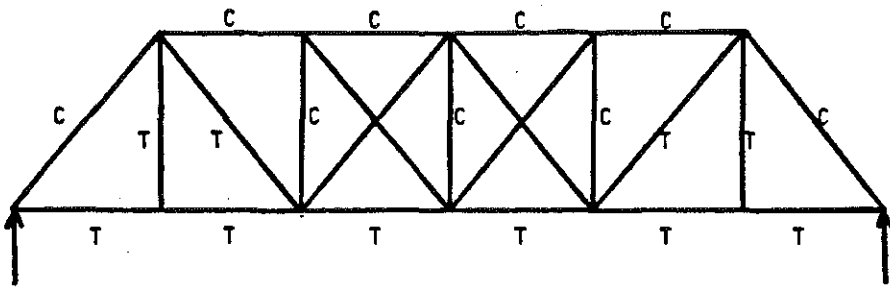

Figure 15. Common Truss Connections: (a) Riveted, (b) Threaded, and (c) Pinned.



THROUGH HOWE



THROUGH PRATT

Figure 16. Compression (C) and Tension (T) Members in Two Types of Simple-Span Truss Bridges: (a) through Howe and (b) through Pratt.

truss bridges are similar in many ways to girders, they may be expected to be arranged similarly to girder bridges.

The substructure must transfer the three bridge loads (live loads from traffic, wind loads, and dead load (or weight of the bridge)) to the ground. In most short bridges, the loads are transferred and the girders or trusses are supported at their ends by substructures. The substructure supports at those points are called abutments (Figure 17a). Structural supports called piers or bents may be located at intermediate points between the abutments on longer bridges (Figure 17b).

Resting on top of abutments and piers of most bridges (except for wooden bridges and some short concrete bridges) are bearing elements that allow the girder or truss to expand or contract along its length due to changes in temperature. The bearing elements may range from simple neoprene rubber pads to complex welded or cast assemblies (Figure 18).

Bearings prevent the longitudinal motion of the expanding/contracting truss or girder from rocking the piers or abutments. Bearings must accommodate this movement by rocking, turning, sliding, or twisting. Rocking or turning is usually accomplished using rockers or rollers. Sliding is provided for through use of bronze bearings. Twisting is provided for through use of neoprene or other elastic-type bearing pads.

The bearings rest on an abutment or pier cap. Often, that cap has a steel plate embedded in it. Most common abutments or pier caps are made of steel-reinforced concrete.

Abutments not only support the bridge superstructure, but they also retain the approach embankment. There are three common types of abutments: full-height, stub, and spill-through or open (Figure 19). Most abutments are constructed of concrete (plain or reinforced). They also are constructed of stone masonry, steel, or timber.

Piers and bents are substructures used to support the bridge at points between the abutments, with a minimum obstruction to flow of traffic or water (Figure 20). Various types of bents and piers are required for different conditions. Functionally, there are no major differences between a pier and bent. A bent is a row of piles rising above the ground and supports a cap. A pier is a column resting on a footing and supports a cap or two or more rows of piles having a common cap.

Piers and bents may be constructed of concrete (plain and reinforced), stone masonry, steel, timber, or a combination of materials. They may be supported on footings or piles.

The pier cap is the topmost portion of the pile or bent and transfers load from the superstructure to the legs or columns of the pier or bent. Pier caps may be reinforced concrete, steel, or wood.

Retaining walls are used to hold back earth or to serve as deflectors of water and debris. Retaining walls may be 1) straight, 2) U-shaped, 3) flared, and 4) curved. Common types of retaining elements are 1) gravity walls, 2) cantilever walls, 3) counterfort walls, 4) bin walls, 5) crib walls, and 6) sheet pile walls.

Gravity, cantilever, and counterfort retaining walls are made from reinforced concrete (Figure 21). Bin walls are a series of bolted bins filled with earth to provide stability. Those may be made from precast



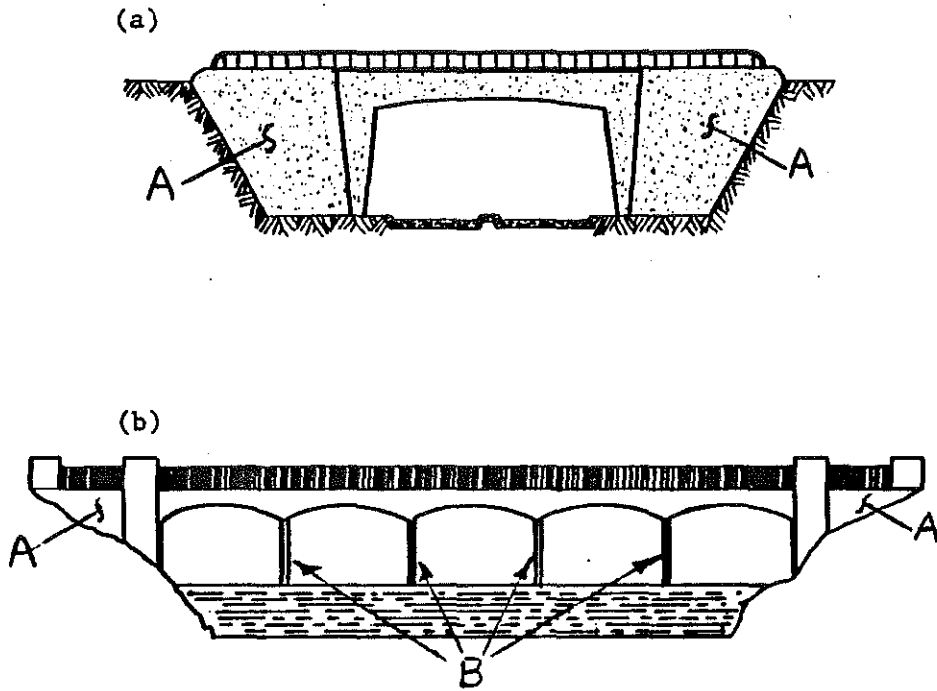
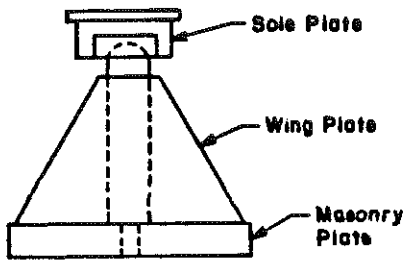
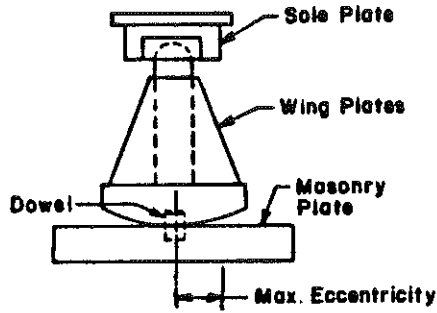

Figure 17. Common Substructure Elements: (a) Simple Span and (b) Multiple Span (A = Abutments and B = Piers or Bents).



FIXED BEARING



EXPANSION BEARING

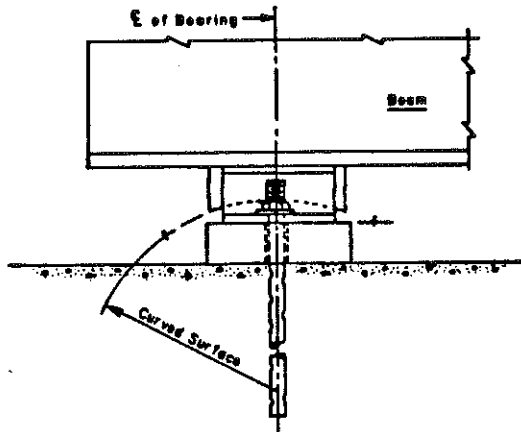

SLIDING EXPANSION BEARING

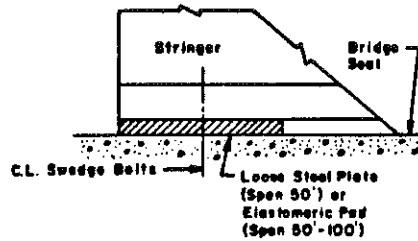

SIMPLE EXPANSION BEARING

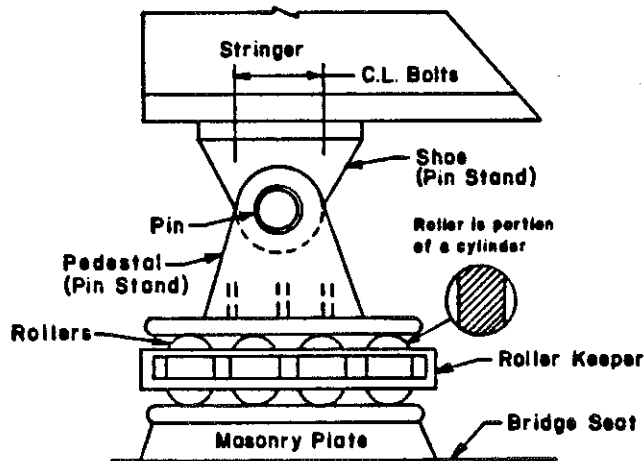

ROLLER EXPANSION BEARING

Figure 18. Common Bearing Devices.

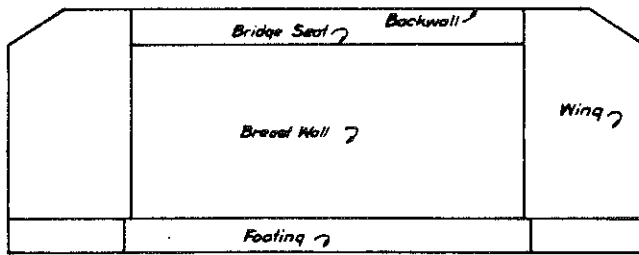

FULL HEIGHT ABUTMENT

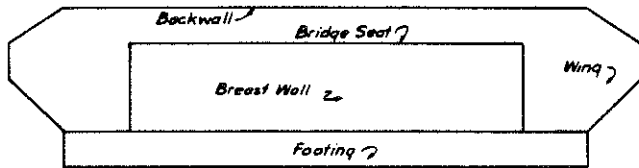
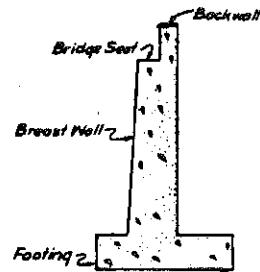

STUB ABUTMENT

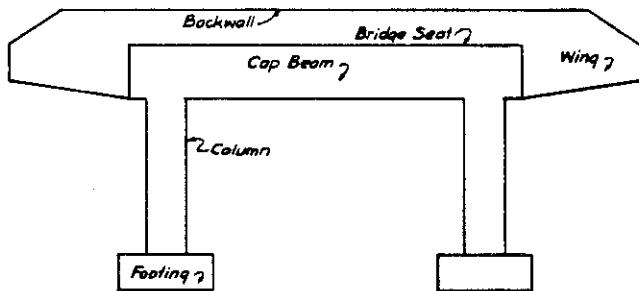
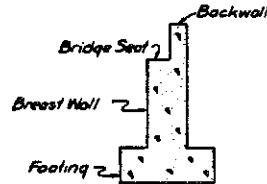

OPEN ABUTMENT

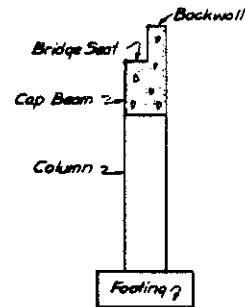
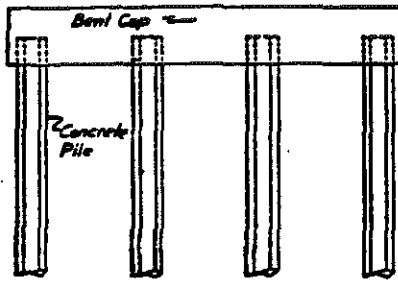
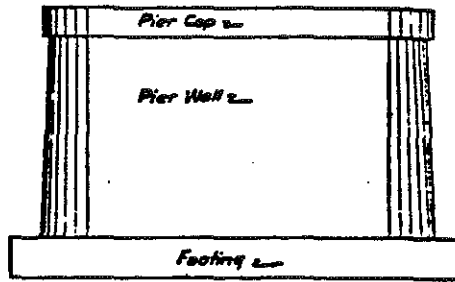

Figure 19. Common Types of Abutments.



PILE BENT



SOLID PIER

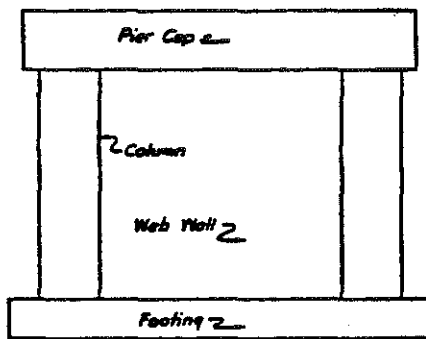

COLUMN PIER WITH SOLID WEB WALL

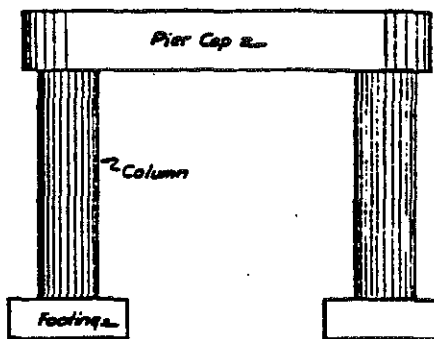

OPEN PIER

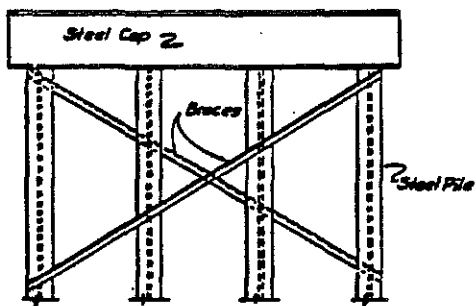

STEEL BENT

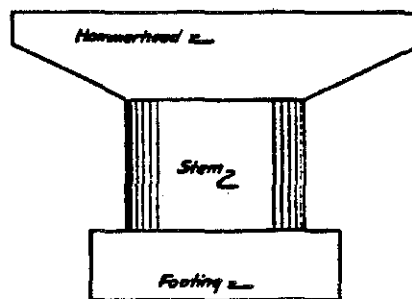

CANTILEVER PIER OR HAMMERHEAD PIER

Figure 20. Typical Piers and Bents.

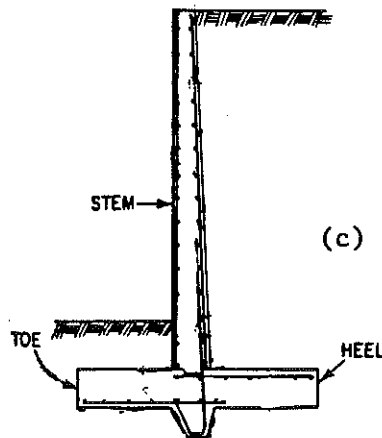
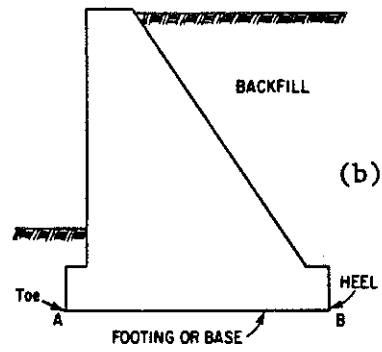
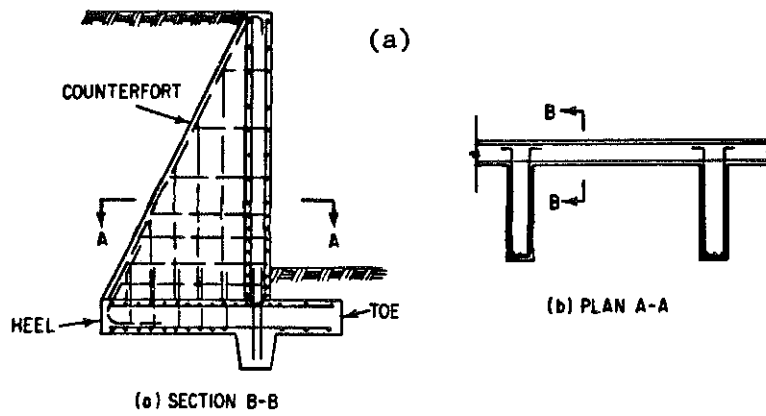

Figure 21. Types of Retaining Walls: (a) Counterfort, (b) Gravity, and (c) Cantilever.

concrete, timber, or steel. Crib walls are overlapping members at the corners. The open-like compartments are filled with earth similar to bin walls. Those may be constructed with precast concrete, timber, or steel. Sheet pile walls consist of steel, concrete, or timber sheet piling driven to a suitable depth.

The land and possibly the waterway in the area of the bridge affect not only the span of the bridge but also its design and that of its major components. Main geographic components are the approach, embankment, and waterway or chasm.

Curbs and sidewalls are sometimes part of a bridge deck. Curbs are parallel to the side limit of the roadway to guide the movement of the vehicle wheels and safeguard bridge trusses, railings, and other constructions outside the roadway limits. Curbs also may provide some protection to pedestrians on the sidewalks. Curbs may be constructed of stone, concrete, steel, or timber.

Sidewalks are the portion of the bridge floor area serving pedestrian traffic only and are for the safety and convenience to its users.

Accessory elements to the bridge include signing, lighting, and utilities. Signs warn of predetermined hazardous conditions relative to the traffic and bridge structure. Typical signs inform travelers about weight limits, bridge clearances, and vehicle speeds. Weight-limit signs should be placed just before the bridge on the shoulder of the road. Vertical clearance signs should be painted on the bridge superstructure or on a sign attached thereto. Regulatory signs (of traffic laws or regulations) are colored black on white. Warning signs normally are black on yellow, calling attention to conditions on or near the bridge. Guide signs provide nice-to-know information such as routes and directions. Other signing includes bridge-end markers, reflector-type markers, painted pavement marking, and raised markers.

Lighting includes highway, signing, traffic control, and waterway navigation elements. Lighting usually consists of a luminaire that houses the lamp, a bracket arm to support the luminaire, a shaft or pole to elevate the luminaire, and an anchor base that connects and holds the shaft to the foundation.

Utilities are public services that include gas, water, electric, telephone, and sewer. Usually, utilities may obtain legal permission to use bridges to span chasms as long as placement of the utility (usually a pipe or conduit) does not constitute a hazard.

## **1.5 DESIGN OF CULVERTS**

### ***1.5.1 Shapes of Culvert***

The shape of a culvert frequently is chosen for reasons of headroom or strength rather than for hydraulic concerns. Single culvert openings are generally more satisfactory because of a greater ability to handle floating debris and driftwood than multiple culverts with smaller openings.

Selection of a culvert type and shape is based on construction cost, structural adequacy, durability, potential for clogging by debris, limitations on headwater elevation, embankment height, and hydraulic performance.

Commonly used culvert shapes (Figure 22) are circular, pipe arch, elliptical, box or rectangular, arch, and multiple barrels.

The circular cross section is the most commonly used shape. The circular shape is structurally efficient under most loading conditions, typically readily available, simple to install, and generally provides good hydraulic performance under most applications.

Pipe arch culverts typically are used in lieu of circular culverts for those situations where the embankment or overburden are limited. A pipe arch will provide for greater water flow at depths up to half full than a circular culvert with the same area of opening. Pipe arch culverts provide for greater water flow at lower surface elevations than do circular pipes. This is advantageous for those situations where there is very little room for cover or backfill over the pipe.

Elliptical culverts often are used for pedestrian walkthroughs or for cattle crossings. Elliptical culverts are subject to the same clogging problems as circular culverts. Elliptical culverts may be constructed of either steel or concrete. With thick overburden, the major axis (longest axis) of the elliptical shape for steel culverts must be laid in the vertical plane. There is no such restriction for concrete elliptically shaped culverts. When the major axis is horizontal, less embankment (fill) is required and flow is greater with less head.

Rectangular or box culverts can be designed to fit almost any site condition. Rectangular cross sections are adaptable since the height and span may be varied to meet almost any site condition. Rectangular or box culverts are generally concrete and either may be poured in place or precast. Precast culverts eliminate long construction periods related to forming and curing.

Arch culverts on concrete abutments should be used only where there is adequate foundation support. Arch culverts offer less obstruction to the waterway than pipe arches. The natural stream bottom is maintained and may be beneficial for some species of fish. However, the potential for scour and erosion in the natural stream bottom is a severe limitation that must be evaluated carefully.

Culverts having more than one barrel, opening, or channel are useful in waterways where the concentration of flow must be kept to a minimum. Low roadway embankments, flood flow distribution, and channel deposition are factors that might influence the use of multiple barrels. Multiple barrels do have the tendency to catch debris and are susceptible to the deposition of silt and sedimentation. Ice jams also may be a problem.

### ***1.5.2 Hydraulic and Hydrologic Considerations***

The objective of hydraulic analyses is to determine the kind, proper size, shape, alignment, slope, and end treatment of a culvert to handle the quantity of flow and debris with minimum or no damage to the embankment, culvert structure, and property above and below the site of the culvert. Estimation of the maximum flood to be handled safely and economically by the structure is a hydrologic consideration. Factors affecting the flood flow quantities include the watershed characteristics, the time of

| SHAPE   | RANGE OF SIZES   | COMMON USES  |
|---|--|--|
| <b>ROUND</b>   | 6 in. to 21 ft   | Culverts, subdrains, sewers, service tunnels, etc. All plates same radius. For medium and high fills (or trenches)   |
| <b>VERTICALLY-ELONGATED (ELLIPSE)</b><br>8% IS COMMON  | 4 ft to 21 ft nominal; before elongating                             | Culverts, sewers, service tunnels, recovery tunnels. Plates of varying radii; Shop fabrication. For appearance and where backfill compaction is only moderate. |
| <b>PIPE-ARCH</b>                                      | span x rise<br>18 in. x 11 in.<br>to<br>20 ft 7 in. x<br>13 ft 2 in. | Where headroom is limited. has hydraulic advantages. Corner plate radius. 18 inches or 31 inches for structural plate.   |
| <b>UNDERPASS</b>                                     | 5 ft 8 in. x<br>5 ft 9 in.<br>to<br>20 ft 4 in. x<br>17 ft 10 in.    | For pedestrians, livestock or vehicles (structural Plate).   |
| <b>ARCH</b>    | 6 ft to 25 ft  | For low clearance large waterway opening, and aesthetic (structure; plate).  |

Figure 22. Shapes and Uses of Corrugated Conduits.



concentration of rainfall runoff, and the drainage area. Watershed characteristics are related to the area, slope, shape, vegetation, soil permeability, and number of drainage channels. The time of concentration is the time required for runoff from the most remote part of the drainage area to reach the culvert. Other factors relating to runoff analyses include effects on fish and wildlife, sources and types of potential debris, effects on other structures, and effects on land use within the watershed.

### **1.5.3 Structural Considerations**

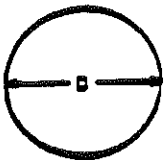
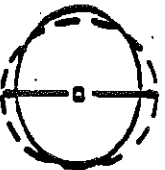
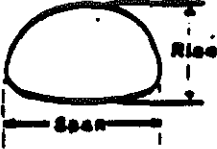
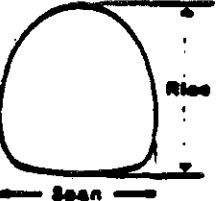
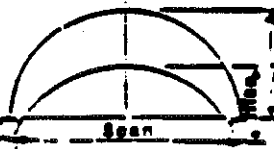
As with bridges, a culvert must be strong enough to support the heavy loads associated with the overburden or embankment and also the loads associated with the traffic using the roadway above. Two types of loads are present. The embankment load is "static" or relatively constant and is always present. The traffic load is "dynamic" since it varies with time, dependent upon the size and speed of the vehicles passing over the structure. The ability of the culvert to support these loadings is dependent upon the strength of materials, design of the structure, and quality of construction of the structure, bedding, and backfill.

### **1.5.4 Location of a Culvert**

Ideally, a culvert should be located in the natural stream channel. The stream bed offers the best hydraulic alignment (the natural flowline) and requires little channel work or excavation. The most important factor in the location of a culvert is to insure the culvert will carry the water adequately under the embankment. Improper alignment may result in erosion of the embankment at the headwall and inlet.

Other factors affecting the location of a culvert include the weight of the surface load the culvert will have to support, the height of the embankment over the culvert, and the foundation conditions at the site. These are structural considerations.

### **1.5.5 Size of a Culvert**

There are several factors affecting the size of a culvert, including the slope of the barrel, the slope of the stream profile, the velocity of flow, the headwater and tail water, and the roughness of the interior walls of the culvert. Culvert sizes may be determined by inlet control or outlet control. Under inlet control, the primary influencing factors are the cross-sectional area of the barrel, the inlet configuration, and the headwater or ponding. Under outlet control, the primary influencing factors are the tail water in the outlet channel and the slope, length, and roughness of the culvert barrel.

### **1.5.6 Materials**

Selection of materials for culvert construction is dependent upon such factors as durability, strength, flow characteristics, wear resistance, bedding conditions, and water tightness. The more common materials are concrete (either reinforced or nonreinforced, dependent upon specific structural requirements), corrugated steel, and corrugated aluminum.

## 1.6 COMMON CULVERT COMPONENTS

The culvert inlet collects the flow of water upstream and directs that flow into the throat or barrel of the culvert. The specific shape and design of the inlet is a function of the shape of the culvert opening and specific site conditions (Figures 23, 24, and 25). Factors affecting the configuration (geometry) of the inlet are the cross-sectional area requirements and the headwater or ponding that affects the potential for deposition of silt and sedimentation upstream.

The culvert barrel transfers the flow of water from the inlet upstream to the outlet downstream. The size of the opening is a function of the hydrologic and hydraulic requirements. The shape of the barrel opening is related to construction costs, structural requirements, durability, potential for clogging by debris, limitation on headwater elevation, height of the embankment or fill, and the hydraulic performance of the design. The slope of the barrel is primarily a hydraulic consideration relating to the slope of the stream profile, velocity (speed) of flow, depth of headwater and tail water, and roughness of the interior walls.

The outlet of a culvert transfers the flow of water from the barrel downstream to the opposite side of the embankment. The design of the outlet is a function of the velocity of flow at the outlet (and all factors affecting the velocity of flow through the culvert barrel), length of the culvert barrel, depth of tail water, and potential for erosion downstream.

Another culvert component includes debris barriers, which may be located at or near the inlet. Debris may be handled by intercepting (blocking) the debris at or above the inlet, deflecting the debris for detention near the inlet, and/or passing the debris through the structure. Culverts with high discharge velocities are subject to erosion downstream, thereby requiring armour (protective devices) and energy dissipators (devices to slow the speed of flow).

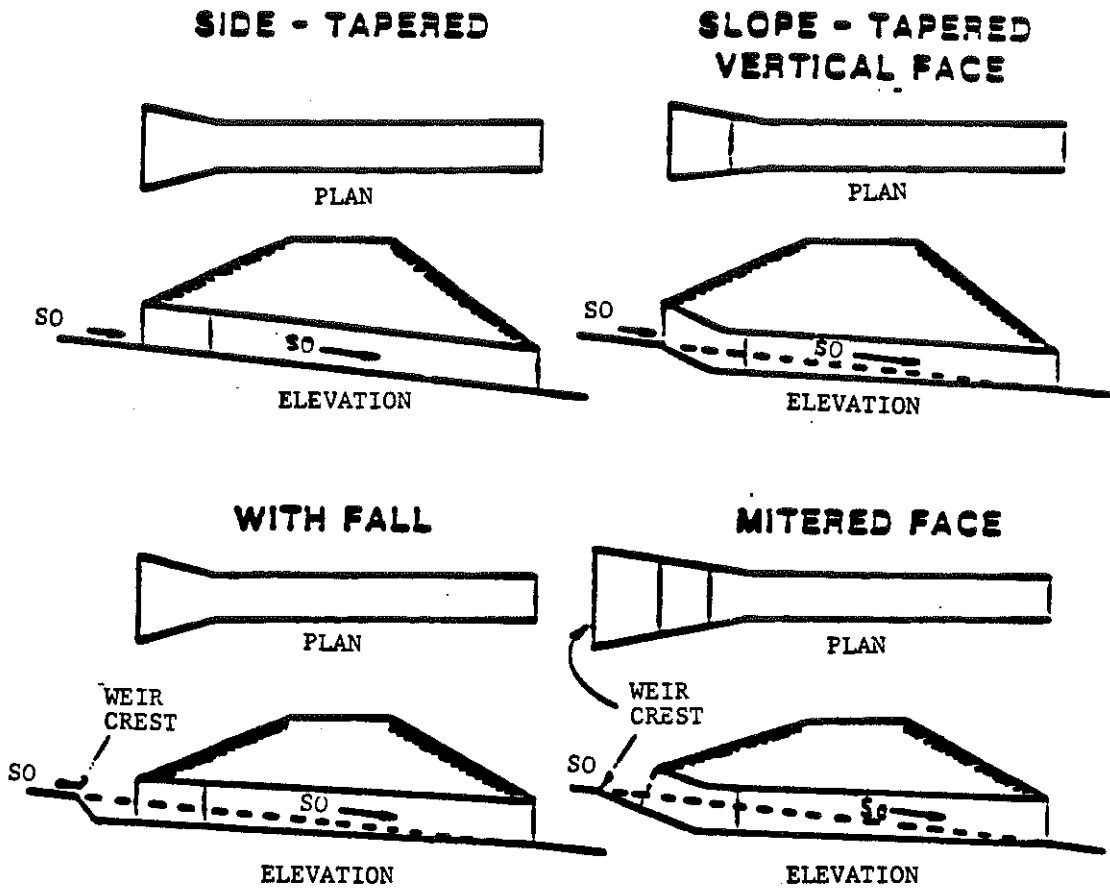
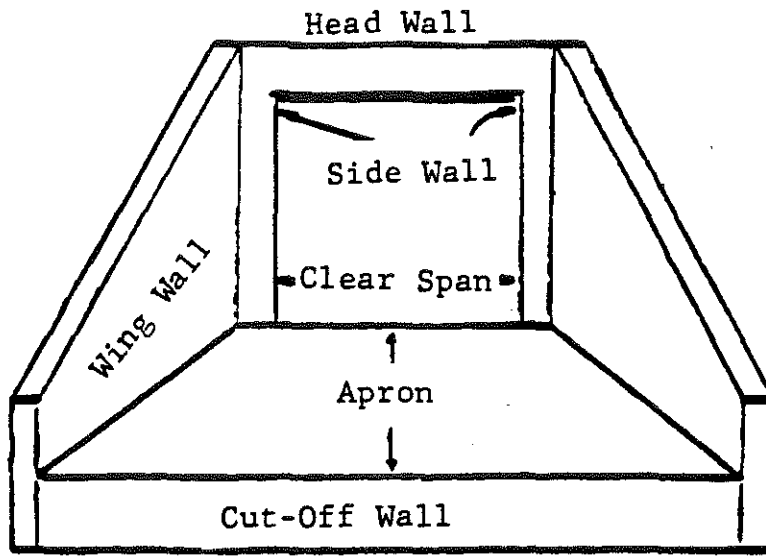
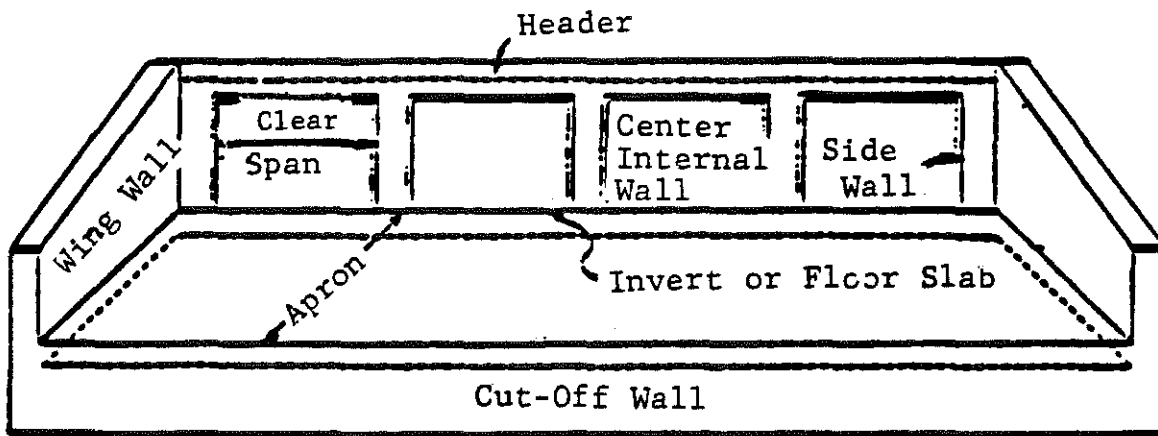

Figure 23. Improved Inlets for Box Culverts.



**SINGLE BOX CULVERT**



**MULTIPLE BOX CULVERT**

Figure 24. Typical Features of Box Culverts.

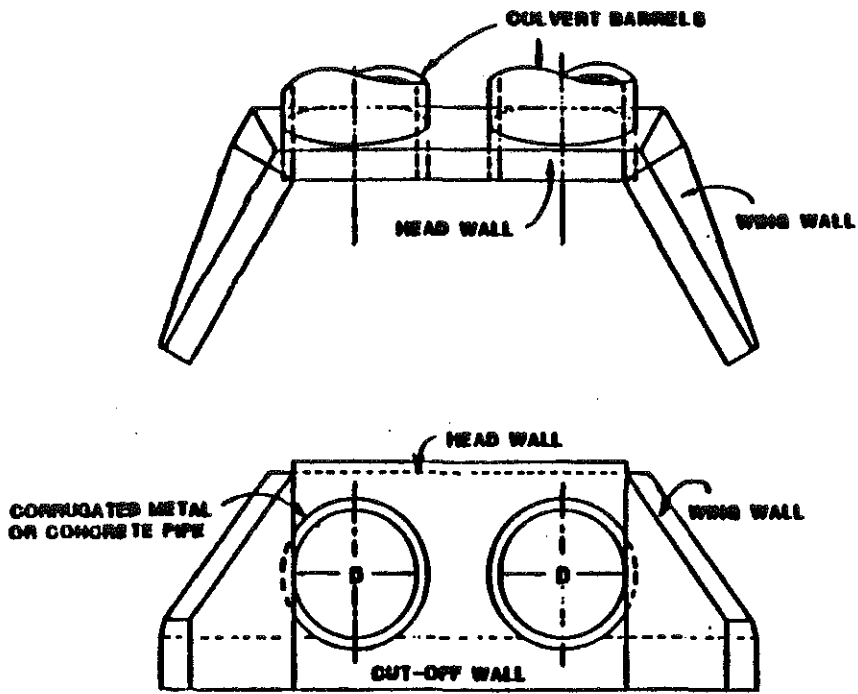

Figure 25. Multiple-Barrel Culverts.

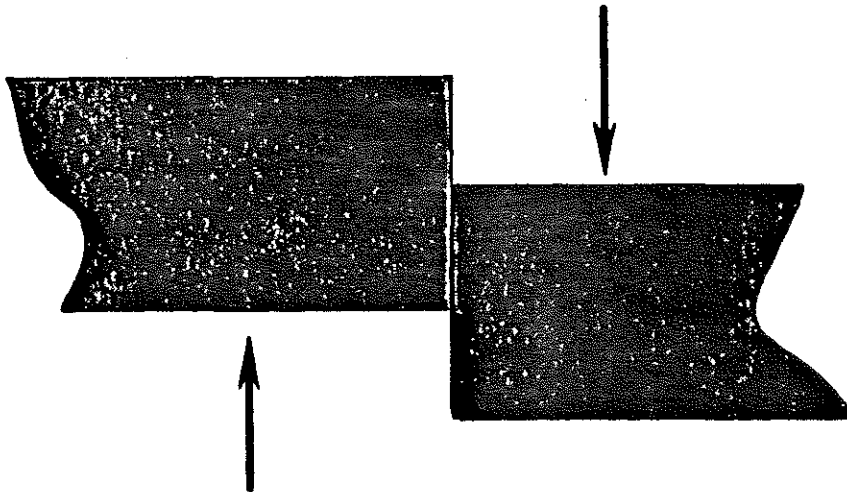

Figure 26. Example of Shear.

## 2.0 COMMON BRIDGE AND CULVERT MATERIALS

Most bridge and culvert materials have been selected because they were strong, durable, and relatively inexpensive. Also, they must be readily formed into usable shapes. The most common materials are 1) concrete, 2) steel, 3) wood, 4) asphalt, 5) stone masonry, 6) soils, and 7) paints. Other materials including copper, lead, rubber, glass, cork, and plastic may be used in small amounts in bridges and culverts.

### 2.1 STRENGTH OF MATERIALS

Before discussing the common materials, an explanation of how materials react to loads will be attempted. As previously stated, most bridge loadings induce tension, compression, and flexure. Materials will react to those loadings in several ways. They will elongate, compress, bend, shear, buckle, or crack.

Extension, compression, and bending have been discussed earlier. Shear is the sliding of one part of a material past an adjacent part when it is acted upon by two parallel forces having opposite directions (Figure 26). Shear also is produced by bending. Buckling is a crushing type failure produced by bending or compression. Stepping on a beverage can will cause the sides of the can to bend and crush as the ends of the can are pushed together (Figure 27). Bending copper tubing will cause the inside to wrinkle, which is a buckle.

Cracking is separation of a material partially or completely by breaking bonds within the material. Cracking is usually associated with tension or flexural loads. Tearing a sheet of paper or bending a pencil until it breaks are two examples of cracking (Figure 28).

Various materials act differently when loaded similarly. For instance, some materials may be compressed but may not be tensioned and vice versa (Figure 29). This is because of the inherent nature of the material. A soil typically cannot be loaded in tension. It will crack. Most materials can be loaded in compression. When concrete is overloaded in compression, it will crack. When steel is overloaded in compression, it will buckle or shear. A soil overloaded in compression will shear.

### 2.2 CONCRETE

Concrete is composed of two basic elements: aggregate (rock) and cement paste. The aggregate accounts for about 60 to 80 percent of the volume of a concrete mixture and are grouped into two basic categories: coarse aggregates and fine aggregates. Coarse aggregates typically make up about 70 percent of the volume of the concrete mixture (Figure 30). The remaining volume consists of fine aggregate (usually sand), cement, water, and entrained air. Specific proportions may vary, depending upon the characteristics of the aggregate and cement used.

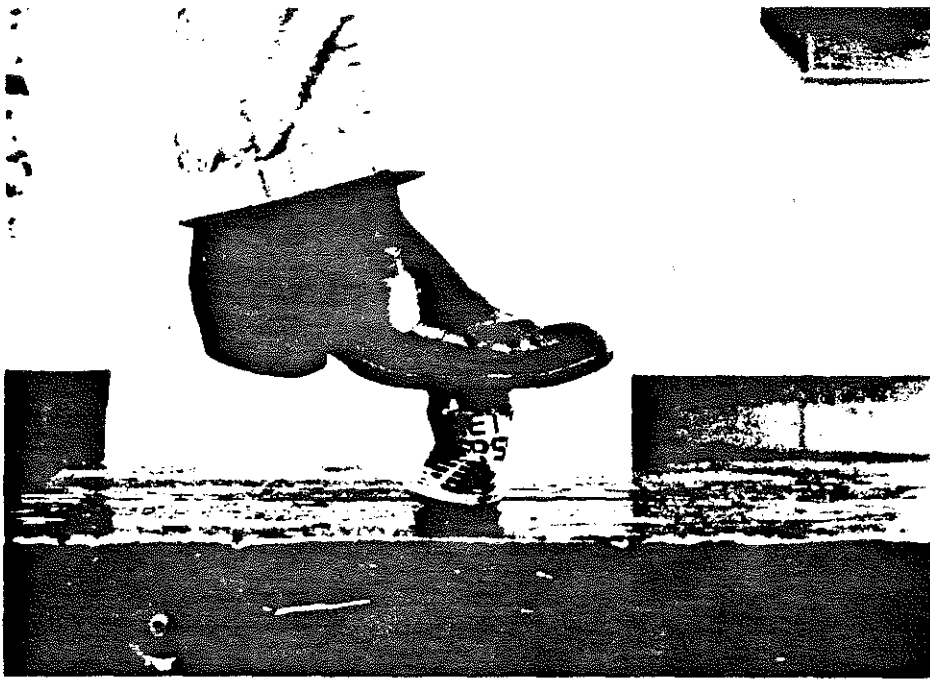

Figure 27. Buckling Caused by Compression.

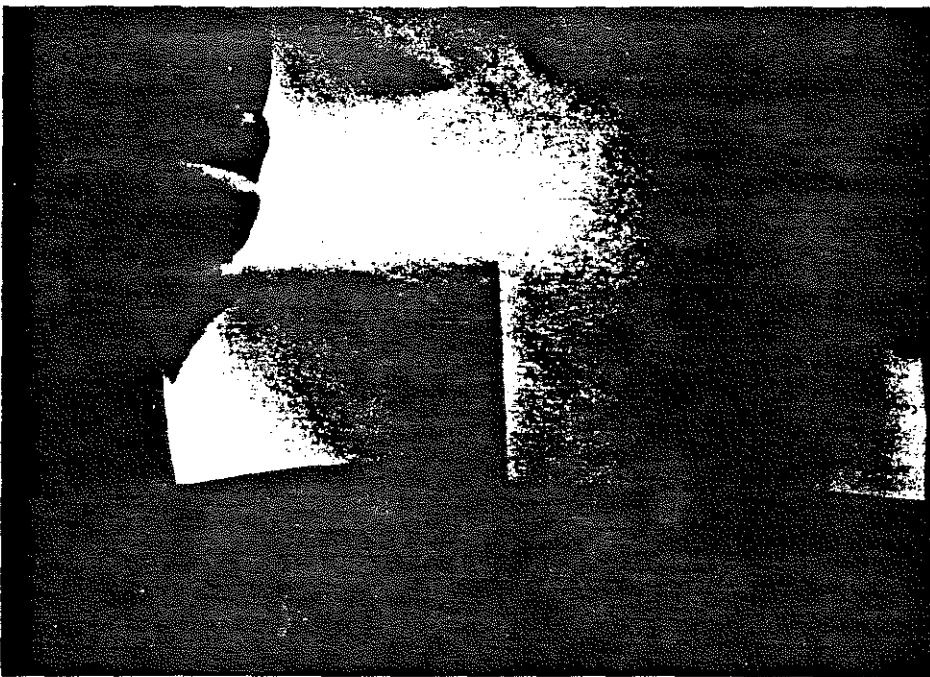
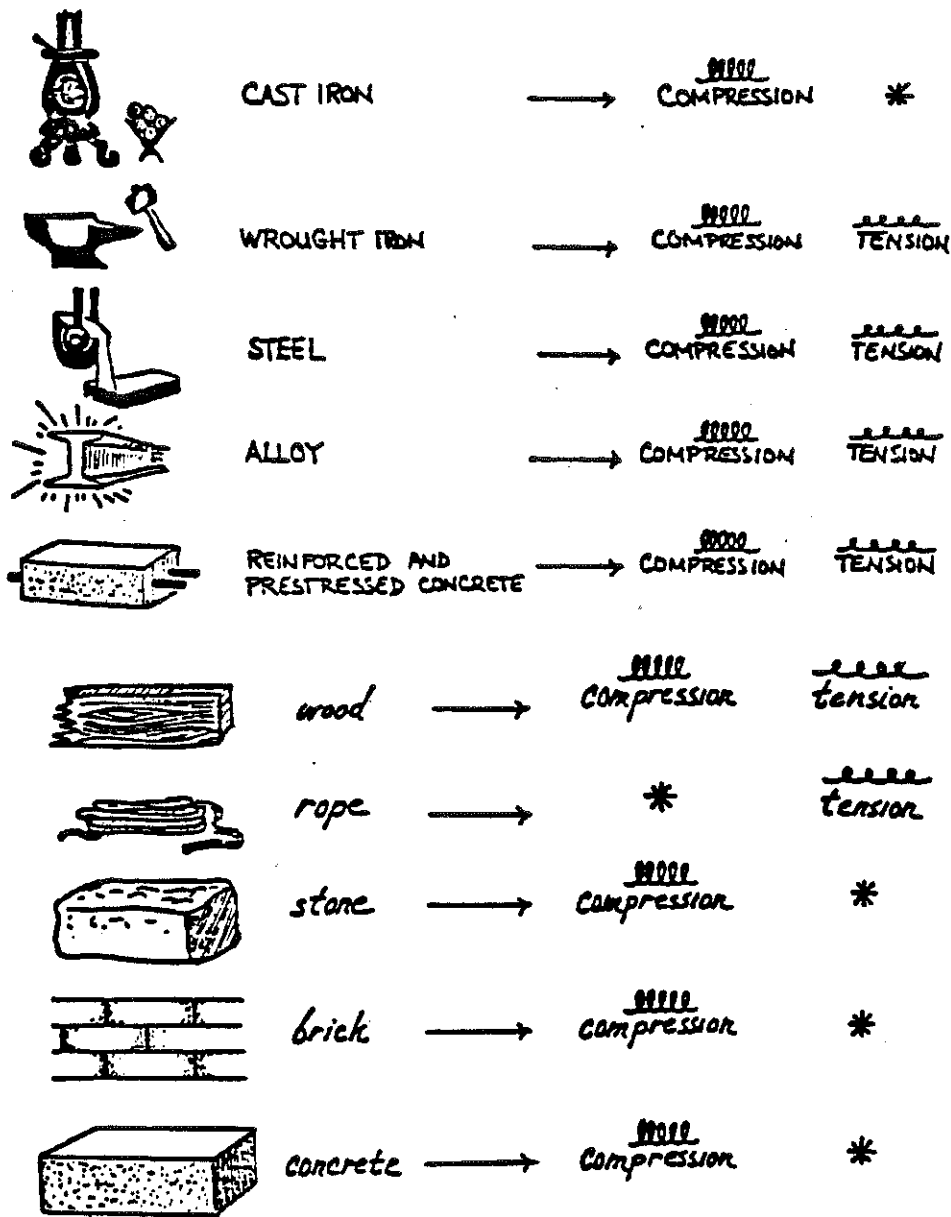

Figure 28. Example of Cracking.



\* Not usable for this type of loading.

Figure 29. Materials Used to Resist Compression and Tension.



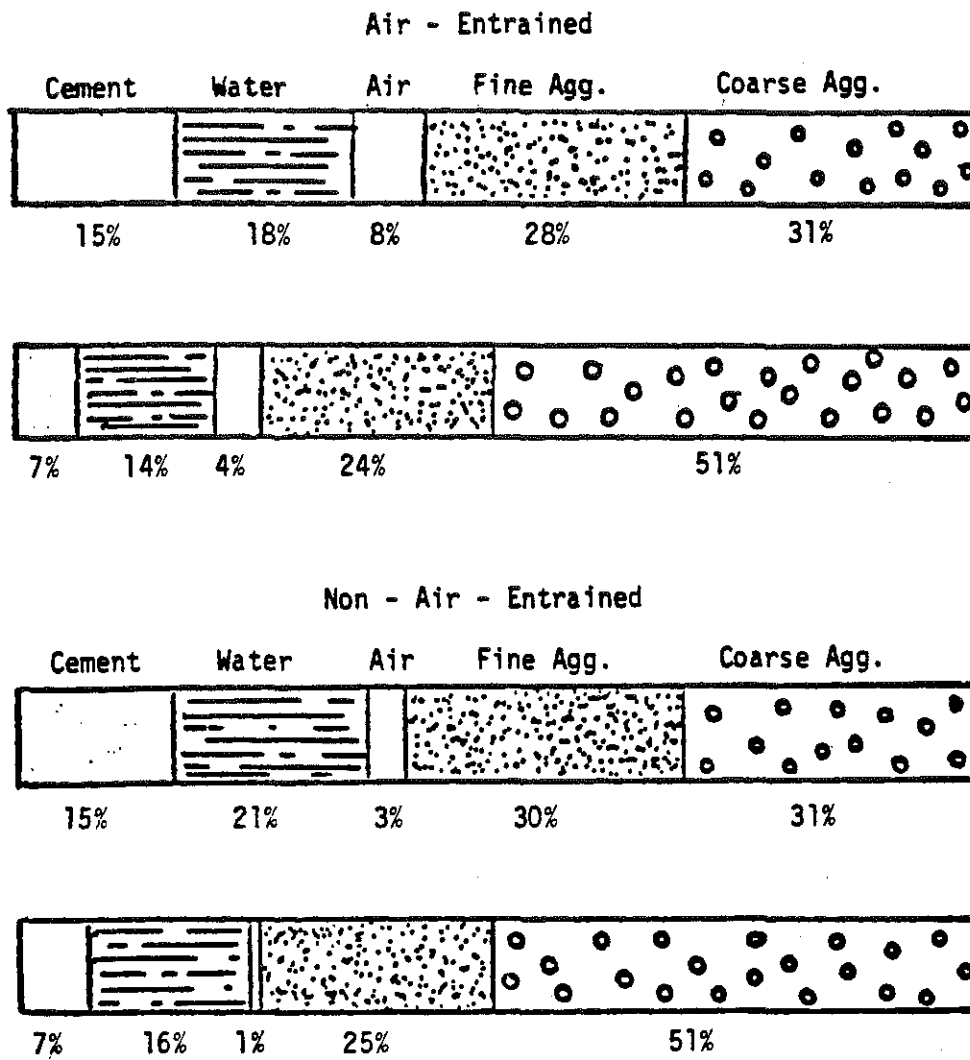

Figure 30. Components of Concrete Mixtures.

### **2.2.1 Quality of Concrete Mixtures**

A concrete mixture should be durable as well as workable, which involves the ease of placing, handling, and finishing the mixture. It should be weather resistant to avoid deterioration caused by freezing and thawing, or wetting and drying, or heating and cooling. It also should be resistant to erosion caused by water flow, traffic, and wind, as well as resistant to chemical deterioration caused by deicing salts, salt water, and sulfate salts.

In addition, concrete mixtures should be watertight and exhibit high strength. Other considerations are economy of materials, blending, and placement.

Aggregates used in concrete mixtures should have adequate strength and should be weather resistant. These materials should be free of foreign or deleterious (potentially harmful) matter, since this may reduce the quality of the concrete.

Aggregates should be well graded (uniform sizes of particles) for efficient usage of the cement paste and to assure total coating of aggregate particles with cement paste material. The quality of a concrete mixture also is dependent upon the voids between aggregate particles being filled with cement paste.

The quality of the cement paste also affects the quality of the concrete mixture. The water/cement ratio and extent of curing are important. The greater the amount of water used, the weaker the cement paste, and therefore the less resistant the concrete mixture is to weathering, chemicals, and deicing salts.

There are five types of portland cement manufactured to meet specific needs and requirements. Type I is a general purpose cement. Type II is slow curing with low heats of hydration and typically is used in building structures of considerable mass, such as large piers, abutments, or retaining walls where sulfate concentrations in ground water are abnormally high. Additives such as fly ash have been added on occasion to hold down high heats of hydration.

Type III cement often is used in concrete patches where high early strength is critical. Type IV is slow curing with low heats of hydration and is used most often in the construction of dams and other massive structures where heats of hydration are critical. Additives such as fly ash have been added on occasion to hold down high heats of hydration.

Although not used to a large extent in this part of the country, Type V cement most commonly is used in the western section of the United States. It is used in concrete exposed to severe sulfate action.

Water used for drinking generally is suitable for making concrete. If there is doubt concerning the quality of water, laboratory analyses to determine chemical makeup and appropriateness for use in concrete mixtures should be conducted.

Air entrainment mixtures are added to improve workability, increase resistance to freezing and thawing, improve resistance to deicing chemicals, increase resistance to sulfates, and improve the watertightness of the concrete mixture.

Retarding mixtures are used to delay the hardening or setting time of concrete to permit finishing during times when hardening is accelerated, as in hot weather or when finishing is difficult because of specific construction features.

Water-reducing admixtures are used to reduce the amount of mixing water required. An increase in strength most often is associated with the use of water-reducing admixtures when cement content and slump remain constant. Problems with drying shrinkage often may result, however.

Set-accelerating mixtures are used to hasten setting and strength gain in concrete mixtures. Calcium chloride may be used to accelerate setting and strength gain, although the chlorides do have a detrimental effect on reinforcing steel. Type III cement also may be used for high early strengths. There are also proprietary brands of quick setting cements (SET-40, DURACAL, TIGERCRETE). High heats of hydration are a problem with the use of set-accelerating mixtures.

### **2.2.2 Handling of Concrete Materials**

Cement, free of lumps, should be stored in a dry place in a manner to prevent contamination by other materials.

Fine and coarse aggregates should be stored separately. Aggregates must be clean and the moisture content of stockpiled aggregates accounted for in the design of the concrete mixture.

Designs for concrete mixtures vary dependent upon the intended use of the concrete. Mix design involves determination of the appropriate proportions of coarse aggregate, fine aggregate, cement, water, and admixtures to produce a concrete with the desired properties. The design of concrete mixtures is an engineering consideration.

The quality of a concrete mixture may be determined by the following:

- a. evaluation (testing) of all materials used,
- b. field slump testing to determine the amount of water used in the mixture,
- c. testing to determine the percentage of air voids in the mixture, and
- d. testing to determine the compressive strength of concrete cylinders molded from material in the field to determine if the material reached the design strength.

Evaluation of the quality of concrete should be conducted by trained technicians using appropriate equipment. Compressive-strength evaluations should be conducted by a qualified laboratory.

### **2.2.3 Placement of Concrete**

There are several critical concerns to be aware of when placing concrete. Forms should be clean, of the proper dimensions, and properly braced or anchored. Reinforcing steel should be positioned according to the design. Also, reinforcing steel should be clean and free of dust, dirt, oil, or mill scale. The minimum cover for reinforcing steel varies from 1-1/2 to 3 inches, dependent upon specific design considerations.

Mixing equipment should be in proper operating condition. The drum for the transit mixer must rotate at least 70 revolutions per minute. If an on-site mixer is used, the equipment must be inspected for deficiencies contributing to improper blending of the concrete. Concrete may be transported on site by chutes or by transport buggies. Concrete should be consolidated using vibrators that penetrate no more

than 2 inches into a previously placed layer. Thickness of concrete layers should be no more than 12 inches per lift. Vibrators should be operated for no more than 10 seconds in any single location.

#### **2.2.4 Finishing Concrete**

Finishing is required for exposed concrete surfaces as well as for concrete surfaces in contact with forms. Finishing exposed concrete surfaces involves striking off or screeding to remove excess materials, floating and filling in any open textured areas, and smoothing to the desired finish (tining or texturing).

Concrete surfaces in contact with forms must be finished after forms have been removed. An ordinary surface finish, which involves filling all cavities on the surface with mortar, should be used whenever possible. This procedure is sometimes called pointing. A rubbed finish involves rubbing the surface with a carborundum stone, water, and mortar. Rubbing is continued until a smooth finish is obtained. A rubbed finish often is used in combination with an ordinary surface finish.

#### **2.2.5 Curing of Concrete**

Curing is an important (and perhaps most overlooked) aspect of placing concrete. Curing basically involves adding or controlling moisture during the critical periods of concrete strength gain (usually between 7 and 28 days) (Figure 31). Curing methods that have been used with some success include:

1. ponding water on the concrete surface,
2. continuous spraying or sprinkling of water on the concrete surface,
3. using wetted coverings (wet burlap), and
4. application of a waterproof membrane (curing compounds or plastic or wax-paper sheets).

Cold weather curing may require special treatment such as injecting steam or using blanket insulation to maintain normal temperatures.

#### **2.2.6 Problems In Concrete**

Typical problems observed in concrete construction are surface deterioration (scaling and popouts), spalling, and cracking.

Causes of surface deterioration -- scaling and popouts -- include the environmental factors of friction or abrasion, exposure to chemicals, and freezing and thawing. High water/cement ratio, low air content, and poor quality or contaminated aggregates also result in scaling and popouts. Another cause is improper construction procedures such as poor or improper finishing and segregated materials resulting from improper consolidation or vibration.

Spalling may result from internal pressures caused by corrosion of reinforcing steel (Figure 32). Factors contributing to corrosion of reinforcing steel include moisture penetration, contamination by deicing chemicals, accumulation of debris, and insufficient cover for reinforcement steel. Spalling also may result from external edge pressures. Critical external edge pressures are located at bearing areas, joints, and cracks resulting from differential settlement.

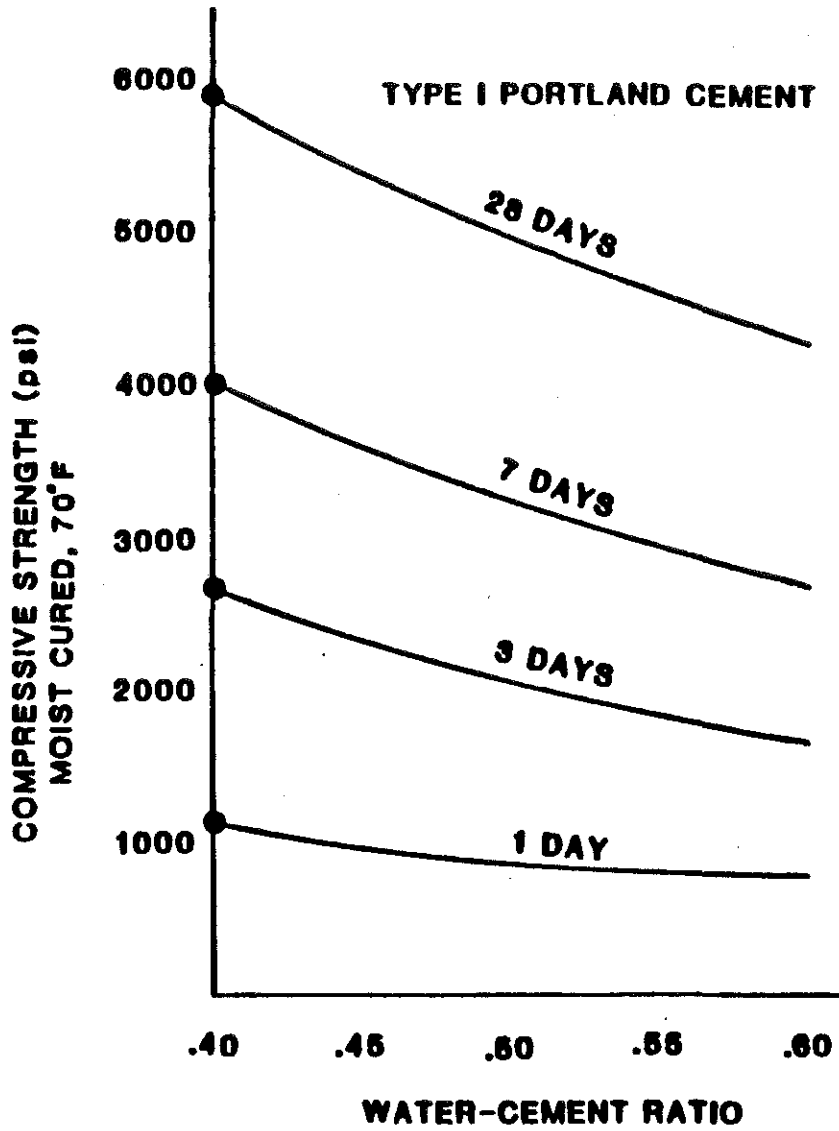

Figure 31. Typical Age-Strength Plot.

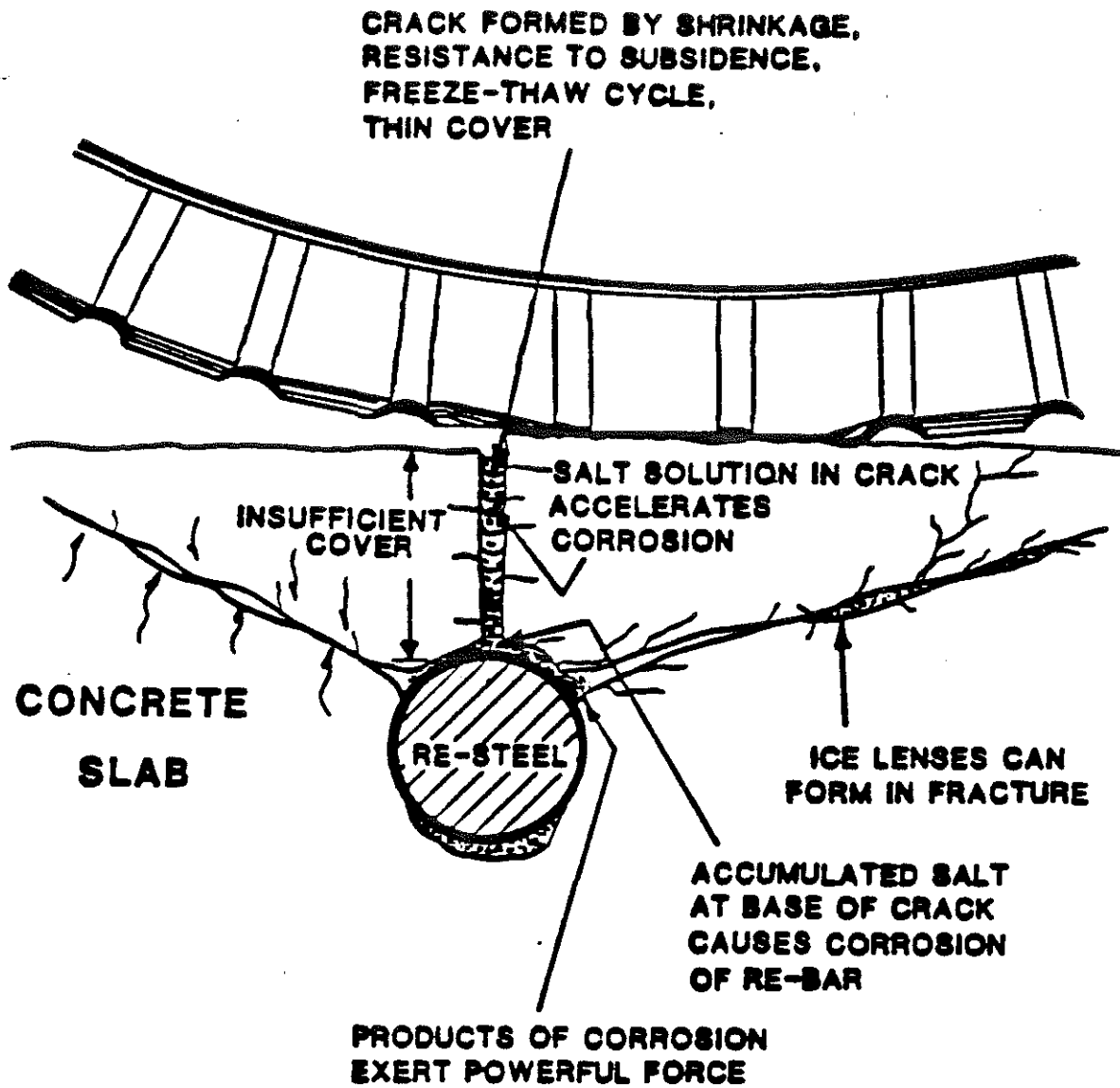

Figure 32. Evolution of a Spall.

A third problem concerning concrete construction is cracking. Surface cracking most often results from shrinkage of the concrete, minor flexural problems, and cracking resulting from reinforcing steel. On the other hand, deep cracking most often results from irregular or differential settlement, embankment pressures, horizontal pressures, seismic damage, and overloads.

### **2.2.7 Repair of Concrete**

Repair of concrete involves removal of deteriorated concrete, design and placement of framework and support for repair of structural concrete members, bonding between old and new concrete, patching, surface refinishing, repair of cracks and fractures, use of coatings and seals, and cathodic protection for reinforcing steel.

Removal of deteriorated concrete involves estimating quantities for removal and removing all deteriorated materials. A clean sound surface is required for all repair operations. Also, caution should be used in the selection of hammers for removal of concrete: 30 pounds above reinforcing steel and 15 pounds below reinforcing steel. Sawing is recommended whenever possible. Also, loose bars should be tied at intersections. Blast cleaning should be used to clean surfaces of exposed concrete and exposed reinforcing steel.

Each repair area should be analyzed to determine if formwork and/or support is needed. Forms and supports should be designed to meet each specific situation.

A bonding agent (anything from cement paste to epoxy) should be used on the surface of the old concrete prior to placement of the new concrete.

Patching materials should be designed to minimize shrinkage. This usually is accomplished by reducing the water/cement ratio. The use of a latex additive also may reduce the amount of water required for workability and reduce the permeability of the patch. Proper curing is essential for patches.

Pneumatically applied mortar (shotcrete or gunnite) may be used to restore the surface to concrete. These materials are conveyed through a hose and nozzle and projected at high velocity onto a concrete surface. The mix consists of cement, fine aggregate, and water and usually involves a high cement content and low water/cement ratio. Curing is very important. Seven days of water curing is advisable. Use of the natural finish also is advised. Latex modified concrete or mortar may be used as an alternate patching material.

Repair strategies for cracks are dependent upon specific causes for the cracking. For instance, cracks resulting from settlement, flexure, or diagonal tension will reoccur unless repairs to correct causes are completed.

Cracks scheduled for repair should be cleaned thoroughly prior to patching. Large non-moving cracks may be repaired by "veeing" out the surface of the crack and filling with epoxy mortar. Small cracks (0.003 to 0.25 inch) can be welded together through the use of injection equipment and specially formulated epoxies (Figure 33).

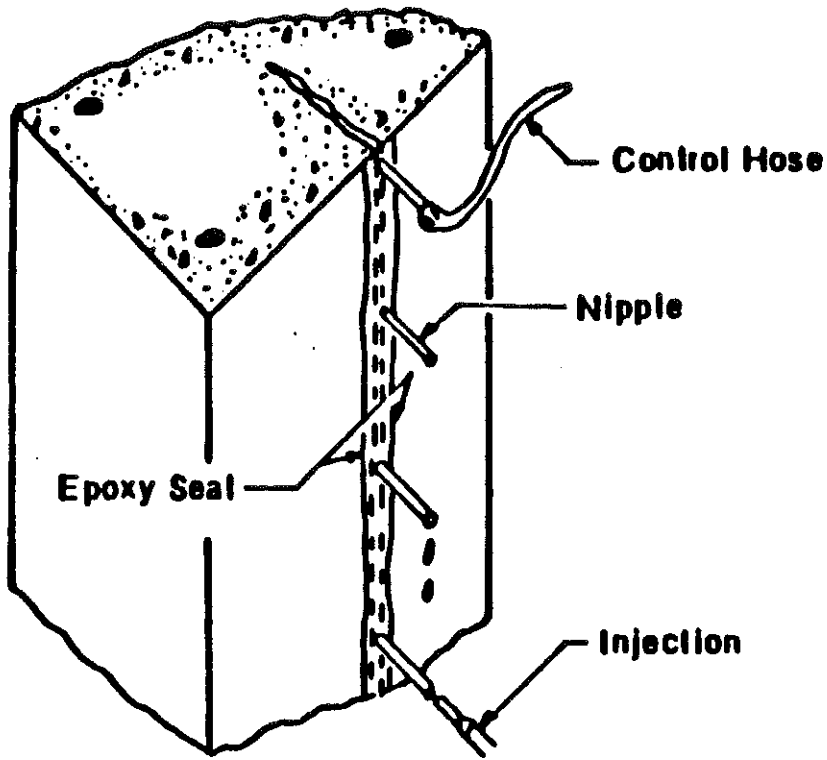

Figure 33. Repairing Cracks by Epoxy Injection.



Map cracking, which may be too small for individual repairs, may be repaired by thin bonded overlays of latex or epoxy modified concrete or thin bituminous membranes. This repair most often is accompanied by first removing the deteriorated concrete down to sound concrete.

Sealants and coatings may be used to waterproof and protect a concrete surface. Protective materials include oil and rubber resins, petroleum derivatives, silicones, and other materials. A solution of 50 percent boiled linseed oil and 50 percent mineral spirits is one of the most widely used protective coatings. Epoxies also are widely used.

The only remedial procedure short of removal and replacement of the concrete is cathodic protection, which has proven effective at reducing corrosion of reinforcing steel. Cathodic protection has received only limited usage and may still be considered experimental in some areas. Use of epoxy coated reinforcing steel for new or rehabilitation construction also is effective for prevention of corrosion of reinforcing steel.

## **2.3 STEEL REINFORCED CONCRETE**

### **2.3.1 General**

Portland cement concrete may be reinforced by either of two methods. One method embeds steel reinforcement in the concrete to provide additional tensile strength. The tensile strength of nonreinforced concrete is approximately 10 percent of the compressive strength of non-reinforced portland cement concrete. The second method puts high strength steel tendons under tension in prestressed concrete. The tension forces are then transferred to the concrete member, placing the concrete in compression, which is the strength mode in which concrete is strongest (Figure 34).

There are three methods of prestressing: pretensioning, posttensioning, and combination methods. Pretensioning requires prestressing the tendons before the concrete is placed. After the concrete has developed the specified or design strength, anchorages at the ends of the forms are released, thus placing the concrete in compression. The post-tensioning method requires that prestressing tendons be installed in ducts within the concrete. The prestressing tendons are then stressed and anchored after the concrete has developed a specified strength. In combination methods, part of the prestressing tendons are pretensioned and the remainder are post-tensioned.

### **2.3.2 Protection of Reinforcing Steel**

One of the greatest problems with reinforced concrete is that of corrosion of the embedded reinforcement. As reinforcing steel corrodes, it expands, causing the concrete to crack and spall. Concrete generally has excellent protective qualities. Therefore, one of the most effective methods of protection for reinforcing steel is to provide sufficient cover of concrete to prevent the infiltration of salts, chemical deicing agents, and/or moisture through the concrete to the reinforcing steel. Typical minimum concrete cover for reinforcing steel for various conditions include the following:

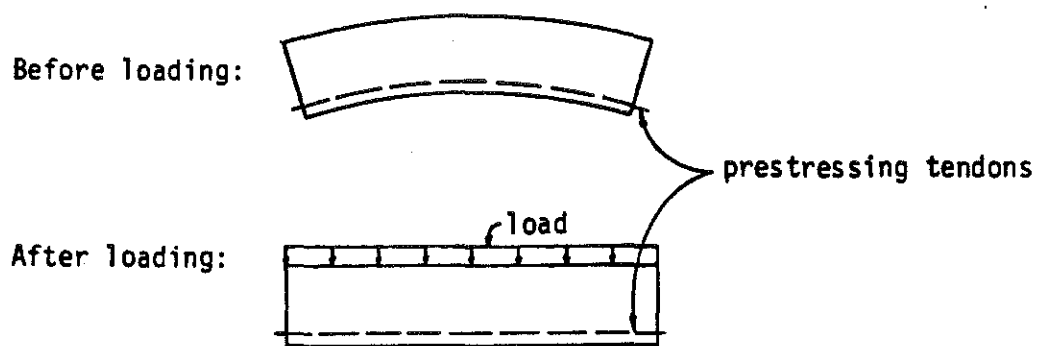

Figure 34. Sketch of a Prestressed Beam.

1. Concrete cast against and permanently exposed to earth -- 3 inches;
2. Concrete exposed to earth or weather:
  - a. principal reinforcement -- 2 inches and
  - b. stirrups, ties, and spirals -- 1 1/2 inches;
3. Concrete bridge slabs:
  - a. top reinforcement -- 2 inches and
  - b. bottom reinforcement -- 1 inch;
4. Concrete not exposed to weather or in contact with the ground:
  - a. principal reinforcement -- 1 1/2 inches and
  - b. stirrups, ties, and spirals -- 1 inch; and
5. Cover for the above conditions should be increased for severe exposure conditions.

Protection of prestressing steel is critical. As indicated above, concrete can be an excellent protector of prestressing steel provided the concrete is of high quality.

The properties of concrete that provide a high degree of protection include high alkalinity, low permeability, resistance to the flow of electricity, and relative freedom from cracks.

There are hazardous conditions that can lead to deterioration of the prestressing tendons. The presence of salts, for example, can lead to corrosion. The presence of chemically aggressive agents such as calcium chloride, hydrogen sulfide, carbon dioxide, and nitrates can lead to direct chemical attack. Other conditions such as a wet environment, voids and bond failures between concrete and prestressing steel, insufficient concrete covering the prestressing steel, and cracks (as small as 0.004 inches) that permit the penetration of moisture to the steel contribute to the deterioration of the steel.

### ***2.3.3 Protective Coating for Reinforcing Steel***

Protective coatings also may be used to protect reinforcing steel. One of the most widely used protective coatings is epoxy. The use of epoxy-coated reinforcing steel may reduce the amount of concrete cover required. More often, the use of coated steel simply provides additional protection against corrosion.

### ***2.3.4 Deterioration of Steel Reinforced Concrete***

There are many factors that can cause deterioration in concrete. Poor design details such as deck drains not being provided, or improperly provided, and/or improperly maintained will not allow drainage of bridge decks and other concrete structures and will therefore create high moisture conditions that may lead to deterioration of concrete.

Spalling often can result from insufficient room for expansion between concrete slabs at joints. Insufficient concrete cover for reinforcement steel can result in corrosion of the reinforcing steel and eventually lead to spalling of the concrete (Figure 32).

Construction deficiencies, such as a lack of sufficient support for the concrete, can lead to premature deterioration of concrete structures. Examples of insufficient support include soft spots in the subgrade for concrete pavement and approach slabs for bridges and culverts or improper contact between bridge deck concrete and bearing points.

Early removal of formwork also can contribute to premature deterioration of concrete.

Improper or insufficient vibration during construction may result in surface cracking as the mix settles around reinforcing steel. On the other hand, excessive vibration can cause segregation of the concrete mixture.

Improper construction and/or placement procedures can result in voids under the reinforcing steel. Also, clay, shale, or other deleterious materials in a concrete mixture can result in reduced quality.

Extreme temperature variations can contribute to premature failures or deterioration of concrete mixtures. For example, concrete expands or contracts at 6.0 millionth of an inch per degree fahrenheit temperature rise or fall. If concrete is prevented from expanding or contracting, cracking or spalling can occur.

Porous concrete absorbs water. Since water expands when it freezes, it creates high internal pressures within the concrete and this can produce cracking and/or spalling if these pressures exceed the strength of the concrete.

Aggregates may expand or contract at different rates than the cement paste used to form the concrete matrix. Aggregates with lower rates of expansion may cause high tensile stresses, which can cause cracks or spalls.

Chemical deterioration of concrete produce distinctive symptoms such as surface deterioration in the form of scaling and spalling, random cracking in unrestrained members, swelling and parallel cracks in compression members, and protruding aggregate.

Elements contributing to chemical deterioration include salts of chemical deicing agents (salts increase water retention and also contribute to weathering through recrystallization) and chemicals found in soil and/or water. (Ammonium and magnesium ions react with the calcium in the cement paste. Sodium, magnesium, and calcium sulfates react with tricalcium aluminate in the cement paste. Acids chemically transform the composition of the cement paste.)

Deterioration of concrete also can occur when reactive aggregates and high alkali cements cause development of tensile forces within the concrete mass. Symptoms for this condition are swelling, map cracking, and popouts.

Moisture absorption in concrete may cause swelling. Soft water can leach out the lime in the cement paste, leaving a powdery residue. Other factors contributing to concrete deterioration are wear or abrasion of concrete, which may cause scaling, raveling and cracking at joints, and scarring of concrete surfaces. Shrinkage and flexural forces set up tensile stresses resulting in cracking. Setting shrinkage can cause shallow surface cracking. Drying shrinkage takes place over a longer period but also results in surface cracking as the concrete shrinks and tensile forces develop.

Collision damage is a significant factor relative to deterioration or damage of concrete in bridges and culverts. Bridge piers and abutments may be struck by automobiles, trucks, ships, and barges. Overhead beams and girders also may be damaged.

Concrete surfaces may be damaged by scouring by sand, silt, ice floes, and other floating debris. Concrete piles may be damaged by shock waves while being driven. The speeds of shock waves passing through the concrete (aggregate, cement paste, and reinforcing steel) is not constant and actually may be additive. Shock waves may lead to cracking and spalling of the concrete mass.

Symptoms of overstressing of a concrete deck are longitudinal cracking over a longitudinal supporting element and lateral cracking over a lateral supporting element. Symptoms of overstressing of concrete beams and girders are diagonal cracking at the end of a simple beam and vertical cracking running up from the bottom at the center of a simple beam, and vertical cracking from the top of the beam extending downward for a beam that is continuous over a bearing area.

Deterioration can result from temperatures in excess of 300 F, as this can cause weakening in the cement paste and lead to cracking and spalling. Conditions of extreme heat often result in fires associated with accidents or curing during cold weather construction.

Generally, any kind of foundation movement that results in sizeable tensile strains will result in cracking. Vertical cracking is predominant where foundation movement is involved.

Corrosion of reinforcing steel and prestressing wire in the concrete mass causes tremendous pressures resulting from expansion associated with the corrosion products that cause the concrete to crack and spall. The volume of corroded steel is approximately seven times the volume of uncorroded steel. Corrosion of the prestressing wire combined with the high tensile stresses can result in failure of the prestressing wire. Failure of a sufficient number of prestressing wires will cause the member to lose its tensile strength, and this can lead to failure under heavy loading conditions.

The strain (elongation) produced by the allowable stress (force per unit area) in reinforcing steel is approximately six times the ultimate tensile strain of concrete resulting in the eventual elongation of the tensioning steel. This condition typically results in narrow lateral cracks in concrete beams where tensile stresses are highest.

Deterioration of prestressed concrete members can occur because of a loss of prestress or because of cracking. Loss of prestress can occur because of creep of the prestressing steel, shrinkage of the concrete, creep of the concrete, elastic deformation of the member, loss of anchorage for the post-tensioning, and loss of friction for posttensioning steel.

Cracking is most likely to occur in the vicinity of anchorages for post-tensioning steel, at mid-span along the tensile face of the member (narrow lateral cracks), and at mid-span along the compressive face (longitudinal splitting).

## **2.4 ASPHALT**

Bituminous materials are used routinely as a wearing surface material and/or as a waterproofing sealant. Use of bituminous materials as waterproofing membranes has diminished somewhat with the development of other protective systems. Recently developed protective systems, such as coated reinforced steel, have provided alternate systems for bridge engineers. Bituminous membranes perhaps are more widely used for rehabilitation than for new construction. The effectiveness of bituminous membranes and reports of the successes of the various field installations vary considerably.

Early membranes consisted of built up layers of bituminous material and reinforcement such as fiberglass cloth. Later, epoxy resin systems were used in combination with bituminous wearing courses. More recent developments have included the use of preformed membranes, which are unrolled and lapped on the deck surface. Systems may be either hot- or cold-applied. Also, preformed systems are reported to offer better stress-relief and crack-bridging characteristics.

Placement of membranes typically are accompanied by a 1-1/2- to 2- inch thick bituminous concrete wearing course to provide durability under traffic. Evaluations should be conducted to ensure the structure has sufficient strength to carry the additional deadload. Slippage between the deck, the membrane, and the wearing surface also is a critical concern. Slippage may limit the application of membranes and bituminous wearing surfaces to grades of four percent or less. A disadvantage of membranes and bituminous wearing surfaces is the concealment of future deterioration of the bridge deck.

Bituminous mixtures used as wearing surfaces over waterproofing membranes should be dense enough to prevent infiltration of moisture and salts down into the underlying concrete of the structure. Specific mixture designs will vary dependent upon aggregate sources and asphalt materials. Aggregate sources should have high durability characteristics to withstand the abrasion and wear associated with traffic. Bituminous materials also are used for patching potholes in bridge decks during emergency situations. Bituminous materials generally are not considered permanent patches for bridge decks.

## **2.5 TIMBER**

Timber is a renewable building material available throughout the United States. Timber has a high strength-to-weight ratio and when properly protected is very durable. Pine and oak are the most commonly used woods for construction in Kentucky.

### **2.5.1 Physical Properties**

Wood is different from other structural materials in that it is organic in nature. Wood has a microscopic cellular structure. The cells or fibers vary in size and influence both the physical and mechanical properties of wood. Properties of wood vary with temperature. Expansion and contraction characteristics of wood vary perpendicular to the grain with the specific gravity. The coefficient of thermal expansion for wood is in the range of 25 to 45 millionths of an inch per inch per degree of Fahrenheit. The

coefficient of thermal expansion parallel to the grain is independent of specific gravity and varies from approximately 1.7 to 2.5 millionths of an inch per inch per degree of Fahrenheit.

### **2.5.2 Strength**

Timber is much stronger parallel to the grain than across the grain. Timber is strong in both tension and compression, but is most often used in compression because of connection problems associated with the use of timber in tension. Timber may be used as beams where both compressive and tensile capabilities are utilized. The strength of timbers is most influenced by straightness of grain and moisture. The strength of timbers vary over a considerable range and is closely related to the specific gravity of the wood. The compressive strength parallel to the grain is much greater than across the grain. The tensile strength parallel to the grain is several times as great as compressive strength. The tensile strength is affected less by moisture and also is weaker across the grain. Shearing strength also is an important consideration in the design of timber beams. The strength of a timber in bending is a realistic measure of timber capabilities (Figure 35).

Uncured or "green" timber is more resilient and flexible than cured wood. However, proper curing provides benefits of decreased shrinkage, improved strength, reduced weight, improved resistance to decay, and improved workability; and curing is a necessary preparation for treatment with preservatives. There are no particular advantages for air drying or "seasoning" versus kiln drying. Shrinkage during drying varies from 2 to 5-1/2 percent across the grain to very little along the grain.

Toughness is the ability to resist shock or blows. Toughness involves both strength and flexibility. Green timber is tougher because of its greater flexibility. Hardness is important when timber is used for decking. Seasoning greatly increases the hardness of all woods.

### **2.5.3 Durability**

There are timber members that have been in service on bridges for over 100 years. Wood is not subject to significant chemical change with time when adequately protected. Wood is subject to slight discoloration from long exposure to air. The durability of wood is somewhat related to the character, size, and location of defects (knots, decay areas, etc.). Defects are used to determine or establish structural grades of timber. The durability of timber also is related to temperature. Dry wood expands slightly when heated. Conversely, wet wood shrinks because of evaporation of moisture. Timber tends to lose some of its strength when raised above room temperature. There may be some permanent loss of strength when the wood returns to the original temperature, dependent upon the type of wood, moisture content, elevated temperature, and length of exposure. Dry wood is less influenced by temperature than wet wood because the evaporation caused by an increase in temperature is more influential than the effect of the temperature increase.

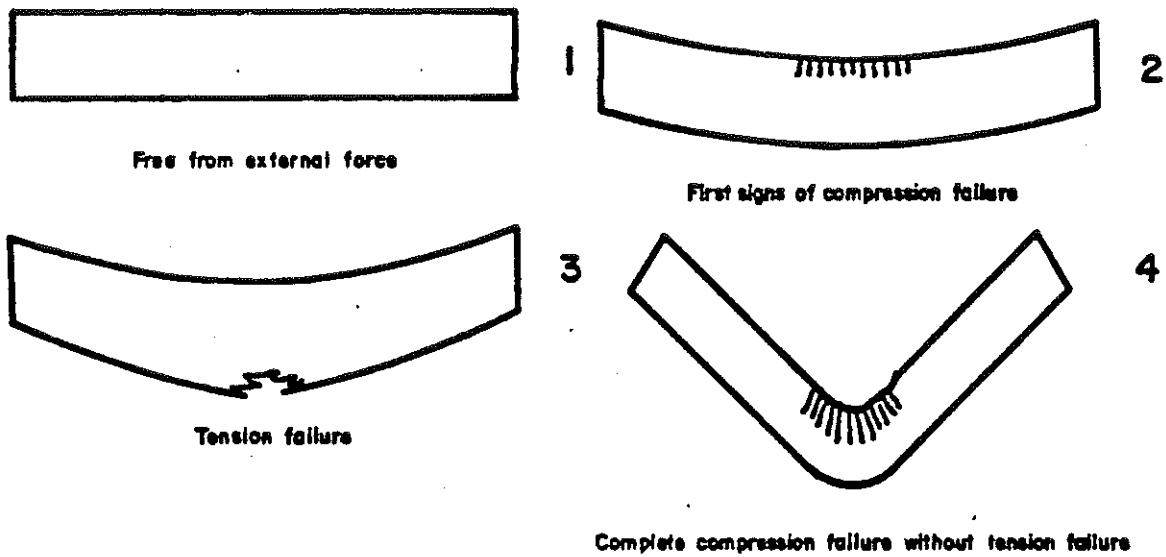

- (1) well seasoned uniform wood: 1, 2, 3
- (2) very dry wood: 1, 3
- (3) green wood: 1, 2, 4

Figure 35. Typical Failure Mechanisms for Timber.



The most effective method of protection for timber used in bridge construction is creosote pressure treatment. The treatment is performed by placing cured timber in sealed steel containers capable of withstanding pressures up to 200 pounds per square inch and then applying the creosote. Other treatments that have been used are pentachlorophenol in a heavy oil solvent (penta-oil treatment) and inorganic salt solutions applied using pressure methods. The salt treatment provides less water repellency than the creosote and pentaoil, which makes timber treated with inorganic salt more susceptible to weathering. Research is continuing to determine the effect of wood preservatives on the environments. It is advisable to check with environmental and natural resource officials to determine the legality associated with the use of any preservative.

Timber also is subject to damage by insects such as termites and carpenter ants. Insecticides should be applied periodically to minimize potential damage. Timber preservatives and treatments for insect control are sometimes potentially damaging to the environment. The specifics relating to the use of any preservative or treatment for insect control and the relative impact on the environment should be understood before the timber is used.

#### ***2.5.4 Advantages and Disadvantages***

The advantages of using timber for bridge construction and rehabilitation projects are its relatively low cost, a high strength-to-weight ratio, high durability when properly treated, ease of construction, ease of fabrication using conventional and readily available equipment and tools, ability to withstand large momentary overloads, and ready availability.

The disadvantages of using timber for bridge construction and bridge rehabilitation projects include inability to support very heavy loads, susceptibility to vermin (termites, etc.), susceptibility to fungi (decay), susceptibility to weathering and warping, susceptibility to chemicals, susceptibility to fire, and susceptibility to mechanical wear.

#### ***2.5.5 Timber In Rehabilitation of Bridges***

Timber often is used in rehabilitation activities for small bridges, especially for those situations where work crews have limited skills. The availability of materials or problems associated with the delivery of other materials also may enhance the potential for applications of timber.

Certain precautions are necessary when using timber for rehabilitation of bridges. Areas where debris can accumulate on the surface of timber should be avoided because the debris can accumulate moisture, a principle factor associated with deterioration of timber. Timber ends and connector areas are especially susceptible to decay because cutting provides natural openings in the grain. Timbers placed on the ground or at waterline are especially trouble prone because of moisture problems.

Timber also is susceptible to mechanical abrasion. This is especially critical when using timber as a decking material. Timber decking may be protected by plating in the wheel paths or by a bituminous

surface treatment. A bituminous surface seal not only protects the decking from wear but also contributes to the watertightness of the timber.

Decay and/or vermin damage also is a factor in the use of timber in bridge rehabilitation. Advanced decay can be detected by sounding with a hammer. Cores can be taken in suspect areas to determine the extent of decay or deterioration. The effectiveness of coring is limited because it is first necessary to select the area for coring, and this is a somewhat subjective decision. More sophisticated techniques are available but generally require considerable experience and expertise for proper application. The "Shigometer" operates upon the principle that a resistance to a pulsed current decreases as concentrations of cations increase in wood. Cation concentrations increase in wood undergoing fungal staining and decay. Chemical decay indicators also can be applied to a core sample to detect early decay.

If the residual strength of a timber member is inadequate, replacement or reinforcement is necessary. Rehabilitation by replacement of a member (either partial or total) requires a structural evaluation to ensure proper support during the repair activity. An evaluation should be conducted to determine the specific cause of the decay or deterioration because the replacement or reinforcement members will be exposed to the same conditions as the existing member. Replacement of a portion of a member may be appropriate in those situations where only a portion of the member is defective and partial replacement presents no structural problems. Decayed members should be replaced to guard against further spread of decay. When this is not practical, sister members may be added to reinforce weakened members. Additional preservative treatment should be applied to slow the rate of decay.

Very little has been done to extend the service life of existing timber members used in bridge rehabilitation. Two fumigants, sodium methylthiocarbamate (vapam) and trichloronitromethane (chloropicrin), have been used successfully to arrest decay in Douglas fir. These fumigants may be effective up to 6 years. Specific information pertaining to the application of fumigants and local laws on pesticides should be obtained before any treatment is applied.

## **2.6 SOILS**

### **2.6.1 Soil Classification**

Soils may be classified on the basis of particle-size distribution and the properties of the fine-grained portion of the soil. One soil classification system is the Unified Soil Classification System. Major categories of the Unified Soil Classification System are a) coarsegrained, b) fine-grained, and c) highly organic soils. Further subdivisions of coarse-grained soils may be determined on the basis of a) particle sizes within a specific category and b) gradation characteristics within a specific category. For fine-grained soils, subdivisions are based on the consistency of the fine matrix (measured by Atterberg limits, etc.).

Coarse grained soils have a single-grained structure. There is little or no attraction between the particles. Thus, gravity is the principle force holding the particles together. Coarse-grained soils typically have large voids or spaces between particles.

Fine-grained soils tend to form chains of particles resembling a honeycombed structure or sheets. This is particularly true for fine silts and clays. There is a considerably greater attraction between fine silt and clay particles than for coarse-grained particles such as gravel. The sizes of spaces between particles are greater than the particle size. Very fine soils tend to form a sheet structure where voids are much greater than the particle size. In reality, most soils do not consist of uniform or equal-sized particles.

Highly organic soils typically consist of all or a majority of the materials involving decayed or decaying organic material. Peat is an example of a highly organic material. Many top soils also are highly organic.

All soils contain water in the voids between the particles. Soil tends to hold water because of the attraction between water molecules and soil particles. This is especially true for fine-grained soils. Even air dried soils typically retain a thin film of water. Oven drying may be used to remove the thin film of water surrounding individual soil particles. A soil is said to be saturated (100 percent saturation) when all voids are filled with water.

### **2.6.2 Soil Strength**

The strength of soils is associated, in part, with the frictional resistance developed when one particle slides across another. Frictional resistance is the principal factor associated with the shear strength of a coarse-grained soil. Another factor affecting the shear strength of a soil (particularly fine-grained soils) is the cohesion or attraction of the soil particles for each other. Cohesion generally is associated with the mineralogy of the soil rather than the particle size.

Fine-grained soils show less frictional resistance than coarsegrained soils. Clay particles tend to be long and plate-shaped rather than angular or rounded as are most sands, silts, and gravels. Cohesive soils are known for their ability to withstand large strains without rupturing. The term plasticity is used to define the ability of a soil to withstand large strains without rupturing. Clay, for example, has a large degree of plasticity. Water content also influences the degree of plasticity and strength of a soil. Shear strength, on the other hand, is reduced as the moisture content of the soil increases. The liquid limit of a soil is a measure of when the moisture content of the soil has reached a point where there is no measurable shearing strength.

### **2.6.3 Foundation Problems**

The performance of any structure is directly related to performance of the foundation. The reaction of soils in the foundation when placed under a load(s) is the major factor affecting the performance of the foundation.

Settlement of a bridge pier or abutment may result because of increased loads on the structure, displacement of a portion of the foundation bed because of scour or erosion, lateral displacement of the foundation bed because of lack of restraint, consolidation of the underlying foundation material, and failure of an underlying soil layer.

Some settlement is inevitable whenever a bridge or culvert is constructed. Results of analysis of soil samples, field investigations, and engineering calculations can be used to determine the expected amount and rate of settlement.

Unequal or differential settlement may have a serious impact on the performance of a structure (Figure 36). An accurate picture of foundation conditions and a knowledge of how foundation soils perform under loading allows for a fairly accurate prediction of anticipated settlement.

Settlement of granular soils such as gravel, coarse sand, and medium sand usually occurs as soon as the load is applied. Subsequent settlement thereafter usually is small. Settlement for silts typically occurs over a longer period of time. Settlement of silty soils also may increase with time because of a drop in the water table. Clays, because of their tendency to be plastic, consolidate slowly and at a decreasing rate as time passes. This behavior is due to the slow squeezing out of water in the clay.

Undermining of bridge piers by the scouring action of flowing water is one of the most serious threats to bridge foundations (Figures 37 and 38). Sudden floods can be extremely destructive because of the great and uncontrollable forces associated with the rapid flow of water. Erosion of the streambed also can contribute to the undermining of a pier or abutment because of increased velocities of the water.

The ability of a soil to support a load is termed its bearing capacity. The bearing capacity of any soil depends upon the physical properties of the soil and on the manner in which the load is applied. Bearing capacity also is affected by the type, size, spacing, and depth of footings and piles. A sudden increase in the water content of a soil reduces the frictional resistance and the cohesion of the soil (Figure 39). This, in turn, reduces the bearing capacity and shearing strength of soils, thereby increasing the possibility of sliding.

The distribution of pressure varies between single piles and a group of piles. A group of piles distributes the pressure associated with the applied load over a larger area or "bulb" and, in effect, reduces settlement. Settlement normally decreases as the foundation depth is decreased. Skin friction is the adhesive or shear strength developed between the pile and the soil. Dense granular soils make good foundation materials but piles driven through loose or soft deposits (loose sand or soft clay) have to be driven deep to establish an adequate bearing capacity.

## **2.7 IRONS AND STEELS**

Iron has been used in bridges for at least 400 years. Most early forms of iron were not useful since they could not be loaded in tension and cheaper materials could be used in compression.

In the early 1700's, metal workers found they could mix a little slag into the molten cast iron and produce wrought iron. That material could be used to carry tension loads. Thereafter, wrought iron was used in the first bridges that were predominantly made from that metal. It was used until after the turn of this century and there are still in use some old small truss bridges made from this metal.

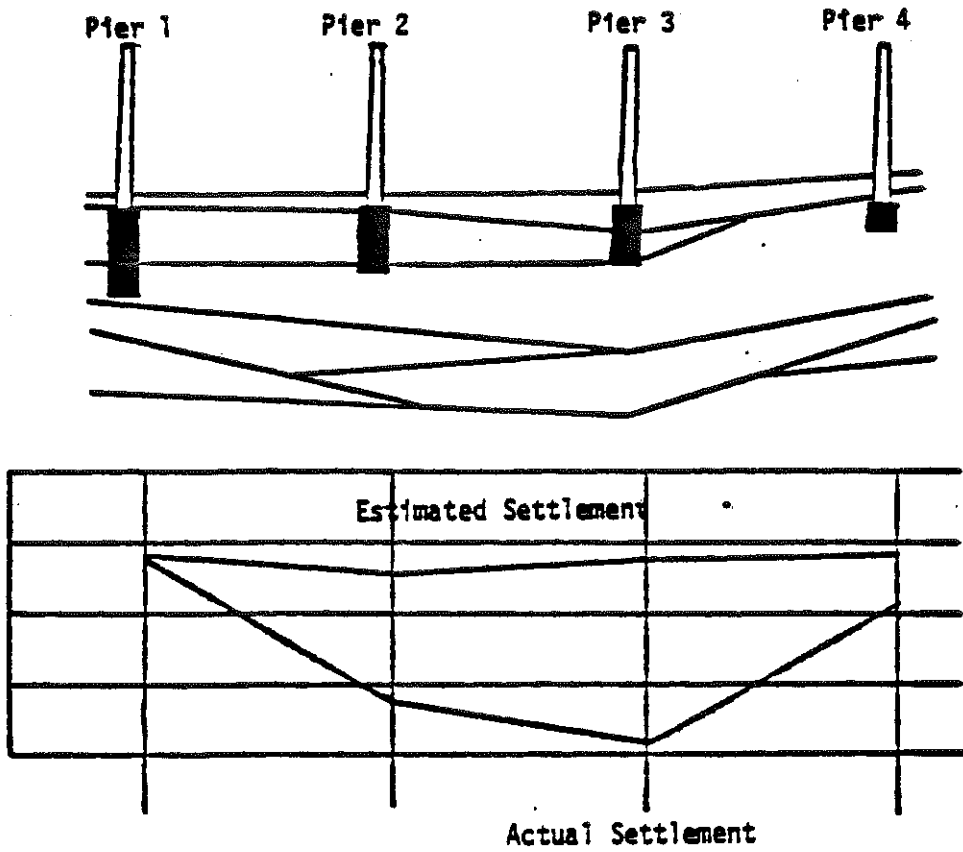

Figure 36. Illustration of Differential Settlement.

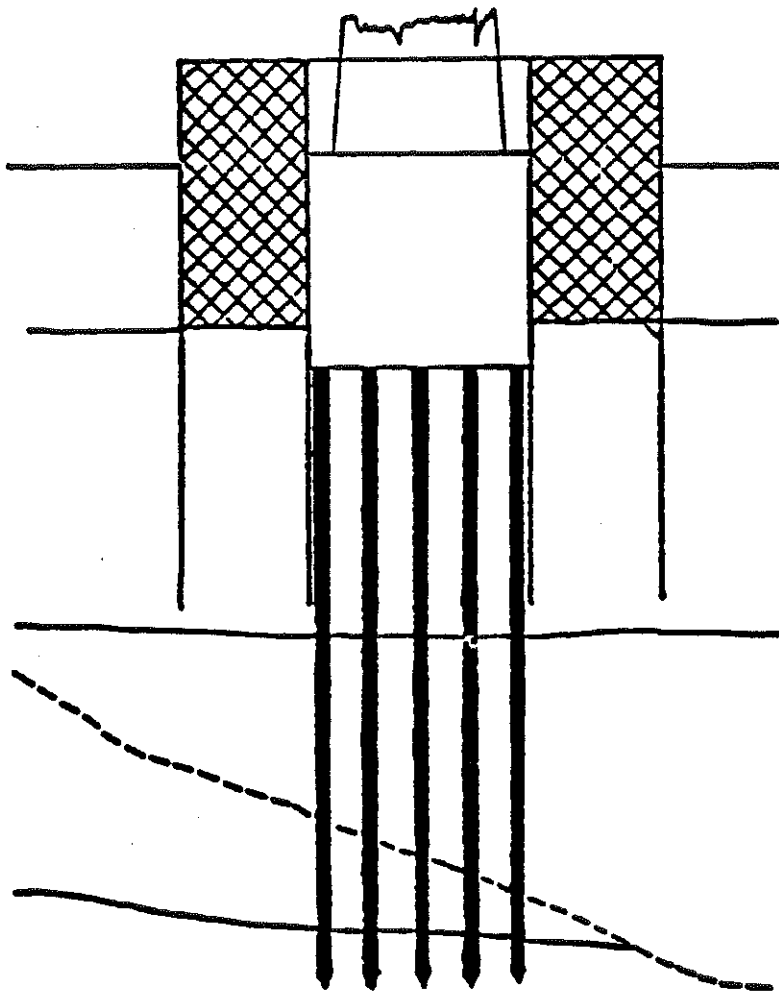
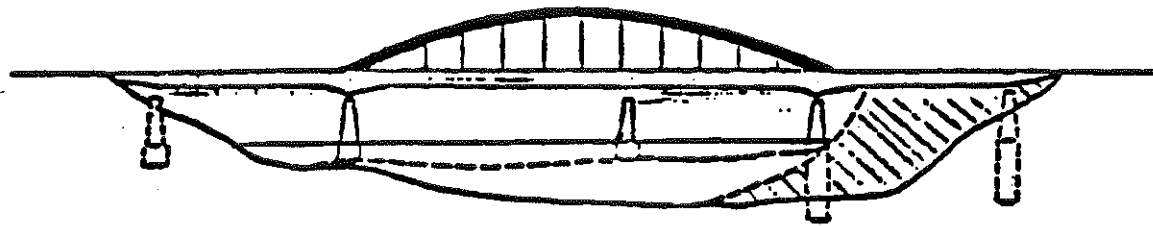

Figure 37. Illustration of Scour Foundation Failure.

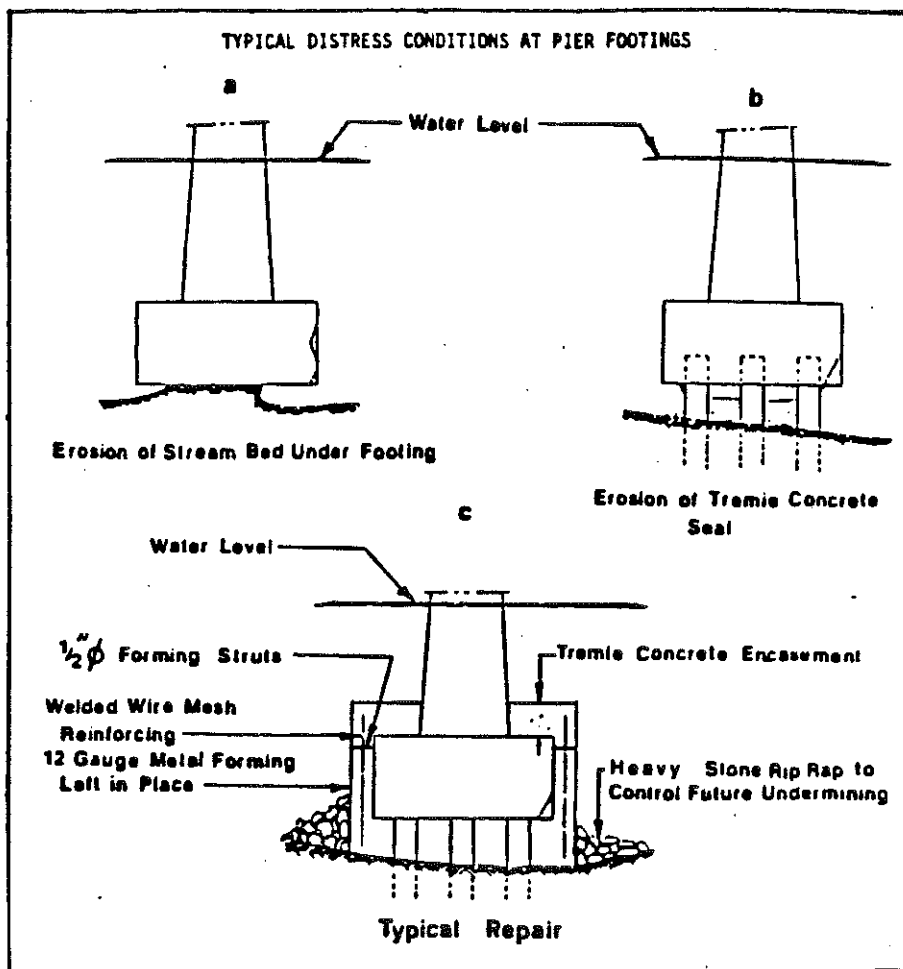
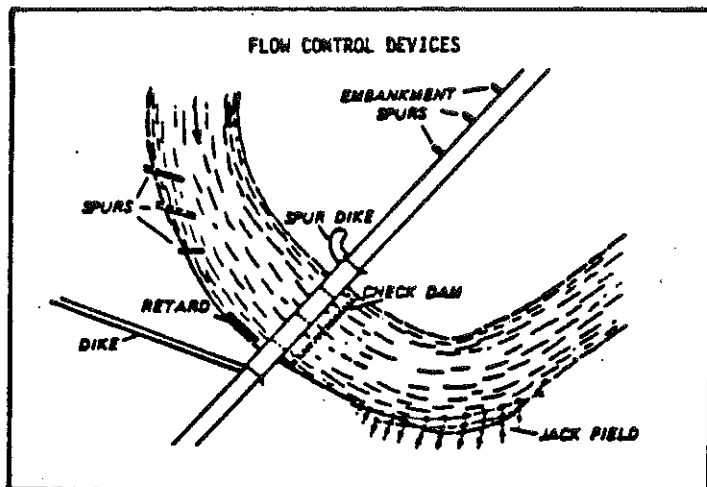

Figure 38. Illustration of Foundation Repair Procedures for Scour-Related Damage.

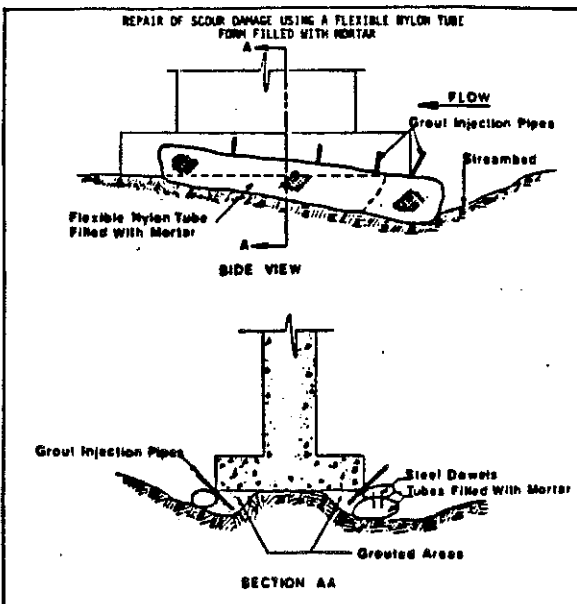
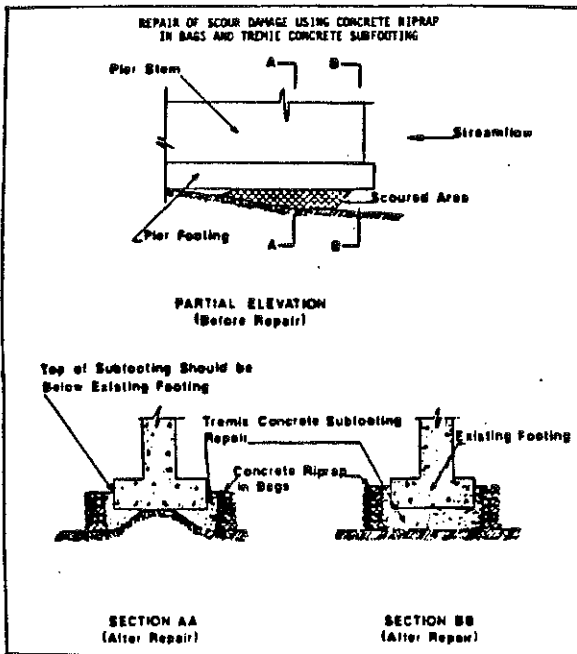
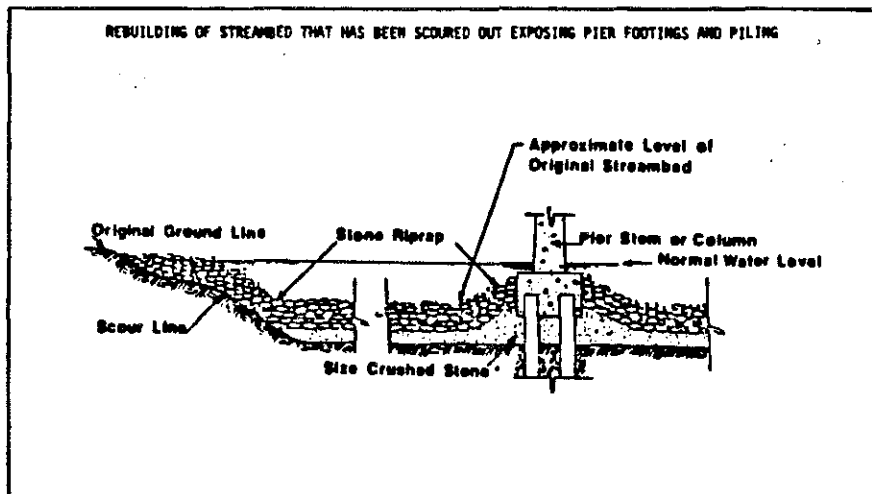
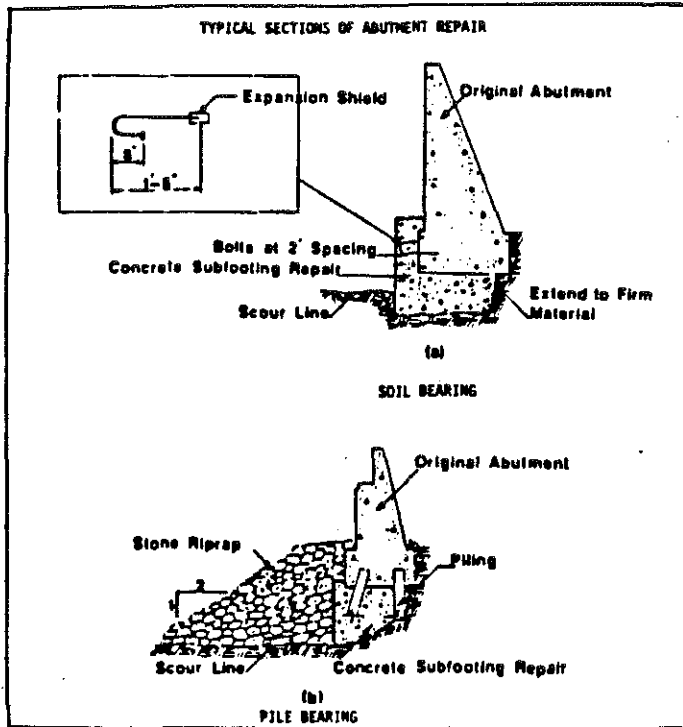
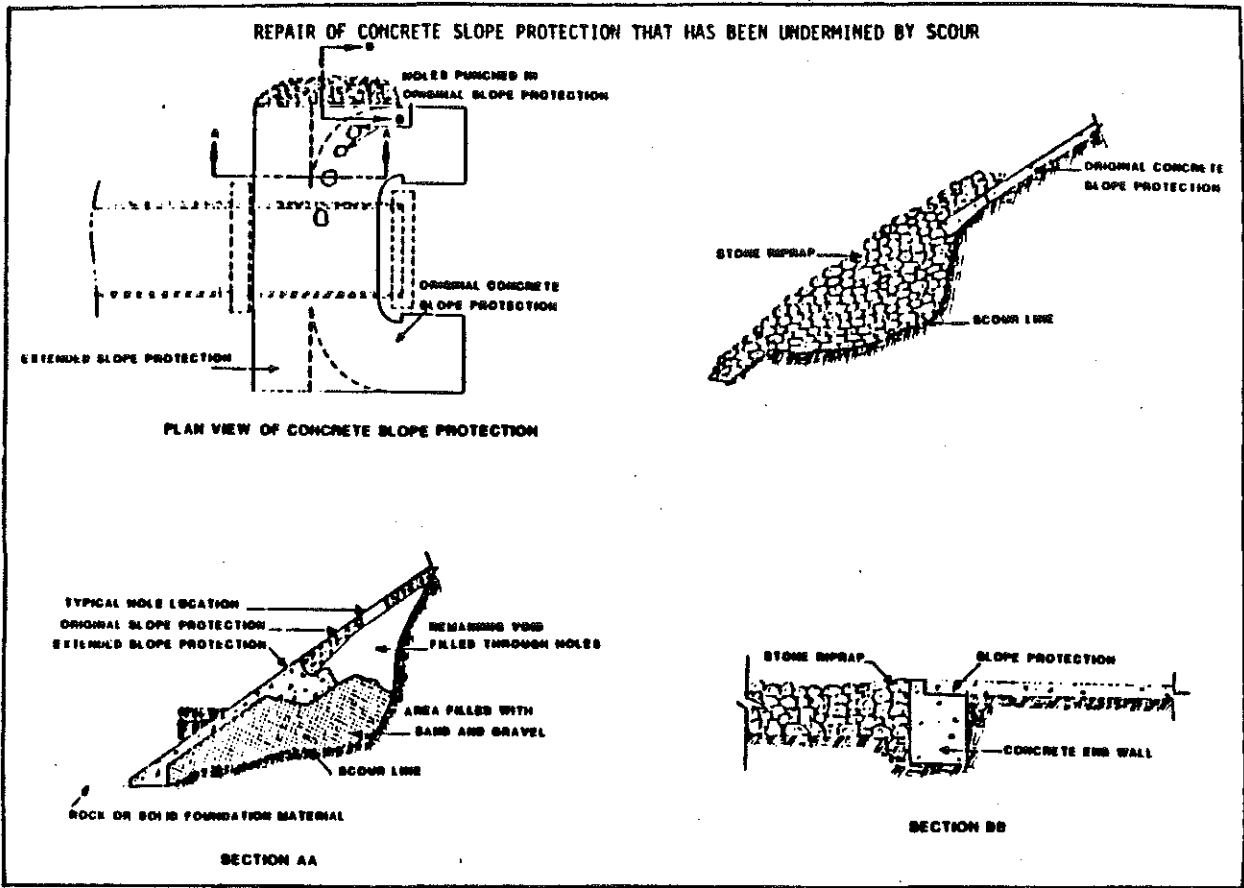

Figure 38. Illustration of Foundation Repair Procedures for Scour-Related Damage.





**Figure 38. Illustration of Foundation Repair Procedures for Scour-Related Damage.**



**Figure 38. Illustration of Foundation Repair Procedures for Scour-Related Damage.**

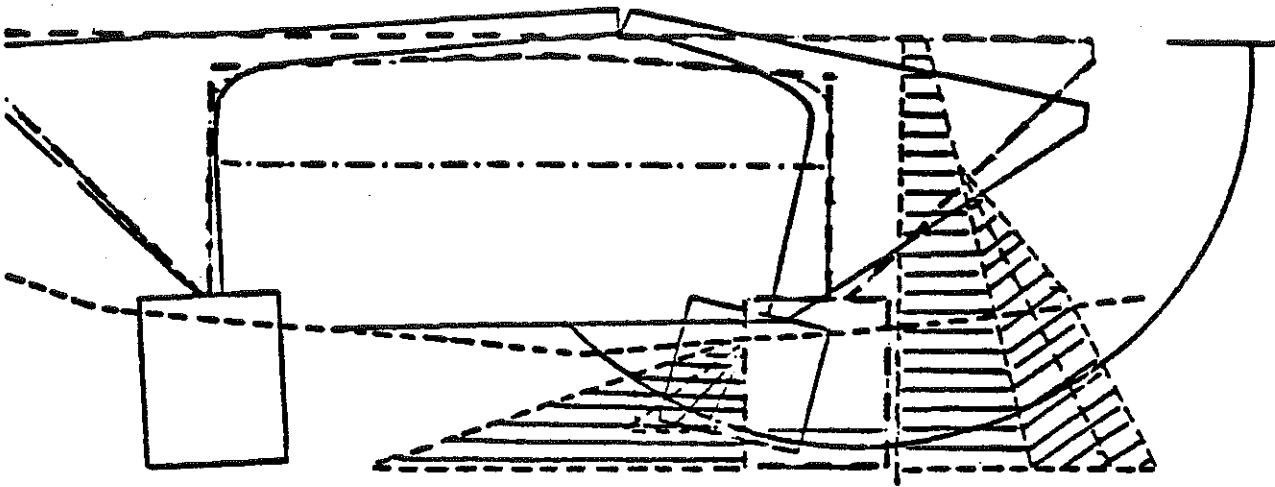

Figure 39. Illustration of Bridge Foundation Failure Resulting from Increased Water Content.

The first commercial steel-making process was developed in Kentucky by Homer Kelly in the 1830's. By the turn of the century, steel had replaced wrought iron as the most important structural metal. This was because steel was twice as strong as wrought iron.

Structural steel contains a little carbon (less than one percent) dissolved in iron. Small amounts of other elements such as sulphur, manganese, and phosphorous also are found in steel.

Steel is produced in various mixtures of elements -- called alloys. These alloys have different purposes and strengths. In general, all steel plates and beams used in bridges should be made from alloys meeting American Society for Testing and Materials (ASTM) specifications. Typical steel alloys covered by those specifications are ASTM A36 (low-carbon steel) and ASTM A572 (low-alloy steel). Other steels meeting specifications of the Society of Automotive Engineers (SAE) or the American Iron and Steel Institute (AISI) may be used where failure is not life-threatening.

Steel is very strong and provides good resistance to tensile and compressive loads. Wrought iron is fairly strong (compared to steel) in tension and compression. Cast irons, however, can resist only compression loads.

### ***2.7.1 Steel Shaping and Joining***

Steel can be easily shaped when heated. At room temperatures, it may be cold bent when the shape is thin. Also, it may be machined (drilled, planed, sheared, milled, sawed, lathed, and threaded). Steel also may be cut and bent with the assistance of an oxy-acetylene torch.

Both steel and wrought-iron pieces may be assembled readily by use of mechanical fasteners such as bolts and rivets. Holes may be made for those fasteners by drilling or punching. Usually, this should be done using undersized drills or punch-and-die sets. Then, the hole wall should be finished with a reamer to improve its finish. Riveting is not widely used today, and it is recommended to use bolts instead.

Bolts and nuts used in bridges should meet ASTM Specifications A325 or A490 (high-strength) (Figure 40). Such fasteners are furnished with either a galvanized (hot-dipped or mechanical) or black phosphorized finish. The galvanized finish does not need to be painted after installation. However, the phosphorized coating is not durable and the bolts and nuts should be painted after they are installed.

Bridge bolts are usually used in friction connections (Figure 41a). The bolts are tightened to force a splice plate against two mating pieces. Another type of connection is the direct-bearing connection (Figure 41b). However, direct-tension connections should usually be avoided.

In the friction connection, the amount of tightening of the bolt against the washer is very important. The proper torque may be obtained several ways: 1) by a torque wrench, 2) by the "turn-of-the-nut" method, or 3) by the use of load-indicating washers. A torque wrench is used to obtain known torque (rotating force) measurements in foot-pound (a product of the lever arm used in tightening the bolt and the force applied against it). The turn-of-the-nut method requires that the nut be firmed up to tighten the mating pieces. Then, the nut is backed off the bolt and snugged loosely until the nut cannot be tightened by

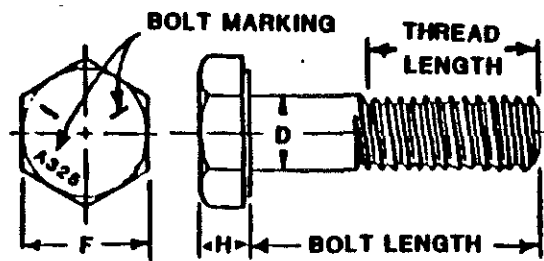
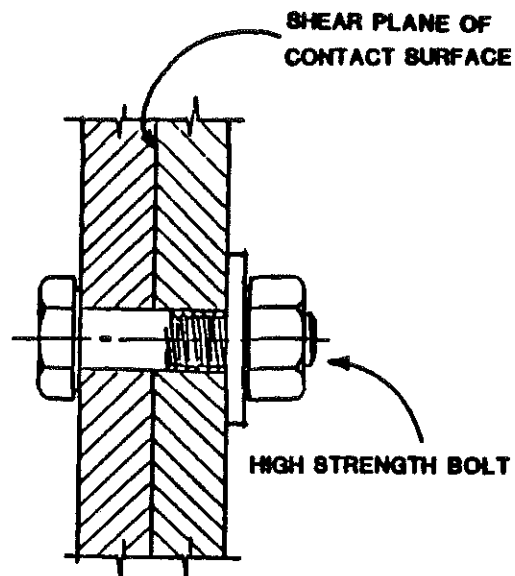

Figure 40. Typical ASTM Bolt and Installation.

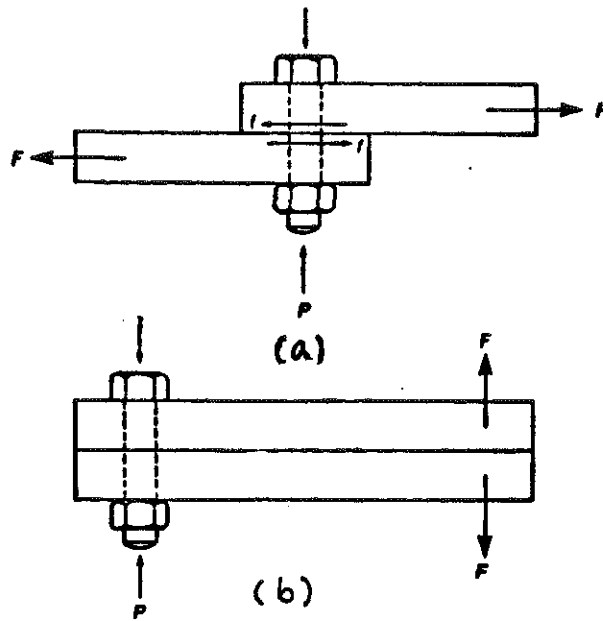

Figure 41. Bolted Connections: (a) Shear Connection and (b) Direct Tension Connection ( $P$  = Bolt Clamping Force and  $F$  = Applied Force).

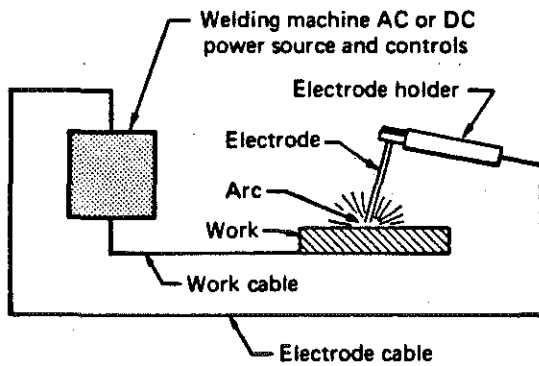

Figure 42. Electric Circuit for Arc Welding.

hand any further. Then, the nut is rotated usually 1/3 to 1/2 turn from that point. Load-indicating washers have small protrusions that are mashed as the nuts or bolt heads compress them during tightening. The gap between the washer and the nut or bolt is measured to determine the proper amount of tightening.

Regardless of the type of bolt tightening used, washers always should be placed between the bolt head or nut and the workpiece.

The other way of joining steel, wrought iron, and even cast iron is welding. Manual shielded-arc welding is the most common method used for maintenance welding. Welding is really a miniature casting process.

In arc-welding, the workpieces are electrically charged (Figure 42). The consumable welding electrode is given an opposite charge. Then, it is tapped against the workpiece to start a flow of electricity between the workpiece and electrode. The electrode is rapidly pulled away from the workpiece, causing an arc to strike. The arc melts both the electrode and the surface of the steel. The melted steel rod in the electrode is transported down the arc to the workpiece where it acts as a filler metal mixing with the melted metal from the workpiece.

The melted metal freezes and forms a single workpiece joined by the weld. The welder rapidly moves the electrode down the joint between the workpieces forming a single piece as it is being consumed (melted). Usually, more than one weld pass must be made to complete the weld. When this occurs, the joint between the workpieces are grooved to make welding easier. Between each pass, the welder should chip away the slag that covers the weld. This protective material is coated on the electrode and melts along with the center steel rod. The coating should never be disturbed and should be kept dry and clean prior to the welding. After the slag is completely removed by chipping with a pointed hammer, the next weld pass can be deposited.

On finishing the weld and prior to painting, all slag on the surface of the weld should be removed. In some cases, it may be desirable to grind the extra weld metal flush with the surface of the workpiece. Typical welds are 1) fillet welds, 2) butt welds, and 3) plug welds (Figure 43).

Welding electrodes are made to meet American Welding Society (AWS) specifications such as E60XX and E70XX (where the first two numbers represent the strength of the weld metal and the remaining numbers the welding characteristics of the electrode. On most off-system bridges, low-strength steels such as ASTM A36 steel are used; these may best be welded using the E60XX series electrodes.

Many early bridge steels were not formulated to for allow welding. Those steels along with the early ASTM A7 steels should be welded with an electrode classified as low-hydrogen, such as E7016. However, those decisions should be made by an experienced welder or, in the case of non-specification steel, to a welding engineer. Low-alloy steels such as ASTM A441 and A588 should be welded with E70XX electrodes having low-hydrogen properties. Care should be taken when welding different types of steels together or when welding SAE and AISI alloys having designations above 1030. Generally, AWS electrodes are well matched with ASTM structural steels.

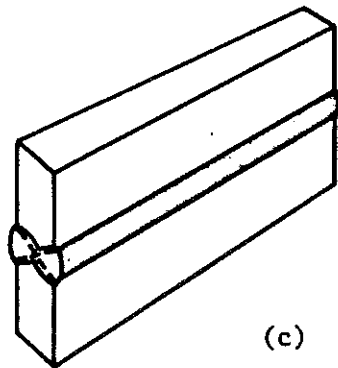
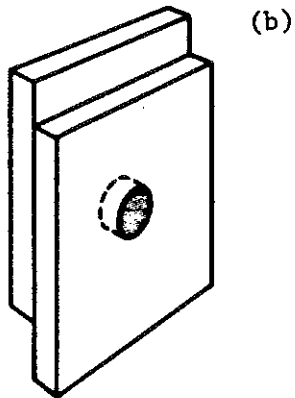
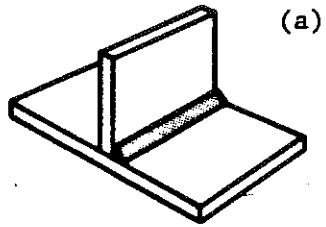

Figure 43. Common Types of Welds: (a) Fillet Weld, (b) Plug Weld, and (c) Groove (Butt) Weld.



Welds, especially those in the field, should be performed carefully by experienced personnel. Care should be taken to clean surfaces to be welded. Joints, especially those thicker than 3/8 inch, should be grooved to make the weld easier to complete. The workpiece may need to be preheated prior to welding. Also, cold or wet weather or high winds may hamper field welding. It may be necessary to enclose the welded area to shield it from the weather. It is best never to weld in rain, in wind above 5 mph, or when temperatures are much below 70°F. Also, never weld on a bridge under traffic.

Any field repairs of cracks require very knowledgeable, skilled personnel and perhaps a welding engineer as a supervisor. This should be avoided and the cracks should be lapped with bolted splice plates when necessary.

Using an oxy-acetylene torch, steel bars or plates may be heated to a red color and bent to useful shapes with little danger of cracking. Also, a good torch operator can cut complex shapes from plate. A normal operator may use guide devices to obtain almost saw-cut finished parts. Tempering of parts, except for tools, by dipping hot steel in water is a tricky proposition and should be avoided.

Cast iron and wrought iron may be welded by knowledgeable, skilled welders. Cast irons are brittle and crack easily when welded. However, certain welding "tricks" combined with the use of high-nickel electrodes will provide reliable welds. Wrought iron may be welded with some of the E60XX electrodes. Again, some welding tricks are needed to produce good welds.

Once an important structural weld or repair weld is completed and cooled for several hours to room temperature, it is desirable to perform a nondestructive test on the weld to detect the presence of any cracks. The easiest way to do this is to use the dye-penetrant test. A red dye is placed on the surface of the weld and will be drawn into any cracks. The excess surface dye is wiped off and a white developer solution is placed on the weld. The developer will pull the red dye out of the crack and it will appear as a red line on the white developer background. The crack may then be repaired. Other more thorough nondestructive test methods may be required on large welds. An engineer may recommend when those methods should be employed.

Steel is available in a wide variety of shapes and forms useful for bridge applications. Usually, those pieces may be obtained easily from regional steel wholesalers or steel companies. Useful shapes include 1) "I" and "W" beams (for use as stringers); 2) "S" and "T" shapes for bracing; 3) "H" shapes for piles; 4) deformed bars and wire mesh for concrete reinforcing; 5) plates, rods, and bars for a variety of uses; and 6) grating for bridge decks. Additionally, welded girders and other finished shapes may be obtained to meet specific requirements.

### ***2.7.2 Problems with Steel Bridge Members***

Steel bridge members are subject to several common problems, corrosion and cracking, which need to be closely monitored. Corrosion is the most common problem and may lead to a weakened structure if not treated. Cracking may cause failure of the bridge and may lead to loss of life.

Steel may corrode readily when exposed to the weather. Corrosion is due to a complex electric-chemical reaction that involves oxygen and water usually in the form of atmospheric moisture. Also, the presence of deicing salt accelerates corrosion. Corrosion converts the surface steel to a crusty red material called rust (iron oxide). Rust attracts more moisture and traps salt, further promoting the process. If not treated, the corrosion will eventually consume more and more steel. One result is obvious. As the piece becomes thinner, its capacity to bear load decreases. Therefore, some point will be reached when the remaining steel will be unable to bear the load and the structure will fail. An excellent way to fix a rusted steel member is to remove the rust and protect the metal from further corrosive attack. The member also may be replaced.

Cracking of steel is usually not an immediate problem with steel bridges, but is due to a phenomenon called fatigue. To understand fatigue, bend an arm of a paper clip back and forth until it breaks. No single bend (load) is enough to break it, but all the bends add to a condition that cause the clip to break. The same thing may occur on a bridge. Many loads may form a crack and cause it to grow to a size that will cause the structure to fail.

Crack growth is usually a very slow process and often may be detected by close visual inspection. Also, it only occurs on members of the bridge subject to tensile load or on tension portions of flexural members. Fatigue-crack growth would not occur on the upper flange of a simple span for example. Usually, a fatigue crack will appear as a rusty line on the surface of the structure. The biennial KYDOH inspections are expected to be sufficient to detect fatigue cracks. However, they may not be detected. One should have a good idea of the appearance of cracks, so they may be recognized in case they exist. Usually, cracks occur near welds, rivet and bolt holes, and points of sharp material change such as inward corners in the material. Crack growth may usually be halted by drilling a hole at the end of the crack tip. The diameter of the hole should be at least twice the thickness of the cracked material. If a crack is detected in one location on a bridge, other similar locations should be checked for possible fatigue cracks.

## **2.8 PAINTS**

Paints are thin coatings applied to steel and iron bridge components to protect them from corrosion and to improve their appearance. Paint begins as a liquid, which is converted to a solid film after it is placed on a metal surface. Paints consist of two components, a vehicle and a pigment. The vehicle is the liquid portion of the paint. Much of it evaporates after the paint is applied. The pigments are small solid particles. They provide the paint its color and protective properties.

Paint should include the surface preparation, pretreatment, paint application, primer, intermediate coat, and finish coat. All factors should be coordinated or the paint may fail.

Paint should be applied to a dry, clean surface that has been slightly roughened. The surface may be tightly adhering old paint, mill scale, or freshly cleaned metal. The surface may be prepared by scraping, wire brushing, dry-sand blasting, flame-burning, steam cleaning, water blasting, or chemical treatment. Water-based grit blasting is the preferred method.

After the metal surface is cleaned, the paint can be applied by brushing, rolling, spraying, or mopping. The best method relates to how much metal is being painted and to its shape.

The quality of a paint is related to the final thickness of the dried paint (plus its adherence to the metal). When the vehicle dries, the quantity of pigment in the original paint determines the thickness of the dried layer. Since there is a limit as to how much paint should be applied in one coating operation, several coats or successive paint applications are required to build a paint coating to the required thickness.

The layers of the paint system may consist of different types of paint. Each type of paint in the system may have a specific purpose. Primers are usually good for holding onto the metal surface and protecting it from corrosion. An intermediate coating might be used to serve as a water or chemical barrier. A third or outer coating might have good resistance to sunlight and abrasion.

It should be noted that paints are durable, but not permanent. When a bridge is painted, it is hard to determine how long it will last. This depends upon many things. Usually, one could expect a bridge paint job to perform adequately about 10 years. However, some components may begin rusting in just a few years.

### **3.0 MAINTENANCE FUNCTIONS**

Bridge and culvert maintenance operations may be divided into three basic categories: 1) routine maintenance, 2) periodic maintenance, and 3) major or emergency maintenance. Routine maintenance should be anticipated and planned. Periodic maintenance may be anticipated, but often cannot be closely planned. Emergency maintenance is impossible to anticipate or plan.

#### **3.1 INSPECTION, RATING, AND POSTING**

The task of conducting biennial inspections, rating of structures (bridges), and posting of load limits may be the responsibility of the local government or of the Department of Highways (by agreement). Often the KYDOH will inventory, inspect, analyze, and provide posting limits for local officials. Therefore, a person dealing with bridges should get to know the KYDOH bridge inspectors and establish a good working relationship with them.

It is important to obtain bridge ratings that are realistic so that load postings reflect the true strength of a structure. Those ratings may be used to plan future work and determine funding needs. Also, proper load postings will prevent conflicts that might arise due to problems with those who want to keep a bridge open or who desire to impose heavy loads that exceed the posted limit.

Bridge inspections conducted by the KYDOH will be furnished to local officials in the Structural Inventory and Appraisal (SI&A) reports. A summary of the SI&A forms has been included in the Appendix for reference. That information was extracted from the workbook used for training of bridge inspectors by KYDOH. Note that presently, by federal law, all bridges are to be inspected, not just bridges on federal routes.

Structural analyses will be made by KYDOH personnel to determine the maximum safe load a bridge can tolerate. Thereafter, the bridge should be posted according to its safe limits. Posting will be done by KYDOH in terms of safe typical two-axle and semi-trailer configurations (Figure 44). When the structural capacity of the bridge exceeds the limits for H-20 (two-axle) and HS-20 (semi-trailer) trucks, the bridge will not be posted. However, when the rating is less than that, the bridge will be posted by signs to inform motorists of load limits. When the bridge is rated at 3 tons, trucks will be prohibited from using the bridge. No bridge will be posted for a load capacity of less than 3 tons. Weaker bridges must be rehabilitated or closed.

The posted limit will be on a sign located in close proximity to the bridge. It is in the local official's best interest to make sure the sign remains in place, is visible, and is in good condition.

Bridge officials may experience some pressure to request that the posted limits be revised (usually upward). The KYDOH engineer is placed in a difficult position, for he cannot rate a bridge stronger than the structural analyses indicate. On some bridges, it is possible to make relatively inexpensive structural improvements. This is a better option than trying to wrangle a structural upgrade from the KYDOH district bridge engineer. A bridge may be badly damaged or deteriorate quickly when heavily loaded.

**HS20 TRUCK LOAD**

20 Tons

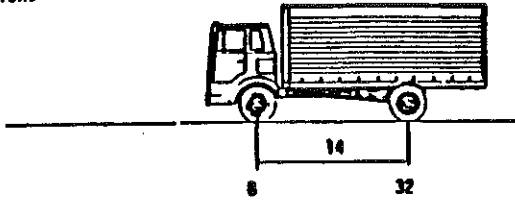

**HS20 TRUCK LOADING**

36 Tons

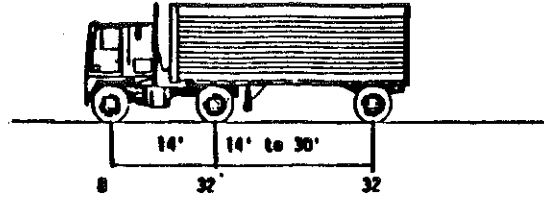

**HS20 LANE LOAD**

20 Tons

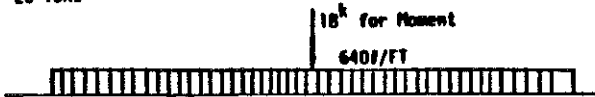

**SINGLE VEHICLES**

**HS20 LANE LOAD**

36 Tons

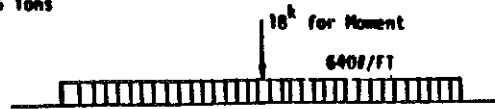

**COMBINATION VEHICLES**

Figure 44. Standard Truck Loads.

A good, accurate inspection by the KYDOH inspector is a reasonable expectation. However, the inspector should not be expected to perform other tasks. He is only looking at the structure every two years. If possible, the local official responsible for bridges should inspect structures each year. He should take the KYDOH SI&A report with him and compare his inspection results with those of the KYDOH inspector. If differences are observed, the inspector should be contacted and asked to explain the bridge rating. Sometimes, as in the case of a sudden slope failure, the local bridge official may notice structural damage that may not be detected by the infrequent KYDOH inspection.

If time is short, the local bridge official can at least drive slowly over the bridge and observe the condition of the approaches, the deck, guardrails, superstructure, and signing. He might find a reason to stop and look over the whole bridge or look at a potential problem.

### **3.2 ROUTINE MAINTENANCE FUNCTIONS**

Some maintenance tasks should be conducted routinely, such as inspecting bridges and culverts. Other tasks, such as cleaning the gutter lines on a bridge deck or cleaning out bridge drains, also should be completed routinely. Spot-painting of steel bridges also can be made part of routine work for a field crew. Tasks for bridge officials would include scheduling of crew work assignments and inspection of their work.

### **3.3 PERIODIC MAINTENANCE FUNCTIONS**

Some tasks will be periodic in nature. Salting of bridge decks and a spring cleaning to remove leftover salt would be a good example. Other periodic functions would be cleaning stream beds of debris or repairing damage due to spring flooding. Clearing expansion joints of debris can be made an annual task. Maintenance of bearing assemblies also can be made an annual task. Other periodic tasks would include preparation of annual budgets, equipment purchases, and personal reviews.

### **3.4 MAJOR AND EMERGENCY FUNCTIONS**

Major and emergency functions include repair of bridges damaged or collapsed due to accidents or structural failure. Other major functions would include painting of an entire bridge or a structural change such as widening or reinforcing a bridge. Repair of a slope failure, mud-jacking of an approach span, or repair of scour of pier would be substructure-related major or emergency functions. Replacement or overlayment of a bridge deck also would be considered a major task. Interacting with contractors, consulting engineers, and state officials would be personal tasks related to major and emergency work.

## **4.0 SERVICE-RELATED DETERIORATION**

If loads and weather did not cause bridges and culverts to deteriorate, there would be no need for a maintenance function. In that respect, deterioration can not be all bad. However, a problem does exist when a local official tries to satisfy all the needs on an inadequate budget normally available.

### **4.1 WATERWAYS AND TERRAIN**

#### **4.1.1 Scour**

Scour, the erosive action of running water in streams, results in the excavation and carrying away of material from the streambed and banks. Scour can occur in both soil and rocks, but perhaps is more prevalent in soil. Scour frequently is observed around piers and abutments of bridges as well as around culvert inlets and outlets.

Scour may be subdivided into four categories: scour that occurs in the stream itself, with or without a bridge or culvert structure; scour that occurs at a bridge or culvert site because of contraction of the stream flow, which increases the velocity (speed) to greater than normal; scour that occurs because the course of the stream has been altered by the location of bridge piers or abutments or by the location of a culvert; and scour that results because of any combination of the above.

The amount of scour depends upon the size, shape, and orientation of the obstruction (pier, abutment, or culvert), and the flow pattern of the stream.

#### **4.1.2 Degradation and Aggradation**

Degradation is a form of scour resulting from the reduction of sediment supplied to a specific area as might result when the streambed is lowered because of a dam or other upstream flood control structure. Conditions that may result in degradation include channel drops and spillways in the vicinity of the bridge or culvert, changes in the underpinning of existing structures, changes in the streambed elevation over a period of time, and/or shifting of the channel downstream causing a lowering of the streambed. Degradation often is observed near footings, and piles may become exposed below the footings.

Aggradation is the opposite of degradation. Aggradation is the deposition of sediment in river channels. This action results in the raising of the water surface because of a rise in the elevation of the streambed. The rise in the water surface could result in a buildup of deposits on the lower components of the bridge. This buildup may restrict the water flow under the bridge and increase the potential for deposition of sediment upstream. Deposition in the river channel also can result in a greater flood flow encroaching on the floodplain, which in turn could result in added local scour at a constricting bridge.

#### **4.1.3 Debris**

Debris is classified as small, medium, or large, depending upon the size of the vegetation washed up along the banks and trapped against piers and abutments. The size of debris is an important consideration when evaluating the adequacy of bridge clearance. For instance, undercut banks with large trees near the edge can create a potentially hazardous situation for a downstream structure.

#### **4.1.4 Ice Damage**

Ice is a unique form of debris that should be considered in regions where ice floes may occur. Historically, ice has not been a significant problem in Kentucky. In those areas where ice is a potential problem, the scarring on tree trunks and structures may be an indication of potential damage.

#### **4.1.5 Dredging of a Channel**

Dredging of a channel, either upstream or downstream, may produce increased velocities of stream flow that may cause damaging scour or erosion along the waterway, especially in the vicinity of bridges or culverts.

#### **4.1.6 Flood Damage**

The discharge and velocity of stream flow is much greater during floods than under normal conditions. Floods have the capacity to transport large sediment loads and can result in significant erosion. Erosion and scour associated with floods are major problems. The deposition of sediment during flooding also can result in significant problems. Erosion and deposition (separately and collectively) can change stream flow characteristics and result in significant problems in the vicinity of bridges and culverts.

#### **4.1.7 Terrain Problems**

Streambed erosion is a problem in nearly every part of the country. Not only does erosion leave ugly scars on the landscape, it also reduces the productivity and/or recreational value of land. Erosion can cause clogging of stream channels by depositing large quantities of silt and other fine materials taken from fields and stream banks. Abutments, piers, and retaining walls frequently are damaged by excessive erosion. The extent and severity of erosion is determined by soil type, the size and character of floods, the presence or absence of trees or shrubs, velocity of stream flow, the stability of the river bed, and climatic conditions. The amount of material eroded by a stream varies greatly depending upon the terrain over which it flows and the characteristics mentioned above.

#### **4.1.8 Construction Activities**

Construction activities can increase the scour potential at new and existing structures. Channel changes, removal of streambed material by dredging, large coffer dams, and temporary ramps into the



stream may produce unanticipated scour. Such action can lead to an increasing possibility of floods and impeded navigation.

## **4.2 SUBSTRUCTURE PROBLEMS**

The total weight of any structure plus any loads carried by the structure must be supported by the underlying foundation materials (soil and/or rock). The foundation is therefore an invisible but highly critical component of the structure. The substructure of a bridge has been defined as those components of the bridge structure that transfer loads from the bridge span to the ground.

### **4.2.1 Common Substructure Elements**

Common substructure elements are abutments and piers. Abutments typically consist of a footing (spread or pile footing), a breast wall, a bridge seat, a backwall, and wing walls (Figure 45). The bridge seat is the horizontal segment on which bridge bearings are situated. The back-wall prevents embankment soil from spilling onto the bridge seat. Wing walls prevent embankment material from spilling into the waterway or roadway being spanned. Some abutments may be designed to allow embankment material to spill through the front of the abutment below the bridge seat. The design of abutments is an engineering consideration that requires a unique solution for each specific site.

The main elements of bridge piers are footings, columns, and caps (Figure 46). Footings may be spread, pile, or drilled shaft (Figure 47). If piles extend to the cap, the term bent instead of pier is used to describe the element. Columns transmit vertical load and movement to the footing. A single wall column is sometimes referred to as a solid wall pier. If a pier consists of a single column, it is referred to as a stem. A cap is the beam that binds individual columns into a single unit. The cap distributes the loads from the bridge bearings to the columns. Piers may be constructed of concrete, steel, or stone. Bents and/or piles may be constructed of wood, steel, or concrete. Piers for structures spanning waterways generally are more massive than piers for structures used for roadway underpasses. Starlings (pointed noses) also are used on waterway piers to reduce the force of water and/or debris against the piers.

### **4.2.2 Substructure Failures**

Failures due to flooding account for approximately one-half of all bridge failures. Generally, a flood can destroy more than one bridge at the same time. Flooding related failures may be connected to two failure mechanisms: scour and debris. Brittle failures of steel bridges is perhaps the second most common failure mechanism. Bridge failures associated with collisions by ships or motor vehicles has been increasing in recent years. Earthquakes and wind also have caused bridge failures. Corrosion and/or fatigue are other factors that have been associated with bridge failures.

Substructure failures most often are associated with a failure of the foundation supporting the substructure (Figure 48). Failure of the foundation prevents the substructure from performing the designed

task of distributing and transferring loads from the superstructure to the foundation. Substructure failures most often are related to scour and the over-accumulation of debris from flooding conditions. Earthquake forces also may contribute to a loss of foundation support and a failure of the substructure. Failure of the substructure nearly always results in failure or damage to the superstructure.

#### **4.2.3 Abutments and Abutment Failures**

Abutments may be grouped into three categories (Figure 49): full-height; closed, stub, semistub, or shelf; and spill-through or open.

Full-height and stub abutments extend from the gradeline of the roadway or waterway below to that of the road overhead. A stub will be located within the topmost portion of the end of the embankment or slope. Semi-stub or shelf abutments are supported on piles driven through the embankment. Spill-through or open abutments rest on a column or columns.

Abutment problems can be categorized on the basis of the type of movement associated with the failure or problem. Past experience has indicated the following problem areas:

- a. tipping or a rotational movement,
- b. sliding or lateral movement,
- c. settlement or vertical movement, and
- d. failure of abutment materials.

Tipping or rotational movement typically is associated with scouring, backfill material saturated with water, or erosion of the backfill alongside the abutment.

Sliding or lateral movement of the abutment may result because of slope failure, seepage and excessive moisture in the foundation and backfill material, changes in characteristics of soil, and consolidation of the original soil.

Vertical movement of an abutment generally results from settlement or expansion at the abutment. Causes include soil-bearing failure, soil consolidation, cracks, insect attack, or fungus attack.

Failures of abutment materials are the result of defects in concrete, masonry, steel, or timber. The causes of defects are debris, standing water, bridge drainage, mortar cracks, missing stones, insect attack, scour, and fungus attack.

#### **4.2.4 Dolphins and Fenders**

Dolphins are clusters of piles with protective caps. Piles are jointed together at their top ends around a center pile with wire or bolts. Dolphins may be constructed of timber or steel piles. Steel tube clusters or steel sheet piles also may be used.

Fendering systems are one of the most important protective systems used to guard bridge elements from waterborne traffic. The basic types of fendering systems in existence today are floating fender or camel, timber-pile systems, retractable fender systems, rubber-in-compression systems, gravity fender systems, hydraulic fender systems, and steel spring systems.

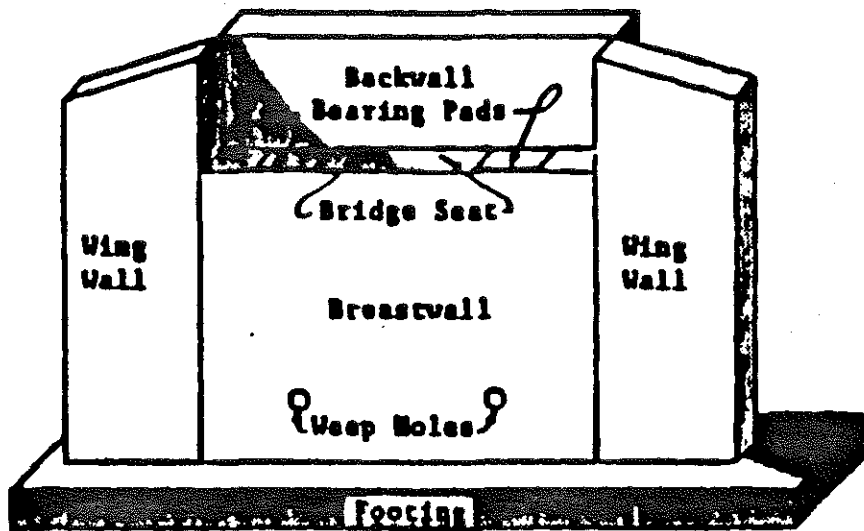
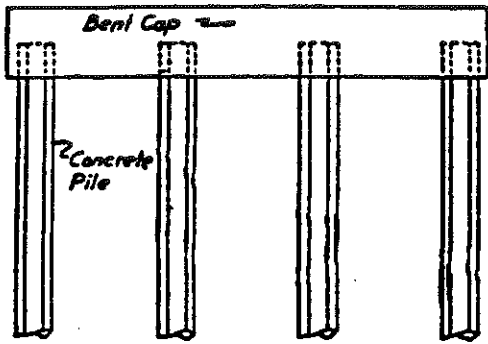
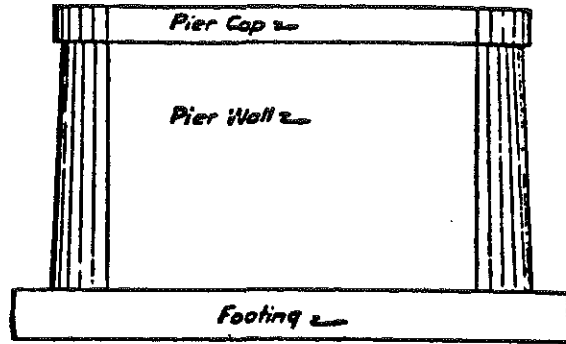

Figure 45. Elements of an Abutment.



PILE BENT



SOLID PIER

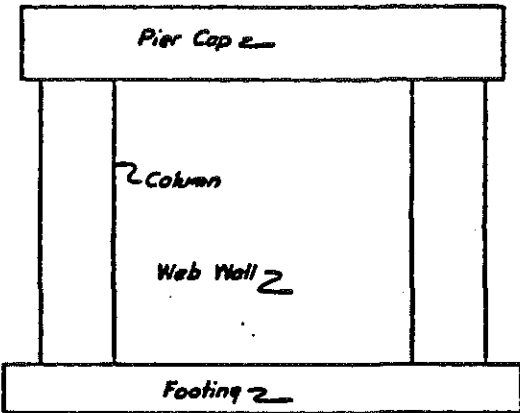

COLUMN PIER WITH SOLID WEB WALL

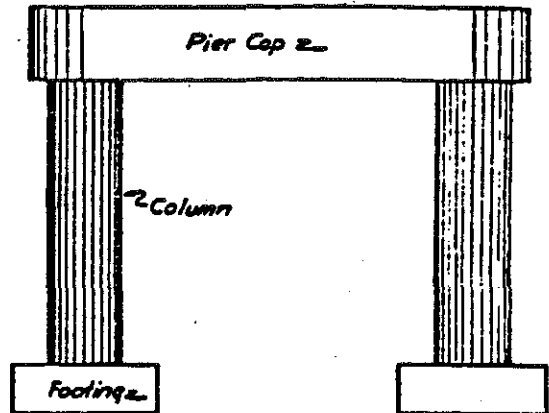

OPEN PIER

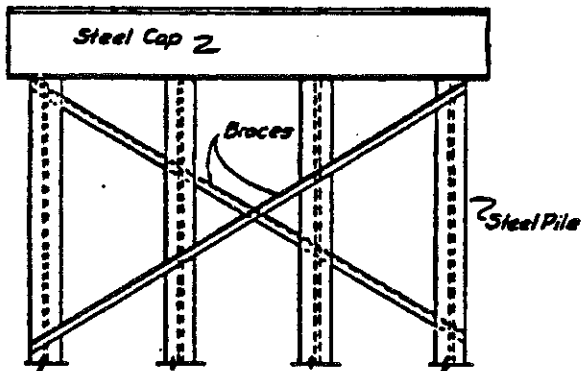

STEEL BENT

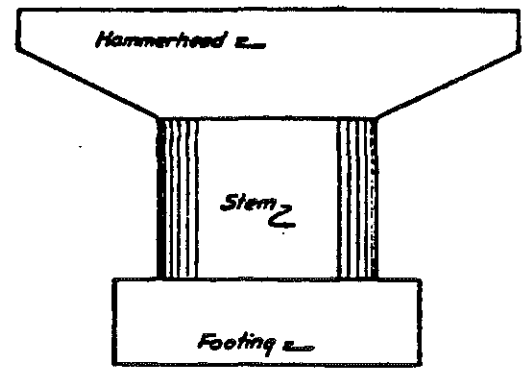

CANTILEVER PIER OR HAMMERHEAD PIER

TYPES OF PIERS

Figure 46. Elements of Bridge Piers.

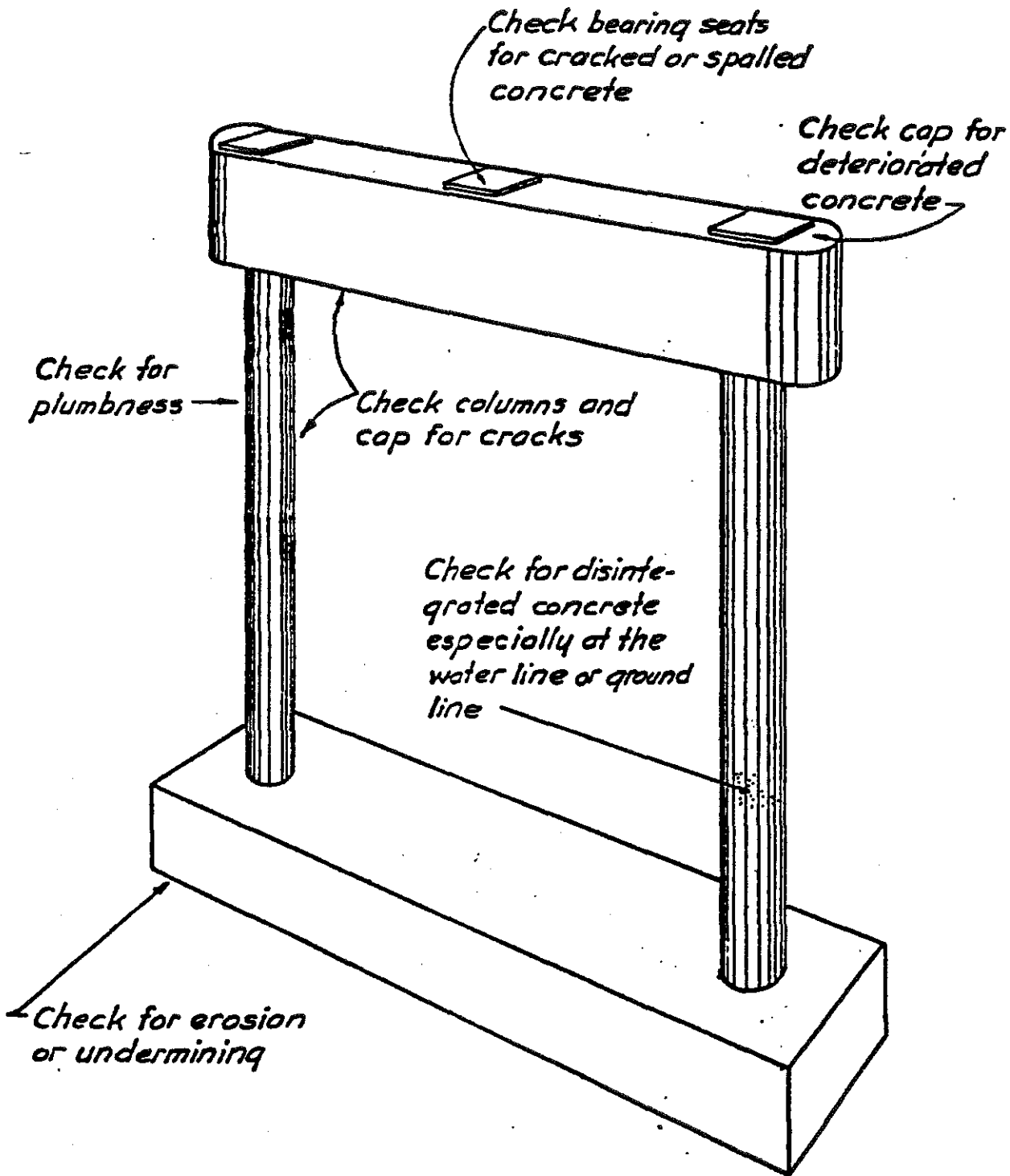

**CONCRETE PIER AND BENT CHECKLIST**

Figure 46. Elements of Bridge Piers.

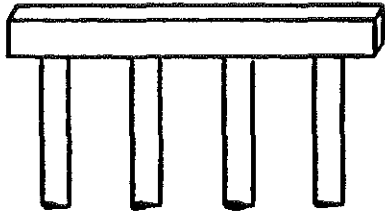

**PILE BENT**

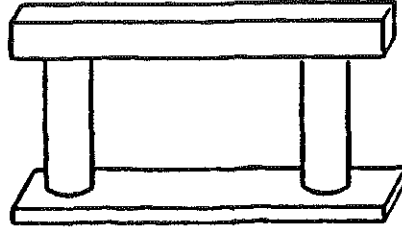

**COLUMN BENT OR OPEN PIER**

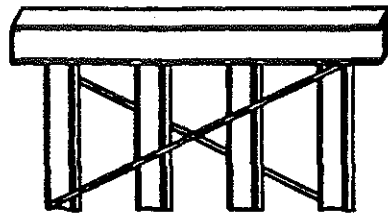

**STEEL BENT**

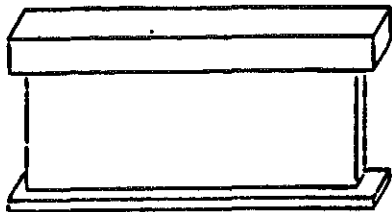

**WALL OF SOLID PIER**

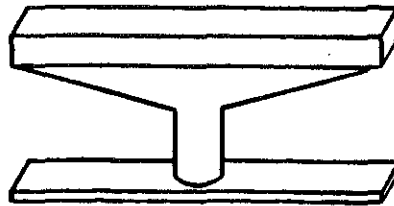

**HAMMERHEAD PIER**

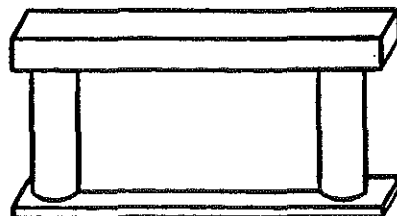

**DUMBBELL PIER**

**Figure 47. Typical Bridge Piers and Footings.**

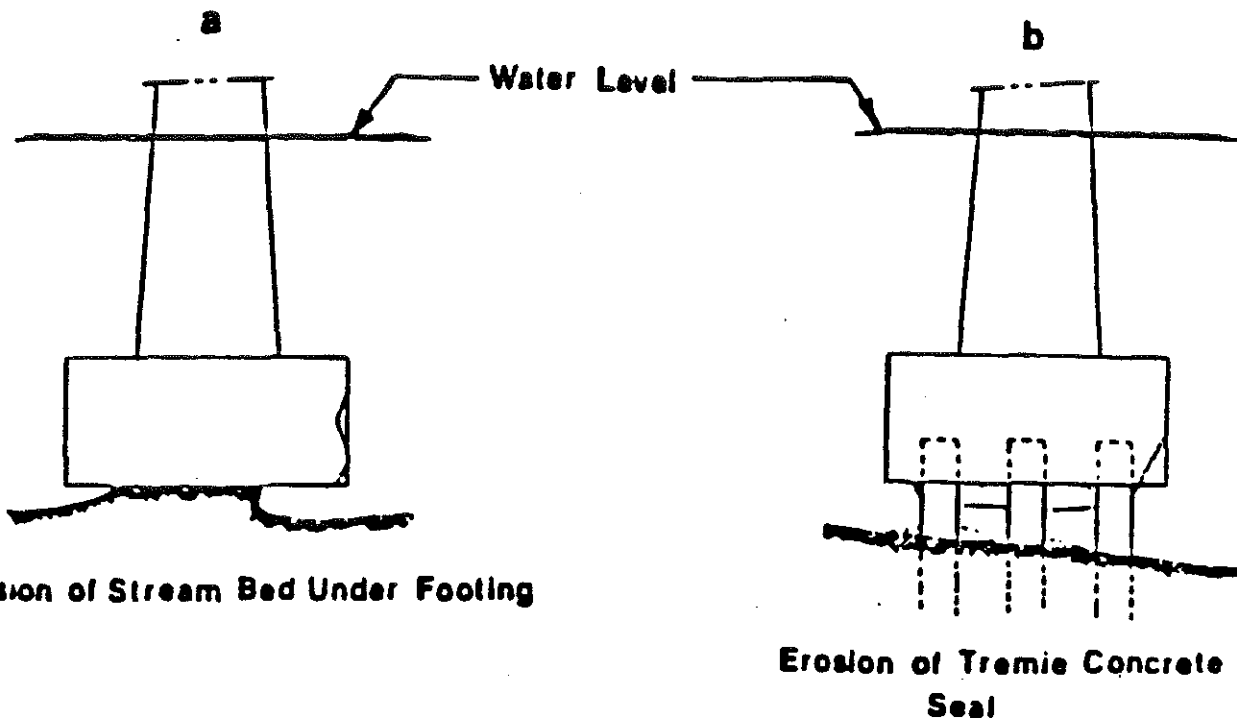

Figure 48. Distress Conditions at Pier Footings.

### **4.2.3 Abutments and Abutment Failures**

Abutments may be grouped into three categories (Figure 49): full-height; closed, stub, semistub, or shelf; and spill-through or open.

Full-height and stub abutments extend from the gradeline of the roadway or waterway below to that of the road overhead. A stub will be located within the topmost portion of the end of the embankment or slope. Semi-stub or shelf abutments are supported on piles driven through the embankment. Spill-through or open abutments rest on a column or columns.

Abutment problems can be categorized on the basis of the type of movement associated with the failure or problem. Past experience has indicated the following problem areas:

- a. tipping or a rotational movement,
- b. sliding or lateral movement,
- c. settlement or vertical movement, and
- d. failure of abutment materials.

Tipping or rotational movement typically is associated with scouring, backfill material saturated with water, or erosion of the backfill alongside the abutment.

Sliding or lateral movement of the abutment may result because of slope failure, seepage and excessive moisture in the foundation and backfill material, changes in characteristics of soil, and consolidation of the original soil.

Vertical movement of an abutment generally results from settlement or expansion at the abutment. Causes include soil-bearing failure, soil consolidation, cracks, insect attack, or fungus attack.

Failures of abutment materials are the result of defects in concrete, masonry, steel, or timber. The causes of defects are debris, standing water, bridge drainage, mortar cracks, missing stones, insect attack, scour, and fungus attack.

### **4.2.4 Dolphins and Fenders**

Dolphins are clusters of piles with protective caps. Piles are jointed together at their top ends around a center pile with wire or bolts. Dolphins may be constructed of timber or steel piles. Steel tube clusters or steel sheet piles also may be used.

Fendering systems are one of the most important protective systems used to guard bridge elements from waterborne traffic. The basic types of fendering systems in existence today are floating fender or camel, timber-pile systems, retractable fender systems, rubber-in-compression systems, gravity fender systems, hydraulic fender systems, and steel spring systems.

The floating fender or camel system consists of horizontal and/or vertical timber members bolted to the wharf structure. The timber pile system employs piles driven along a wharf-face bottom. Pile tops may or may not be supported laterally. Steel and concrete piles also may be used.



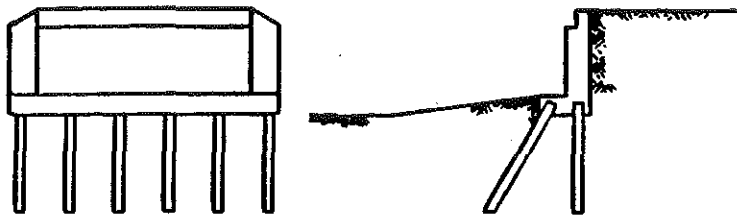

**SEMI-STUB ABUTMENT**

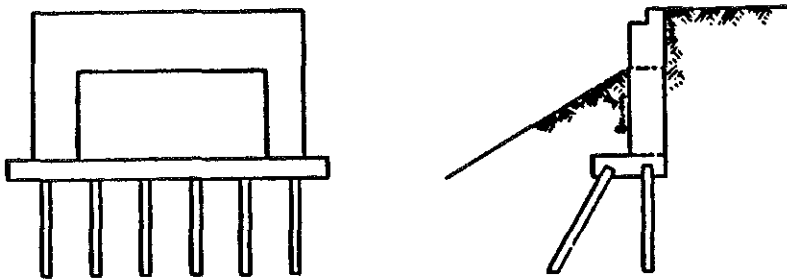

**SPILL-THROUGH ABUTMENT**

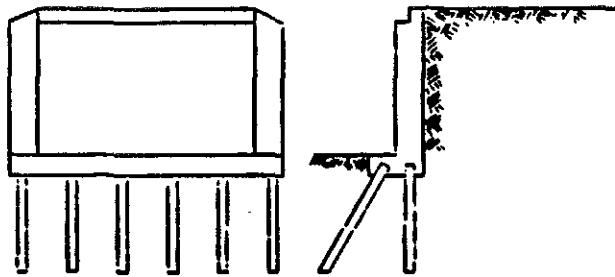

**FULL HEIGHT (SHOULDER) ABUTMENT**



**STUB ABUTMENT**

Figure 49. Typical Abutments.

Full-Height or Closed Abutment

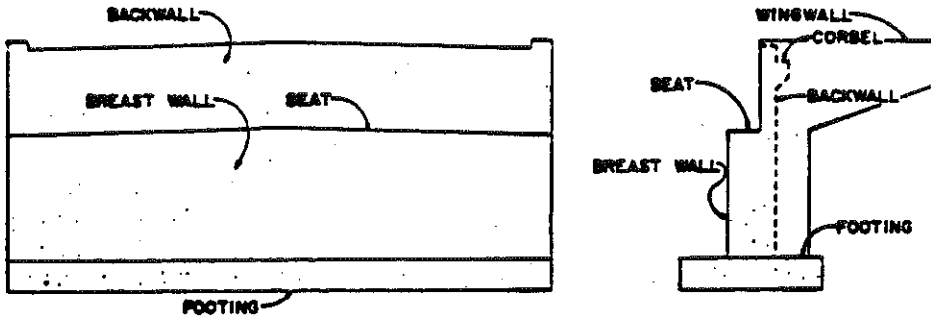

FULL RETAINING TYPE ABUTMENT

Stub, Semi-Stub, or Shelf Abutment

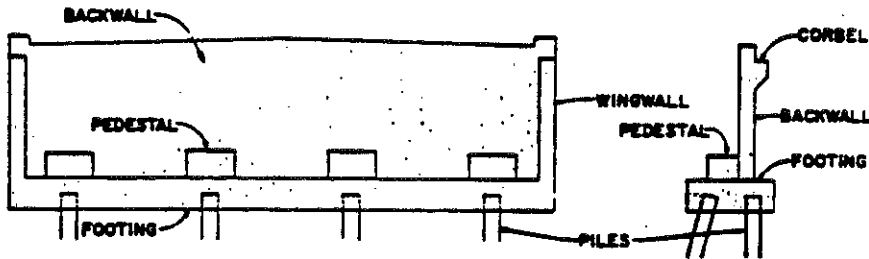

SILL TYPE ABUTMENT ON PILES

Spill-Thru or Open Abutment

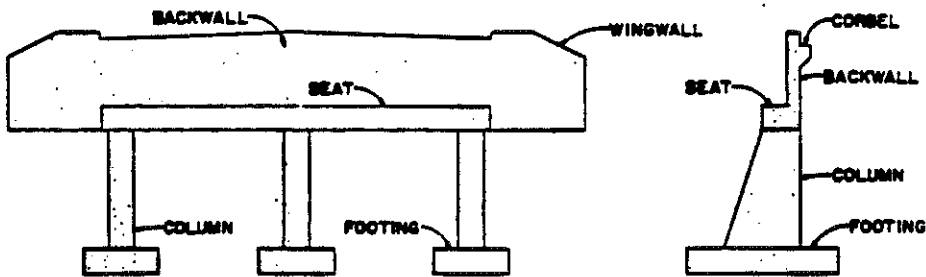

SPILL-THRU TYPE ABUTMENT ON COLUMNS & FOOTINGS

Figure 49. Typical Abutments.

The floating fender or camel system consists of horizontal and/or vertical timber members bolted to the wharf structure. The timber pile system employs piles driven along a wharf-face bottom. Pile tops may or may not be supported laterally. Steel and concrete piles also may be used.

Deterioration and/or damage to fender systems may result from collision with debris or vehicles. Natural deterioration may result from timber destruction that may take the form of decay from fungi, attack by vermin, and weathering. Steel deterioration may take the form of corrosion, while concrete deterioration will likely involve accelerated weathering because of the constant contact with water and the environment. If moisture reaches reinforcing steel, additional problems associated with expansion of the reinforcing steel and related cracking of the concrete can be anticipated.

#### **4.2.5 Piers and Bents**

Bridge piers and bents support bridge spans with minimum obstruction to the flow of traffic or water. The forces or loads acting on a pier or bent include the weight of the two spans plus the live loads and wind loads -- which includes not only the wind on the pier or bent, but also the wind on the superstructure and any live (moving) loads thereon. Also included are traction loads, i.e., the forces produced by live loads such as the braking of a truck; impact forces -- collision with vehicles or boats, water debris, and ice. Pressure of water flow (current), ice (also ice jams), waves breaking on pier or bent; buoyancy of the water acting on the pier; weight of pier or bent alone; as well as the movement of bridge spans as they expand and contract are forces acting upon a pier or bent. Malfunctioning bearings may cause longitudinal forces on piers and bents.

Many of the forces listed above are accounted for in the design process. Other forces such as impact forces may or may not be. The natural deterioration of materials may alter the ability of the structure to accommodate and distribute loadings. Damage associated with flooding (scour, accumulation of debris, etc) also may alter the ability of the substructure to transfer loads from the superstructure to the foundation.

Problems with piers or bents typically are associated with foundation failures or with failures of materials. Foundation failures may result from differential settlement, scour, inability of the soil or foundation to support the applied loads, excessive bearing pressures, saturation of the foundation soils, and seepage of water under and around the foundation materials. Deterioration of concrete, steel, and timber has been discussed earlier.

#### **4.2.6 Caps**

Caps form the top of the substructure. A pier or bent cap functions to transfer loads properly from the bridge superstructure through the substructure to the foundation-supporting materials. Caps for piers or bents may be constructed of concrete, steel, or timber. Concrete caps generally will be reinforced with steel and typically are used with concrete or steel piers or piles. Timber caps typically are used with timber

piles but also may be used with concrete and steel piles. Steel caps are the least used. Steel caps also function as a special type of floor beam.

Concrete caps may crack and spall in areas around bearing points. These conditions may be the result of poor design, construction errors, or overloading. In these areas, cracking may be due to penetration of moisture and the resulting corrosion of the reinforcing steel, causing expansion and accelerated deterioration of the concrete. Timber caps may be crushed in the areas around the bearing points. The crushing may be the result of improper design or construction or the result of overloads. Deterioration of timber because of decay, vermin damage, or other deterioration also may result in crushing at the bearing areas. Corrosion of steel caps is also a problem as with other steel members.

#### **4.2.7 Piling**

Since piles are buried in the soil and cannot readily be inspected, they seldom receive the necessary attention. Footer pedestal piles can be seen, but only in cases of scour can pier piles be seen. Usually, if detected early, deterioration or damage can be corrected.

Marine borers are a problem for timber piles in salt water environments but usually are not a problem in fresh water environments. Decay in areas of bolt holes, splices, cuts, and scrape areas are more of a problem in fresh water environments.

Steel piling generally does not corrode rapidly in fresh water. Salt water provides a much more corrosive environment. Underwater corrosion also is apt to proceed more rapidly on the edges of flanges of "H" piles. Scour sometimes may increase the potential for corrosion because of abrasion of the steel surface that exposes the inner portion of the pile to corrosion.

Abrasion or scour of underwater concrete structures sometimes results from the action of water flow and debris and sediment in the water. Waves and/or impact damage can cause bending of piles and localized cracking. Such cracking permits the penetration of water, resulting in the corrosion of the reinforcing steel and in spalling. Sea water especially is damaging because of accelerated corrosion of the reinforcing steel and also because of the chemical decomposition of the concrete. Freeze/thaw cycles also tend to promote the deterioration of concrete. The quality of concrete and construction procedures are always a factor relating to the performance of concrete.

### **4.3 BRIDGE DECKS**

The conditions of bridge decks and the approaches are probably the things most noticed by motorists. If the ride over the bridge is rough or slippery when the deck is wet or iced over, the bridge official will probably hear about it. Even worse, a deck may "break through", causing vehicles much damage. He would certainly hear about those occurrences -- many times over.

When a bridge deck consists mainly of planking, the combined effect of moisture, loads, and weathering will cause splintering of the wood in the wheel paths. Additionally, termite attack is possible if

the bridge deck is not chemically protected. Also, when a soft wood is used for bridge deck planking, it must be thoroughly treated to prevent weathering. It is possible to put a 3/4- to 1-inch thick asphalt wearing surface on the deck to minimize or delay deterioration of a wooden deck and also reduce slipperiness in wet weather. A yearly walk-over inspection, using a screw driver to "probe" the deck, will reveal any major deterioration problems.

Metal-grate decks are subject to corrosion and fracture of welds or rivets that connect the grates. Corroded sections may lose too much section and break when heavily loaded. Sections of the grate may also break due to fatigue when the bridges are loaded repeatedly by heavy vehicles. These conditions will usually become evident before the damage is too critical.

Most bridge decks are constructed of steel-reinforced concrete. Traffic can cause wearing in the wheel paths, leading eventually to problems with water ponding and in turn slipperiness due to hydroplaning or ice. Also, concrete bridges are usually salted heavily in winter to prevent ice from forming. Eventually, some salt penetrates into the concrete, weakening the concrete. Even worse, the salt attacks the reinforcing steel and causes it to rust. The rust expands and causes the concrete to break off or spall (Figure 32).

A minimum of 2 inches cover for reinforcement is recommended, as insufficient cover could shorten the service life of a bridge. Also, experience has indicated that excessive vibration or flexure of the superstructure may result in accelerated deterioration of bridge decks.

If the spall is removed, it will expose a portion of the corroded reinforcing steel. The denser the concrete, and the greater the thickness of concrete over the reinforcing steel, the more resistant the bridge deck will be to spalling. The amount of spalling can be determined both visually and by sounding with a steel rod (tapping the bridge deck and listening for a hollow sound).

Concrete may contain expansive aggregate or shales that break up over time due to the weathering process. This will cause concrete to have a pock-marked appearance, but will be harmless unless a large amount of poor aggregate is present.

Poor quality concrete, which could be caused by a high water/cement ratio, incorrect air content, poor aggregates, or undesirable chemical reactions between the aggregates and other constituents of the concrete. Poor curing causes shrinkage cracks due to insufficient moisture for curing or the freezing of fresh concrete.

Some concrete decks have been overlain with asphaltic concrete to maintain grade when the rest of the road is overlain. Asphaltic wearing surfaces also may hasten the degeneration of the underlying bridge deck unless there is an effective waterproofing membrane between the concrete deck and the bituminous wearing surface. The asphaltic concrete may rut in the wheel paths with time. Excessive thicknesses of overlay should not be placed on the deck, thereby increasing the dead load and decreasing the live load-carrying capacity of the bridge.

#### 4.4 BRIDGE SUPERSTRUCTURES

Superstructures are subject to problems as they age. The problems are due to weathering, applications of deicing salts, and traffic loads. The superstructure may be affected by the performance of deck, approaches, and substructure. Various bridge designs and bridge materials will deteriorate differently with age. Therefore, it is best to look at each general type of bridge to determine what problems may be expected.

Steel and wrought-iron truss bridges are usually over 30 years old. The biggest problems with these bridges are corrosion damage, fretting, and loose members and connections.

Corrosion usually leads to pitting in the surface of the metal or the unusual thinning (called loss of section) of the member over its length. Corrosion damage is more likely on bridges that have not been suitably painted previously. More severe corrosion is found on the lower members of drive-through trusses from about head height (standing on the deck) to below the roadway. Often, it is necessary to remove the loose scaly rust on the surface of the member to determine the extent of damage. This can be done by sandblasting or by chipping and wire brushing. Severe loss of section can lead to sagging, especially of floor beams.

Corrosion also may attack riveted and pinned connections. Since the rust expands, it exerts strong forces. If several plates riveted together have rust between them, the expansion due to rust may literally break the rivets. Rust may cause pinned connections to weaken due to loss of section of the pins. Also, it may freeze expansion devices, prohibiting movement. This induces additional stresses in the trusses.

Pinned connections in many trusses are points of long-term deterioration. Eyebars that contact pins may gouge into them and eventually cut through the pin. This is caused by repeated small movements between mating surfaces called fretting. Close inspection is required to detect this type of deterioration (Figure 50).

Repeated heavy loads may loosen joints and connections. This may be detected by listening for banging noises as loads pass over the bridge. Loose diagonal tension members may readily sway sideways. Fretting marks around rivet heads at connections are signs of looseness created by previous heavy loads and wear in the rivet shanks.

Vehicular collisions may damage overhead bracing. Damage to interior bracing is usually not as critical as damage to the portal or end posts. Damage to end posts may be critical, and any such damage should be inspected by a professional engineer since it may warrant closure or posting of the bridge prior to repair. Bullet holes are especially dangerous in tension members. Those should also be inspected by an engineer to determine whether damage is critical.

Cracking may be present in metal superstructure tension members. It may be expected around welded, riveted, or bolted connections; at eyebars; or along tension members. Cracks also may be expected at places where welds have been carelessly placed.

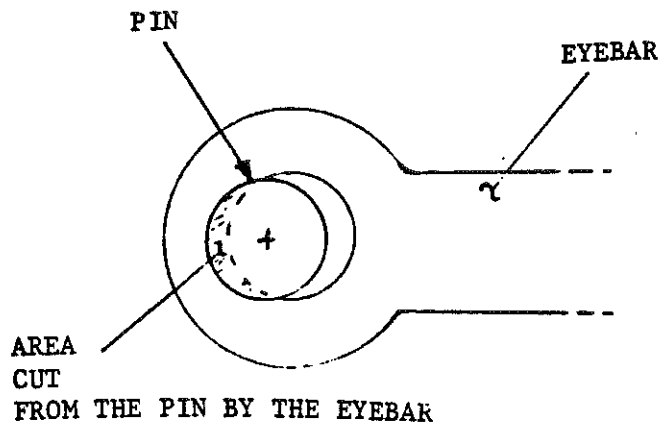

Figure 50. Eyebar Head Cutting into Pin.

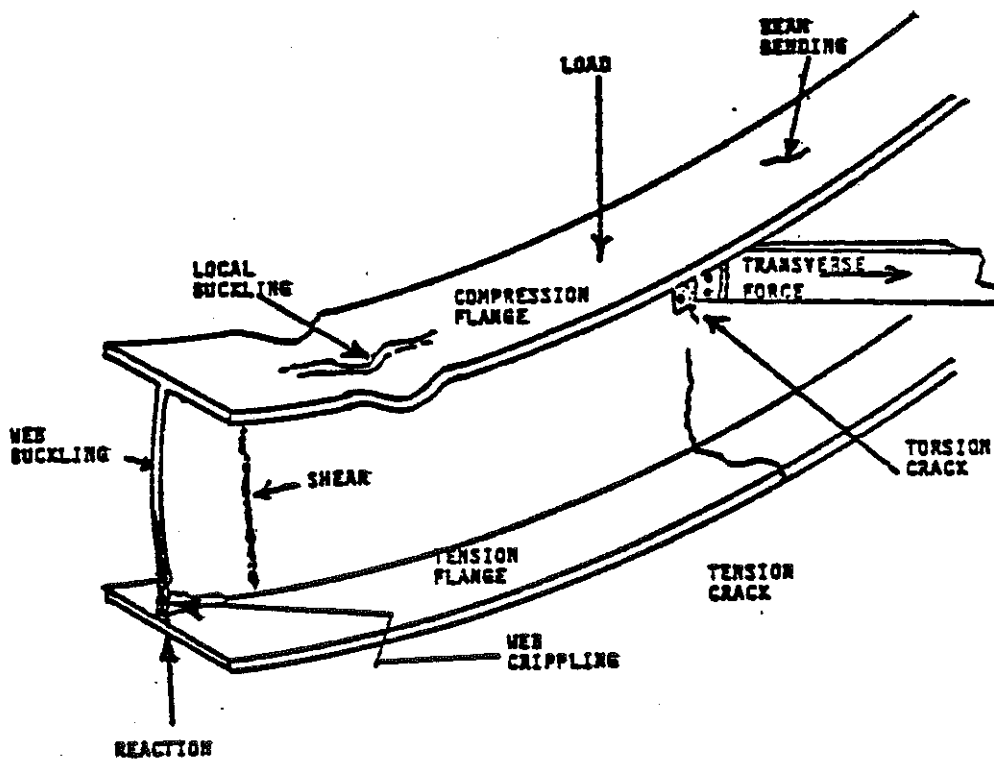

Figure 51. Typical Deterioration of Beams and Girders.

Riveted and welded steel girder bridges are subject to corrosion and overload damage (Figure 51). Corrosion is most common near expansion joints where water can spill onto girder ends. Water also may pond on the lower flanges increasing corrosive damage. Usually, the outer girders will corrode more than those under the bridge.

Buckling at the web is a sign of overload and indicates a weakened structural member. Occasionally, a stringer will sag to an extent that it will not be carrying its share of the load. In those cases, a gap will be visible between the upper flange of the girder and the deck.

Rivet corrosion problems similar to those in trusses can be expected in built-up girders. Cracking can occur in the lower portions of simple-span girders (riveted and welded). In riveted bridges, cracks can be expected to run from the rivet holes and travel up the web. In welded girders, cracks normally run from welds, such as butt welds or cover-plate end welds. Again, the cracks will tend to run up the girders.

Overpass bridge girders sometimes are hit by oversized vehicles. The girders should be inspected to see if any cracking has occurred. The girders can be flame-straightened, but experienced personnel should be employed to do that.

Reinforced concrete deck girder and prestressed concrete beams (box and I girder) have very few service problems. Problems that do exist are related to salt penetration of the box girders and corrosion of the reinforcing steel. This is particularly true when the steel has an insufficient concrete cover. In those cases, spalled and cracked concrete and rust stains will be evident. The cracked concrete may be removed to expose the corroded underlying steel reinforcement. Badly weathered or old concrete will crumble where the exposed aggregate can literally be plucked loose. Poor concrete containing excessive expansive aggregate will fail by weathering and give the concrete the previously mentioned pock-marked appearance.

Timber bridges may be subject to insect attack and weathering. Insect attack (termites) usually will leave a very crumbled wood. Also, that is usually a sign of untreated wood. Poorly seasoned or weathered wood may split or sag in time. Long-term presence of water also will cause damaging rot, which will leave crumbling wood. Usually, those conditions will be worse on exterior beams or at stringer ends.

#### **4.5 CULVERT MAINTENANCE**

The basis for a maintenance program for culverts (as well as for bridges, pavements, etc.) is related to the quality of inspection and evaluation procedures. Specific areas of culvert inspection include the following:

1. scour at the inlet;
2. scour at the outlet;
3. partially collapsed metal culvert;
4. piping;
5. sediment deposition in the culvert;
6. abrasion;
7. corrosion of metal culverts;



8. leakage at joints;
9. deterioration of concrete materials;
10. damaged or deteriorated headwalls, wing walls, and endwalls;
- and
11. damaged culvert ends.

Scour, or erosion, at the inlet occurs because of turbulence and poor protection of the embankment. Rough surfaces create turbulence, which in turn may contribute to scour. Partial blockages also may increase water velocities and contribute to scour. Concrete endwalls, wing walls, and curtain walls can be used to protect the ends of a culvert from erosion and scour. Bags of concrete, large boulders, and gabions may be used to supplement or in lieu of the concrete walls.

Scour at the outlet results when the high velocity of flow is confined to a lesser width and greater depth than the natural channel. Endwalls, cutoff walls, and aprons of concrete or rip rap typically provide adequate protection against scour. If the velocity is significantly greater than the velocity in downstream channel, stilling basins or energy dissipators are necessary.

A partially collapsed metal culvert may be detected by settlement of the overlying roadway. In such situations, corrective action is essential. Temporary repairs include shoring and bracing similar to that used in mines. Since the bracing restricts flow and increases the potential for clogging, it must be replaced with a permanent repair. Settlement or depressions in the roadway must be repaired. In those situations where there is a partially collapsed culvert but no settlement or depression of the roadway surface, immediate repairs may not be necessary. However, the situation should be monitored. Replacement is the permanent repair strategy.

Piping results when seepage along the exterior of the culvert barrel removes backfill material and forms cavities under and around the outside of the culvert barrel. If ponding or high velocity water flow occurs, erosion inside the embankment may result in a failure of the culvert and/or the embankment. Piping also may occur through open joints in the culvert barrel. Procedures for control of piping include installation of headwalls, curtain walls, bulkheads, and/or sheet piling at the inlet end of the culvert; installation of anti-seep collars; and/or grouting to fill voids around and under culvert barrels.

Sediment will collect in the bottom of the culvert to the normal channel grade when a culvert is set too low. Cleaning is only a temporary repair measure unless the sediment is caused by a blockage of the stream downstream. Otherwise, relaying the culvert to the channel grade is the only permanent remedy.

Abrasion is the erosion or wearing away of culvert materials by water and debris carried through the culvert. Abrasion is most common in those areas where high velocities of flow carry rocks and other large debris through the culvert. Concrete culverts should be constructed using high durability mixes to control abrasion and freeze-thaw damage. Metal culverts should have protective coatings to help slow the rate of abrasion. Paved inserts on metal culverts have been used with some degree of success. Excessive abrasion can result in the need to replace the culvert if structural integrity is significantly damaged. Therefore, periodic inspection is critical.

Metal culverts are susceptible to corrosion, which may be caused and aggravated by the acidic or alkaline conditions of soil and water. Corrosion may be accelerated in those areas where protective coatings have been damaged or worn away. Metal culverts can be partially protected from corrosion by coating with bituminous materials. Asbestos sometimes is used in combination with bituminous materials as a corrosion resistant coating. Steel may be galvanized to provide protection from corrosion. Thermoplastic coating also has been used as a protective coating for some metal culverts. Replacement of the culvert is the final alternative when corrosion deterioration is excessive.

Leakage at joints in the culvert structure may result from settlement of the foundation, poor or damaged seals, and/or excessive seepage. The resulting leakage can cause an undermining of the foundation for the culvert. Leakage at joints often can be eliminated during construction with proper compaction of the foundation, properly constructed and sealed joints, and control of seepage. Flexible seals should be used in lieu of mortar wherever possible and practical. Leakage resulting from settlement should be repaired by relaying to the proper alignment and grade. Leakages in concrete culverts may be repaired by grouting with mortar or pasting with epoxy or bituminous materials. Leakage at joints of metal culverts may be repaired by excavation of the embankment and replacement of the band. Occasionally, grouting of voids between sections of metal pipe is successful if the flow of water can be diverted to allow curing of the grout.

Concrete culverts are subject to cracking, spalling, and abrasion. Surface or hairline cracks, caused by drying and shrinkage, are usually not detrimental but should be observed for deterioration and change. Longitudinal cracks having a width less than 0.01-inch typically result because of the flexing or bending of the reinforced concrete structure. Cracks wider than 0.01-inch may be flexural cracks or also may result from improper design or construction. Cracks less than 0.01-inch wide present no problem and require no maintenance. Cracks having widths between 0.01 and 0.1 inch are not detrimental structurally, but should be sealed to control potential corrosion of reinforcing steel (especially in a corrosive environment). Cracks greater than 0.1-inch are not necessarily detrimental structurally, but should always be sealed. Spalling of the concrete cover over reinforcement should be patched using grout or epoxy.

Headwalls, wing walls, and endwalls anchor the culvert against hydraulic and buoyant forces, improve hydraulic capacity, and resist scour of the embankment. These structures are subject to settlement, undermining, or tipping. Concrete-filled bags or stone rip rap may be used to prevent or control scour or to compensate for settlement. Extending footings below the scour line or installing aprons also may be used to control scour. Extended footings or the installation of sheet piling may be used to counter tipping. If damage is extensive, removal and replacement is often the only alternative.

Metal culverts often are constructed without headwalls, wing walls, or endwalls. As such, they often are damaged by high-velocity water flow and the impact of debris. Damaged culvert ends may be removed by excavation of the embankment, cutting off the length of the damaged culvert end, and replacement of a new culvert end. The new culvert end should be secured to the old culvert by collars or

culvert bands. Proper attention should be given to backfilling and compaction of foundation and embankment materials.

## 5.0 PREVENTATIVE MAINTENANCE

If the word preventative is added to the word maintenance, one obtains a good means of balancing bridge needs with a limited budget. Often in bridge maintenance, the little things count. The willingness to clean clogged scuppers or the drain line on a bridge deck, spot painting of rusted steel, repairing cracked or spalled concrete, and cleaning trash from a stream may be small jobs, but by doing those, one may prevent problems that could grow in the future.

It may be repetitive, but the local bridge official should know the condition of his bridges to properly plan preventative maintenance. Besides being cheaper than major repairs, preventative maintenance usually can be done by local forces. Also, since most of the jobs are small, they may be scheduled around other tasks. Some work can be done in the fall or even the winter, keeping a crew busy throughout the year.

To plan preventative maintenance, the bridge official should look at the KYDOH SI&A reports, bridge inspection list, or better yet, visit most of the bridges. They should be examined closely for the minor problems suitable for preventative maintenance. The work can be done either by fixing all the small faults, one bridge at a time, or by going out and doing the same repair on a number of bridges.

The bridge official always should give complete instructions as to how he wants the work done. If possible, he should take several "Polaroid" photos to show what is wrong with the bridge. Also, he should have someone inspect the job, or better yet, be there himself during a portion of the work. The bridge official should take interest in the quality of work his crew performs. He should maintain records of work accomplished and check to see how the repairs are performing. If a certain fix is not performing satisfactorily, either an inappropriate method of repair is being used or the quality of work is inadequate. By following-up on repairs, techniques that work best are determined.

## 6.0 MAJOR REPAIRS

Even when proper inspections and preventative maintenance are performed, occasionally a bridge will require major repairs or modifications. A bridge may need to be widened, strengthened, or painted. Perhaps a stream problem or slope failure will need to be repaired. A bridge deck may need to be overlaid or replaced. A vehicle may have hit the bridge or maybe a concrete deck is crumbling. Whatever the problem, it will require considerable attention. A consulting engineer may need to be employed and estimates from contractors will be required. Unless a large experienced and well equipped crew is available, many of those repairs may be beyond in-house capabilities.

Bridges need many different major repairs. It is impossible to explain every major fix. Therefore, a brief review of some possible major repairs will be presented.

### 6.1 PROTECTION AGAINST EROSION

Protective measures may be classified by the materials of which they are constructed, the general shape of the protective device, or their function or application. Classifications include armor, retard, jetty, groin, bulkhead, baffle, and vegetation.

The armor type of protection requires the artificial surfacing of bed, banks, shores, or embankments to resist erosion or scour. Armor, the most popular type of protective device, provides protection directly in contact with the embankment. Also, the protective device may be built within the normal right of way, and there is access for inspection directly from the roadway. Armor protective devices may include sacked concrete, asphalt slope paving, wire mattresses, rip rap, and wire mesh netting.

Retards are a type of embankment protection device designed to induce silting or trap floating debris. Retards are permeable structures constructed parallel to the toe of the slope. Retards function primarily to slow the velocity, reversing the trend of erosion by deposition and replacement of lost material. Common types of retards are steel tetrahedrons, concrete tetrahedrons, timber jacks, steel jacks, single or double lines of fences, a line or lines of timber pilings, or pile bents. Large debris should be removed from retards to prevent damage to the retard protective devices.

A jetty is a type of artificial wall built out into the water from the bank to restrain currents and protect the ends of piers and abutments from severe scour. Impermeable jetties (such as log types) serve only to deflect the stream flow. Permeable jetties permit some water to pass through, but also serve to deflect a portion of the stream flow. Jetties should be securely anchored. Common materials for construction of jetties range from timber-braced piling to old automobile bodies.

A groin is a barrier oblique to the primary motion of the water. Groin-type shore protection batteries may be constructed of steel, concrete, or timber sheet piling with the internal cells or cribs constructed of steel or concrete and filled with stone. Lost fill material should be replaced.

A bulkhead or retaining wall is a steep or vertical structure that supports the natural or artificial embankment material. Although usually expensive, bulkheads may be justified economically for certain special conditions. Bulkheads may consist of the following materials:

1. timber or timber piling,
2. concrete wall,
3. masonry wall,
4. timber sheet piling,
5. steel sheet piling,
6. concrete cribbing,
7. concrete sheet piling, and
8. timber or log cribbing.

A baffle is a pier, vane, sill, fence, wall, or mound built on the bed of a stream to parry, deflect, check, or disturb the flow or to float on the surface to dampen wave action. Fence type baffles are the most frequently used.

The cheapest form of slope or bank protection is an effective cover of vegetation. Vegetation may take the form of grass or bushes or trees. A stand of willow trees is one of the most effective types of vegetation cover.

## **6.2 BRIDGE DECKS**

### ***6.2.1 Evaluation of Bridge Deck Deterioration***

Evaluation of a bridge deck should include visual surveys, delamination detection, chloride analyses, cover measurements, electrical potential measurements for detection of corrosion, as well as core samples.

A visual survey is used to locate, describe, and quantify observable distresses and deterioration on both the top and bottom of the deck. Cracking, spalling, scaling, full-depth moisture penetration, and deck patching are documented by visual surveys.

Delamination detection surveys provide information on subsurface bridge deck conditions. Delaminations are detected by sounding with rods to locate hollow sounding areas. An automated delamination detection device, "Delamtect", has been used with some success. Sounding also may be used to detect inadequate bonding of concrete patches.

A chloride analysis provides a quantitative measure of chloride ion contamination at various depths in the concrete deck. Samples are collected by coring and must be evaluated in the laboratory. Between 1.3 and 2.0 pounds of chloride per cubic yard of concrete is necessary to initiate corrosion.

Cover measurement is simply a determination of the depth of steel reinforcement below the surface of the deck. An instrument called an "r-meter" or "pachometer" is used to determine this depth of embedment. The depth of steel compared with the depth of chloride penetration may be used to estimate the potential for corrosion.

Evaluation of bridge decks also includes electrical potential measurements for detection of corrosion. Corrosion of reinforcement steel actually is caused by an electric current flowing from the rebar at one point (anode) into the bar at another point (cathode). This flow in a galvanometer gives a negative reading. During active corrosion, there is an electrical difference (potential) between the anode and cathode. Active corrosion typically is associated with a potential difference of -0.35 volts. A potential reading less than -0.20 volts usually is associated with a state of no corrosion. Areas of active corrosion can be determined from potential readings on a bridge deck. Active corrosion areas can be taken into account when considering repair strategies and needs.

Core samples may be used to determine the strength of the concrete and to visually study its condition. Because of its destructive nature, coring should be used sparingly.

### **6.2.2 Rehabilitation/Repair Strategies**

In 1976, the Federal Highway Administration issued guidelines for categorizing the condition of existing bridge decks. The levels of deterioration are as follows:

1. Category 1 -- Extensive Active Corrosion
  - a. 5% or more of the deck visibly spalled and
  - b. 40% or more of the deck having deteriorated and/or contaminated concrete or active rebar corrosion indicated by a summation of nonduplicating areas consisting of the following: (1) spalls, (2) delaminations, (3) electrical potentials over -0.35 volts (Copper/Copper Sulfate (CSE) Half-Cell Method), and (4) chloride content greater than 2 pounds of chloride per cubic yard of concrete as determined by 10 random samples of the deck area excluding the areas previously determined as spalls, delaminations, and potentials over -0.35 volts.
2. Category 2 -- Moderate Active Corrosion
  - a. Less than 5% of the deck visibly spalled and
  - b. 5% to 40% of the deck area having deteriorated and/or contaminated concrete or active rebar corrosion as indicated of the summation of nonduplicating areas consisting of those defects noted above.
3. Category 3 -- Slight to No Active Corrosion
  - a. No visible spalls and
  - b. Less than 5% of the deck area having deteriorated and/or contaminated concrete or active rebar corrosion as indicated by a summation of nonduplicating areas consisting of those defects noted above.

It is recommended that all concrete showing deterioration in the form of spalling, chloride contamination, or active corrosion be removed. Complete deck replacement is recommended if more than 5 percent of the deck area has spalling, chloride contamination, or active corrosion. The percentage of

patched surface area may be increased if it is desired to extend the service life of the bridge by 10 to 15 years. The economics of these strategies should be investigated. The labor intensive nature of concrete removal and patching often is less expensive than total replacement. Materials, equipment, and skills required for bridge deck repair and replacement activities may be extensive, dependent upon specific repair and rehabilitation needs.

### **6.2.3 Rehabilitation Procedures**

Procedures for rehabilitation are patching, epoxy injection, use of waterproof membranes, use of overlays, cathodic protection, or redecking and widening.

**6.2.3.1 Patching.** Patching includes removing concrete in areas having sufficient chloride contents to sustain corrosion to a depth of 1/4 inch plus the maximum aggregate size below the bottom of the top mat of reinforcing steel. Areas to be patched can be defined in the deck by sounding. Soundings may be supplemented by potential readings and chloride samples. Boundaries of the areas to be patched should be sawed to a depth of at least 1 inch and the concrete removed. Reinforcing steel should be cleaned.

Deck patching materials are variable. Conventional portland cement concrete often is used, but is slow setting and requires considerable curing time. Concretes containing setting accelerators, fast setting cements, polymer compounds, and polymer concrete (polymer and concrete) have been used in many areas. Bonding compounds also vary with repair materials. Typically a grout is brushed into the clean sound concrete surface of the underlying concrete to form a sound bond between old and new. Some polymer-modified concretes do not require a bonding agent. A coating of epoxy also is sometimes used as a bonding agent. Patching a deck may be followed by installation of a protective coating or membrane over the total deck surface.

**6.2.3.2 Epoxy Injection.** Epoxy injection is an alternate to removing and patching a delaminated area in bridge decks. The procedure is not permanent, but may be used to extend the service life of a deck. The injection procedure involves drilling holes through the delaminated area between the reinforcing bars to a depth of 2 or 3 inches below the delamination. An epoxy capable of bonding wet surfaces is injected under pressure into the holes. The pumping system should have the capability of combining the two components at the injection nozzle. Polymers other than epoxies have been used with mixed success. Repairs using epoxy injection systems require more expertise than conventional patching.

**6.2.3.3 Waterproof Membranes.** Waterproof membranes and bituminous concrete wearing surfaces are used routinely on new construction by some agencies. The use of coated reinforcement steel for new construction has reduced the use of membranes. However, the use of membranes for rehabilitation continues.



Early membranes were constructed in layers of bituminous material and reinforcement such as fiberglass cloth. More recently, membranes using epoxy resin systems in combination with bituminous wearing courses have been used. Preformed membranes of sealer and reinforcement also have been developed. Preformed membranes include both hot- and coldapplied systems. Most membranes require a 1-1/2-inch to 2-inch wearing surface to provide durability under traffic. Analyses should be conducted to assure the structure can carry the additional deadload. Slippage between the deck, the membrane, and the wearing course also is a concern. Therefore, membrane systems typically are limited to use on grades less than four percent.

**6.2.3.4 Overlays.** Overlays may be an effective and permanent alternative to the use of membrane and wearing surface treatments. Overlays typically are more expensive. Materials that have been used successfully for overlays include portland cement concrete, polymer-modified concrete, internally sealed concrete, and polymer concrete.

Portland cement concrete overlays of about 2 inches have been used successfully. A low-slump concrete having a water/cement ratio of about 0.32 and a slump of 1 inch or less typically is specified to provide impermeability and minimize shrinkage.

A polymer-modified concrete is a portland cement concrete with a polymer added during mixing. Polymer latex modified concrete overlays provide superior resistance to the penetration of chloride ions but generally are more expensive.

Internally sealed concrete is a form of polymer-modified concrete that contains small wax spheres added during mixing and melted after the concrete has cured. A temperature of 365 F is required to melt the wax to a depth of 2 inches, which is the minimum thickness of overlay. Therefore an external heater is required. Heaters may be in the form of infrared or electric blanket systems. Internally sealed concrete overlays have shown promise, but are still considered experimental.

Polymer concretes consist of fine aggregate and polymer. The material is placed in thin layers of approximately 1/8 inch, with the polymer placed first and the aggregate material broadcast onto the deck. Each layer is rolled using a pneumatic-tired roller. Typically, four layers are used. The final overlay thickness is about 3/8 to 1/2 inch and apparently is impervious. Although still considered experimental, polymer overlays have the apparent advantage of reduced weight and fast setting quality that reduces the length of time the structure or a lane must be closed.

**6.2.3.5 Cathodic Protection.** Corrosion requires an anode, a point on the reinforcing steel where ions are released, and a cathode, another point on the steel where ions are received. Cathodic protection is the application of direct current such that the reinforcing steel becomes cathodic relative to anodes located on the deck. An external power source is impressed on the circuit between the anodes and the top reinforcing mat. The anodes are placed in the conductive bituminous layer on the deck surface and typically are high silicon-iron or graphite. The conductive layer is typically a mixture of coke aggregate, asphalt, stone, and sand and is required to minimize the number of anodes required to protect the deck.

Disadvantages of cathodic protection include the need for periodic adjustment, a continuing (but minimal) power requirement, possible disbonding of the overlay, and the need for expertise in design and construction. The bituminous overlay should be a minimum of 3 inches, typically 1-1/2 inches of the aggregate-coke conductive layer and 1-1/2 inches of bituminous wearing course. The conductive layer does not have the qualities of a wearing surface.

The most significant advantage of cathodic protection lies in its ability to halt the progress of corrosion without the removal of chloride contaminated concrete. Epoxy and polymer concrete treatments are not recommended if cathodic protection is anticipated because of the insulating effect on reinforcing steel.

**6.2.3.6 Redecking and Widening.** Replacement of the entire deck may be necessary in cases of severe deterioration. In some situations, this may be more economical than removal of all concrete to a level below the top reinforcing mat.

Durability is a prime consideration in the repair of a deck. Durability generally is attained through the placement of concrete with low absorption and is not associated directly with the commonly measured strength of the concrete. Unpublished research indicates absorption should be less than 4.5 percent.

Critical factors affecting the performance of a bridge deck include

a. **Cover for Reinforcing Steel**

At least 2 inches of clear cover over reinforcing steel is recommended.

b. **Water/Cement Ratio**

The water/cement ratio must be low. A value of 0.40 (0.45 with 2-1/2 inches minimum cover) has been recommended, and lower values are used for low-slump and high-density mixes.

c. **Air Entrainment**

The proper degree of air entrainment is required.

d. **Consolidation**

Proper consolidation is essential.

e. **Curing**

The concrete must be given proper and timely curing.

The performance of a bridge deck may be enhanced by the use of protective features. Waterproofing membranes is one protective feature that has been used successfully. Probably the most popular protective system currently used is the application of epoxy-coated reinforcing steel in the top mat. Bridge decks may be constructed in two layers with the lower portion of the deck constructed with good quality concrete having the necessary strength to meet structural requirements while the upper portion of the deck is constructed of concrete having low permeability to slow the rate of penetration of chloride ions.

Widening of a deck often accompanies deck replacement. Construction typically occurs by lane. A concern during construction relates to the effects of induced vibration caused by the traffic in adjacent

lanes. Generally, it has been concluded that these concerns are unfounded for normal construction activities. Widening should be attached to the existing structure. Moment transfer should be provided at the joint between new and old portions of the deck. Lapped reinforcing bars are preferable to dowel bars and should be tied securely or welded. Dowels and reinforcing steel should be straight. A concrete keyway is not necessary. A closure pour is recommended to achieve a smooth surface when an overlay will not be placed on the existing deck. Where the fascia beam of the existing structure differs from other beams in either section or camber, it should be removed and used as the fascia beam in the new deck.

## **6.3 SUPERSTRUCTURE STEEL BRIDGE COMPONENTS**

### ***6.3.1 Painting***

The most common maintenance necessary on metal bridges is painting. The need for repainting can be based on the extent of corrosion on the structure. If preventative maintenance spot painting is not utilized, a steel bridge should be repainted about every 10 years or when about 20 percent of the surface shows visible rust. Sometimes a few truss members or girders may be heavily corroded and show visible signs of loss of section. Spot-painting should be considered in those cases.

The easiest way to remove loose rust for small spot painting jobs is by wire brushing using a powered handtool. Small, cheap air-grit blast units are available and can be operated from an air compressor for cleaning of intermediate-sized areas.

A bridge needing repainting may have to be closed to traffic or shielded to keep paint off passing cars. Painting should never be done in the cold, in the rain, during high winds, or during times of extreme heat. For complete repainting jobs, the steel or wrought iron should be cleaned to a near-white finish using wet-abrasive blasting. The water used should contain an inhibitor to prevent flash-rusting. The blast-cleaning operation should not progress so far beyond the painting that the blast-cleaned surface cannot be painted within 24 hours.

The paint job should be tested with wet- or dry-film gages to determine that the paint contractor is providing the specified job. Both flat, vertical, and overhead surfaces should be tested to insure that the proper film thickness is being deposited. Also, make sure the base coat has dried to touch before the next coat is applied. No more than 5 mils (wet) of paint per coat should be deposited.

There are many types of paints used on bridges. At this time, it is recommended to use the KYDOH specification for inorganic zinc primer with vinyl topcoats.

### ***6.3.2 Damage To Steel Bridge Members***

Bridge members that are badly corroded may have excessive loss of section. Many times new metal may be added by welding or bolting (Figure 52). However, all rust should be removed before the repairs are made.

**Cut Out Corroded Area  
and Weld New Steel Plate  
or WT Sections Along Dashed Lines**

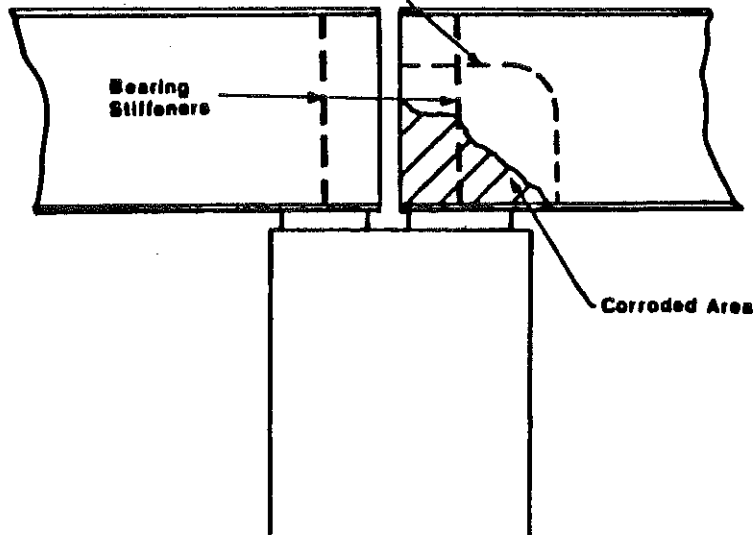

**Figure 52. Repair of Corroded Steel Beam Ends.**

Occasionally, one or two steel stringers will sag below the bridge deck. When this happens, the girder is usually not supporting its share of the load. Eventually, that may lead to punch-out cracking in the bridge deck. To prevent that, the girders can be brought into bearing by jamming wooden wedges between the upper flanges of the girders and the bridge deck.

If a truss eyebar is found to be cutting into a pin by fretting, it is wise to consider replacing both the eyebar and the pin. In some cases, the original eyebar head can be cut off and a new one welded to the shank. New hardened pins should be used to prevent future fretting damage.

Rivets occasionally break. They may be replaced with high-strength bolts. The rivet hole should be reamed prior to replacement with the bolt. Built-up plates of riveted structures are occasionally subject to corrosion between abutting plates. A coat of silicon sealant along the seam between the plates will minimize this problem.

Bridge damage due to vehicle impact may be critical, especially to the older through-truss bridges. Vehicle impacts to end posts, portals, and overhead sway bracing may lead to bridge collapse. If end posts are badly distorted, they may buckle compressively under future heavy loads. A truss bridge may collapse rapidly when an end post is hit or if it otherwise buckles. End portals and overhead sway bracing support the truss. Damage to them may cause the trusses to sway and collapse.

Vehicle impacts to overhead girder bridges may distort the flanges and webs and also cause cracking.

Bridge members badly distorted by impacts should be inspected promptly by a qualified engineer to determine if they need to be straightened, reinforced, or replaced.

Flame straightening of steel members can be accomplished by an experienced person using an oxyacetylene torch. That work should not be entrusted to one who does not have bridge-related flame-straightening experience. If done incorrectly, that procedure may lead to further ripple distortion in the member that cannot be removed.

Temporary reinforcing may be needed if some time will pass before permanent repairs can be made. Some buckled members can be stiffened by adding additional temporary or permanent material to support applied loads.

If a bridge member such as an end post is severely damaged, replacement may be necessary. Always consult with an engineer to determine the best method to support the applied dead loads while replacing a bridge member.

### ***6.3.3 Increasing the Load-Carrying Capacity of Bridges***

There are three practical ways of increasing the load-carrying capacity of bridges: 1) decrease the weight of the bridge (usually the deck), 2) strengthen the longitudinal load-bearing members (girders or trusses), or 3) place extra supports under the bridge at points intermediate to the abutments.

Concrete bridge decks add greatly to weight that the trusses and girders must support. If the concrete is replaced by a lighter deck system (i.e., steel grid, wood, or lightweight concrete), the dead load (weight of the bridge) is reduced and the load rating of the bridge may be increased. Of the lightweight alternatives, the steel grid is the most common (Figure 53). It probably has the best durability compared to the other types. Also, it probably would eliminate any need for increasing the strength of the deck support system. However, steel grid decks become slippery when wet and very slick when iced over. They should probably not be used in bridges located on curves.

The load capacity of simple span steel-girder bridges can be increased several ways. One way is to put cover plates on the bottom flanges of existing girders (Figure 54). Another method is to add king posts to the lower portion of the existing girders. A third possibility would be to insert extra stringers under the deck.

When adding cover plates, the bridge must be jacked to remove the dead load. Then, the cover plates are clamped onto the lower flange (and possibly the upper flange) and welded in place.

Installing king posts requires bolting end brackets to the lower flange of the beam. Then, the king post is clamped in the center of the span. Post-tensioning rods are attached to the brackets looping over the king post and are tensioned by tightening bolts anchored on the threaded post-tension rod ends.

Usually, it is difficult to strengthen trusses. Often, there are limits to the load-carrying capacities of joints of older bridges (which are often pinned or riveted). It is difficult to design around those major connections on a retrofit basis (cheaply). One interesting retrofit has been to insert a steel arch in the truss (Figure 55). This modification can be achieved for about 50 percent of the cost of a new bridge. Large increases in load carrying capacity have been achieved by that retrofit.

The addition of extra stringers will require modification to the abutment (and possibly pier pedestals). The ease of snaking extra stringers under a bridge may depend greatly on the access of a lift boom or other lift vehicle to the underside of the bridge.

Another way of strengthening bridges is to add intermediate supports between existing abutments and piers, as shown in Figure 56 for a simple girder bridge. In this case, extra longitudinal and deck support also is provided.

Sometimes, weak bridges can be kept in service at least for a short-term by placing one or more intermediate supports. Shoring may be achieved using cribbing, cross-stacked beams (Figure 57) or pile bents (Figure 58).

### **6.3.4 Major Repairs and Alterations of Bridge Components**

Jacking a superstructure often is required to affect repairs or modifications. This may damage the bridge if done incorrectly. A professional structural engineer should design or review the jacking procedure. In general, hydraulic jacks are used to raise the superstructure (Figure 59). Once the structure is jacked, blocking can be wedged between the bent and superstructure to carry the elevated load.

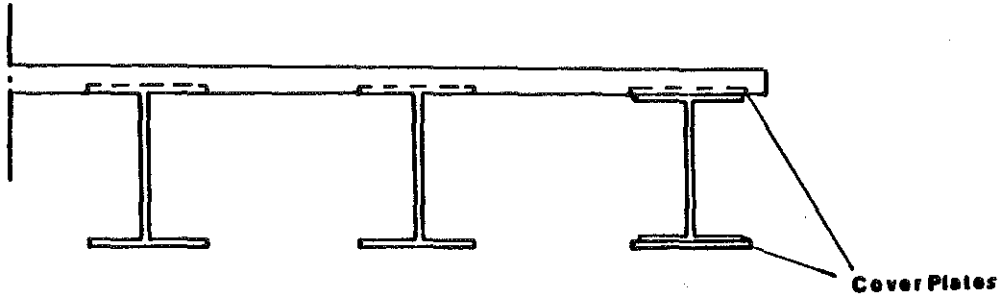

Figure 53. Cover Plates Added to Stringer.

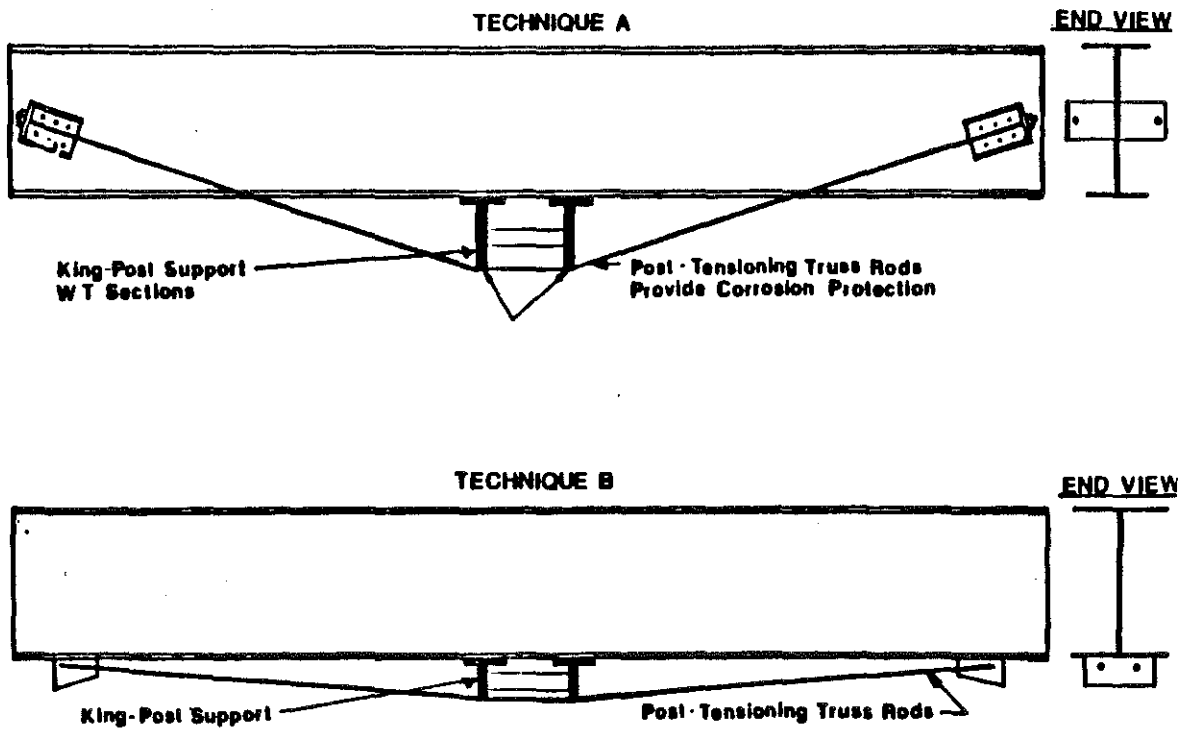

Figure 54. Side Elevation of King-Post Strengthened Beam.

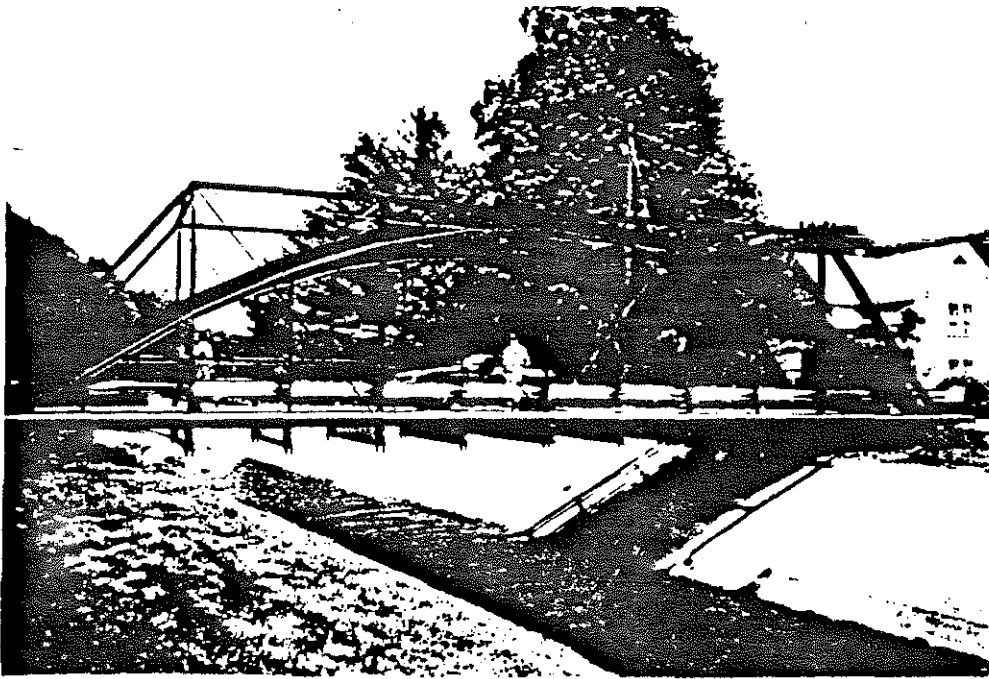

Figure 55. Arch Reinforcement of a Truss Bridge.



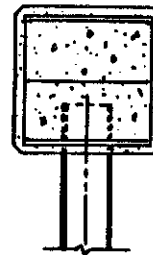
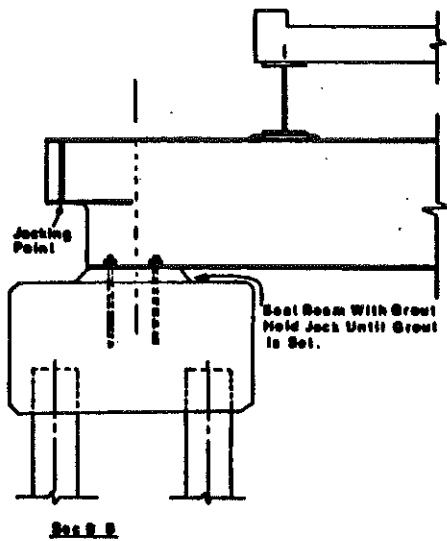
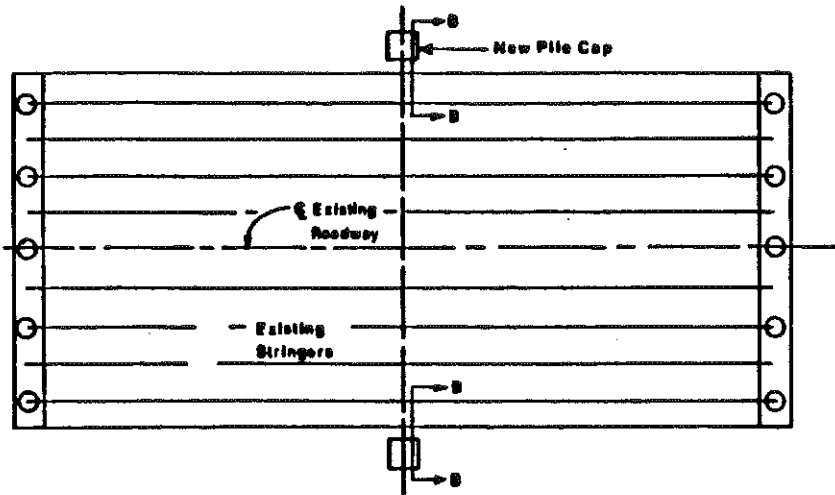

Figure 56. Addition of an Intermediate Support to Increase Structural Capacity.

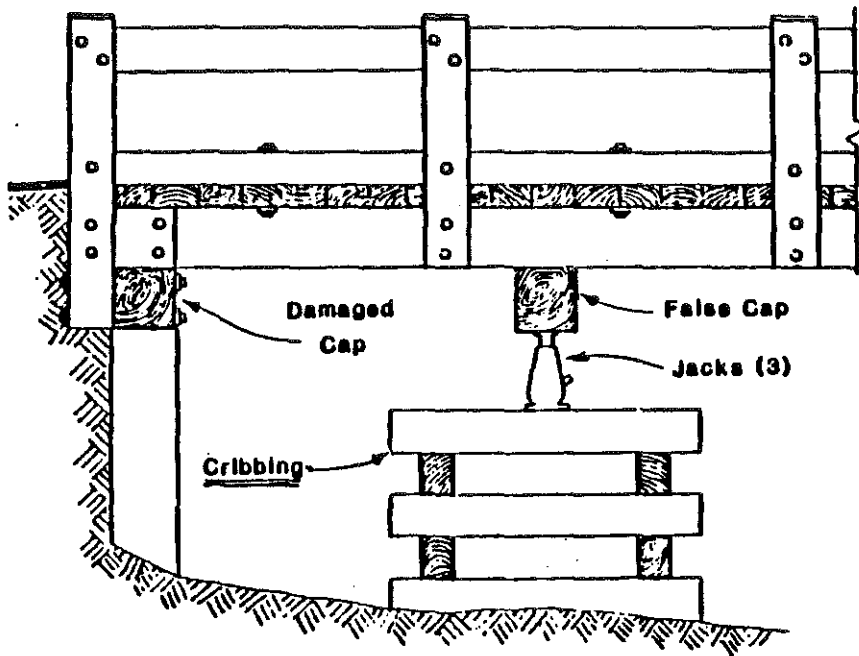

Figure 57. Use of Cribbing to Support a Bridge.

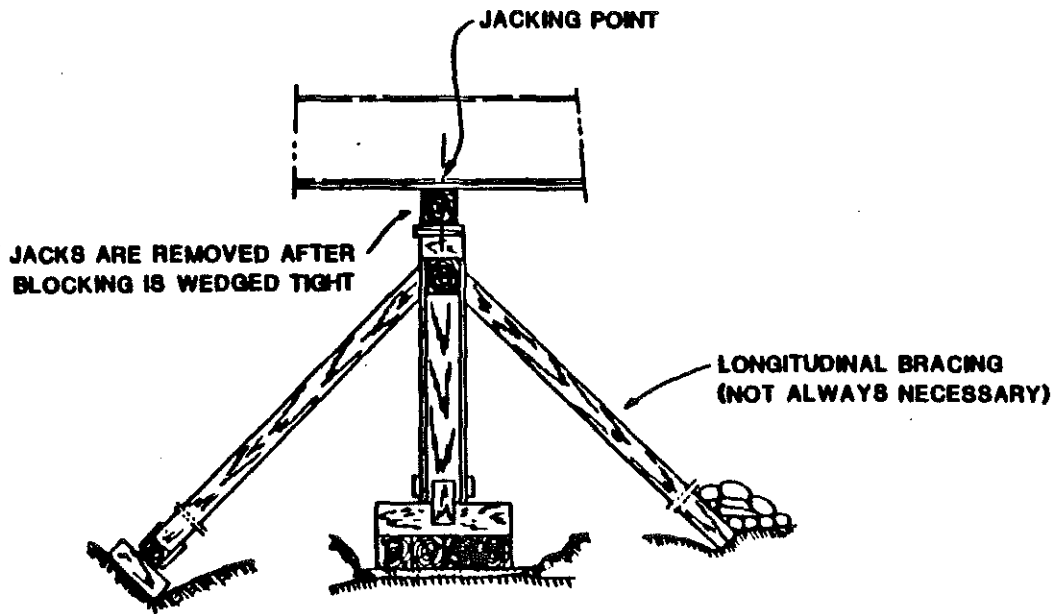

Figure 58. Use of Temporary Bent to Support a Bridge.

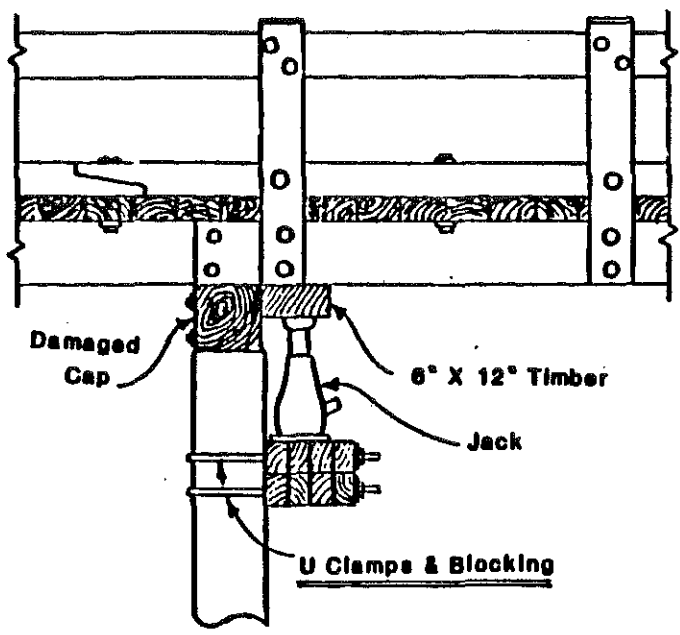

Figure 59. Use of Hydraulic Jacks to Raise a Bridge.

An obvious use for jacking the superstructure is to repair or to replace damaged bearings. Before doing this, one should make sure that the problem is the bearing and not movement of a pier or abutment. If replacement is required, elastomeric bearing pads should be considered, due to their ease of installation.

Concrete beams often may show distress at the beam ends, partially due to lack of suitable bearing material. Usual repairs at concrete beam ends involves temporary support, removal of bad concrete, welding on new reinforcing steel, placement of a bonding compound on the exposed concrete, forming, casting a new end, addition of a new bearing pad, and lowering the bridge (Figure 60).

Spalled or broken concrete on prestressed concrete girder bridges can also be repaired (Figure 61). All loose concrete should be removed and the surface water-blasted. Cracks should be chipped to a 1/2-inch deep V-groove. Forms should be placed around spalls, exposed surfaces covered with epoxy, and new concrete placed. Cracked areas should be filled with epoxy.

Cracked timber stringers can be repaired without floor removal (Figure 62). The wearing surface above the damaged timber is removed. Holes are drilled through the deck for draw-up bolts. Retaining and support plates are placed and the draw-up bolts are tightened. The wearing surface is replaced.

A decayed or cracked stringer may be reinforced (Figure 63). The deck is jacked up on both ends. Cut a wedge on one end of the new stringer and bevel the corners on the other end. Place the wedged end of stringer on the cap. Put a come-along on the beveled end of the stringer and attach it to the cap over the beveled end. Pull the wedged end over its cap with the come-along. Add a wedge to the wedged end by nailing.

Truss diagonal eyebars may be replaced with U bolts and connections (Figure 64). Sometimes for larger lower-chord eyebars, welded reinforcement may be added to increase or assure bearing on the pin (Figure 65).

### **6.3.5 Non-Structural Bridge Repairs**

Deck-armored edges and typical sliding-plate assemblies may be easily repaired. Loose armored edges can be repaired by removing concrete around the armored edge, rewelding the steel strap to the reinforcing steel, and replacing the concrete (Figure 66).

For another sliding-plate repair, a hole is torch cut in the sliding plate (Figure 67). Then a hole is cut at 45° through the deck. A 6-inch x 6-inch x 1-inch opening is placed at the hole exiting point in the deck. A rod threaded on one end is inserted in the hole. It is welded to the sliding plate. The threaded end on the underside of the deck is tightened. Then, the opening is filled with epoxy to cover the threaded connection.

A major weakness in early bridge designs has been the drainage systems, or lack thereof. Leaks at sliding-plate and finger-dam joints deposit water on bearings and pier caps and cause damage. Bridges have had undersized or easily clogged drains or drains having short outlets that deposit water onto girders and piers.

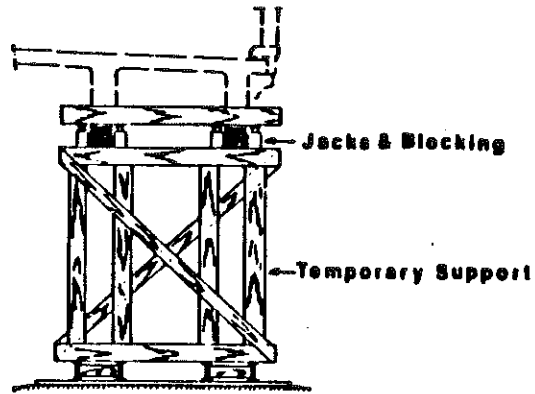

PARTIAL TRANSVERSE SECTION

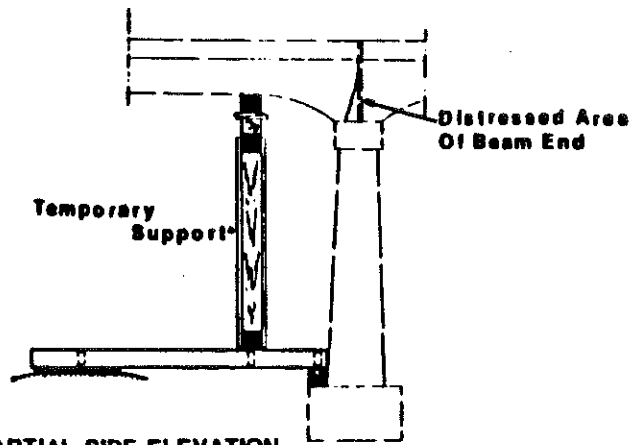

PARTIAL SIDE ELEVATION

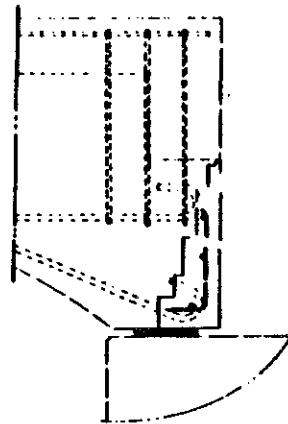

DETAIL OF REPAIRED AREA

Figure 60. Repair of a Concrete Beam End.

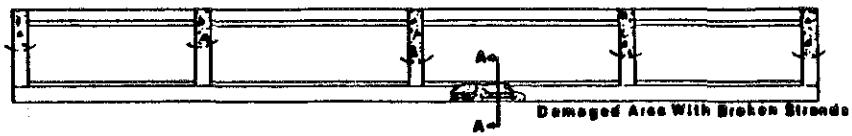

TYPICAL DAMAGED AREA OF A PRESTRESSED CONCRETE BRIDGE BEAM

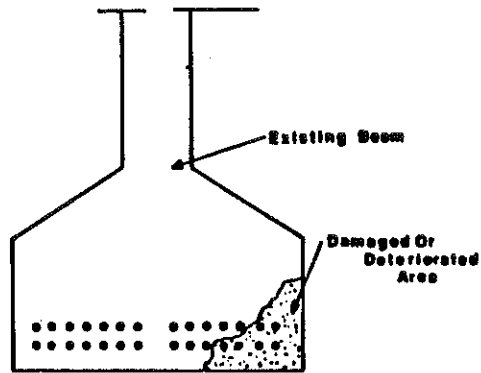

SECTION A-A

DAMAGED AREA

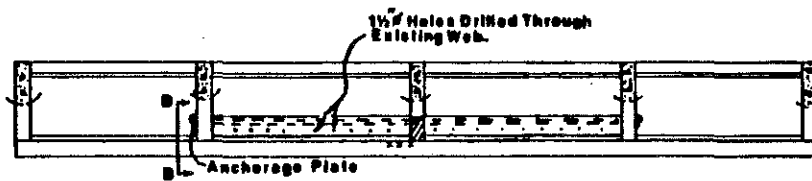

TYPICAL REPAIR BY ADDING POST-TENSIONED STRANDS

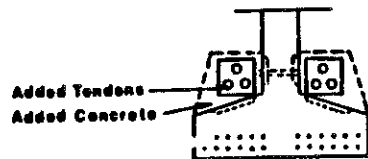

SECTION B-B

ADDED TENDONS TO STRENGTHEN THE BEAM

Figure 61. Repair of Spalled or Broken Prestressed Concrete Girders.

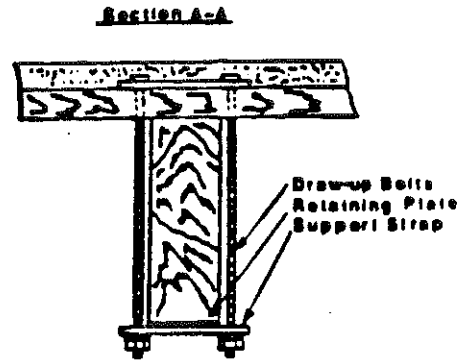
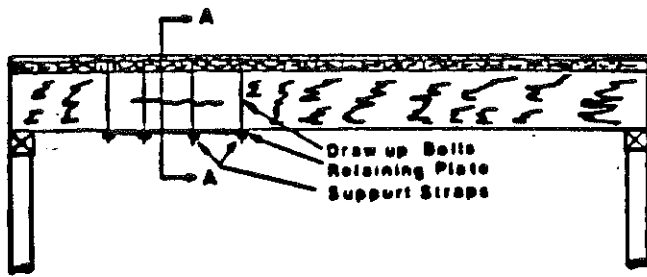
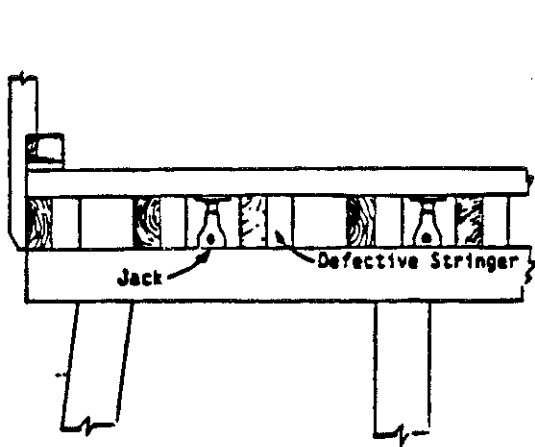
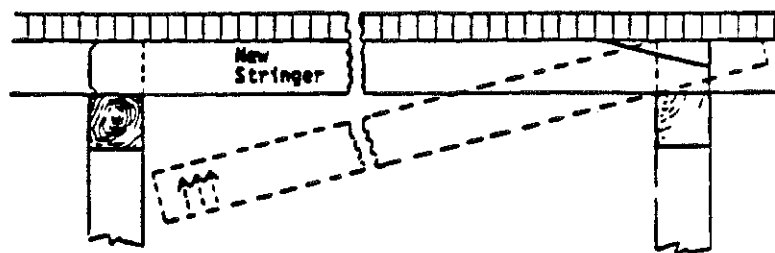

Figure 62. Repair of Cracked Wooden Stringers.



TYPICAL JACKING ARRANGEMENT



ERECTION SCHEME



NEW STRINGER

Figure 63. Replacement of Defective Wooden Stringers.

**NOTE: DETERIORATED DIAGONAL TENSION MEMBERS CONSISTING OF TWO EYE BARS CAN BE REPLACED USING RODS AS SHOWN WITH U-BOLT END CONNECTIONS.**



**NEW DIAGONAL MEMBER**

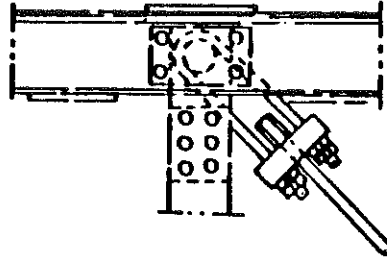

**Figure 64. Truss Diagonal Replacement for Pinned End Connections.**

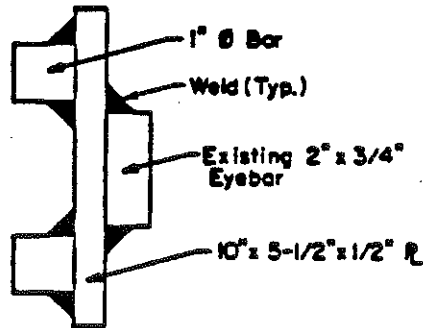
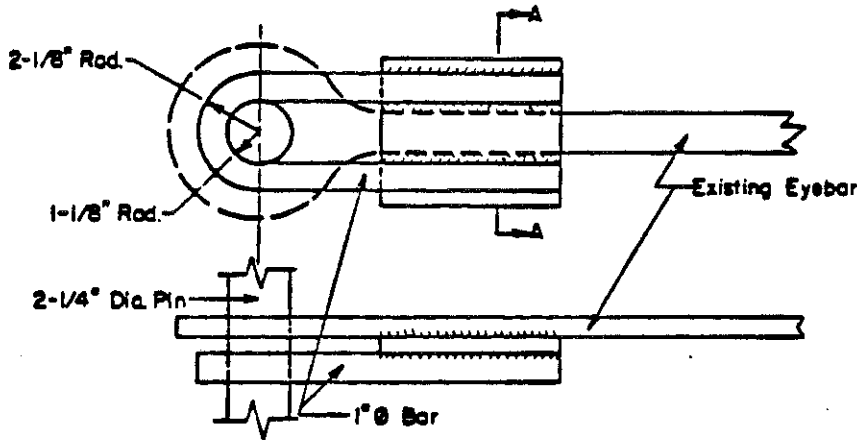

**Figure 65. Repair of Lower Chord Eyebar Head.**



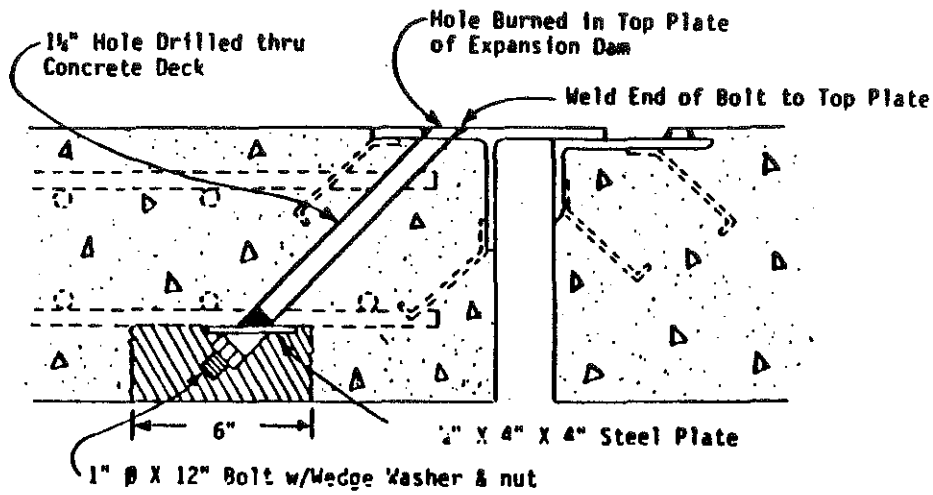

Figure 66. Repair of Sliding Plate Armored Expansion Joint.

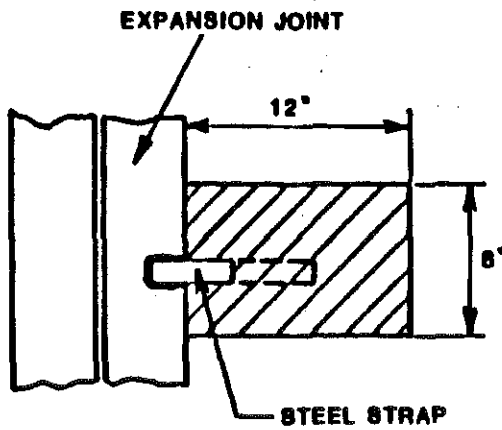
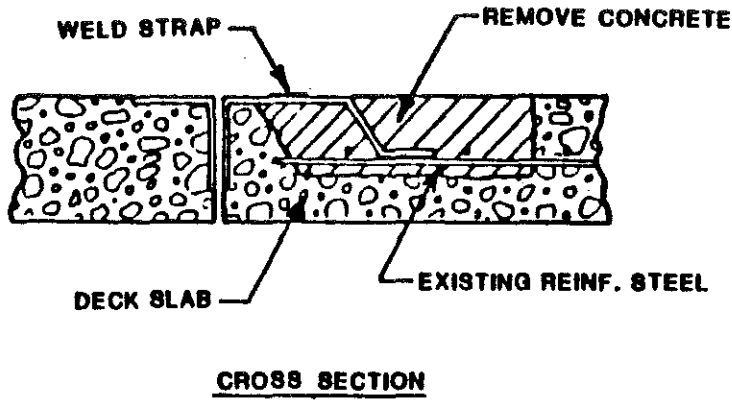

Figure 67. Repair of Loose Armored Edge.

One way to retrofit leaky or open deck joints is to retrofit drainage troughs under the joints. An easy way to do this is to use a flexible sheet material such as neoprene to form the joint and extra material is provided to form the trough and provide for joint movement (Figure 68). Flashing should be placed at each edge of the joint to prevent deterioration.

Bridge decks should be checked for adequate drainage by a knowledgeable engineer. He should be able to recommend the size and placement of additional drains (Figure 69). Try to stick with drainpipe and inlets at least 4 inches in diameter. Also, consider welding extensions to drain outlets depositing water onto the structure. If this is not possible, add splash diverters to the concrete or metal surfaces of the piers or girders to prevent washing damage (erosion etc.).

Decayed or substandard parapets may be replaced by precast GM or New Jersey style parapets (Figure 70). A common installation is to drill holes through the deck, insert threaded rods to affix the parapet and fill the hole with grout.

## 6.4 CULVERT REPLACEMENT

Culvert replacement is necessary when a culvert becomes hydraulically or structurally inadequate. Specific options available depend on the size and depth of the existing culvert and the excavation, construction, and traffic problems anticipated. An engineering analysis is recommended for all situations where culvert replacement is apparently needed. Typical alternates include

1. insertion of a smaller culvert inside the larger culvert for those situations where hydraulic analyses indicate feasible;
2. tunneling and jacking a new culvert into place; and
3. excavation, removal of the old culvert, and placement of a new culvert to meet hydraulic requirements for the site.

Proper installation is essential for adequate structural and hydraulic performance and for a long service life of a culvert. Proper alignment is important to reduce or eliminate scour. Grading and placement of the culvert to match the flowline of the existing channel is necessary to prevent accumulation of sediment in the culvert bottom if the culvert is too low or to prevent scour and/or ponding if the culvert is placed too high. Bedding provides a foundation for the culvert to prevent differential settlement, which may cause joint separation and/or cracking.

Culvert sections must be handled carefully to prevent damage. Structural integrity may be reduced as a result of dents, or bends, and therefore increase the potential for collapse under severe loading conditions. Scrapes and scuffs may damage the protective coating of metal culverts, creating the potential for early corrosion. Similarly, scrapes and scuffs of concrete culverts may result in areas more susceptible to environmental damage and potential corrosion of reinforcement steel.

Culvert sections may be linked together by several techniques. Steel plates or bands are used to connect metal sections. Concrete culvert sections are often constructed with a bell and spigot (tongue and

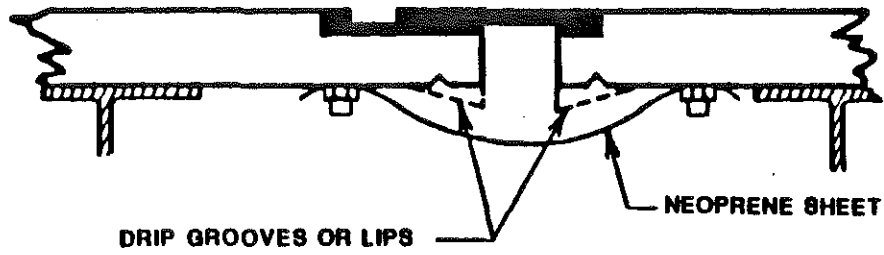

Figure 68. Trough Installation for Leaky Deck Joints.

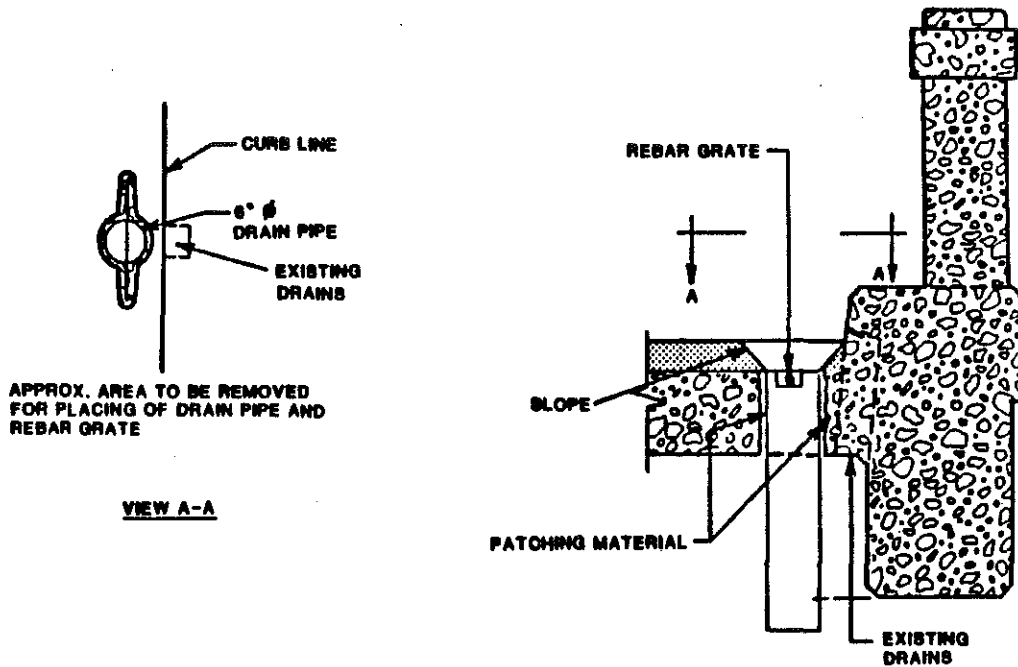

Figure 69. Addition of a Pipe Drain.

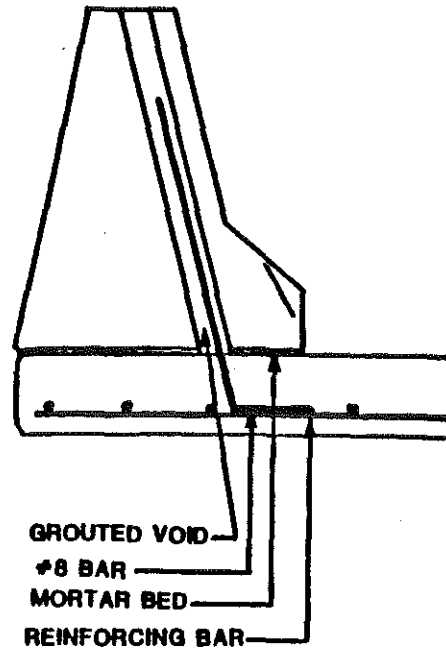

Figure 70. Installation of a Precast New Jersey-Type Parapet.

groove) end configuration to form a joint. Joints may be sealed with mastics, rubber gaskets, or mortar grout. Culvert sections should be laid starting at the downstream end.

Proper backfilling is necessary to attain the designed serviceability and structural integrity of the culvert (Figure 71). Backfill material consisting of good soil without large stones should be placed in symmetrical lifts 6 inches thick. Backfill material should be added to either side of the culvert at the same time to equally distribute the load on the culvert and to prevent distortion. Initial compaction is typically best accomplished by hand tamping. Mechanical compactors may be used when backfilling has been completed to a grade level greater than the height of the top of the culvert. Heavy equipment should not be used to cross an embankment until the embankment cover is at least 4 feet above top of the culvert.

## 6.5 LOW-COST BRIDGES AND WATER CROSSINGS

When bridges need to be removed, temporary bridges (Bailey and Accrow) can be rapidly put into place (Figure 72). If a local jurisdiction has a large bridge inventory and many bridges scheduled for replacement, purchase of several of those portable bridges should be considered.

The Kentucky Department of Highways occasionally dismantles older bridges of historical interest or significance. Many of those would not meet modern load or geometric standards, but would be acceptable for access bridges in remote locations. The Department of Highways will dismantle the bridge and furnish it to the erection site at no cost. In turn, the new owner must erect the bridge in accordance with its historical design (i.e., with all ornamentation). As the cost of erection, and abutment (and possibly pier) construction would be the only costs borne by the local government, this would be a good low-cost bridge erection opportunity. Also, it might be possible to acquire other non-historical bridges or bridge components that are being dismantled by the state or even by other local government units.

Occasionally, there is a need for a light bridge for pedestrian or low-volume, light vehicle crossings. Those needs may best be met using prefabricated steel bridges (Figure 73). These structures, fabricated almost to completion in the shop, are shipped in lengths up to 70 feet. They are easily lifted into place and usually require only bolting for assembly. The bridges can be furnished in painted or self-weathering steels. They also can be purchased and installed under turnkey-contracts with manufacturers.

Prestressed box beams may be used to quickly build a bridge. The upper flanges can be used as the riding surface if traffic volumes are low.

Where a water crossing has little traffic and the water flow is nominal, fords (also called dips or causeways) may be used (Figure 74). Fords are located at streambed level.

## 6.6 WORKER AND MOTORIST SAFETY

Whenever traffic will be affected by work on a bridge, traffic control must be provided to protect motorists and to safeguard workers. There are specific ways that either the whole bridge or a single lane must be closed for repairs. Traffic regulations are specified in Part 6 of the *Manual on Uniform Traffic*

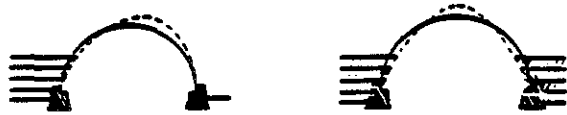

COMMON MISTAKES IN BACKFILLING ARCHES



RECOMMENDED BACKFILLING PRACTICE



SIDE VIEWS - Without and With Headwalls

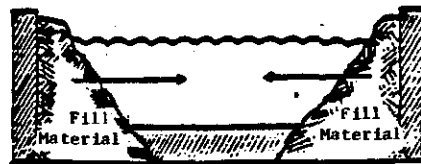

BACKFILLING PRACTICE FOR CORRUGATED STEEL ARCHES

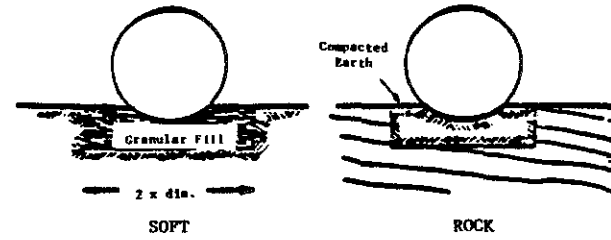

LEFT: Unstable foundation material should be removed below grade line and replaced with sand, gravel, crushed stone or other suitable material.  
 RIGHT: When rock is encountered in the foundation, it should be excavated to at least 6 in. below the bottom of the structure.

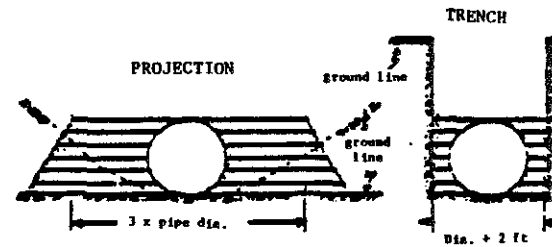

Backfill should be replaced in uniform, well tamped 6 in. layers on both sides of the structure.

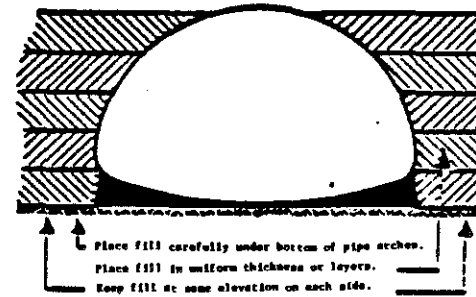

Compaction under the corners at pipe-arches is important

Figure 71. Foundation, Bedding, and Backfill Procedures.

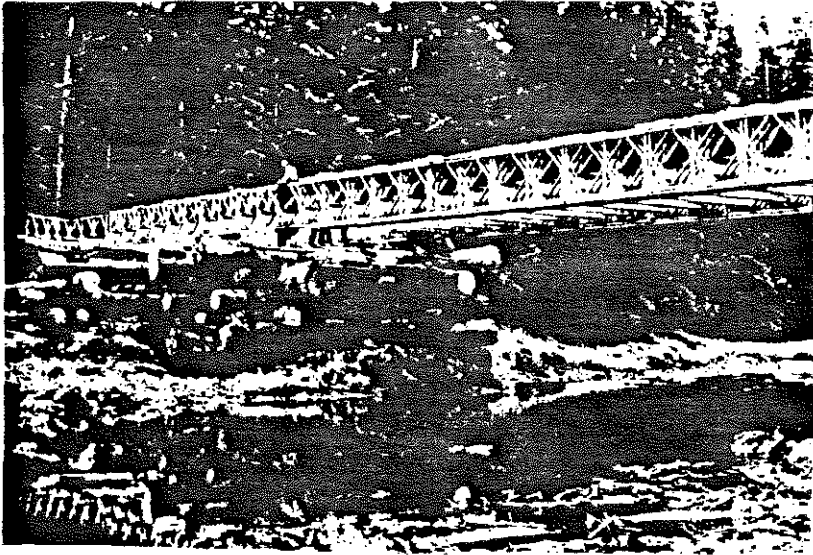

Figure 72. Portable Bridge (Acrow) Installation.

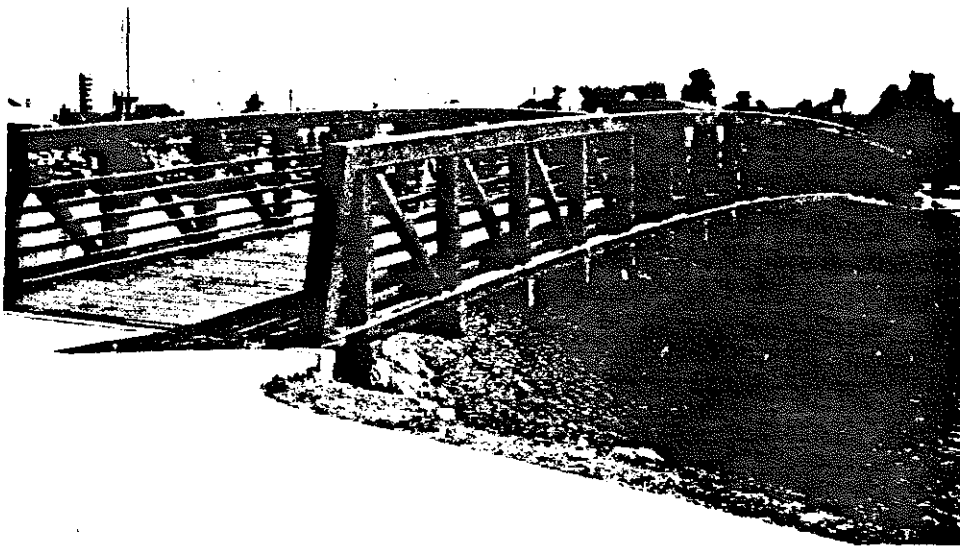

Figure 73. Light Prefabricated Steel Bridge.

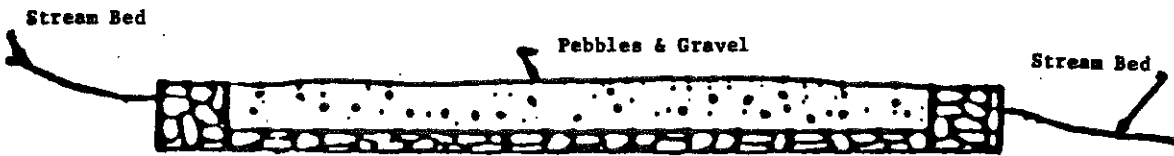

Figure 74. Low-Water Crossing (Ford).



**Control Devices**, entitled "Traffic Controls for Street and Highway Construction and Maintenance Operations." The manual should be used to plan and properly lay out detours.

The traffic control area for lane closure consists of five stages: 1) the advance warning area, 2) the transition area, 3) the buffer space, 4) the work area, and 5) the termination area (Figure 75). Each area must be laid out with care. For temporary repairs, where one-lane traffic must be maintained, flagmen are necessary. If only one lane of a two-lane road is to be closed at night, traffic signals must be employed. Flagmen should wear orange vests and have flags that meet KYDOH standards. Proper locations of flagmen, signing, and delineators (cones and/or barrels) are a necessity.

Signing for bridge work is very important, especially when lane closure or other traffic changes are involved. Remember that motorist must be warned of impending work (black-on-orange signs) and also must have at least 500 feet of vision on the roadway to the advance warning area (the point where the flagman is stopping traffic). If a bridge is just over a small hill, the flagman should be placed at the top of the hill. The motorist should have 500 feet to see the flagman, not the bridge. Two cases for two-lane, two-way roads subject to closure of one lane for a bridge repair will be discussed.

The first case will be for a road having less than 500 vehicles per day total traffic. If the speed limit is low (35-45 miles per hour), the warning signs (such as Flagman Ahead) should be located 500 feet from the work site, except as previously noted for vision obstructions. Beware of movable vision obstructions on the roadside, such as hay wagons.

The second case is for high-volume roads having more than 500 vehicles per day. The first warning sign should be a minimum of 1 mile from the work site. Every 500 feet, from 1500 feet on, there should be signs, "Construction 1500 feet," "Construction 1000 feet," etc. The signing should be placed with regard to the amount of traffic that will be delayed due to the lane closure. During rush hours, the first warning signs should be sufficiently far from the work site to allow motorist warning before they must reduce speed.

Remember that these guides are not specific, but are only informative. Read and understand the referenced traffic manuals.

Laborers should be required to perform work safely. In the field, workers should wear hard hats and steel-toed boots. When they are working with power tools, they should be required to wear safety glasses. Workers operating at heights should be securely tied off to prevent injury from falls. An informative source for safe working procedures is the "Kentucky Occupational Safety and Health Standards for General Industry", available from the Kentucky Department of Labor.

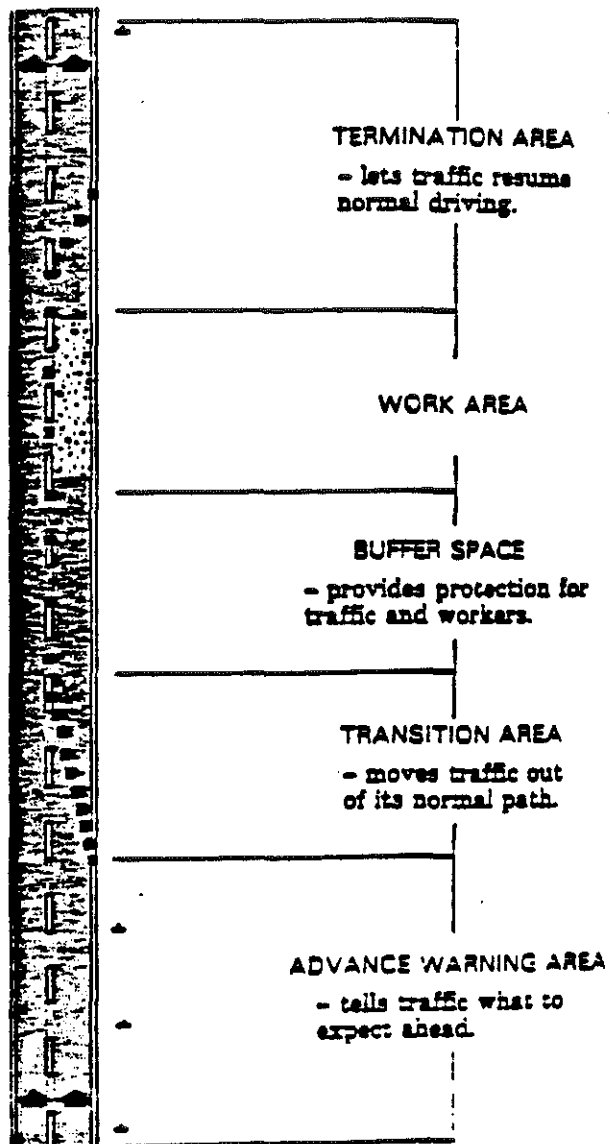

Figure 75. Five Stages of Traffic Control for Work-Zone Safety.

## 7.0 SPECIFICATIONS, STANDARDS, AND CODES

Standards, specifications, and codes exist and cover a large number of activities related to the maintenance of local bridges and culverts. Such standards can effect everything the local official does, every service contracted for, and any item purchased. They are, in a legal sense, a contract and a safeguard to protect the organization. They insure that the bridge official gets what he pays for. If the work is done by governmental crews, those standards may help assure that work is done correctly and safely.

### 7.1 PURPOSES OF SPECIFICATIONS, STANDARDS, AND CODES

Standards and codes often are created by national or regional consensus groups. They usually represent the latest state of knowledge and should not be altered by the local bridge official or by anyone with whom he contracts. When contracting for work, the bridge official may write specifications for a particular project or piece of equipment. Those specifications may refer to other standards, specifications, and codes.

When planning complex or expensive contract work, specification preparation should be considered an important part of the work. A consulting engineer can prepare bridge-related specifications (and see that they are met).

There are several things that a specification is not. It is not a tool to pry extra or free work from a contractor. More importantly, it does not release the bridge official from his obligation to inspect the contractors' materials and workmanship. A specification is only as good as it is enforced. Once the work is completed, the bridge official will receive more criticism for a bad job than the contractor. Therefore, he must test or examine materials the contractor uses and also must inspect the contractor's workmanship. The bridge official should control the contractor's activities so the work will not be done when weather may damage the construction.

### 7.2 KENTUCKY STANDARD SPECIFICATION MANUAL

A handy specification related to highway construction is the Kentucky Transportation Cabinet *Standard Specifications for Road and Bridge Construction*. It is available from the Transportation Cabinet, Department of Administration Services, State Office Building, Frankfort, Kentucky 40622, for twelve dollars.

The book contains the Kentucky Department of Highways specifications related to fabrication, construction, materials, inspection, and payment. This covers a variety of structures and components including bridges, culverts, wingwalls, guardrails, pavement overlays, and piles. Requirements for a wide range of materials including steel, cement, concrete, asphalt, paint, aggregate, and wood are included. If properly used, it can be a time-saver when planning and implementing a job. Also, the Transportation Cabinet has Standard Drawings, which specify some design standards for bridge components and signing.

Occasionally, the Transportation Cabinet upgrades certain specifications by issuing Special Provisions to modify, replace, or add a specification.

Remember that, when a specification is made binding by contract, it usually becomes a clause in that contract and becomes irrevocable. If a job is designed in accordance with a 1983 standard and a contract is signed to that effect, even if the 1983 specification has been replaced by a newer specification, the original specification governs. Change orders must be mutually prepared and executed to effect changes in specifications, materials, or procedures after the contract is signed.

### **7.3 DESIGN CODES**

There is one major design code for bridges. It is the American Association of State Highway and Transportation Officials (AASHTO) *Standard Specifications for Highway Bridges*. A design specification tells the engineer what constraints he has on designing the structure. That is, how strong he should make the bridge and how the common civil engineering materials should be employed in it. Engineers doing bridge design should become familiar with the specification.

### **7.4 WORKMANSHIP CODES**

Workmanship requirements are contained in many specifications and codes. The American Welding Society "Structural Welding Code D1.1" not only states how good the welding should be, but also advises on prequalifying the welder. Specifications such as the American Welding Society "Certified Welding Inspector" program on requirements for inspectors also exist.

### **7.5 MATERIAL CODES**

Bridge materials and components are covered by the American Society for Testing and Materials standards. These standards not only deal with many of the materials, but also outline how acceptance tests are to be performed. Many specifications used by the Kentucky Transportation Cabinet refer to ASTM standards. Those are published yearly and consist of a 50-60 volume set.

## **8.0 BUDGETING AND RESOURCE ALLOCATION**

### **8.1 REPLACEMENT AND REHABILITATION DECISIONS**

The rehabilitation or replacement of a bridge can be an item of great significance in the budget of any transportation agency. Pertinent factors that should be considered in making decisions relating to rehabilitation and/or replacement of a bridge structure follow.

The first step in the process of making a decision as to whether a bridge should be replaced or rehabilitated is a thorough evaluation of the existing structure. Evaluations may be available by appropriate state agencies. If such evaluations are not available, a professional engineer or trained bridge inspector should conduct an inspection to determine the specific condition of the existing structure. The inspection should address the condition of the waterway or stream channel, abutments and piers, bearings, beams or stringers, trusses, deck, wearing surfaces, and approaches.

Specifics relating to the conditions of the above are discussed in greater detail in appropriate sections of the text.

#### ***8.1.1 Current and Future Needs***

Bridge rehabilitation or reconstruction projects should be conceived and designed to meet the needs of the location in which they are to be constructed. When reviewing a structure for possible rehabilitation or replacement, needs that should be considered are the traffic currently using the facility as well as the traffic expected to use the facility and the anticipated or projected future needs of the area to be served. Conditions that should be considered include

1. potential impact on future traffic resulting from industrial development,
2. zoning restrictions that might limit traffic,
3. physical features that might limit traffic,
4. development in other areas that might have some impact on traffic growth for the area,
5. potential for pedestrian traffic,
6. maintenance problems associated with snowfall in the area, and
7. special requirements such as clearances or school bus routes, etc.

#### ***8.1.2 Dimensions, Alignment, and Other Characteristics***

After establishing the requirements of the improved structure, they must be converted into physical dimensions and characteristics. Frequent heavy truck traffic will affect the width, the structural capacity, and the approaches. Dimensions and characteristics that should be considered include the width of the roadway, the alignment of the bridge and approach, and the load capacity required on the basis of anticipated future traffic. The width, alignment, and loading capacity of the replacement or rehabilitated structure should meet current and future needs for the area.

### **8.1.3 Cost of Providing a Structure to Meet Needs**

Estimated costs should be prepared for performing the work to correct the defects discovered and to make the necessary improvements. Cost estimates can be grouped into three categories:

1. Category I are those costs necessary to restore the existing structure to a satisfactory condition. Estimated costs should be broken down into structural elements.
2. Category II are those costs associated with upgrading the structure. Different estimates should be developed for each alternate plan.
3. Category III are those costs associated with the new replacement structure. Only those parts of the existing structure that will provide service equal to the replacement structure should be considered as components of the replacement structure.

### **8.1.4 Other Considerations**

**8.1.4.1 Life-Cycle Cost.** A life-cycle cost analysis includes all the identifiable costs to an agency, including the costs of investments or discount rates. Maintenance costs must be considered as well as salvage value.

**8.1.4.2 Benefit-Cost Ratio.** A benefit-cost analysis not only accounts for all of the costs for an agency as defined under life-cycle costs but also accounts for costs to users as well. Example costs to the user might include those associated with additional travel time to use a replacement structure because of realignment when compared with the existing location.

**8.1.4.3 Funding Sources.** Various funding agencies require specific minimum standards to make a project eligible for available funds. For example, there are specific minimum standards required for a project to be funded under the federal Bridge Replacement and Rehabilitation Program. An additional concern associated with outside funding sources involves the priority assigned the project. In some situations, the community cannot wait for funds to become available from such sources.

**8.1.4.4 Availability and Competence of In-House Forces.** Selection of a rehabilitation process also may be related to the ability of in-house forces to perform the required tasks. In-house personnel should not be expected to perform tasks beyond their ability or capacity to perform in a reasonable period of time. In-house work may be supplemented by contracting with private vendors to perform specific tasks or functions. Examples of specific tasks requiring special expertise include welding and concrete work.

**8.1.4.5 Availability and Competence of Local Contractors.** The selection of a rehabilitation project also may be related to the ability of local contractors to perform the needed tasks. Contractors must be used when in-house personnel do not have the expertise. The cost of such work increases with the distance contractors must travel to the work site, assuming all other factors equal. Also, some rehabilitation procedures or materials may be proprietary, which can further increase costs.

**8.1.4.6 Availability and Cost of Materials.** The availability and cost of materials for any project should be thoroughly investigated before any decision is made relative to selection of a specific rehabilitation procedure.

**8.1.4.7 Availability and Cost of Specialized Equipment.** The requirements for specialized equipment should be evaluated when alternatives for rehabilitation and replacement are being considered.

**8.1.4.8 Time Out of Service.** When considerable traffic uses a structure and the only possible detour is long, time out of service can be a critical concern. Choices may vary from the least expensive rehabilitation alternative that has the largest amount of out-of-service time to the most expensive rehabilitation strategy where traffic can be maintained and effective out-of-service time is minimized or eliminated.

**8.1.4.9 Aesthetics.** Bridges can be very prominent structures. The appearance of the completed project should be given some consideration when comparing preferences for one alternative versus another. A perfectly utilitarian structure can be an eyesore in some specific setting but have no impact in another area.

**8.1.4.10 Evaluations to Select the Best Alternative.** There is no magic rule or method to determine the best rehabilitation alternative or to make a decision whether to rehabilitate or replace. One "rule of thumb" indicates that if the repair cost is less than 30 percent of the replacement cost and the repaired structure will meet current and projected needs, it is better to repair. The selection of costs for use in evaluation of alternatives may have a significant bearing on the final selection. Perhaps the best method for evaluation involves listing the advantages and disadvantages of each alternate and associated costs (construction, life-cycle, user costs, salvage values, etc.). Various factors can be weighted and some mathematical function applied for relative comparison of alternatives.

## **8.2 ROLE OF BRIDGE AND CULVERT INVENTORIES AND INSPECTIONS**

A bridge and culvert inventory, complete with accurate component ratings, will be helpful. When funds are limited, the inventory helps pinpoint those bridges that should receive attention. If many maintenance problems exist and increased funding is possible, an accurate inventory will help convince mayors, judges, and commissioners of the needs. Photographs of bridge maintenance problems along with an itemized listing of bridge maintenance needs also is a useful convincer.

## **8.3 ANNUAL BUDGET PREPARATION**

Every year a local bridge official or his supervisor must prepare a budget to cover bridge maintenance work. Often, this is a very busy time of the year with much head scratching and pencil sharpening. In theory, it is a very simple process -- planned expenditures must equal available funding. It can work several ways. Either the bridge officials have a fixed budget and must limit their work to fit that or they have a number of important needs for which money must be allocated. Also, this is a good time for

presenting plans for new operations such as a preventative maintenance program and for major equipment purchases.

The budget should include all costs to maintain or improve bridge maintenance operations for the year. Personnel budgeting should include not only workers' hourly rates, but also their overhead costs and provisions for any raises. If overtime is expected, it also should be accounted for in the budget. Equipment also should be budgeted. Quotes must be obtained for the items to be purchased. It is customary to obtain at least three quotes for major purchases (say over \$300). The quotes should be effective for a sufficient period to compensate for usual delays in funding. The local bridge official should determine the condition of existing equipment and plan for needed maintenance or replacement. It should be remembered that as equipment gets older, it needs more repairs. If the local bridge official is using last year's maintenance records to estimate repairs, he always should allow for aging. Routinely used materials can also be budgeted by examining prior purchase records to predict future use and costs. Do not neglect to include office equipment and supplies, utility costs, and maintenance of buildings and shop tools in budget requests.

Special projects such as large contract jobs must be planned well in advance of the required budget deadline. Again, quotes should be good for a sufficient period to assure it can be done if funded. Also, at least three quotes should be obtained for each project. However, it is usually not necessary to obtain design cost estimates on most small jobs.

#### **8.4 ROLE OF BUDGETING IN PLANNING WORK**

An approved budget is a mandate to perform the work outlined in the original budget proposal. Sometimes, the local bridge official needs to alter the scope of the work. He should request approval for those changes in writing from his superior. Infrequently, bridge failure will leave him scrambling for additional funds for bridge replacement or major repair. The local bridge official should not be too quick in agreeing to perform emergency work out of his annual routine budget. It may lead to lay-offs later.

#### **8.5 CONTRACT WORK VERSUS IN-HOUSE WORK**

One important question is, "Does one contract for work or do we do it with our own people?" Several questions need to be answered to arrive at a resolution of this issue. First, which way of doing the job will lead to lowest costs? Second, does the local bridge official have the people who can do the job? Is special equipment needed? Is there a seasonal or other time limit that requires more people than are available?

#### **8.6 DETERMINING PERSONNEL NEEDS**

One major problem the local bridge official will sometimes encounter is getting good workers. He will have an even harder time hiring people having special skills such as welders or mechanics. It is



usually difficult to keep skilled people with limited budgets of most local governments. If good salaries are not available, perhaps the local bridge official can pay the workers by giving them compensatory leave. Then, they can take that leave time in the winter when the amount of work slackens. Another way to compensate workers would be to adopt a short work week or give good vacation allowances.

The local bridge official should try to maintain the smallest full-time crew possible to get the work done. One way to do this is to try to get students or part-time workers for less demanding tasks during the busy summer months. Overtime is sometimes cheaper in the long-run than keeping extra workers. The local bridge official should try to get skilled workers paired with inexperienced workers. This will usually improve the work of the less experienced.

## **8.7 DETERMINING EQUIPMENT AND MATERIAL NEEDS**

Material and equipment needs will depend on work the local bridge official plans to do. If he can not pay enough to keep a good welder, there is no reason to have a welding machine. If he needs a piece of equipment infrequently, it can be leased rather than purchased. Otherwise, it would be wise to consider contract work rather than the purchase of an expensive piece of equipment. A major expenditure is training an operator for complicated equipment. To determine whether purchase of equipment is justified, one must determine how much the equipment will be used during the year. Then, one can compare the cost of the equipment to its lease price for as long as it will be needed per year times the number of years the equipment will be used. If there is a noticeable difference in favor of purchasing the equipment, it might be wise to buy it. If not, the equipment should be leased.

It is best to minimize material purchases. Materials must be stored until used. Often, they are subject to spoilage or other problems. Some materials such as paints must be stored under controlled temperatures. Stored materials also can be stolen. Salt should be stored in covered sheds. Materials that can be stored outside are aggregates and cinders. Savings may be realized from large purchases (by using bulk lubricants for instance). Spare metal parts should be kept from the elements to prevent corrosion.

## **8.8 SOME SMART MOVES**

Here are some rules of practice to keep the local bridge official out of trouble and to keep everything moving smoothly.

1. Do not allow a contractor to do design work. Hire a consulting engineer to determine designs -- never rely on contractor experience.
2. Try to avoid building skewed bridges or culverts.
3. When removing an old bridge, consider replacing it with a culvert. However, check with a consulting engineer first. Have him select and design the replacement structure. A culvert may not be the best choice.

4. If a bridge is in a curve and has suffered vehicle impact damage, it might be wise to straighten the road or to move the bridge to correct the alignment problem.

5. The approaches or bridge may need to be moved to correct vertical as well as horizontal misalignment.

6. The local bridge official must learn to trust his instincts. If he approaches a bridge and feels that more warning signs or different speed control signs are needed or that a roadway or bridge alignment modification is warranted, he is probably correct. He should try to change things.

7. If a farmer or factory is changing the stream flow near a bridge, the bridge official should check with an engineer to see that this change will not be harmful.

8. The local bridge official should not always try to build the cheapest bridge. A consultant may choose to use a longer span to avoid steep embankments near the bridge abutments. He is trying to prevent maintenance headaches in the future.

9. Investigate claims made by manufacturers' representatives.

10. The local bridge official should always have an inspector present when a contractor is working on a bridge. It is best to have someone who knows what the contractor is supposed to do. Also, one must inform the contractor that inspection is not necessarily an acceptance of his work.

11. The local bridge official should know his bridges.

## 9.0 RECOMMENDED READING

"Kentucky Department of Transportation Bridge Inspectors Training Manual", Planned Management Corporation, Tampa, Florida, 1978.

"Bridge Maintenance Inspection and Evaluation," White, K. R., Minor, J., Derucker, K. N., Heins, C. P., Jr., Morcel Dekker Publishing Co., New York, 1981.

"AASHTO Manual for Bridge Maintenance," American Association of State Highway and Transportation Officials, Washington, DC, 1976.

"Bridge Inspectors' Training Manual 70," U.S. Department of Transportation/Federal Highway Administration, Washington, DC, 1971.

"Training Course Workshop on Rehabilitation of Existing Bridges," Byrd, Tallamy, MacDonald and Lewis, Falls Church, Va, 1984 (Prepared for the Federal Highway Administration, Contract DTFH61-83-00163).

"Recording and Coding Guide for the Structure Inventory and Appraisal of the Nation's Bridges," U.S. Department of Transportation/Federal Highway Administration, Washington, DC, January 1979.

"Maintenance Practices for Local Roads -- Maintenance Techniques," Byrd, Tallamy, MacDonald and Lewis Consulting Engineers, Falls Church, Va (Prepared for the Bureau of Municipal Services, Pennsylvania Department of Transportation), September 1984.

"Street and Highway Maintenance Manual," American Public Works Association, 1985.

"Extending the Service Life of Existing Bridges by Increasing Their Load Carrying Capacity," Byrd, Tallamy, MacDonald and Lewis Consulting Engineers, Falls Church, Va, June 1978 (Prepared for the Federal Highway Administration, Report No. FHWA-RD-78-133).

"Manual for Maintenance Inspection of Bridges," American Association of State Highway and Transportation Officials, Washington, DC, 1974.

"Work Zone Traffic Control, Standards and Guidelines, 1985 Edition," U.S. Department of Transportation, Federal Highway Administration, Washington, DC, 1985.

## GLOSSARY

**ABUTMENT** -- A substructure composed of stone, concrete, brick, or timber supporting the end of a single span or the extreme end of a multi-span superstructure and, in general, retaining or supporting the approach embankment placed in contact therewith.

**AGGREGATE** -- The sand, gravel, broken stone, or combinations thereof with which the cementing material is mixed to form a mortar or concrete. The fine material used to produce mortar for stone and brick masonry and for the mortar component of concrete is commonly termed "fine aggregate" while the coarse material used in concrete is termed "coarse aggregate."

**ANCHORAGE** -- The complete assemblage of members and parts, whether composed of metal, masonry, wood or other material, designed to hold in correct position the anchor span of a cantilever bridge, the end of a suspension span cable, or a suspension span backstay; the end of a restrained beam, girder, or truss span; a retaining wall, bulkhead, or other portion or part of a structure.

**ANCHOR BOLT** -- A bolt-like piece of metal commonly threaded and fitted with a nut, or a nut and washer at one end only, used to secure in a fixed position upon the substructure the end of a truss or girder, the base of a column, a pedestal, shoe, or other member of a structure.

**APPROACH SLAB** -- A heavy reinforced concrete slab placed on the approach roadway adjacent to and usually resting upon the abutment back wall. The function of the approach slab is to carry wheel loads on the approaches directly to the abutment, preventing the transfer of a horizontal dynamic force through the approach fill to the abutment stem.

**APRON** -- A waterway bed protection consisting of timber, concrete, riprap, paving, or other construction placed adjacent to substructure abutments and piers to prevent undermining by scour.

**ARCH** -- In general, any structure producing at its supports reactions having both vertical and horizontal components. However, this definition is not intended to include structures of the rigid frame type, although applicable thereto, but instead to apply only to those having throughout their length a curved shape.

**ARMOR** -- A secondary steel member installed to protect a vulnerable part of another member, e.g., steel angles placed over the edges of a joint.

**AXLELOAD** -- The load of one axle of a vehicle, a movable bridge, or other motive equipment or device and transmitted through a wheel or wheels to a supporting structure.

**BACKFILL** -- Material placed adjacent to an abutment, pier, retaining wall or other structure or part of a structure to fill the unoccupied portion of the foundation excavation.

-- Soil, usually granular, placed behind and within the abutment and wing walls.

**BACK WALL** -- The topmost portion of an abutment above the elevation of the bridge seat, functioning primarily as a retaining wall with a live load surcharge. It may serve also as a support for the extreme end of the bridge deck and the approach slab.

**BACKWATER** -- The water of a stream retained at an elevation above its normal level through the controlling effect of a condition existing at a downstream location such as a flood, an ice jam, or other obstruction.

**BALLAST** -- Filler material, usually broken stone or masonry, used either to stabilize a structure (as in filling a crib) or to transmit a vertical load to a lower level (as with a railroad track ballast).

**BASE METAL, STRUCTURE METAL, PARENT METAL** -- The metal at and closely adjacent to the surface to be incorporated in a welded joint that will be fused; and by coalescence and interdiffusion with the weld, will produce a welded joint.

**BATTEN PLATES** -- 1. A plate used to cover the joint formed by two abutting metal plates or shapes but ordinarily not considered as serving to transmit stress from one to the other. 2. A plate used in lieu of lacing to tie together the shapes comprising a built-up member. 3. A term sometimes used as synonymous with Stay Plates to indicate a plate in which the bar latticing or lacing of a bolted, riveted, or welded member terminates.

**BATTER** -- The inclination of a surface in relation to a horizontal or a vertical plane or occasionally in relation to an inclined plane. Batter is commonly designated upon bridge detail plans as so many inches to one foot.

**BATTER PILE** -- A pile driven in an inclined position to resist forces that act in other than a vertical direction. It may be designed to withstand these forces or, instead, may be used as a subsidiary part or portion of a structure to improve its general rigidity.

**BEAD (Run)** -- A narrow continuous deposit of weld metal laid down in a single pass of fused filler metal.

**BEAM** -- 1. A simple or compound piece receiving and transmitting transverse or oblique stresses produced by externally applied loads, when supported at its end or at intermediate points and ends. The beam derives its strength from the development of internal bending or flexural stresses. 2. A rolled metal I-shaped or H-shaped piece. 3. An I-shaped piece or member composed of plates and angles or other structural shapes united by bolting, riveting, or welding. In general, such pieces or members are described as built-up beams. These terms are applied to and define, in general terms only, variations in shape, size, and arrangement of beam type members of reinforced concrete structures.

**REINFORCED CONCRETE BEAM** -- Reinforced concrete beam is a construction wherein the tensile stresses, whether resulting from bending, shear, or combinations thereof produced by transverse loading, are by design carried by the metal reinforcement. The concrete takes compression (and some shear) only. It is commonly rectangular or T-shaped with its depth dimension greater than its stem width.

**REINFORCED CONCRETE T-BEAM** -- Reinforced concrete T-beam derives its name from a similarity of shape to the letter "T", the head or topmost element of the letter consisting of a portion of the deck slab constructed integrally with the beam stem.

**BEARING FAILURE** -- Concerning the usual materials of construction, a crushing under extreme compressive load on an inadequate support; concerning soil, a shear failure in the supporting soil caused by excessively high pressures applied by a footing or pile.

**BEARING** -- A support or supporting part. A bearing that does not allow longitudinal movement.

**BEARING PAD** -- A thin sheet of material placed between a masonry plate and the masonry bearing surface used to fill any voids due to imperfection of the masonry plate and bearing surface, to seal the interface. Bearing pads may be made of alternating layers of red lead and canvas, of sheet lead, or of preformed fabric pads.

**BEARING SEAT** -- Top of masonry supporting bridge bearing.

**BEDROCK (Ledge Rock)** -- A natural mass formation of igneous, sedimentary, or metamorphic rock material either outcropping upon the surface, uncovered in a foundation excavation, or underlying an accumulation of unconsolidated earth material.

**BENT** -- A supporting unit of a trestle or a viaduct type structure made up of two or more columns or column-like members connected at their topmost ends by a cap, strut, or other member holding them in their correct positions. This connecting member is commonly designed to distribute the superimposed loads upon the bent, and when combined with a system of diagonal and horizontal bracing attached to the columns, the entire construction functions somewhat like a truss distributing its loads into the foundation.

**BERM (Berme)** -- The line, whether straight or curved, which defines the location where the top surface of an approach embankment or causeway is intersected by the surface of the side slope.

This term is synonymous with Roadway Berm. -- A horizontal bench located at the toe of slope of an approach cut, embankment, or causeway to strengthen and secure its underlying material against sliding or other displacement into an adjacent ditch, borrow pit, or other artificial or natural lower lying area.

**BLANKET** -- A protection against stream scour placed adjacent to abutments and piers and covering the stream bed for a distance from these structures considered adequate for the stream flow and stream bed conditions. The stream bed covering commonly consists of a deposit of stones of varying sizes that, in combination, will resist the scour forces. A second type consists of a timber framework so constructed that it can be ballasted and protected from displacement by being loaded with stone or with pieces of wrecked concrete structures or other adaptable ballasting material.

**BOLTED JOINT** -- See RIVETED JOINT

**BOND** -- 1. In reinforced concrete, the grip of the concrete on the reinforcing bars, thereby preventing slippage of the bars. 2. The mechanical bond resulting from irregularities of surface produced in the manufacturing operations is an important factor in the strength of a reinforced concrete member. For plain round bar reinforcement, it is the difference between the force required to produce initial slip and the ultimate, producing failure. Deformed bars utilize this mechanical bond in conjunction with the surface bond. 3. The mechanical force developed between two concrete masses when one is cast against the already hardened surface of the other.

**BOX BEAM** -- A rectangular-shaped precast, and usually prestressed, concrete beam. These beams may be placed side by side, connected laterally, and used to form a bridge deck, with or without a cast-in-place slab or topping. In such cases, the beam units act together similar to a slab. Where a cast-in-place slab is used and the units are placed, they act as beams.

**BOX GIRDER (CONCRETE)** -- A large concrete box-shaped beam, either reinforced or prestressed, usually multicelled with several interior webs. The bottom slab of the girder serves as a flange only, while the top slab is both a flange and a transverse deck slab.

**BOX GIRDER (STEEL)** -- A steel beam or girder, with a rectangular or trapezoidal cross section, composed of plates and angles or other structural shapes united by bolting, riveting, or welding, and having no interior construction except stiffeners, diaphragms, or other secondary bracing parts. Recently, large steel multicell boxes with interior webs have been used as have composite steel box girders in which a concrete slab forms the top of the box.

**BRACING** -- A system of tension or compression members, or a combination of these, forming with the part or parts to be supported or strengthened a truss or frame. It transfers wind, dynamic, impact, and vibratory stresses to the substructure and gives rigidity throughout the complete assemblage.

**BRACKET** -- A projecting support or brace-like construction fixed upon two intersecting members to function 1) as a means of transferring reactions or shear stress from one to the other, 2) to strengthen and render more rigid a joint connection of the members, or 3) to simply hold one member in a fixed position with relation to the other.

**BREAST WALL** -- The portion of an abutment between the wings and beneath the bridge seat. The breast wall supports the superstructure loads and retains the approach fill.

**BRIDGE** -- A structure providing a means of transit for pedestrians and/or vehicles above the land and/or water surface of a valley, arroyo, gorge, river, stream, lake, canal, tidal inlet, gut, or strait or above a road, highway, railway or other obstruction, whether natural or artificial. In general, the essential parts of a bridge are 1) the substructure consisting of its abutments and pier or piers supporting the superstructure, 2) the superstructure slab, girder, truss, arch, or other span or spans supporting the roadway loads and transferring them to the substructure, and 3) the roadway and its incidental parts functioning to receive and transmit traffic loads.

**BRIDGE (COMPOSITE)** -- A bridge whose concrete deck acts structurally with main longitudinal carrying members.

**BRIDGE (PRESTRESSED)** -- A bridge whose main carrying members are made of prestressed concrete.

**BRIDGE PAD** -- The raised, leveled area upon which the pedestal, shoe, sole, plate, or other corresponding element of the superstructure takes bearing by contact. Also called Bridge Seat Bearing Area.

**BRIDGE SEAT** -- The top surface of an abutment or pier upon which the superstructure span is placed and supported. For an abutment it is the surface forming the support for the superstructure and from which the back wall rises. For a pier it is the entire top surface.

**BRIDGE SITE** -- The selected position or location of a bridge.

**BUCKLE** -- To fail by an inelastic change in alignment (usually as a result of compression).

**BUTT WELD** -- A weld joining two abutting surfaces by depositing weld metal within an intervening space. This weld serves to unite the abutting surfaces of the elements of a member or to join members or their elements abutting upon or against each other.

**CAMBER** -- The slightly arched form or convex curvature, provided in a single span or in a multiple-span structure, to compensate for dead load deflection and to secure a more substantial and aesthetic appearance than is obtained when uniformly straight lines are produced. In general, a structure built with perfectly straight lines appears slightly sagged. This optical illusion is unsatisfactory and is most manifest in relatively long structures.

**CANTILEVER** -- A projecting beam, truss, or slab supported at one end only.

**CANTILEVER BRIDGE** -- A general term applying to a bridge having a superstructure of the cantilever type.

**CANTILEVER SPAN** -- A superstructure span of a cantilever bridge composed of two cantilever arms or of a suspended span connected with one or two cantilever arms.

**CAP (CAP BEAM, CAP PIECE)** -- The topmost piece or member of a viaduct, trestle, or frame bent serving to distribute the loads upon the columns and to hold them in their proper relative positions. -- The topmost piece or member of a pile bent in a viaduct or trestle serving to distribute the loads upon the piles and to hold them in their proper relative positions. See PIER CAP and PILE CAP.

**CAPILLARY ACTION** -- The process by which water is drawn from a wet area to a dry area through the pores of a material.

**CAPSTONE** -- 1. The topmost stone of a masonry pillar, column, or other structure requiring the use of a single capping element. 2. One of the stones used in the construction of a stone parapet to make up its topmost or "weather" course. Commonly, this course projects on both the inside and outside beyond the general surface of the courses below it.



**CATCH BASIN** -- A receptacle, commonly box-shaped and fitted with a grilled inlet and a pipe outlet drain, designed to collect water and floating debris from the roadway surface and retain the solid material so that it may be removed at intervals. Catch basins are usually installed beneath the bridge floor or within the approach roadway with the grilled inlet adjacent to the roadway curb.

**CATWALK** -- A narrow walkway for access to some part of a structure.

**CEMENT PASTE** -- The plastic combination of cement and water that supplies the cementing action in concrete.

**CEMENT MATRIX** -- The binding medium in a mortar or concrete produced by the hardening of the cement in the mortar, concrete mixture of inert aggregates.

**CENTER BEARING** -- The complete assemblage of pedestal castings, pivot, discs, etc., functioning to support the entire dead load of a swing span when the end lifts are released or the span is revolving to open or to closed positions.

**CHANNEL PROFILE** -- Longitudinal section of a channel.

**CHORD MEMBERS** -- Trusses are commonly divided lengthwise into panels, the length of each being termed a panel length. The corresponding members of the chords are described as upper, or top, chord members and lower, or bottom, chord members.

**CLEARANCE** -- The unobstructed space provided 1) in a through or half-through truss or a through plate girder type bridge and 2) upon a deck truss or girder type bridge for the free passage of vehicular and pedestrian traffic. Clearance is measured in vertical and horizontal (lateral) dimensions and may or may not be determined or regulated by standard (clearance diagram) requirements. Vertical clearance for vehicles is measured above the elevation of the floor surface at its crown dimension while horizontal clearance is commonly measured from or with reference to the edge of travel way.

-- The unobstructed space provided below a bridge superstructure for 1) the passage of a river or stream with its surface burden of floating debris, 2) the passage of navigation craft commonly designated "clear headway," and 3) the passage of vehicular and pedestrian traffic. This form of clearance is frequently designated "under-clearance" to differentiate it from the provision for the requirements of the transportation service supported by the structure.

**CLEAR SPAN** -- The unobstructed space or distance between the substructure elements measured, by common practice, between faces of abutments and/or piers. However, when a structure is located upon a stream, river, tidal inlet or other waterway used by navigation, the clear span dimension is measured at mean low water elevation and may be the distance between guard or fender piers, dolphins, or other constructions for the protection of navigation.

**CLEVIS** -- A forked device used to connect the end of a rod upon a gusset plate or other structural part by means of a pin. It commonly consists of a forging having a forked end arranged to form two eyes or eyelets for engaging a pin and a nut-like portion, constructed integrally therewith, for engaging the correspondingly threaded end of a rod.

**COFFERDAM** -- In general, an open box-like structure constructed to surround the area to be occupied by an abutment, pier, retaining wall, or other structure and to permit dewatering of the enclosure so that excavation for the preparation of a foundation and the abutment, pier, or other construction may be effected in the open air. In its simplest form, the dam consists of interlocking steel sheet piles.

**COLUMN** -- A general term applying to a member resisting compressive stresses and having, in general, a considerable length in comparison with its transverse dimensions. This term is sometimes used synonymously for "post."

**CONCRETE** -- A composite material consisting essentially of a binding medium within which are embedded particles or fragments of a relatively inert mineral filler. In portland cement concrete, the binder or matrix, either in the plastic or the hardened state, is a combination of portland cement and water. The filler material, called aggregate, is generally graded in size from fine sand to pebbles or stones that may, in some concretes, be several inches in diameter.

**CONSOLIDATION** -- The time-dependent change in volume of a soil mass under compressive load caused by pore water slowly escaping from the pores or voids of the soil. The soil skeleton is unable to support the load by itself and changes structure, reducing its volume and usually producing vertical settlements.

**CONTINUOUS GIRDER** -- A general term applied to a beam or girder constructed continuously over one or more intermediate supports.

**CONTINUOUS SPANS** -- A beam, girder, or truss type superstructure designed to extend continuously over one or more intermediate supports.

**CONTINUOUS TRUSS** -- A truss having its chord and web members arranged to continue uninterruptedly over one or more intermediate points of support, i.e., having three or more points of support.

**CONTINUOUS WELD** -- A weld extending throughout the entire length of a joint.

**CORROSION** -- The general disintegration and wasting of surface metal or other material through oxidation, decomposition, temperature, and other natural agencies.

**COUNTER** -- A truss web member that functions only when the span is partially loaded and shear stresses are opposite in sign to the normal conditions. The dead load of the truss does not stress the counter.

**COUNTERFORT** -- A bracket-like wall projecting from another wall to which it adds stability by being integrally built with or otherwise securely attached to the side and to which external forces are applied tending to overturn it. A counterfort, as opposed to a buttress, acts entirely to resist tensile and bending stresses. It may extend from the base either part or all the way to the top of the wall it is designed to reinforce.

**COURSE** -- In stone masonry, a layer of stone composed of either cut or uncut pieces laid with horizontal or slightly longitudinally inclined joints.

-- In brick masonry, a layer of bricks bedded in mortar.

**COVER** - In reinforced concrete, the thickness of concrete between the top of a reinforcing bar and the surface of the concrete.

**COVER PLATE** -- A plate used in conjunction with flange angles or other structural shapes to provide additional flange section upon a girder, column, strut, or similar member.

**COVERED BRIDGE** -- An indefinite term applied to a wooden bridge having in its construction a truss of any type. To prevent or delay deterioration of the timbers through infiltration of moisture into the framed or other joints, the entire structure, or instead, only its trusses are covered by a housing consisting of boards and shingles or other covering materials, fastened upon the side girts, rafters, purlins, or other parts intended to receive them. A covered bridge may be either a through or a deck structure. The former may be constructed with pony trusses.

**CRACKING (REFLECTION)** -- Visible cracks in an overlay indicating cracks in the concrete underneath.

**CREEP** -- An inelastic deformation that increases with time while the stress is constant.

**CRIB** -- A structure consisting of a foundation grillage combined with a superimposed framework, providing compartments or coffer that are filled with gravel, stones, concrete, or other material satisfactory for supporting the masonry or other structure to be placed thereon. The exterior portion may be planked or sheetpiled to protect the crib against damage by erosion or floating debris.

**CRIBBING** -- A construction consisting of wooden, metal, or reinforced concrete units so assembled as to form an open cellular-like structure for supporting a superimposed load or for resisting horizontal or overturning forces acting against it.

**CROSS FRAMES** -- Transverse bracings between two main longitudinal members.

**CROSS GIRDER (TRANSVERSE GIRDER)** -- A term applied to large timber members and to metal and reinforced concrete girder-like members placed generally perpendicular to and connected upon the main girders or trusses of a bridge span, including intermediate and end floor beams.

**CROWN OF ROADWAY** -- 1. The crest line of the convexed surface. 2. The vertical dimension describing the total amount the surface is convexed or raised from gutter to crest. This is sometimes termed the cross fall of roadway.

**CULVERT** -- A small bridge-like construction entirely below the elevation of the roadway surface and having no part or portion integral therewith. Structures over 20 feet in span parallel to the roadway are usually called bridges, rather than culverts; and structures less than 20 feet in span are called culverts even though they support traffic loads directly.

**CURB** -- A stone, concrete, or wooden barrier paralleling the side limit of the roadway to guide the movement of vehicle wheels and safeguard bridge trusses, railings, or other constructions existing outside the roadway limit and also pedestrian traffic upon sidewalks from collision with vehicles and their loads.

**CURVES IN PLAN AND PROFILE** -- A roadway may be curved in its lateral alignment, its vertical contour, or in both alignment and contour combined.

**DEAD LOAD** -- A static load due to the weight of the structure itself.

**DEAD MAN** -- A general term applied to an anchorage member engaging the end of a stay rod, cable, or other tie-like piece or part. The anchorage member is made secure through the resistance to movement produced by earth, stone, and brickbats.

**DECK** -- That portion of a bridge which provides direct support for vehicular and pedestrian traffic.

**DECK BRIDGE** -- A bridge having its floor elevation at, nearly at, or above the elevation of the uppermost portion of the superstructure.

**DECKING** -- A term specifically applied to bridges having wooden floors and used to designate the flooring only. It does not include the floor stringers, floor beams, or other members serving to support the flooring.

**DEPTH OF TRUSS** -- As applied to trusses having parallel chords and to polygonal trusses having a midspan length with parallel chords; the vertical distance between the centerlines of action of the top and bottom chords.

**DESIGN LOAD** -- The loading, magnitudes and distributions, of wheel, axle, or other concentrations used in the determination of the stresses, stress distributions, and ultimately the cross-sectional areas and compositions of the various portions of a bridge structure.

**DIAPHRAGM** -- A reinforcing plate or member placed within a member or deck system, respectively, to distribute stresses and improve strength and rigidity. See BRACING.

**DIKE (Dyke)** -- An earthen embankment constructed to provide a barrier to the inundation of an adjacent area that it encloses entirely or in part.

**DRAIN (Ditch, Gutter)** -- A trench or trough-like excavation made to collect water. In general, a drain is considered as functioning to collect and convey water whereas a ditch may only serve to collect it.

**DRAIN HOLE (Drip Hole)** -- An aperture extending through a wall to provide an egress for water that might otherwise accumulate on one side. In this connection the term weep hole and drain hole are commonly used.

**DRAINAGE** -- The interception and removal of water from the roadway and/or sidewalk surfaces of a bridge or its approaches; from beneath the paved or otherwise prepared roadway and/or

sidewalk surfaces of the approaches and from the sloped surfaces of hillsides, cuts, embankments, and causeways; from the backfill or other material in contact with abutments, retaining walls, counterweight wells, or parts of a bridge or incidental structure.

**EFFLORESCENCE** -- A white deposit on concrete or brick caused by crystallization of soluble salts brought to the surface by moisture in the masonry.

**END POST** -- The end compression member of a truss, either vertical or inclined in position and extending from chord to chord, functioning to transmit the truss end shear to its end bearing.

**EPOXY** -- A synthetic resin that cures or hardens by chemical reaction between components mixed together shortly before use.

**EXPANSION BEARING** -- A general term applied to a device or assemblage designed to transmit a reaction from one member or part of a structure to another and to permit the longitudinal movements resulting from temperature changes and superimposed loads without transmitting a horizontal force to the substructure.

**EXPANSION DAM** -- The part of an expansion joint serving as an end form for the placing of concrete at a joint. Also applied to the expansion joint device itself.

**EXPANSION JOINT** -- A joint designed to provide means for expansion and contraction movements produced by temperature changes, loadings, or other agencies.

**EXPANSION ROCKER** -- An articulated assemblage forming a part of the movable end of a girder or truss and facilitating the longitudinal movements resulting from temperature changes and superimposed loads.

**EXPANSION ROLLER** -- A cylinder so mounted that by revolution it facilitates expansion, contraction, or other movements resulting from temperature changes, loadings, or other agencies.

**EYEBAR** -- A member consisting of a rectangular bar body with enlarged forged ends or heads having holes through them for engaging connecting pins.

**FACE STONES** -- The stones exposed to view in the face surfaces of abutments, piers, arches, retaining walls, or other stone structures.

**FALSEWORK** -- A temporary wooden or metal framework built to support without appreciable settlement and deformation the weight of a structure during the period of its construction and until it becomes self-supporting. In general, the arrangement of its details are devised to facilitate the construction operations and provide for economical removal and the salvaging of material suitable for reuse.

**FASCIA GIRDER** -- An exposed outermost girder of a span sometimes treated architecturally or otherwise to provide an attractive appearance.

**FATIGUE** -- The tendency of a member to fail at a lower stress when subjected to cyclical loading than when subjected to static loading.

**FIELD COAT** -- A coat of paint applied upon the priming or base coat or upon a coat subsequently applied and, generally, after the structure is assembled and its joints completely connected by bolts, rivets, or welds. This application is commonly a part of the field erection procedure and is, therefore, termed field painting.

**FILL (Filling)** -- Material, usually earth, used for the purpose of raising or changing the surface contour of an area, or for constructing an embankment.

**FILLER METAL** -- Metal prepared in wire, rod, electrode, or other adaptable form to be fused with the structure metal in the formation of a weld.

**FILLET WELD** -- A weld joining intersecting members by depositing weld metal to form a near-triangular or fillet shaped junction of the surfaces of the members so joined. This weld serves to unite the intersecting surfaces of two elements of a member.

**FINGER DAM** -- Expansion joint in which the opening is spanned by meshing steel fingers or teeth.

**FIXED BEARING** -- The plates, pedestals, or other devices designed to receive and transmit to the substructure or to another supporting member or structure the reaction stresses of a beam, slab, girder, truss, arch, or other type of superstructure span.

**FLANGE** -- The part of a rolled I-shaped beam or of a built-up girder extending transversely across the top and bottom edges of the web. The flanges are considered to carry the compressive and tensile forces that comprise the internal resisting moment of the beam, and may consist of angles, plates, or both.

**FLOATING BRIDGE** -- In general this term means the same as "Pontoon Bridge." However, its parts providing buoyancy and support may consist of logs or squared timbers, held in position by lashing pieces, chains, or ropes, and floored over with planks, or the bridge itself may be of hollow cellular construction.

**FLOOR BEAM** -- A beam or girder located transversely to the general alignment of the bridge and having its ends framed upon the columns of bents and towers or upon the trusses or girders of superstructure spans. A floor beam at the extreme end of a girder or truss span is commonly termed an end floor beam.

**FLOOR SYSTEM** -- The complete framework of floor beams and stringers or other members supporting the bridge floor proper and the traffic loading, including impact thereon.

**FLOW LINE** -- The surface of a water course.

**FLUX** -- A material that dissolves and removes oxides from metal during the welding process. It may be in the coating on a metal stick electrode or a granular mass covering the arc in submerged arc welding and serves to protect the weld from oxidation during the fusion process.

**FOOTBRIDGE (Pedestrian Bridge)** -- A bridge designed and constructed to provide means of transverse for pedestrian traffic only.

**FOOTING (Footing Course, Plinth)** -- The enlarged, or spread-out, lower portion of a substructure, which distributes the structure load either to the earth or to supporting piles. The most common footing is the concrete slab, although stone piers also utilize footings. Plinth refers to stone work as a rule. Footer is a local term for footing.

**FORMS (Form Work, Lagging, Shuttering)** -- The constructions, either wooden or metal, providing means for receiving, molding, and sustaining in position the plastic mass of concrete placed therein to the dimensions, outlines, and details of surfaces planned for its integral parts throughout its period of induration or hardening.

**FORMS (SIP, Stay-In-Place)** -- A prefabricated metal concrete deck form that will remain in place after the concrete has set.

**FOUNDATION** -- The supporting material upon which the substructure portion of a bridge is placed. A foundation is natural when consisting of natural earth, rock, or near-rock material having stability adequate to support the superimposed loads without lateral displacement or compaction entailing appreciable settlement or deformation. Also, applied in an imprecise fashion to a substructure unit.

**CONSOLIDATED SOIL FOUNDATION** -- A foundation of soft soil rendered more resistant to its loads 1) by consolidating the natural material, 2) by the incorporation of other soil material (sand, gravel, etc.) into the soft material, and 3) by the injection of cementing materials into the soil mass.

**PILE OR PILED FOUNDATION** -- A foundation reinforced by driving piles in sufficient number and to a depth adequate to develop the bearing power required to support the foundation load.

**FOUNDATION EXCAVATION (Foundation Pit)** -- The excavation made to accommodate a foundation for a retaining wall, abutment, pier, or other structure or element thereof.

**FOUNDATION LOAD** -- The load resulting from traffic, superstructure, substructure, approach embankment, approach causeway, or other incidental load increment imposed upon a given foundation area.

**FOUNDATION PILE** -- A pile, whether of wood, reinforced concrete, or metal, used to reinforce a foundation and render it satisfactory for supporting superimposed loads.

**FOUNDATION SEAL** -- A mass of concrete placed underwater within a cofferdam for the base portion of an abutment, pier, retaining wall, or other structure to close or seal the cofferdam against incoming water from foundation springs, fissures, joints or other water-carrying channels.

**FRAME** -- A structure having its parts or members so arranged and secured that the entire assemblage may not be distorted when supporting the loads, forces, and physical pressures

considered in its design. The framing of a truss relates to the design and fabrication of the joint assemblages.

**FROST HEAVE** -- The upward movement of and force exerted by soil due to alternate freezing and thawing of retained moisture.

**FROST LINE** -- The depth to which soil may be frozen.

**GIRDER** -- A flexural member that is the main or primary support for the structure and that usually receives loads from floor beams and stringers.

**GIRDER BRIDGE** -- A bridge whose superstructure consists of two or more girders supporting a separate floor system of slab and floor beams, or slab, stringer, and floor beam, as differentiated from a multi-beam bridge or a slab bridge.

**GRADE SEPARATION** -- A term applied to the use of a bridge structure and its approaches to divide or separate the crossing movement of vehicular, pedestrian, or other traffic by confining portions thereof to different elevations. See OVERPASS.

**GRILLAGE** -- A platform-like construction or assemblage used to insure distribution of loads upon unconsolidated soil material.

**GROUT** -- A mortar having a sufficient water content to render it a free-flowing mass, used for filling (grouting) the interstitial spaces between the stones or the stone fragments (spalls) used in the backing portion of stone masonry; for securing anchor bolts and for filling cored spaces in castings, masonry, or other spaces where water may accumulate.

**GUARDRAILING (Guardrail, Guard Fence, Protection Railing)** -- A fence-like barrier or protection built within the roadway shoulder area and intended to function as a combined guide or guard for the movement of vehicular and/or pedestrian traffic and to prevent or hinder the accidental passage of such traffic beyond the berm line of the roadway.

**GUTTER GRATING** -- A perforated or barred cover placed upon an inlet to a drain to prevent the entrance of debris gathered and brought to the inlet by the water stream.

**H-BEAM (H-Pile)** -- A rolled steel bearing pile having an H-shaped cross section.

**HAUNCH** -- A deepening of a beam or column, the depth usually being greatest at the support and vanishing towards or at the center. The curve of the lower flange or surface may be circular, elliptic, parabolic, straight, or stepped.

**HEADWATER** -- The depth of water at the inlet of a pipe, culvert, or bridge waterway.

**HOWE TRUSS** -- A truss of the parallel chord type originally adapted to wooden bridge construction, but with the later development of metal bridge trusses, it was adopted only to a limited extent due to the uneconomical use of metal in its compression members. The web system is composed of vertical (tension) rods at the panel points with an X pattern of diagonals.



**HYDROPLANING** -- Loss of contact between a tire and the deck surface when the tire planes or glides on a film of water covering the deck.

**INTRADOS (Soffit)** -- The curved surface of an arch nearest its longitudinal (constructional) axis or axes. The intrados is the curve defining the interior surface of the arch.

**JOINT** -- In stone masonry, the space between individual stones.

-- In concrete construction, the divisions or terminations of continuity produced at predetermined locations or by the completion of a period of construction operations. These may or may not be open.

-- In a truss or frame structure, 1) a point at which members of a truss or frame are joined or 2) the composite assemblage of pieces or members around or about the point of intersection of their lines of action in a truss or frame.

**KING-POST (King Rod)** -- The post member in a "King-post" type truss or in a "King-post" portion of any other type of truss.

**K-TRUSS** -- A truss having a web system wherein the diagonal members intersect the vertical members at or near the mid-height. When thus arranged, the assembly in each panel forms a letter K; hence the name "K-Truss".

**KNEE BRACE** -- A member, usually short in length, engaging at its ends two other members that are jointed to form a right angle or a near-right angle. It thus serves to strengthen and render more rigid the connecting joint.

**KNEE WALL** -- A return of the abutment back wall at its ends to enclose the bridge seat on three of its sides. The returned ends may or may not serve to retain a portion of the bridge approach material, but do hide the bridge seat, beam ends, and bearings.

**LAMINATED TIMBER** -- Timber planks glued together to form a larger member. Laminated timber is used for frames, arches, beams, and columns.

**LAP JOINT** -- A joint in which a splice is secured by fixing two elements or members in a position wherein they project upon or overlap each other.

**LATERAL BRACING (Lateral System)** -- The bracing assemblage engaging the chords and inclined end posts of truss and the flanges of plate girder spans in the horizontal or inclined planes of these members to function in resisting the transverse forces resulting from wind, lateral vibration, and traffic movements tending to produce lateral movement and deformation. See BRACING.

**LATTICE (Latticing, Lacing)** -- An assemblage of bars, channels, or angles singly or in combination bolted, riveted, or welded in inclined position upon two or more elements of a member to secure them in correct position and assure their combined action.

**LATTICE TRUSS** -- In general, a truss having its web members inclined; but more commonly the term is applied to a truss having two or more web systems composed entirely of diagonal members at any interval and crossing each other without reference to vertical members.

**LEDGE COURSE** -- In masonry or concrete construction, a course forming a projection beyond the plane of a superimposed course or courses.

**LIVE LOAD** -- A dynamic load such as traffic load that is supplied to a structure suddenly or that is accompanied by vibration, oscillation, or other physical condition affecting its intensity.

**MASONRY** -- A general term applying to abutments, piers, retaining walls, arches, and allied structures built of stone, brick, or concrete and known correspondingly as stone, brick, or concrete masonry.

**MATTRESS** -- A mat-like protective covering composed of brush and poles, commonly willow, compacted by wire or other lashings and ties and placed upon river and stream beds and banks and lake, tidal, or other shores to prevent erosion and scour by water movement action.

**MEANDER** -- The tortuous channel that characterizes the serpentine curvature of a slow-flowing stream in a flood plain.

**MEMBER** -- An individual angle, beam, plate forging, casting, or built piece, with or without connected parts for joints, intended ultimately to become an integral part of an assembled frame or structure.

**MILLED** -- In steel fabrication, a careful grinding of an edge or surface to assure good bearing or fit.

**MORTAR** -- An intimate mixture, in a plastic condition, of cement or other cementitious material with fine aggregate and water, used to bed and bind together the quarried stones, bricks, or other solid materials composing the major portion of a masonry construction or to produce a plastic coating upon such constructions.

**NOTCH EFFECT** -- Stress concentration caused by an abrupt discontinuity or change in section. Such concentrations may have a marked effect on fatigue strength of a member.

**OVERPASS (Underpass)** -- The basic element is a separation of grades. The use of these terms is fixed by the relative elevations of the traffic ways involved; for the lower roadway, the structure is an underpass; for the upper roadway, an overpass.

**PANEL (Sub-Panel)** -- The portion of a truss span between adjacent points of intersection of web and chord members and, by common practice, applied to intersections upon the bottom chord.

**PANEL POINT** -- The point of intersection of primary web and chord members of a truss.

**PARAPET** -- A wall-like member composed of brick, stone, or reinforced concrete construction upon the retaining wall portion of an approach cut, embankment, or causeway or along the outermost edge of the roadway or the sidewalk portion of a bridge to serve as a protection to vehicular and/or pedestrian traffic.

**PEDESTAL** -- A cast or built-up metal member of assemblage functioning primarily to transmit load from one member or part of a structure to another member or part. A secondary function may be to provide means for longitudinal, transverse or revolution movements.

**PENETRATION** -- When applied to creosoted lumber, the depth to which the surface wood is permeated by the creosote oil.

-- When applied to welding, the depth to which the surface metal of the structure part (structure metal) is fused and coalesced with the fused weld metal to produce a weld joint. See WELD PENETRATION

-- When applied to pile driving, the depth a pile tip is driven into the ground.

**PIER** -- A structure composed of stone, concrete, brick, steel, or wood and built in shaft or blocklike form to support the ends of the spans of a multi-span superstructure at an intermediate location between its abutments.

**PIER CAP (Pier Top)** -- The topmost portion of a pier. On rigid frame piers, the term applies to the beam across the column tops. On hammerhead and tee piers, the cap is a continuous beam.

**PILE** - A rod or shaft-like linear member of timber, steel, concrete, or composite materials driven into the earth to carry structure loads through weak strata of soil to those strata capable of supporting such loads. Piles also are used where loss of earth support due to scour is expected.

**BEARING PILE** -- One which receives its support in bearing through the tip (or lower end) of the pile.

**FRICTION PILE** -- One which receives its support through friction resistance along the lateral surface of the pile.

**SHEET PILES** -- Commonly used in the construction of bulkheads, cofferdams, and cribs to retain earth and prevent the inflow of water, liquid mud, and fine grained sand with water. Three general types include 1) Timber composed of a single piece or of two or more pieces spiked or bolted together to produce a compound piece, either with a lap or a tongued and grooved effect. 2) Reinforced concrete slabs constructed with or without lap or tongued and grooved effect. 3) Rolled steel shapes with full provision for rigid interlocking of the edges.

**PILE CAP** -- Concrete footings for a pier or abutment supported on piles. Also applied to the concrete below the pile tops when footing reinforcing steel is placed completely above the piles.

**PILING (Sheet Piling)** -- General terms applied to assemblages of piles in a construction. See PILE.

**PIN** -- A cylindrical bar used as a means of connecting, holding in position, and transmitting the stresses of the members forming a truss or a framed joint. To restrain the pin against longitudinal movement, its ends are fitted with pin nuts, cotter bolts, or both.

**PIN-CONNECTED TRUSS** -- A general term applied to a truss of any type having its chord and web members connected at the truss joints by pins.

**PINION** -- The small driving gear on the power train of a movable bridge.

**PINION BRACKET** -- The frame supporting the turning pinion with its shaft and bearings upon the drum girder or the loading girder of a swing span.

**PIN JOINT** -- A joint in a truss or other frame in which the members are assembled upon a cylindrical pin.

**PLATE GIRDER** -- An I-shaped beam composed of a solid web plate with either flange plates or flange angles bolted, riveted, or welded upon its edges. Additional cover plates may be attached to the flanges to provide greater flange area.

**POINTING** -- The operations incident to the compacting of the mortar in the outermost portion of a joint and the troweling or other treatment of its exposed surface to secure watertightness or desired architectural effect or both.

**PONTOON BRIDGE** -- A bridge ordinarily composed of boats, scows, or pontoons so connected to the deck or floor construction that they are retained in position and serve to support vehicular and pedestrian traffic. A pontoon bridge may be so constructed that a portion is removable and thus serve to facilitate navigation. Modern floating bridges may have pontoons built integrally with the deck.

**PONY TRUSS** -- A general term applied to a truss having insufficient height to permit the use of an effective top chord system of lateral bracing above the bridge floor.

**POP-OUT** -- Conical fragment broken out of a concrete surface, normally about one inch in diameter. Shattered aggregate particles are usually found at bottom of hole.

**PORTABLE BRIDGE** -- A bridge so designed and constructed that it may be readily erected for a temporary communication-transport service; disassembled and its members again reassembled and the entire structure rendered ready for further service.

**PORTAL** -- The clear unobstructed space of a through bridge forming the entrance to the structure.

**POST** -- A term commonly applied to a relatively short member resisting compressive stresses, located vertical or nearly vertical to the bottom chord of a truss and common to two truss panels. Sometimes used synonymously for column.

**POSTED** -- A limiting dimension, speed, or loading, e.g., posted load, posted clearance, posted speed, indicating larger dimensions and higher speeds and loads cannot be safely taken by the bridge.

**POT HOLES** -- Small worn or disintegrated areas of bridge floor or approach surface concaved by the wearing action of vehicle wheels.

**PRIMING COAT (Base Coat)** -- The first coat of paint applied to the metal or other material of a bridge. For metal structures, this is commonly a fabricating shop application and is, therefore, termed the shop coat.

**RAILING (Handrail)** -- A wooden, brick, stone, concrete, or metal fence-like construction built at the side of the roadway, or the sidewalk, upon the retaining wall portion of an approach cut, embankment, or causeway or at the outermost edge of the roadway or the sidewalk portion of a bridge to guard or guide the movement of both pedestrian and vehicular traffic and to prevent the accidental passage of traffic over the side of the structure.

**RAMP** -- An inclined traffic way leading from one elevation to another. The general term is used to designate an inclined roadway and/or sidewalk approach to a bridge and commonly is applied to a rather steep incline.

**REBAR** -- A steel reinforcing bar.

**REINFORCING BAR** -- A steel bar, plain or having a deformed surface, which bonds to the concrete and supplies tensile strength to the concrete.

**RETAINING WALL** -- A structure designed to restrain and hold back a mass of earth.

**BUTTRESSED WALL** -- A retaining wall designed with projecting buttresses to provide strength and stability.

**COUNTERFORTED WALL** -- A retaining wall designed with projecting counterforts to provide strength and stability.

**GRAVITY WALL** -- A wall composed of brick, stone, or concrete masonry designed to be stable against sliding and rotation (overturning) upon its foundation or upon any horizontal plane within its body by virtue of its shape and weight.

**REINFORCED CONCRETE CANTILEVER WALL** -- A wall consisting of a base section integral with the stem, constructed approximately at a right angle thereto, giving its cross section a letter "L" or an inverted "T" shape. The stem portion resists the horizontal or other forces tending to produce overturning by acting as a cantilever beam.

**RIPRAP** -- Brickbats, stones, blocks of concrete, or other protective covering material of like nature deposited upon river and stream beds and banks and lake, tidal, or other shores to prevent erosion and scour by water flow, wave or other movement.

**RIVETED JOINT (Bolted Joint)** -- A joint in which the assembled elements and members are united by rivets. The design of a riveted joint contemplates a proper distribution of its rivets to develop its various parts with relation to the stresses and the purposes that each must serve. --

A bolted joint differs from a riveted one only in the use of bolts as the uniting medium instead of rivets. The conditions of design are generally the same, but different allowable unit stresses are employed.

**ROADWAY (Travel Way)** -- 1. The portion of the deck surface of a bridge intended for the use of vehicular or vehicular and pedestrian traffic. 2. The top surface of an approach embankment, causeway, or cut intended for the general use of vehicular or vehicular and pedestrian traffic. In general, its width corresponds to the distance curb to curb, to the distance between the outside limits of sidewalks, or to the width of the roadway pavement or traveled way when no curbs exist.

**ROADWAY SHOULDER AREA (Shoulder Area)** -- The portion or area of the top surface of an approach embankment, causeway, or cut immediately adjoining the roadway, used to accommodate stopped vehicles in emergencies and to laterally support base and surface courses.

**ROCKER BEARING** -- A cylindrical, sector-shaped member attached by a pin or trunnion at its axis location to the expansion end of a girder or truss and having line bearing contact upon its perimetral surface with the masonry plate or pedestal, thus providing for the longitudinal movements resulting from temperature changes and superimposed loads by a wheel-like translation.

**ROLLER** -- A steel cylinder forming an element of a roller nest or any other device or part intended to provide movements by rolling contact.

**ROLLER BEARING** -- A single roller or a group of rollers so housed as to permit movement of a part or parts of a structure thereon.

**ROLLER NEST** -- A group of steel cylinders forming a part of the movable end of a girder or truss and located between the masonry plate and shoe or pedestal to facilitate the longitudinal movements resulting from temperature changes and superimposed loads.

**SAFE LOAD** -- The maximum loading determined by a consideration of its magnitudes and distributions of wheel, axle, or other concentrations as productive of unit stresses in the various members and incidental details of a structure, permissible for service use, due consideration being given to the physical condition of the structure resulting from its previous service use.

**SAFETY CURB** -- A narrow curb between 9 inches and 24 inches wide serving as a refuge or walkway for pedestrians crossing a bridge.

**SAG** -- A deformation of an entire span; of any part of a span; or of one or more of its members from the horizontal, vertical, or inclined position intended as a condition of its original design and construction. This variation may result from elastic deformation of structural material, from irregularities produced by inadequate temporary supports during the progress of construction operations, or from incorrect adjustments and unworkmanlike procedures made a part of the work.

**SCOUR** -- An erosion of a river, stream, tidal inlet, lake, or other water bed area by a current, wash, or other water in motion, producing a deepening of the overlying water or a widening of the lateral dimension of the flow area.

**SCREW JACK AND PEDESTAL** -- An adjustable device or assemblage consisting of a screw operated within a fixed nut and having upon its bottom end a pedestal-like bearing conjoined

with it by a ball and socket or other equally adaptable articulation permitting its adjustment upon a shoe plate or pedestal fixed upon the bridge seat. When installed at each outermost end of the girders or the trusses of a swing span, their major function is to lift them to an extent that their camber or droop will be removed and the arms rendered free to act as simple spans.

**SCUPPER (Curb Inlet)** -- An opening in the floor of a bridge, commonly located adjacent to the curb or wheel guard, to provide means for water accumulated upon the roadway surface to drain through it into the space beneath the structure. Bridges having reinforced concrete decks with concrete curbs may be effectively drained through scuppers located within the curb face surfaces.

**SHEET PILE COFFERDAM** -- In general a wall-like, watertight, or nearly watertight barrier composed of driven timber or metal sheet piling constructed to surround the area to be occupied by an abutment, pier, retaining wall, or other structure and permit dewatering of the enclosure so that the excavation for the preparation of a foundation and the abutment, pier, or other construction may be produced in the open air. The alignment of the piles may be facilitated by the use of walers, struts, and ties.

**SHEET PILING (Sheeting)** -- A general or collective term used to describe a number of sheet piles taken together to form a crib, cofferdam, bulkhead, etc.

**SHIM** -- A comparatively thin piece of wood, stone, or metal inserted between two elements, pieces, or members to fix their relative position and/or to transmit bearing stress.

**SHOE** -- In general, a pedestal-shaped member at the end of a plate girder or truss functioning to transmit and distribute its loads to a masonry bearing area or to any other supporting area or member.

**SHORE** -- A strut or prop placed in a horizontal, inclined, or vertical position against or beneath a structure or a portion thereof to restrain movement.

**SIDEWALK** -- The portion of the bridge floor area serving pedestrian traffic only and, for safety and convenience to its users, commonly elevated above the portion occupied by vehicles.

**SILT** -- Very finely divided siliceous or other hard and durable rock material derived from its mother rock through attritive or other mechanical action rather than chemical decomposition. In general, its particle size shall be that which will pass a No. 200 sieve.

**SIMPLE SPAN** -- A superstructure span having, at each end, a single unrestraining bearing or support and designed to be unaffected by stress transmission to or from an adjacent span or structure.

**SKEW ANGLE** -- As applied to oblique bridges, the skew angle, angle of skew, or simply skew is the acute angle subtended by a line normal to the longitudinal axis of the structure and a line parallel to or coinciding with the alignment of its end.

**SLAB** -- A thick plate, usually of reinforced concrete, that supports load by flexure. It often is treated as a widened beam.

**SLAB BRIDGE** -- A bridge having a superstructure composed of a reinforced concrete slab constructed either as a single unit or as a series of narrow slabs placed parallel with the roadway alignment and spanning the space between the supporting abutments or other substructure parts. The former is commonly constructed in place, but the latter may be precast.

**SLOPE** -- A term commonly applied to the inclined surface of an excavated cut or an embankment.

**SOFFIT** -- See INTRADOS

**SPALLS** -- Circular or oval depression in concrete caused by a separation of a portion of the surface concrete, revealing a fracture parallel with or slightly inclined to the surface. Usually, part of the rim is perpendicular to the surface. -- The pieces of spalled concrete themselves.

**SPAN** -- This term has various applications depending upon its use whether in design, in field construction, or in its common nontechnical application. When applied to design of a beam, girder, truss, or arch structure, the distance center to center of the end bearings or the distance between the lines of action of the reactions, whether induced by substructure or other supporting members.

**SPECIFICATIONS** -- A detailed enumeration of the chemical and physical properties determining the quality of construction materials together with requirements for handling, shipping, and storage thereof; the conditions governing the loads, load applications, and unit stress considerations of bridge foundation, substructure, and superstructure design; the development of construction details and their applications incident to fabrication, erection, or other construction procedures pertinent to the production of serviceable bridge structures.

**SPLICE** -- This term has two applications depending upon its use whether in design or in shop and field construction. -- When applied to design and the development of construction details, the joining or uniting of elements of a member, parts of a member, or members of a structure to provide desired conditions for the transmittal of stress and the development of rigidity and general strength, fulfilling the service requirements of the member or of the structure of which it is a part. --

When applied to shop and field construction, the complete assemblage of parts used in producing the union of elements of a member or members of a structure.

**SPLICE JOINT** -- A joint in which the elements of a member or the members of a structure are joined by a splice plate or by a part or piece functioning to secure a required amount of strength and stability.

**SPRINGING LINE** -- The line within the face surface of an abutment or pier at which the intrados of an arch takes its beginning or origin.

**STEM** -- The vertical wall portion of an abutment retaining wall or solid pier.

**STIFFENER** -- An angle, tee plate, or other rolled section riveted, bolted, or welded upon the web of a plate girder or other built-up member to transfer stress and to prevent buckling or other deformation.



**STIRRUP** -- In timber and metal bridges, a U-shaped rod, bar, or angle piece providing a stirrup-like support for an element of a member or a member. -- In reinforced concrete bridges, a U-shaped bar placed in beams, slabs, or similar constructions to resist diagonal tension stresses.

**STONE FACING (Stone Veneer, Brick Veneer)** -- A stone or brick surface covering or sheath laid in imitation of stone or brick masonry, but having a depth thickness equal to the width dimension of one stone or brick for stretchers and the length dimension for headers.

**STRINGER** -- A longitudinal beam supporting the bridge deck, and in large bridges or truss bridges, framed into or upon the floor beams.

**STRUCTURAL MEMBERS** -- Basically these are of three types: **Ties** -- pieces subject to axial tension only, **Columns or Struts** -- pieces subject to axial compression only, **Beams** -- pieces transversely loaded and subject to both shear and bending moment.

**STRUCTURAL SHAPES** -- As applied to bridge structures, the various types and forms of rolled iron and steel having flat, round, angle, channel, "I", "H", "Z", and other cross-sectional shapes adapted to the construction of the metal members incorporated in reinforced foundations, substructures and superstructures.

**SUBSTRUCTURE** -- The abutments, piers, grillage, or other constructions built to support the span or spans of a bridge superstructure, whether consisting of beam, girder, truss, trestle, or other type or types of construction.

**SUPERSTRUCTURE** -- The entire portion of a bridge structure that primarily receives and supports highway, railway, canal, or other traffic loads and in turn transfers the reactions resulting therefrom to the bridge substructure. The superstructure may consist of beam, girder, truss, trestle, or other type or types of construction.

**SWAY BRACE** -- 1. A piece bolted or otherwise secured in an inclined position upon the side of a pile or frame bent between the cap and ground surface or the cap and sills, as the case may be, to add rigidity to the assemblage. See BRACING. 2. An inclined member in a tier of bracing forming a part of a timber, metal, or reinforced concrete bent or tower. 3. One of the inclined members of the sway bracing system of a metal girder or truss span. In plate girder construction, the term X-brace is sometimes used.

**TAIL WATER** -- Water ponded below the outlet of a culvert, pipe, or bridge waterway, thereby reducing the amount of flow through the waterway. Tail water is expressed in terms of its depth.

**TEMPORARY BRIDGE** -- A structure built for emergency or interim use to replace a previously existing bridge demolished or rendered unserviceable by flood, fire, wind, or other untoward occurrence, or instead, to supply bridge service required for a relatively short period.

**TENDON** -- A prestressing cable or strand.

**TENSION** -- An axial force or stress caused by equal and opposite forces pulling at the ends of the members.

**THROUGH BRIDGE** -- A bridge having its floor elevation more nearly at the elevation of the bottom than at the top portion of the superstructure, thus providing for the passage of traffic between the supporting parts.

**TIE ROD (Tie Bar)** -- A rod-like or bar-like member in a truss or other frame functioning to transmit tensile stress.

**TOE OF SLOPE** -- The location defined by the intersection of the sloped surface of an approach cut, embankment, causeway, or other sloped area with the natural or an artificial ground surface existing at a lower elevation.

**TRANSVERSE BRACING (Transverse System)** -- The bracing assemblage engaging the columns of trestle and viaduct bents and towers in perpendicular or slightly inclined planes of their sash braces to function in resisting the transverse forces resulting from wind, lateral vibration, and traffic movements tending to produce lateral movement and deformation of the columns united thereby. See BRACING.

**TRESTLE** -- A bridge structure consisting of beam, girder, or truss spans supported upon bents. The bents may be of the piled or of the frame type, composed of timber, reinforced concrete, or metal.

**TRUSS** -- A jointed structure having an open web construction so arranged that the frame is divided into a series of triangular figures, with its component straight members primarily stressed axially. The triangle is the truss element, and each type of truss used in bridge construction in an assemblage of triangles. The connecting pins are assumed to be frictionless.

**TRUSS BRIDGE** -- A bridge having a truss for a superstructure. The ordinary single span rests upon two supports, one at each end, which may be abutments, piers, bents, towers, or combinations thereof. The superstructure span may be divided into three parts: the trusses, the floor system, and the bracing.

**TURNBUCKLE** -- A device used to connect the elements of adjustable rod and bar members. It consists of a forging having nut-like end portions, right- and left-hand threaded and integrally connected by two bars upon its opposite sides, thus providing an intervening open space through which a lever may be inserted to adjust the tension in the member.

**U-BOLT** -- A bar, either round or square, bent in the shape of the letter U and fitted with threads and nuts at its ends.

**VIADUCT** -- A bridge structure consisting of beam, girder, truss, or arch span supported upon abutments with towers or alternate towers and bents, with a series of piers (cylindrical, dumbbell, rectangular, or other types), or with any combination of these types of supporting parts.

**WASHER** -- A small metal disc having a hole in its center to engage a bolt or a rivet. It may be used beneath the nut or the head of a bolt or as a separator between elements of a member or the members of a structure.

**WATER TABLE** -- The upper limit or elevation of ground water saturating a portion of a soil mass.

**WATERWAY** -- The available width for the passage of stream, tidal, or other water beneath a bridge, if unobstructed by natural formations or by artificial constructions beneath or closely adjacent to the structure. For a multiple span bridge, the available width is the total of the unobstructed waterway lengths of the spans.

**WEARING SURFACE (Wearing Course)** -- The surface portion of a roadway area that is in direct contact with the means of transport and is, therefore, primarily subject to the abrading, crushing, or other disintegrating effect produced by hammering, rolling, sliding, or other physical action tending to induce attrition thereof.

**WEB** -- The portion of a beam, girder, or truss, located between and connected to the flanges or the chords. It serves mainly to resist shear stresses. The stem of a dumbbell or solid wall type pier.

**WEEP HOLE (Weep Pipe)** -- An open hole or an embedded pipe in a masonry retaining wall, abutment, arch, or other portion of a masonry structure to provide means of drainage for the embankment, causeway, spandrel backfill, or retained soil wherein water may accumulate.

**WELD** -- The process of uniting portions of one or more pieces, the elements of a member, or the members of a structure in an intimate and permanent position or status (1) by the application of pressure induced by the blow of a hammer or by a pressure machine, the portions to be united having been previously heated to a so-called welding temperature and the junction areas cleaned and purified by the application of fluxing material; (2) by the use of a high temperature flame to preheat the metal adjacent to the weld location and, when it has attained a molten temperature, to add molten weld metal, in conjunction with fluxing material, in sufficient quantity to produce a fully filled joint when cooled; or (3) by the use of the electric arc to obtain a molten temperature in the metal closely adjacent to the weld location and to supply in the arc stream molten filler metal and fluxing material requisite to produce by coalescence of the structure and electrode metals a fully filled joint. -- The joint produced by the application of a welding process.

**WELDED BRIDGE (Welded Structure)** -- A structure wherein the metal elements composing its members, and the joints whereby these members are combined into the structure frame, are united by welds.

**WHEEL CONCENTRATION (Wheel Load)** -- The load carried by and transmitted to the supporting structure by one wheel. This concentration may involve the wheel of a traffic vehicle, a movable bridge, or other motive equipment or device.

**WHEEL GUARD (Filloe Guard)** -- A timber piece placed longitudinally along the side limit of the roadway to guide the movements of vehicle wheels and safeguard the bridge trusses, railings, and other constructions existing outside the roadway limit from collision with vehicles and their loads.

**WIDE FLANGE (Carnegie Beam)** -- A rolled member having an H-shaped cross section, differentiated from an I-beam in that the flanges are wider and the web thinner.

**WIND BRACING** -- The bracing systems in girder and truss spans and in towers and bents that function to resist the stresses induced by wind forces.

**WING WALL** -- The retaining wall extension of an abutment intended to restrain and hold in place the side slope material of an approach causeway or embankment. When flared at an angle with the breast wall, it serves also to deflect stream water and floating debris into the waterway of the bridge and thus protects the approach embankment against erosion.

**TENDON** -- A prestressing cable or strand.

**TENSION** -- An axial force or stress caused by equal and opposite forces pulling at the ends of the members.

**THROUGH BRIDGE** -- A bridge having its floor elevation more nearly at the elevation of the bottom than at the top portion of the superstructure, thus providing for the passage of traffic between the supporting parts.

**TIE ROD (Tie Bar)** -- A rod-like or bar-like member in a truss or other frame functioning to transmit tensile stress.

**TOE OF SLOPE** -- The location defined by the intersection of the sloped surface of an approach cut, embankment, causeway, or other sloped area with the natural or an artificial ground surface existing at a lower elevation.

**TRANSVERSE BRACING (Transverse System)** -- The bracing assemblage engaging the columns of trestle and viaduct bents and towers in perpendicular or slightly inclined planes of their sash braces to function in resisting the transverse forces resulting from wind, lateral vibration, and traffic movements tending to produce lateral movement and deformation of the columns united thereby. See BRACING.

**TRESTLE** -- A bridge structure consisting of beam, girder, or truss spans supported upon bents. The bents may be of the piled or of the frame type, composed of timber, reinforced concrete, or metal.

**TRUSS** -- A jointed structure having an open web construction so arranged that the frame is divided into a series of triangular figures, with its component straight members primarily stressed axially. The triangle is the truss element, and each type of truss used in bridge construction in an assemblage of triangles. The connecting pins are assumed to be frictionless.

**TRUSS BRIDGE** -- A bridge having a truss for a superstructure. The ordinary single span rests upon two supports, one at each end, which may be abutments, piers, bents, towers, or combinations thereof. The superstructure span may be divided into three parts: the trusses, the floor system, and the bracing.

**TURNBUCKLE** -- A device used to connect the elements of adjustable rod and bar members. It consists of a forging having nut-like end portions, right- and left-hand threaded and integrally connected by two bars upon its opposite sides, thus providing an intervening open space through which a lever may be inserted to adjust the tension in the member.

**U-BOLT** -- A bar, either round or square, bent in the shape of the letter U and fitted with threads and nuts at its ends.

**VIADUCT** -- A bridge structure consisting of beam, girder, truss, or arch span supported upon abutments with towers or alternate towers and bents, with a series of piers (cylindrical, dumbbell, rectangular, or other types), or with any combination of these types of supporting parts.

**WASHER** -- A small metal disc having a hole in its center to engage a bolt or a rivet. It may be used beneath the nut or the head of a bolt or as a separator between elements of a member or the members of a structure.

**WATER TABLE** -- The upper limit or elevation of ground water saturating a portion of a soil mass.

**WATERWAY** -- The available width for the passage of stream, tidal, or other water beneath a bridge, if unobstructed by natural formations or by artificial constructions beneath or closely adjacent to the structure. For a multiple span bridge, the available width is the total of the unobstructed waterway lengths of the spans.

**WEARING SURFACE (Wearing Course)** -- The surface portion of a roadway area that is in direct contact with the means of transport and is, therefore, primarily subject to the abrading, crushing, or other disintegrating effect produced by hammering, rolling, sliding, or other physical action tending to induce attrition thereof.

**WEB** -- The portion of a beam, girder, or truss, located between and connected to the flanges or the chords. It serves mainly to resist shear stresses. The stem of a dumbbell or solid wall type pier.

**WEEP HOLE (Weep Pipe)** -- An open hole or an embedded pipe in a masonry retaining wall, abutment, arch, or other portion of a masonry structure to provide means of drainage for the embankment, causeway, spandrel backfill, or retained soil wherein water may accumulate.

**WELD** -- The process of uniting portions of one or more pieces, the elements of a member, or the members of a structure in an intimate and permanent position or status (1) by the application of pressure induced by the blow of a hammer or by a pressure machine, the portions to be united having been previously heated to a so-called welding temperature and the junction areas cleaned and purified by the application of fluxing material; (2) by the use of a high temperature flame to preheat the metal adjacent to the weld location and, when it has attained a molten temperature, to add molten weld metal, in conjunction with fluxing material, in sufficient quantity to produce a fully filled joint when cooled; or (3) by the use of the electric arc to obtain a molten temperature in the metal closely adjacent to the weld location and to supply in the arc stream molten filler metal and fluxing material requisite to produce by coalescence of the structure and electrode metals a fully filled joint. -- The joint produced by the application of a welding process.

**WELDED BRIDGE (Welded Structure)** -- A structure wherein the metal elements composing its members, and the joints whereby these members are combined into the structure frame, are united by welds.

**WHEEL CONCENTRATION (Wheel Load)** -- The load carried by and transmitted to the supporting structure by one wheel. This concentration may involve the wheel of a traffic vehicle, a movable bridge, or other motive equipment or device.

**WHEEL GUARD (Filloe Guard)** -- A timber piece placed longitudinally along the side limit of the roadway to guide the movements of vehicle wheels and safeguard the bridge trusses, railings, and other constructions existing outside the roadway limit from collision with vehicles and their loads.

**WIDE FLANGE (Carnegie Beam)** -- A rolled member having an H-shaped cross section, differentiated from an I-beam in that the flanges are wider and the web thinner.

**WIND BRACING** -- The bracing systems in girder and truss spans and in towers and bents that function to resist the stresses induced by wind forces.

**WING WALL** -- The retaining wall extension of an abutment intended to restrain and hold in place the side slope material of an approach causeway or embankment. When flared at an angle with the breast wall, it serves also to deflect stream water and floating debris into the waterway of the bridge and thus protects the approach embankment against erosion.

**APPENDIX**

**BRIDGE INSPECTORS TRAINING PROGRAM**  
**Kentucky Transportation Cabinet**



## BRIDGE INSPECTORS TRAINING PROGRAM

### Work Booklet

Section 2: Fundamentals of Bridge Inspection

Topic 8: Structure Inventory and Appraisal Report

Method of Instruction: Lecture/Disucssion

Location: Classroom

Time: 4 Hours

#### SCOPE:

This session will be concerned with providing each student with the basic background necessary for proper completion and submission of the Structure Inventory and Appraisal Report as required by the Kentucky Department of Transportation and the FHWA.

#### OBJECTIVES:

1. To provide you with a brief review of the purpose and scope the Structure Inventory and Appraisal Report (S.I. & A.).
2. To provide you with the correlation between the standard forms and the S.I. & A. Report.
3. To provide you with a basic understanding of the S.I. & A. Report and its major components.
4. To provide you with an item-by-item review of the S.I. & A. Report.

#### STUDY ASSIGNMENT:

1. Review all training materials for this session as required for basic understanding.

#### INTRODUCTION:

During this session we will be discussing the scope and purpose of the Structure Inventory and Appraisal Report, commonly called the "S.I. & A. Report," which you will be required to complete for each bridge you inspect. We will briefly review some of the activities at both federal and state levels which lead to the bridge inspection and reporting requirements as they now exist.

By the end of the session you should have a basic understanding of the S.I. & A. Report and what is required for its preparation. This session is designed only to review the S.I. & A. Report and the various forms and reports which are used to properly prepare the information for submission to the Bridge Section in the Division of Maintenance. This session is not designed to address detailed field problems or specific situations which you may encounter. These questions should be discussed with the Division of Maintenance. Personnel in that office can more effectively assist you with your questions and particular needs.

One objective of the Kentucky Department of Transportation is to maintain an accurate inventory of bridges as required by federal laws. If you encounter problems or situations which, AFTER FULL INVESTIGATION ON YOUR PART, you cannot effectively answer, then do not hesitate to call the Division of Maintenance, Bridge Section, personnel for assistance.

#### PRESENTATION:

1. PURPOSE AND SCOPE

On December 15, 1967, the bridge between Point Pleasant, West

Virginia, and Kanauga, Ohio, (known as the Silver Bridge) suddenly collapsed, resulting in the deaths of 46 people and serious injuries to nine others.

While the existing state-of-the-art of bridge inspection could not have detected the deficiencies in the Silver Bridge, the catastrophe highlighted the need for the development of new inspection equipment, techniques, reporting procedures, and bridge inventory systems and procedures. Accordingly, the United States Congress added a section to the Federal Aid Highway Act of 1968 requiring the Secretary of Transportation to establish a national bridge inspection standard and to develop a program to train bridge inspectors. As a result, federal regulations now require all bridge structures located on federal routes to be inspected at least once every two years by a professional engineer or personnel having completed specialized training in the area of maintenance inspection of bridges.

The Federal Highway Administration (FHWA) subsequently developed the "Bridge Inspector's Training Manual" as a guide to be used in the preparation of the specialized training programs.

Concurrently, the American Association of State Highway and Transportation Officials (AASHTO) developed the "Manual for Maintenance and Inspection of Bridges" which addressed itself to the development of standards and uniformity in procedures and policies relating to bridge inspections. AASHTO has also developed the "AASHTO Manual for Bridge Maintenance (1976)." The purpose of this manual is to provide guidelines for the proper maintenance of highway bridges.

2. In March of 1972, the Federal Highway Administration (FHWA) issued a notice that required all bridges carrying or going over Federal Aid highways to be inventoried; and, in July of 1972, issued the "Recording and Coding

Guide for the Structure Inventory and Appraisal of the Nation's Bridges."

In April, 1977, the FHWA issued a commentary on the Recording and Coding Guide. In January, 1979, a new Recording and Coding Guide was issued. This new edition essentially incorporated the Commentary into the language of the main document. Also, the KDOT Division of Maintenance, Bridge Section, has developed an "Additions and Interpretations Commentary" to the new FHWA Coding Guide.

In addition to federal requirements, Kentucky has (March, 1977) established rules and regulations (OFFICIAL ORDER 82930) governing the maintenance and inspection of bridges. Chapter 71-05, Section 0300, pertains to bridge inspection requirements.

#### 71-05.0300 INSPECTION

*.0310 All bridges shall be inspected in compliance with the "National Bridge Inspection Standards." Each bridge is to be inspected at a regular interval, not to exceed two (2) years, by a Bridge Inspection Team with an individual in charge of the team that possesses the following minimum requirements:*

- (1) Be a Registered Professional Engineer, or*
- (2) Be qualified for registration as a Professional Engineer under State Laws, or*
- (3) Have a minimum of five years experience in bridge inspection assignments in a responsible capacity and have completed a comprehensive training course based on the "Bridge Inspector's Training Manual."*

*.0320 Interim Inspections - All bridges maintained jointly with adjoining States shall be inspected annually with representatives of the adjoining State in accordance with present agreements. All bridges located on routes which have been approved for an "Overweight Haul Permit" shall be inspected at a regular interval, not to exceed one (1) year. In case of a major flood, inspections of flooded bridges will be made immediately after the water recedes, giving special attention to the substructure.*

*.0330 Report Forms - Form TD 71-104, Inspection of Drainage Structures (Exhibit 71-20) shall be completed for each inspection and submitted to the Central Office Division of Maintenance. Form TD 66-201-1, Structural Inventory and*

*Appraisal Sheet (Exhibit 71-11) shall be completed and submitted to the Central Office Division of Maintenance within 90 days after the acceptance of a bridge for maintenance or a major renovation of a bridge.*

The Kentucky Department of Transportation has spent considerable effort in the design and implementation of procedures capable of collecting the data required for FHWA regarding bridge inspection. To accomplish this task, the department is utilizing existing bridge inventory and appraisal systems in conjunction with existing computer programs.

By approaching the bridge inspection task in this manner, the Kentucky Department of Transportation has developed a fully compatible system capable of meeting the requirements of the FHWA.

### 3. STANDARD FORMS

Included in your work booklet are a number of "Standard Forms" which have been prepared by the Department of Transportation to assist you in conducting thorough bridge inspections. The use of these reports is optional and the specific content and detail of each inspection report may differ from bridge to bridge. These forms are structured in such a manner as to provide each inspector with a worksheet which will assist in both inspection of the bridge and completion of the S.I. & A. Report.

As you will note, a portion of the forms allows the inspector to document a number of general items related to each bridge. The majority of these items need only be documented for the initial inspection of the bridge, as they normally will not change once in the permanent file.

For each item of information requested on the form is a number which corresponds to specific item numbers required on the S.I. & A. Report for a bridge.

A similar approach is used for each item required to be rated for the S.I. & A. Report, such as the superstructure, the substructure, channel and channel protection, culverts, and approach roadway alignment. In short, the standard forms not only help you to prepare and document each bridge inspection, they assist you in filling out your S.I. & A. Reports. Once again, the use of these forms is optional.

4. In January of 1979, FHWA prepared and issued the "Recording and Coding Guide for the Structure Inventory and Appraisal of the Nation's Bridges." In the guide, FHWA presented the Structure Inventory and Appraisal Sheet which was intended to be a record of key items of information about each individual structure inspected. The data collected was designed to meet the needs of the Office of Emergency Preparedness (OEP), the Department of Defense (DOD), and the Federal Highway Administration. The information gathered via the S.I. & A. Report will assist these agencies in carrying out their responsibilities relating to:

- Highway Safety
- National Emergencies
- Disaster Relief
- Defense Activities
- Facility Repair and Replacement

The specific categories of information of interest to FHWA, as shown on this copy of their form, include:

a. Identification: This general category is designed to record some basic data for specific identification of each structure under consideration. Items identified for completion include: State, Highway District,

Structure Number, Road Section Number, Defense Milepoint, Latitude and Longitude.

b. Classification: This category is provided to classify each bridge according to what roadway system the structure is included in (i.e., is it on a federal highway or is it on a local highway?). Information is also collected to identify what functional system the structure is on; that is: what is the primary function of the roadway? Examples would be interstate roadways versus minor arterial roadways.

c. Structural Data: This section on the S.I. & A. Sheet is designed to provide the users with the basic structural data about each structure. This would include items such as number of lanes, design load, approach roadway width, type of structure, structure length, and various clearances.

The three general categories - Identification, Classification and Structural Data - become the basic information needed for the Structure Inventory. Much of this data will be prepared for the first inspection for a particular structure and any subsequent inspections will usually result in only minor modification. The first inspection report for each structure will be the most time-consuming because of the need to locate all the required data for inventory purposes.

A complete S.I. & A. form is filled out only once on each bridge. This is at the time of the initial inspection. On subsequent inspections, an abbreviated S.I. & A. update form is used unless a complete new S.I. & A. form is requested by the Division of Maintenance, Bridge Section.

No documents of an inspection should be destroyed as long as the specific structure is still existing.

d. Condition: In this category, data is collected regarding the actual condition of various portions of the structure. It is here that many of the results of the inspection are recorded.

e. Appraisal: The intent of this category is to evaluate a bridge in relation to the highway system and functional classification of which it is a part. The structure is compared to current standards in effect in the state for construction of new structures. In other words, how does the bridge shape up compared to today's standards?

For bridges on the federal system and under the jurisdiction of the Commonwealth of Kentucky, AASHTO Standards are followed. The Kentucky DOT has also prepared a number of specific guidelines designed to assist each inspector to determine the appropriate appraisal ratings based on various pre-determined standards. The Geometric Design Criteria is the standard used to aid in the determination of adequate deck width.

f. Proposed Improvements: This category is provided to identify, based on the inspection results, the type and scope of improvements for each structure. This is to aid in the estimation on bridge repair and replacement needs in the state.

g. Cost of Improvements: This category is identified in conjunction with the Proposed Improvements category to allow for the planning of appropriate funding to effect the improvements recommended.

The last portion of the S.I. & A. Sheet we just discussed - Condition, Appraisal, Proposed Improvements and Cost of Improvements - will constitute the major portion of each bridge inspection report subsequent to the initial inspection. Once the inventory of bridges has been established, it becomes a



process of updating the inventory information as required and inserting the current condition and appraisal ratings determined as a result of each inspection. The important point to remember here is that your inspection report is the focal point for communicating the condition of Kentucky's bridges to Washington. This information is subsequently used to determine the amount of bridge repair and replacement funds required.

#### 5. S.I. & A. ITEM ANALYSIS

As we discuss each item in detail, you should keep both the FHWA Coding Guide and the Kentucky Interpretations and Additions handy for reference purposes. We also will use the results of a simulated bridge inspection to illustrate how the coding procedure works. Using the Coding Guide and the Commentary, you will notice that there are a number of items on a page, each of which is followed by a brief discussion of the coding procedure. To the far right of each item you will also notice the number of positions, or digits, is specified. For example, Item 4 - City/Town Code requires a 4-digit code be used to identify each location. The code for Liberty City is 1165. The "1165" would then be entered as required in the appropriate location on the S.I. & A. form provided by the Department.

In some instances, you will need to left or right justify your codes. This simply means that, to right justify a code, the number or item of information should be placed as far to the right as possible. To left justify a code, begin the code as far to the left as possible.

#### 6. PROJECT NUMBER

On the top line and in the center of the Kentucky S.I. & A. form is a space for a project number. You may not have to fill this in. This will be assigned by the Bridge Section, Division of Maintenance, if a number does not always exist.

2-8-9

## 7. INVENTORY DATA

As we proceed to discuss each item, you may wish to make note on an actual S.I. & A. Coding Sheet of the correct response for each item.

### Item 1 - State Code: 3 Digits

Each state is assigned a code for identification purposes. The first two digits are the Federal Information Processing Standards Code (FIPS) for the state and the third digit is the FHWA region code. The code for Kentucky is 214 and should be coded in the spaces provided. You must use the assigned code of 214 or the data will be rejected.

Code: 2 1 4

### Item 2 - State Highway Department District: 2 Digits

The highway district (as defined by Kentucky DOT) in which the bridge structure is located is coded with a 2-digit number. The bridge we will be using as an example is in Barren County, which is in District 3.

This information can be located by referring to the "Counties by Highway Districts" handout. The code that will be accepted for this item must be numeric and filled with leading zeroes. You should right justify the entry.

Code: 0 3

### Item 3 - County: 3 Digits

Each County is identified and coded based on the U.S. Census of Population and Housing - 1970. This data has been provided as a handout by the Kentucky DOT for your use in this program. For your information, the way this code is determined is to multiply the county number by two and subtract one. As an example, Barren County is County Number 5. The data entered for this code item must be numeric. All zeroes is not acceptable and will be rejected

in the edit routine..

The appropriate code for Barren County is "009".

Code: 0 0 9

Item 4 - City/Town Code: 4 Digits

Each city and town is identified with a code number provided in the "Kentucky City Codes" handout. If a structure is located in an area that does not have an assigned city/town code, it would be coded with all zeroes. All entries must be numeric. To illustrate, a bridge in Glasgow would be coded "0795". Our example would be coded "0000" because the bridge is located outside of an area having an assigned code.

Code: 0 0 0 0

-- Item 5 - Inventory Route: 9 Digits

When completing data for the S.I. & A. Report, it is important to be sure that all the information coded is based on whether you are inventorying the route or the structure.

The first position for this item will indicate if the route is carried by the structure or goes under it. Page 3 of the FHWA Coding Guide contains this information. For our bridge, the correct coding for the first position is "1" and this condition will be true of most of the bridges inventoried.

The second position identifies the type of highway carried by the structure. The appropriate codes for this position, as shown on page 3 of the FHWA Coding Guide, are 1 through 8. All other codes will produce an error. In the case of our bridge, this item is coded "3" because it is a state numbered highway.

The third position in the 9-digit code is used to identify the highway

according to your coding guide. Our bridge would be coded "1" for main line structure.

In the next five positions, you must code the route number of the roadway. If no route number exists, code all zeroes. Right justify all codes. For example, to code Route 541, you would code "00541." To code our bridge, you would code "00249" because that is the state number. Other examples are provided in the guide. If these positions are blank, it will cause an error to occur. If a letter (alpha character) appears in the route number, it should not be coded as part of these five positions. You should drop the letter and add leading zeroes to right justify the number. For example, "295A" would be coded as "00295" in the 5 positions.

The last portion indicates the directional suffix added to a route number. This should not be confused with a directional marker placed below a sign to indicate the direction of travel. To distinguish the difference, you should consult a Kentucky transportation map or route log.

The main route over the bridge (level one) and the main route under the bridge (level two) are to be listed and coded. In addition, the main route under the bridge is to have Items 5, 6, 7, 9 through 20, 24, 25, 26, 29, 30 and 47 recorded and coded as level two. The route number should be right justified in the five appropriate positions. (See example below) This is to be numbers only. No alpha characters.

**Examples:**

|            |                      |                |
|------------|----------------------|----------------|
| US 41A on  | record 1 2 2 00041 0 | code 122000410 |
| US 127B on | 1 2 3 00127 0        | 123001270      |
| US 23S on  | 1 2 4 00023 0        | 124000230      |
| US 31ES on | 1 2 6 00031 2        | 126000312      |
| US 27C on  | 1 2 7 00027 0        | 127000270      |

Our bridge would be coded as "0" because it has no directional suffix.

The entire code for this number would be as follows:

Code: 1 3 1 0 0 2 4 9 0

Item 6 - Features Intersected (Reference Point): 25 Positions

In this section, you should make note of the features which intersect with the facility, whether they are over or under the structure. If the feature intersected is a highway, you should note this in the left-most position. Attempt to be as clear as possible in your description. If you run out of space, use meaningful abbreviations. The last position is reserved to indicate whether or not the structure is a critical structure for defense and other purposes. This information is considered to be confidential in that it could be detrimental to the security of critical highway facilities and, therefore, it should not be released indiscriminantly as public information. The Bridge Section, Division of Maintenance, will code this portion of the item for you. Do not code the last position of this item.

To code our bridge we have used the following information:

Code: P E T E R S \_ C R E E K \_ \_ \_ \_ \_

Item 7 - Facility Carried by Structure: 18 Positions

The facility carried by the structure should be recorded. In our case, we have coded this information as follows:

Code: K \_ Y \_ \_ 2 4 9 \_ \_ \_ \_ \_

Item 8 - Structure Number: 15 Positions

The structure number is a unique number for each bridge within the state. The number is made up of 3 sections separated by asterisks. The first section consists of three positions and is the county number. The second section consists of four positions and is the route number which may include alpha characters. The last section consists of six positions; the

first position is a "B", in the example. The next four positions indicate the bridge number assigned for that county right justified. The last position is to be blank or a "P", when so coded in Item 13.

Example:

115\*9002\*B0011P

The bridge number should be right justified for consistency. The appropriate structure number for our bridge is "005\*0249\*B0023."

Code: 0 0 5 \* 0 2 4 9 \* B 0 0 2 3 \_

Item 9 - Location: 25 Positions

This item is provided for a narrative description of the location of the structure. Simply provide a description of the location. Left justify the data. For our bridge, this would be:

Code: 1 . 1 \_ M I \_ S O U T H \_ O F \_ K Y \_ 9 2 1 \_ \_ \_

Item 10 - Inventory Route, Minimum Vertical Clearance: 4 Digits

The information to be recorded and coded for this item is the minimum vertical clearance over the roadway. The vertical clearance must be measured for a 10' wide section of either the pavement or travelled portion of the roadway, where the clearance is the highest. Record this vertical clearance for the 10' width regardless of the direction of travel. It should be noted where this 10' lane falls so that this data can be checked on recurring inspections. If the vertical clearance is unlimited, code the item "9999". If an obstruction exists, physically measure the vertical clearance. The distance measured should be recorded in feet and inches, using zeroes to fill in the unused positions. For example, a vertical clearance of 16' 2" should be coded as "1602". In the case of our structure, the code would be:

Code: 9 9 9 9

Item 11 - Milepoint: 5 Digits

The milepoint will refer to the beginning of the bridge in the direction of increasing milepoints. Record a 6-digit number to represent the milepoint to 1000th of a mile. Code a 5-digit number to represent the milepoint to 100th of a mile. Code "00001" if a milepoint location cannot be determined or is not appropriate. Code "00002" if the milepoint location of the structure is at the beginning of the route mileage, rather than "00000". The structure we are using as an example is located at Milepoint 002.820 and would be coded as follows:

Code: 0 0 2 8 2

Item 12 - Defense Road Section Number: 5 Positions

If the bridge is on a designated defense highway, the appropriate section number must be obtained from DOT records and coded. When coding this item, be careful to code only the first four positions, right justifying the data. The fifth position should be used only as indicated in the guide. Examples are provided in the guide for your reference. Our bridge is not a defense highway, so it would be coded with the appropriate number of "00000". If you do not code this item, it will show as an error.

Code: 0 0 0 0 0

Item 13 - Bridge Description: 2 Positions

The coding for this item is primarily for defense purposes; however, all the structures in the inventory must be coded. Utilize the three available codes or leave blank. If two codes apply, they must be in alphabetical order. This item is discussed in more detail on page 7 of the FHWA Coding Guide. For our bridge none of the codes apply, so it would be left blank.

Code:

Item 14 - Defense Milepoint: 4 Digits

The distance that the structure is from the beginning of the applicable defense road section must be coded to the nearest 100th of a mile. If the defense milepoint system does not apply, then the item must be coded with all zeroes or left blank. Use leading zeroes if needed to utilize all the positions. Since our bridge is not on a defense highway, our code would be "0000".

Code: 0 0 0 0

Item 15 - Defense Section Length: 3 Digits

The length of the defense section should be coded to the nearest 10th of a mile. If the item is not applicable, code all zeroes. Leading zeroes should also be used if needed. For example, if the defense section length is 2.3 miles long, the code would be "023". For our bridge our code is "000" because it is not on a defense highway.

Code: 0 0 0

Item 16 - Latitude: 5 Digits

For bridges on defense highways, the latitude should be recorded in degrees, minutes and tenths of minutes. An example is shown on page 8 in the guide of how to proceed with this item. This information will be made available through the Planning Department. If not applicable, code all zeroes. If a bridge is located at latitude 27<sup>o</sup>43.0", our code would be "27430". Our bridge is coded "00000" since it is not on a defense highway.

Code: 0 0 0 0 0

Item 17 - Longitude: 6 Digits

This item should be coded in a similar fashion as the data for Item 16. The edit programs are structured in such a way that an error will show if you happen to switch the latitude and longitude; so be careful when



completing this item. If the longitude for a bridge is 82<sup>0</sup>41.7", our code would be "082417". Our bridge is coded "000000".

Code: 0 0 0 0 0 0

Item 18 - Physical Vulnerability: 1 Digit

The physical vulnerability should be determined for all structures by coding the basic construction type of bridge utilized. The code possibilities are shown on page 9 in the guide and this item must be numeric. Arch culverts are to be coded "6" and low water fords are to be coded "0". Our bridge is a concrete girder bridge, so it would be coded as a "2".

Code: 2

Item 19 - Bypass, Detour Length: 2 Digits

The intent of this item is to indicate whether or not the structure may be bypassed in case it becomes non-operational. To code this item according to the directions stated in the guide, be careful to examine the drawing closely. The bypassed length is shown as the added distance that would have to be travelled to return to the route. If the bypass length is greater than 99 miles, code "99". If the structure is not bypassable, code "99" also. All detours should be made on routes of equal road classification. For our structure there is no ground level bypass at the site, so the alternative is a 5 mile detour. Code "05" for this item.

Code: 0 5

Item 20 - Toll: 1 Digit

This item is used to determine whether or not there is a toll for using the structure, either directly or indirectly. Four options are possible for this item. A code of "1" indicates a toll bridge. This is used when tolls are paid specifically for the structure. A code of "2" indicates

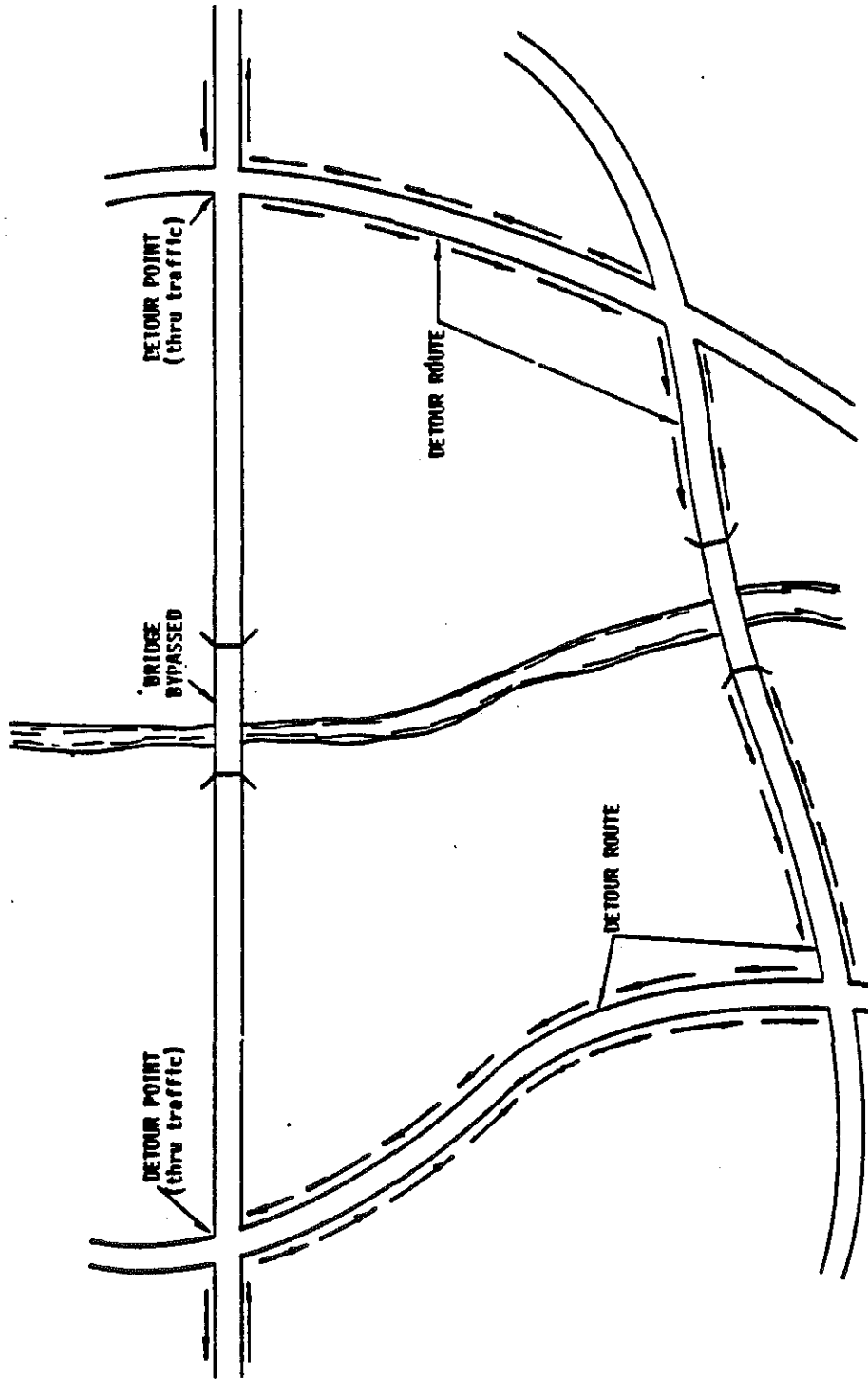

LENGTH OF ROUTE BETWEEN DETOUR POINTS = 10.3 MILES  
 LENGTH OF DETOUR ROUTE WITH THE BRIDGE BYPASSED BETWEEN DETOUR POINTS = 19.6 MILES  
 BYPASS DETOUR LENGTH = 19.6 - 10.3 = 9.3 MILES. (CODE 09 MILES)

a toll road. This is where tolls are paid for use of both the highway and the structure. A toll road is also open to both trucks and cars. A code of "3" indicates a free road and highway. A code of "4" indicates a toll parkway. This is where a toll is paid for use of both the bridge and the road; however, trucks are not permitted. The appropriate code for our structure is "3".

Code: 3

Item 21 - Custodian: 1 Digit

The custodian of the structure is shown on this item. In the absence of a clear designation, the custodian will be the agency responsible for maintaining the structure. The codes shown on page 10 in the guide should be used to represent the type of agency that is the custodian. For our structure, a code of "1" is appropriate.

Code: 1

Item 22 - Owner: 1 Digit

The same codes used in Item 21 should be used to indicate who the owner is. In the case of our bridge, this would also be coded as a "1".

Code: 1

Item 23 - Federal Aid Project Number: 7 Digits

If federal funds have been used for construction or reconstruction of the structure, the Federal Aid project number of the most recent project should be recorded. Federal Aid Project Numbers may be located on the plans for the structure or may be found by referring to the maintenance card files. If the number is not known, or if it does not apply, code all zeroes.

Code: 0 0 0 0 0 0 0

Item 24 - Federal Aid System: 2 Digits

Code the item according to the alternatives shown in the coding

guide. Valid codes for this item are "01" through "04", "05", "07", "09" through "12" and "14". The code for our structure would be "05" for "FA Secondary Rural."

Code: 0 5

Item 25 - Administrative Jurisdiction: 1 Digit

This item should be coded using the appropriate codes in the guide.

The only acceptable codes for this item are "1" through "4". Since our bridge is under the administrative jurisdiction of the state, it would be coded "1".

Code: 1

Item 26 - Functional Classification: 2 Digits

The functional classification assigned for the route being inventoried should be coded for this item. The codes are shown on page 11 of the guide. For example, to code an interstate road in an urban community of 25-50 thousand in population, you would code "21". The functional classification categories are prepared by the Planning Department and are available in each District Office. In the case of our bridge, it is a major rural road; therefore, it would be coded "04". Use code "02", "Other Principal Arterial", for parkways.

Code: 0 4

Item 27 - Year Built: 4 Digits

For this item the year the structure was built is coded in the first two positions. The next two positions are used to indicate the latest year of reconstruction, if appropriate. To illustrate, a bridge built in 1920, but reconstructed in 1972, would be coded as "2072" by using the last two digits of each year. Other examples are presented on page 11 in the guide. If the year built is unknown, provide a best estimate. (The year of construction can usually be obtained reasonably close from a long-time resident of the community or by relating to a bridge with a known date of construction.)

The bridge we are using as an example was built in 1965, so it would be coded "6500".

Code: 6 5 0 0

Item 28 - Lanes on and Under the Structure: 4 Digits

Code the number of through lanes being carried by the structure as a 2-digit number. Also, code the total number of through lanes being crossed over by the structure as a 2-digit number. This will be a 4-digit field consisting of two subfields containing the two values. The codes should be right justified with leading zeroes in each of the subfields. Highway lanes only are to be considered.

For example, a two-lane structure carrying traffic over a four-lane interstate would be coded as "0204". Fill all spaces in with leading zeroes if needed. Our bridge carries 2 lanes and does not have any lanes under it.

Code: 0 2 0 0

Item 29 - Average Daily Traffic: 6 Digits

Code a 6-digit number that shows the average daily traffic volume for the route identified in Item 5. Data is available for many roads from the DOT Planning Department. If the data is not available, then an approximation must be made and coded. The code must be greater than zero or an error will occur. The average daily traffic for our bridge was recorded at 356 in 1968. It would be coded as "000356".

Code: 0 0 0 3 5 6

Item 30 - Year of Average Daily Traffic: 2 Digits

Record the year in which the average daily traffic estimate was taken. Code only the last two digits of the year taken. The code for our bridge would be "68".

Code: 6 8

Item 31 - Design Load: 1 Digit

Use the codes outlined in the coding guide for the appropriate item.

If the original design specifications are not available from existing records, use the judgement of a professional engineer as appropriate. If you have exhausted all possibilities to obtain a design loading, then code "0" for unknown. The design load for the bridge we are using is HS20, which would be coded as a "5".

Code: 5

Item 32 - Approach Roadway Width: 3 Digits

Code, to the nearest foot, a 3-digit number that represents the normal width of the roadway approaching the structure. This would include the widths of the shoulders.

Several examples are provided in the guide to illustrate how this can be accomplished.

For our bridge, the approach roadway, including shoulders, measured 21'8". The code for this would be "021". You will notice that we have rounded the dimension down to avoid overstating existing conditions.

Code: 0 2 1

Item 33 - Bridge Median: 1 Digit

Indicate with the 1-digit codes shown on page 13 in the guide if the median is non-existent, opened or closed. The median is closed when the area between the two roadways at the structure is bridged over. The only acceptable codes for this item are "0", "1" and "2". Our bridge would be coded with "0", as it has no median.

Code: 0

Item 34 - Skew: 2 Digits

The skew of the structure refers to the acute angle formed between

2-8-22

the centerline of a pier and a line normal to the centerline of the roadway. It is measured in degrees and can normally be found on the plans for the structure, or it can usually be estimated.

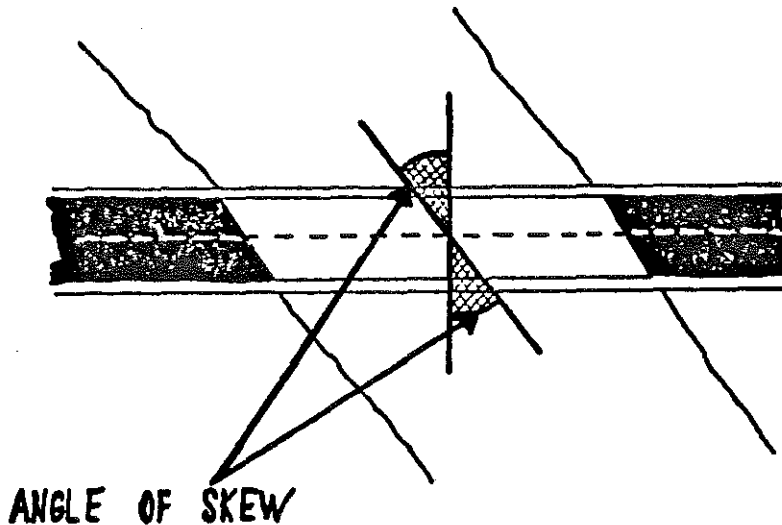

Code the angle to the nearest degree. Our structure has a skew angle of  $30^{\circ}$  and would be coded as "30".

Code: 30

Item 35 - Structure Flared: 1 Digit

The appropriate code should be entered to indicate if the width of the structure varies. Minor variances should be ignored. Code "1" for variances, "0" for no variances. The appropriate code for our structure is "0".

Code: 0

Item 36 - Traffic Safety Features: 4 Digits

Each bridge inspection should include a review of the safety features of a bridge. This review is conducted by examining the four features identified in the guide for each structure. The existing features should then be compared to current standards for design of the feature. A subsequent session of this

program will be concerned with how to approach the analysis of this item. However, professional judgement is also an important element for rating the safety features. Ratings for state inspected bridges will be based on AASHTO and KDOT guidelines.

For our bridge, the ratings assigned were 1, 0, 0, and 0, where "1" says the feature meets currently acceptable standards and "0" says the current standards would not be met.

Code: 1 0 0 0

Item 37 - Blank - Not Used

Item 38 - Navigation Control: 1 Digit

For this item, indicate whether or not navigation control exists.

The determination of whether or not a water course is navigable is made by the U.S. Coast Guard or the U.S. Army Corps of Engineers, whichever is applicable. However, you can usually identify a lighting system for watercraft passage under the main span. Another source would be a publication of the U.S. Coast Guard entitled "Bridges over Navigable Waters of the United States." (Books #CG-425-1 and #CG-425-2).

Code "1" if the bridge has navigation control, "0" if no control exists. Our bridge is coded as "0".

Code: 0

Item 39 - Navigation Vertical Clearance: 3 Digits

If Item 38 has been coded "1", record in feet the minimum clearance under the bridge measured above a point that is specified on a navigation permit issued by a control agency or from the above-referenced manuals.

The measurement will show the clearance that is allowable for navigation purposes and should be coded as a 3-digit number. If Item 38 has been coded



"0", code all zeroes to indicate not applicable.

This measurement can be found in a number of ways: by actually measuring the distance or by utilizing the information contained in the Coast Guard publication identified for Item 38. If not applicable, code "000".

The code for our bridge is "000".

Code: 0 0 0

Item 40 - Navigation Horizontal Clearance: 4 Digits

If Item 38 has been coded "1", record for this item the minimum horizontal clearance in feet.

This measurement should be that shown on a navigation permit and may be less than the structure itself allows. Code the clearance as a 4-digit number. Code all zeroes if Item 38 is coded "0".

The most accurate way of finding the clearance is to actually measure it. The Coast Guard publication mentioned could also be used. The measurement for our bridge is "0000".

Code: 0 0 0 0

Item 41 - Structure, Open or Closed to Traffic: 1 Digit

The code for this item is based on the information shown in the guide. If the bridge is closed to all traffic, code "C". It is important to note that this is intended to correspond to a code of "0" or "1" in any one or all of Items 59, 60 or 62. If a bridge is open to traffic, but a load limit is posted, code "P". If a bridge is open to traffic with no load restrictions, code "A". Code our bridge "A".

Code: A

Item 42 - Type Service: 2 Digits

This item is provided to show the type of service on the bridge and

the type of service under the bridge. Code according to the options provided on page 16 in the guide. Our bridge would be coded as a "15". To use the Highway-Pedestrian Code, be sure that there is actually a place for pedestrians to travel (other than a curb).

Code: 1 5

Item 43 - Structure Type, Main: 3 Digits

Code the information for the main span according to the codes provided on page 17 in the guide and on page 2 of the Kentucky supplement. Be sure the code in the second and third digits does not exceed "19". Our bridge is coded as "104".

Code: 1 0 4

Item 44 - Structure Type, Approach Spans: 3 Digits

Using the same codes as for Item 43, code the type of structure found in the approach spans to a major bridge. Also, follow instructions in the guide for coding in special cases. If no approach spans exist, leave blank. For our bridge, we would leave this item blank.

Code: \_ \_ \_

Item 45 - Number of Spans in Main Unit: 3 Digits

For this item, indicate the number of spans in the main or major unit. Include all spans of most bridges. For a sizable structure, include the main unit only. If the material or design of a main unit is different from that of the approach spans, code the item on that basis. The code for this item must be numeric and greater than "0". The number of spans in our bridge is 4 and should be coded "004".

Code: 0 0 4

Item 46 - Number of Approach Spans: 4 Digits

Code the number of spans in the approach spans to the major bridge, or the number of spans of material different from that of the major bridge. The code for our bridge is "0000".

Code: 0 0 0 0

Item 47 - Total Horizontal Clearance: 3 Digits

The horizontal clearance for the route identified in Item 5 should be measured and coded to supply information that meets the reporting requirements of the Department of Defense. According to the guide, clearance should be "the available clearance measured between the most restrictive features." Level 1 (on the bridge) and level 2 (under the bridge) are to be both measured and coded on highways over highways. If curbs or barrier walls are the most restricted feature, measure to the bottom of each at the junction of the deck. The total horizontal clearance on level 2 under the bridge is to be the width of the roadway surface and usable shoulders. The important item to consider is the words "most restrictive features."

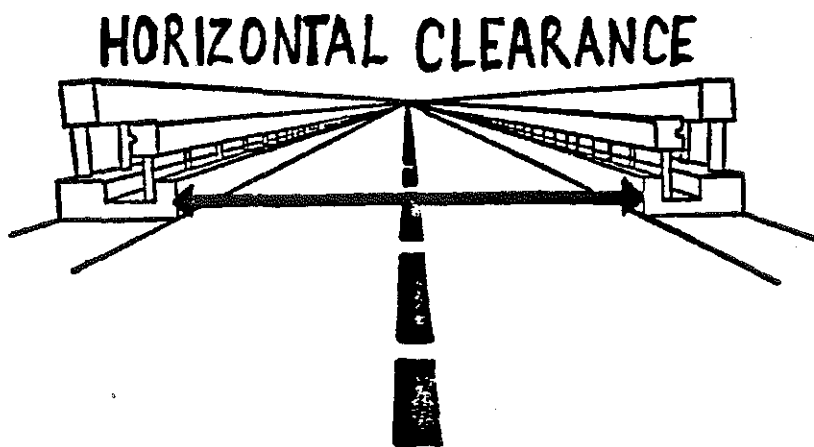

The measurement should be made to the nearest 10th of a foot. The horizontal clearance for our bridge is 26.0', which would be coded as "260".

Code: 2 6 0

Item 48 - Length of Maximum Span: 4 Digits

The span length shall be measured and coded as the clear opening distance between piers, bents or abutments. If abutment caps overhang the breastwall, measure to the breastwall just below this cap. Trusses and bridges with rockers are to be measured from center to center of bearing device. The measurement should be to the nearest foot. This item must be numeric and greater than 0 or an error will occur. The length of the maximum span for our bridge is 50'.

Code: 0 0 5 0

Item 49 - Structure Length: 6 Digits

Measure and code a 6-digit number to represent the length of the structure to the nearest foot. The length should be measured back-to-back of backwalls or abutments or from paving notch to paving notch, as discussed in the guide and the AASHTO Bridge Maintenance Manual. Our bridge would be coded "000213".

Code: 0 0 0 2 1 3

Item 50 - Sidewalk Widths: 6 Digits

The width of the bridge sidewalks should be measured and coded to the nearest 10th of a foot. The first three positions are for the left sidewalk (in the direction of inventory) and the remaining three are for the right sidewalk.

No sidewalks exist on our bridge; therefore, our code is "000000".

Other examples are shown on page 19 in your guide.

Code: 0 0 0 0 0 0

Item 51 - Bridge Roadway Width - Curb-to-Curb: 4 Digits

This item is included to measure the distance of the roadway between the curbs of the bridge. This may be the same as Item 47 on most bridges. Additional information on this item appears on page 19 in your coding guide.

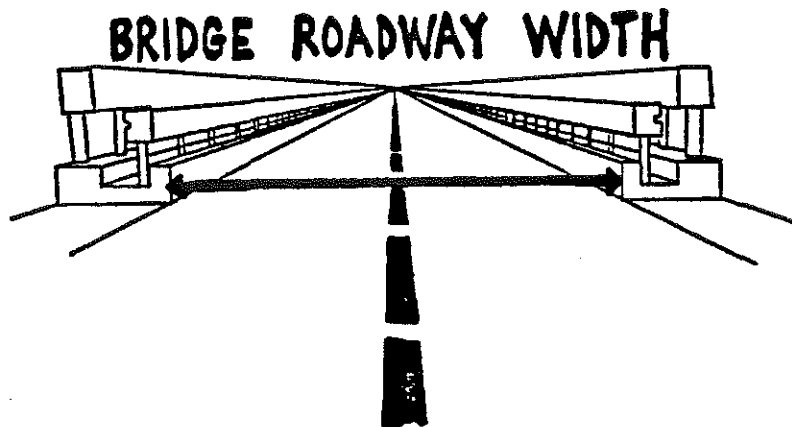

The measurement for our bridge is 26.0'.

Code: 0 2 6 0

Item 52 - Deck Width (Out-to-Out): 4 Digits

Code a 4-digit number to show the out-to-out width of the deck to the nearest 10th of a foot.

### DECK WIDTH (OUT-TO-OUT)

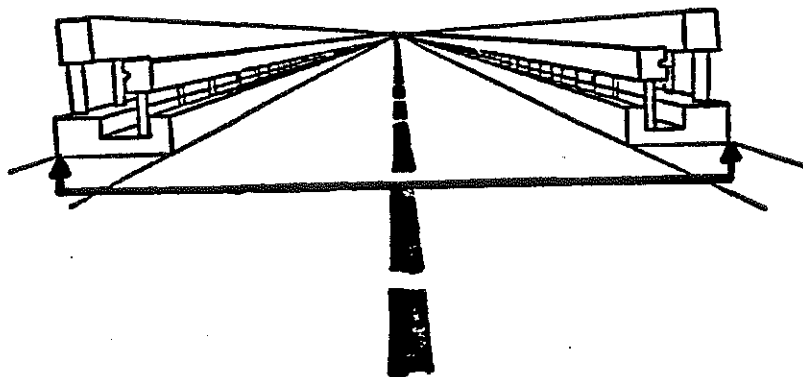

The measurement should not include flared areas. The out-to-out width for our bridge is 30.2'.

Code: 0 3 0 2

Item 53 - Minimum Vertical Clearance Over Bridge Roadway: 4 Digits

This item is the actual minimum vertical clearance over the bridge roadway, measured to the nearest inch. When no superstructure restriction exists above the bridge roadway, the clearance should be coded "9999". In the first two positions, code feet; in the next two, inches. For clearances in excess of 30', estimate the clearance. Code our bridge "9999".

Code: 9 9 9 9

Item 54 - Minimum Vertical Underclearance: 4 Digits

Code, in feet and inches, the minimum vertical clearance from the roadway or railroad track beneath the structure to the bottom of the superstructure. Code zeroes for structures over any other feature. Since our bridge is over water, code "0000".

Code: 0 0 0 0

Item 55 - Minimum Lateral Underclearance on Right: 3 Digits

This item is provided to measure the clearance for a roadway or railroad travelling under the structure. If not either of these two cases, code "999".

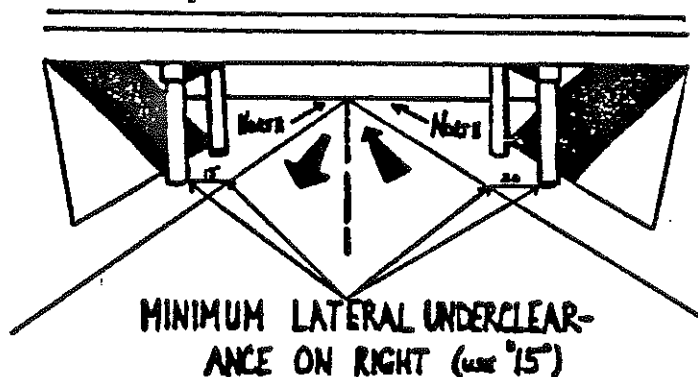

The lateral clearance is measured for the right edge of the roadway, considering both directions of travel. Both measurements are compared and the smallest is coded to the nearest 10th of a foot.

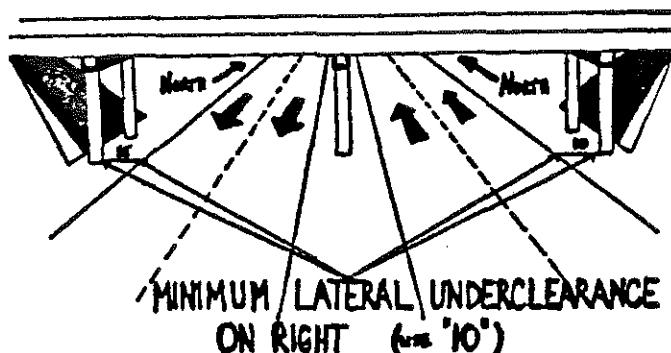

In the case of a divided highway, the same approach would be used.

For our structure, code "999".

Code: 9 9 9

Item 56 - Minimum Lateral Underclearance on Left: 3 Digits

(For divided highways only)

This item refers to the lateral clearance on the left edge of the roadway beneath the structure for both directions of travel.

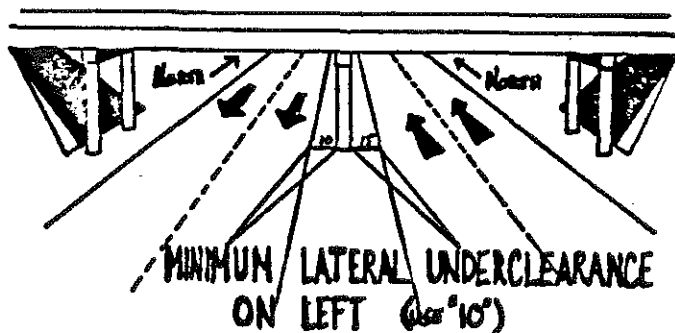

Measurements are noted to the nearest 10th of a foot and the smallest measurement is coded. If no obstruction is in the median area under the structure, code "999". If the feature under the structure is neither a railroad nor a highway, code "000". Our bridge would also be "000".

Code: 0 0 0

Item 57 - Wearing Surface: 1 Digit

The kind of wearing surface material on the structure should be coded according to the options available in the guide. The wearing surface for our bridge is concrete, so it will be coded as a "1".

Code: 1

8. CONDITION RATINGS

The next few items are designed to collect data about the condition of various portions of the bridge structure. They result directly from each bridge inspection. The scales for each of these conditions are based on the AASHTO scale and are discussed in more detail in the next topic.

To determine a rating for each item, the bridge inspector will have to exercise sound judgement and reasoning as these ratings are based on the evaluation of all the factors relating to the item under consideration.

All codes must be "0" through "9", or "N" for "Not Applicable."

As a guide, the condition ratings on page 27 of the FHWA Coding Guide can be interpreted for use in Kentucky as follows:

| <u>Rating</u> | <u>Description</u>                    | <u>Adjectival Equivalent</u> |
|---------------|---------------------------------------|------------------------------|
| N             | Not Applicable                        | Not Applicable               |
| 9             | New Condition                         | New Condition                |
| 8             | Good Condition - no repairs necessary | Good                         |



| <u>Rating</u> | <u>Description</u>   | <u>Adjectival Equivalent</u> |
|---------------|--|------------------------------|
| 7             | Generally Good Condition - potential exists for <u>minor maintenance</u> . The work required would consist of cleaning decks, cleaning drains, etc.  | Good                         |
| 6             | Fair Condition - potential exists for <u>major maintenance</u> . Corrective action for this category would include activities such as patching decks, patching abutments, etc., <u>without</u> the need for repair plans and specs. This work would usually be done by State forces. | Fair                         |
| 5             | Generally Fair Condition - potential exists for <u>minor rehabilitation</u> . In this case, plans and specs would be required to complete the work. The terms "rehabilitation" and "repair" should be considered synonomous.   | Fair                         |
| 4             | Marginal Condition - potential exists for <u>major rehabilitation</u> . A rating of 4 for the superstructure will require that the bridge be posted.   | Poor                         |
| 3             | Poor Condition - repair or <u>rehabilitation required immediately</u> . If the superstructure is rated with a 3 the bridge should be posted to be closed to truck traffic.   | Poor                         |
| 2             | Critical Condition - the need for <u>repair or rehabilitation is urgent</u> . Facility <u>should be closed until the indicated repair is complete</u> .  | Critical                     |
| 1             | Critical Condition - <u>facility is closed</u> . Study should determine the <u>feasibility</u> for repair and determine when the facility can be reopened.   | Critical                     |
| 0             | Critical Condition - facility is <u>closed and is beyond repair</u> .  | Critical                     |

Item 58 - Deck: 1 Digit

The rating for this item should be based on the condition of the elements which comprise the deck. For our bridge, this item would be rated "6".

Code: 6

2-8-33

Item 59 - Superstructure: 1 Digit

As stated in the guide, this item includes all structural members, bearing devices, and any drainage system. This item is rated "6" for our bridge.

Code: 6

Item 60 - Substructure: 1 Digit

This item includes piers, abutments, piles, footing scour conditions, or other. For our bridge, code "6".

Code: 6

Item 61 - Channel and Channel Protection: 1 Digit

Stream stability and condition of riprap, spur, dike, etc., are included in this item. However, the condition of the retaining walls is usually rated with this item for reasons which will be discussed momentarily. The rating for our bridge is "5". In this case, a contract should be let and a soil study conducted.

Code: 5

Item 62 - Culvert and Retaining Walls: 1 Digit

The guide explains that this item includes culvert alignment or settlement problems, retaining wall stability, and structural integrity. However, if the structure is not a culvert, you must code "N". As a result, you have no place to reflect retaining wall condition. This can be shown with Item 61 as it is closely related to the channel and channel features. Since we are rating a bridge, the appropriate code for this item is "N".

Code: N

Item 63 - Estimated Remaining Life: 2 Digits

The coding guide says that the remaining life of the structure should be estimated "based on all related and appropriate factors such as material, traffic volumes, age, and other. The estimate, which should be

made using the best judgement of a knowledgeable individual, should reflect the remaining life without major reconstruction." In order to provide a basic frame of reference as to the life of a bridge, guidelines are provided on page 3 of the Kentucky commentary. In any case, judgement is a key factor. The estimated remaining life coded for our bridge is approximately 35 years.

Code: 3 5

Item 64 - Operating Rating: 3 Digits

The operating rating referred to in the guide is explained in the AASHTO Bridge Inspection Manual. It is based on the results of a stress analysis on the structure conducted by qualified professional engineers. The stress analysis is conducted to determine, based on the design and condition of the bridge elements, the total amount of stress or loading the structure will bear. Two stress levels are then calculated from the stress analysis results. The first, or upper level, is called the operating rating. The operating rating is defined by AASHTO as the maximum permissible H, HS, or other load to which a structure may be subjected.

The Kentucky Department of Transportation has a computer program and procedure for calculating the stress analysis. Engineering personnel have been trained to utilize this capability to assist in the analysis. The analysis procedures will be discussed in more detail in a later section.

Once the analysis has been completed and the operating rating assigned, it must be coded according to the format suggested in the guide. The first digit will show the loading and must be 1 through 9. The second and third digits will give the gross loading in tons, except pedestrian and railroad loading. For railroad loading only, the second and third digits will give Cooper Class or equivalent. Code pedestrian loading as "800". Additional guidance is provided on page 4 of the Kentucky commentary.

2-8-35

The operating rating for our structure is "261". This code represents a gross HS vehicle weight of 61 tons which converts to an HS loading of 34 tons.

Code: 2 6 1

Item 65 - Approach Roadway Alignment: 1 Digit

As discussed in the guide, for this item give the rating in relation to the effect on the use of the bridge. In rating approach roadway alignment, consider the impact at the end of the bridge due to uneven approaches as well as the approach roadway curvature. For our bridge, a rating of "5" has been assigned.

Code: 5

Item 66 - Inventory Rating: 3 Digits

The information and coding scheme discussed for Item 64 - Operating Rating, is the same. However, the inventory rating is defined as "the load which can safely utilize an existing structure for an indefinite period." The inventory rating is the rating determined by the design stress of a bridge. A stress of 55% yield stress is used to determine inventory rating. All bridges with analyses results will be coded for the gross load for the H or HS truck as 55% of the yield stress.

Examples:

|   |          |
|---|----------|
| Bridge Design H-15                                  | Code 115 |
| Bridge Design HS-15                                 | 227      |
| Bridge Design HS-20                                 | 236      |
| Temporary or closed bridge                          | 900      |
| Bridge analyzed to have a 9-ton<br>inventory rating | 109      |

The inventory rating will always be less than or equal to the operating rating. The inventory rating assigned for this structure is "126" for a gross

truck loading of 26 tons which is the same as the H truck loading of 26 tons.

Code: 1 2 6

## 9. APPRAISAL RATINGS

Appraisal ratings are assigned to structures based upon a comparison of the structure to existing design criteria. The Kentucky Department of Transportation has prepared special guidelines to assist in the coding of these items. These guidelines will be reviewed in the next section of the program.

The intention of the "Appraisal" section is to evaluate a bridge in relation to the highway system and functional classification of which the bridge is a part. The individual deficiencies in the various rated items need to be evaluated as to how they affect the bridge as a unit. The structure, then, would be compared to a new one built to the State's current standards for that particular type of road. On this basis, it is not always necessary to use the highest standard, but it is not recommended to use unduly low standards. It is recommended that AASHTO standards be followed for establishing design, minimum adequate and intolerable categories, unless the State's approved criteria differ from those in the AASHTO guides.

Items 67 through 72 will be coded with a one-digit code that indicates the condition rating for the item. The ratings and codes are:

- N Not applicable
- 9 Conditions superior to present desirable criteria
- 8 Conditions equal to present desirable criteria
- 7 Condition better than present minimum criteria
- 6 Condition equal to present minimum criteria
- 5 Condition somewhat better than minimum adequacy to tolerate being left in place as is
- 4 Condition meeting minimum tolerable limits to be left in place as is
- 3 Basically intolerable condition requiring high priority of repair
- 2 Basically intolerable condition requiring high priority of replacement

- 1 Immediate repair necessary to put back in service
- 0 Immediate replacement necessary to put back in service

Item 67 - Structural Condition: 1 Digit

This item is one of the most important items in the analysis of the bridge's condition. Here you must weigh the relative importance of ratings assigned to the structural elements and determine an appraisal rating for the structure. Record major structural deficiencies and code the rating. The condition of the deck should have a relatively small influence on the appraisal rating assigned to Item 67 and rarely should the appraisal rating for the structural condition be less than "4" due to a bridge deck problem. Exceptions to this would be concrete slab, T-beam and box girders. The minimum numerical rating of "4" is realistic if only the bridge deck needs replacement and the rest of the supporting superstructure is to remain in place. A lower rating could be justified if a significant amount of additional reconstruction or replacement is required on the rest of the superstructure to restore the load carrying capacity of the bridge.

The bridge is appraised not only on physical condition of the superstructure and substructure, but also on structural capacity. Therefore, a well-maintained bridge may still be appraised at a "4" or "5" because the original design load was less than today's standard.

Of first importance are those items whose malfunction or loss would adversely affect the integrity of the structure. For example, a loose expansion device, a pier cap that needs concrete work or a damaged truss portal should not classify a bridge as a "basically intolerable condition."

For our bridge, a code of "5" was assigned.

Code: 5

Item 68 - Deck Geometry: 1 Digit

The deck geometry is another important item. This refers to adequacy of roadway width, clearances above deck, and other conditions. As a guide, 14' 6" is the present above deck clearance minimum criteria on roads other than interstates and parkways. On those roads, 16' 0" is the present minimum criteria.

If a structure has a curb-to-curb greater than, or equal to, the approach pavement (not including shoulders), a code of "4" or greater is to be used. For a structure with a curb-to-curb less than the approach pavement (not including shoulders), a code of "3" or less is to be used. The Kentucky DOT Basic Geometric Design Criteria that has been provided as a handout will give the desirable bridge width (curb-to-curb) by adding the pavement width and shoulder widths for a given ADT.

Our bridge has been rated as a "5".

Code: 5

Item 69 - Underclearances, Vertical and Horizontal: 1 Digit

This refers to the vertical and horizontal underclearances from the through roadway to the superstructure or substructure units, respectively. Code "N" if over water.

The vertical underclearance between a highway and the bridge carries the same criteria as the highway vertical clearances in Item 68 - Deck Geometry. Vertical underclearances between a railroad and the bridge meet desirable criteria at 25' 0", are equal to minimum criteria at 23' 0", and meet minimum tolerable limits, to be left in place, at 21' 0". A lateral right clearance of 12' 0" meets desirable criteria.

Since our bridge is over water, code "N".

Code: N

Item 70 - Safe Load Capacity: 1 Digit

Record deficiencies and code rating in accordance with appropriate system criteria. It should be noted that the National Bridge Inspection Standards require the posting of load limits only if the maximum legal loads in the State produce stresses in excess of the operating rating stress level. This safe load capacity should be entered as Item 70. If the safe load capacity is such that posting is required, Item 70 shall be coded as "4" or less. If no posting is required, Item 70 shall be coded as "5" or greater.

Item 70 evaluates the safe load of a bridge in comparison to the State legal load. In a way, Item 70 merely reflects the relationship between the load that may legally use the bridge and the required capacity for bridges on the same highway system. It differs from the appraisal of the Structural Condition in that Item 67 uses the inventory or design rating, while the Safe Load Capacity may be based on any stress level between inventory and operating ratings inclusive.

The use or presence of a temporary bridge again affects the coding. The safe load rating should reflect either the actual capacity or the posted load, if any, of the temporary bridge. This also applies to bridges shored up or required on a temporary basis.

Our bridge has been coded "8".

Code: 8



Item 71 - Waterway Adequacy: 1 Digit

As shown in the guide, this item describes the waterway adequacies and all scour erosion, condition of slope protection, stream capacity, etc., should be recorded. Our bridge is rated "4".

Code: 4

Item 72 - Approach Roadway Alignment: 1 Digit

Code the rating based on the adequacy of the approach roadway alignment. Sight distance, roadway alignment - both horizontal and vertical - and other conditions should be considered when rating this item. The approach roadway alignment for our bridge has been coded as "4".

Code: 4

10. PROPOSED IMPROVEMENTS

The remaining items of the S.I.& A. Report are related to proposed improvements to the structure, except Item 90 - Date of Inspection. The coding guide provides sufficient direction for completion of each item. You should document your bridge improvement recommendations and code them as appropriate. These items can provide the basis for bridge replacement and maintenance planning. We will briefly discuss each of these at this time.

Item 73 - Year Needed: 2 Digits

The information to be recorded for this item will be the year improvements are estimated to be needed. The determination of the year can be made through the State's normal highway planning procedures.

A 2-digit number will be coded to represent this information. Use zeroes to indicate "no answer" or "improvement not needed."

Example:

| Improvement Needed | Code |
|--------------------|------|
| 1970               | 70   |
| 1975               | 75   |
| Not given          | 00   |
| None Needed        | 00   |

Item 74 - Type of Service: 1 Digit

Use the code shown in Item 42 to represent the type of service to be provided on the bridge.

Item 75 - Type of Work: 3 Digits

The information to be recorded for this item will be the type of work proposed to be accomplished on the structure to improve it to the point that it will provide the type of service specified in Item 74. A 2-digit number should be coded to represent the proposed work type. The codes below are similar to those used in preparing Form PR-37 for highway safety improvement:

- 30 Widening existing bridge or other major structure
- 31 Replacement of bridge or other structure because of condition
- 32 Replacement of bridge or other structure because of relocation of road
- 33 Construction of new bridge or major structure (except to eliminate a railroad grade crossing or one for pedestrians only)
- 34 Construction of pedestrian over - or under - crossing
- 35 Other structure work
- 36 Strengthening
- 37 Rehabilitation

In addition, a 1-digit suffix code should be used to indicate whether the proposed work is to be done by State forces or by contract.

|              |        |
|--------------|--------|
| Contract     | code 1 |
| State forces | code 2 |

Code all zeroes if not applicable

Example: Strengthen existing structure by contract would be coded 361.

Item 76 - Length of Improvement: 6 Digits

Code a 6-digit number that represents the length of the proposed improvement to the nearest foot. This length will not necessarily be the full length of the structure. Code all zeroes if not applicable. The total length of the eligible approach improvement only should be included.

| Length of Improvement | Code   |
|-----------------------|--------|
| 250 feet              | 000250 |
| 1200 feet             | 001200 |
| 12345 feet            | 012345 |

Item 77 - Proposed Design Loading of Improvement: 1 Digit

Use the codes as specified on Item 31 to show the design loading proposed for the improvement. Code zeroes if not applicable.

Item 78 - Proposed Roadway Width: 4 Digits

Code a 4-digit number to represent the width of the proposed reconstruction roadway to the nearest foot. The width will be from curb-to-curb or from face-to-face or rails if the curbs are 9 inches or less in width. Code zeroes if not applicable.

Item 79 - Proposed Number of Lanes: 2 Digits

Code a 2-digit number to indicate the number of lanes proposed as part of the improvement. Code zeroes if not applicable.

Item 80 - Design ADT: 6 Digits

Code a 6-digit number to represent the ADT which controls the design of the new improvement. The ADT should be to the nearest ten and coded as shown in Item 29. Code zeroes if not applicable.

Item 81 - Year of Estimated ADT: 2 Digits

Code a 2-digit number to represent the last two digits of the year of the estimated ADT given in Item 80. Code zeroes if not applicable.

Item 82 - Year of Proposed Adjacent Roadway Improvements: 2 Digits

Code a 2-digit number to represent the last two digits of the year in which it is expected that improvements to the roadway approaches to the bridge will take place. Code zeroes if not applicable.

Item 83 - Type of Proposed Adjacent Roadway Improvements: 1 Digit

Code a 1-digit number to represent the type of improvement proposed for the approaches to the bridge. Use the following codes:

- 0 Not applicable
- 1 Resurface
- 2 Reconstruction
- 3 Widening
- 4 Shoulder improvements
- 5 Other (explain in remarks)

Item 84 - Cost of Improvements: 5 Digits

Code a 5-digit number to represent the total cost of the proposed improvements in thousands of dollars. If the cost coded is for a replacement structure, it may be larger than the sum of Items 85 through 88, since it includes the necessary eligible approach work and other miscellaneous work. This item may also be used for coding maintenance costs.

Example:

| Cost of Improvement | Code  |
|---------------------|-------|
| \$ 55,850           | 00056 |
| 250,000             | 00250 |
| 7,451,233           | 07451 |

2-8-44

Items 85 through 88 are applicable to the Bridge Replacement Program. Code greater than zero only if Item 84 is coded for replacement cost. Otherwise, code all zeroes.

Item 85 - Preliminary Engineering Cost: 3 Digits

Code as a 3-digit number to represent the estimated cost in thousands of dollars of the preliminary engineering.

Item 86 - Demolition Cost: 3 Digits

Code as a 3-digit number to represent the estimated cost in thousands of dollars to demolish the existing structure.

Item 87 - Substructure Cost: 5 Digits

Code as a 5-digit number to represent the estimated cost in thousands of dollars to construct the substructure of the proposed improvement.

Item 88 - Superstructure Cost: 5 Digits

Code as a 5-digit number to represent the estimated cost in thousands of dollars to construct the superstructure of the proposed improvement.

Item 89 - Blank

Item 90 - Inspection Date: 6 Digits

Code the date the structure is inspected. The item should be coded in the form:

|        |     |       |
|--------|-----|-------|
| MM     | DD  | YY    |
| (month | day | year) |

REMARKS

In addition to any other applicable statements, remarks must include a statement of action taken, if any, pursuant to findings of inspection.

11. KENTUCKY COMMENTARY

In addition to completing all of the items just discussed on the

S.I. & A. form, Items 1A through 37A, as shown in the Kentucky Additions and Interpretations handout, are maintained on a computer file and will be required to be completed as a part of your inspection. Also, Items 1D through 19D are maintained in the computer file and are supplied by the Division of Bridges.