

Highway Materials Research Laboratory
132 Graham Avenue, Lexington 29, Ky.

January 26, 1949

File: S-3-2
D-1-2

Memo. to: Dean D. V. Terrell
Director of Research

Subject: Surfacing Materials for Signs and Markers

Early in 1948, the Research Laboratory developed a means for evaluating "reflex-reflector" surfaces (beaded sheet coatings) for signs and markers and recommended this to the Specifications Committee in a transmittal to Mr. Bray on January 29, 1948. Inasmuch as materials for this purpose are actually purchased by the Welfare Department for their use in fabricating signs at the LaGrange Reformatory, the specification was never adopted by the Highway Department to the best of my knowledge.

Even so, the Purchasing Department has bought materials under this specification for the past year, apparently with both the Highway Department and the Welfare Department agreeing on the requirements of the specification. Acceptance tests have been made in the Research Laboratory, since equipment for the purpose was here and more so since we wished to consider the specification as a temporary expedient "...which we are certain we can improve upon in the near future".

After a year of work we are recommending that the attached specification supersede the old one. Even though there may be some unknown features about relationships that apply to signs in service, this specification and the means that have been developed for testing are far, far superior to those that have been in use for the past year. Some reflectance and durability requirements for painted surfaces (Type I) have not been included in the table of optical properties because weathering tests for lasting qualities of these materials have not been carried to completion.

Regarding this feature of lasting qualities or durability-- which incidentally was not included in our specification last year-- we have no definite correlation between laboratory and field exposure. In the lab we used an accelerated weathering device of the carbon arc type to simulate sunshine, and ran some tests up to what we roughly considered equivalent to four years of field exposure. But we are not absolutely certain of the equivalent relationship, principally because no controlled field exposures for periods as long as four years have been

possible. That is a part of the extension of this project which we intend to carry out over a long period of time. For the present, however, we know that failures can be developed in the lab test, that most manufacturers have considerable faith in this test, and that sign surfacing materials show various degrees of durability against the accelerated exposure.

Other than the durability requirement included in this specification and missing from the other, there are much better means for evaluating reflectance. A device for this purpose was designed by Mr. J. H. Havens, Chemist, and Mr. Fred C. Curtis, part-time Engineering Aide and senior in Civil Engineering at the University. All parts were purchased commercially and assembled into a compact piece of equipment here. The equipment is fundamentally sound insofar as analogy to actual sign-headlight-driver relationships on the highway are concerned. Also, its light receiving and recording mechanism is so sensitive that appreciable reflectance readings for painted surfaces without reflectorizing media can be made under conditions equivalent to 400 ft. from driver to sign in the field. This is farther than a driver can actually see a painted sign.

Because of the superior qualities of this reflectometer as compared with the old button tester used for the preceding specification, it is now possible to place different surfacing materials into different classes according to their reflectance qualities. This provides a way for the traffic engineers to requisition materials under this specification in accordance with their needs for situations in the field as they find them. Thus, if reflectorized surfaces for some route markers are in question, yet a "sight-distance" of 250 feet is all that is desired, it will not be necessary to pay a premium for materials of greater reflectance value which could be seen at 400 feet. On the other hand, for situations of great danger it may be desirable to have a sign prominent at 700 feet, and thus material in the highest reflectance category can be purchased without fear of competition from lower reflectance materials because of price. In other words, the specification is selective from the standpoint of reflectance as well as durability. Incidentally, you will note that the specification applies to surfacing materials and hence does not include reflectors of the button type.

Your attention is called to the Divergence and Incident angle relationships in the tabulation at the end of the specification. As shown in the sketch which follows, the angle of

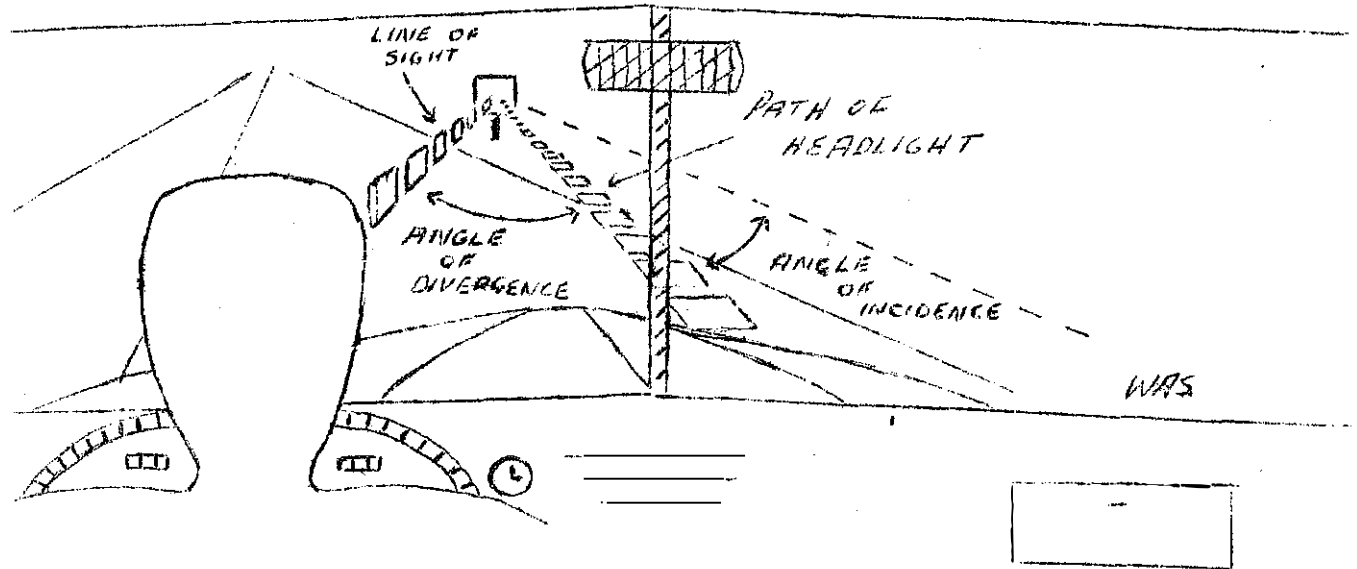

divergence (angle between "line of light" and "line of sight") is related to the distance from the sign, the angle being smallest at greatest distances. Hence, 0.5° angle of divergence represents about 400 feet distance from a sign on the highway, and the others are about as follows:

1°	=	200'
2.5°	=	75'
4.5°	=	25'

But more than this, the angle of incidence varies with distances from the sign because light from the headlamps does not strike a sign normal to its surface since the sign is some distance to the right of the pavement.

An average of about 4 feet was assumed for this offset distance, and, then for a level grade the incident angles vary from about 1° at 400 feet distance to 15° at 25 feet distance. However, since grade and alignment often requires approaches to signs that are quite different from a level, straight approach, a constant angle of 30° is included to require performance of the materials at these high incident-angle situations.

Because of these various relationships, the optical requirements tabulated at the end of the specification may prove cumbersome in time and part of them may be superfluous. However, until we know what is significant in the field and what isn't, we think it is best to establish specified values for a range of circumstances that are theoretically significant. Elimination of some optical requirements can be made later if that becomes desirable, but obviously all such requirements cannot be dropped because they are related to fundamental properties of the materials in question.

The effects of some surface accumulations which occur in laboratory weathering are not fully known. Whether they are comparable with those in the field and whether they represent city conditions or rural conditions best has not been determined. These may have considerable effect on the pronounced reduction in reflectance values for Type III-B materials after 600 hours exposure even though these materials do not crack or show loss of surface characteristics at 800 hours exposure. Whether this authentically represents field conditions is not as important at present as is the effect or amount of surface accumulation which might occur in different laboratories operating in different cities. That could affect the ability of manufacturers to correlate their evaluations of their materials with our own evaluations of materials that are offered. That is something that must be worked out.

In a conference which was arranged with Mr. Johnson, Director of Maintenance, and Messrs. Ringo and Brown, Traffic Engineers, on January 25, it was decided that the specification should be submitted to the Specification Committee with the recommendation that it be reviewed by the Engineer of Specifications, revised in detail if necessary, and ultimately be adopted by the Department of Highways if all necessary approval is obtained. Then, even though purchases of these materials would still be made by the Department of Welfare, the requisition by the Highway Department and the Invitation for bids issued by the Purchasing Department would carry the stipulation that the material must meet Highway Department Specifications when sampled and tested by Highway Department personnel. This would place those responsible for sampling and testing in the tenable position of acting for the Highway Department while operating under its specification. This is not the circumstance which existed heretofore when no one had definite responsibility or authority with regard to the vendor and his product.

It was further pointed out that tests under this specification would require 4 to 6 weeks for completion (depending upon the Type of material involved), and that the cost for each complete set of tests would be about \$400. That was the

reason for the stipulation on page 5, third full paragraph, requiring that "the expense of a second sampling and testing shall be borne by the vendor" provided material fails to meet performance requirements. This is made contingent on the "discretion of the Engineer and agreement of the vendor".

A complete report on experimental data which formed the basis for this specification will be made when results of field observations are available. Those field results will include not only observations and measurements on signs in service, but also determinations of distances at which drivers react to signs of the various types. That will enable the traffic engineers to evaluate the efficiency of their signs for various purposes and circumstances, and should provide a basis for determining how much reflectance is actually used insofar as drivers' reactions are concerned.

L. E. Gregg
Associate Director of Research

LG:mbm

Copies to:

Research Committee
Specifications Committee
L. E. Oberwarth
W. P. Ringo
C. P. Brown

Commonwealth of Kentucky
Department of Highways

Highway Materials Research Laboratory
Lexington, Kentucky

RECOMMENDED SPECIAL SPECIFICATION
FOR
SURFACING MATERIALS FOR SIGNS AND MARKERS

This special specification supersedes all previous specifications establishing requirements for surfacing materials for vertical signs and markers as defined below. This includes all previous special and temporary specifications and part 7.23.8B of the Department's 1945 Standard Specifications for State and Federal Road and Bridge Construction.

Materials

Materials used in the manufacture of reflectorizing systems not definitely specified herein shall be of the best quality and representative of ethical commercial practice and standards.

Unless otherwise designated either white or yellow colors are covered by all provisions of the specification. The term "sign stock" refers to either wooden or metal materials, either plain or embossed.

Classification

Surfacing materials shall be classed in accordance with their composition and structure as follows:

Type I - Both yellow and white baking enamel paints to be used as the finish coat for primed sign stock, applicable by either spray or brush.

Type II - Surfacing materials of the so-called "reflex-reflector" type which utilize minute lenses in the form of glass spheres imbedded in a pigmented binder having a characteristic color of either yellow or white. This type of materials shall be limited to those in which the binder or paint and glass spheres are applied separately, requiring application of binder to the primed sign stock by spray or brush and beads by dusting onto the still wet binder. The combination must be suitable for baking.

Type III - Commercially prefabricated reflex-reflectorizing plastic sheet coatings or decalcomania for application to primed sign stock by means of thermo-plastic adhesives. These materials shall be designated by class in accordance with their composition and structure as defined below.

Class A - Surfaces in which the glass spheres are bound by a clear plastic matrix supported by a lamination of pigmented or dyed plastic which contributes the characteristic color to the surface.

Class B - Materials which differ from Class A inasmuch as the glass spheres are bound by and imbedded into a pigmented (metallic or metallic oxide) matrix which contributes the characteristic color.

Class C - Materials in which the spheres lie totally within the matrix of transparent, tinted or otherwise colorless plastic so as to provide a smooth top surface. This may be supported

on a thin lamination of metallic sheeting which is an integral part of the reflectorizing system and contributes to the reflecting characteristics of the surface. These materials may or may not have thermo-plastic adhesive backings.

General Requirements

Colors of the surface materials of all types must conform strictly to the standards adopted by the Department, and the Engineer will be the sole judge of conformity. The correct shade will be furnished to manufacturers upon request.

When glass spheres form a part of the surfacing material, the spheres shall be clear, hard, and resistant to crushing or cutting by blunt or sharp instruments. They shall be stable under all atmospheric conditions and shall not deteriorate in the presence of weak acids or acid fumes.

Resistance to acids shall be determined by immersion of test panels (described under Sampling) in 0.1 N. Hydrochloric acid for 3 minutes. The panels shall show no bead loss under microscopic examination, and there shall be no deterioration of the beads as evidenced by discoloration of the panel surface.

Type I - No chemical composition is specified as it is the intent of the specification to allow the manufacturer to select and combine raw materials necessary to produce an enamel with solid coverage and hiding power. It shall not settle under storage to any extent that it cannot be easily adjusted to a consistency suitable for spray or brush. All enamels must be quick drying and suitable for baking.

Type II - It is the intent of the specification to permit the manufacturer to combine raw materials of their own

choice in order to produce reflectorizing systems of the highest quality, acceptable under the essential requirements for effective signs and markers. Components of the reflectorizing system purchased separately such as glass spheres and binder shall not require further processing or adjustment of properties before application. For example, the pigment of the binder shall not settle and cake under storage, requiring undue effort in effecting re-dispersion, nor shall the glass spheres cement or cluster together requiring mechanical separation. The binder shall be suitable for application by spray or brush, quick drying, and suitable for baking. The glass spheres shall be of uniform size and shape. They shall be clear and flow easily through mechanical dispensers. The diameter of the largest bead shall not exceed twice the diameter of the smallest bead.

Type III - All materials of this type shall consist of sheets or rolls requiring no further processing before application. They shall be applicable to primed sign stock and shall cover both embossments and smooth surfaces without any evidences of cracking or tearing, (as determined by observation of sign specimens described under Sampling). The adhesive and method of application shall be in accordance with the manufacturers' recommendation.

Sampling

For the purpose of sampling, a shipping unit shall consist of a single container (can, carton, or roll) of the material furnished by the vendor. A shipment shall consist of the total amount of material received in one delivery even though it may represent only partial delivery of the amount contracted.

Samplings shall be made from at least four widely separated and indiscriminately chosen points throughout a shipment, and not more than one sampling shall be made in any shipping unit. A sampling shall consist of enough materials to coat three individual 3-1/2" x 9" durability-reflectance test panels, and in the case of Type III surfaces, an additional amount of material sufficient to cover a 24" x 24" sign with embossments

shall be taken except when materials are purchased for flat-surface coating exclusively.

Samples of surfacing material shall be applied to the primed surfaces of metal test panels (having a minimum thickness equal to 28 gauge) and metal sign specimens by procedures recommended by the manufacturer for application of the material to signs and markers. The test panels and sign specimens shall be primed in accordance with usual procedures used in the sign shop or metal plant. Failure of test panels or sign specimens in the durability test by loss of adhesion between the primer and the metal shall not constitute basis for rejection of surface materials.

Containers of enamel for Type I and binder for Type II surfaces shall be observed for conformity to the general requirements applicable to those Types. Glass beads for Type II surfaces shall not be sampled for purposes other than the preparation of test panels. The beads shall be judged for uniformity of size and shape by microscopic examination of the test panels. Colors of all types of materials shall be judged by test panels or sign specimens.

In case materials taken in the first sampling fail to meet performance requirements hereinafter specified, a second sampling may be taken at the discretion of the Engineer and agreement of the vendor. The expense of a second sampling and testing shall be borne by the vendor.

Testing

Performance requirements for all types of surfacing materials shall be determined on the basis of durability and reflectance value initially and following exposure in the durability test.

Apparatus. - Equipment for evaluation of test panels shall consist of an optical microscope capable of 90 power magnification, a refrigeration unit which will maintain a constant temperature of $0^{\circ}\text{F.} \pm 5^{\circ}$, a water spray, and a reflectometer and accelerated sunshine weathering device having the following or equivalent characteristics:

Reflectometer. The reflectometer shall consist of a light source, photo electric cells, shunt, galvanometer, and a light trap with specimen holder. The light trap and specimen holder shall be separate from the light projection-measuring portion in order that the distance from source to sample may be varied. The bulb of the light source shall have a tungsten filament capable of producing a nearly parallel beam of light approximately two inches in diameter when used in combination with a condensing lens.*

There shall be four or five (as many as can be conveniently accommodated)

barrier-layer type photo cells each exposing a disk of sensitive surface approximately 3.7 cm. in diameter

*A 32-50 candle, 6 to 8 volt auto head lamp bulb serves this purpose very well in combination with a plano-convex lens suitable for focusing. This requires a transformer if 110 volt power is used. A voltage regulator, preferably of the automatic type, should be used between the transformer and the line source in order to maintain the power and have the light constant.

SCHEMATIC DIAGRAM OF REFLECTANCE APPARATUS

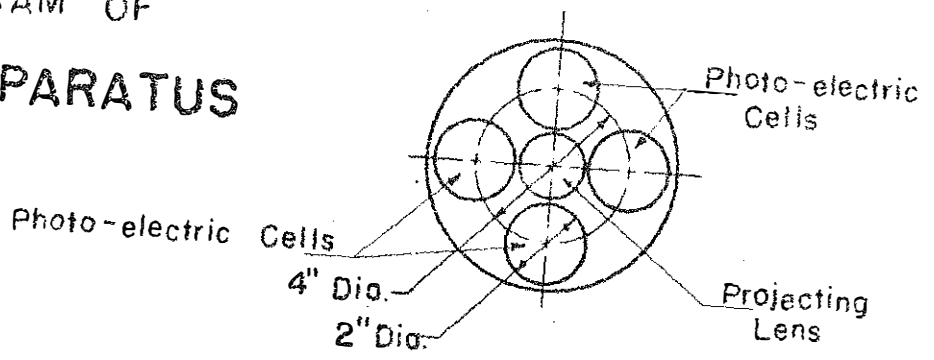

FRONT VIEW OF PHOTO-ELECTRIC
CELLS AND PROJECTING LENS

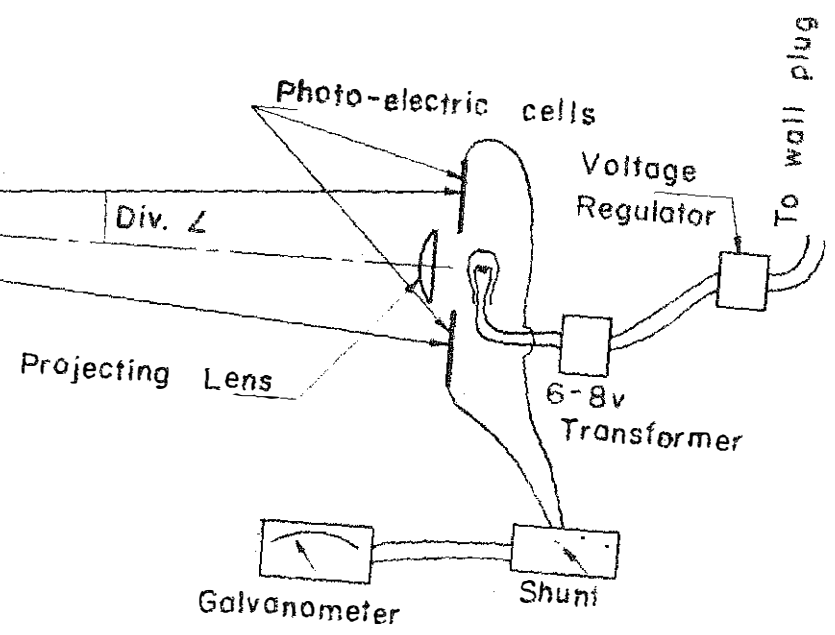
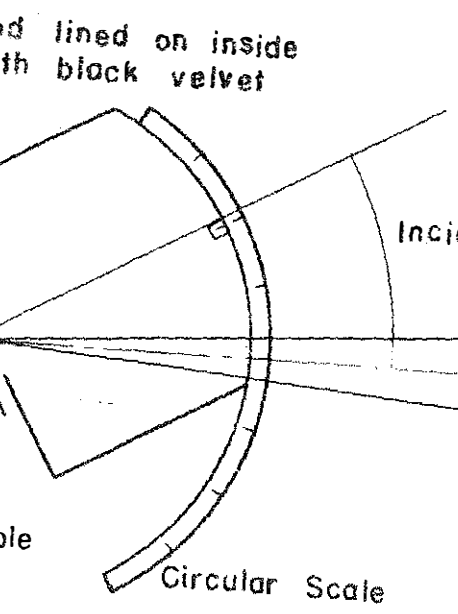
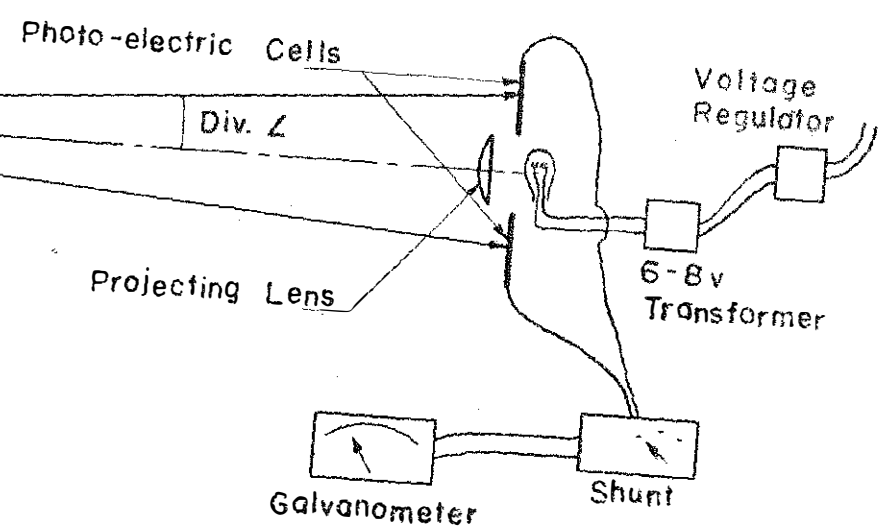
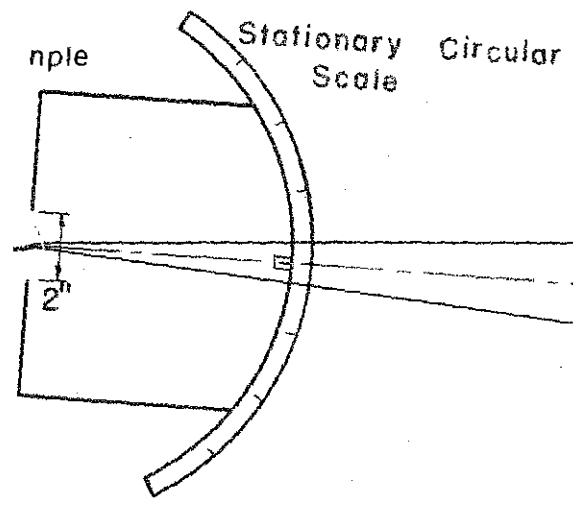

oriented around the projection lens such that the distance from the center of the cell to the center of the lens is two inches. The cells shall be matched as well as possible for linearity and sensitivity. They shall be capable of delivering approximately 3 micro-amperes per foot candle individually. All cells shall be arranged about the perimeter of the lens of the light source and connected in parallel. Their faces shall be perpendicular to the beam of light.

The leads from the photo cell group shall be connected to a single reflection type galvanometer having a sensitivity of at least 0.033 micro-amperes per m.m., an internal resistance of 45 ohms, and an external critical dampening resistance of 2640 ohms. A decade type shunt with ranges from 1 to 0.0001 in steps of ten shall be included in the circuit between the cells and galvanometer in order to adjust the range. The scale of the galvanometer shall be calibrated in terms of lumens or foot candles.

The light trap shall consist of a rectangular box having inside dimensions of approximately 10" x 10", and lined on the

inside with black velvet. The back of the trap shall have a two-inch diameter opening centered horizontally and vertically, and behind this a recessed specimen holder approximately $4'' \times 9\frac{1}{2}''$ oriented so that the longer dimension is vertical. Surfaces of the test panels and specimen holder shall be such that when a test panel is in place in the specimen holder and light is projected through the two-inch diameter hole onto the panel, only a two-inch diameter area approximately in the center of the specimen shall be illuminated, all other portions of the surfaced face of the panel being hidden.

The light trap shall be mounted on a pivot and circular base calibrated so that horizontal angles of orientation between the trap and the base can be measured accurately to 0.5° up to 30° . Outside surfaces of the trap and base (except for the scale) shall be painted flat black. The projection-receiving unit and the light trap-specimen holder shall be mounted separately and such that the distance of projection can be varied. The entire apparatus shall be

operated only in a totally dark room. All surfaces near the test area should be painted flat black.

Accelerated Weathering Device. Accelerated weathering shall be accomplished with a National Carbon Arc Type X-1A device using Corex D filters, sunshine carbons, and the intermittent water spray attachments. Provision shall be made for exposure of samples in an inclined position, the panel being placed with its longer dimension radially from the arc to the outside of the device, and inclined at an angle of 15° with the horizontal.

Methods. - Two of the three test panels shall be exposed to accelerated weathering. The third panel shall be filed for comparative purposes.

Durability. Accelerated weathering shall include both vertical and inclined exposure with intermittent water spray in the weathering device approximately 5 minutes every 56 minutes. The test samples shall be removed at 20 hour intervals, subjected to a turbulent spray of tap water for 30 minutes, and cooled to 0°F . for 30 minutes. They shall be examined microscopically at 100 hour intervals and the

condition of the surface recorded.

Reflectance. - Reflectance shall be measured as the percentage of light incident to the surface reflected back to the receiver. The intensity of the light at the specimen holder shall be measured with a standardized foot-candle meter. The amount of light reflected shall be converted from galvanometer readings. The equation for calculating the percentage of light reflected shall be:

$$R = \frac{\text{reflected light}}{\text{incident light}} \times 100 = \frac{L}{L_0} \times 100$$

The percentage of light reflected shall be determined for all panels for each of the conditions shown in the table of optical requirements.

Performance Requirements

All panels shall satisfy all conditions specified for each type and class. Failure of a single panel shall constitute basis for rejection.

Durability. - Both inclined and vertically exposed panels shall endure the specified number of hours of exposure in the accelerated weathering process without any evidence of cracking, chalking, peeling, or loss of glass spheres, as follows:

<u>Classification</u>	<u>Hours of Exposure</u>
Type I	
Type II	800
Type III	
Class A	400
Class B (white & yellow) ..	800
(silver)	400
Class C	400

Reflectance. - All panels shall meet the initial reflectance requirement for the appropriate type or class of surfacing materials. Failure of a single panel to meet these requirements shall constitute basis for rejection. Reflectance requirements after 600 hours of accelerated exposure shall be determined for the single panel exposed in the inclined position, and failure to meet this requirement shall constitute basis for rejection. Reflectance requirements are as follows:

OPTICAL REQUIREMENTS FOR SURFACING MATERIALS FOR SIGNS AND MARKERS

Color	Angle of Divergence	Angle of Incidence	Percentage of Incident Light Received									
			Type I		Type II		Type III					
			Initial	600 hrs.	Initial	600 hrs.	Class A		Class B		Class C	
						Initial	600 hrs.	Initial	600 hrs.	Initial	600 hrs.	
Yellow	4.5°	15°	.60	.45	1.85	.88	1.90	1.08	1.75	1.08	1.81	1.50
		30°	.50	.35	1.63	.80	1.40	.75	1.70	.84	.60	.41
	2.5°	5°	.18	.13	.50	.23	1.15	.29	1.02	.32	1.55	.81
		30°	.11	.08	.45	.20	.65	.28	.75	.36	.19	.08
	1°	2°	.07	.02	.11	.08	.36	.13	.38	.22	1.00	.57
		30°	.03	.01	.10	.07	.25	.10	.28	.14	.52	.04
	0.5°	1°					.15	.06	.22	.11	.60	.26
		30°					.11	.01	.15	.01	.03	.01
White	4.5°	15°	.90	.80	2.50	1.50	2.72	1.52	2.78	2.05		
		30°	.74	.65	2.20	1.35	1.90	1.03	2.50	1.64		
	2.5°	5°	.30	.20	.75	.30	1.65	.39	1.66	.82		
		30°	.18	.15	.68	.37	.96	.36	1.21	.75		
	1°	2°	.08	.05	.17	.13	.60	.17	.58	.45		
		30°	.04	.03	.15	.10	.32	.14	.39	.31		
	0.5°	1°					.20	.08	.28	.22		
		30°					.16	.01	.20	.03		
Silver	4.5°	15°					3.00	1.70	3.35	2.00		
		30°					.72	.50	2.55	1.20		
	2.5°	5°					2.80	1.20	2.50	1.25		
		30°					.20	.12	1.60	.85		
	1°	2°					2.05	.50	1.50	.75		
		30°					.07	.04	.85	.42		
	0.5°	1°					1.25	.30	1.05	.55		
		30°					.04	.01	.52	.06		

176