



M. W. TINDER
COMMISSIONER OF HIGHWAYS

COMMONWEALTH OF KENTUCKY
DEPARTMENT OF HIGHWAYS
FRANKFORT

April 13, 1955

ADDRESS REPLY TO
MATERIALS RESEARCH LABORATORY
132 GRAHAM AVENUE
LEXINGTON 29, KENTUCKY

ATTENTION:

MEMO TO: D. V. Terrell
Director of Research

Shortly after the discussion of rock asphalt pavements which was held at the request of Mr. Bray about two weeks ago, inspections were made on four or five roads surfaced with this material during recent years. Evidences of stripping action were investigated rather thoroughly, and samples were taken for examination and tests in the laboratory.

On the basis of these limited studies, the attached "Preliminary Report on the Performance of Kentucky Rock Asphalt" has been prepared by J. H. Havens and E. G. Williams. The intent of this report is to show what has been found with regard to the underlying cause of the pavement distress, to record a few ideas on the manner in which the cause might have developed, and to make recommendations concerning research that should be carried out to determine whether and how rock asphalt can be used and controlled satisfactorily in the future.

Inasmuch as we have inspected only a very small portion of the projects placed within the last few years, we are not prepared to estimate how widespread the failures may be. We do know that performance can vary from extremely poor to excellent with materials that fall within specification limits and which presumably were placed on the road by approved methods. Also, we know that the material can be quite variable and meet the specifications. This is no special condemnation of our specifications since they are essentially the same as specifications elsewhere; instead it emphasizes the limit of our knowledge of what should be quality requirements for a material of this description.

The information that is presented here leaves no doubt that stripping of bituminous binder from the sand grains accounts for the failures that occurred. No bituminous-aggregate combination, natural or otherwise, which becomes as devoid of binder as some of the specimens that were observed could remain intact under traffic of any

magnitude. We are reasonably certain that the sand grains themselves do not offer any exceptional resistance to coating and adhesion by the bituminous binder, hence the fault lies in the binder and possibly in the way it is treated. As an absolute minimum more definite physical requirements pertaining to the binder are needed.

In order to determine whether suitable test requirements can be established, and whether the variabilities of the rock asphalt are such that it can be controlled and used dependably, we propose a combined field, laboratory, and production study consisting of the following:

1. Investigation of production procedures to determine the variations that apply to the material normally obtained, and the effects of certain secondary production features such as stock-piling and conditions of curing on the physical properties that are achieved.
2. Sampling of representative pavements in service to determine the range of binder qualities represented at areas where failures have and have not occurred.
3. Development of laboratory test data showing the composition of binder materials and the influence of constituents on adhesion and resistance to stripping from sand grains in the rock asphalt.

Satisfactory completion of these studies should lead to reasonable bases for specifying the variations in rock asphalt that are acceptable for high quality work. At that time probably it would be desirable to correlate the data with field applications, and test sections on a suitable paving project may be sought. But, until we have this essential background, I doubt that research on any paving project would be fruitful.

Undoubtedly the factors causing stripping can be determined rather clearly through the procedures we recommend, but whether we can develop new specification provisions that will assure dependable pavements remains to be seen. The material as it occurs in nature may not be uniform enough to make rigid control possible. Even then treatment with additives to improve binding qualities might be feasible, but of course that is largely a problem for the producers.

If the things we propose are approved and complete study is desired, we are prepared to start work on it immediately. It is difficult to estimate the time required to go through the steps outlined above,

D. V. Terrell

- 3 -

April 12, 1955

but at least several months would be involved. In the meantime, the existing specifications and control should be regarded as inadequate, and results on paving projects may be good or bad depending upon factors that can not be defined at present.

Respectfully submitted,



L. E. Gregg
Assistant Director of Research

LEG. dl
Encs.

April 12, 1955

MEMO TO: L. E. Gregg
Assistant Director of Research

SUBJECT: Performance of Kentucky (Natural Sandstone)
Rock Asphalt

Since about 1948, the performance of natural rock asphalt, used extensively in Kentucky and Indiana, has been plagued by a unique type of scaling in the wheel tracks of each traffic lane. This scaling has been typically an eighth to a quarter of an inch thick and has left the pavements rough and unsightly. In some cases, this phenomenon has occurred several times in the same place and has caused much deeper rutting. The general condition is illustrated in a series of photographs attached hereto.

In 1950 the writer studied several hundred miles of rock asphalt re-surfacing in Indiana and found the condition to be very prevalent and similar in almost every respect to the failures observed on surfaces placed more recently. Construction records and laboratory records showed that the materials and construction procedures complied with all of the requirements specified; and insofar as these requirements were concerned, the materials that scaled were equal to those materials used in previous years and which had not scaled.

Logically, of course, some responsible property or component of the material was not accountable under the controlling specifications.

From the standpoint of occurrence, the scaling was most prevalent under conditions where moisture was most prevalent. Where there was poor drainage, and where the road was shaded by trees, etc. On some roads, scaling was encountered only at locations such as these. The conclusion then was that moisture was in some way a contributing influence to the scaling that resulted.

On examination of the scale, it was found that there was always a layer of "stripped" sand grains underneath, and there was no bond between the surface crust and the underlying material. Even where the crust was still in place, it was frequently possible to slide a thin blade under it and to displace long sections within the wheel tracks. By going transversely across the lane, it was found that the condition was confined to the wheel tracks. Accordingly, it was concluded that traffic was also a contributing factor; but that water accelerated the failure.

Before consideration is given to details of the problem, it should be pointed out that compacted rock asphalt has a unit weight ranging from 110 to 125 lbs. per. cu. ft., contains 6.2 to 9% asphalt, and has 15 to 20% voids. The sand is fairly uniform in size and is composed largely of angular quartz crystals. No consistency requirements, such as penetration, are specified for the natural bituminous binder. However, in the case of Processed Sandstone Rock Asphalt, containing not

less than 3% natural bitumen, additives of emulsified asphalt and asphalt cement are permitted; and these materials are controlled by physical tests. In other words, specifications used have not held any control over the quality and consistency of the natural asphalt. Some records show variations in penetration ranging from 15 to over 300.

In connection with the ensuing discussions covering the more general aspects of the problem, specific observations have been made on U. S. 421 at Midway, U. S. 27 from Lexington to Nicholasville, and U. S. 31 W between Munfordville and Cave City and also from its junction with U. S. 68 to Edmonson County. The results of these observations are contained in Fig. 1 through Fig. 24 at the back of this report.

In every case of scaling observed, the scale seemed to be a hardened crust. This might be explained entirely as a normal curing process characteristic of most rock asphalt surfaces if it were not for the fact that immediately below the stripped sand grains there was also a layer of harder asphalt, almost forming a membrane-seal over the material below. Apparently, part of the stripped asphalt migrated, or was carried, up into the surface layer and part downward. The asphalt in the crust and immediately below was not at all like the original asphalt or that down in the lower layer. Microscopic inspection revealed that this material was black and shiny; but the coating frequently did not cover all the sand surfaces. In contrast, the fresh material and even material from the lower layer had only an oily sheen covering parts of the sand surfaces and the remaining surfaces were usually coated with

black bitumen. In summary, the writer is of the opinion that these natural binders are not homogeneous asphalts, and there is probably more oil present than can exist in equilibrium with the heavier asphaltic bodies. The excess of oil is either easily emulsified or else it is easily saponified - either of these could cause the oil to strip and to separate from the heavier asphalt. To test the validity of this idea, a sample of rock asphalt was boiled in water containing a detergent; subsequent microscopic examination showed that the lighter oils had been readily dissolved away, leaving about half of the sand grains completely clean and the other grains either partly or completely coated with the harder asphalt. This washed sample looked very much like the material from the shoulder on 31 W (Fig. 13).

A logical concept of the scaling process is reconstructed and portrayed diagrammatically on the following page. In a saturated or inundated surface, highly porous; under traffic there would be high velocity currents and possibly very high hydrodynamic pressures under the wheels. Pressures in front of the wheels might even be considered as positive pressures and those behind be negative. Assuming that such a hydraulic gradient does exist and that the plane of high velocity current is parallel to the surface, the layer above is confined under the wheel and the layer below is confined from below on all sides; water in the lower layer is made more static by these restrictions; and the

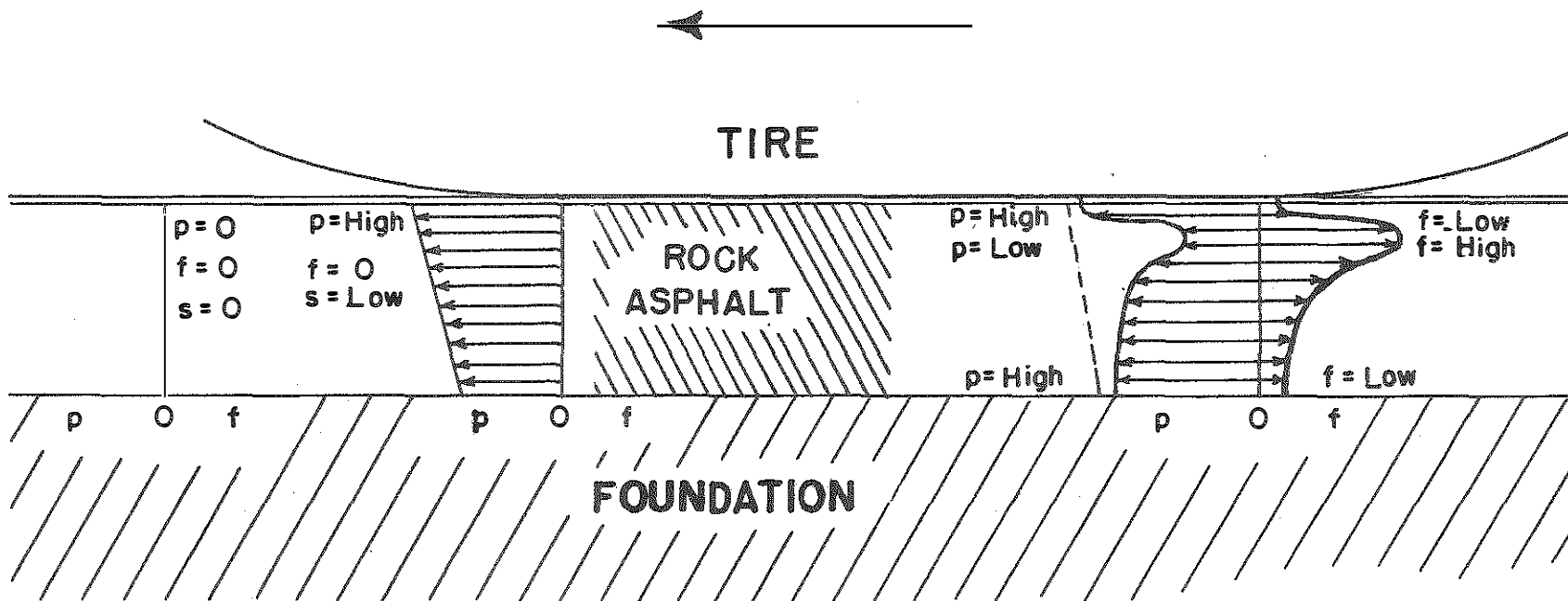

P - Hydrostatic Pressure
f - Flow of Water (Quantity)
s - Stress in Rock Asphalt

resultant or summation of these vectorial forces is near the surface and parallel to it. If the binding forces holding the bitumen onto the sand particles were strong enough to resist these hydro-dynamic forces, stripping could not occur.

Material that has not achieved a high degree of consolidation (high density) may have a tendency to be spongy under wheel loads and actually pump or squeeze water laterally through the pores. A material that is both damp and spongy could "shove" slightly in front of the wheel and produce a sheared plane which might not re-heal because of the moisture. An un-bonded surface layer would be free to flush water along in front of the wheel as portrayed in the second diagram.

There seems to be a rather critical period immediately following construction and extending through the first season which largely determines the success or failure of a paving job. In other words, it appears that if the conditions are favorable to curing and the asphalt is susceptible to curing, success may be assured; but apparently some of the materials used have been much too critical in this respect, and conditions may have been more favorable to stripping than to curing. Consequently, the life-expectancy of the material has been jeopardized. There is no doubt that rock asphalts have been and can be a high quality surfacing material. Pavements such as the one on 31 W north of the U. S. 68 junction demonstrate that fact. This tendency to strip and to require excessive curing is, therefore, indicative of abnormalities in the asphaltic binder.

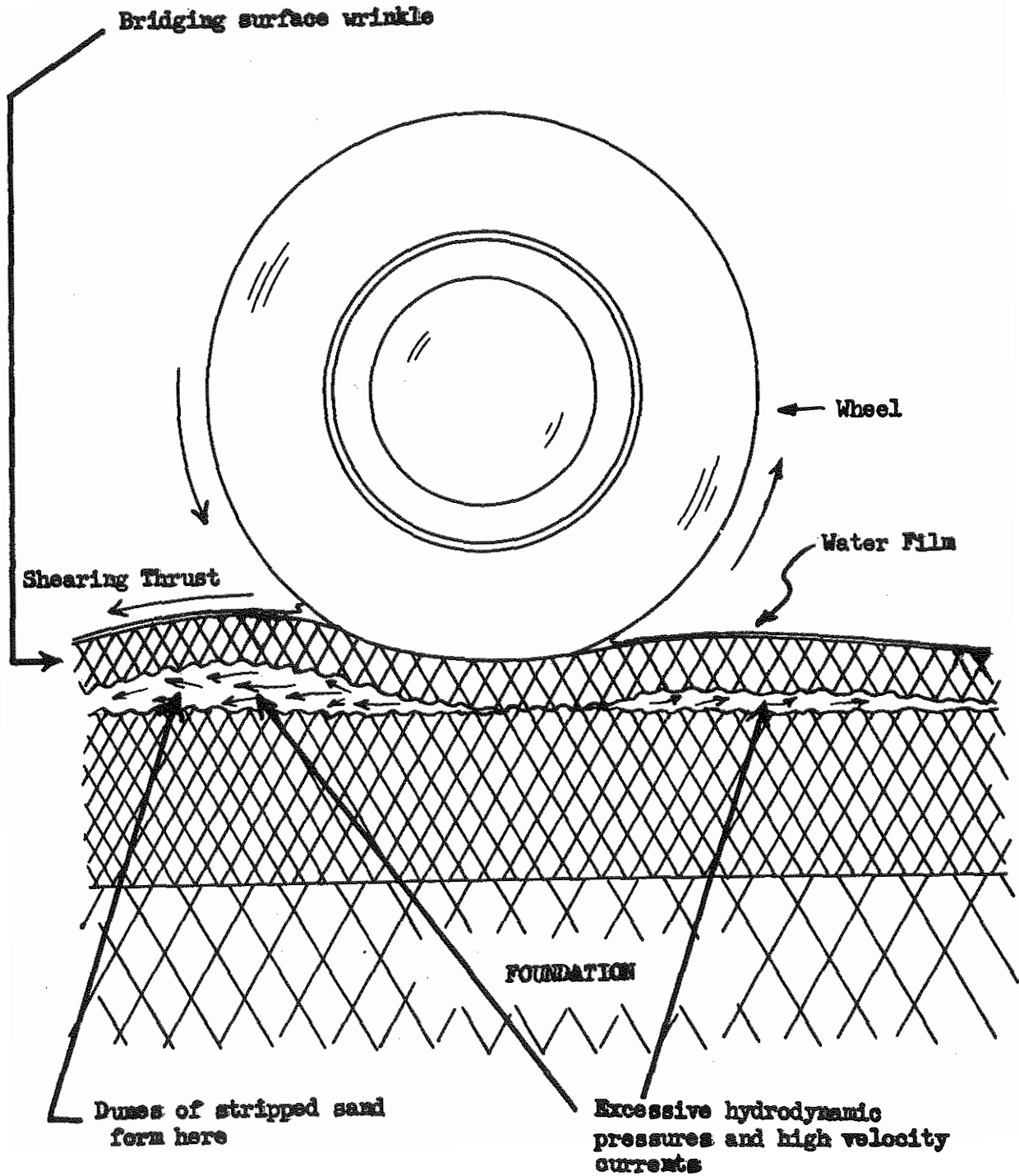

Prior to 1941, this type of failure was apparently not a very serious problem. However, a report* of an extensive investigation of the performance and properties of rock asphalts conducted by Purdue University in 1941 described a case of this type. About 1950 these failures became so critical in Indiana that the material was excluded from use on heavily traveled highways.

The study conducted at Purdue recognized the variations in consistency of the asphalt and differentiated them as "hard" and "soft", ranging from about 15 to 30 and to over 250 in their respective penetrations. Test data on material during the first year of service showed that soft asphalts having original penetrations in excess of 200 had cured to penetrations ranging from 50 to 80, and that 75% of this curing occurred during the first 30 days. Hard asphalts, over the same period showed little, if any, change. Stock-pile curing was found to be ineffective at depths greater than one inch. Curing on the road prior to rolling was found to be very effective in reducing moisture content, and the longer aeration period prior to compaction lowered the penetration of the soft material very slightly but significantly. The material that scaled was described as a soft, uncured, tunnel material of the Pottsville

Tyler, O. R.; Goetz, W. H.; and Slessor, C.; "Natural Sandstone Rock Asphalt", Engineering Bulletin, Research Series No. 78, Purdue University, 1941.

series. Quoting further from the report;

- "Inspection revealed that the sand grains were not uniformly coated, and large patches of the surface could be removed with the fingers. It is said that the material in this road was produced by tunneling followed by immediate stock-piling. This type of treatment does not allow orientation of the asphalt around the sand grains or the escape of any excess moisture. The southern three miles of this section seemed to be in better condition than the northern part, and information has been received that the southern part was laid in such a fashion as to allow a longer aeration period before compaction. The northern part of the job was machine laid and, accordingly, rolled considerably sooner." -

Consistency of the asphalt binder in rock asphalt is significant from several points of view, just as in any bituminous concrete. For instance, if stability is considered in terms of a friction factor and a cohesion factor, then cohesion is a measure of the forces holding the aggregate particles together and is consequently a measure of the consistency of the asphalt. In rock asphalt, the grading and shape of the sand particles is fairly constant; and the friction factor varies only with respect to the degree of consolidation and orientation of the particles. Ultimate stability can only be realized when maximum density of the sand (highest possible friction factor) is achieved with the "hardest" asphalt that will permit compaction and consolidation by practical procedures. Therefore, it seems logical to say that consistency of the asphalt determines the degree of consolidation that can be achieved and also stability and strength. Obviously, there should be an optimum range in binder consistency which would compromise workability with stability and strength.

In contemplating further study of the problem on the basis of the observations and the interpretations that have been presented, there is a need for more basic information and data pertaining to:

1. Relationships between asphalt consistency and maximum density by laboratory compaction, optimum temperatures for compaction, optimum asphalt contents and stability.
2. Properties of materials now in service and their relation to performance - including densities, asphalt contents, and asphalt consistencies.
3. Stripping tendencies of freshly quarried, stock-piled, and road-cured materials - including studies of the benefit that might be gained through the use of anti-stripping additives.
4. Constituent composition of "soft" and "hard" natural asphaltic binders - including determinations of asphaltenes, resins, and oils; saponification tendencies, and susceptibility to curing (thin film oven tests).

This type of information should lead to the establishment of definite requirement limits for binder consistency in terms of a conventional penetration grade.

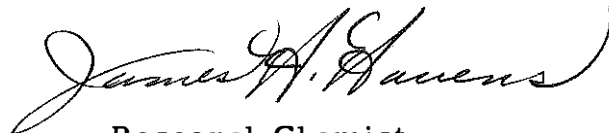

Research Chemist



Research Engineer



Fig. 1 - U. S. 421 near Midway showing where entrance was made through the crust with a thin blade, crust was easily lifted up revealing small sand pockets between the loosened crust and the lower layer. A scaled section in the wheel track of the left lane is visible, and in the foreground there are indications of wrinkling and shoving.



Fig. 2 - Close up of the section in Fig. 1 showing loosened crust and pockets of stripped sand. The surface was not broken here until this exposure was made. Crust contained 6.94% asphalt by extraction; 77°F Pen. - 36. Asphalt in the material underlying the crust seemed much softer.

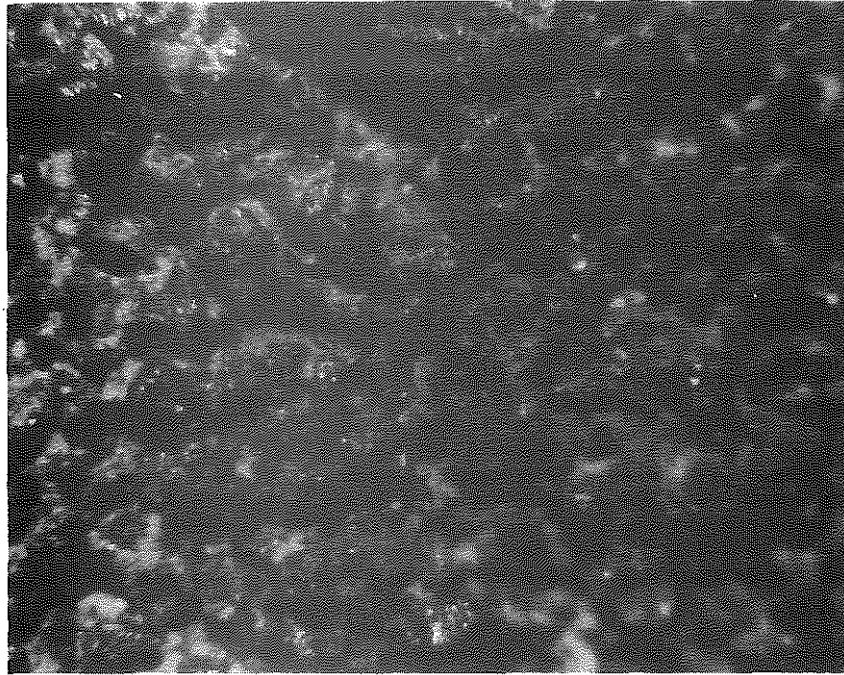

Fig. 3 - Photomicrograph showing the texture of the top surface of material removed from the location illustrated in Fig. 2. All the sand grains are well coated with asphalt.

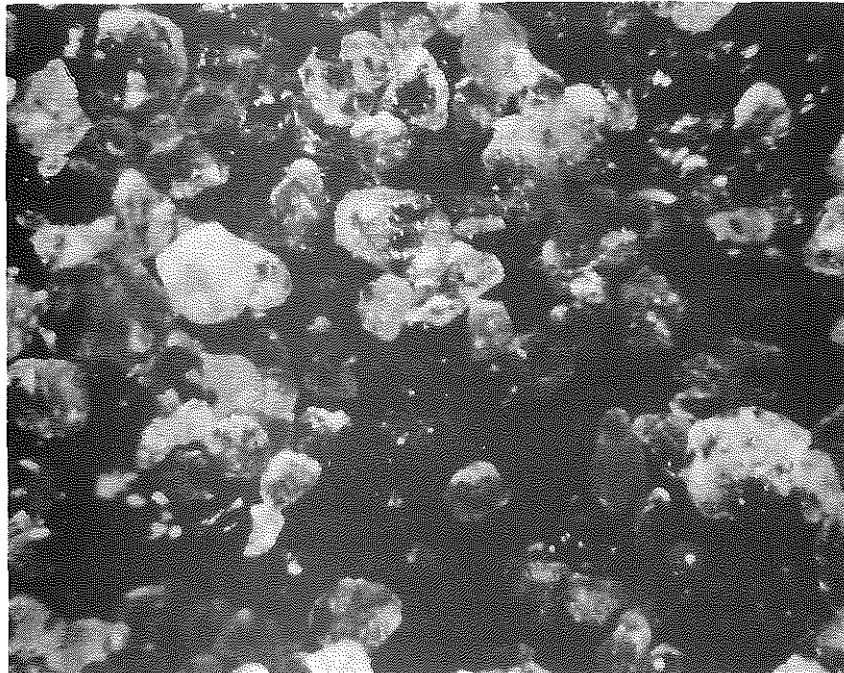

Fig. 4 - Photomicrograph of the lower side of the crust, showing stripped sand grains. The loose crust here was approximately $3/16''$ thick.



Fig. 5 - U. S. 27 south of Lexington, showing typical scaling in the outer wheel track of the left lane. On this road, these failures were very localized.



Fig. 6 - U. S. 27 south of Lexington showing where entrance was made through the crust near scaling in the wheel tracks.



Fig. 7 - U. S. 27, showing two close-up views of an opening in the crust and underlying pockets of stripped sand. Only in a few places was it possible to insert a blade in this manner.

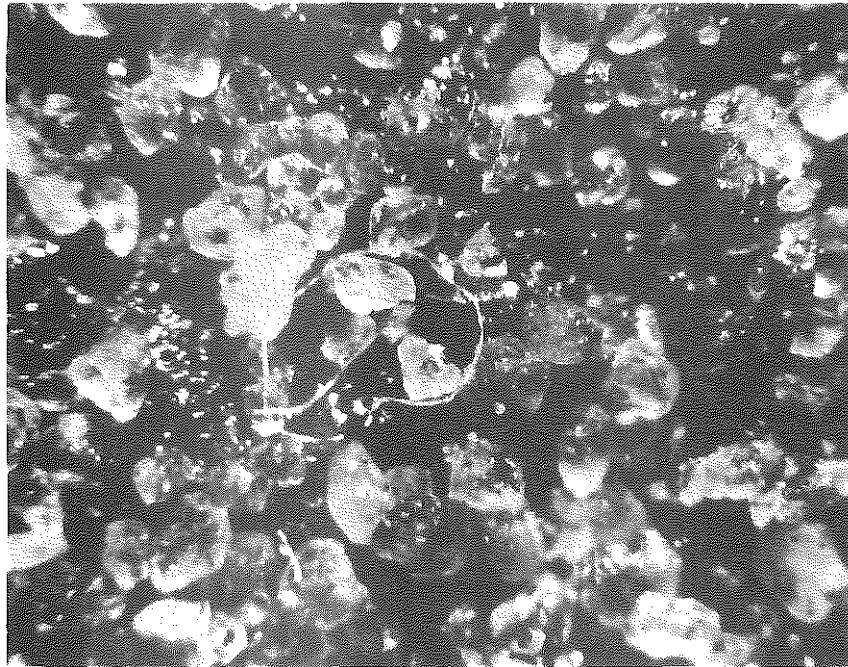

Fig. 8 - Photomicrograph showing stripped sand grains clinging to the lower side of the loosened crust.

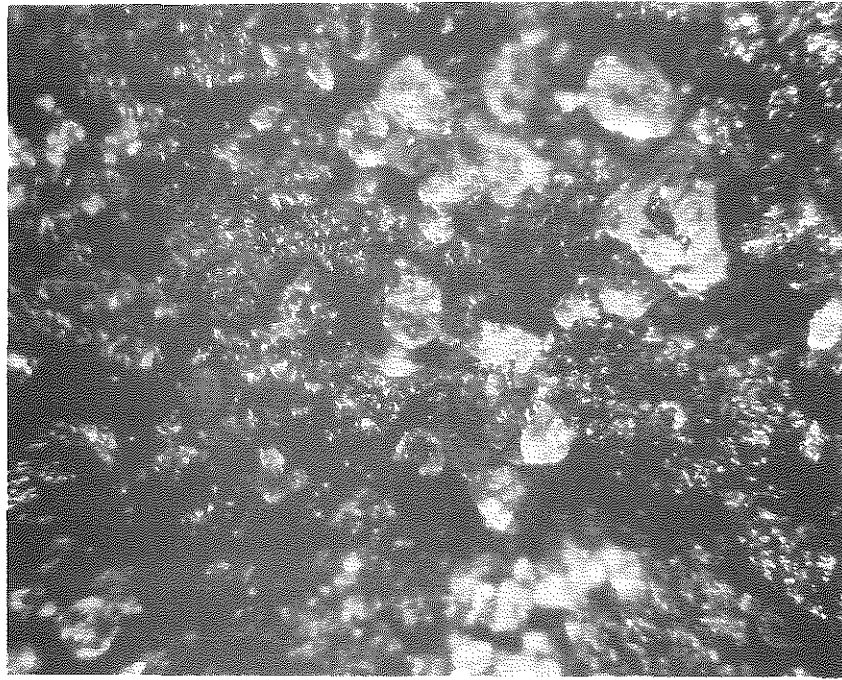

Fig. 9 - U. S. 27, Photomicrograph showing exposed surface after loose scale was removed. A few stripped sand grains are visible; but, for the most part, the particles are well coated.

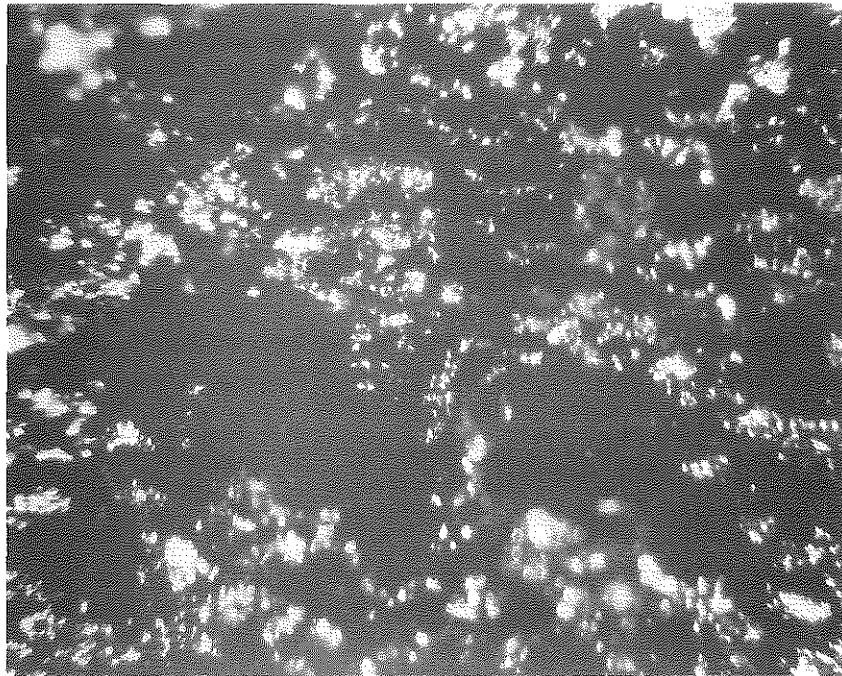

Fig. 10 - U. S. 27 Photomicrograph of a freshly broken cross-section of material taken from the lower layer. All the sand grains are fully coated, and light areas merely represent reflected light.



Fig. 11 - U. S. 31 W at Horse Cave. Extensive rutting has taken place in the wheel tracks throughout the entire length of the resurfacing project. Traffic is now riding on the binder course. The failure here began in much the same manner as in other cases but it seems to have progressed more rapidly. Most of the original material has been thrown onto the shoulder where apparently it is of some value as a stabilizer. The binder where exposed, has the appearance of a very nice surface course.

An opening was made at the edge of the pavement just north of Horse Cave where drainage conditions seemed rather poor. There were no indications of water in the binder or the underlying, older rock asphalt surface. Below the older rock asphalt was a course that appeared to be a black base: it was dry and solid. There was a concrete curb that prevented any deeper excavation. A small chisel was driven through the binder in the middle of the inside wheel track and there were no indications of moisture in the dust of the crushed aggregate.

The rock asphalt that remains on the road is poorly consolidated; slightly damp in places; shows indications of having been shoved and re-arranged, loosened, and recompact: and a blade was easily inserted through the full depth of the rock asphalt course. Apparently stripping has not been confined to any particular level or location within the traffic zone. So much stripping has occurred, the material looks gray rather than black.

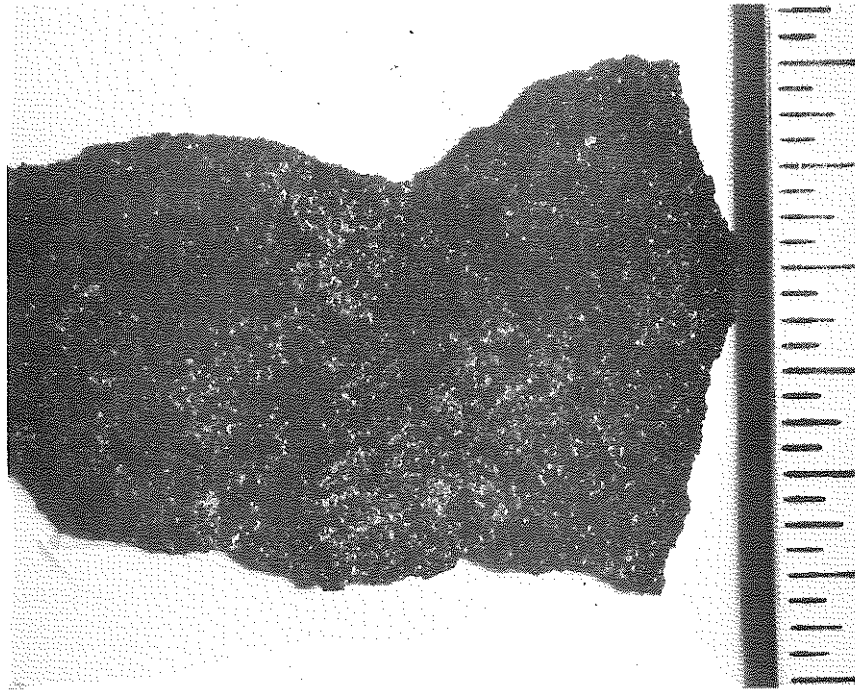

Fig. 23 - U. S. 52, Photograph of the lower side of scale taken from the location shown in Fig. 22, revealing stripped sand.

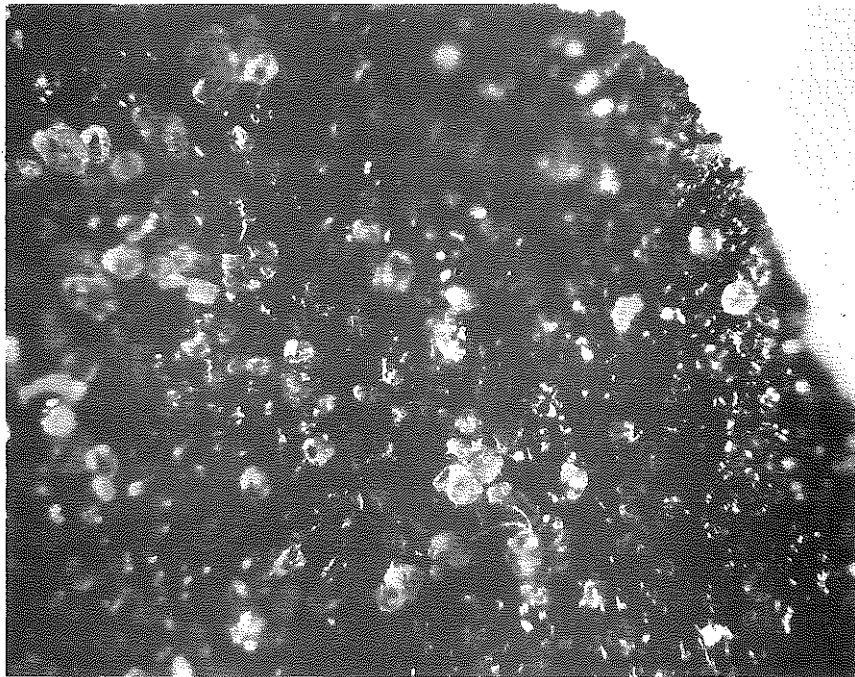

Fig. 24 - U.S. 52, Photomicrograph of the lower side of loosened scale showing un-coated, stripped, sand.