

DISCUSSION ON SKID RESISTANCE
OF PAVEMENT SURFACES

by

R. L. Rizenbergs
Principal Research Engineer

Division of Research
Kentucky Department of Highways

September 1968

TABLE OF CONTENTS

	Page
INTRODUCTION	1
THEORETICAL CONSIDERATIONS	1
Classical Laws	
Rubber Friction	
Sliding Velocity	
Temperature	
Normal Pressure	
MECHANISM OF FRICTION	4
Shear	
Hysteresis	
Variables Affecting Rubber Friction	
Sliding Velocity	
Temperature	
Normal Pressure	
Lubrication	
MODES OF TIRE OPERATION	10
Sliding or Skidding	
Braking	
Cornering	
Acceleration	
RUBBER AND TIRE PROPERTIES	13
PAVEMENT SURFACE PROPERTIES	13
Affecting Factors	
Lubrication and Hydroplaning	
Seasons	
Drought	
Traffic	
Longitudinal and Transverse Variation in Friction	
ROAD FRICTION MEASUREMENT	20
Automobiles	
Trailers	
Portable Tester	
Tester Comparison	

TABLE OF CONTENTS (CONT'D)

	Page
SKID TESTER CORRELATION	25
Trailers vs Automobiles (Ky)	
Automobiles vs Drag Tester	
Drag Tester vs Trailer	
SKID RESISTANCE REQUIREMENTS	27
REFERENCES	31

INTRODUCTION

The concern for adequate skid resistance or friction of pavement surfaces is confined to wet weather conditions. Dry pavements are highly skid resistant unless the surface contains loose material, such as gravel, sand, etc., which could provide rolling action by the particles under the tires. Surface contaminants, such as oil, soft tars and asphalt, etc., could also provide lubrication to the surface and create a slippery condition. Normally, however, water is the lubricating agent reducing pavement friction and in some cases creating very hazardous driving conditions. Another situation of concern is drainage, or lack of proper drainage, of the pavement. Excessive water depth may cause the vehicle tires to hydroplane, i.e., the tires may become separated from the surface and ride partially or entirely on a water layer, thus causing loss of traction. Both of these conditions will be discussed in detail.

THEORETICAL CONSIDERATIONS

Classical Laws

A discussion of classical laws of dry friction between solid bodies may be found in any good physics book and will not be dealt with here in any detail. It may be useful, however, to review the basic principles involved.

Static Friction - The maximum force of static friction between two surfaces is proportional to the normal force between the surfaces. The coefficient of proportionality, f_s , depends on the material and roughness of the surfaces, but, over a wide range, is independent of area of contact between the surfaces. That is

$$F_s = f_s N \quad 1$$

where F_s = maximum static friction force,

f_s = proportionality constant or coefficient of static friction, and

N = normal force or load.

Kinetic Friction - The force of kinetic friction between two surfaces is proportional to the normal force between the surfaces. The proportionality constant, f_k , depends on the material and roughness of the surfaces but, over a wide range, is independent of the area of contact of the surfaces and of the relative velocity of the surfaces (Refer to Figure 1), or

$$F_k = f_k N \quad 2$$

where F_k = kinetic friction force,

f_k = proportionality constant or coefficient of kinetic friction, and

N = normal force or load.

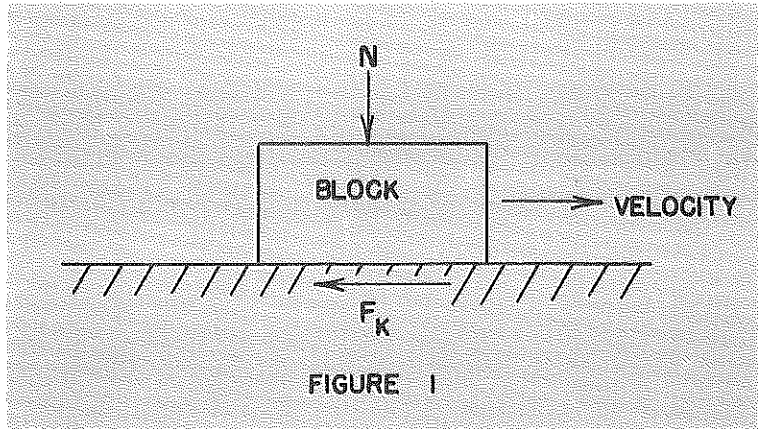

The classical laws therefore state that the coefficient of friction is independent of the normal load, the apparent contact area, the sliding velocity and temperature. The first law can be restated to mean that the coefficient of friction is independent of normal pressure.

Equation 2 implies that the friction force developed between two surfaces in motion can be equal to the normal force or load. The coefficient of friction therefore cannot be greater than unity (1.0). In real life, conditions can exist where this may be not true. For all practical purposes, it will be assumed that the coefficient will be less than unity.

Rubber Friction

Unfortunately, most materials, especially viscoelastic materials such as rubber, do not obey these classical laws. Neither do they pertain to conditions where lubricating agents have been introduced between the surfaces. The friction between pavement surfaces and tires is very much dependent upon velocity and to a lesser extent upon normal pressure and temperature. This discussion will be directed exclusively towards kinetic friction since we are concerned only with what is happening to a vehicle in motion.

Sliding Velocity - The dependence of the coefficient of friction upon velocity between a skidding tire and the pavement is illustrated in Figure 2. All pavement surfaces exhibit lower friction with increase in vehicle velocity. The slopes of the curves, however, differ and are dictated by the texture characteristics of the surface and material composition of the pavement and tire rubber. A more detailed discussion on this subject will be undertaken later.

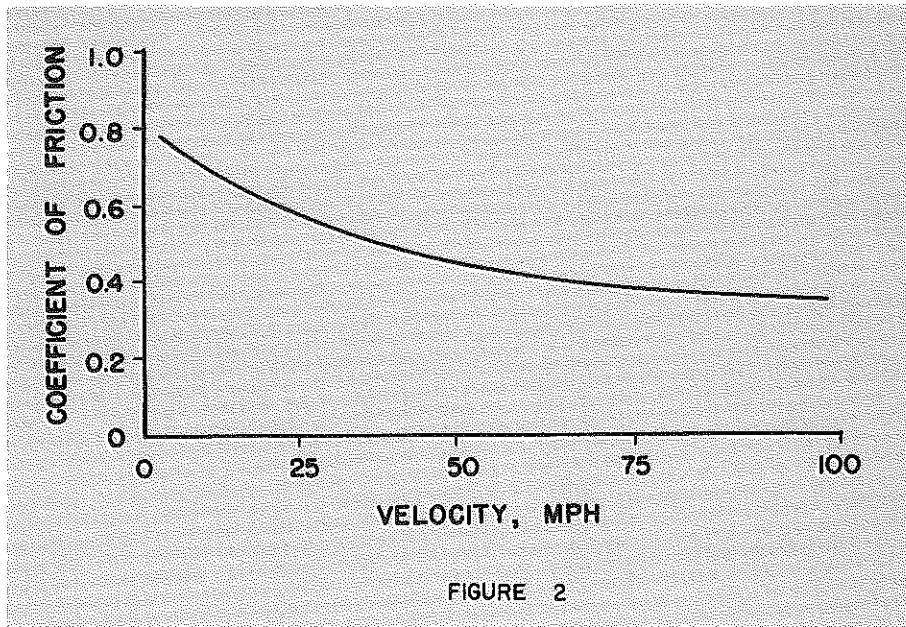

Temperature - Temperature affects friction in a manner shown in Figure 3. Again texture of the pavement determines the extent to which the coefficient will change with temperature at a given velocity. As the velocity is varied, the temperature effects will be altered. The composition of rubber and the design characteristics of the tire itself will play an important role.

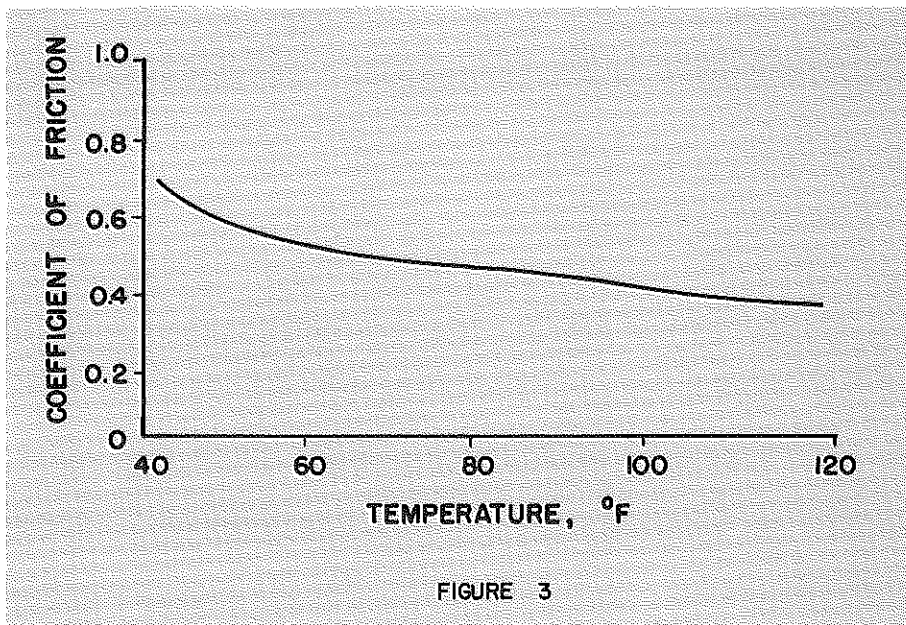

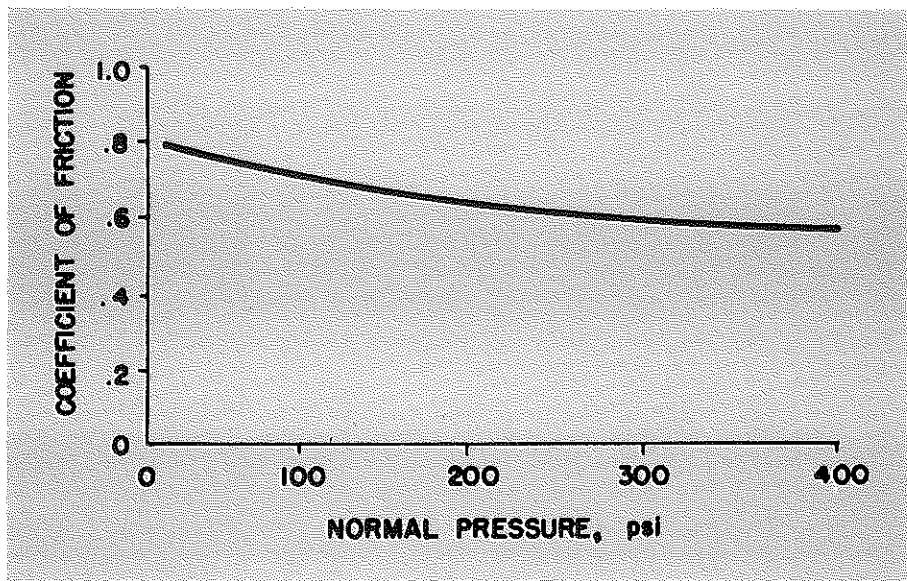

FIGURE 4

Normal Pressure - Figure 4 illustrates the friction characteristics of rubber tires with changes in normal pressure at the tire-pavement interface. The decrease of friction with increase in normal pressure again is dependent upon velocity and Figure 4 pertains to a given pavement surface and tire for a single velocity. The reduction in f is due to a less rapid increase of the actual contact area between rubber at the tire and pavement interface as the normal pressure is increased.

MECHANISM OF FRICTION

Friction may be regarded phenomenologically - that is, it can be observed and measured, but not fully explained. Theories have been offered to at least partially explain some of the mechanisms involved. These explanations, however, have not met universal acceptance.

When the rubber elements of a tire are sliding on a pavement surface, a resistive force is developed at the plane of contact. This force may be due to a single component such as shear. Generally, several discrete components or mechanisms act simultaneously to generate the prevailing friction. Hysteresis of the rubber, viscous drag of the lubricant, and other lesser mechanisms contribute. The discussion here will be limited to two principal friction components - shear and hysteresis.

Shear

Figure 5 shows a single asperity, such as a sand particle, penetrating into the rubber element of the tire. Due to the quasielastic behavior of rubber under compression, high normal pressures (up to 1000 psi) are developed between the particle and the rubber.

The horizontal component can be described by

$$F_{Ai} = SA_i \quad 3$$

where A_i = projection of enveloped surface (equals actual contact area) and
 S = shear strength.

The summation of these components over the entire surface (n particles) will give the shear component

$$F_A = S \sum_1^n A_i. \quad 4$$

The shear component can be increased considerably by mating a smooth-tread tire with a well-polished, smooth pavement, provided the surface is clean and dry. However, this pairing is extremely dangerous when water is present.

Hysteresis

Figure 5 illustrates on the same sand particle the mechanism that is responsible for the hysteresis component, F_H . When the rubber block is moved, it must climb over the particle and is subjected to deformation. The deformation consists of a compression phase on the left side of the particle and an expansion phase on the right side. To compress the rubber at the left, an energy quantum, E_{Ci} , is required. It is the sum of the product of the compression force normal to the particle surface times the displacement in the force direction. Rubber does not return completely the received energy E_{Ci} but only E_{ei} . The difference between the compression energy and the expansion energy, $(E_c - E_e)_i$, is lost to the rubber and is dissipated in the form of heat. This loss must be compensated by an outside force F_{Hc} acting in the direction of motion in the rubber element.

The force F_{Hi} due to the single particle being considered here is proportional to energy difference,

$$F_{Hi} = C(E_c - E_e)_i, \quad 5$$

and when summed over the entire contact area (n particles), the total resistance due to hysteresis is

$$F_H = C \sum_1^n (E_c - E_e)_i. \quad 6$$

By combining Equations 4 and 6 the resultant force is found to be

$$F = \sum_1^n SA_i + C \sum_1^n (E_c - E_e)_i. \quad 7$$

Forces arising from other contributing mechanisms or interactions at the tire-pavement interface, as stated before, would be added to Equation 7. It should be recognized that, in measuring friction, the combined frictional force is obtained and there is no precise way by which to determine the extent to which each friction component contributes.

Variables Affecting Rubber Friction

The mechanisms responsible for the shear and hysteresis components are quite different. Consequently, the influencing factors of normal pressures, sliding velocity, temperature and lubrication cannot be expected to affect each component in the same manner. Inspection of each variable, in fact, must be coupled with the understanding that the tire rubber characteristics, texture of the pavement, and the materials composing the pavement surface will determine the relative magnitude of the shear and hysteresis components. The graphs which are to follow should be viewed strictly as illustrations and should not be regarded as typical characteristics of highway surfaces in Kentucky.

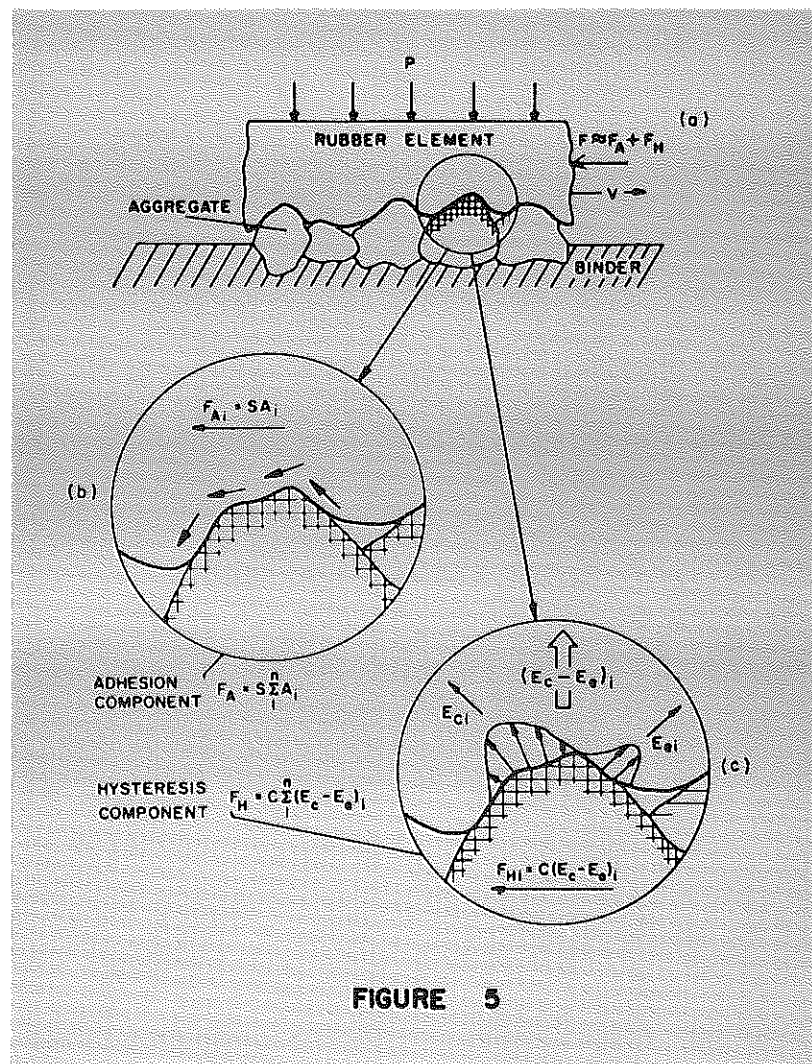

Sliding Velocity - Figure 6 illustrates the effects of sliding velocity. The shear component decreases with increase in speed. This is caused by the "slip-stick" phenomena and, to a lesser extent, by accompanying temperature changes at the tire-pavement interface. The higher the velocity, the higher will be the interface temperature, and, as we have seen in Figure 3, friction tends to decrease with increase in temperature. Also, as the roughness of the surface increases, the greater will be the temperature change for a given velocity. It is difficult, therefore, to say whether f_A in Figure 6 is influenced primarily by velocity or by the accompanying changes in temperature.

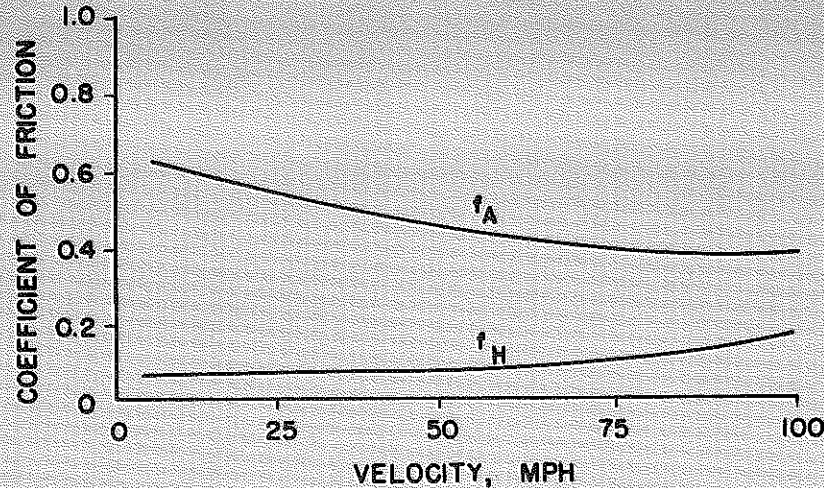

FIGURE 6

The increase in f_H with speed is caused by the increased rate of deformation of rubber, even though the deformation amplitude will decrease with speed due to increased stiffness of the rubber.

Temperature - Figure 7 shows that both friction components decrease with increase in temperature. This would seem reasonable since both mechanisms are molecular in nature and any molecular motion increases with temperature. Rubber molecules disturbed by deformation will return more readily, with lower internal losses, to their initial positions when the temperature is greater, thus accounting for the drop in f_H . This generalization does not hold true in many cases. In fact, the friction-temperature gradient (slope) may be larger or smaller, positive, zero, or negative. The sign of the gradient depends primarily on sliding speed, water depth, and air and tire temperatures. The magnitude of the gradient is largely a function of damping and elasticity of rubber and texture or roughness of the pavement surface. Constant slip testers (such as the Drag Tester) operate at low test speeds. A negative temperature gradient will result below 100°F while a positive gradient will result above 100°F. The gradient should reduce with decreasing surface roughness and increasing wet-pavement temperature. For other skid testers the gradient will most likely be negative

and its magnitude can be expected to decrease with decreasing surface roughness and increasing temperature.

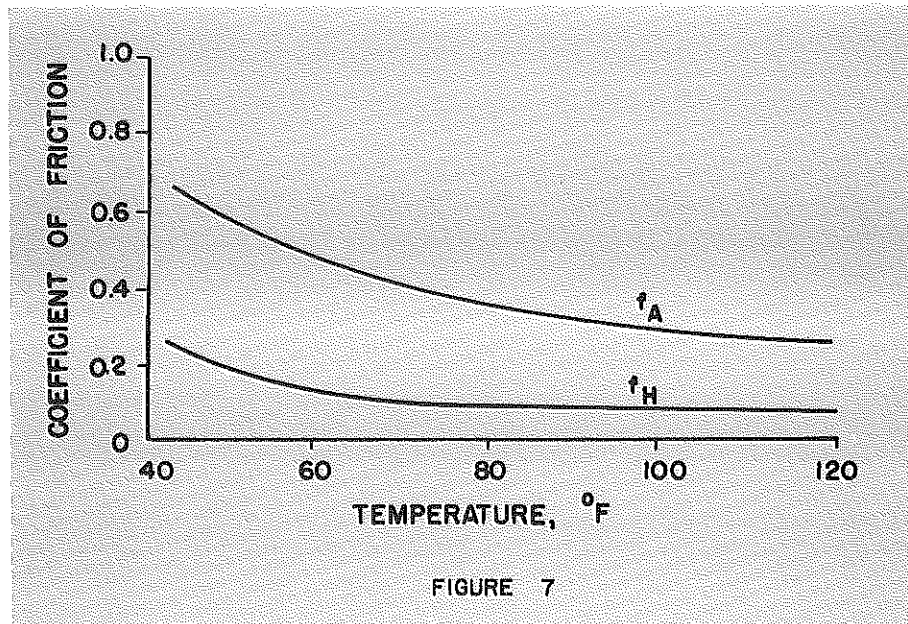

FIGURE 7

Normal Pressure - It has been seen in Figure 4 how the sliding coefficient is dependent upon normal pressures. The graph is redrawn in Figure 8 to show the effects of normal pressure changes on f_A and f_H .

If the load on a tire is increased, the friction developed by the sliding tire is less sensitive to the load changes than would be expected. The explanation is that as the load is increased the tire-print area also increases with correspondingly small changes in the normal pressures that act on the rubber elements in the contact area. Figure 9 shows the changes in normal pressures under the tire print at two locations in the contact area while the tire pressure remains constant. As the wheel load is increased, local pressures at the outer ribs of the tire increase because bending of the carcass has become more severe. It will also produce creep and sliding of the tread elements in the contact area. Pressures at the center of the contact area are affected only slightly because the ribs behave like a membrane and pressures in the zone can be altered only by changing the tire inflation pressure.

If the wheel load is constant and the tire inflation pressure is increased (Figure 10), the contact area decreases. The load carried by the tread elements in the center of the contact area increases linearly with increased inflation pressure. The pressure under the outer ribs experiences a slight decrease. The net effect is an increase in normal pressure.

Shear and hysteresis are affected differently by changes in contact pressures. The shear components decreases while the hysteresis component increases with pressure. Therefore, changes in either will partially balance

FIGURE 9

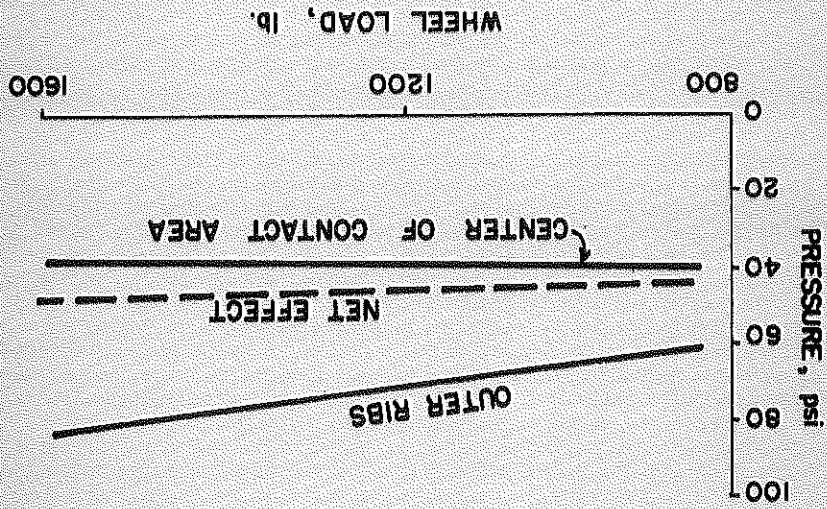
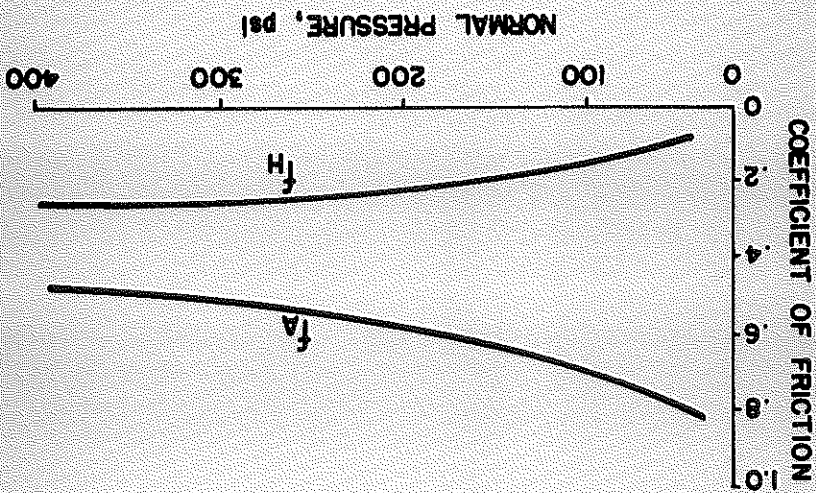

FIGURE 8



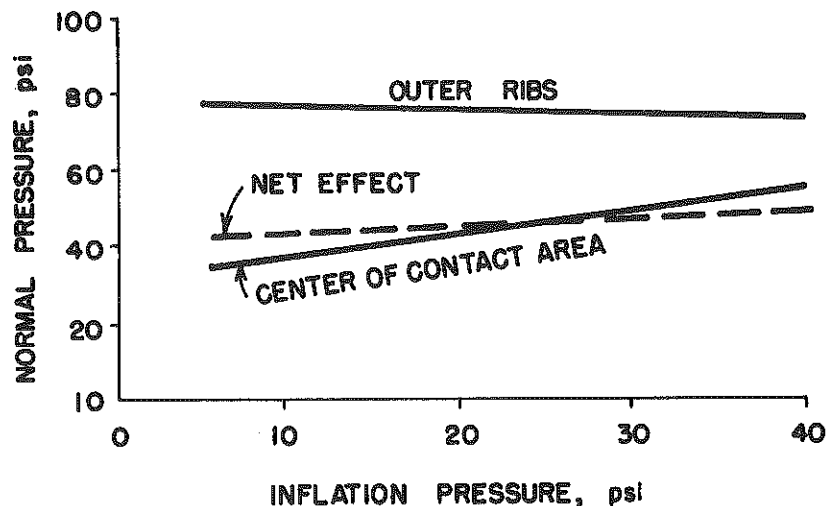

FIGURE 10

each other. Here again the texture of the pavement will govern the magnitude of each component.

Lubrication - Introduction of water as a lubricating agent on pavement surfaces significantly reduces friction. The loss of friction is attributable to a reduction in the shear component since the shear strength of the bond between rubber and pavement is affected. Hysteresis, on the other hand, is largely unaffected since it depends on the rate and magnitude of rubber deformation. In fact f_H may have a slight tendency to increase because frictional heating due to shear is reduced as a result of heat dissipation by water in the contact area, thus resulting in a lower temperature of the rubber.

MODES OF TIRE OPERATION

Normally a vehicle on the highway is subjected to acceleration, braking, turning and cornering maneuvers. Skidding occurs only when the driver is confronted with a hazardous situation or when he has misjudged the frictional level of the pavement in exercising driving maneuvers. In normal driving, therefore, the vehicle operates in the slip mode. Each of the modes of tire operation shall be examined.

Sliding or Skidding

Sliding, from the standpoint of frictional behavior of a tire when the wheels are locked, represents a relatively simple situation. There is little motion of the tire elements within the contact area. Figure 11 illustrates the sliding coefficient on a pavement surface under dry and wet conditions as the velocity is changed. Dry friction is higher than when the pavement is wet.

The friction gradients and the magnitudes of friction are different, and both depend on the degree of pavement polishing and surface texture. In dry conditions the decay in friction is due to slip-stick and temperature and the reduction becomes more severe when the decomposition temperature of the rubber is reached. In other words, rubber melting takes place. This is evidenced by black skid marks left by skidding or accelerating vehicles. When the pavement is wetted, decrease in friction is more pronounced and depends primarily on surface texture, tread design of the tire, and water depth. Temperature effects are secondary but the increasing hydrodynamic lift imparted to the tire by a layer of water significantly reduces shear at higher velocities. A detailed discussion of hydrodynamic lift and hydroplaning will be offered in a separate section.

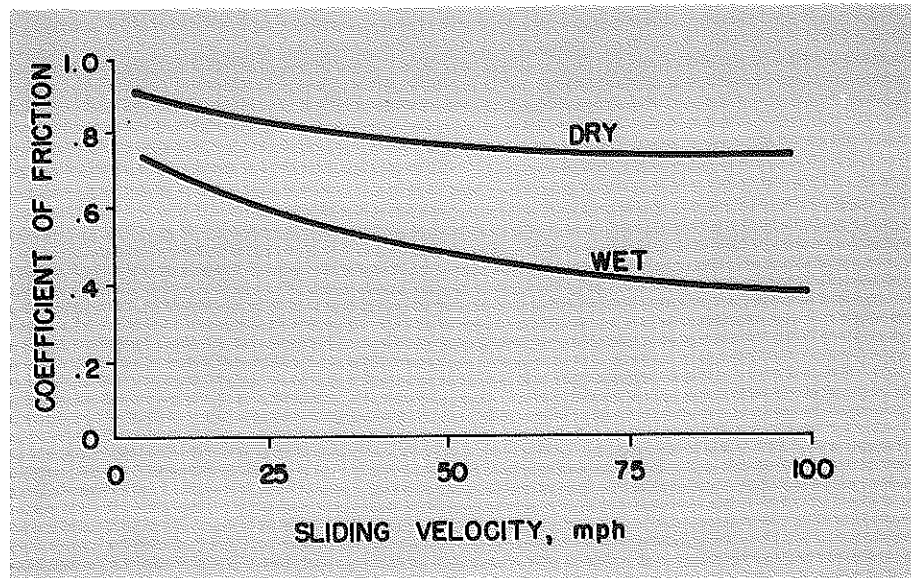

FIGURE II

In discussions of skidding vehicles, reference is usually made to a condition where, for one reason or another, the driver has attempted to decelerate quickly, and, in the process of doing so, has locked the wheels. If the deceleration of a skidding vehicle is monitored, a friction-velocity relationship similar to that shown in Figure 11 would be obtained. This is referred to as a non-steady-state skidding condition. It is non-steady state because velocity is continuously changing. Accompanying the velocity change, temperature at the tire-pavement interface is also continually changing. A condition of steady-state sliding would occur if a vehicle, with its wheels locked, would be pushed or pulled by another vehicle. Such a situation rarely occurs on the highway. The term is introduced at this point to contrast it with non-steady-state skidding and because most prevalent skid testing devices (trailers) operate in the steady-state sliding mode. Further discussion of this will be given in the section on skid testing devices.

Braking

In the process of braking and decelerating, a flexible pneumatic tire slips as it transmits force to the pavement. Slip is the ratio of the effective

slip velocity in a specific direction to the forward ground speed of the vehicle. The direction is forward in braking, backward in driving and accelerating, and sideways in cornering.

In braking,

$$S = (V_v - V_t)/V_t$$

where S = percent slip,

V_v = vehicle speed, and

V_t = forward velocity of the tire.

Figure 12 shows typical curves of slip resistance as a function of wheel slip during braking. The resistance increases linearly with a slip from zero to a maximum value. This value is generally referred to as incipient friction. The coefficient developed from zero to critical slip at incipient friction depends only upon the carcass stiffness and tread compound. It is not influenced by the limiting friction between rubber and surface. Tires develop incipient friction between 8 and 20 percent of slip. When critical slip is exceeded, the equilibrium between brake torque and road is generally disturbed and the wheel quickly decelerates and locks.

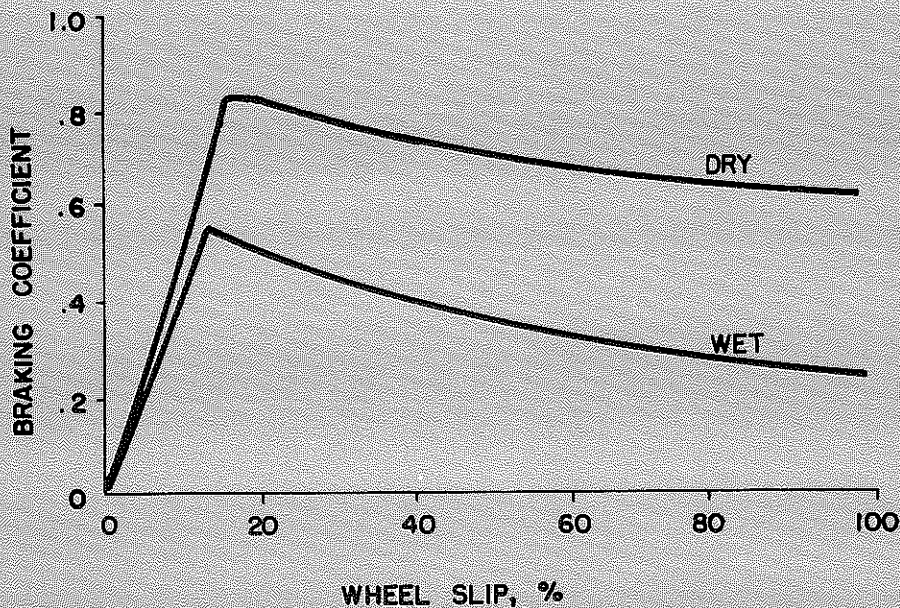

FIGURE 12

Cornering

Cornering is quite similar to the braking characteristics of tires. A separate discussion is not warranted.

Acceleration

While a vehicle is being accelerated, force is being transmitted to the pavement, thus causing the tires to slip. The degree of slippage depends upon the force being transmitted and the characteristics of the pavement surface and tire. Here the velocity of the vehicle is always less than the velocity of the tire. Again, like in braking, a certain percent of slip can be realized and traction in excess of the limiting friction between rubber and surface can be generated. Once the critical slip is reached, the wheel will quickly accelerate and begin to spin, imparting to the pavement a lesser tractional force.

RUBBER AND TIRE PROPERTIES

Tractional characteristics of tires differ widely. The tire properties are determined by tire structure, tread thickness and pattern, and rubber. Rubber properties are determined by composition, curing process and aging in service.

The dynamic properties of rubber have the most influence on friction performance. Static properties do not relate significantly with friction. The relationship between rubber properties and friction performance can be determined from hysteresis or damping losses of rubber. Changes in the hysteresis characteristics affect the rubber friction only. However, changes in rubber properties that influence the hysteresis loss may also change the shear characteristics. The damping losses of rubber are strongly dependent upon the frequency and amplitude of repetitive deformation and temperature of the rubber in the contact area of the sliding tire. The frequency Z may be defined as

$$Z = 1.47nV$$

where n = statistical number of discrete particles per square foot and

V = sliding velocity in mph.

The resultant frequency can be quite high (kilocycle range). Synthetic rubber develops maximum damping at about 1000 cps. Peak damping decreases with increase in temperature and causes frequency to increase. It follows then that for a given rubber composition maximum friction could be developed if the peak damping frequency is known. By providing an appropriate surface texture and velocity combination, the desired frequency Z could be obtained. Heat conductivity properties of the rubber play an important role in dictating the magnitude of the friction components. Rubber compounds that have high heat conductivity will produce greater hysteresis loss since the operating temperature is lower. On the other hand, rubber with lower heat conductivity will maintain higher operating temperatures and may even cause the rubber to melt.

Cornering

Cornering is quite similar to the braking characteristics of tires. A separate discussion is not warranted.

Acceleration

While a vehicle is being accelerated, force is being transmitted to the pavement, thus causing the tires to slip. The degree of slippage depends upon the force being transmitted and the characteristics of the pavement surface and tire. Here the velocity of the vehicle is always less than the velocity of the tire. Again, like in braking, a certain percent of slip can be realized and traction in excess of the limiting friction between rubber and surface can be generated. Once the critical slip is reached, the wheel will quickly accelerate and begin to spin, imparting to the pavement a lesser tractional force.

RUBBER AND TIRE PROPERTIES

Tractional characteristics of tires differ widely. The tire properties are determined by tire structure, tread thickness and pattern, and rubber. Rubber properties are determined by composition, curing process and aging in service.

The dynamic properties of rubber have the most influence on friction performance. Static properties do not relate significantly with friction. The relationship between rubber properties and friction performance can be determined from hysteresis or damping losses of rubber. Changes in the hysteresis characteristics affect the rubber friction only. However, changes in rubber properties that influence the hysteresis loss may also change the shear characteristics. The damping losses of rubber are strongly dependent upon the frequency and amplitude of repetitive deformation and temperature of the rubber in the contact area of the sliding tire. The frequency Z may be defined as

$$Z = 1.47nV$$

where n = statistical number of discrete particles per square foot and

V = sliding velocity in mph.

The resultant frequency can be quite high (kilocycle range). Synthetic rubber develops maximum damping at about 1000 cps. Peak damping decreases with increase in temperature and causes frequency to increase. It follows then that for a given rubber composition maximum friction could be developed if the peak damping frequency is known. By providing an appropriate surface texture and velocity combination, the desired frequency Z could be obtained. Heat conductivity properties of the rubber play an important role in dictating the magnitude of the friction components. Rubber compounds that have high heat conductivity will produce greater hysteresis loss since the operating temperature is lower. On the other hand, rubber with lower heat conductivity will maintain higher operating temperatures and may even cause the rubber to melt.

PAVEMENT SURFACE PROPERTIES

Pavement texture, both macroscopic and microscopic, and the molecular and drainage properties of a road surface determine to a large extent the obtainable friction in any mode of vehicle operation. Three parameters describe the textural characteristics of a surface:

1. The average number of discrete particles per unit area,
2. The average size of the particles, and
3. The average shape of the particles.

In dry conditions every pavement surface provides adequate skid resistance and, as stated before, polished or smooth surfaces yield the highest coefficients. A pavement, however, must be designed for wet conditions. The presence of water, especially when it is contaminated by inorganic or organic matter, significantly reduces friction between tire and pavement.

In the design of surface courses and surface treatments several requirements must be satisfied in order to insure adequate skid resistance:

1. Select aggregates that are highly polish resistant to insure preservation of particle shape for the longest possible time in service.
2. Select binder material that will wear and weather faster than aggregates to permit continuous aggregate exposure and surface wear.
3. Select the shape and size of aggregate which will permit the largest possible contact area between particles and tire where the local pressures are sufficient to penetrate water film and establish quasi-dry contact.
4. Select the materials for aggregate and binder with the highest surface tension with respect to water and tire rubber.
5. In the case of bituminous surface courses, specify a density of the mix which will insure significant void content to give the surface a somewhat open texture in order to insure alleviation of hydrostatic pressures under the tire.

In Kentucky, the coarse aggregates used in bituminous surface mixes have often been limestones. Most of these limestones are soft and are highly susceptible to polishing. To insure high skid resistance, it is necessary to be highly selective in choosing suitable limestones or utilize other materials which are polish resistant. Many surfaces are not providing the service life for which they have been designed simply because their skid resistance is inadequate.

Affecting Factors

Lubrication and Hydroplaning - Water as a lubricant between the tire and pavement was discussed before in connection with variables affecting

rubber friction. The attempt here will be to focus attention on what happens when the depth of water on a surface is increased and other factors play an important role in reducing friction.

Introduction of a thin layer or film of water on a pavement provides lubricating action at the tire-pavement interface. The shear strength between rubber and asperities is reduced and friction decreases. The decrease is primarily a function of sharpness and number of discrete particles which establish a quasi-dry contact. Even in this situation a pavement must have some roughness or texture to permit the tire to drape the particles and to dissipate locally generated hydrostatic pressures through minute drainage channels in the surface. As the thickness of the water layer is increased, greater quantities of water become entrapped and hydrostatic pressures rise since a lesser proportion of the water will find escape routes. The entrapped water will lend support to the rubber elements, thus reducing the load supported by the asperities. Local pressures at the asperities will be reduced. The displaced water will either be channeled through the texture of the surface or wiped aside or in front of the tire. In front of the tire a wedge of water will be developed which will lift the rubber element from the pavement.

Figure 13 shows the manner in which a tire will behave under these conditions. The proportion of the upward thrust and sinkage zone under the tire is dependent upon the thickness of the water layer, texture of the pavement, tread depth inflation pressure of the tire, and velocity of the vehicle. As the vehicle speed is increased, time available for water displacement is reduced due to the inertia of the water. In the case of a rolling tire, the time of squeezing action of a particular tread element entering the contact length exceeds the time of traversal of the element through the contact area; there is no draping of actual contact made. This condition is referred to as hydroplaning. If all rubber elements are behaving similarly, a condition of total hydroplaning exists and the driver loses control of the vehicle. The vehicle will experience some speed reduction primarily due to air resistance on the vehicle and eventually the tires again will contact the surface at a reduced velocity. The major factor influencing the time of squeezing is the nature of the surface roughness, while both surface roughness and dynamic properties of rubber determine the time of draping.

Total hydroplaning may occur whether the tire is rolling or sliding. For every set of wet pavement conditions there are two critical velocities called the hydroplaning limit in rolling and hydroplaning limit in sliding. The hydroplaning limit in sliding occurs at much lower velocities than the rolling situations. Sudden application of brakes, therefore, may cause tires to hydroplane. If hydroplaning in driving is experienced, application of brakes will prolong the distance in which the tires will hydroplane.

Partial hydroplaning contributes to decrease in friction with increased velocity whenever the water depth exceeds about 0.15 inches, but the influence is not significant when compared to other mechanisms responsible for reduction in friction. Water depth of about 0.5 inches or greater may be required on a smooth textured surface to provide total hydroplaning at low velocities, provided the vehicle tires are also smooth or well worn. Here the velocity of hydroplaning in sliding is proportional to tire inflation pressure (Velocity = $10.35 \sqrt{\text{Pressure}}$). Tires operating at normal pressure of 24 psi require a minimum velocity of 51 mph. In other words, hydroplaning is not likely to take place on highways at moderate speeds unless the road does not drain

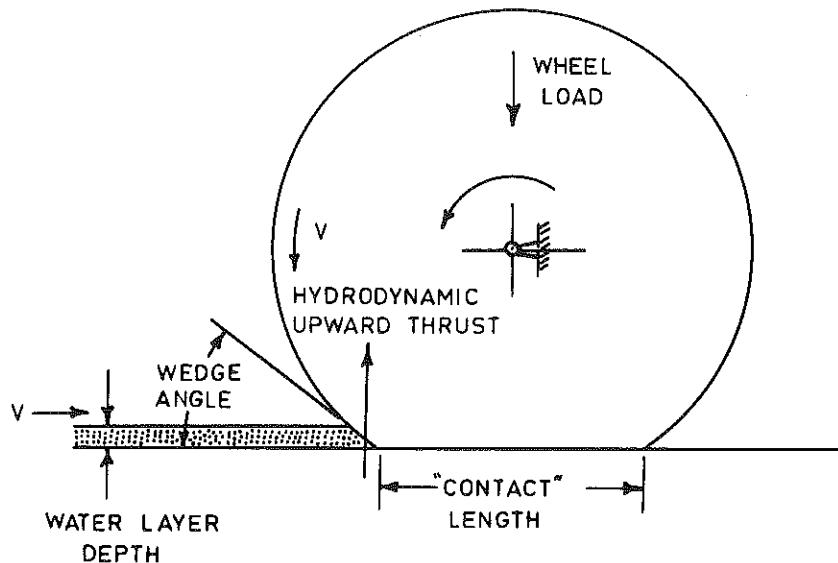

A - GENERAL

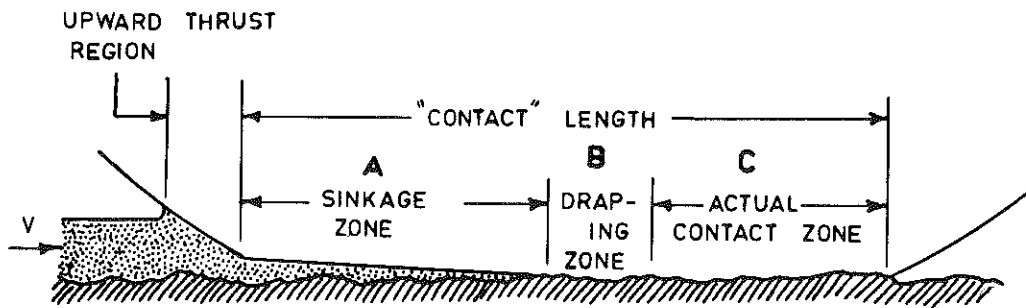

B - THREE ZONES IN THE CONTACT AREA (ROUGH SURFACE)

FIGURE 13

properly. The highway engineer should be concerned with severe rutting in the wheel tracks or other areas of the pavement where puddling may occur. Curves on four-lane roads, in particular, may be hazardous during periods of heavy rainfall because the cross drainage from the adjacent lane may result in an excessive depth of water. Vehicles traveling at speeds above the design velocity of the superelevation are likely to encounter slipping beyond the critical slip of the pavement, thus precipitating total hydroplaning. In any event, hydroplaning is not likely to take place unless the water depth exceeds the total depth of the tire tread and texture of the pavement.

Seasons - Surface characteristics of pavements are affected by weather. Consequently the skid resistance of pavements differ from one season of the year to another. Also the weather of each successive year is not likely to be an exact duplicate of the preceeding year. Some differences, therefore, may be expected in frictional levels of roads from one year to another after all other influences have been accounted for. The friction changes encountered on a given surface in Kentucky is illustrated in Figure 14.

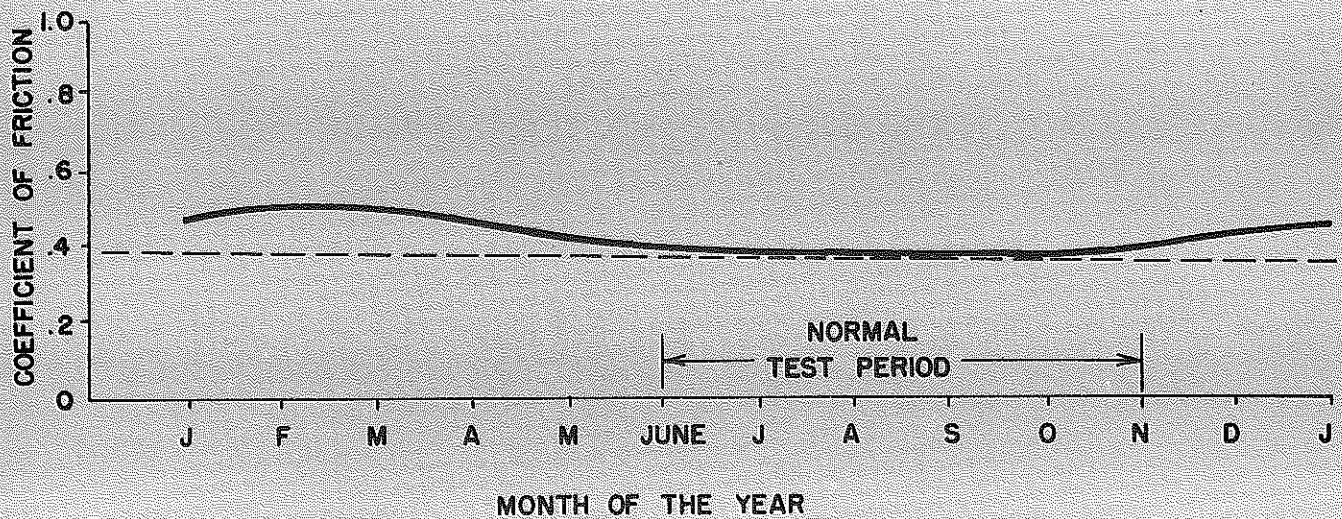

FIGURE 14

A pavement will exhibit the lowest friction during summer and fall and the highest during late winter and early spring. The degree of variability is influenced largely by the texture and material composition of the pavement. Aggregates that are most polished or abrasion sensitive are likely to experience the greatest changes. Limestones in particular are sensitive to environmental changes. Friction changes in the order 0.1 coefficient of friction are not uncommon.

The mechanisms responsible for the seasonal changes in friction are not well understood. Much research is needed to clarify the phenomena. It will suffice to say at this time that the changes in seasonal temperature, precipitation (both intensity and duration), and chemical and abrasive nature of road film deposits, coupled with changes in rubber dynamic properties with temperature, contribute to altering the microscopic texture of the pavement.

In the evaluation of surface skid resistance, we should be aware of the seasonal influence. Skid testing should be confined to the month during which we can expect friction to be the lowest. We are primarily concerned with the minimum friction of a pavement when exercising judgement as to its safety.

Drought - During period of little or no precipitation a road film composed of dust, oil, rubber and other foreign matter will accumulate on the pavement causing the surface to become more polished. The longer the period of drought, the more severe the polishing and the road film thickness increases. A pavement can become extremely slippery, particularly during the first few minutes of rainfall. With additional rainfall, the lubricating mixture will be diluted and eventually washed away leaving the surface clean, but more

slippery than at the beginning of the period of drought. Prolonged precipitation and abrasive action of traffic will roughen the polished aggregates and may restore the skid resistance of the surface to the pre-drought level. If the skid resistance of a given pavement was monitored during a 30-day drought, friction may decrease as illustrated in Figure 15. The skid resistance of pavements, therefore, is dependent upon the time lapse since the last rain.

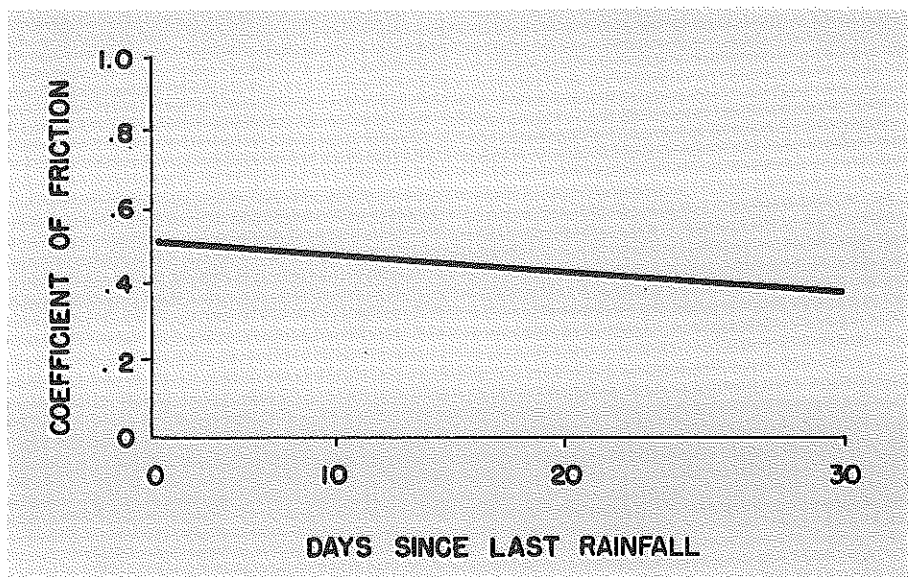

FIGURE 15

Traffic - Both accumulation of total vehicle passes and traffic volume profoundly affect skid resistance of pavements. Traffic polishes as well as wears pavements. The process of polishing can best be illustrated graphically. Figure 16 shows a reduction in friction on several surface types as the number of vehicles traversing the surfaces increases. Presently Kentucky Rock Asphalt pavements are the only surfaces in Kentucky that wear without an accompanying loss of friction. This is possible whenever a pavement is composed of polish-resistant aggregates and the attrition of the aggregate and binder occurs before the aggregate experiences significant polishing. Any surface containing limestone aggregates, in particular, either coarse or fine, will polish and in time may become slippery.

The performance of a particular surface from the standpoint of friction must be judged on the basis of in-service performance. As shown in Figure 16, the loss of friction is usually most severe during the first two years after construction. Thereafter the rate of polishing decreases and eventually experiences little additional polishing. It is at this time that we can make a final judgement as to the frictional characteristics of the surface. On bituminous pavements about 5-7 million vehicle passes (equivalent to five years with ADT of 5,000) may be required while concrete surfaces may require 15-20 million.

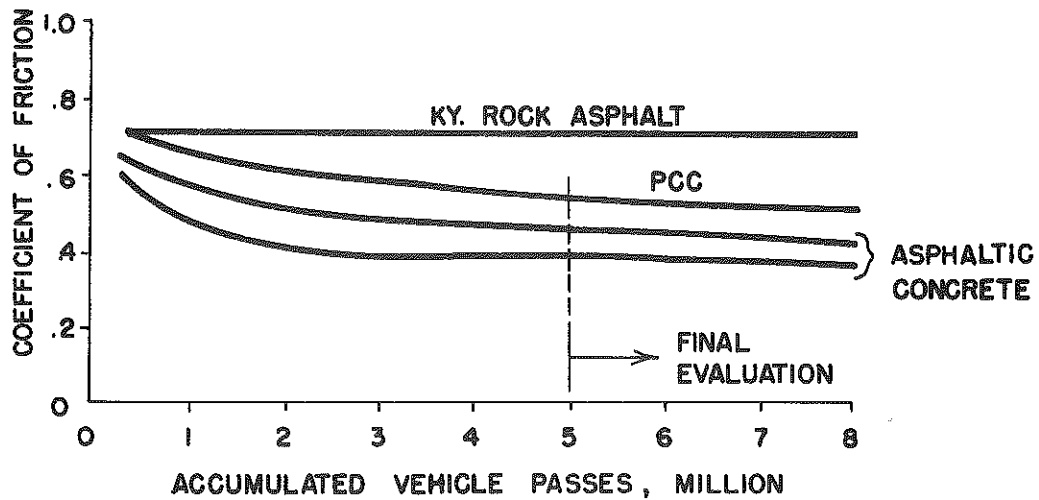

FIGURE 16

Longitudinal and Transverse Variation in Friction - On a given pavement the skid resistance in the wheel tracks will not differ greatly from one location to another. Most pavements are quite homogeneous and do not need to be skid tested throughout the entire project. Several test sections on representative sections, or sections selected at random or at equal intervals, will insure an accurate determination of skid resistance. Surface treatments will necessitate selection of a larger number of test areas since it is likely to be less homogeneous.

Special attention must be given to portions of roadways which possess steep curves or grades. These locations are likely to be less skid resistant than straight and flat sections. Curves on two-lane highways, in particular, are notoriously known for becoming slippery. Vehicles maneuvering curves in dry weather usually exceed the design velocity of the curve which will cause tires to slip. Sometimes the slippage is quite severe and an audible squeal may result. This slipping of tires induces undue polishing and wear of the pavement.

On steep grades vehicles are required to impart greater tractional force to the pavement in order to maintain constant speed. This will cause the tires to experience greater slipping than on a straightaway.

Skid resistance along the transverse profile of most pavements varies considerably, as shown in Figure 17. Areas of the surface traversed by the largest number of vehicle tires will exhibit the least friction. Usually the inside wheel track of a two-lane highway, and the inside wheel track of the outer lane of multilane highways, will be the most polished.

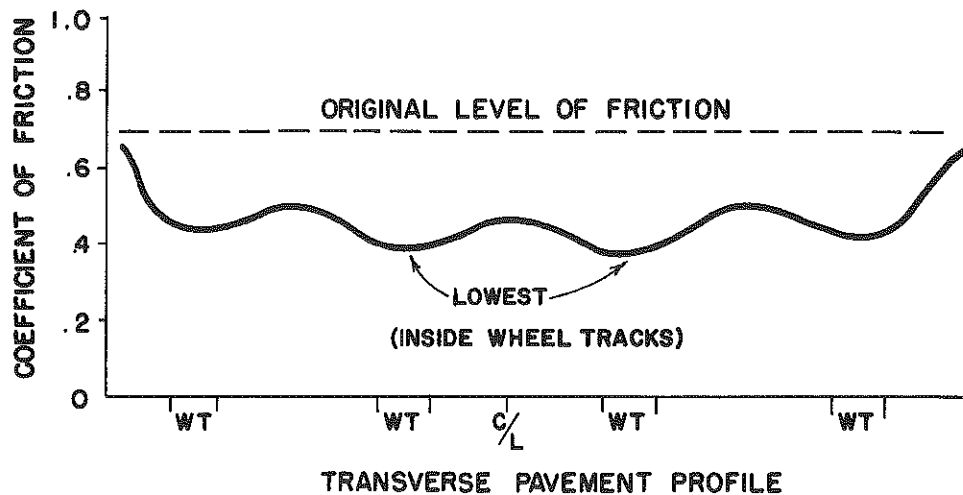

FIGURE 17

ROAD FRICTION MEASUREMENT

Many testers are used today to obtain a friction measurement between tire and pavement. The mode of operation of the testers varies, but the various modes can generally be divided into four groups: 1) steady-state sliding, 2) non-steady-state sliding, 3) steady-state slip, and 4) non-steady-state-slip. The steady-state sliding group includes all testers which measure the sliding coefficient at a constant velocity - such as the towed trailer tester and the Drag Tester. The non-steady-state sliding group, also referred to as energy devices, operate on the principle of converting

kinetic or potential energy into frictional energy during the test. These devices usually measure a mean coefficient over a velocity range. A skidding, decelerating automobile would be included in this category since it is converting the kinetic energy of the automobile into frictional energy. The British Portable Tester, another example of this group, converts potential energy into kinetic energy, then into frictional energy. The steady-state slip group includes testers which operate at a constant rate of slip with respect to the pavement surface - most of these testers are found in Europe. The non-steady-state slip testers are primarily designed for steady-state sliding except that they are equipped with brake systems which permit retardation of wheel lock-up to 10 seconds. The General Motors Proving Grounds trailer tester fits this latter category. The Division of Research is purchasing this tester and it should be available for field testing not later than December 1968.

The coefficients obtained by friction-testing devices are largely dependent on the mode of operation and are not directly comparable since rubber friction is dependent on speed and accompanying temperature changes. The coefficient of friction is therefore not an absolute number and may best be regarded as a performance value. This does not mean that a specific coefficient of friction does not exist between a given tire and pavement surface for specific test conditions. On a given pavement, under identical test conditions, the coefficient should be reproducible, either by the particular tester involved or by a similar tester.

Automobiles

Coefficients obtained by means of skidding automobile may be determined by using one of three combinations of measurements - velocity and distance, velocity and time, or deceleration. Using any one of these, several coefficients can be determined: mean f , f for a velocity increment, and f at a specific velocity in the case of deceleration measurement.

The Kentucky Department of Highways uses an automobile as an interim standard method of test. The test consists of skidding an automobile equipped with standard skid-test tires (with its wheels locked), on a wetted pavement from a velocity above 30 mph. From the resultant recording of velocity and distance, the coefficient of friction between 30 mph and 20 mph is calculated. The automobile will be replaced as a standard method of test once the GM trailer tester becomes available.

Automobiles or other skidding vehicles are usually used in measuring skid distances, and with the use of the equation $f = V^2/30s$, a coefficient of friction is calculated. The computed f , however, does not indicate friction at velocity V nor is it possible to determine at what particular speed f was in fact experienced by the tires. The problem arises from the fact that f vs speed forms a non-linear relationship, which is to say, the above equation is inappropriate.

The principal advantages of using an automobile as a skid testing device are:

1. Measured coefficient (velocity increment) reflects realistic conditions in a panic-stop situation.

2. Capital investment in equipment is low when compared to trailer tester.

The principal disadvantages are:

1. Test speed confined to low velocities (below normal driving speeds).
2. Limited test volume (about 5 to 6 sites a day).
3. Hazardous to test personnel and highway users.
4. High operating cost (about \$5.00 per test or \$25.00 per lane per site).
5. Requires a crew of four and a water truck for wetting the pavement.

Trailers

The most common device for measuring friction today is the trailer tester operating in the steady-state sliding mode. The testing unit consists of a truck equipped with water supply and instrumentation associated with friction monitoring and a one- or two-wheel trailer pulled behind it. The trailers are basically equipped with standard test tires, brake system, nozzles for spraying water under the tires, and tire friction sensing devices. A good example of such a device is the GM trailer shown in Figure 18. These devices are being constructed according to standardized specifications as outlined in ASTM E 274-65T, Tentative Standard Specifications for a Method of Testing for Skid Resistance of Pavements Using a Trailer.

The undesirable aspect of the trailer devices are that they measure sliding friction at a specific velocity. Such a condition rarely, if every, is experienced with an automobile and, therefore, the indicated friction can be used only for determining relative friction between pavements. Also, the testers are very expensive (\$25,000 to \$90,000). Their principal advantages are:

1. Standardized method of test.
2. High velocity test capability (up to 90 mph).
3. Safe usage on the road.
4. Does not interfere with normal flow of traffic.
5. High volume test capability (up to 200 tests a day).
6. One to two test operators.
7. Low test costs (about 50¢ per test).

Portable Testers

Several portable skid testing devices are in usage today. Among these the Drag Tester and the British Pendulum Tester are most prevalent. The mode

FIGURE 18

MODEL 965 PAVEMENT FRICTION TESTER

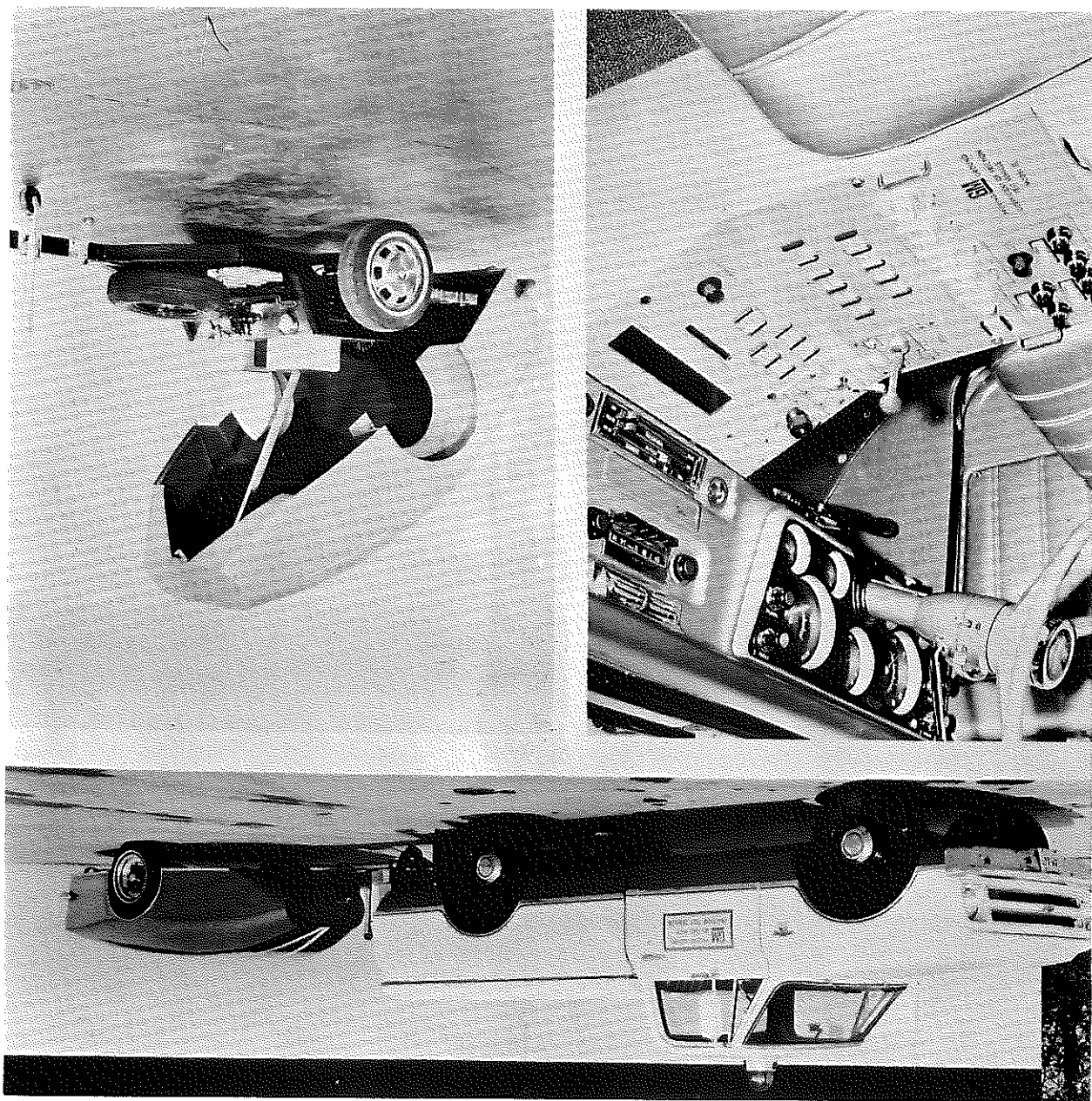

of operation of the testers varies as mentioned before. These devices were developed in an attempt to provide inexpensive and simple method of friction measurement. However, principally due to their low velocity of test, these devices have limited applications and it is doubtful that any portable tester can ever be relied upon for accurate assessment of pavement friction. Their main advantages are:

1. Low purchase price (\$550 to \$1200).
2. Low maintenance costs.
3. Can be operated by one technician on a limited scale.
4. Test capability of small or otherwise inaccessible areas (such as highway curves).
5. Easy familiarization and simple test procedure.

The disadvantages in using a portable tester are:

1. Low test velocity (1 to 7 mph).
2. Limited application.
3. Hazardous to test personnel.
4. Time consuming (British Portable Tester).
5. Limited volume of test capability.
6. Can have high operating costs compared to trailer testers.

Tester Comparison

The skid resistance numbers, or coefficients of friction, obtained on a given surface will differ depending on the device used in making the measurement. This difference is primarily caused by the operating speed of the device at the rubber-pavement contact area and by the operating mode of the tester. Figure 19 was designed to illustrate the differing skid resistances that may be obtained on a given pavement with several testing devices.

The Drag Tester yields one test value only because its best test speed is fixed. The trailer will provide test values depending on the test velocity selected and whether the trailer was operated in the sliding or the slip mode. The incipient friction, however, will always be greater than skid resistance in sliding. Similarly, the automobile, when used to measure friction at small velocity increments, will encounter a friction decrease with increase in velocity. For a given velocity, the value will always be less than measured with a trailer in either mode of operation.

The slopes of the friction-velocity curves, as shown in Figure 19, for a given method of test is governed by the type of pavement involved and by its composition and texture. Even for the same pavement type, such as Class I

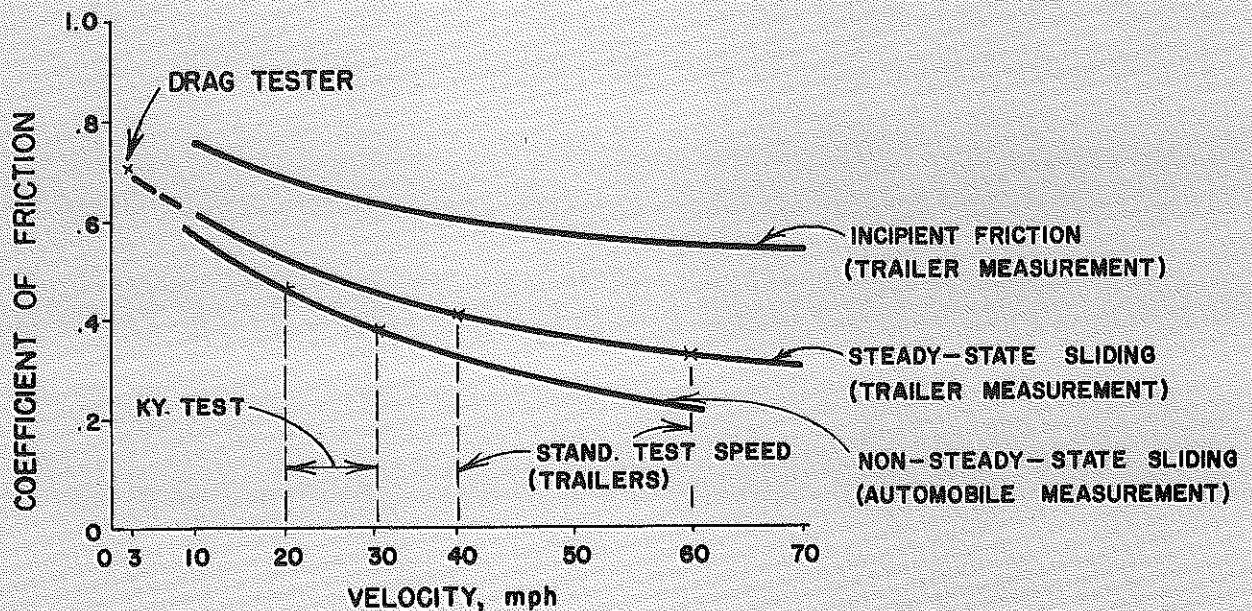

FIGURE 19

bituminous pavements, the curves for several surfaces with differing skid resistances may not be parallel and, in some cases, may intersect at some velocity. This is especially true when test results of different pavement types are compared and judgement of friction characteristics are arrived at on the basis of low-velocity tests. Figure 20 demonstrates how an erroneous assessment of skid resistance at normal driving speeds (40 to 70 mph) can result when the Drag Tester is used. At the test speed of 60 mph, the trailer rates the surfaces in the following order: 1, 2, 3 and 4. The Drag Tester, operating at a sliding velocity of about 3 mph, however, would rate the friction level of the surfaces as follows: 1, 4, 2 and 3.

On the highways, the primary concern is with skid resistance of pavements at normal driving speeds, usually between 40 mph and 70 mph. There is a need to provide adequate friction between the pavement and tire that would permit the driver to exercise normal driving maneuvers (braking, cornering, passing and accelerating) without losing control of the vehicle. Of secondary concern is the ability of the pavement to stop the vehicle in the shortest possible distance once a panic-stop situation arises and the driver locks the wheels of the vehicle and skids.

SKID TESTER CORRELATION

Each method of test, mode of tester operation, and velocity of test yields unlike numbers as an expression of skid resistance. To relate one method of test with another, the testers must be utilized according to standardized procedures of test on a number of selected surfaces. The tests should be conducted at about the same time in order to minimize extraneous influences (such as temperature). Devices capable of operating at test speeds

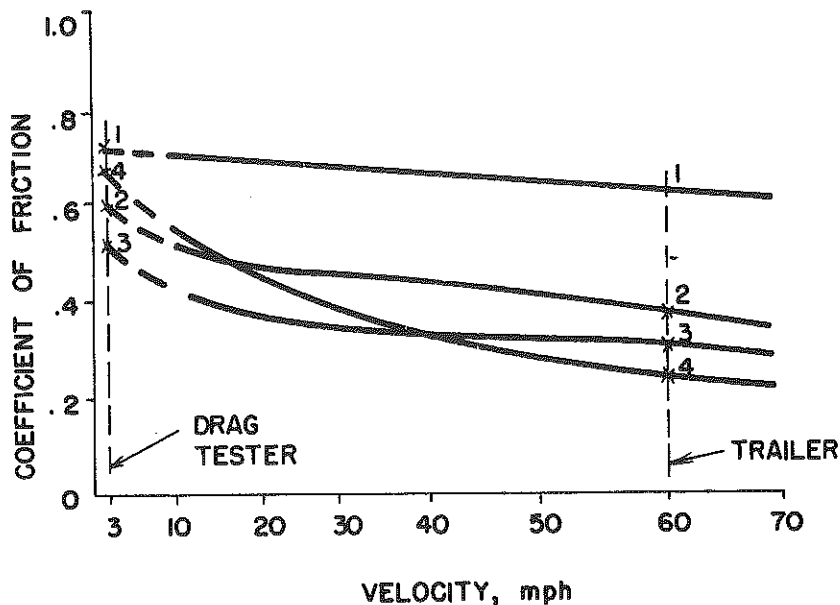

FIGURE 20

of 20 mph or higher may be compared on surfaces of unlike compositions and textures. Portable testers, such as the Drag Tester, on the other hand, are highly sensitive to texture differences among pavements because of their low operating velocity and, therefore, selection of test surfaces must be confined to those possessing similar textures.

Trailers vs Automobile

The Division of Research participated in a skid-correlation study at Ocala, Florida, with its skid-test automobile during November 1967. The study was sponsored by the Florida State Road Department, the Bureau of Public Roads, and the ASTM Committee E-17 on Skid Resistance. The primary objectives of the study were to compare the performance of skid-test trailers on various textured surfaces with different coefficients of friction and to correlate with stopping distances of automobiles. The Division of Research vehicle was instrumented to record on a strip-chart recorder the distance and velocity during a skidding excursion. From the resultant recordings, the coefficient of friction $f_M(30-20)$, which is referred to here as the Kentucky interim standard measurement, was determined also. The relationship between this coefficient and the trailer test measurements at 40 mph (principal test velocity as recommended by ASTM) is shown in Figure 21. This graph may be used for extrapolation of trailer-measured skid resistance for a known value of $f_M(30-20)$ on any pavement surface. The two measurements have a high degree of correlation. Similar graphs for trailer tests at 20 mph and 60 mph are also available, but are not presented in this discussion.

Automobile vs Drag Tester

A Drag Tester was used in conjunction with the interim standard method of test using an automobile on various surfaces in Kentucky throughout the

summer skid-test period in 1967. A good correlation was found between the two measurements on Class I bituminous pavements resulting in a recommendation to place these testers in each highway district. Further effort will be required to determine whether the Drag Tester is suitable for use on other pavements as well. If a correlation is found on other surface types, the relationship between the two test values are not expected to be the same as for the Class I bituminous pavements. Figure 22 may be used to convert the Drag Tester Number to $f_M(30-20)$ or vice versa. The regression curve is identical to the one exhibited in the instruction manual on Drag Testers distributed earlier.

Drag Tester vs Trailer

A direct comparison of the Drag Tester and trailers is not available at this time. However, an indirect relationship was established (for Class I bituminous pavements) by using Figures 21 and 22 where their correlation with $f_M(30-20)$ was established. The resultant curve in Figure 23 may be a reasonably good approximation, but the correlation can be expected to be less reliable.

SKID-RESISTANCE REQUIREMENTS

Skid-resistance requirements for maintenance and surface-mix design purposes must be established if meaningful improvements in highway safety is to be realized. Arbitrary judgements as to minimum requirements will not suffice because the issue is much too important economically and safety wise to every highway user. Economic impact, in particular, will have to be carefully ascertained.

The Division of Research has initiated a three year study of pavement slipperiness. One of the objectives in the study will be to establish minimum requirements for skid resistance based on available wet-pavement accident statistics. In the interim a coefficient of friction [$f_M(30-20)$] of 0.40 will be recommended as a guideline for defining a minimum desirable friction level. This value is not to be assumed as the minimum permissible friction for all pavement surfaces irrespective of class of highway, traffic volume, speed limit, roadway geometry, etc. The final judgement as to adequacy of friction on any given surface should be coupled with the considerations discussed above.

CORRELATION BETWEEN SKID TRAILERS (40 M.P.H. TESTS)
 AND AUTOMOBILE $[f_M (30-20)]$
 (FLORIDA SKID CORRELATION STUDY - SITE I, NOV. 1967)

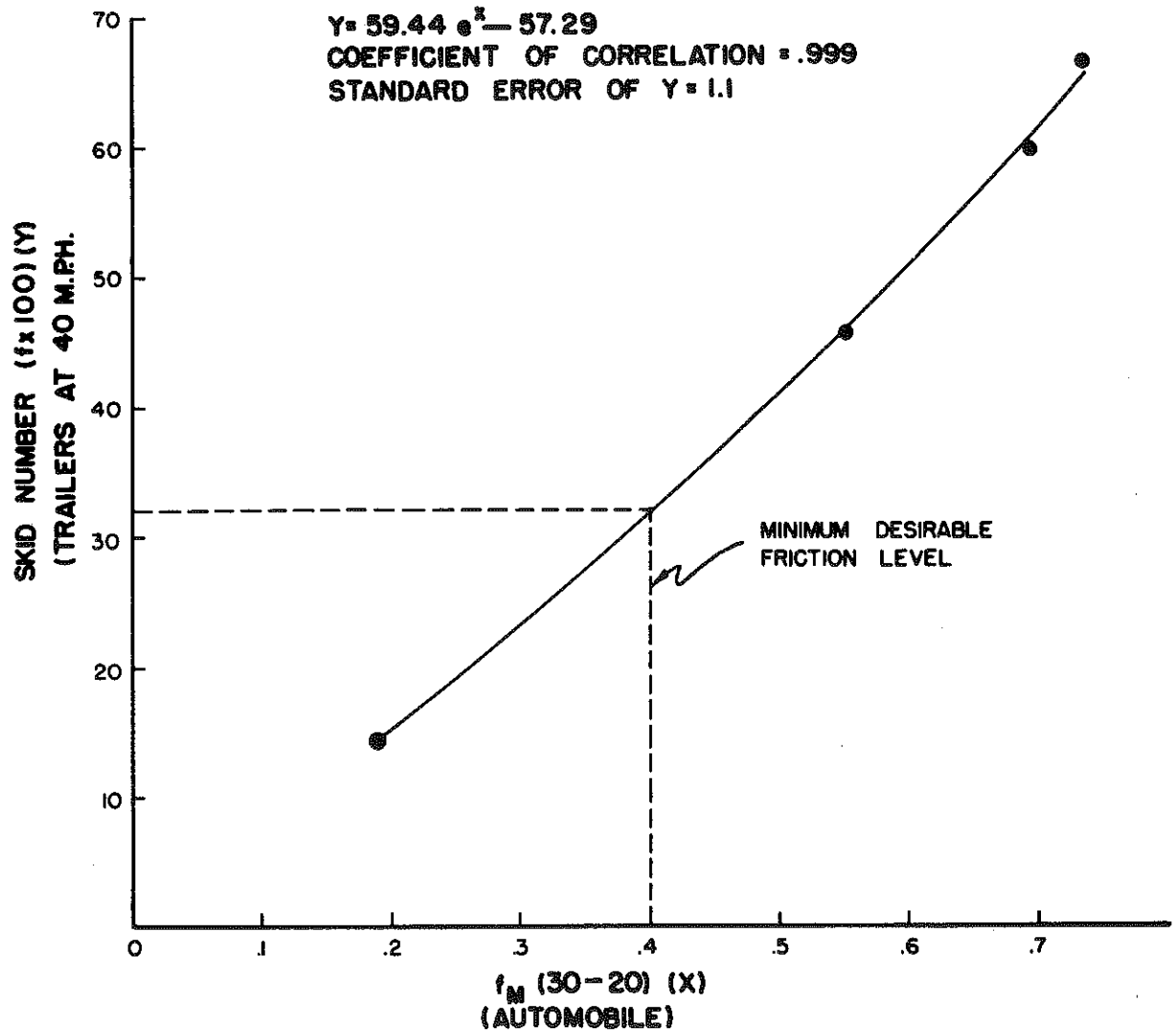

FIGURE 21

CORRELATION BETWEEN DRAG TESTER
AND AUTOMOBILE TEST f_M (30-20)
ON CLASS I BITUMINOUS PAVEMENTS
(SUMMER OF 1967)

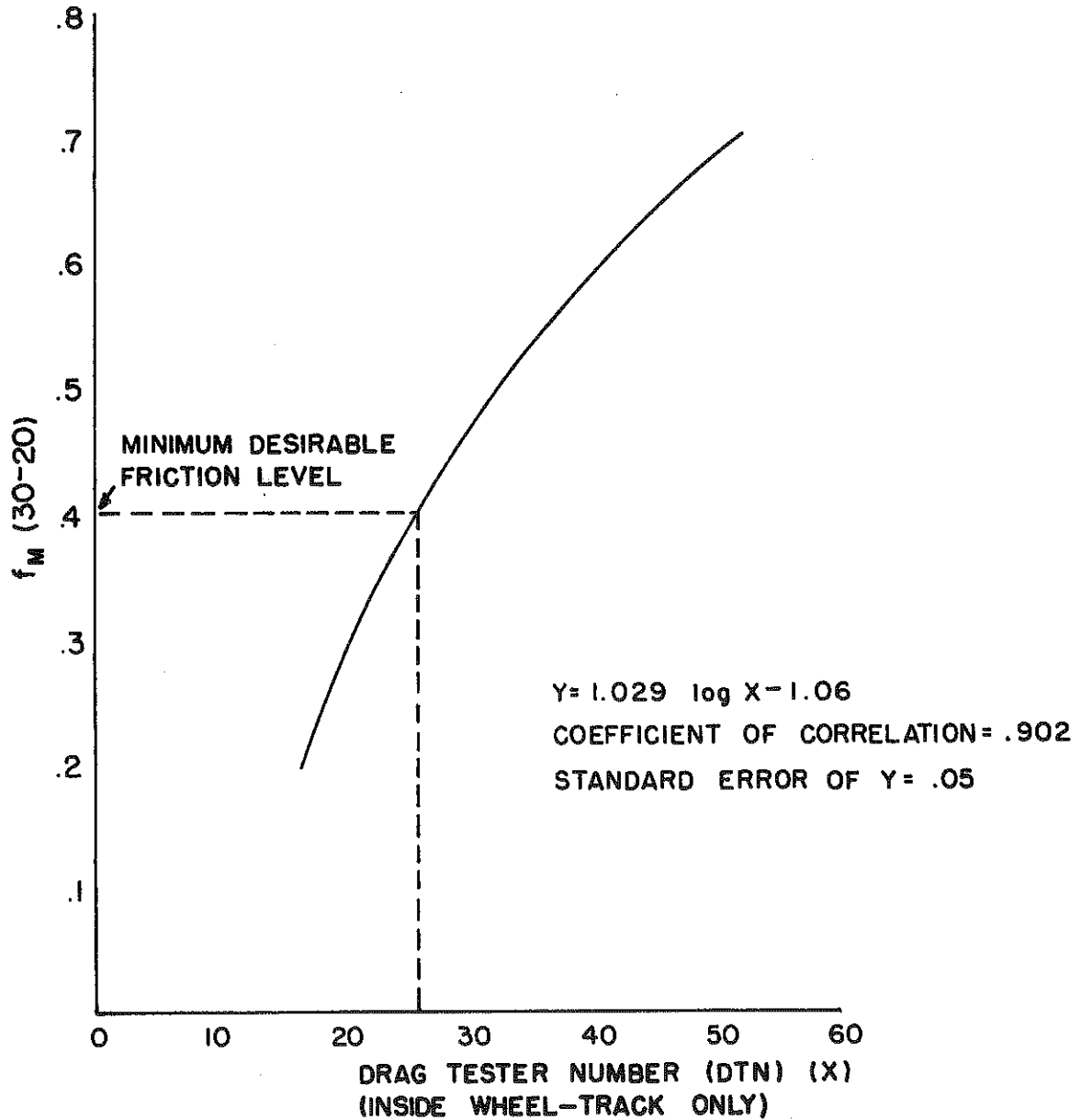

FIGURE 22

RELATIONSHIP BETWEEN DRAG TESTER
AND SKID TRAILERS
(CLASS I BITUMINOUS PAVEMENTS)

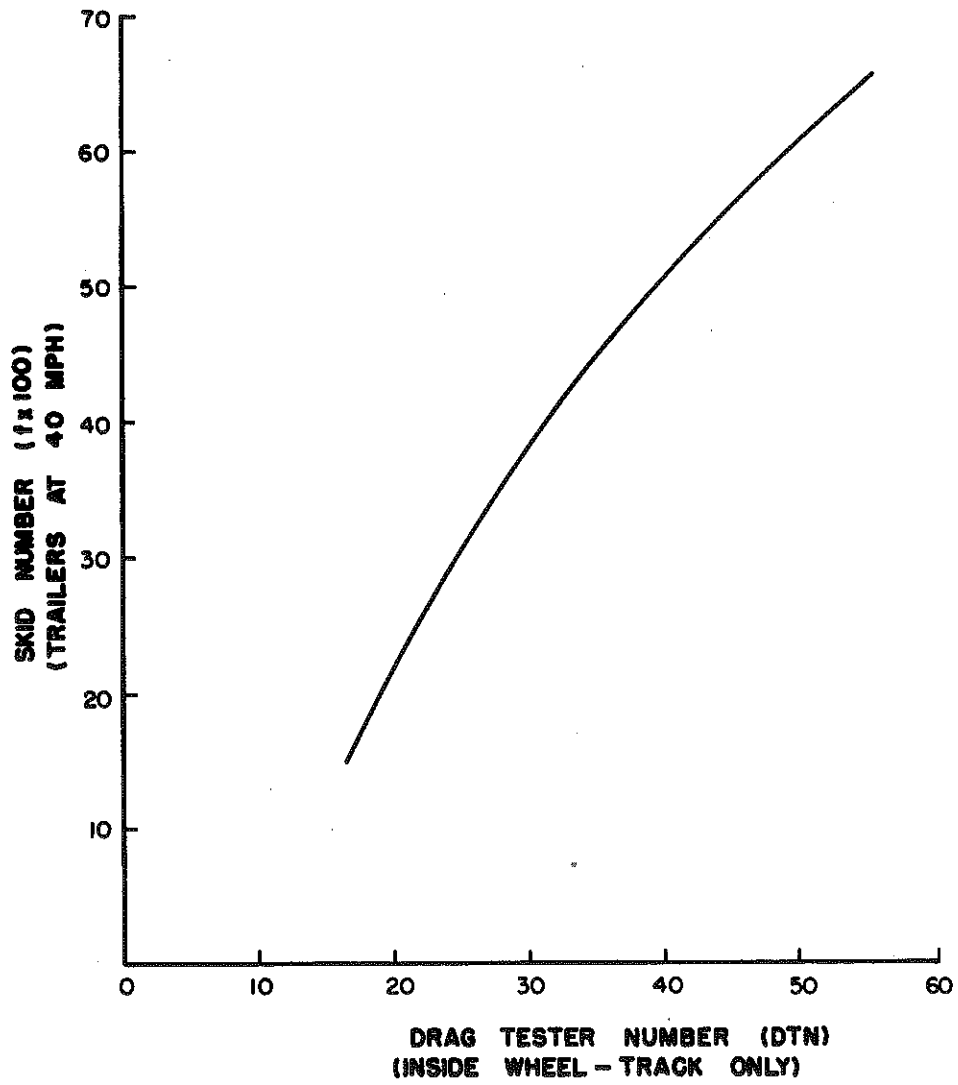

FIGURE 23

REFERENCES

1. Rizenbergs, R. L. and Ward, H. A., "Skid Testing With An Automobile", Highway Research Board, Record No. 187, pp 115-136, 1967.
2. Kummer, H. W. and Meyer, W. E., "Measurement of Skid Resistance", ASTM STP 326, 1962.
3. Moore, D. F., "Prediction of Skid-Resistance Gradient and Drainage Characteristics for Pavements", Highway Research Board, Record No. 131, pp 181-203, 1966.
4. "Instruction Manual for Drag Testers", Kentucky Department of Highways, Division of Research, 1968.

