

COMMONWEALTH OF KENTUCKY
DEPARTMENT OF TRANSPORTATION
FRANKFORT, KENTUCKY 40601
BUREAU OF HIGHWAYS
BILLY PAXTON
COMMISSIONER

BILLY PAXTON
SECRETARY

WENDELL H. FORD
GOVERNOR
H.3.25

October 25, 1974

MEMO TO: J. R. Harbison
State Highway Engineer
Chairman, Research Committee

SUBJECT: Research Report No. 402; "Bridge Decks Constructed for Increased Durability;"
KYP-71-25; HPR-PL-1(10), Part III

If one accepts the hypothesis or premise that the quality of portland cement concrete may yet be improved to provide adequate durability and resistance and to, thereby, assure long-time, maintenance-free service in bridge decks, five general areas of needed improvements may be defined, as follows:

1. Quality of Materials (Aggregates)
 - a. Additional control of proportions of unsound, absorptive particles in composite aggregates.
 - b. Additional control of proportions of expansive and reactive particles in composite aggregates.
2. Design and Control of Concrete Mixture
 - a. Minimize mixing water demands by improving concrete-making properties of aggregates and using water-reducing admixtures. A goal might be 30 gallons of water per cubic yard, maximum.
 - b. Minimize bleeding.
 - c. Optimize air content and loss of strength; water reduction must accompany increasing air content in normal range or loss of strength results.
3. Construction Methods
 - a. Employ production and paving-train practices which assure regulated uniformity and expeditious progress.
 - b. Provide additional assurances of adequate consolidation of concrete in place.
 - c. Provide surface consolidation in paving train; prevent "bird baths."
 - d. Provide texturing, if required, and application of curing covers in paving train.
 - e. Employ simultaneous, counter-balancing pouring patterns, counter weights, or tie-downs.
4. Design of Deck Systems
 - a. Minimize contraflexures and oscillations.
 - b. Minimize tensile stresses in concrete; these stresses arise principally from temperature elongation of steel.
 - c. Develop paneled deck system.
5. Maintenance
 - a. Minimize use of de-icing salts.
 - b. Remove snow and ice to avoid damage from successive melting (saturation) and freezing cycles.
 - c. Provide flushing with water to remove corrosive de-icing chemicals.

A brief chronology of Kentucky's adaptive design and specification changes intended to improve concrete bridge deck durability follows. This listing was abstracted from Mr. Vansant's compilation ("Bridge Decks: Precepts to Concepts," presented before Highway Research Board; August 1970; Sacramento, California):

- 1956 - Specified air entrainment for deck concrete,
- 1962 - Specified full-width finishing machines,
- 1962 - Specified linseed oil protective coating,
- 1964 - Specified membrane curing,
- 1964 - Increased concrete cover over reinforcement to 2 in.,
- 1965 - Specified template clearance check for finishing machines,
- 1966 - Specified Class AA concrete (6.6 sacks of cement, maximum of 33 gal water per cu yd),
- 1967 - Specified tie-down of reinforcing steel -- 8-ft centers, each direction,
- 1969 - Specified temperature limitations for hot-weather concreting; nighttime concreting permitted, and
- 1970 - Specified rotary, compacting, finishing machine.

Although broomed-finishing and limitations on hot-weather concreting were specified for the I-24 Ohio River Bridge, the I-24 Tennessee River Bridge, the US 25 Ohio River Bridge at Covington, and the I-275 and I-471 bridges, those bridges have or will receive membrane-type or latex concrete overlays prior to opening them to traffic; and those original features will, thereby, be hidden. Any benefits to the durability of the concrete arising from recent improvements will likely be credited, some years hence, to the protective overlays. About this same time, a series of bridges on I 64, between Lexington and Frankfort were chosen for evaluation of the two features mentioned above -- plus two additional features. The broomed texture, of course, was intended to improve skid resistance; wear or attrition under traffic was expected and, from the skid-resistance standpoint, would comprise an independent evaluation; however, the effect of relatively deep texturing on the durability at the surface also required evaluation. The two additional features on I 64 issued from an intuitive need for a consolidating action on the fresh concrete after bleeding ceased but before a firm set occurred. Rotary plate finishing machines originated perhaps 40 years ago; the impacting action and vibrations provide a type of re-vibration which is believed to be beneficial. This type of machine was used on the concrete overlay on the truss spans of the Clark Memorial Bridge in 1968. This special feature was provided on the twin bridges over Elkhorn Creek, the southbound side of the four-lane bridge carrying KY 341 over I 64 at Midway, and on the eastbound, I-64 bridge over US 60 near Jett. The deck of the bridge at Jett was constructed in two layers. One purpose of the layered construction was to provide a firm foundation and reactance for the rotary, impacting finisher; it was also desired to test the feasibility and performance of layered construction -- and of making future repairs, if needed.

Various construction details, tests on cores, electrical potentials (corrosion detection tests), and electrical resistivity tests are included in the report. The latter tests will be repeated at intervals of a few years in an attempt to determine the time to the beginning of deterioration. The histories of these bridges may be compared, some time in the future, to those receiving protective overlays.

Respectfully submitted,

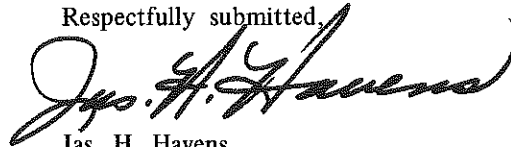

Jas. H. Havens
Director of Research

JHH:gd
Attachment
cc's: Research Committee

TECHNICAL REPORT STANDARD TITLE PAGE

1. Report No.		2. Government Accession No.		3. Recipient's Catalog No.	
4. Title and Subtitle Bridge Decks Constructed for Increased Durability				5. Report Date October 1974	
				6. Performing Organization Code	
7. Author(s) A. S. Rahal				8. Performing Organization Report No. 402	
9. Performing Organization Name and Address Division of Research Kentucky Bureau of Highways 533 South Limestone Lexington, Kentucky 40508				10. Work Unit No.	
				11. Contract or Grant No. KYP-71-25	
12. Sponsoring Agency Name and Address				13. Type of Report and Period Covered Interim	
				14. Sponsoring Agency Code	
15. Supplementary Notes Study Title: Specially Constructed Bridges					
16. Abstract The experimental features incorporated in this study were compaction, brooming, and bi-layered construction. Broomed surfaces initially exhibited a higher skidding resistance than non-broomed surfaces: broomed surfaces, however, wear more rapidly. No conclusive evaluation could be made at this time of the bilayered system and of tests made on the concrete cores. Electrical measurements made on the decks indicated there was no active corrosion of the steel.					
17. Key Words Bridge Decks Compaction Brooming Bi-layered Construction			18. Distribution Statement Skid Resistance Corrosion Resistance		
19. Security Classif. (of this report)		20. Security Classif. (of this page)		21. No. of Pages	22. Price

Research Report
402

**BRIDGE DECKS CONSTRUCTED
FOR INCREASED DURABILITY**

KYP-71-25, HPR-PL-1(10)

by

Assaf S. Rahal
Research Engineer Senior

Division of Research
Bureau of Highways
DEPARTMENT OF TRANSPORTATION
Commonwealth of Kentucky

The contents of this report reflect the views of the author who is responsible for the facts and the accuracy of the data presented herein. The contents do not necessarily reflect the official views or policies of the Bureau of Highways. This report does not constitute a standard, specification, or regulation.

October 1974

INTRODUCTION

Thirteen bridges on the section of I 64 between Frankfort and Lexington, shown in Figure 1, built in 1973 and 1974, became subject to research surveillance by prior decisions to incorporate experimental features into the construction of several decks. The most prominent feature was the construction of the deck of the eastbound bridge over US 60 in two layers and the use of an impacting, rotary disk, finishing machine on the top layer. The same type of finishing machine was specified on the southbound side of the KY 341 bridge over I 64 at Midway and on the twin bridges carrying I 64 over Elkhorn Creek.

Broomed finishes were specified on the following bridges:

- Ducker's Road over I 64,
- Twin bridges over Woodlake Road,
- Westbound I-64 bridge over US 421,
- Southbound side of KY 341 bridge over I 64, and
- Twin bridges over Elkhorn Creek,

The remaining bridges, or decks, identified here as "conventional," were those which are finished with a burlap drag and were not compacted. They are:

- Westbound I 64 over US 60 at Jett,
- Eastbound I 64 over US 421,
- Northbound KY 341 over I 64 at Midway,
- Cane Run Road over I 64,
- US 62 over I 64, and
- Yarnallton Road over I 64.

Temperature limits were specified on all bridges; nighttime concreting was permitted. All concrete was Class AA, conforming to Special Provision No. 35-B, containing a 6.6 sacks of Type I cement per cubic yard (0.76 m^3), 6 ± 2 percent air, and a maximum of 33 gallons (0.163 m^3) of water per cubic yard (m^3). The slump requirement was $2 \pm 1/2$ inches ($5.08 \pm 1.27 \text{ cm}$), and the minimum 28-day compressive strength was 4,500 psi (31 MPa). Two inches (5 cm) of concrete cover above the top of the reinforcing steel and full-width, mechanical screeding was required. Limestone coarse aggregate for the twin, I-64 bridges over US 60 at Jett was supplied by Capital Stone Company at Frankfort. Limestone for all of the remaining bridges was supplied from Vulcan Materials' quarry at Clays Ferry. All concrete was ready-mixed.

Construction procedures were observed; data from field control tests were logged and summarized; cores were taken and analyzed; electrical potential measurements (corrosion potential tests) were made; electrical resistance measurements (as required for membrane overlays) were made at selected sites; and skid-resistance measurements were made periodically.

Although observations of performance and tests will be made at intervals during the next several years, reporting of construction details and beginning conditions is intended to provide a basis for future evaluations of performance and of benefits derived from experimental features. Current trends toward the use of protective overlays in the original construction of decks (Elizabethtown Bypass, I-24 over Ohio River, US 25 bridge over Ohio River at Covington, and others planned) add to the significance of this group of I-64 bridges from the standpoint of comparative performance, maintenance-free life, and repair costs.

CONSTRUCTION DETAILS

Broomed Finish

Inasmuch as broomed finishes had not been specified for pavements or bridge decks in Kentucky for many years prior to the I-24 bridge, which was then awaiting deck construction, various trial brooms and patterns were demonstrated on concrete panels formed on the construction site (at Jett) and wasted. Striations of 1/16 to 1/4 inch (1.59 to 6.35 mm) in depth and spacing appeared feasible; the 1/16- to 1/8-inch (1.59- to 3.18- mm) pattern was chosen.

Differences in opinions and methods, together with peculiarities associated with each bridge deck, resulted in differences in textures and patterns achieved. Ridges were at right angles to the centerline. Figures 2 and 3 show the brooming operation on the eastbound, I-64 bridge over US 60. This was the second bridge broomed; the first one was the Duckers Road bridge. Concreting on the Ducker's Road bridge began at the north end, and the concrete set somewhat before brooming was started. Texturing improved as concreting progressed southward. The Ducker's Road bridge deck was the only one placed in the evening and night.

Impacting, Rotary Disk, Flat Finisher

The compacting finisher is shown in operation on the eastbound I-64 bridge over US 60 in Figure 4. This operation followed at a time after spreading and screeding when the concrete would support the power float and the operator. All other workmen were prohibited from walking in or on the concrete after screeding. All of the decks where this machine was specified were finally broom finished.

Bi-Layered Construction (Eastbound I 64 over US 60, at Jett)

Additional efforts were made to securely affix the top mat of reinforcement to the forms to minimize vibration and displacement during placement and finishing of the concrete. Conventional, Class AA concrete was placed in the lower half of the deck which was rough-finished with wooden floats (Figure 5). Immediately after placement of the first lift and before the concrete set, all concrete was brushed from the top mat of reinforcement. The lower lift was cured for a minimum of seven days by placement of a double layer of wetted burlap over the top reinforcing mat. The burlap was maintained in a moist state continuously for the curing period. Upon completion of curing, the upper steel and surface of the lower lift were sandblasted to remove rust and laitance and provide a rough texture for bonding the upper lift thereto. All sand and(or) debris were removed from the surface prior to placement of the upper lift.

Concrete placed in the upper lift was Class AA modified as follows: (1) the maximum size of coarse aggregate did not exceed 3/6 inch (95 mm), (2) the slump was 1 to 2 inches (2.54 to 5.08 cm), and (3) the air content was 4 to 6 percent. The lower lift was thoroughly wetted for a minimum of 24 hours, and all excess water was removed prior to placing the upper lift. A portland cement grout bond-coat was spread prior to placement of the final lift (Figure 6). The placement of the upper lift is shown in Figure 7.

The upper lift was mechanically screeded and then compacted with a circular impacting power float. The surface was then broomed.

Curing

Final curing was consistent throughout. Resin-base curing compound was applied after the final finishing. Wetted-burlap or plastic covers followed.

Linseed Oil Treatments

Double applications of linseed oil were required on each deck prior to final acceptance. Cores were taken and electrical test on the decks were made before linseed oil was applied.

Construction Control Test Data

Air contents, slumps, and 28-day compressive strengths were compiled and are given in Table 1. Bridge-by-bridge, supplementary information is given in APPENDIX A.

POST-CONSTRUCTION TESTS

Electrical Resistances

Although measurements of electrical resistance between imbedded reinforcing steel and the top surface are being used primarily to test the impermeability of protective membrane-type overlays, trial measurements were made on a few selected, I-64 bridges. Tests on older bridges overlaid with latex-modified concrete were rather variable from time to time, and the test values seemed to be dependent on antecedent weather or lapse of time following rains. This type of variability was also found on the new bridge decks. Nevertheless, some measurements are included in this report in the form of contour maps (see APPENDIX B).

Corrosion Potentials

Salt-induced corrosion of reinforcing steel is believed to be a major cause of bridge deck delamination. To monitor the development and progress of corrosion, electrical potential measurements were made prior to opening decks to traffic and prior to application of linseed oil or de-icing salts. Measurements were obtained by making an electrical connection to the reinforcing steel and another to a copper-copper sulfate half-cell and the deck surface (Figure 8). The latter connection was made using a saturated sponge attached to the bottom of the half-cell. The electrical potentials were measured using a high-impedance voltmeter. Results of electrical surveys for the four bridges finished with the impacting, rotary disk float are shown in APPENDIX C. Potentials greater than 0.35 volts (350 millivolts) with respect to the copper-copper sulfate half-cell indicate corrosion of reinforcing steel (cf. Stratfull, R. F; *Half-Cell Potentials and the Corrosion of Steel in Concrete*; Record 433, Highway Research Board, 1973; pp 12-21).

Evaluation of Cores

All bridges were cored soon after construction. Three cores were taken from each deck (see APPENDIX D for core locations) and tested for properties such as air void content (by linear traverse), water absorption, specific gravity, unit weight, and permeability. Results are listed in Table 2. Data there represents the average from three cores taken from each bridge.

Skid Resistance

Skid resistance measurements were made on all surfaces soon after construction and periodically thereafter. Results are listed in Table 3.

DISCUSSION

There is no apparent significance in the electrical resistivity test results at this time. Electrical potential measurements (APPENDIX C) show there is not active corrosion of the steel.

No conclusions are drawn at this time from the various tests on the cores. Only cores from the bi-layered deck and the US 62 bridge over I 64 showed distinctively different (lower) air-void contents. The power float was used on one but not the other. No specific quality was found which could be attributed

directly and solely to the power float. All of the concretes appear to be at least equal if not superior to pavement concrete. If deterioration occurs prematurely, it should not casually be attributed to poor quality concrete or to poor construction practices.

Initial skid resistance tests show that broomed surfaces have significantly higher skid numbers than conventionally finished surfaces. The skid resistance and texture depths varied from site to site. Recent skid-resistance measurements made on the I-64, mainline bridges show there is a more rapid decrease of skid resistance on the broomed surfaces than on the companion, non-broomed surfaces. This indicates broomed surfaces wear more rapidly.

Evaluation of the bi-layered system of deck construction must await a due lapse of time. A high density was achieved at the expense of and loss of entrained air.

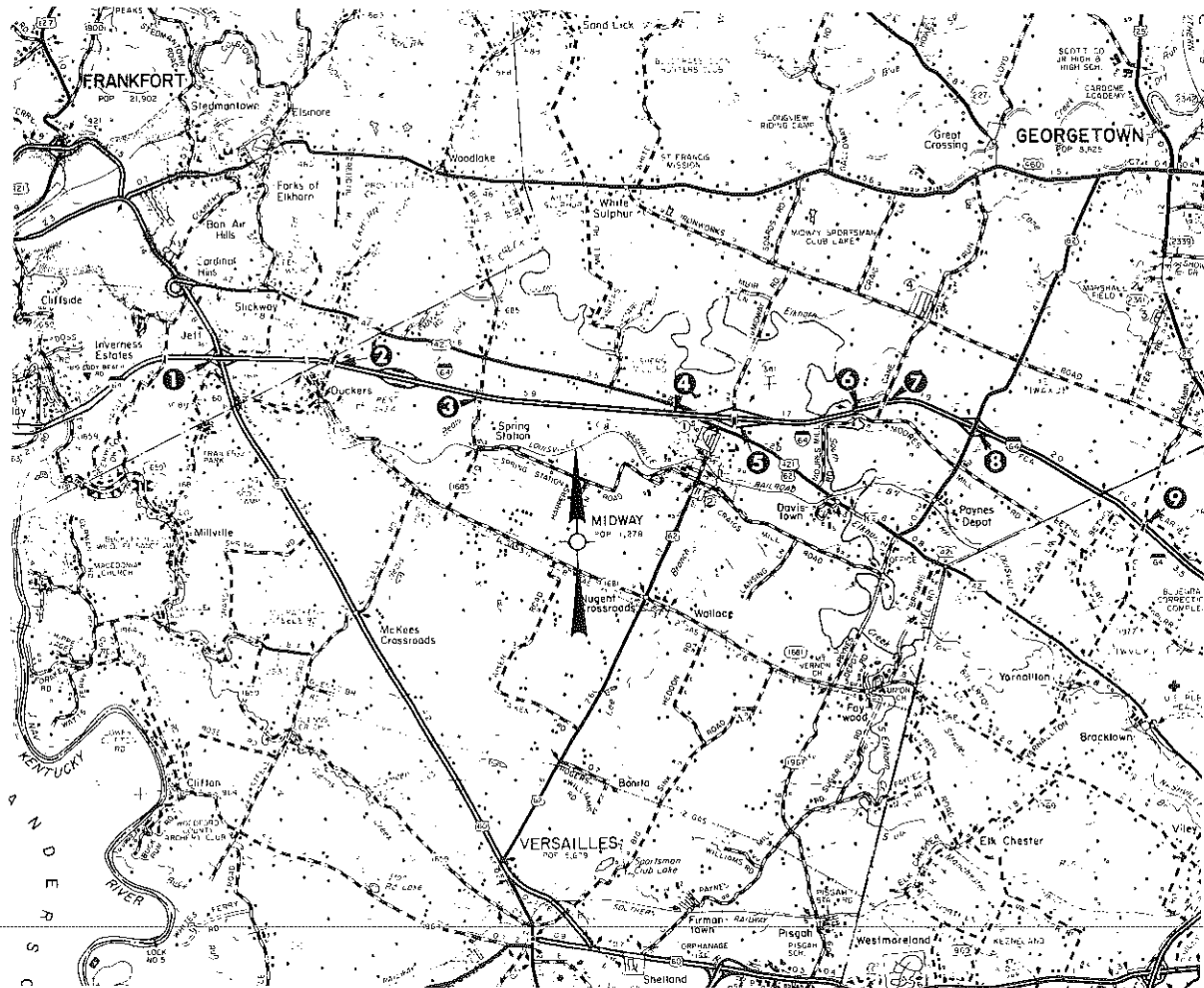

Figure 1. Location of Experimental and Control Bridges on I 64 between Lexington and Frankfort.

Figure 2. Transverse Brooming on the Eastbound, I-64 Bridge over US 60, Bi-Layered Deck.



Figure 3. Brooming from Work Bridge; Eastbound, I-64 Bridge over US 60.

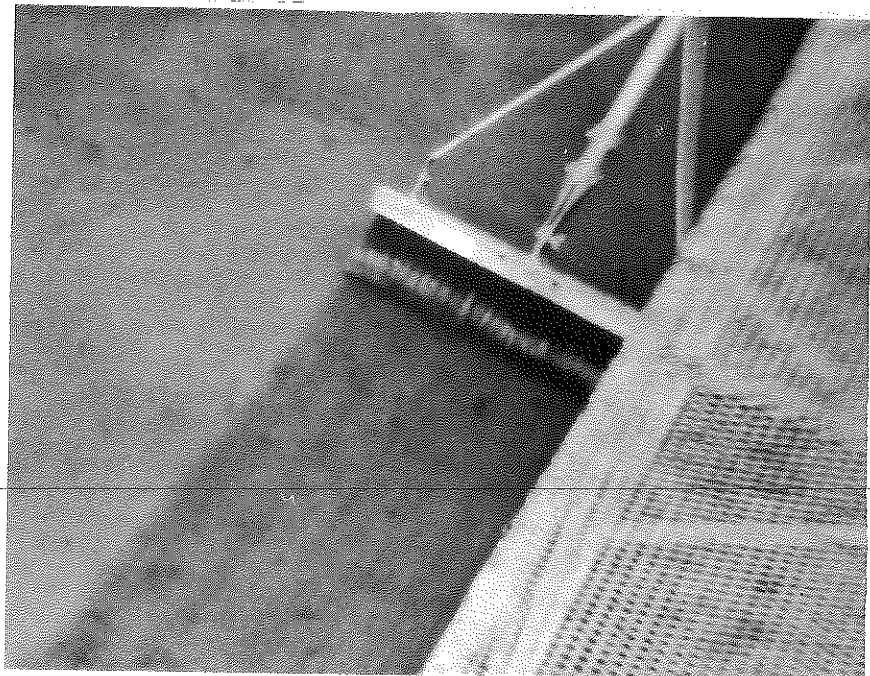

Figure 4. Circular, Vibratory Float Finishing Machine Being Used to Densify the Uppermost Portion of Deck; Eastbound, I-64 Bridge over US 60.

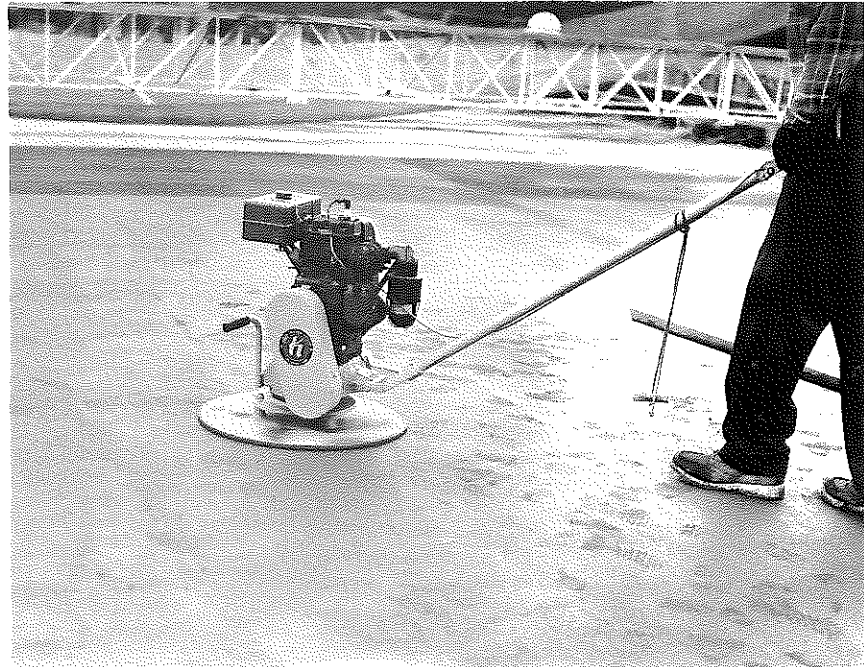

Figure 5. Finishing the First Layer of the Bi-Layered Deck.



Figure 6. Spreading Grout Coat on First Lift of Bi-Layered Deck.

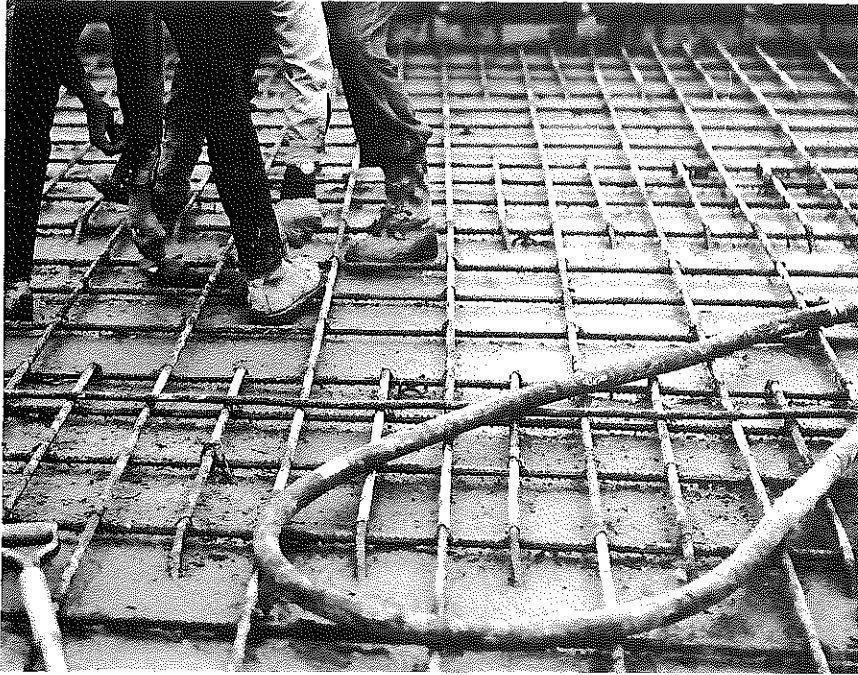

Figure 7. Placement of the Second Lift of the Bi-Layered Deck.





Figure 8. Corrosion Potential Testing Apparatus.

TABLE 1

TEST DATA FOR FIELD CYLINDERS

NO.	BRIDGE		LANES	STATION	IDENTIFICATION NUMBER	28-DAY COMPRESSIVE STRENGTH		MEASURED AIR CONTENT		SLUMP					
	LOCATION					(psi)	(MPa)	(percent)	(inches)	(mm)					
1	I 64 over US 60	WB	2632 + 69.25	11A	6895	47.5	6.1	3.0	7.6						
				12A	6580	45.4	6.1	3.0	7.6						
				13A	5375	37.1	7.1	3.5	8.9						
				14A	5800	40.0	7.1	3.5	8.9						
				15A	6190	42.7	6.0	3.5	8.9						
				16A	5800	40.0	6.0	3.5	8.9						
				17A	5300	35.9	6.1	3.5	8.9						
				18A	5480	37.8	6.1	3.5	8.9						
				19A	5480	37.8	6.1	3.5	8.9						
		EB	2632 + 69.25	31A	6545	45.1	5.5	3.5	8.9						
				31C	4845	33.4	5.5	3.3	8.4						
				32A	6895	47.5	5.9	3.0	7.6						
				32C	4740	32.7	5.9	3.0	7.6						
				33A	5020	34.6	5.5	3.0	7.6						
				38A	5020	34.6	5.1	2.0	5.1						
				39A	6455	44.5	5.5	2.0	5.1						
				39C	7980	55.0	5.5	2.0	5.1						
				2	Ducker's Road over I 64		2719 + 70.01	5A	5335	36.1	6.3	3.5	8.9		
								5C	5410	37.3	6.3	3.5	8.9		
5E	5055	34.9	6.7					3.0	7.6						
5G	5835	40.2	6.7					3.0	7.6						
5I	5020	34.6	6.7					3.5	8.9						
3	I 64 over Woodlake Road	WB	2835 + 83.07					11A	5765	39.7	6.0	2.5	6.4		
								11C	6545	45.1	6.0	2.5	6.4		
								11E	6365	43.9	5.8	3.0	7.6		
								11G	5305	36.6	5.7	2.8	7.1		
								11I	6080	41.9	5.7	3.0	7.6		
		EB	2834 + 83.07					11K	5695	39.3	5.8	2.8	7.1		
								11M	6045	41.7	6.0	2.5	6.4		
								13A	6155	42.4	5.5	3.3	8.4		
								13C	5905	40.7	5.5	3.3	8.4		
								13E	6930	47.8	5.5	3.3	8.4		
4	I 64 over US 421	WB	3007 + 66.5					57A	5910	40.7	5.7	3.0	7.6		
								57C	6260	43.2	5.5	3.0	7.6		
								58A	5980	41.2	4.1	3.5	8.9		
								58C	6200	42.7	5.0	3.5	8.9		
		EB	3007 + 66.5	59A	5380	37.1	8.0	3.5	8.9						
				34A	6860	47.3	6.8	2.0	5.1						
				34C	6760	46.6	6.8	2.0	5.1						
				34E	7110	49.0	6.8	2.0	5.1						
				37A	6680	46.1	7.0	2.5	6.4						
5	KY 341 over I 64		3023 + 50	21A	5520	38.1	6.5	2.5	6.4						
				21C	6050	41.7	7.0	2.8	7.1						
				22A	6370	43.9	6.2	2.8	7.1						
				22C	6900	47.6	6.2	2.8	7.1						
				23A	6680	46.1	6.5	2.8	7.1						
				28A	7070	48.7	7.0	3.0	7.6						
				28C	6330	43.6	7.0	3.0	7.6						
				30A	7370	50.8	6.0	2.5	6.4						
				30C	7000	48.3	6.0	2.5	6.4						
				6	I 64 over Elkhorn Creek	WB	3120 + 47.75	1	4280	29.5	7.2	2.5	6.4		
20A	6790	46.8	7.2					2.0	5.1						
20C	5450	37.6	7.2					2.0	5.1						
20E	6680	46.1	4.6					3.0	7.6						
20G	6860	47.3	4.9					3.0	7.6						
8A	5480	37.8	6.6					2.8	7.1						
8B	5040	34.7	6.6					2.8	7.1						
EB	3120 + 47.75	8C	5835			40.2	6.6	2.8	7.1						
		8E	5590			38.5	5.4	2.8	7.1						
		8G	5835			40.2	5.4	2.8	7.1						
		7	Cane Run Road over I 64				3142 + 56.26	49A	6630	45.7	4.5	3.0	7.6		
								49C	4950	34.1	4.5	3.0	7.6		
								49E	5270	36.3	5.5	3.0	7.6		
								49G	6900	47.6	5.5	3.0	7.6		
49I	5940			41.0	5.8			3.0	7.6						
49K	6010			41.4	6.0			3.0	7.6						
8	US 62 over I 64				3217 + 48.87			10A	6190	42.7	6.2	2.5	6.4		
								10C	4845	33.4	6.2	2.5	6.4		
								11A	6010	41.4	6.2	2.5	6.4		
								11C	6435	44.4	6.2	2.5	6.4		
		12A	6010			41.4	6.2	2.5	6.4						
		12C	5870			40.5	6.2	2.5	6.4						
		13A	6630			45.7	6.5	2.8	7.1						
		13C	5975			41.2	6.5	2.8	7.1						
		14A	6540			45.1	6.5	2.8	7.1						
		14C	6260			43.2	6.5	2.5	6.4						
		15A	6120			42.2	7.0	2.8	7.1						
		15C	6435			44.4	7.0	2.8	7.1						
		9	Yarnallton Road over I 64				3364 + 75.49	28A	6650	45.9	5.3	3.5	8.9		
								28C	6120	42.2	5.3	3.5	8.9		
								29A	5690	39.2	6.0	3.0	7.6		
29C	6680			47.6	6.0			3.0	7.6						
30A	5480			37.8	5.2			3.0	7.6						
30C	5480			37.8	5.2			3.0	7.6						

TABLE 2

CONCRETE CORE TEST DATA

NO.	BRIDGE LOCATION	LANES	FINAL FINISH OF DECK	PERMEABILITY (10 ⁷ cm/min)	SPECIFIC GRAVITIES			MOISTURE ABSORPTION (percent)	VOID CONTENT (percent)		
					SATURATED SURFACE DRY	BULK	APPARENT		TOP	MIDDLE	BOTTOM
1	I 64 over US 60	WB	Conventional	26.90	2.33	2.23	2.49	4.6	5.7	4.6	3.8
		EB	Compacted, Broomed	5.20	2.39	2.27	2.59	5.6	2.1	2.3	3.5
2	Ducker's Road over I 64		Broomed	0.30	2.36	2.25	2.53	4.9	4.0	5.0	3.0
3	I 64 over Woodlake Road		Broomed	1.36	2.31	2.18	2.49	5.7	5.7	6.0	5.1
4	I 64 over US 421	WB	Broomed	0.17	2.34	2.21	2.53	5.8	4.5	4.0	4.4
		EB	Conventional	18.30	2.34	2.20	2.54	6.1	3.8	3.3	4.2
5	KY 341 over I 64	SB	Compacted, Broomed	1.54	2.33	2.22	2.51	5.2	4.5	7.6	3.9
		NB	Conventional	0.06	2.33	2.20	2.51	5.5	4.4	5.2	3.0
6	I 64 over Elkhorn Creek		Compacted, Broomed	1.01	2.32	2.20	2.53	5.9	4.2	5.8	4.2
7	Cane Run Road over I 64		Conventional	0.02	2.32	2.19	2.51	5.8	5.7	6.0	4.3
8	US 62 over I 64		Conventional	2.23	2.38	2.26	2.57	5.4	2.9	3.3	2.1
9	Yarmallon Road over I 64		Conventional	4.86	2.30	2.21	2.43	4.2	3.8	4.1	4.0

TABLE 3

SKID RESISTANCE DATA

NO.	BRIDGE LOCATION	LANE	FINAL FINISH OF DECK	DATE OPENED TO TRAFFIC	SKID NUMBERS									
					40 mph (17.9 m/s)	55 mph (24.6 m/s)	70 mph (31.3 m/s)	40 mph (17.9 m/s)	55 mph (24.6 m/s)	70 mph (31.3 m/s)				
1	I 64 over US 60	WBO	Conventional	8-29-73	4-3-73	5-16-73	9-7-73	4-8-74	4-8-78	9-12-78	35	27	24	
		WBI	Conventional								38	38	30	22
		EBO	Compacted, Broomed								59	43	37	44
		EBI	Compacted, Broomed								61	53	43	41
2	Ducker's Road over I 64	NB	Broomed								55	53	57	
		SB	Broomed								59	52	58	
3	I 64 over Woodlake Road	WBO	Broomed	8-29-73							54	52	46	
		WBI	Broomed								61	51	39	37
		EBO	Broomed								52	43	35	38
		EBI	Broomed								61	50	40	39
4	I 64 over US 421	WBO	Broomed	8-29-73							60	48	45	
		WBI	Broomed								69	59	54	52
		EBO	Conventional								40	33	25	28
		EBI	Conventional								41	40	32	27
5	KY 341 over I 64	NB	Conventional	4-25-72	44	46	42	41			54	54	53	
		SB	Compacted, Broomed								54	54	57	53
6	I 64 over Elkhorn Creek	WBO	Compacted, Broomed	8-29-73							52	39	36	
		WBI	Compacted, Broomed								58	49	38	38
		EBO	Compacted, Broomed								52	35	29	31
		EBI	Compacted, Broomed								52	44	39	33
7	Cane Run Road over I 64	NB	Conventional	6-7-72							43	40	40	
		SB	Conventional								41	40	40	
8	US 62 over I 64	WB	Conventional	12-8-71	33	48	45	43	38	37	42	41	43	
		EB	Conventional								42	41	43	37
9	Yarmallon Road over I 64	NB	Conventional	6-15-72	39	38	40	40			32	44	45	
		SB	Conventional								32	44	45	

APPENDIX A
BRIDGE-BY-BRIDGE INFORMATION

**BRIDGE 1
I 64 OVER US 60**

Type of Construction -- continuous composite plate girder; EB: bi-layered deck
Special Provision Nos. -- 12, 30B, 35B, 77B, 8A, 79, 80A
Date of Pour -- EB Lift #1: Oct 6, 1971; EB Lift #2: Oct 21, 25, 26, 1971; WB: Aug 6, 10, 11, 12, 1971
Resident Engineer -- H. Gabbard
Inspector -- D. Carter
Superintendent -- J. Q. Spurlin
Contractor -- Dawson Bridge Co.
Total Cost of Bridge -- \$474,139.26 (EB and WB)
Deck Cost -- \$48,483.00 (EB)
Cost of Equivalent Conventional Deck -- \$40,557.00 (WB)
Bridge Dimensions --
Slab Thickness: 7 1/2" (19 cm)
Width (curb to curb): 39' 3" (11.96 m)
Length: 296' 5" (64.95 m)

CONCRETE DATA

Concrete Contractor -- Horn & Goin
Mixer Size -- 6 cu yd (4.59 m³)
Type of Mix -- transit
Order of Batching --
1. 3/4 of water plus air entrainer and retarder
2. sand
3. stone
4. cement
5. remaining water
Time of Mixing -- transit mix, 70 revolutions at plant
Delivery Truck --
Type: rotary drum
Size: 7 cu yd (5.35 m³)
Agitation Time -- slow speed to job site
Mix Time on Job -- 30 revolutions at mixing speed
How Deposited on Deck -- crane
Finishing Machine -- Bidwell
Final Finish -- EB: compacted and broomed; WB: conventional
Curing -- curing compound and wet burlap for 7 days
Depth of Top of Steel -- 2" (5 cm)
How Elevation to Top of Steel Checked -- from deck by instrument
Did Workmen Walk in Fresh Concrete -- sometimes

MATERIALS (SOURCE AND(OR) TYPE)

Aggregate -- Capital Stone
Sand -- Appalachian Sand
Water -- Local (Frankfort)
Cement -- Louisville Cement
Entraining Agent -- Master Builders MBVR
Retarder -- Sika Plastiment

**BRIDGE 2
DUCKER'S ROAD OVER I 64**

Type of Construction -- continuous reinforced concrete deck girder
Special Provision Nos. -- 30B, 35B, 77B, 12, 8A, 79, 80A
Date of Pour -- Aug 9, 1971
Resident Engineer -- H. Gabbard
Inspectors -- C. Combs, R. E. Niekirk
Superintendent -- D. Vernon
Contractor -- Nally & Thompson
Total Cost of Bridge -- \$162,160.74
Deck Cost -- \$67,752.00
Cost of Equivalent Conventional Deck -- \$29,500.00 (est.)
Bridge Dimensions --
Slab Thickness: 7 1/2" (19 cm)
Width (curb to curb): 28' 0" (8.53 m)
Length: 278' 6" (84.89 m)

CONCRETE DATA

Concrete Contractor -- Harrod-Carter
Mixer Size -- 7 cu yd (5.35 m³)
Type of Mix -- transit
Order of Batching --
1. 3/4 water plus air entrainer and retarder
2. sand
3. stone
4. cement
5. remaining water
Time of Mixing -- transit mix, 70 revolutions at plant
Delivery Truck --
Type: rotary drum
Size: 7 cu yd (5.35 m³)
Agitation Time -- slow speed to job site
Mix Time on Job -- 30 revolutions at mixing speed
How Deposited on Deck -- crane
Finishing Machine -- Bidwell
Final Finish -- broomed
Curing -- curing compound and wet burlap for 7 days
Depth of Top of Steel -- 2" (5 cm)
How Elevation to Top of Steel Checked -- from deck by instrument
Did Workman Walk in Fresh Concrete -- sometimes

MATERIALS (SOURCE AND(OR) TYPE)

Aggregate -- Harrod-Carter Quarry
Sand -- Dreyer, Whitehead, Goedecke Sand
Water -- Local (Frankfort)
Cement -- Lehigh Cement
Entraining Agent -- Master Builders MBVR
Retarder -- Master Builders 300 R

BRIDGE 3
I 64 OVER WOODLAKE ROAD

Type of Construction -- continuous flat slab
Special Provision Nos. -- 77B, 79, 35B, 80A, 30A
Date of Pour -- EB: Oct 28, 1971; WB: Oct 18, 1971
Resident Engineer -- H. Gabbard
Inspectors -- J. Deaton, R. E. Niekirk
Superintendent -- D. Vernon
Contractor -- Nally & Thompson
Total Cost of Bridge -- \$158,060.12
Deck Cost -- \$20,160.00
Bridge Dimensions --
 Slab Thickness: 1' 4" (40.6 cm)
 Width (curb to curb): 39' 3" (11.96 m)
 Length: 121' 6" (37.03 m)

CONCRETE DATA

Concrete Contractor -- Harrod-Carter
Mixer Size -- 7 cu yd (5.35 m³)
Type of Mix -- transit
Order of Batching --
 1. 3/4 water plus air entrainer and retarder
 2. sand
 3. stone
 4. cement
 5. remaining water
Time of Mixing -- transit mix, 70 revolutions at plant
Delivery Truck --
 Type: rotary drum
 Size: 7 cu yd (5.35 m³)
Agitation Time -- slow speed to job site
Mix Time on Job -- 30 revolutions at mixing speed
How Deposited on Deck -- crane
Finishing Machine -- Bidwell
Final Finish -- broomed
Curing -- curing compound and wet burlap for 7 days
Depth of Top of Steel -- 2" (5 cm)
How Elevation to Top of Steel Checked -- from deck
 by instrument
Did Workmen Walk in Fresh Concrete -- sometimes

MATERIALS (SOURCE AND(OR) TYPE)

Aggregate -- Harrod-Carter Quarry
Sand -- Dreyer, Whitehead, Goedecke Sand
Water -- Local (Frankfort)
Cement -- Lehigh Cement
Entraining Agent -- Master Builders MBVR
Retarder -- Master Builders 300R

BRIDGE 4
I 64 OVER US 421

Type of Construction -- continuous plate girder
Special Provision Nos. -- 30B, 35B, 37B, 77B, 12, 8A,
 79, 80A
Date of Pour -- WB: Jun 5, 7, 8, 1971; EB: Apr 3,
 5, 11, 1972
Resident Engineer -- H. Gabbard
Inspectors -- R. E. Niekirk, A. Justice
Superintendent -- D. Vernon
Contractor -- Nally & Thompson
Total Cost of Bridge -- \$452,221.57
Deck Cost -- \$36,012.00 (WB)
Cost of Equivalent Conventional Deck -- 36,012.00 (EB)
Bridge Dimensions --
 Slab Thickness: 7 1/2" (19 cm)
 Width (curb to curb): 39' 3" (11.96 m)
 Length: 243' 6 3/8" (74.23 m)

CONCRETE DATA

Concrete Contractor -- Congleton
Mixer Size -- 7 cu yd (5.35 m³)
Type of Mix -- central batch
Order of Batching --
 Water containing agent and retarder begins flowing
 into drum. When drum is wet, sand begins flowing,
 followed by stone, then cement. Flows stop in
 reverse order.
Time of Mixing -- 2 minutes at plant
Delivery Truck --
 Type: rotary drum
 Size: 8 cu yd (6.12 m³)
Agitation Time -- slow speed to job site
Mix Time on Job -- 30 revolutions
How Deposited on Deck -- crane
Finishing Machine -- Bidwell
Final Finish -- WB: broomed; EB: conventional
Curing -- curing compound and wet burlap for 7 days
Depth of Top of Steel -- 2" (5 cm)
How Elevation to Top of Steel Checked -- from deck
 by instrument
Did Workmen Walk in Fresh Concrete -- sometimes

MATERIALS (SOURCE AND(OR) TYPE)

Aggregate -- Vulcan Materials
Sand -- Concrete Materials
Water -- Local (Lexington)
Cement -- Louisville Cement
Entraining Agent -- CONVX
Retarder -- Master Builders 300R

BRIDGE 5
KY 341 OVER I 64

Type of Construction -- continuous reinforced concrete deck girder
Special Provision Nos. -- 77B, 12, 30B, 35B, 8A, 79, 80A
Date of Pour -- Jan 24, 1972; Feb 15, 1972; Mar 7, 11, 16, 1972
Resident Engineer -- H. Gabbard
Inspectors -- Combs, Justice, Fernandez
Superintendent -- D. Vernon
Contractor -- Nally & Thompson
Total Cost of Bridge -- \$300,777.32
Deck Cost -- \$70,098.00
Bridge Dimensions --
 Slab Thickness: 7 1/2" (19 cm)
 Width (curb to curb): 64' 0" (19.51 m)
 Length: 276' 6" (84.28 m)

CONCRETE DATA

Concrete Contractor -- Congleton
Mixer Size -- 7 cu yd (5.35 m³)
Type of Mix -- central batch
Order of Batching --
 Water containing air entraining agent and retarder begins flowing into drum. When drum is wet, sand begins flowing, followed by stone, then cement. Flows stop in reverse order.
Time of Mixing -- 2 minutes at plant
Delivery Truck --
 Type: rotary drum
 Size: 8 cu yd (6.12 m³)
Agitation Time -- slow speed to job site
Mix Time on Job -- 30 revolutions at mixing speed
How Deposited on Deck -- crane
Finishing Machine -- Bidwell
Final Finish -- SB: compacted and broomed; NB: conventional
Curing -- curing compound and wet burlap for 7 days
Depth of Top of Steel -- 2" (5 cm)
How Elevation to Top of Steel Checked -- from deck by instrument
Did Workmen Walk in Fresh Concrete -- sometimes

MATERIALS (SOURCE AND(OR) TYPE)

Aggregate -- Vulcan Materials
Sand -- Concrete Materials
Water -- Local (Lexington)
Cement -- Louisville Cement
Entraining Agent -- CONVX
Retarder -- none

BRIDGE 6
I 64 OVER ELKHORN CREEK

Type of Construction -- continuous wide flange girder
Special Provision Nos. -- 12, 8A, 35, 30B, 77B, 79, 80A
Date of Pour -- EB: Nov 13, 1971; WB: Jan 18, 1972
Resident Engineer -- H. Gabbard
Inspectors -- Deaton, Combs
Superintendent -- D. Vernon
Contractor -- Nally & Thompson
Total Cost of Bridge -- \$296,171.26
Deck Cost -- \$24,276.00
Cost of Equivalent Conventional Deck -- \$24,276.00
Bridge Dimensions --
 Slab Thickness: 7 1/2" (19 cm)
 Width (curb to curb): 39' 3" (11.96 m)
 Length: 161' 4" (49.17 m)

CONCRETE DATA

Concrete Contractor -- Congleton
Mixer Size -- 7 cu yd (5.35 m³)
Type of Mix -- central batch
Order of Batching --
 Water containing air entraining agent and retarder begins flowing into drum. When drum is wet, sand begins flowing, followed by stone, then cement. Flows stop in reverse order.
Time of Mixing -- 2 minutes at plant
Delivery Truck --
 Type: rotary drum
 Size: 8 cu yd (6.12 m³)
Agitation Time -- slow speed to job site
Mix Time on Job -- 30 revolutions at mixing speed
How Deposited on Deck -- crane
Finishing Machine -- Bidwell
Final Finish -- compacted and broomed
Curing -- curing compound and wet burlap for 7 days
Depth of Top of Steel -- 2" (5 cm)
How Elevation to Top of Steel Checked -- from deck by instrument
Did Workmen Walk in Fresh Concrete -- sometimes

MATERIALS (SOURCE AND(OR) TYPE)

Aggregate -- Vulcan Materials
Sand - Concrete Materials
Water -- Local (Lexington)
Cement -- Louisville Cement
Entraining Agent - CONVX
Retarder -- Master Builders 300R

BRIDGE 7
CANE RUN ROAD OVER I 64

Type of Construction -- continuous composite plate girder
Special Provision Nos. -- 30B, 35B, 77B, 12, 8A, 79, 80A
Date of Pour -- May 4, 1972
Resident Engineer -- H. Gabbard
Inspectors -- Combs, Fernandez
Superintendent -- D. Vernon
Contractor -- Nally & Thompson
Total Cost of Bridge -- \$195,523.92
Deck Cost -- \$21,798.00
Bridge Dimensions --
 Slab Thickness: 8" (20 cm)
 Width (curb to curb): 28' 0" (8.53 m)
 Length: 349' 2" (106.43 m)

CONCRETE DATA

Concrete Contractor -- Congleton
Mixer Size -- 7 cu yd (5.35 m³)
Type of Mix -- central batch
Order of Batching --
 Water containing air entraining agent and retarder begins flowing into drum. When drum is wet, sand begins flowing, followed by stone, then cement. Flows stop in reverse order.
Time of Mixing -- 2 minutes at plant
Delivery Truck --
 Type: rotary drum
 Size: 8 cu yd (6.12 m³)
Agitation Time -- slow speed to job site
Mix Time on Job -- 30 revolutions at mixing speed
How Deposited on Deck -- crane
Finishing Machine Name -- Bidwell
Final Finish -- conventional
Curing -- curing compound and wet burlap for 7 days
Depth of Top of Steel -- 2" (5 cm)
How Elevation to Top of Steel Checked -- from deck by instrument
Did Workmen Walk in Fresh Concrete -- sometimes

MATERIALS (SOURCE AND(OR) TYPE)

Aggregate -- Vulcan Materials
Sand -- Concrete Materials
Water -- Local (Lexington)
Cement -- Louisville Cement
Entraining Agent -- CONVX
Retarder -- Master Builders 300R

BRIDGE 8
US 62 OVER I 64

Type of Construction -- continuous reinforced concrete deck girder
Special Provision Nos. -- 77B, 30B, 35B, 12, 8A, 79, 80A
Date of Pour -- Oct 13, 14, 15, 28, 29, 1971; Nov 1, 1971
Resident Engineer -- H. Gabbard
Inspectors -- Deaton, Justice
Superintendent -- C. Bunch
Contractor -- Dawson Bridge Co.
Total Cost of Bridge -- \$320,091.29
Deck Cost -- \$68,345.55
Bridge Dimensions --
 Slab Thickness: 7 1/2" (19 cm)
 Width (curb to curb): 64' 0" (19.51 m)
 Length: 276' 6" (84.28 m)

CONCRETE DATA

Concrete Contractor -- Congleton
Mixer Size -- 7 cu yd (5.35 m³)
Type of Mix -- central batch
Order of Batching --
 Water containing air entraining agent and retarder begins flowing into drum. When drum is wet, sand begins flowing, followed by stone, then cement. Flows stop in reverse order.
Time of Mixing -- 2 minutes at plant
Delivery Truck --
 Type: rotary drum
 Size: 8 cu yd (6.12 m³)
Agitation Time -- slow speed to job site
Mix Time on Job -- 30 revolutions at mixing speed
How Deposited on Deck -- crane
Finishing Machine Name -- Bidwell
Final Finish -- conventional
Curing -- curing compound and wet burlap for 7 days
Depth of Top of Steel -- 2" (5 cm)
How Elevation to Top of Steel Checked -- from deck by instrument
Did Workmen Walk in Fresh Concrete -- sometimes

MATERIALS (SOURCE AND(OR) TYPE)

Aggregate -- Vulcan Materials
Sand -- Concrete Materials
Water -- Local (Lexington)
Cement -- Louisville Cement
Entraining Agent -- CONVX
Retarder -- none

BRIDGE 9
YARNALLTON ROAD OVER I 64

Type of Construction -- continuous reinforced concrete
deck girder
Special Provision Nos. -- 77B, 30B, 35B, 12, 8A, 79,
80A
Date of Pour -- May 10, 11, 12, 1972
Resident Engineer -- H. Gabbard
Inspector - Deaton
Superintendent -- C. Bunch
Contractor -- Dawson Bridge Co.
Total Cost of Bridge -- \$191,269.91
Deck Cost -- \$42,371.55
Bridge Dimensions --
 Slab Thickness: 7 1/2" (19 cm)
 Width (curb to curb): 28' 0" (8.53 m)
 Length: 322' 2" (98.20 m)

CONCRETE DATA

Concrete Contractor -- Congleton
Mixer Size -- 7 cu yd (5.35 m³)
Type of Mix -- central batch
Order of Batching --
 Water containing air entraining agent and retarder
 begins flowing into drum. When drum is wet, sand
 begins flowing followed by stone then cement. The
 flows stop in the reverse order.
Time of Mixing -- 2 minutes at plant
Delivery Truck --
 Type: rotary drum
 Size: 8 cu yd (6.12 m³)
Agitation Time -- slow speed to job site
Mix Time on Job -- 30 revolutions at mixing speed
How Deposited on Deck -- crane
Finishing Machine Name -- Bidwell
Final Finish -- conventional
Curing -- curing compound and wet burlap for 7 days
Depth of Top of Steel -- 2" (5 cm)
How Elevation to Top of Steel Checked -- from deck
 by instrument
Did Workmen Walk in Fresh Concrete -- sometimes

MATERIALS (SOURCE AND/OR) TYPE)

Aggregate -- Vulcan Materials
Sand -- Concrete Materials
Water -- Local (Lexington)
Cement -- Louisville Cement
Entraining Agent -- CONVX
Retarder -- None

APPENDIX B
EQUIRESISTANCE CONTOUR MAPS

Eastbound bridge on I 64 over US 60 near Frankfort. A continuous composite plate girder with a bi-layered deck, completed October 26, 1971. Electrical tests completed June 1973. (Readings are in million-ohms.)

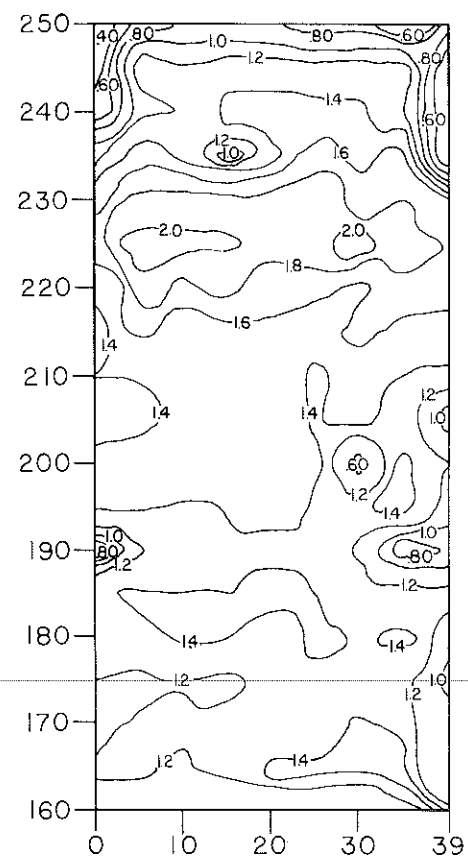
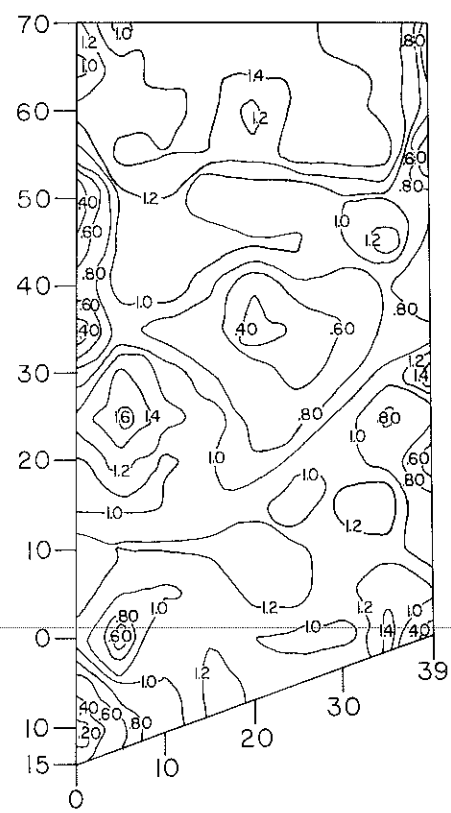
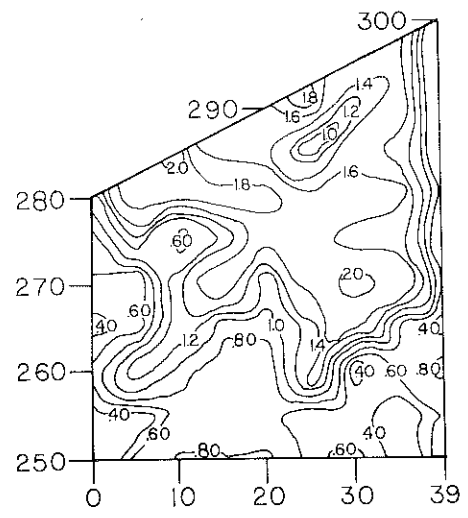
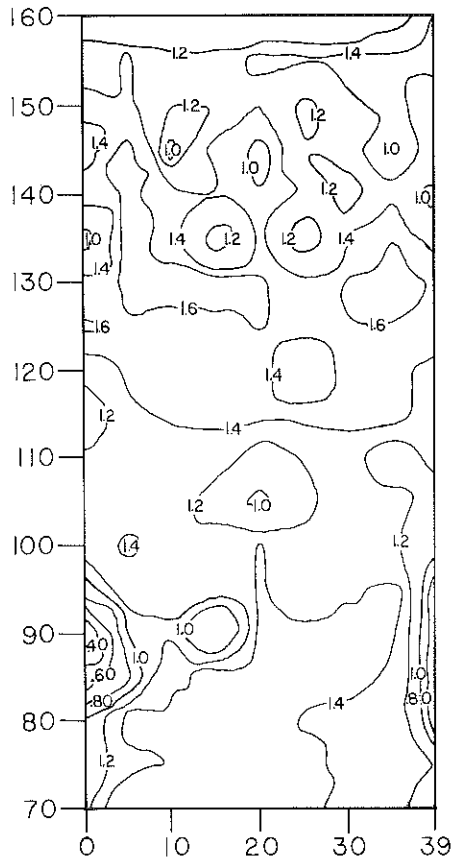

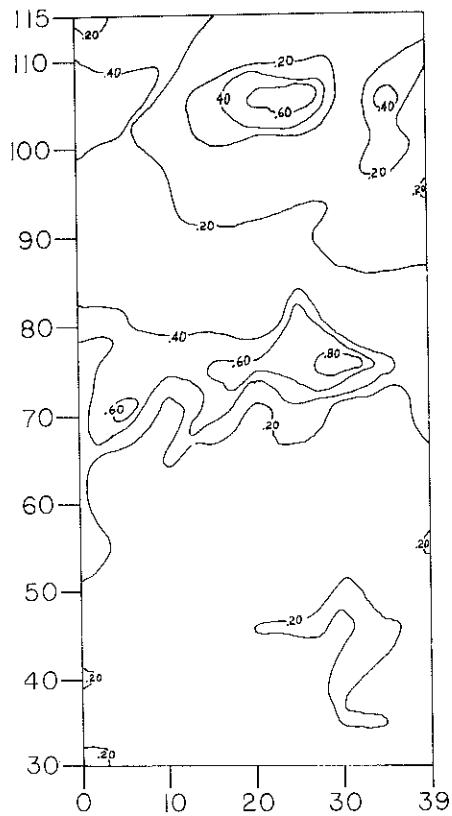

Eastbound bridge on I 64 over US 421 near Midway. A continuous plate girder deck, completed April 11, 1972. Electrical tests completed June 1973. (Readings are in million-ohms.)

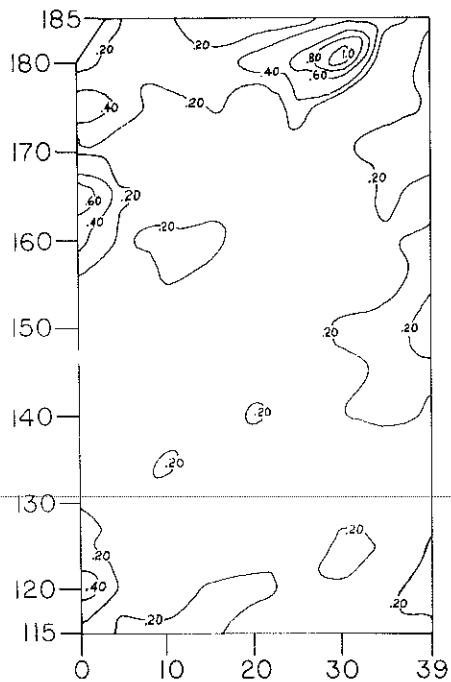
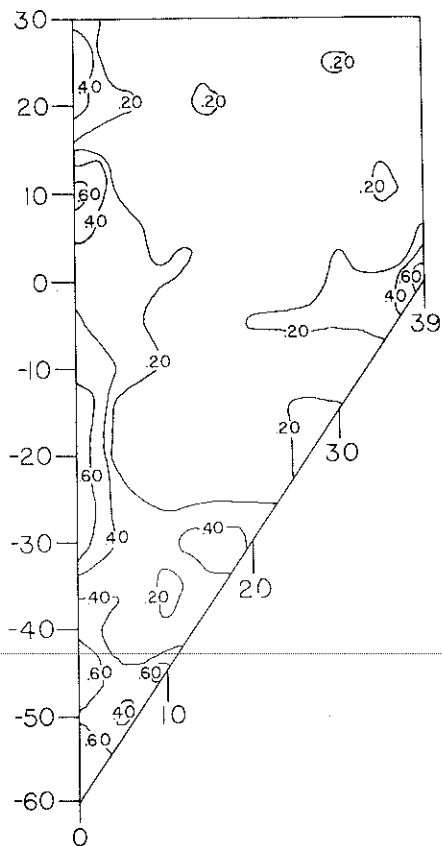
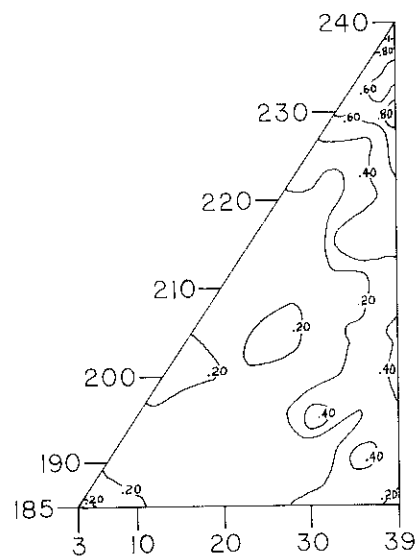

Eastbound bridge on I 64 over Elkhorn Creek. A continuous wide flange girder deck, completed November 13, 1971. Electrical tests completed June 1973. (Readings are in million-ohms.)

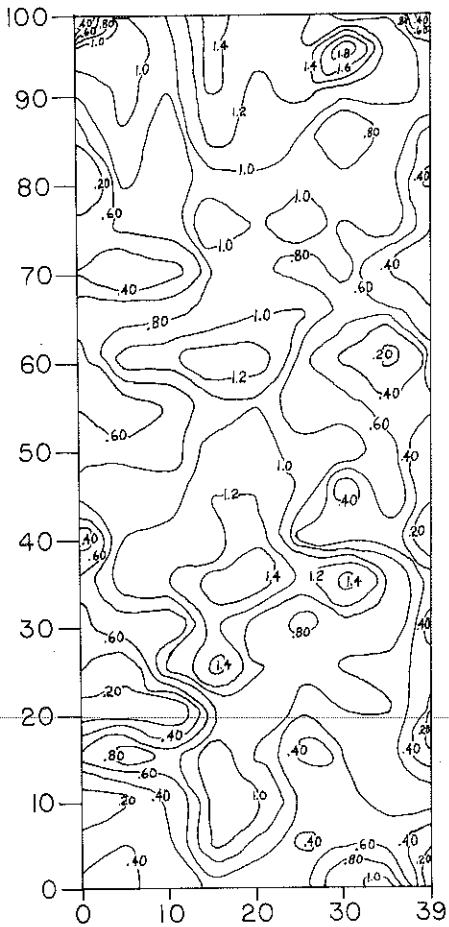
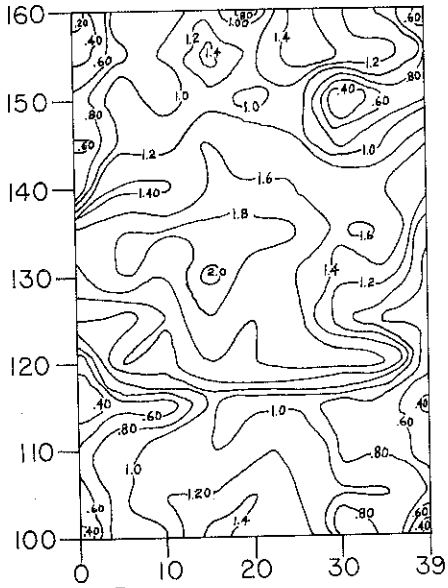

Bridge on Yarnallton Road over I 64. A continuous reinforced concrete deck girder, completed May 12, 1972. Electrical tests completed June 1973. (Readings are in million-ohms.)

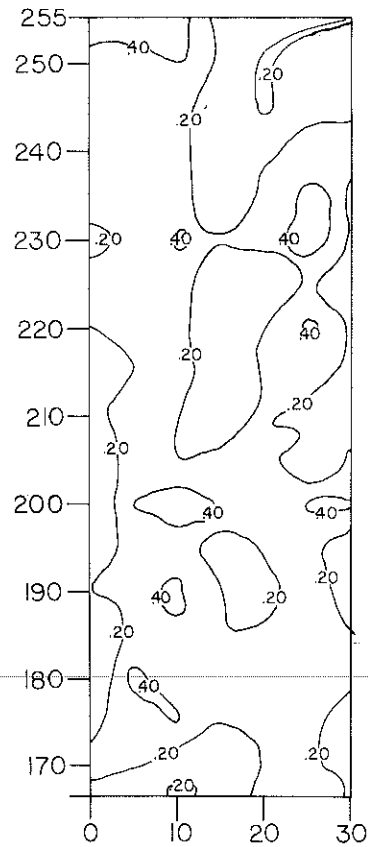
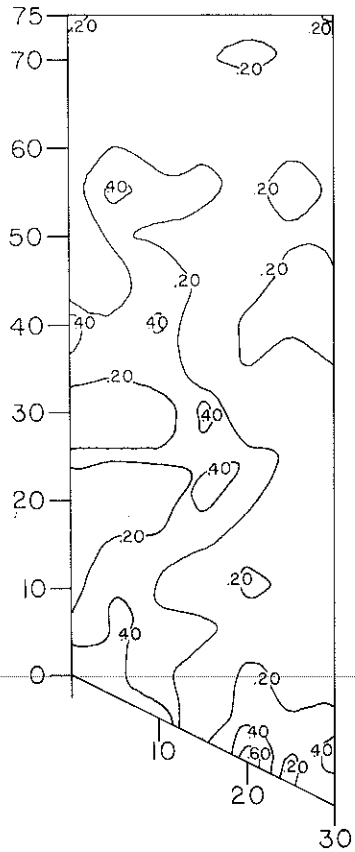
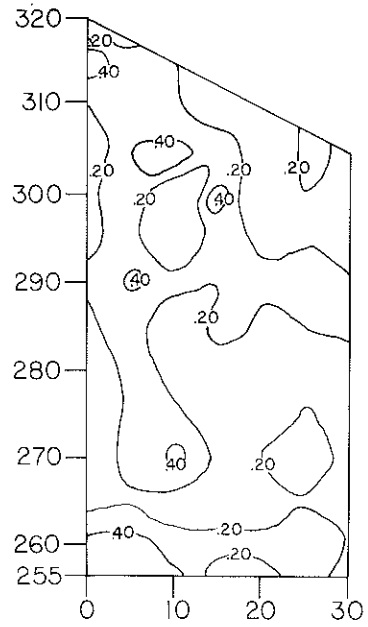
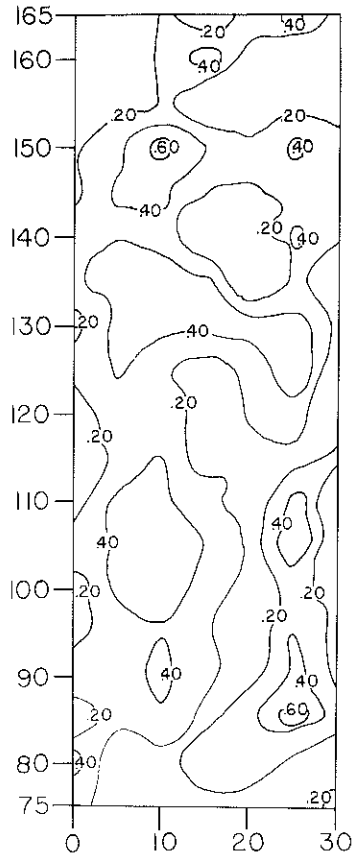

APPENDIX C
EQUIPOTENTIAL CONTOUR MAPS

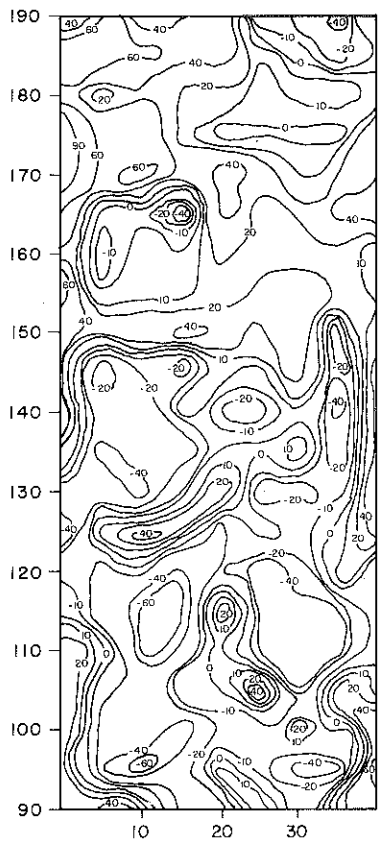

Westbound bridge on I 64 over US 60 near Frankfort. A continuous composite plate girder, completed August 12, 1971. Electrical tests, completed June 21, 1973, indicated no areas of active corrosion. (Readings are in millivolts.)

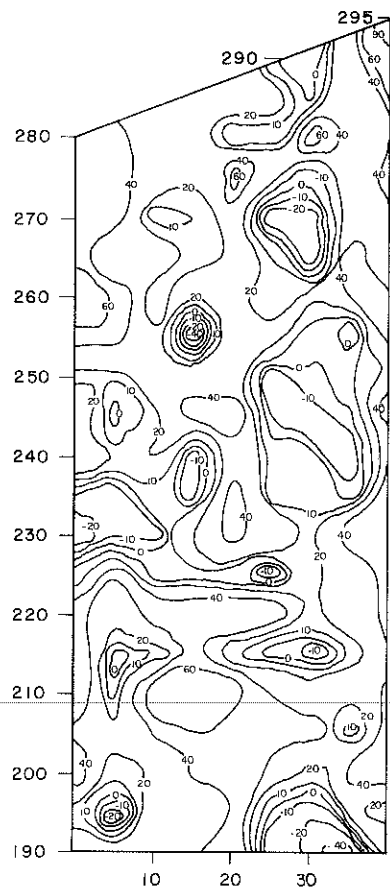
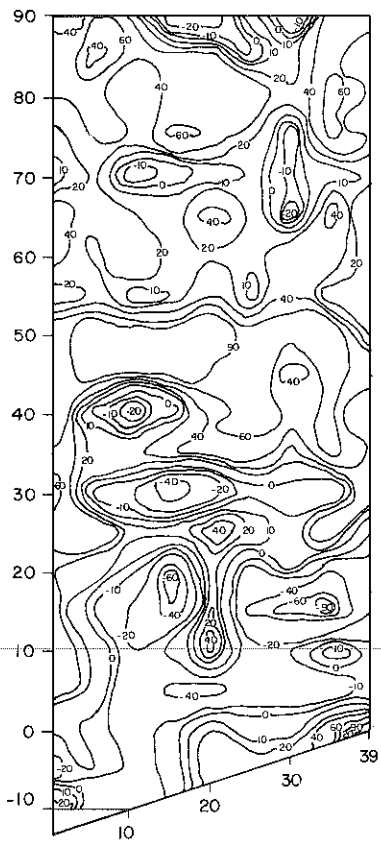

Eastbound bridge on I 64 over US 60 near Frankfort. A continuous composite plate girder with a bi-layer deck, completed October 26, 1971. Electrical tests, completed June 22, 1973, indicated no areas of active corrosion. (Readings are in millivolts.)

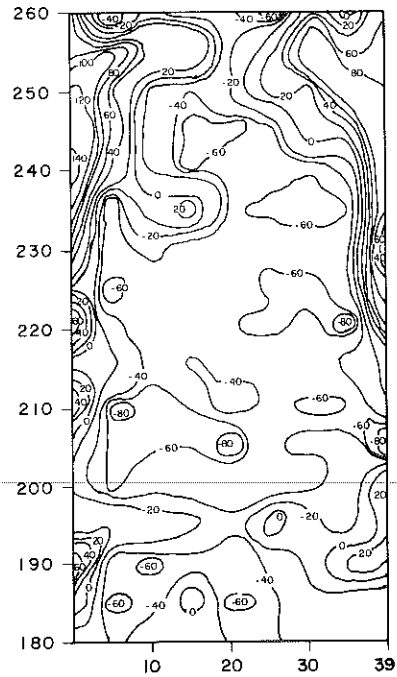
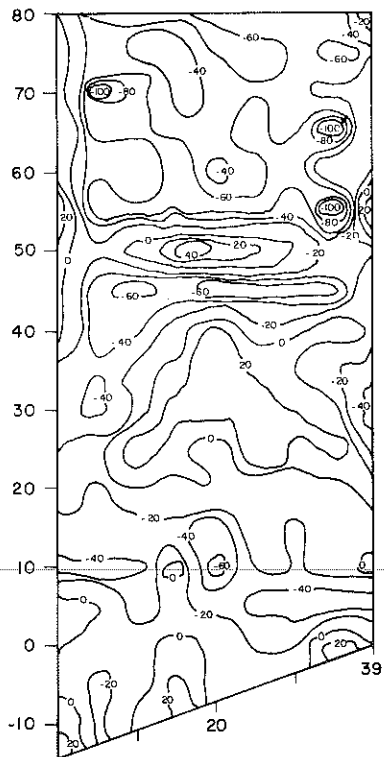
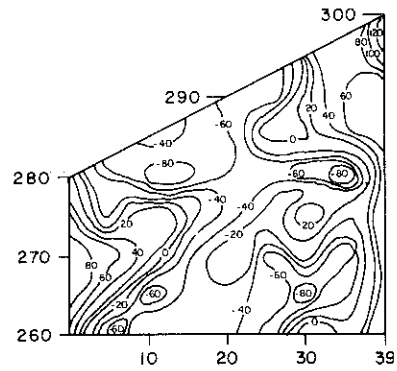
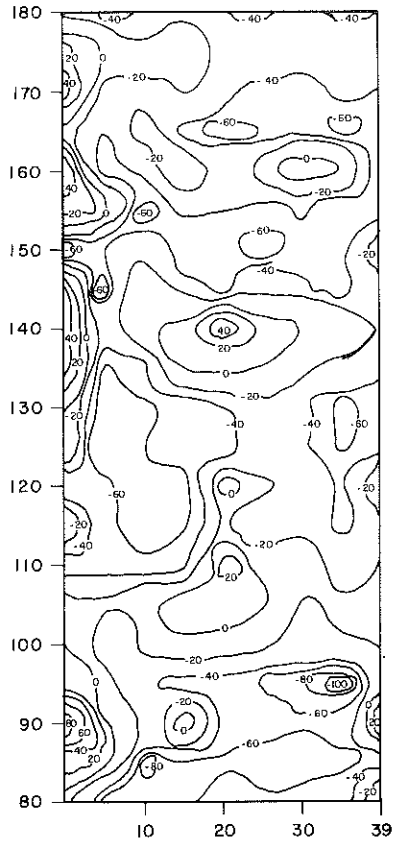

Eastbound bridge on I 64 over US 421 near Midway. A continuous plate girder deck, completed April 11, 1972. Electrical tests, completed June 25, 1973, indicated no areas of active corrosion. (Readings are in millivolts.)

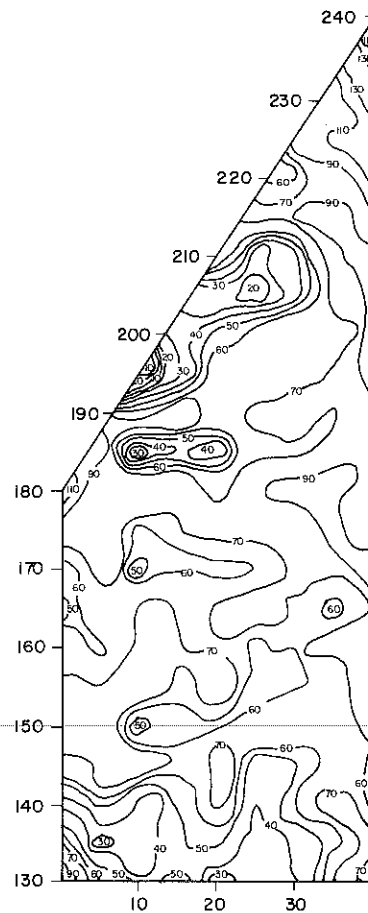
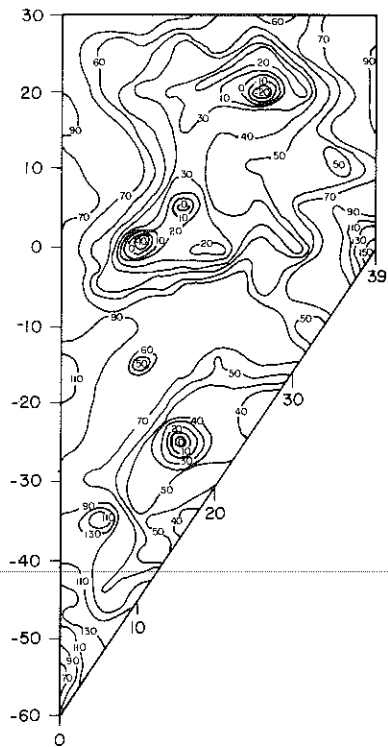
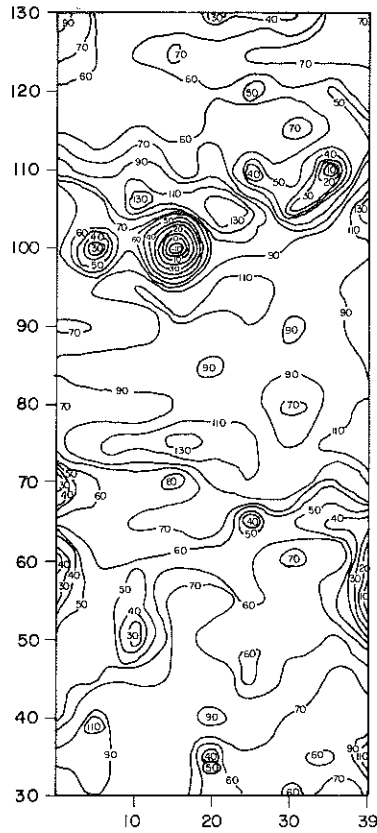

Bridge on Yarnallton Road over I 64. A continuous reinforced concrete deck girder, completed May 12, 1972. Electrical tests, completed June 18, 1973, indicated no areas of active corrosion. (Readings are in millivolts.)

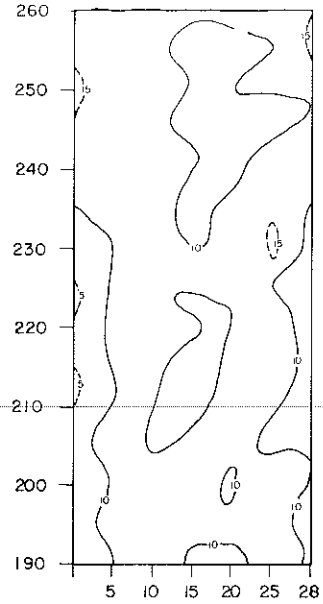
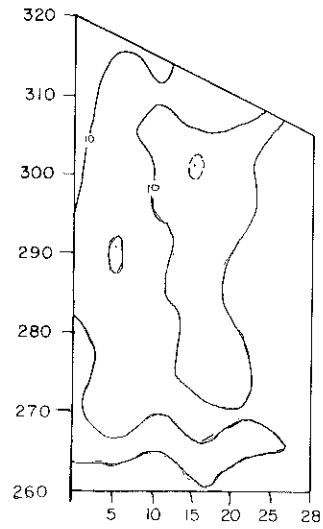
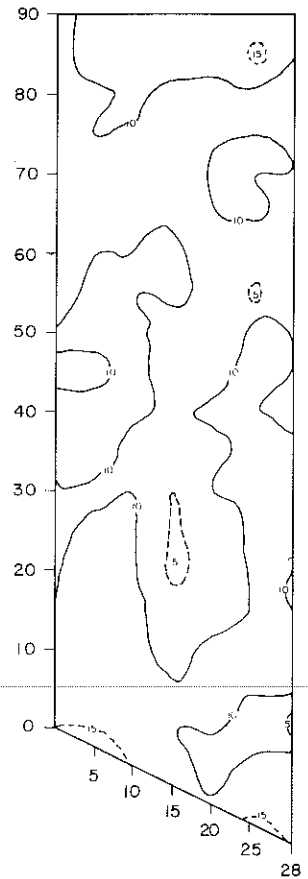
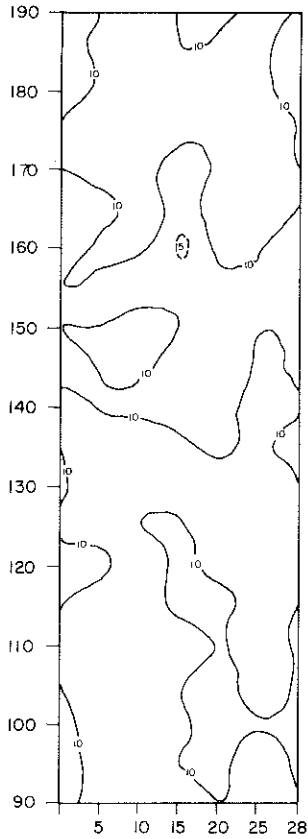

Eastbound bridge on I 64 over Elkhorn Creek. A continuous wide flange girder deck, completed November 13, 1971. Electrical tests, completed July 2, 1973, indicated no areas of active corrosion. (Readings are in millivolts.)

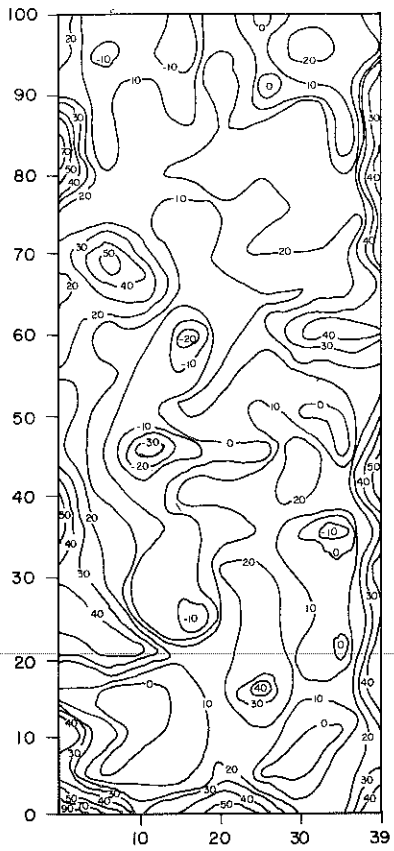
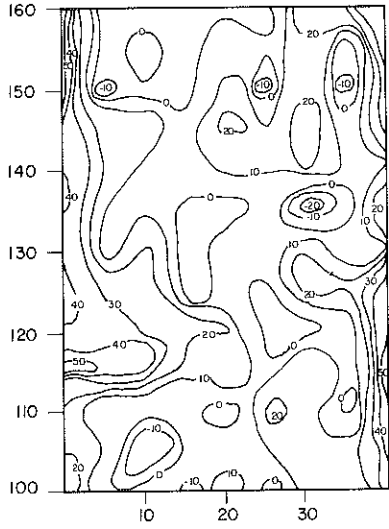

APPENDIX D
LOCATIONS OF CORES

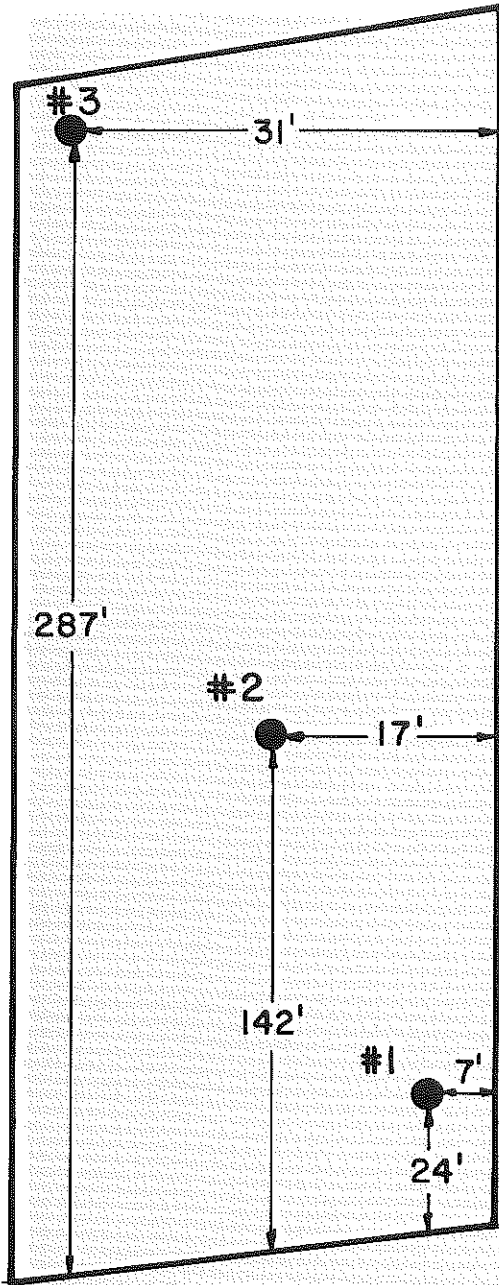

↓ EASTBOUND

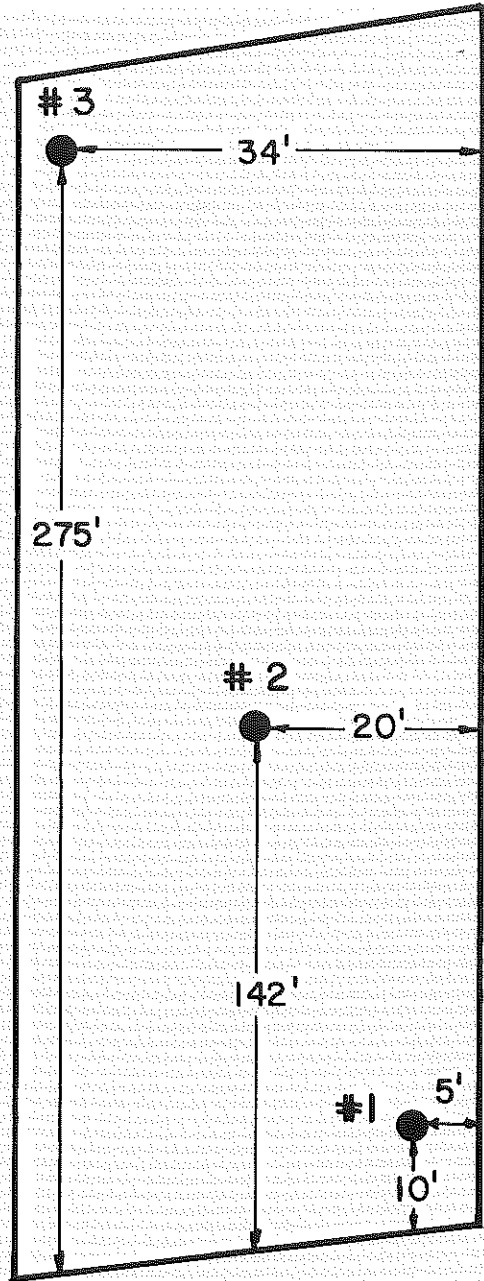

↑ WESTBOUND

BRIDGE 1
I 64 OVER US 60

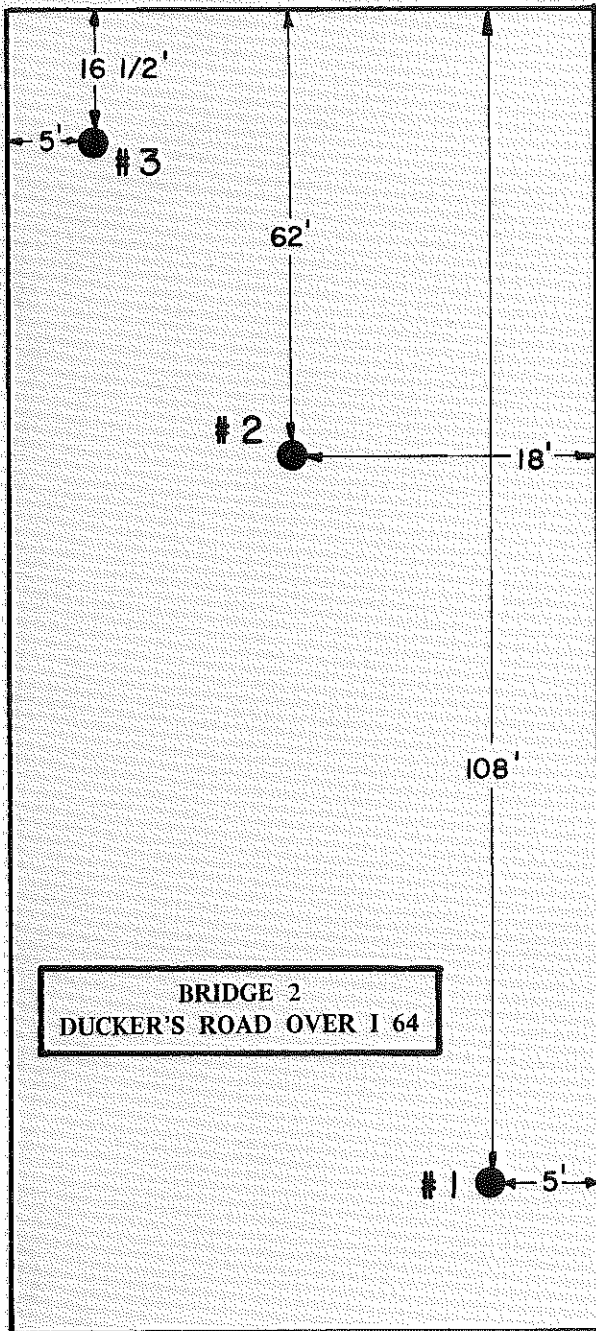

BRIDGE 2
DUCKER'S ROAD OVER I 64

BRIDGE 3
I 64 OVER WOODLAKE ROAD

↑ WESTBOUND

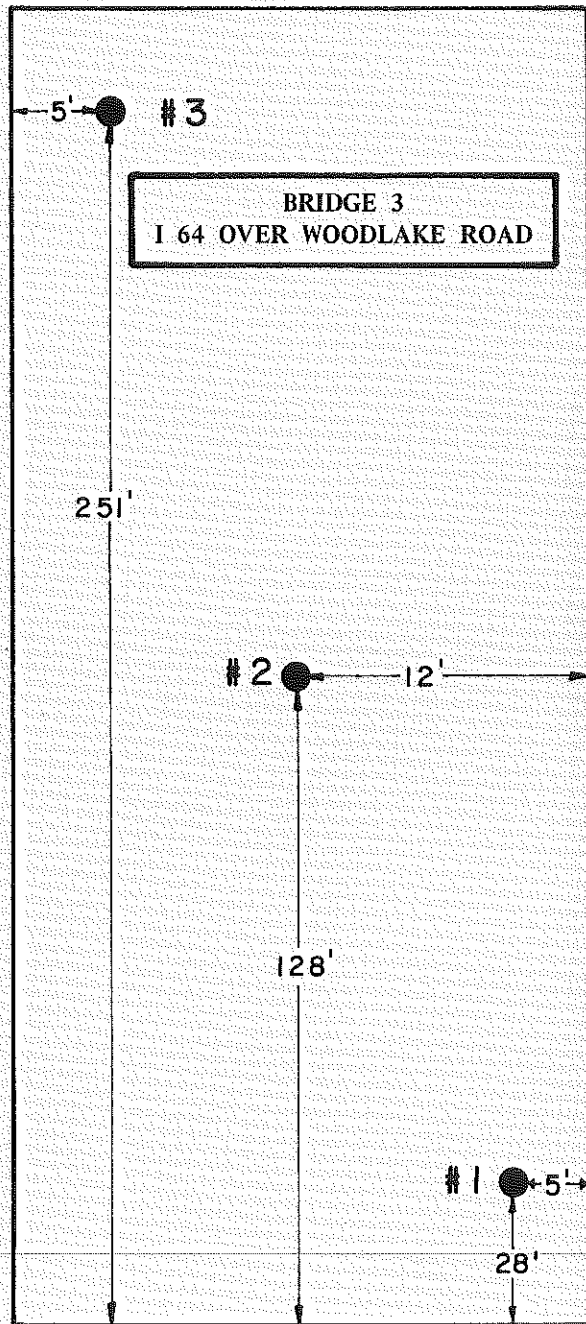

↑ NORTHBOUND

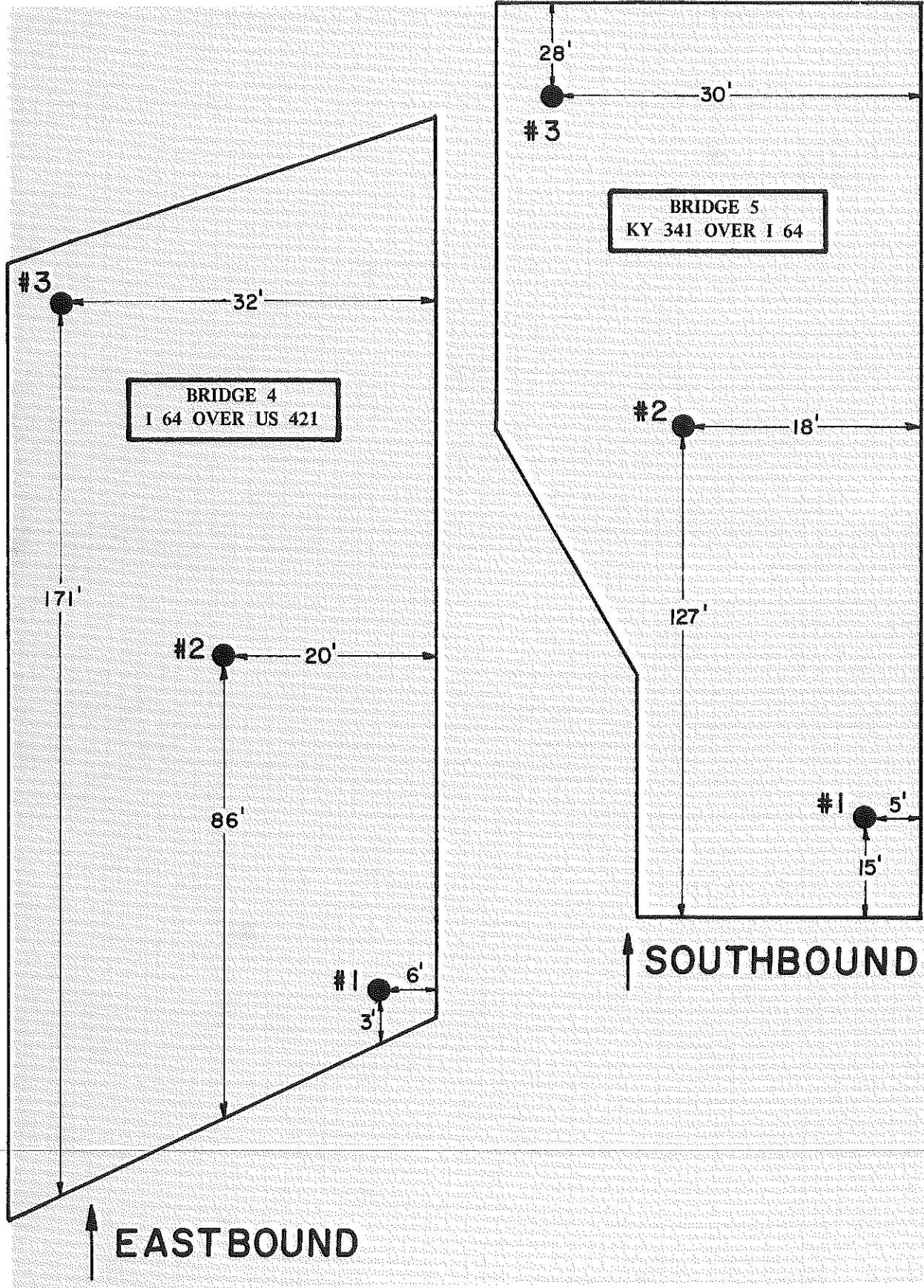

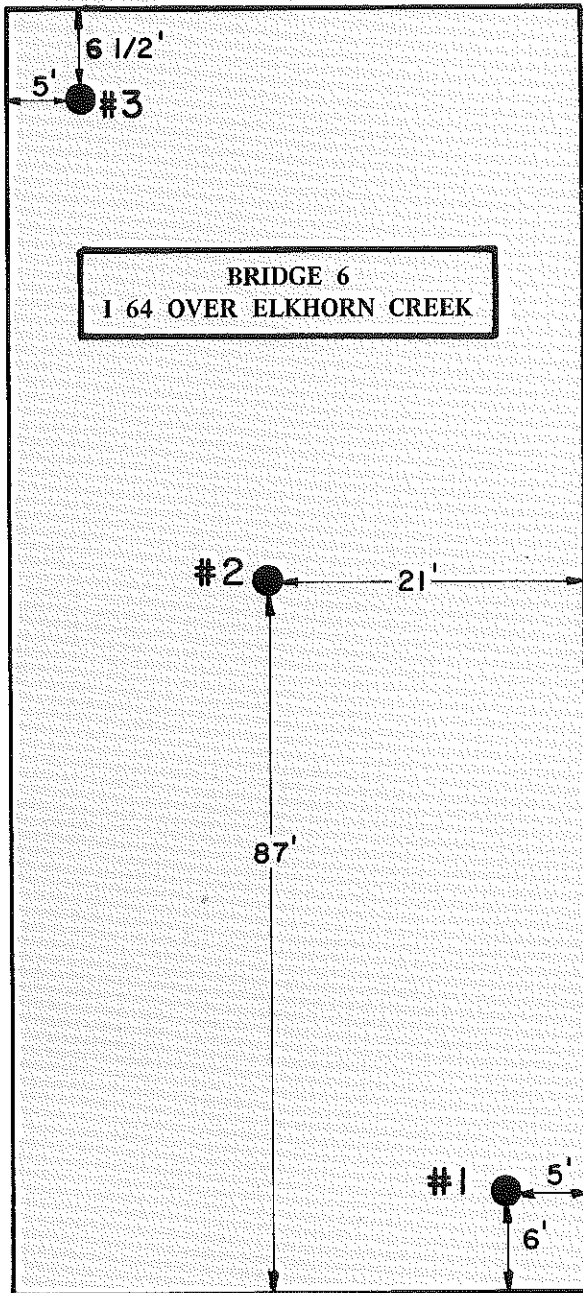

BRIDGE 6
I 64 OVER ELKHORN CREEK

↑ EASTBOUND

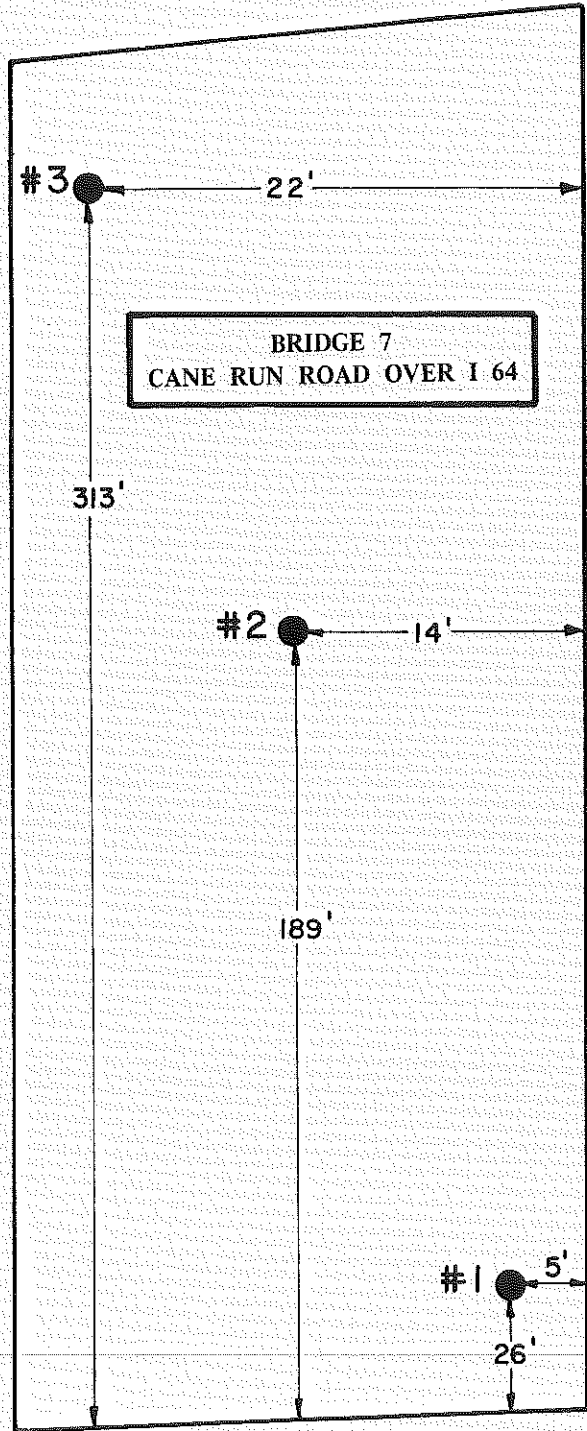

BRIDGE 7
CANE RUN ROAD OVER I 64

↑ SOUTHBOUND

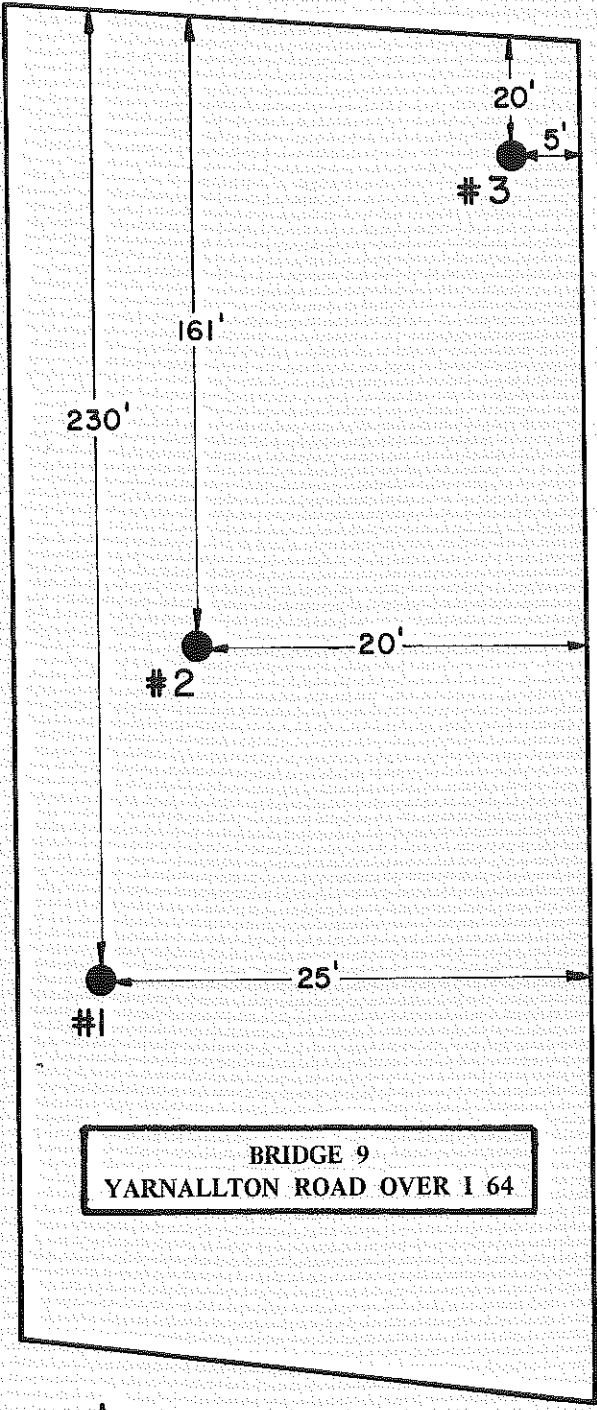
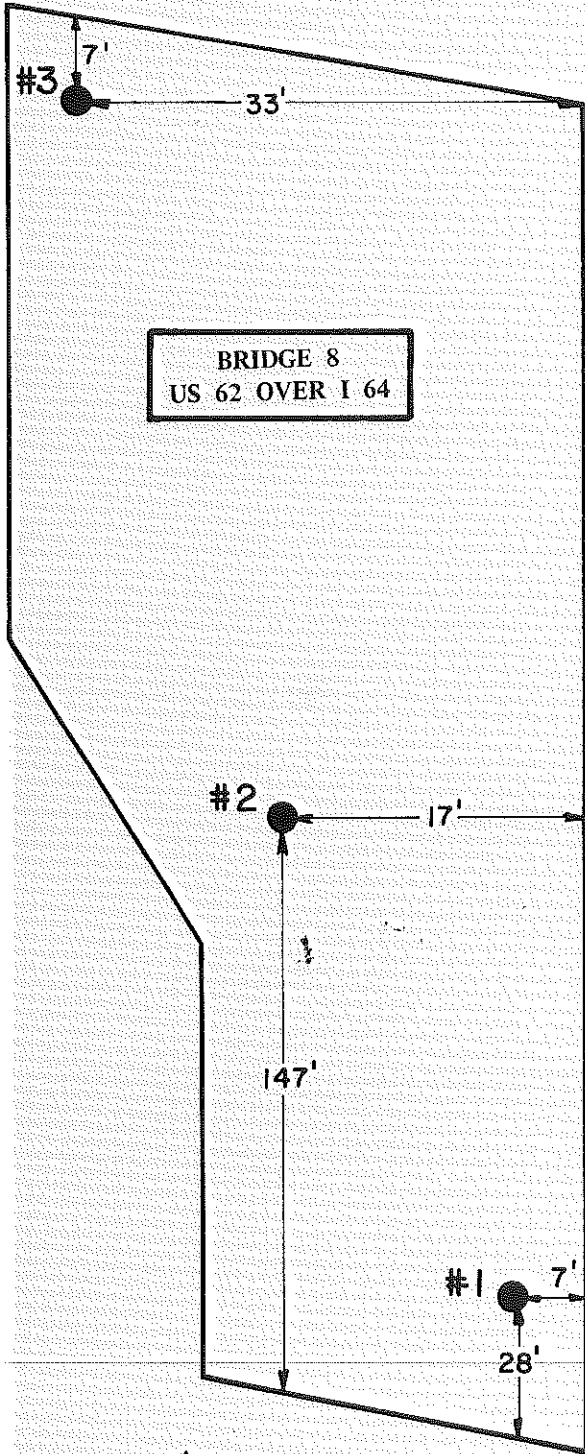

NORTHBOUND

SOUTHBOUND