

Research Report
UKTRP-86-17

PERFORMANCE MONITORING OF A HIGHWAY TIEBACK
WALL (I 71, Carroll County, KY 227,
Corrective Landslide Measure)

by

Bobby W. Meade
Transportation Research Investigator

David L. Allen
Chief Transportation Research Engineer

and

T. C. Hopkins
Chief Transportation Research Engineer

July 1986

1. Report No. UKTRP-86-17	2. Government Accession No.	3. Recipient's Catalog No.	
4. Title and Subtitle Performance Monitoring of a Highway Tieback Wall (I 71, Carroll County, KY 227, Corrective Landslide Measure)		5. Report Date July 23, 1986	
		6. Performing Organization Code	
7. Author(s) Bobby W. Meade, David L. Allen, Tommy C. Hopkins		8. Performing Organization Report No. UKTRP-86-17	
9. Performing Organization Name and Address Kentucky Transportation Research Program College of Engineering University of Kentucky Lexington, KY 40506-0043		10. Work Unit No. (TRAIS)	
		11. Contract or Grant No. DTFH71-84-931-KY-02	
12. Sponsoring Agency Name and Address Kentucky Transportation Cabinet State Office Building Frankfort, KY 40622		13. Type of Report and Period Covered	
		14. Sponsoring Agency Code	
15. Supplementary Notes Prepared in cooperation with the US Department of Transportation, Federal Highway Administration. Study title: Federal-Aid Research Task No. 10 -- Performance Monitoring of a Highway Tieback Wall			
16. Abstract <p>A tieback wall was used to control an earth slide on KY 227 in Carroll County. Herein is contained a description of the wall construction and problems encountered during construction. Also included are descriptions of materials used and wall components.</p> <p>The short-term wall performance indicates the tieback wall has controlled the earth slide and, to date, is a satisfactory solution. Long-term monitoring of the tieback wall will continue.</p>			
17. Key Words Tieback Wall Stability Slide		18. Distribution Statement Unlimited with permission of the Kentucky Transportation Cabinet	
19. Security Classif. (of this report) Unclassified	20. Security Classif. (of this page) Unclassified	21. No. of Pages 97	22. Price

Research Report
UKTRP-86-17

PERFORMANCE MONITORING OF A HIGHWAY TIEBACK WALL
(I 71, Carroll County, KY 227, Corrective
Landslide Measure)

by

Bobby W. Meade
Research Investigator

David L. Allen
Chief Research Engineer

and

Tommy C. Hopkins
Chief Research Engineer

Kentucky Transportation Research Program
College of Engineering
University of Kentucky
Lexington, Kentucky

in cooperation with
Kentucky Transportation Cabinet
Commonwealth of Kentucky

and

Federal Highway Administration
U.S. Department of Transportation

The contents of this report reflect the views of the authors who are responsible for the facts and the accuracy of the data presented herein. The contents do not necessarily reflect the official views or policies of the Kentucky Transportation Cabinet, the Federal Highway Administration, nor the University of Kentucky. This report does not constitute a standard, specification, or regulation.

July 1986

PROBLEM STATEMENT

Over the past several years, an unstable cut-and-fill embankment on KY 227 (Carrollton-Worthville Road) in Carroll County had been failing. The problem area is located approximately eight miles southeast of Carrollton between Stations 234+25 and 244+25. This slide caused numerous maintenance problems for the roadway, which was frequently overlaid, and for the nearby railroad track, which had to be periodically realigned. As shown in Figure 1, prior slippage had lowered the shoulder several feet. A view from approximately the same location is shown in Figure 1A. A vicinity map of the slide area, is shown in Figure 2. Figure 2 presents a vicinity map of the slide area.

GEOLOGY

This site lies in the northern part of the Outer Bluegrass topographic region of Kentucky. It consists of predominately interbedded shales and limestones of the middle and upper series of Ordovician age. Glacial deposits and recent alluvium are present in the river flood plain.

The primary geologic formation involved in the slide is the Kope Formation. In this area, the Kope Formation is a medium gray shale interbedded with a medium gray limestone. Limestone generally comprises about 15 to 30 percent of the formation and usually occurs in even to slightly irregular beds about 12 inches thick. Thin beds of laminated calcareous siltstones are also occasionally found.

SUBSURFACE CONDITIONS PRIOR TO CORRECTIVE ACTION

The Division of Materials of the Kentucky Department of Highways conducted a geotechnical exploration of the site with borings located at

Station 236+00 -- 45 feet right of centerline,
Station 236+00 -- 45 feet left of centerline,
Station 236+50 -- 50 feet right of centerline, and
Station 237+00 -- 45 feet left of centerline.

Laboratory tests were conducted on samples obtained at Station 236+50 -- 50 feet right of centerline. Test results indicated the material to be an A-7-6 (19) soil according to the AASHTO classification system and a CL according to the Unified classification system. The natural moisture content was 17 percent at a depth of 10.0 to 11.5 feet. At a depth of 20.0 to 21.5 feet, the AASHTO classification was A-6 (18) and the Unified classification was CL. The natural moisture content was 16 percent.

Slope inclinometers number 3 and 2 were installed at Station 236+50 (50 feet right of centerline) and at Station 236+00 (45 feet right of centerline), respectively. Both slope inclinometers indicated deflection rates of 0.2 inch per month. The sliding plane was at elevation 466.0 feet, which was 25 feet below the shoulder.

The two borings left of centerline were used as observation wells. The average water-table depth was 2 feet at Station 236+00 (well 1A) and 4 feet at Station 237+00 (well 1B). A plan view of the site, including structures natural features, and instrumentation previously discussed, is shown in Figure 3.

The in situ soil strength parameters were estimated by iteration. The soil unit weight and cohesion were held constant while the angle of internal friction was varied to arrive at a safety factor of 1.0. The results are

$$\begin{aligned}w &= 128 \text{ pcf,} \\c &= 0 \text{ psf,} \\\phi &= 18 \text{ degrees.}\end{aligned}$$

The cross section used in the existing conditions analysis is shown in Figure 4.

REMEDIAL OPTIONS

Several remedial procedures were considered, with an increase of at least 30 percent in the safety factor as the critical criterion. Realignment of KY 227 further into the hillside was readily eliminated as impractical. That option would involve disturbing an already marginally stable hillside and require excavation, repaving, and right-of-way changes for at least one-half mile. Flattening the slope also was eliminated because it would adversely affect the railroad.

Three other remedial procedures were considered. They were horizontal drains, rail piles, and a tied-back control wall. The horizontal drain option would result in a safety factor of 1.1 to 1.2 at an approximate cost of \$62,000. This did not meet the criterion of a 30-percent increase of the safety factor. Rail piles perform best at depths to bedded material of less than 15 to 20 feet. The soil depths at this site exceed 20 feet. The tied-back control wall was chosen as the best alternative. A contract for construction of the wall was awarded on December 18, 1983.

STUDY PROPOSAL

The use of tieback walls to control landslide problems is somewhat limited. For that reason, a study was initiated with the objectives of

- (1) documenting construction procedures and obtaining short-term and long-term experimental data on tieback wall performance,
- (2) analyzing field behavior using instrumentation installed on and near the wall, and
- (3) making recommendations as to the effectiveness and future use of tieback walls constructed with treated wood lagging for correcting highway embankment sliding.

Monitoring of the wall is to continue for a period of five years. Data and observations subsequent to this report will be presented annually in the form of a memorandum.

WALL DESIGN, LAYOUT, AND CONSTRUCTION

The tieback wall was designed and constructed by the Schnabel Foundation Company in compliance with Department of Highways Special Notes (Appendix A). Design personnel were supplied a design restraint force of 33,000 pounds per linear foot of wall where the sliding plane was 25 feet below the top of the wall. A safety factor of 1.5 was assumed. This translates to a normalized uniform loading (p) of:

$$p = 0.0528 \text{ kip/foot} \times h,$$

where h is the height of the wall in feet. The wall was constructed using a system of steel H-piles, pressure-treated wood lagging, and

corrosion-protected tiebacks. A typical wall section is shown in Figure 6. The assumption of a safety factor of 1.5 and testing up to 133 percent of design load (to be discussed in the TIEBACK TESTING section) resulted in test loads of 200 percent of expected loading. This conservative approach was probably the result of a lack of experience with this type structure. Design calculations presented by Schnabel are contained in Appendix B.

The tied-back wall, as designed, extended from Station 234+25 to Station 244+25. At Station 234+25, the wall was 76 feet right of centerline. The wall gradually approaches centerline, and at Station 235+50 it is 70 feet right. At that point, the wall bends toward the centerline, making it only 40 feet right at Station 236+00. From Station 236+00 to the ending station, the wall is approximately 43 feet right of the centerline. The height of the wall is approximately 15 feet above finished grade. Total cost of the wall and associated efforts was \$483,000. A plan view and front view of the wall are shown in Figure 7. Excluding the cost of excavation, cost of the wall was \$31.25 per square foot of exposed wall.

GENERAL CONSTRUCTION

A total of 126 soldier piles were driven on approximately 8-foot centers. Of these, 90 were 10 x 42 H-piles and the remaining 36 were 12 x 53 H-piles. Driving points were specified for penetration of a boulder zone and to insure proper seating. Piles were driven to a resistance of 100 tons or refusal. Refusal was considered to be less than 0.8 inch penetration in 10 hammer blows.

After the piling was driven, the existing embankment was excavated below the elevation of the highest tiebacks -- Figure 8. The piling was then cleaned and stud bolts were welded to the pile flanges. The stud bolts were later used to attach 4-inch by 8-inch treated wood lagging to the pile face. Exposed surfaces of the piling and bolts were protected by an application of "Tapecoat TC Mastic" -- Figure 9.

The lagging was treated southern yellow pine timbers attached to the piling by threaded studs, steel plates, and nuts. There were approximately 2-inch gaps between the lagging through which the threaded studs protruded. The gap was spanned by metal plates and fastened in place with nuts.

Treatment of the lagging consisted of a combination vacuum and pressure. The timber was subjected to a vacuum approaching 27 inches of mercury for 30 minutes. The treatment solution was then pressure injected (140 psi) into the wood for 50 to 60 minutes. The solution consisted of 44.01 percent chromic oxide, 19.27 percent cupric oxide and 36.72 percent arsenic pentoxide. A 3.27 percent concentrate solution was used.

Before the lagging was installed, a drainage pathway was placed between the wall and embankment. The pathway consisted of a layer of AMOCO 4553 fabric placed against the soil embankment and a layer of TENSAR "PWI" grid against the lagging -- Figures 6 and 10. At the bottom of the wall, the pathway ended in a trough made of a cut section of corrugated plastic pipe. A collector system of 8-inch pipe was placed in the trough with outlet lines spaced at approximately 24 feet. The cavity behind the lagging was backfilled with the material previously excavated. The backfill was completed prior to testing, but in many cases failed to support the piling sufficiently during loading. Where the piling deflected too much the soil was removed and replaced with weak concrete. After placement of the drainage pathway, the lagging was installed beginning at the top of the piling.

TIEBACKS

When the wall had been constructed down to the elevation of a tieback, a hole was drilled into rock and a steel tendon grouted in place. Each tieback was tested when the grout had reached sufficient strength. If the tieback tested acceptably, it was eventually locked off at 75 percent of design load. This lock-off load was chosen to permit some relaxation and movement of the retained embankment. The grout mixture contained Type III portland cement.

Two tiebacks were placed in a bay midway between piles. The tiebacks were stacked vertically with alternating bays tied back. Toward the ends of the wall where the depth to rock decreased, one tieback on alternating bays was used. For a distance of approximately 110 feet (Station 234+80 to Station 235+90), four tiebacks on alternating bays were used. Where tiebacks failed, additional tiebacks were placed until tests indicated design restraint was achieved.

In Figure 11, completed sections of the wall are shown. Double caps where supplementary tiebacks had to be installed may be noted in the foreground. At the top of the wall, a fence was erected to protect unwary pedestrians.

A soldier beam and tieback schedule is shown in Table 1, page 43.

Tiebacks are high-strength, in this case, multi-stranded, steel tendons anchored in rock at one end, stressed, and then anchored to the wall at the other end. The fixed anchorage or bond length is accomplished by drilling a hole (minimum of 10 feet) into competent rock and grouting the tendon into place. The hole must be clear of deleterious material and centralizers and spacers located so there is a minimum of 1/2 inch grout cover on the tendon. The bond length is calculated by the equation:

$$L_b = p / (3.1416) (d) (t_w)$$

in which L_b = bond length (not less than 10 feet in solid rock)(feet),

p = design Load for tieback (pounds),

d = diameter of the drill hole (inches), and

t_w = bond stress at the interface between rock and grout (psi).

The unbonded length(L_f) is the portion of the tieback free to elongate elastically during stressing. This length is a minimum of 15 feet and is sufficiently long to insure that the bond length is formed in sound competent rock. Tiebacks were installed at angles varying from 10 degrees to 30 degrees from horizontal. A typical tieback cross section is shown in Figure 12.

INSTRUMENTATION

Several types of instrumentation were installed to monitor performance of the wall. Types of instrumentation consisted of equipment to stress and test a tieback, slope inclinometers, ground-water observation wells, tiltmeters, permanent load cells, and earth pressure meters. Optical surveys of the wall also were conducted.

Equipment for stressing and testing the tiebacks consisted of a hydraulic jack for supplying load, pressure gages for monitoring stress, dial gages for monitoring movement, and accessory equipment such as jack stands, gage supports, etc. Stressing and testing of the tiebacks will be discussed in the "TIEBACK TESTING" section.

Four permanent load cells were installed near Stations 235+90 (Tieback 21) and 237+64 (Tiebacks 43-44). At each location, two load cells were installed. One cell was on the upper or first tier tieback and one was on the lower or second tier tieback. These cells were used to monitor the short- and long-term stresses on the tendons supporting the wall.

Earth pressure meters were installed between the wall and earthen embankment. These meters are used to monitor pressure on the wall as opposed to the permanent load cells that monitor stress on the tendon supporting the wall. Nine meters were installed. Five were located in the center of the bay or midway between Piles 46 and 47, Station 237+88. These five meters were numbered 1540, 1447, 1541, 1449, and 1659, respectively, from the top of the wall. The other four meters were located as close as possible to Pile 47. They were numbered from the top 1444, 1615, 1542, and 1614, respectively. The top meter on each row was placed approximately two feet below the top of the wall and the remaining meters were spaced at 2.0 to 2.5 foot intervals down the wall. In Figure 13, the top eight meters may be seen with the top two located between the third and fourth lagging from the top of the wall.

As lagging installation proceeded down the wall, pressure meters were installed at the desired locations. The meters were loosely attached to the back side of the lagging with the monitoring cables exiting the open face of the wall. The cables were enclosed in plastic conduit and brought to a common monitoring point. After the meters were in place, the cavity behind the wall was backfilled with the previously excavated material and compacted with gasoline operated hand compactors.

A total of seven slope inclinometers were installed to monitor horizontal earth movement. Five inclinometers were installed behind the wall near Stations 236+00, 237+00, 238+00, 239+00, and 240+00. Location of the inclinometers ranged from 4 to 10 feet behind the wall. Two

inclinometers were installed approximately 85 feet right of centerline near Stations 236+00 and 237+00.

Three ground-water observation wells were installed approximately 35 feet right of centerline near Stations 237+50, 238+50, and 239+50. One observation well was installed approximately 30 feet left of centerline at Station 237+00. These wells, in conjunction with the slope inclinometer holes and observation wells installed during the earlier geotechnical investigation, permitted monitoring of the water table at the site.

Tiltmeter plates were installed on the wall near Stations 236+00, 237+00 and 238+50. These plates were installed on the wood lagging. Due to irregularities of the lagging and fluctuations of the characteristics of the wood related to changing moisture conditions, data obtained from these meters were not consistent. Location of instrumentation used to monitor the structure during and after construction of the wall is shown in Figure 14.

TIEBACK TESTING

Each tieback was load tested by one of three types of tests. The three test types were creep tests, performance tests and proof tests. Creep tests and performance tests both essentially incrementally loaded and unloaded the tendon to 133 percent of the design load and monitored tendon elongation or movement. These two tests were conducted on a limited number of tiebacks and required a substantial amount of time.

All tiebacks not tested by either creep or performance tests were proof tested. This test is of relatively short duration and consists of loading the tendon to 120 percent of the design load and maintaining that load five minutes. If creep movement during the five minutes is less than 0.03 inch and movement patterns are similar to adjacent tests the tieback is acceptable. If these criteria are not met, but the creep rate over a longer period of time was determined to be less than 0.08 inch per logarithmic cycle of time, the tieback was accepted.

Four tiebacks were creep tested. This test required loading and unloading the tendon through gradually increasing load and time

increments until 133 percent of the design load was reached. This load was maintained and movement observed for 300 minutes. An acceptable tieback performance was a creep rate less than 0.08 inch per logarithmic cycle of time.

Five selected tiebacks and 5 percent of all remaining tiebacks were performance tested. This test involved loading and unloading the tendon through gradually increasing load and time increments until 133 percent of the design load was reached. This load was maintained for 10 minutes after which time the test was discontinued if movement was less than 0.04 inch. If movement exceeded 0.04 inch the load was maintained for 60 minutes and the movement recorded. Acceptable performance for these tests was

- (1) measured elastic movement exceeding 80 percent of the theoretical elongation of the unbonded tendon
- and
- (2) creep movement between 1 and 10 minutes less than 0.04 inches.

Tiebacks failing criterion number 2 were accepted if the creep rate over 60 minutes of maximum loading was less than 0.08 inches per logarithm cycle of time. Schedules for the three tests are found in Appendix A.

Equipment for testing the tiebacks may be seen in Figure 15. A hydraulic jack is affixed to the exposed tendons and load is applied. Resultant stress is monitored by gages not shown in the figure and the deflection is monitored with the dial gage mounted on the tripod.

TEST DATA AND RESULTS

LABORATORY DATA

Laboratory tests were conducted on samples obtained at the slope inclinometer borings. Moisture content of samples tested ranged from 12.6 to 23.5 percent and averaged 17.7 percent. Specific gravity ranged from 2.67 to 2.81 with an average of 2.70. The material classified as A-6 or A-7-6 by the AASHTO system or CL by the Unified system. Results of index tests are contained in Table 2.

A series of consolidated-undrained triaxial tests was performed. Results of these tests indicate an internal friction angle of 37 degrees and a cohesion of 0.

LATERAL MOVEMENTS

Slope inclinometers are identified as numbers 1, 4, 6, 8, 10, 11, and 12. The locations of Inclinometers 1 through 10 are behind the wall, approximately 40 feet right of the centerline, in order of ascending Stations 236+00, 237+00, 238+00, 239+00, and 240+00, respectively. Inclinometers 11 and 12 are located approximately 85 feet right of the centerline at Stations 236+00 and 237+00, respectively. Inclinometers 1, 6, 8, and 10 were installed in the first week of March 1984, which was before excavation for wall construction began. Inclinometer 4 was installed May 5, 1984, after the wall was essentially complete. Inclinometers 11 and 12 were installed June 18 and 11, respectively.

Data obtained at Inclinometers 1 through 10 indicate little movement at depths greater than 4 or 5 feet. The exception to this is Inclinometer 1. This is approximately the location of monitoring instrumentation in place prior to corrective action. The sliding plane then was located approximately 25 feet below the surface. Data from Inclinometer 1 indicate a displacement of 0.5 inch 47 days after installation of the inclinometer. This movement took place primarily along the existing sliding plane. Records indicate that final tiebacks near that location were stressed and locked off on May 11, 1984. After that date, little movement has been observed at that location -- Figure 16.

All inclinometers near the wall indicate the greatest movement within 4 to 5 feet of the surface -- Figures 16 through 20. This is probably due to sloughing of the embankment after the material below the piling was excavated. The magnitude of this movement ranged from 0.5 inch to 1.5 inches. In Figures 21 through 23, movements at selected depths are plotted versus time and the dates of tieback lock off are noted. The top of the embankment was pulled back toward its original position when the tiebacks were stressed. In Figure 21, the movement toward the original position is illustrated for each inclinometer at

approximately 125 to 150 days. This coincides with the locking off of tiebacks. At depths greater than 5 feet, embankment movement (with the exception of Inclinator 1) was less than 0.3 inch.

Inclinometers 11 and 12 indicate maximum movements of 0.2 and 0.8 inch, respectively. Movement at Inclinator 11 is of such small magnitude that it is probably insignificant (Figure 24). It probably is erratic because it is approaching the limit of resolution of the instrument. At Inclinator 12, movement is occurring throughout the entire depth of soil. As of March 1986 0.8 inch movement had occurred, but approximately 0.5 inch movement occurred from February to November of 1985. Figure 25 shows movement is continuing at this location, but the rate has decreased.

As noted earlier, instrumentation intended to monitor tilt of the wall did not function properly. However, optical surveys were conducted to establish the initial position of the wall. Elevation of the top of the wall and plumb of the vertical face were established. No measurable changes have been observed.

PRESSURE DATA

Earth pressure on the wall and retaining stress of the tiebacks were monitored with earth pressure meters behind the wall and permanent load cells on the tiebacks. The earth pressure meters used were high range meters (200 psi). Sensitivity of these meters was such that, except during testing and tieback lock off, pressure on the wall was too low to be monitored accurately. Initial readings were obtained prior to the backfilling operation. These readings were used as zero readings and subsequent readings were compared to them.

During testing and lock off, pressure on the wall ranged from 0.0 to approximately 10.0 psi at some locations. Pressure data obtained from earth pressure meters are shown in Figures 26 and 27. As seen in these figures, long-term pressure on the wall appears to be insignificant. The apparent negative pressure readings are a result of the low sensitivity of the 200 psi meters at the low existing pressure conditions.

Permanent load cells were installed on Tiebacks 21 and 43-44. At both locations, the higher (first tier) and lower (second tier) tiebacks

were instrumented. Tieback 21 is approximately located at Station 235+90 in a bay where four tiebacks were used. Tieback 43-44 is approximately located at Station 237+64. At this location, only two tiebacks per bay were used.

Lock-off loads on the tendons ranged from 68.8 kips to 132.0 kips. Loads on all tendons decreased with time and eventually ranged from 53.1 to 83.0 kips. Load cell data are plotted versus time in Figure 28.

WATER TABLE

Water-table elevations were monitored with observation wells located at Stations 236+00 (45 feet left), 237+00 (30 feet left), 237+50, and 238+50 and 239+50 (27 to 35 feet right)(see Figure 14). The water table fluctuated during construction of the wall, but gradually rose after the wall was complete. Water-table depths are shown in Figure 29, with completion of the wall occurring at approximately 200 days.

DURABILITY

Durability of the structure, primarily the exposed wood lagging and metal surfaces, was a major concern. Visual inspections and soundness checks indicate these wall components have not noticeably deteriorated during the first two years.

PROBLEMS

The most common problem associated with this project involved the inability of tiebacks to withstand test loading. Some of the reasons for tieback failure were the following:

1. "Slick holes" resulting from drilling an anchorage shaft in the presence of water. Native rock at this site (Kope Formation shale) weathers rapidly in the presence of water. Bond between the grout and rock would be reduced in this case, thus permitting slipping of the tieback.

2. Broken strands of the tendons accounted for several tieback failures. Of 121 tiebacks designed for the project, 25 failed and were replaced or supplemented with additional tiebacks.

Several tieback tests were discontinued due to excessive movement of the wall. In some cases, the piling deflected more than 4 inches at only 50 percent of design load or approximately 75 percent of the required resisting force. The solution to this problem was to excavate behind the piles and backfill with a weak concrete mix.

Temporary delays were caused by failure of the welds on the threaded studs affixing the lagging to the piling and recalibration of the jack used to load the tiebacks.

CONCLUSIONS

The tied-back wall, to the present, has performed well. Lock-off loads on the tiebacks were 75 percent of design load. Present loads are considerably less than lock-off. Pressure on the lagging appears to be insignificant. Using the previously noted loading ($p = 0.0528$ kip/foot \times h), the wall at the pressure meter location was designed to support 7.33 pounds per square inch. Initial pressure on the lagging was about 50 percent of the design restraint with two meters briefly exceeding that (Figures 25 and 26). This has since dropped to nearly zero at all metered locations. Pressure meters having better resolution would have been desirable for this application. However, the resolution of the meters is such that any significant pressures would have been measured.

Earth movement behind the wall has been controlled. The sliding failure existing prior to wall construction appears to have stabilized. In the vicinity of Station 236+00, movement along the sliding plane was observed until the tiebacks were stressed. Since that time, movement has been minimal. Below the wall at Slope Incliner 12 (85 feet right of Station 237+00), approximately 0.8 inch of lateral movement, Figure 25, was observed from October 10, 1984, to November 18, 1985. Movement is still occurring, but its rate has decreased. Surface slumping, due to excavation, was stabilized when the tiebacks were stressed.

Since its completion, the wall has not moved or tilted. Optical surveys of the walls initial and more recent positions verify its stability.

Perhaps the reduction of tieback stress and earth pressures may be explained by a combination of soil cohesion and relaxation of the wall components. Before the tiebacks were stressed, the embankment continued to slide and to slump where the soil had been excavated. When the tiebacks were stressed, those movements ceased.

After stressing of the tiebacks the tieback tendons, piling, and lagging began to relax. This reduced the pressure on the wall components but restrained the embankment sufficiently to prevent it from moving along the sliding plane again. The cohesive component of shear strength (cementation) of the embankment may have prevented it from relaxing to the point of maintaining or increasing the original pressure on the wall.

While the retained embankment is apparently stabilized, the material below or in front of the wall may not be stabilized. The driving force on the embankment below the wall has been reduced, but movement continues. The rate of movement has decreased from 0.05 inch per month to 0.009 inch per month, but monitoring will continue. If embankment movement should continue, alignment of the railroad and possibly the stability of the retained embankment could be adversely affected. The movement below the wall, Figure 25, apparently justifies the assumption, Figure 5, of no soil resistance in front of the wall.

In general, the methods and materials used in construction of the wall appear acceptable. Problems, such as unacceptable pile deflection during testing, jack recalibration, and poor stud bolt welding, caused relatively short delays. More significant delays resulted from "slick holes" and broken tendon strands. This led to placement of additional tiebacks. Overall, the construction progressed satisfactorily.

It is anticipated that future design of similar structures will be less conservative. One tieback wall has been constructed in Kentucky since the completion of the study structure. The second structure was designed with a safety factor of 1.0 and tested to 133 percent of design load.

TABLE 1. SOLDIER BEAM AND TIEBACK SCHEDULE

SOLDIER BEAM NUMBER	SOLDIER BEAM SIZE	SOLDIER BEAM GRADE	H1* OR TIEBACK		DESIGN LOAD (KIPS)	L _f *** (FT)	L _b (MIN.)**** (FT)	TENDON STRANDS			
			H2** (FT)	ANGLE (DEGREE)				NUMBER	SIZE (IN)	WALE SIZE	WALE GRADE
TIEBACK TIER #1											
1-2	HP10x42	A36	-	-	-	-	-	-	-	-	-
3-4	HP10x42	A36	5'	30	98	40'	10'	3	0.6	2C15x33.9	V50
5-6	HP10x42	A36	6.75'	28	174.5	40'	15'	5	0.6	2MC18x51.9	V50
7-8	HP10x42	A36	4'	30	151	40	15'	5	0.6	2MC18x42.7	V50
9-22	HP12x53	A36	5'	30	156	40	15'	5	0.6	2C15x33.9	V50
23-72	HP10x42	A36	4'	20	175.9	30	15'	5	0.6	2MC18x51.9	V50
73-90	HP10x42	A36	4'	20	139	20	15'	4	0.6	2MC18x42.7	V50
91-98	HP10x42	A36	4'	20	116	20	15'	4	0.6	2C15x40	V50
99-120	HP12x53	A36	6.75'	20	164	15	15'	5	0.6	2MC18x51.9	V50
121-124	HP10x42	A36	5'	20	90	15	10'	3	0.6	2C15x33.9	V50
125-126	HP10x42	A36	-	-	-	-	-	-	-	-	-
TIEBACK TIER #2											
1-2	HP10x42	A36	-	-	-	-	-	-	-	-	-
3-4	HP10x42	A36	-	-	-	-	-	-	-	-	-
5-6	HP10x42	A36	-	-	-	-	-	-	-	-	-
7-8	HP10x42	A36	6.5'	30	98	30	10'	3	0.6	2C15x33.9	V50
9-22	HP12x53	A36	10'	30	122	30	15'	4	0.6	2C12x25	V50
23-72	HP10x42	A36	7.5'	20	138.3	20	15'	4	0.6	2MC18x42.7	V50
73-90	HP10x42	A36	6.5'	20	90.5	15	10'	3	0.6	2MC15x33.9	V50
91-98	HP10x42	A36	5.5'	20	57	15	10'	2	0.6	2C12x25	V50
99-120	HP12x53	A36	-	-	-	-	-	-	-	-	-
121-124	HP10x42	A36	-	-	-	-	-	-	-	-	-
125-126	HP10x42	A36	-	-	-	-	-	-	-	-	-

* H1 is the distance from the top of the wall to the top or tier #1 tieback.
 ** H2 is the distance from the top or tier #1 tieback to the lower or tier #2 tieback.
 *** L_f is the unbonded length of tendon.
 **** L_b is the bonded or fixed length of tendon.

TABLE 2. SUMMARY OF LABORATORY INDEX TESTS

BORING	SAMPLE	DEPTH (FEET)	MOISTURE CONTENT(%)		ATTERBURG LIMITS				SPECIFIC GRAVITY	CLASSIFICATION		CIU TESTS	
			NAT	HYG	LL	PL	PI	LI		AASHTO	UNIFIED	ϕ (deg)	c (psi)
HOLE-1 STATION 236+00	1	2 - 3	13.5										
	2	7 - 9	16.7										
	3	12 - 14	16.9										
	4	17 - 18	12.7	2.38	37.8	21.9	15.9	-0.58	2.68	A - 6(15)	CL	37.6	0.0
	6	22 - 23	18.4										
	7	27	12.6										
HOLE-4 STATION 237+00	1	2 - 3	18.1		32.3	20.7	11.6	-0.22	2.81				
HOLE-6 STATION 238+00	1	2 - 4	22.3										
	3	12 - 14	19.7	2.4	39.6	22.1	17.5	-0.14	2.67	A - 6(18)	CL		
	4				34.0	20.5	13.5						
HOLE-8 STATION 239+00	1	2 - 4	23.5										
	2	7 - 8.5	18.0	2.46	42.0	26.4	15.6	-0.54	2.68	A-7-6(22)	CL		
	3	12 - 14	17.0										
	4	17 - 18	19.2										
HOLE-10 STATION 240+00	1	2 - 3	18.3										
	2	7 - 8	17.0	2.24	41.5	18.3	23.2	-0.06	2.68	A-7-6(18)	CL		
	4	17 - 18	18.7										

APPENDIX A
SPECIAL NOTE
FOR
PERMANENT ANCHORED WALL
CORRECTION OF SLIDE #2
KY 227, CARROLL CO., KY

LIST OF PREQUALIFICATION REQUIREMENTS

1. The contractor shall complete or revise, depending on the company's current prequalification status with the Transportation Cabinet, a prequalification application. This application should include all relevant equipment and experience information concerning permanently anchored walls. This application must be submitted to the Transportation Cabinet for review.
 - A. The contractor shall be experienced in the design and construction of permanently anchored walls.
 - B. The contractor's staff shall include at least one registered professional engineer with at least five (5) years of experience in the design of permanently anchored walls.
 - C. The contractor's staff shall include at least one registered professional engineer with at least five (5) years of supervising experience in the construction of permanently anchored walls.
 - D. The contractor's staff shall include drilling operators and foremen with a minimum of one (1) year's experience installing permanently anchored walls.
 - E. The contractor shall list any active or completed projects that are similar in concept and scope to the proposed wall.
2. The contractor shall be responsible for preparing and submitting a final design proposal describing the permanently anchored wall system he/she intends to provide for the Carroll County, KY 227 project. This proposal should be based on the accepted "Design Criteria" and specific project information such as soil conditions, location, etc. The final design proposal shall include:
 - A. Description of the tie-back installation (including drilling, grouting and stressing information).
 - B. Estimated tie-back capacity.
 - C. Tendon type and capacity.
 - D. Anchorage type.

- E. Minimum bonded lengths, minimum unbonded lengths, total tie-back lengths-angles of installation and locations.
 - F. H-Pile sizes and spacings, tie-back sizes and spacings, wale sizes and spacing. Protection system for piles, wales and other exposed hardware.
 - G. Wall drainage details.
 - H. Lagging type, size and grade. Description of pressure treatment of lagging. Hardware details. Erection sequence.
 - I. Tie-back corrosion protection details (shop drawings required).
 - J. Exceptions to the specifications and reasons for the exceptions.
 - K. Detailed plans for proof, creep performance, and liftoff testing of tie-backs showing loading and measuring devices to be used and locations and procedures to be followed.
 - L. A copy of your design calculations, notes, details, drawings, etc. sufficient for our review and approval of your proposal.
3. The contractor shall submit his completed design package to this office no later than August 31, 1983. Your pre-qualification forms and requests for changes or exceptions affecting the design of the "Permanent Anchored Wall" must be received in this office no later than August 22, 1983. Approval of your request will be by return mail. Request affecting the construction or bidding must be received by August 31, 1983. Any approvals for changes or exception will only be received from this office.
4. Questions concerning geotechnical information and load diagrams should be directed to Henry Mathis, Division of Materials, Geotechnical Section, phone (502) 564-3160. Questions concerning materials should be directed to John McChord, Director, Division of Materials, phone (502) 564-3160. General questions should be directed to Tom Layman, Director, Division of Bridges, phone (502) 564-4560. Questions concerning pre-qualification forms should be directed to Lloyd Shannon, Branch Manager, Office for Contract Management, phone (502) 564-3500.

5. We will review your submittal and return it to you by September 15, 1983. You will have until September 23, 1983 to resolve any questions as a result of our review. We must have copies of your plans, acceptable for reproduction, by September 23, 1983. FHWA will receive a copy of entire contract plans including your plans and any other approved plans from other specialty contractors. On October 14, 1983 the Department will notify contractors, on their approved list, about the contract which includes this wall. This project is scheduled for a November 11, 1983 letting.

TABLE OF CONTENTS

<u>TITLE</u>	<u>PAGE</u>
INTRODUCTION	1
SCOPE OF WORK	1
GENERAL	1
DESIGN CRITERIA	4
ROCK TIEBACKS	6
MATERIALS	10
TESTING	15
CUTTING OF TENDONS	17
REDESIGN	17
INSTRUMENTATION	17
MONITORING	18
RECORDS	18
MEASUREMENT AND PAYMENT	19
FIGURE 1 - LOAD CASE 1	21
FIGURE 2 - LOAD CASE 2	22
FIGURE 3 - INSULATED SIMPLE CORROSION TIEBACK	23
FIGURE 4 - CREEP TEST SCHEDULE	24
FIGURE 5 - PERFORMANCE TEST SCHEDULE	25
FIGURE 6 - PROOF TEST SCHEDULE	26
APPENDIX - GEOTECHNICAL MEMORANDA	27

SPECIAL NOTE FOR PERMANENT ANCHORED WALL
CORRECTION OF SLIDE #2
KY 227, CARROLL COUNTY, KENTUCKY

INTRODUCTION

The work covered under this special note is for a permanent anchored wall in Carroll County, Kentucky. This wall will be constructed right of KY 227 from Stations 234+80 to 240+00. This wall will be used to control a landslide referred to as Slide #2 on the Roadway Plans and in the Geotechnical memoranda.

SCOPE OF WORK

The work covered under this special note includes furnishing of all materials, labor, tools, equipment, and other incidental items required for designing, detailing, constructing, testing, and monitoring a permanent anchored wall as described herein.

This special note also describes the materials, labor, and equipment required for the installation testing and monitoring of the permanent anchored wall required for this project.

The term "Anchored Wall" shall include but not be limited to the following items: Tiebacks, Soldier Piles, Wales, Lagging, and Drainage. The wall will be constructed using a system of steel H-Piles, pressure treated wood lagging and corrosion protected tiebacks.

GENERAL

A. Tieback Capacity

The Contractor shall be responsible for obtaining the desired tieback capacity in accordance with the testing section of this specification.

This special note contains the pressure distribution and design force per linear foot of wall (Fig. 1 and Fig. 2). The Contractor shall use the design force diagram to determine the number and capacity of the permanent tiebacks. The anchor zones of the tiebacks shall be at least 5 feet apart.

B. Tieback Geometry

Each tieback shall have a minimum unbonded length of 15 feet. The bonded length shall be a minimum of 10 feet. The tiebacks shall be installed at an angle varying between 10° and 30° from the horizontal. The design load for tiebacks installed at any angle varying by 1° or more from the Contractor's proposed angle of installation shall be increased or decreased. The new design load shall be sufficient to obtain or exceed the horizontal component of the proposed tieback. The Geotechnical Engineering Report shows an interpreted rockline that may be used as an aid to estimating total tieback length.

C. Geotechnical

A Geotechnical Engineering Report, which will assist the Contractor in evaluating existing conditions for design and construction, is included.

General soil and rock strata descriptions and indicated boundaries are based on an engineering interpretation of all available subsurface information and may not necessarily reflect the actual variation in subsurface conditions between borings and samples. Detailed data and field interpretation of conditions encountered in individual borings are shown on the subsurface data sheets. Drill logs, soil samples and rock cores are available for inspection at the Division of Materials.

The designer must draw his own conclusion as to the conditions to be encountered. The Department does not give any guarantee as to the accuracy of the data and no claim will be considered for additional compensation if the materials encountered are not in accord with the classification shown.

D. Drain Pipe

The 18" Reinforced Concrete Pipe at Station 236+11 will be replaced by a 24" pipe prior to construction of the permanently anchored wall. The design of the wall shall include appropriate provisions for this pipe to pass through the lagging. The channel lining required for the ditch below the pipe shall be the responsibility of the prime contractor.

The wall contractor shall be responsible for any damage to the pipe as a consequence of his wall construction.

E. Water Line

The water line at the northwest end of the wall will be relocated prior to construction of the permanently anchored wall. The wall contractor shall be responsible for any damage to the water line as a consequence of his wall construction.

F. Maintaining of Traffic

During all earth cut operations and installation of the permanent anchored wall and its component parts, the contractor shall be responsible for maintaining two lanes of traffic at all times. The contractor will be permitted shoulder closures, as necessary, through the area of construction. Where guardrail is to be removed and replaced or removed and reset, the area shall not be left unprotected over night, nor shall an exposed end of a line of guardrail be left unprotected over night. Any dropoffs shall be protected by barrels and/or vertical bridge panels.

During working hours, when it becomes necessary to work on shoulders or as otherwise directed by the Engineer, the Contractor may close one lane of traffic by the use of flagmen. However, two lanes of traffic must be in use at the end of each work day.

Traffic will be maintained in accordance with the Manual on Uniform Traffic Control Devices, current edition, and the applicable standard drawings.

All items required to "Maintain and Control Traffic" will be considered incidental to the total cost of the project.

G. Testing, Instrumentation, and Monitoring

The sections of this special note discussing testing, instrumentation, and monitoring are subject to approval by the Federal Highway Administration and may be changed, altered, or revised on the final contract plans. Additional notes and instructions are included in the attached Geotechnical memoranda. Please refer to the appropriate parts of the attached memoranda and this special note when designing the testing, instrumentation, and monitoring of this wall.

DESIGN CRITERIA

(A) Lagging shall be closed face. Lagging shall be the responsibility of the Contractor and be designed by sound engineering principles. All timber lagging shall have a uniform thickness of 4 inches or greater and a uniform width of 4 inches or greater. Timber lagging may be all softwoods or all hardwoods but shall not be a mixture of hardwoods and softwoods. Lagging shall be attached to the exposed face of the H-Piles. Bolts, threaded studs, nuts, plates, etc. shall be used to attach the lagging. The lagging shall be designed to support the cut face exposed between the soldier piles.

(B) Soldier piles shall be designed for shear, bending and axial stress. the piles will be designed to resist the resultant of the slide force as given in Figure 2. The piles shall be designed to distribute the tieback force to the soil. The soldier piles shall be driven to rock or 100 tons bearing throughout. Pile points shall be used on all piles to insure penetration into solid rock.

(C) Permanent drainage systems behind the wall shall be designed and installed by the Contractor. A preformed drain path material similar to "EnkaDrain" or "Miradrain" shall be installed behind the lagging and connected to a pipe underdrain. As lagging members are placed, the drainage material shall be installed between the soil and the lagging. A pipe underdrain shall be installed at the base of the wall to drain water away from the back of the wall. The pipe shall be connected into a system which will drain collected water away from the base of the wall.

(D) Loading conditions for the soldier piles, lagging, wales and tiebacks shall be as indicated on Figures 1 and 2.

(E) The Contractor shall be responsible for insuring that the wall is compatible with the horizontal and vertical alignment indicated on the Department's plans. The Contractor shall be responsible for the stability of the open soil cut prior to installation of the lagging. The Contractor shall not disturb the Department's Slope Inclinator Casing 37' right of Station 236+50.

(F) The design criteria for rock tiebacks are:

(1) The tieback shall be designed to provide full lateral support to the sliding mass. Theoretical and empirical methods for predicting tieback capacity shall be used for preliminary design estimate purposes only. Final tieback capacity shall be verified by field testing each tieback.

(2) The tieback structure system must be analyzed in order to insure that the anchored wall system will function as intended.

(3) The tendon size shall be determined so that the design load for the tieback does not exceed 60 percent of the guaranteed ultimate tensile strength of the tendon.

(4) The free stressing (unbonded) length shall not be less than 15 feet and shall be sufficient to insure that the entire bond length is formed in sound competent rock.

(5) The bond (anchor) length shall be estimated by the following equation:

$$L_b = p / (3.1416) (d) (t_w)$$

where:

L_b = Bond Length (not less than 10' in solid rock)

p = Design Load for tieback

d = Diameter of the drill hole

t_w = Bond stress in the interface between rock and grout.

ROCK TIEBACKS

A. Description.

A prestressed rock tieback is a high strength steel tendon, fitted with a stressing anchorage at one end and a means of permitting force transfer to the grout and rock on the other end. The rock tieback tendon is inserted into a prepared hole of suitable length and diameter, fixed to the rock, and stressed to a specified force. The basic components of a prestressed rock anchor are as listed below.

(1) Prestressing steel may be single or multiple wires, strand, or bars. The total length of the rock anchor is composed of two parts.

- a. Bonded length (anchor length) is the portion of the tieback that transmits the force to the surrounding rock.
- b. Unbonded length (stressing length) is the portion of the tieback which is free to elongate elastically during the stressing.

(2) The stressing anchorage is the device which permits the stressing and anchoring of the prestressing steel under load.

(3) The fixed anchorage is at the opposite end of the tendon than the stressing anchorage and is a mechanism which permits the transfer of the induced force to the surrounding grout or rock. Deformed bars and strand tendons do not have to have fixed anchorages since the anchor load is transferred to the grout by bond.

(4) Grout and vent pipes and miscellaneous appurtenances are required for injecting the anchor grout or corrosion protective grease. Grout may be pumped through the drill casing or rods.

(5) Prestressing steel shall be protected from dirt, rust, or other deleterious substances. (A light coating of rust on the steel will not affect its function). Heavy corrosion or pitting is cause for tendon rejection. If there is a question about the extent of the corrosion, the Department may require the steel to be tested to determine if it still meets the appropriate ASTM specification. If the steel fails to meet the minimum ASTM strengths, the Contractor shall pay all costs associated with the tests and replace the steel at his own expense.

B. Installation of Rock Tiebacks.

Installation of rock tiebacks shall be as follows:

(1) Rock cores obtained at the site are available for inspection in Frankfort, Kentucky. Contact the Division of Materials, Geotechnical Section at (502) 564-3160 to make an appointment.

(2) The holes for the tiebacks may be either driven or drilled. Core drilling, rotary drilling, auger drilling or percussion drilling may be used. If water is used in the drilling operation, the Contractor shall be responsible for disposing of the water in such a manner that erosion of the wall site is minimized. Any damage to the site by water erosion shall be repaired by the Contractor at no cost to the Department. If the hole will not stand open, casing shall be installed as required to maintain a clean and open hole. The hole diameter shall not be less than three inches if no pressure grouting is used. (Pressure grouting is defined as grouting with a pressure greater than 60 psi.) The diameter of the drill bit shall not be less than 1/8 inch smaller than the specified hole diameter. The hole shall be drilled to the inclination specified on the approved design plans within a two degree tolerance. Holes in rock shall be thoroughly cleaned of all dust, rock chips, grease or other deleterious material prior to inserting the tendon. The hole shall be of sufficient depth to insure that the bonded length is formed entirely in solid rock.

(3) The tendon shall be installed in the casing or hole drilled for the anchor. Care shall be taken to insure that the tendon's corrosion protection is not damaged during handling or installation. The tendon in the bond length shall be installed in such a way as to ensure that it has a minimum of one-half inch grout cover. The bond length of strands or wires shall be degreased prior to installation by using Acetone, MEK, or MIBK. No residue is to be left on the tendon. Other substances may be used subject to approval by the Department. All costs of cleaning tendons are to be included in the price bid for contract items.

(4) After the hole is drilled to the final depth, the tendon is inserted. Tieback tendons shall not be subjected to sharp bends. Centralizers provided at

a maximum of 10 feet center to center spacing throughout the bonded length shall be used to insure that the tendons do not contact the wall of the drill hole. Centralizers may not be of wood or any material detrimental to the tendon steel or sheathing. If multi-element tendons are used without a fixed anchorage at the lower end, provisions shall be made for adequate spacing of the tendon elements to achieve proper grout coverage. Tiebacks shall not be used for grounding electric equipment.

(5) The anchor grout shall have a water-cement ratio of 0.35 to 0.50. The grouting equipment should include a mixer capable of producing a grout free of lumps and undispersed cement. A positive displacement grout pump shall be used.

The pump shall be equipped with a pressure gauge to monitor grout pressures. The grouting equipment shall be sized to enable the tieback to be grouted in one continuous operation. Neat cement grouts should be screened to remove lumps. The maximum size of the screen openings shall be 0.250 inches (6.4 mm). Mixing and storage times should not cause excessive temperature build in the grout. The mixer should be capable of continuously agitating the grout.

The anchor grout shall be injected from the lowest point of the tieback. The grout may be placed using grout tubes, casing, or drill rods. The grout can be placed before or after insertion of the tendon. The quantity of the grout and the grout pressures shall be recorded. The grout pressures and grout takes shall be controlled to prevent excessive ground heave.

The tieback shall remain undisturbed for a minimum of three days or until the grout has cured.

The following data shall be collected by the Contractor and submitted to the Department for approval:

- a. Type of mixer
- b. Water/cement ratio
- c. Type of additives
- d. Grout pressure
- e. Type of cement
- f. Test sample strength (prior to stressing)
- g. Volume of grout placed in bonded and unbonded length separately.

MATERIALS

A. Tieback tendons shall be fabricated from single or multiple elements of the following:

- (1) Steel bars conforming to ASTM A 722, "Uncoated High-Strength Steel Bars for Prestressed Concrete";
- (2) Seven-wire strand conforming to ASTM A 416, "Uncoated Seven-Wire Stress-Relieved Strand for Prestressed Concrete";
- (3) Wires conforming to ASTM A 421, "Uncoated Stress-Relieved Wire for Prestressed Concrete"; and
- (4) Compact seven-wire strands conforming to ASTM A 779-80, "Uncoated Seven-Wire Compacted, Stress-Relieved Steel Strand for Prestressed Concrete".

The maximum load applied to the tendon shall not exceed 80 percent of the guaranteed ultimate tensile strength of the tendon. The design load shall not exceed 60 percent of the guaranteed ultimate tensile strength of the tendon.

B. Anchorages shall be capable of developing 95 percent of the guaranteed minimum ultimate tensile strength of the prestressing steel.

C. The bearing plate shall be fabricated from mild steel and it shall be capable of developing 95 percent of the guaranteed minimum ultimate tensile strength of the prestressing steel.

D. Prestressing steel couplers shall be capable of developing 100 percent of the ultimate strength of the prestressing steel.

E. Centralizers shall be fabricated from material which is nondetrimental to the prestressing steel. (Steel or plastic is commonly used. Wood shall not be used.) The centralizer shall position the tendon in the drill hole so a minimum of 0.5 inch of grout cover is provided. Pressure-injected tiebacks (effective grout pressure in excess of 150 psi) do not require centralizers.

F. Spacers shall be used to separate elements of multi-element tendons. They shall be fabricated from material which is nondetrimental to the prestressing steel. A combination centralizer-spacer can be used.

G. Type I, II, or III portland cement conforming to ASTM C 150 shall be used for grout. Cement shall be fresh and shall not contain any lumps or other indications of hydration.

H. Water for mixing grout should be potable.

I. Grout additives should be avoided. Accelerators shall not be used. Expansive admixtures may only be used for secondary grouting, and filling trumpets and anchorage covers. Admixtures which control bleed and retard set may be used. Additives shall be mixed and placed in accordance with the manufacturer's recommendations.

J. Corrosion Protection - A simple corrosion-protected tieback tendon shall be provided. Details of the protection system shall be submitted to the Engineer for review and approval. This special note schematically shows a simple corrosion protected tieback (see attached Figure 3). The ends of the grease-filled sheath shall be sealed with tape, heat-shrinkable tubes, or other

means subject to the approval of the Engineer. A plastic or steel trumpet shall be used to make the transition from the bearing plate to the corrosion protection over the unbonded length. A tight-fitting seal shall be provided at the end of the trumpet. Insulating bearing strips shall be provided under the bearing plate. The bearing strip materials must:

- be an electrical insulator;
- be resistant to attack from cement, grease, or aggressive environments;
- be nondetrimental to the prestressing steel;
- have adequate compressive strengths; and
- not be susceptible to significant creep deformations.

Manufacturer's literature describing the bearing material shall be submitted to the Engineer for review and approval.

The insulation over the anchorage and bearing plate shall be fabricated from a heat-shrinkable cap with an elastic adhesive, a moldable sealant, or other suitable material. Manufacturer's literature describing the insulation shall be submitted to the Engineer for review and approval. The anchorage insulation must be:

- an electrical insulator;
- resistant to attack from cement, grease, or aggressive environments;
- nondetrimental to the prestressing steel; and
- capable of withstanding atmospheric exposure and ultraviolet light.

The sheath or bond breaker shall be either a steel, PVC, polyethylene, or polypropylene pipe or tube. The sheath may surround individual tendon elements or the entire tendon. The material shall be capable of withstanding damage during shipping, handling, and installation. The material is subject to the approval of the Engineer.

Grease injected under the sheath shall be formulated to provide lubrication and inhibit corrosion. The chlorides, nitrates, and sulfides present in the grease shall not exceed the following limits:

Chlorides	10 ppm
Nitrates	10 ppm
Sulfides	10 ppm

The Contractor shall submit details for the grease filled sheath. The Department may randomly select for inspection two tendons per shipment. Inspection shall be by cutting open the sheath to verify whether the grease fully encapsulates the tendon and completely fills the sheath. Tendons selected for inspection may not be used in the completed wall. Unsatisfactory encapsulation or voids in the sheath may be cause for rejection of all tendons in the shipment.

K. Timber lagging shall be preservative treated in accordance with AWPA C 14 for "Piles for Foundation, Land, or Fresh Water Use". The Lagging shall conform to the grading requirements of Section 818.03.02 or Section 818.04, of the Department's 1979 Standard Specifications and shall be Grade No. 2 or better, except hardwoods shall conform to the requirements of Section 818.08

Any holes, scars, dents, scratches, scrapes, or any other puncture wounds on any face or either end of the timber lagging and any bolt holes drilled after preservative treatment shall be swabbed with preservatives identical to the preservative used for pressure treating the timber lagging. After swabbing, bolt holes for attaching lagging to piles shall be filled with a viscous tar-like material. Alternately the bolt may be coated with a viscous tar-like material and inserted into the swabbed hole or the hole may be sized so the bolt is a driving fit. In either case, after the bolt is inserted, there shall be no void spaces in the bolt hole. After the nut is tightened, the tar-like material, when used, shall ooze from both ends of the hole.

All treated timber shall be inspected by the Department of Highways or its authorized representative prior to installation in the wall. At the option of the Engineer this inspection may be at the treating plant or at the point of delivery.

When the Engineer elects to inspect the timber at the destination, the treater may hire the services of an independent timber inspection company (subject to prior approval of the Department) to provide for inspection at the treating plant which allows the material to be shipped pre-inspected.

The treater shall contact the Division of Materials, Kentucky Department of Highways, Frankfort, Kentucky 40622 (Phone 502/564-3160) at least 15 days prior to commencing an order for instructions on inspection procedures.

L. The soldier piles and wales shall conform to AASHTO M 183 for Structural Steel. All portions of the piles exposed after driving and excavation but before lagging is attached shall be coated with coal tar epoxy. Wales shall be entirely coated with coal tar epoxy.

M. Threaded studs, bolts, plates, nuts, washers, etc., wales and all other exposed hardware except the piles and wales shall be coated with a weather proof moldable mastic sealant such as Tape Coat Mastic. The mastic protectant shall be readily applicable by means of a trowel or caulking gun without pulling or drawing, and shall not sag or flow when applied.

The compound shall withstand exposure to the weather. It shall withstand freezing, snow, sleet, rain, heat from the sun and shall not exhibit any tendency to separate or otherwise deteriorate after application.

When applied and cured for 24 hours, the compound shall set to a tough, plastic coating and shall not shrink, crack or loosen from the surface.

N. All materials shall conform to the applicable Section(s) of the 1979 Kentucky Standard Specifications for Road and Bridge Construction, unless otherwise covered in this special note.

TESTING

A calibrated hydraulic jack and pump shall be used to load the tendon. The jack and pump shall be calibrated as a unit. The Contractor shall submit the calibration curve to the Engineer for approval prior to performing any tests. The total and creep movements of the tieback shall be measured to the nearest 0.0001 inch with a dial gage. The gage shall be supported on a reference independent of the tieback structure.

Each tieback shall be load-tested. The tiebacks shall be tested as soon as the grouting has obtained sufficient strength. Performance tests shall be conducted on the first five tiebacks and 5 percent of the remaining tiebacks. All other tiebacks shall be proof-tested. The first two performance tests shall be creep performance tests. Also, four creep tests shall be performed between Stations 238+00 and 240+00. The creep performance tests shall be conducted by incrementally loading, holding, and unloading the tieback in accordance with the schedule in Table I (Fig. 4). The creep movements during all load holding periods shall be plotted as a function of the logarithm of time. An acceptable creep rate for the curve obtained from this data shall be 0.08 inches per logarithm cycle of time. A minimum of four creep performance tests are required unless the first creep test are between Stations 234+80 to 238+00.

The remaining performance tests shall be conducted by incrementally loading and unloading the tieback in accordance with the schedule in Table 2 (Fig. 5). The total movement and residual anchor movement shall be plotted as a function of load for all performance tested tiebacks.

A performance-tested tieback is acceptable if:

(1) The measured elastic movements exceed 0.80 of the theoretical elongation of the unbonded length plus the jacking length at the maximum test load; and

(2) The creep movement between 1 and 10 minutes is less than 0.04 inches.

Performance-tested tiebacks which fail to meet acceptance criteria number 2 above will be accepted if the maximum load is held for 60 minutes and the creep curve plotted from the movement data indicates a creep rate of less than 0.08 inches per log cycle of time.

The remaining tiebacks shall be proof-tested. The proof test shall be performed by incrementally loading the tieback in accordance with the schedule in Table 3 (Fig. 6). The total movement shall be plotted as a function of load for each proof-tested tieback. If the movement during the five-minute observation period is less than 0.03 inches, the test can be discontinued. If the movement exceeds 0.03 inches, the load shall be maintained until the creep rate can be determined. A proof-tested tieback is acceptable if:

(1) The creep movement between 1 and 5 minutes is less than 0.03 inches; and

(2) The pattern of movements is similar to adjacent performance tests.

Proof-tested tiebacks which fail to meet the above acceptance criteria will be acceptable if the load is maintained until a creep rate is determined and that rate is less than 0.08 inches per log cycle of time.

All tiebacks shall be subjected to lift-off tests. For all tiebacks, after transferring the load to the end anchorage and prior to removing the jack, a lift-off reading shall be made. The load determined shall be within 5% of 1.00PDL. If the lift-off load is less than 0.95PDL the end anchorage shall be reset and another lift-off reading made. Lift-off tests shall be performed within 7 days of when the load was locked-off in the anchor.

After five lift-off tests are performed, the Contractor will perform lift-off tests on a random basis such that the total number of tests will be performed on no less than 10% of the remaining anchors.

CUTTING OF TENDON PROTRUSIONS

After a tieback has been accepted by the Department, the portion of the anchored tendon protruding over the anchor may be cut, if not otherwise required for use in retesting. Cutting shall be done according to the tendon manufacturer's recommendations and as approved by the Engineer. Care shall be taken not to damage the tendon anchor.

REDESIGN

If tiebacks fail during creep tests, performance tests, or proof tests, the Contractor shall modify the design or construction procedures, subject to review and approval by the Engineer. These modifications may include reducing the tieback design load by increasing the number of tiebacks, increasing the anchor diameter or increasing the bond length. Any modification of design or construction procedure shall be at no additional cost to the Department. The redesigned anchors shall be installed in the wall and tested as previously defined at no additional cost to the Department. Those tiebacks that fail the performance or proof tests may be incorporated in the wall. The Contractor shall propose a reduced Design Load and retest as noted above. Acceptance of such tiebacks will be at the discretion of the Department. Any changes or modifications of the method of installation or tieback type shall require additional creep or performance testing as directed by the Engineer.

INSTRUMENTATION

At the option of the Department, devices to monitor ground and wall movements during and after construction will be installed by the Department during the construction of the wall. The Contractor shall cooperate with the instrumentation installers. The Department will schedule these installations to

minimize interference with the Contractor's operations. Delays of one working day per instrument installation can be anticipated. The Division of Materials shall notify the Contractor one week in advance of any Department installed instrumentation that may disrupt Contractor operations by four hours or more. The notification shall include location, type and estimated construction time delay.

Although the Geotechnical Section personnel will be responsible for maintaining the instruments, the Contractor will be responsible for any damage which occurs to the instruments, connections or readouts as a result of operations of the Contractor or his subcontractors. The Contractor shall replace and install such equipment in a manner acceptable to the Department and at no cost to the Department.

MONITORING

Permanent load cells and extensometers shall be provided where indicated in the Geotechnical memoranda. The Contractor shall read the instrumentation weekly during construction. Upon completion of construction, the Contractor shall turn over to the Department the readout equipment required to continue monitoring. This equipment shall become the property of the Department.

RECORDS

The Contractor shall provide the Department with the following records:

- (1) Drawings showing the location of the tiebacks, total tieback length, bonded length, and unbonded length.
- (2) Steel and grout certifications and/or mill reports.
- (3) Grouting records indicating the cement type.

- (4) The Contractor shall show on his drawings the type of testing to be performed for each tieback.
- (5) Tieback test results.
- (6) Monitoring results.
- (7) The Contractor shall show on his drawings the locations of all instrumentation to be installed by the Contractor and the Department.

MEASUREMENT AND PAYMENT

The accepted anchored wall will be measured as a lump sum at each location. Payment at the contract unit price shall be full compensation for all costs for excavation, backfill, lagging, wales, piles, tiebacks, labor, design, instrumentation, monitoring, and all other materials and equipment including grouting drilling holes, post-tensioning, corrosion protections, performing and evaluating all tests, submitting records of tests, all tools and all other miscellaneous items necessary to complete the work.

Additional area of wall required due to unforeseen foundation conditions or other reasons and approved in writing by the Engineer will be paid for by proportionally increasing the Lump Sum Price Bid for the Wall.

In the event a decrease in the area of the wall is required, subject to approval by the Engineer, the Lump Sum Price Bid shall be adjusted proportionally to the decrease in wall area.

The increase/decrease in price shall equal the increased/decreased area multiplied by Lump Sum Price Bid divided by the original plan area of facing.

All measurement shall be based on plan dimensions or dimensions as ordered in writing.

Payment shall be made under:

<u>Pay Item</u>	<u>Pay Unit</u>
Item Code No. 89 <u>40</u> , Permanent Anchored Wall	Lump Sum.

July 29, 1983

LOAD CASE 1 - SOLDIER PILES w/LAGGING
DURING CONSTRUCTION BEFORE TIEBACKS *

* AFTER RETAINING WALL DESIGN GUIDE, USDA FOREST SERVICE

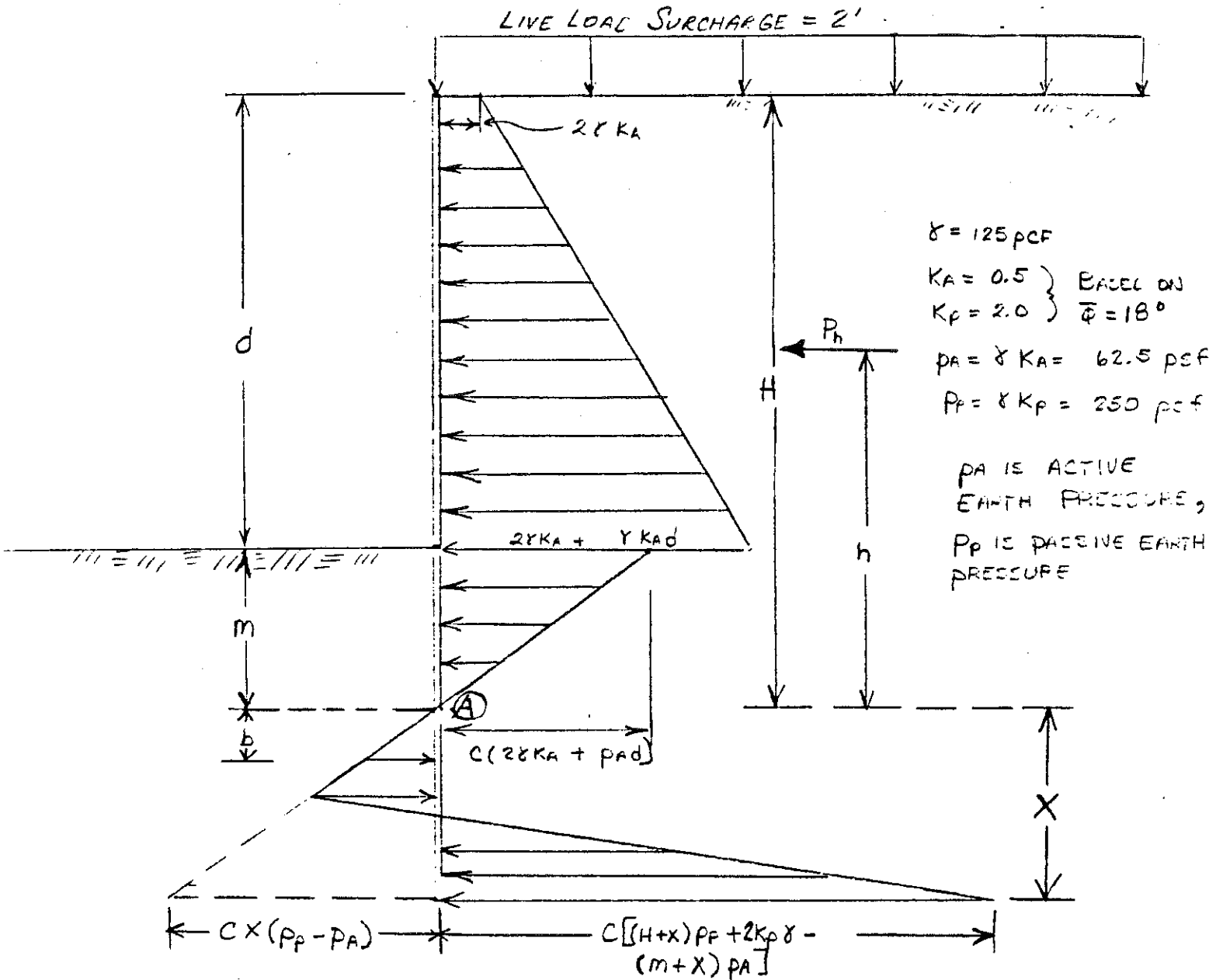

$$C = \frac{\text{PILE WIDTH [FT]}}{\text{C-C PILE SPACING [FT]}}$$

DEPTH WHERE ACTIVE AND PASSIVE STRESSES - M

$$M = \frac{2\gamma K_A + \gamma K_A d}{P_P - P_A}$$

$$P_h = 2\gamma d K_A + \frac{\gamma A d^2}{2} + \frac{(2\gamma K_A + \gamma K_A d)}{2}$$

FOR DEPTH BELOW PT. A TO PT. OF ZERO SHEAR, MAXIMUM BENDING MOMENT

Compute depth below \textcircled{A} to pt. zero shear

$$b = \sqrt{\frac{2 P_h}{(P_p - P_a) C}}$$

This is also pt. of Max. Bending Moment

Compute Max. Bending Moment per foot of wall (M):

$$M_{\text{max}} = P_h (h + b) - \frac{b^3}{6} (P_p - P_a) C$$

Compute Minimum Required Section Modulus, S_{min} , per pile:

$$S_{\text{min}} = \frac{M_{\text{max}}}{F_b} \times S,$$

WHERE S = PILE SPACING AND
 F_b = MAX. BENDING STRESS

TYPICAL SECTION OF WALL

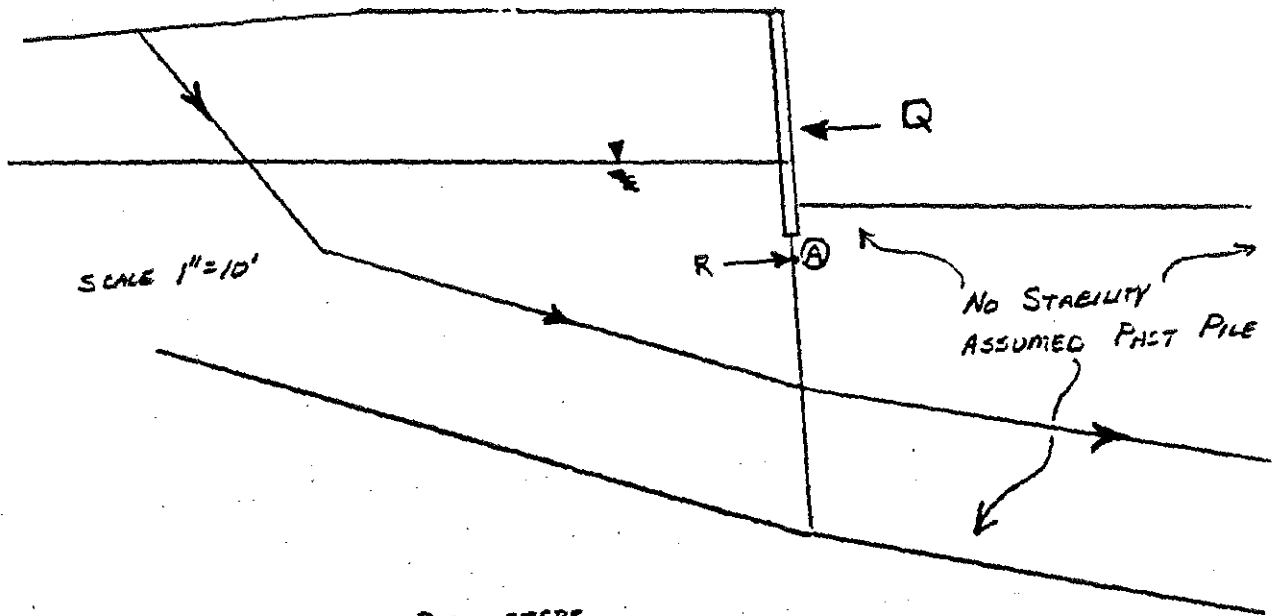

SOIL STRENGTH PARAMETERS

$$\bar{c} = 0 \text{ psf}$$

$$\bar{\phi} = 18^\circ$$

R - THE RESULTANT OF SLIDE FORCES

Q - THE MAGNITUDE OF RESTRAINT FORCES + SOIL FRICTION

Ⓐ - ESTIMATED POSITION OF RESULTANT FORCES

$$R = 34.62 \text{ K/FT}$$

$$\text{SOIL FRICTION} = 18.75 \text{ K/FT}$$

FOR F.S. = 1.5, FIND Q

$$(1.5)(34.62) = Q + 18.75$$

$$\underline{\underline{38 \text{ K/FT} = Q}}$$

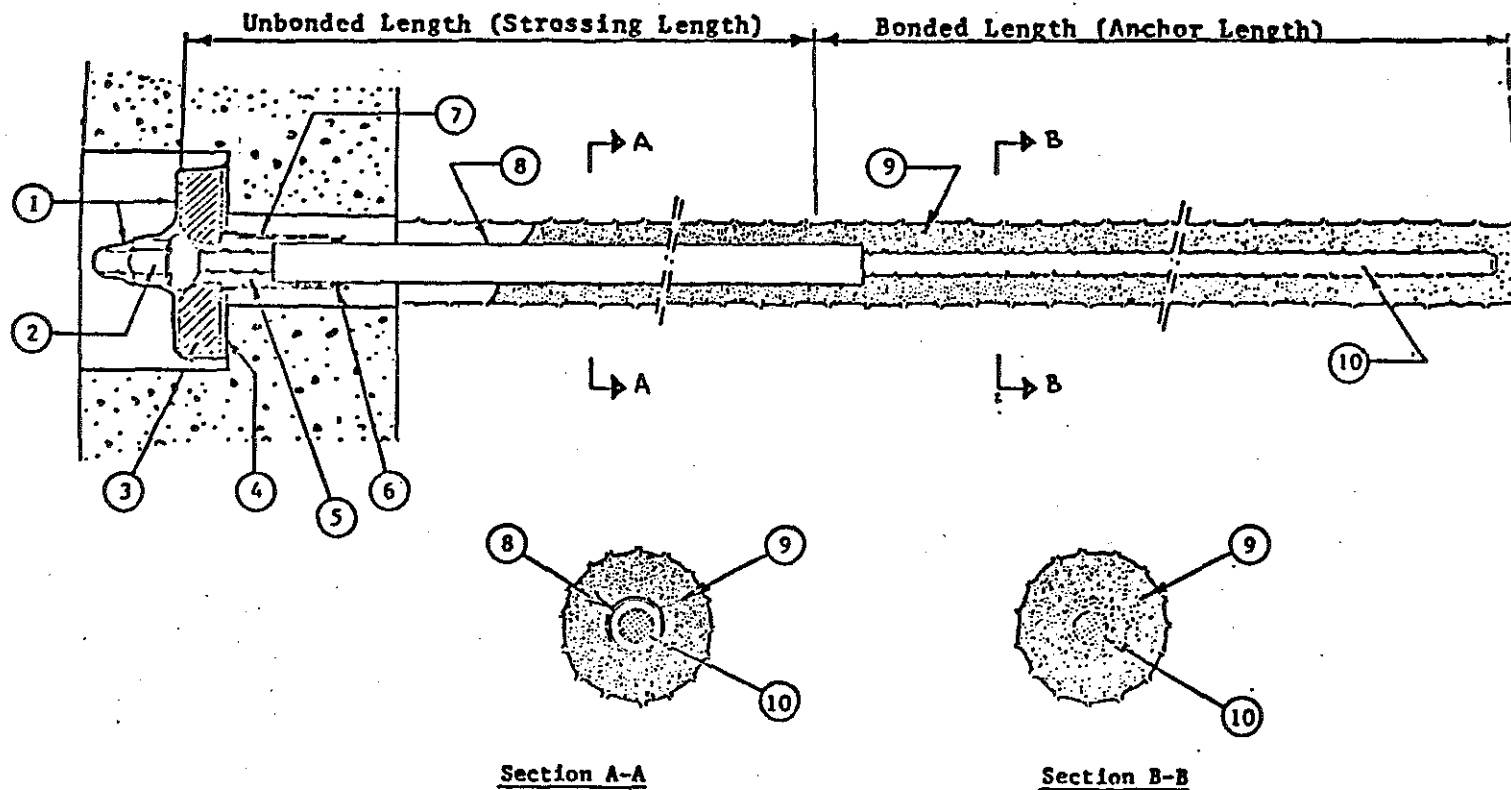

Legend:

- | | |
|--|---|
| 1) Insulating cover of preformed plastic, heat shrinkable cover, or moldable tape. | 6) Seal |
| 2) Nut | 7) PVC trumpet |
| 3) Bearing plate | 8) Grease filled PVC or polyethylene sheath |
| 4) Bearing plate insulation | 9) Anchor grout |
| 5) Anticorrosion grease | 10) Tendon |

Figure 3. Insulated simple corrosion protected (single protected) tieback.

CREEP TEST SCHEDULE

Load increment	Basis of load	Load (tons)	Jack pressure (psi)	Load cell (μt)(3)	Movement (inches)	Observation periods (min)	Remarks
0	0						
TO	(1)					10	
P1	0.25 PDL						
TO							
P1	0.25 PDL					30	
P2	0.50 PDL						
TO							
P1	0.25 PDL						
P2	0.50 PDL					30	
P3	0.75 PDL						
TO							
P1	0.25 PDL						
P2	0.50 PDL						
P3	0.75 PDL						
P4	1.00 PDL					45	
TO							
P1	0.25 PDL						
P2	0.50 PDL						
P3	0.75 PDL						
P4	1.00 PDL						
P5	1.20 PDL					60	
TO							
P1	0.25 PDL						
P2	0.50 PDL						
P3	0.75 PDL						
P4	1.00 PDL						
P5	1.20 PDL						
P6	1.33 PDL					300	
P6	1.33 PDL					2	
P6	1.33 PDL					3	
P6	1.33 PDL					4	
P6	1.33 PDL					5	
P6	1.33 PDL					7	
P6	1.33 PDL					10	
P6	1.33 PDL					15	
P6	1.33 PDL					20	
P6	1.33 PDL					25	
P6	1.33 PDL					30	
P6	1.33 PDL					45	
P6	1.33 PDL					60	
P5	1.20 PDL						
P4	1.00 PDL						
Lock-Off							

(1) TO is the alignment load. It is normally between 2 and 10 percent of the design load and it is maintained in order to keep the testing equipment aligned. The actual value of this load depends upon the type of tendon and weight of the jack.

PDL = design load.

(3) μt = microstrains (10⁻⁶ inches).

FIGURE 4

PERFORMANCE TEST SCHEDULE

Load increment	Basis of load	Load (tons)	Jack pressure (psi)	Load cell ($\mu\epsilon$) (3)	Movement (inches)	Observation periods (min)	Remarks
0	0						
T0	(1)						
P1	0.25 PDL						
T0							
P1	0.25 PDL						
P2	0.50 PDL						
T0							
P1	0.25 PDL						
P2	0.50 PDL						
P3	0.75 PDL						
T0							
P1	0.25 PDL						
P2	0.50 PDL						
P3	0.75 PDL						
P4	1.00 PDL						
T0							
P1	0.25 PDL						
P2	0.50 PDL						
P3	0.75 PDL						
P4	1.00 PDL						
P5	1.20 PDL						
T0							
P1	0.25 PDL						
P2	0.50 PDL						
P3	0.75 PDL						
P4	1.00 PDL						
P5	1.20 PDL						
P6	1.33 PDL					1	
P6	1.33 PDL					2	
P6	1.33 PDL					3	
P6	1.33 PDL					4	
P6	1.33 PDL					5	
P6	1.33 PDL					7	
P6	1.33 PDL					10	
P6	1.33 PDL					15	
P6	1.33 PDL					20	
P6	1.33 PDL					25	
P6	1.33 PDL					30	
P6	1.33 PDL					45	
P6	1.33 PDL					60	
P5	1.20 PDL						
P4	1.00 PDL						
Lock-Off							

(1) T0 is the alignment load. It is normally between 2 and 10 percent of the design load and it is maintained in order to keep the testing equipment aligned. The actual value of this load depends upon the type of tendon and weight of the jack.

(2) PDL = design load.

(3) $\mu\epsilon$ = microstrains (10^{-6} inches).

FIGURE 5

PROOF TEST SCHEDULE

Load Increment	Basis of load	Load (tons)	Jack pressure (psi)	Load cell ($\mu\epsilon$) (3)	Movement (inches)	Observation periods (min)	Remarks
0	0						
T0							
P1	0.25 PDL						
P2	0.50 PDL						
P3	0.75 PDL						
P4	1.00 PDL						
P5	1.20 PDL					0	
P5	1.20 PDL					1	
P5	1.20 PDL					2	
P5	1.20 PDL					3	
P5	1.20 PDL					4	
P5	1.20 PDL					5	
P5	1.20 PDL					7	
P5	1.20 PDL					10	
P5	1.20 PDL					15	
P5	1.20 PDL					20	
P5	1.20 PDL					25	
P5	1.20 PDL					30	
P5	1.20 PDL					45	
P5	1.20 PDL					60	
P4	1.00 PDL						
Lock-Off							

- (1) T0 is alignment load. It is normally between 2 and 10 percent of the design load and it is maintained in order to keep the testing equipment aligned. The actual value of this load depends upon the type of tendon and weight of the jack.
- (2) PDL = design load.
- (3) $\mu\epsilon$ = microstrains (10^{-6} inches).

FIGURE 6



JAMES F. RUNKE
SECRETARY

COMMONWEALTH OF KENTUCKY
TRANSPORTATION CABINET
FRANKFORT, KENTUCKY 40622

JOHN Y. BROWN, JR.
GOVERNOR

August 23, 1983

Specialty Contractors
Permanent Anchored Walls

In Re: Carroll County, SR 5167 001
FSP 021 0227 000-005 010 D
Permanent Anchored Wall
Correction of Slide #2, KY 227
Station 234+80 to 240+00
Item Number 6-187.0
Addendum

Gentlemen:

This addendum addresses some questions which were posed by various specialty contractors and other interested individuals concerning the design of this wall.

Contrary to the August 3, 1983 memorandum from J. C. Hawkins, your design and plans will not be included in the contract plans. Instead, you will be identified as a prequalified contractor with an approved design and set of plans for construction of this wall. However, we will still require reproducible copies of your plan by September 23, 1983. Furthermore, the letting date for this project is September 18, 1983; not September 11, 1983.

Item (A) of Design Criteria on page 4 of the "Special Note" states that the lagging shall be closed face. This is being changed to open faced lagging. A uniform gap of 1 to 2 inches shall be permitted throughout. Additionally, the lagging shall be designed for 1.5 times the design load (1.5 PDL) to prevent cracking of the lagging when the tiebacks are stressed. Also, any areas behind the lagging requiring backfilling shall be backfilled and compacted prior to applying any loads to the tiebacks.

Item (B) of Design Criteria on page 4 of the "Special Note" refers to pile tip reinforcement. They are necessary to ensure driven piles penetrate a boulder layer above the rock line. If the wall is designed with one row of tiebacks, the soldier piles shall be cored a minimum of 10 feet into bedrock throughout and pile tip reinforcement will not be required. If the wall is designed with two or more rows of tiebacks, the soldier piles shall be driven to rock or 100 tons refusal throughout and pile tip reinforcement will be required.

Item (C) of Design Criteria on page 5 of the "Special Note" discusses the drainage requirements. The drain path material shall have the side against the earth cut covered with a geotextile filter fabric. The Geotechnical Memorandum dated July 29, 1983 includes a drawing of the proposed drainage for the tieback wall. The soldier piles are not to be cut for drainpipe installation. The drainpipe may be placed in sections between the piles or placed continuously in front of the piles. Additionally, the plastic trough called for in Item (5) of the July 29, 1983 Geotechnical memorandum shall meet the material requirements of AASHTO M252 and may be fabricated from corrugated polyethylene pipe.

Item (F) (5) of Design Criteria on page 6 of the "Special Note" should be omitted and replaced with 'The contractor shall be responsible for determining the bond length in rock (not less than 10 feet into solid rock) necessary to develop the design load he selects for the anchor.'

-Item (5) f. of Installation of Tiebacks on page 10 of the "Special Note" includes data collection requirements for the grout used on the project. Item f - Test sample strength (prior to stressing) - is not required.

Item L. of Materials on page 14 of the "Special Note" states that the exposed face of the piles and the entire wales be coated with coal tar epoxy. We are considering changing this to a weather proof moldable mastic sealant as is described in Item M. We are also considering specifying that all hardware be galvanized or be painted with a high quality bridge paint. A decision will be made as soon as possible.

Specialty Contractors
August 23, 1983
Page #3

The following is excerpted from Geotechnical Engineering Report "L-19-82" Section II, titled "Geology and Topography":

'The subject slide is situated in the northern part of the Outer Bluegrass topographic region of Kentucky. The rocks encountered in the area are predominately interbedded limestone and shales of Ordovician Age. Glacial deposits and recent alluvium are present in many areas adjacent to the river.

The main rock formation in the region is the Kope Formation, a problem-maker, well documented in engineering and geological literature.'

The shale is probably a clay shale subject to rapid disintegration when exposed to air and water. This shale is locally known as Kope or Eden shale.

Your input and suggestions on any of these comments or on any part of the "Special Note" is solicited.

Yours very truly,



T. R. Layman, P.E.

Director

Division of Bridges

TRL/HP/rrm



JAMES F. RUNKE
SECRETARY

COMMONWEALTH OF KENTUCKY
TRANSPORTATION CABINET
FRANKFORT, KENTUCKY 40622

JOHN Y. BROWN, JR.
GOVERNOR

September 21, 1983

Specialty Contractors
Permanent Anchored Walls

In Re: Carroll County, SR 5167 001
FSP 021 0227 000-005 010 D
Permanent Anchored Wall
Correction of Slide #2, KY 227
Station 234+25 to Station 244+25
Item No. 6-167.0
Addendum #2

Gentlemen:

This addendum contains modifications, changes, deletions, etc., to the "SPECIAL NOTE" for the permanent anchored wall on the project. This is a result of a review of the designs submitted by Specialty Contractors, FHWA input, new conditions, etc. This addendum and the addendum dated August 23, 1983 become part of the "SPECIAL NOTE" for this project.

The overall project provides for the resurfacing and shoulder restoration of US 227 from the end of the curb and gutter section in Carrollton and extending westward to approximately 1.0 mile west of the Owen-Carroll County Line, a total distance of approximately 7.80 miles. Included within this distance is the repair of two (2) slides. The Permanent Anchored Wall is for correction of Slide #2 of the overall project.

The lateral extent of Landslide #2 has changed. Consequently, the limits of the wall have been increased. This wall will be constructed right of KY 227 from about Station 234+25 to about Station 244+25. New cross sections are attached. These new cross sections cover the new wall limits and also include geotechnical information obtained for the project. These cross sections replace and supercede the cross sections received with the "SPECIAL NOTE".

Item A. Tieback Capacity on Page 2 of the "SPECIAL NOTE" refers to the design force per linear foot of wall. This was given in Figure 2 of the "SPECIAL NOTE". This figure is to be replaced by the attached pressure diagram. The landslide force is assumed to act over the entire portion of the pile above the failure plane. The contractor shall use this new diagram for the design of the permanent anchored wall. The contractor shall also check the adequacy of his wall during various phases of construction. As a minimum, the contractor shall check; 1) the cantilevered condition prior to the first anchor installation and 2) the condition with the top anchor installed and excavation sufficient for installation of the second anchor.

The design of the wall shall also include a check of moment stability. If the anchors cannot be positioned to satisfy moment equilibrium, the piles may be cored into rock and the passive resistance in the rock may be considered. The pile shall be socketed into rock with Class A Concrete. The passive resistance developed in the rock may be assumed to develop over three (3) times the width of the concrete socket.

Item D. Drain Pipe on Page 3 of the "SPECIAL NOTE" should include the following. The design of the wall shall include appropriate provisions for the 18" reinforced concrete pipe to pass thru the lagging. The channel lining required for the ditch below the pipe shall be the responsibility of the prime contractor.

The wall contractor shall be responsible for any damage to the pipe as a consequence of his wall construction.

Item (A) of DESIGN CRITERIA on Page 4 of the "SPECIAL NOTE" and our addendum dated August 23, 1983 discuss the design of the timber lagging for this wall. The following is to be included. The contractor shall design the timber lagging for 1.33 times the anchor design load (not 1.5 times the design load). The contractor shall design the timber lagging for both the short term and the long term condition. The lagging may be designed for two-thirds of the maximum moment for both cases. For the short term condition, a uniform load equivalent to 1.33 times the anchor design load shall be used. The allowable unit stress shall be increased (+ 33%) in accordance with Section 1.10.1 (E) of the Current Edition of the AASHTO Standard Specifications for Highway Bridges. For the long term condition, a uniform load equivalent to the anchor design load shall be used. The allowable unit stress shall be decreased (- 10%) in accordance with Section 1.10.1 (D) of the Current Edition of the AASHTO Standard Specifications for Highway Bridges. Arching action shall not be assumed for either condition. The actual measured dimensions of the delivered lagging, corrected for estimated shrinkage, shall equal or exceed the design dimensions of the lagging.

Specialty Contractors
Page three
September 21, 1983

Item (3) of DESIGN CRITERIA on Page 4 of the "SPECIAL NOTE" discusses the design of the soldier piles. The piles, wales, anchor plates, anchor heads, bearing plates and other structural hardware shall be designed in accordance with the Current Edition of the AISC Steel Construction Manual. The depth the piles are cored into rock shall be determined in accordance with the attached pressure diagram. The rock socket shall be filled with Class A Concrete.

Figure 2 referred to in Item (D) on Page 5 of the "SPECIAL NOTE" shall be replaced by the attached pressure diagram. (This is the same figure as mentioned previously).

Item (1) on Page 7 of the "SPECIAL NOTE" should have been included in Item C. Geotechnical on Page 2.

Item (4), Page 9 of the "SPECIAL NOTE" should include the following: Welding electrodes shall not be attached to any conductor within 2' of any tieback.

Item (5), Page 9 of the "SPECIAL NOTE" discusses the water-cement ratio for the grout. The water-cement ratio shall be between 0.40 and 0.60.

Item I., Page 11 of the "SPECIAL NOTE" should include the following: Resin, epoxy or other non-cementation grouts are not permitted.

Item J., Corrosion Protection on Page 12 of the "SPECIAL NOTE" discusses the trumpet and insulating bearing strip under the bearing plate. The trumpets shall fit tightly to the bearing plates such that no voids exist between the bearing plates and trumpets. The insulating bearing strips under the bearing plates are an optional item.

Item K., Pages 13 and 14 of the "SPECIAL NOTE" discusses timber lagging. The contractor shall replace, at no cost to the Department, any lagging damaged during anchor test loading and/or before the construction contract is terminated. Damage shall include structural distress which, in the opinion of the engineer, is deleterious to the satisfactory long term performance of the wall and/or cracking which penetrates the wood preservative and exposes untreated wood.

When the treater elects to hire an independent timber inspection company, it will be at no additional cost to the Department. In certain instances, Department personnel may be available to provide inspection at the treating plant. The contractor may contact Jim Stone at (502) 564-3160 to determine if the Department can provide this service to the treater the contractor has selected.

Specialty Contractors
Page four
September 21, 1983

Item L., Page 14 of the "SPECIAL NOTE" discusses coating of the piles and wales. As an alternate material, a tape coat mastic, as specified in Item M., may be used. The tape coat mastic may be sprayed or brushed on (this applies to Item M. also). The coal tar epoxy may be coated in the shop or field applied. If shop applied, sufficient coal tar epoxy or tape coat mastic shall be available for field touch-up of nicks and scratches. For field application, the exposed surfaces shall be wire brushed clean of any loose rust, mill scale or any other deleterious material before application of the coal tar epoxy or tape coat mastic and all nicks, scratches, etc., shall be touched-up as directed by the engineer.

The TESTING section on Pages 15 and 16 of the "SPECIAL NOTE" should include the following: The soldier piles shall not deflect more than 2" horizontally. If necessary, testing may be delayed and anchors stressed in stages as excavation in front of the wall proceeds. If necessary, when a tieback has already been tested, tieback stress may be reduced to prevent 2" of horizontal deflection. The tieback will not require re-testing when it is restressed to its design load.

Delete the last line of the next to last paragraph and the entire last paragraph on Page 16 and add the following: Additional lift-off tests shall be performed after the load has been locked-off in the anchor at least seven (7) days. After five (5) of these lift-off tests have been performed, the contractor shall perform lift-off tests on a random basis such that the total number of these tests are performed on no less than 10% of the remaining anchors. Tendon cutting shall be delayed until this series of lift-off testing is completed. NOTE: This series of lift-off testing is in addition to the initial lift-off testing of all tiebacks.

Upon our receipt, the proposed "Federal Task Order" prepared by the Kentucky Transportation Research Program will be forwarded to you. This proposal shall be considered part of the "SPECIAL NOTE" for this project. The contractor shall provide four (4) load cells as per this proposal. The contractor shall provide the appropriate readout equipment for these load cells. These load cells and the readout equipment shall become the property of the Department. The cost of these items are incidental to the wall and shall be included in the lump sum price for the wall.

In accordance with Section 3). of the July 29, 1983 Geotechnical Memorandum, a special note with instructions for use of the "Pile Wave Equation" is attached. This is for our information only. All aspects of pile driving shall be in accordance with the appropriate sections of the 1983 Edition of Kentucky's "Standard Specifications for Road and Bridge Construction". (If no pile driving is to be done for construction of this wall, this submission is unnecessary).

SPECIAL NOTE

PILE WAVE EQUATION

All pile driving equipment to be furnished by the contractor shall be subject to the approval of the engineer. Prior to such approval, the contractor shall submit the following:

- (a). A completed "Pile and Driving Equipment Data" form for each hammer proposed for the project (a copy of the data form is attached.)

The equipment specified on the "Pile Driving and Equipment Data" form shall be used in the field. Any changes or deviations in equipment from that described on the form shall require prior written approval from the Division of Construction.

APPENDIX B
DESIGN CALCULATIONS
FOR
PERMANENT ANCHORED WALL
CORRECTION OF SLIDE #2
KY 227, CARROLL CO., KY

Schnabel
FOUNDATION COMPANY

RECEIVED

OCT 11 1983

DIVISION OF BRIDGES
FRANKFORT, KENTUCKY

DESIGN CALCULATIONS
PERMANENT ANCHORED WALL
Correction of Slide #2
KY227, Carroll Co., KY

October 6, 1983

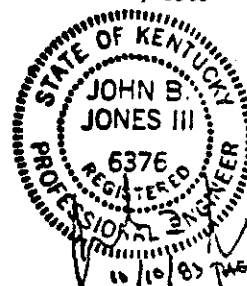

BASIS OF DESIGN

1. The design of the tiedback wall is based on an estimated restraint force for a safety factor of 1.5 of 33 kips per LF of wall where the slide has a maximum depth of 25 ft. below the top of the wall. This design restraint force was redistributed as a uniform loading diagram over the wall height above the slide surface. To compute the loading conditions from this diagram, a hinge is assumed at subgrade and at each support except for the top support; thereby complying with the derivation of the loading envelope. The loading diagram is shown on pages 3 and 4 and the design values are taken from a computer printout. The uniform loading for the 25 ft. slide depth is $p = 33/25 = 1.32$ ksf, which is equivalent to $p = 0.0528$ k/ft. $\times H$ ($1.32/25 = 0.0528$). For other slide depths, a uniform loading diagram with $p = 0.0528 H$ was utilized.

The values for B1 and B2 are given in K/ft. of wall, moments in K-ft./LF of wall. Only the critical moment is shown in our computation.

2. No hydrostatic pressure is assumed since the system is free-draining.

3. The wall system was designed only for the assumed slide depth (H) to support the landslide loading condition ($p = 0.0528H$). By inspection, the following intermediate loading conditions for normal earth pressures ($p = 0.020 h$, where $h =$ intermediate excavation depth) are not critical:

- a. Cantilevered condition prior to the first tieback level installation. ($h = H1$)
- b. Condition with the top tieback level installed and excavation sufficient for installation of second level of tiebacks. ($h = H1 + H2$)

4. The soldier beams and wales are designed according to the A.I.S.C. Code. Soldier beams are considered fully braced in the plane of the sheeting wall; therefore, $F_b = 0.66F_y$. This reduction is explained in "Foundation Engineering: by Peck, Hanson and Thornburn, 2nd Edition, page 463 which states: "The soldier piles need not be designed for the full bending moment corresponding to the pressure given by the diagram."

Midwest Region—Chicago: 210 Cleveland Street, Cary, Illinois 60013 - (312) 639-8900
Corporate office: Bethesda, MD Regional offices: Washington, Philadelphia, Atlanta, Chicago

Page 2

5. The wall friction acts to decrease the axial loading in the soldier beam. No axial loading is considered until the angle of the tieback from the soldier beams exceeds 30° .

6. Soldier beam toe embedment resistance consists of the length through the stable overburden zone below the slide surface and the sliding resistance of the pile tip on the top of rock. The soldier beams will be driven with pile points to practical refusal.

Schnabel

FOUNDATION COMPANY

Calculation Sheets

Project Permanent Anchored Wall-Correction of Slide #2

Contract No. _____

Location KY227, Carroll Co., KY

Sheet No. 3

Architect/Engineer KDOT

Date 10/6/83

General Contractor _____

By TCA

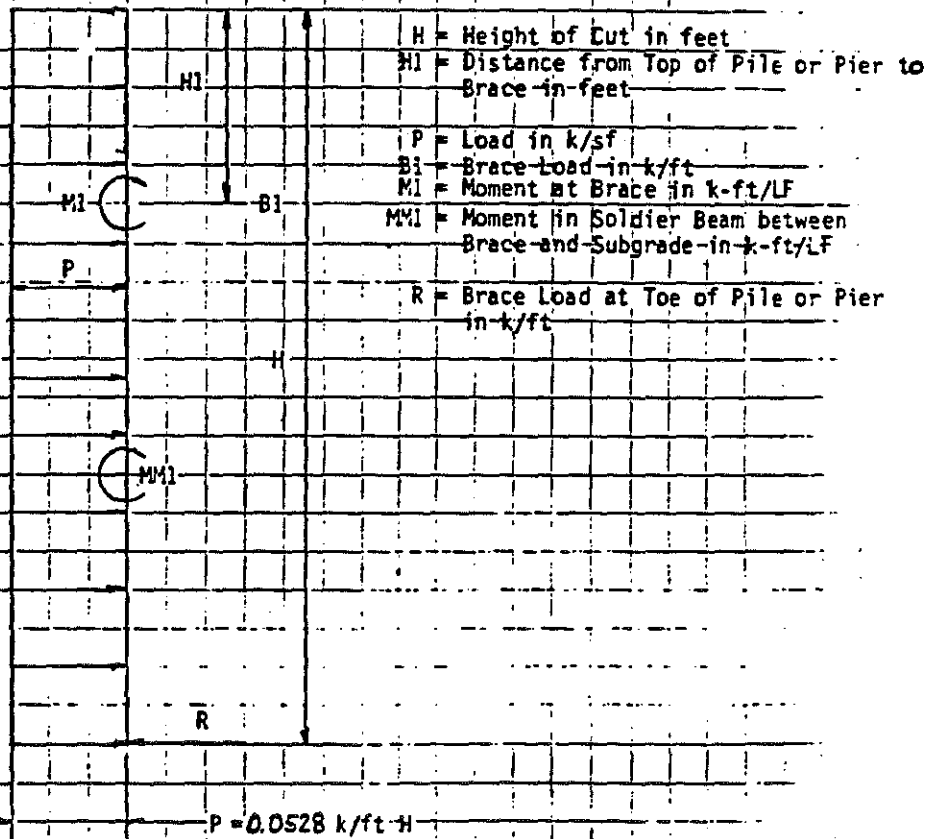

Schnabel

FOUNDATION COMPANY

Calculation Sheets

Project Permanent Anchored Wall-Correction of Slide #2

Contract No. _____

Location KY227, Carroll Co., KY

Sheet No. 4

Architect/Engineer KDOT

Date 10/6/63

General Contractor _____

By TCA

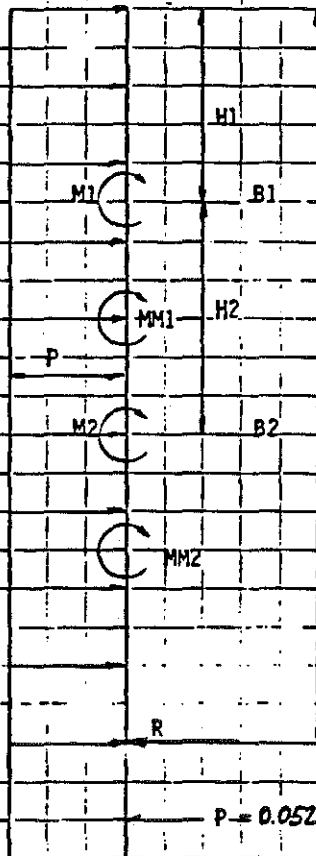

- H = Height of Cut in feet
- H1 = Distance from Top of Pile or Pier to 1st Tier Brace in feet
- H2 = Distance from 1st Tier Brace to 2nd Tier Brace in feet
- P = Load in k/sf
- B1 = 1st Tier Brace Load in k/ft
- B2 = 2nd Tier Brace Load in k/ft
- M1 = Moment at 1st Tier Brace in k-ft/ft
- MM1 = Mid Span Moment between 1st and 2nd Tier Braces in k-ft/ft
- M2 = Moment at 2nd Tier Brace in k-ft/ft
- MM2 = Mid Span Moment between 2nd Tier Brace and Subgrade in k-ft/ft
- R = Brace Load at Toe in k/ft

Project Permanent Anchored Wall - Correction of Slide #2
 Location KY 227, Carroll Co., KY
 Architect/Engineer KDOT
 General Contractor _____

Contract No. _____
 Sheet No. 5
 Date 10/6/53
 By TCA

1 2 3 4 5 6 7 8 9 10 11 12 13 14 15 16 17 18 19 20 21 22 23 24 25 26 27 28 29 30 31 32

25' Slide Depth - SB #9-22

$p = 0.0528 \times 25' = 1.32 \text{ ksf}$
 total force = $1.32 \times 25 = 33 \text{ k/LF}$
SB @ 8' o.c.

$H = 25', H_1 = 5', H_2 = 10'$

$B_1 = 14.85 \text{ k/LF}$ $M_1 = MM_2 = 16.5 \text{ k-F/LF}$
 $B_2 = 11.55 \text{ k/LF}$

Check Moment Equilibrium about toe of SB :

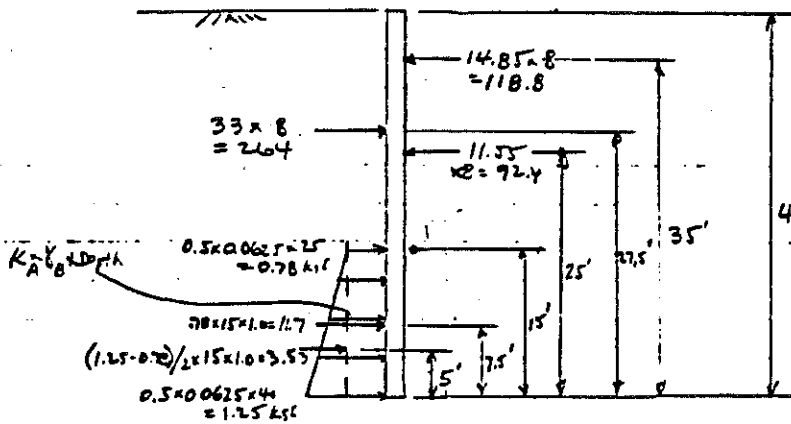

$K_A = 0.5$
 $\delta_B = 0.0625 \text{ per}$
 pile width = 1.0'

$\Sigma M = 264 \times 27.5 + 11.7 \times 7.5 + 3.53 \times 5' - (118.8 \times 35 + 92.4 \times 25)$
 $= 7365.4 - 6468 \rightarrow \frac{7365.4}{6468} = 1.14$

∴ Multiply B_1 and B_2 by 1.14 for moment equilibrium

SB $S_{A36} = \frac{16.5 \times 8 \times 12}{14} = 66.0 \text{ in}^2$

use HP12x53

Ties $B_{1_{30}} = \frac{14.85 \times 1.14 \times 8}{0.866} = 156 \text{ k}$

use 5-0.6" strands (270ksi) even.
SB

$B_{2_{30}} = \frac{11.55 \times 1.14 \times 8}{0.866} = 122 \text{ k}$

use 4-0.6" strands (270ksi) even.
SB

Project Permanent Anchored Wall - Correction of Slide #2
 Location KY 227, Carroll Co., KY
 Architect/Engineer KDOT
 General Contractor _____

Contract No. _____
 Sheet No. 6
 Date 10/6/23
 By TCA

1 2 3 4 5 6 7 8 9 10 11 12 13 14 15 16 17 18 19 20 21 22 23 24 25 26 27 28 29 30 31 32

20' Slide Depth - SB #23-72

$P = 0.0529 \times 20' = 1.056 \text{ ksf}$
 $\text{total force} = 1.056 \times 20' = 21.12 \text{ k/LFF}$
 SB @ 8' o.c.

$H = 20', H1 = 4', H2 = 7.5'$

$B1 = 9.31 \text{ k/LF}$

$MM2 = 9.54 \text{ k-ft/LF}$

$B2 = 7.32 \text{ k/LF}$

Check moment equilibrium about toe of SB:

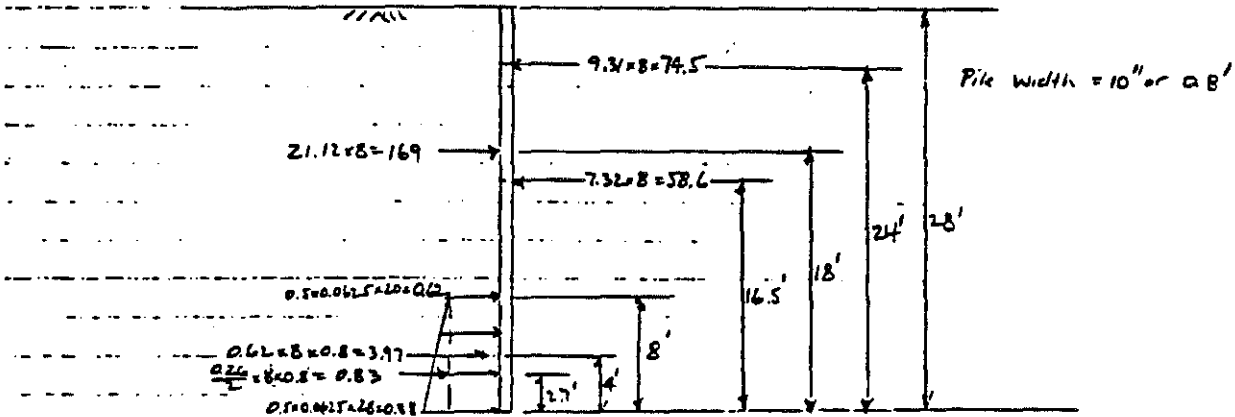

$$\Sigma M = 169 \times 18' + 3.97 \times 4' + 0.83 \times 2.7' - (74.5 \times 24' + 58.6 \times 16.5')$$

$$= 3060.1 - 2754.9 \rightarrow \frac{3060.1}{2754.9} = 1.11$$

∴ Multiply B1 & B2 by 1.11 for moment equilibrium

SB $S_{A36} = \frac{9.54 \times 8 \times 12}{24} = 38.2 \text{ in}^3$ use HP10x42

Ties $B1_{20'} = \frac{9.31 \times 1.11 \times 16}{0.94} = 175.9 \text{ k}$ use 5-0.6" strands every 2 SB

$B2_{20'} = \frac{7.32 \times 1.11 \times 16}{0.94} = 138.3 \text{ k}$ use 4-0.6" strands every 2 SB

Schnabel

FOUNDATION COMPANY

Calculation Sheets

Project Permanent Anchored Wall - Correction of Slide #2
 Location KY 227, Carroll Co., KY
 Architect/Engineer KDOT
 General Contractor _____

Contract No. _____
 Sheet No. 7
 Date 10/2/83
 By TCA

1 2 3 4 5 6 7 8 9 10 11 12 13 14 15 16 17 18 19 20 21 22 23 24 25 26 27 28 29 30 31 32

17.5' Slide Depth - SB# 7-8 and 73-90

$$p = 0.0528 \times 17.5' = 0.924 \text{ k}$$

$$\text{total force} = 0.924 \times 17.5' = 16.17 \text{ k}$$

SB @ 8' o.c.

$$H = 17.5', H1 = 4', H2 = 6.5'$$

$$B1 = 7.84 \text{ k/lf}$$

$$M1 = M2 = 7.39 \text{ k-ft/lf}$$

$$B2 = 5.10 \text{ k/lf}$$

check moment equilibrium about toe of SB:

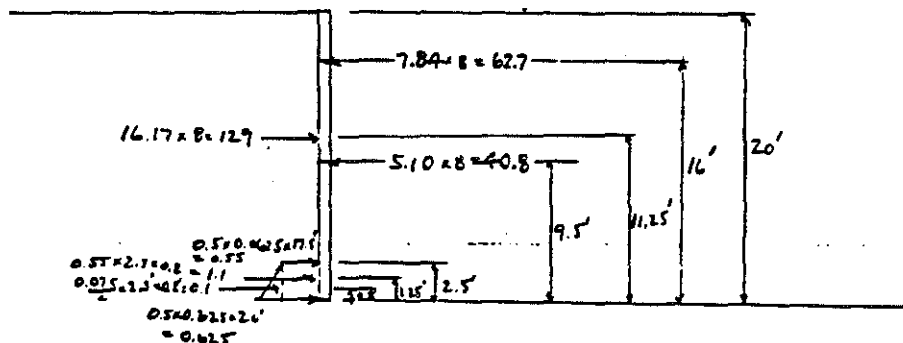

pile width
= 10" or 0.8

$$\Sigma M = 12.9 \times 11.25' + 1.1 \times 1.25' - 0.1 \times 0.8 - (62.8 \times 16.0' + 40.8 \times 9.5')$$

$$= 1452.7 - 1392.4 \rightarrow \frac{1452.7}{1392.4} = 1.043$$

∴ Multiply B1 & B2 by 1.043 for moment equilibrium

SB $S_{A36} = \frac{7.39 \times 8 \times 12}{(24)} = 29.6 \text{ in}^3$ Use HP10x42

Ties $B1_{20'} = \frac{7.84 \times 1.043 \times 16}{0.94} = 139 \text{ k}$ Use 4 - 0.6" strands every 2 SB

$B2_{20'} = \frac{5.10 \times 1.043 \times 16}{0.94} = 90.5 \text{ k}$ Use 3 - 0.6" strands every 2 SB

$B1_{30'} = \frac{7.84 \times 1.043 \times 16}{0.866} = 151 \text{ k}$ Use 5 - 0.6" strands every 2 SB

Project Permanent Anchored Wall - Correction of Slide #2
 Location KY 227, Carroll Co., KY
 Architect/Engineer KDOT
 General Contractor _____

Contract No. _____
 Sheet No. 8
 Date 10/6/53
 By TCA

1 2 3 4 5 6 7 8 9 10 11 12 13 14 15 16 17 18 19 20 21 22 23 24 25 26 27 28 29 30 31

15' Slide Depth - SB#91-98

$$P = 0.0528 \times 15' = 0.792 \text{ ksf}$$

$$\text{total force} = 0.792 \times 15' = 11.88 \text{ k/LF}$$

SB @ 8' o.c.

$$H = 15', H_1 = 4', H_2 = 5.5'$$

$$B_1 = 6.50 \text{ k/LF} \quad M_1 = M_{M2} = 6.34 \text{ k-Ft/LF}$$

$$B_2 = 3.20 \text{ k/LF}$$

check moment equilibrium about toe of SB

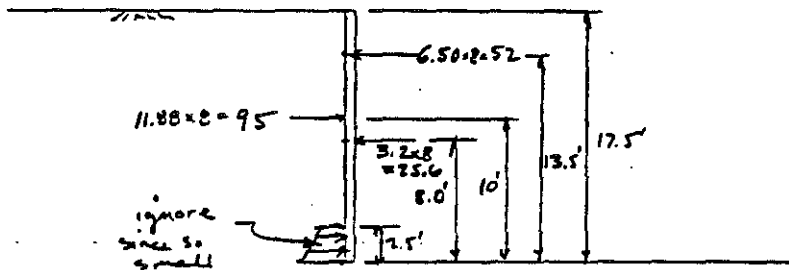

$$\Sigma M = 95 \times 10 - (52 \times 13.5 + 25.6 \times 8.0)$$

$$= 950 - 906.8 \rightarrow 950/906.8 = 1.05$$

∴ Multiply B_1 & B_2 by 1.05 for moment equilibrium

SB $S_{A36} = 6.34 \times 8 \times 12 / 24 = 25.4 \text{ in.}^3$

USE HP 10x42

Ties $B_{120} = \frac{6.50 \times 1.05 \times 16}{0.94} = 116 \text{ k}$

use 4-0.6" strands every 25'

$$B_{220} = \frac{3.20 \times 1.05 \times 16}{0.94} = 57 \text{ k}$$

use 2-0.6" strands every 25'

Project Permanent Anchored Wall - Correction of Slide #2 Contract No. _____
 Location KY 227, Carroll Co., KY Sheet No. 9
 Architect/Engineer KDOT Date 10/6/83
 General Contractor _____ By TCK

1 2 3 4 5 6 7 8 9 10 11 12 13 14 15 16 17 18 19 20 21 22 23 24 25 26 27 28 29 30 31 32

13.5' Slide Depth - SB # 5-6 and 99-120

$$p = 0.0528 \times 13.5' = 0.713 \text{ ksf}$$

$$\text{total force} = 0.713 \times 13.5' = 9.63$$

SB @ 8' OC.

$$H = 13.5', H1 = 6.75'$$

$$B1 = 9.63 \text{ k/LF} \quad M1 = 16.24 \text{ k-Ft/LF}$$

By inspection, B1 and total landslide force are equal in magnitude and in moment equilibrium about toe of SB.

SB $S_{A36} = \frac{16.24 \times 8 \times 12}{24} = 65.0 \text{ in}^3$

use HP12x53

Tie $B1_{20'} = \frac{9.63 \times 16}{0.94} = 164 \text{ k}$

use 5-0.6" strands every 2 SB

$$B1_{28'} = \frac{9.63 \times 16}{0.883} = 174.5 \text{ k}$$

use 5-0.6" strands every 2 SB

10' Slide Depth - SB # 3-4 and 121-124

$$p = 0.0528 \times 10' = 0.528 \text{ ksf}$$

$$\text{total force} = 0.528 \times 10' = 5.28 \text{ k/L}$$

SB @ 8' OC.

$$H = 10', H1 = 5'$$

$$B1 = 5.28 \text{ k/LF} \quad M1 = 6.6 \text{ k-Ft/LF}$$

By inspection, B1 and total landslide force are equal in magnitude and in moment equilibrium about toe of SB.

SB $S_{A36} = \frac{6.6 \times 8 \times 12}{24} = 26.4 \text{ in}^3$

use HP10x42

Tie $B1_{20'} = \frac{5.28 \times 16}{0.94} = 90 \text{ k}$

use 3-0.6" strands every 2 SB

$$B1_{30'} = \frac{5.28 \times 16}{0.866} = 98 \text{ k}$$

use 3-0.6" strands every 2 SB

Schnabel

FOUNDATION COMPANY

Calculation Sheets

Project Permanent Anchored Wall - Correction of Slide #2

Contract No. _____

Location KY 227, Carroll Co., KY

Sheet No. 10

Architect/Engineer KDOT

Date 10/6/83

General Contractor _____

By TCA

1 2 3 4 5 6 7 8 9 10 11 12 13 14 15 16 17 18 19 20 21 22 23 24 25 26 27 28 29 30 31 32

Wale Design

SB# 9-22 Upper

$$\text{Max. Tie Load, } P = 156 \text{ k}$$

$$M = Pa = 156 \times 1' = 156 \text{ k-ft.}$$

$$S_{V50} = \frac{156 \times 12}{30} = 62.4 \text{ in}^3$$

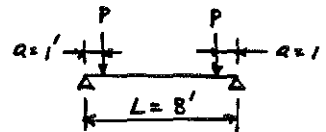

Use 2 C15 x 33.9 (V50)

SB# 9-22 lower

$$\text{Max. Tie Load, } P = 122 \text{ k}$$

$$M = Pa = 122 \times 1' = 122 \text{ k-ft.}$$

$$S_{V50} = \frac{122 \times 12}{30} = 44.8 \text{ in}^3$$

Use 2 C12 x 25 (V50)

SB# 5-6, 23-72 upper and 99-120

$$\text{Max. Tie Load, } P = 175.9 \text{ k}$$

$$M = PL/4 = 175.9 \times 8/4 = 351.8 \text{ k-ft.}$$

$$S_{V50} = \frac{351.8 \times 12}{30} = 140.7 \text{ in}^3$$

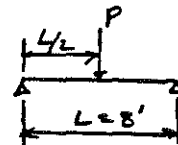

Use 2 MC18 x 51.9 (V50)

SB# 7-8 upper, 23-72 lower, 73-90 upper

$$\text{Max. Tie Load} = 151 \text{ k}$$

$$M = PL/4 = 151 \times 8/4 = 302 \text{ k-ft.}$$

Schnabel

FOUNDATION COMPANY

Calculation Sheets

Project Permanent Anchored Wall-Correction of Slide #2
Location KY 227, Carroll Co., KY
Architect/Engineer KDOT
General Contractor _____

Contract No. _____
Sheet No. 11
Date 10/6/83
By TCA

1 2 3 4 5 6 7 8 9 10 11 12 13 14 15 16 17 18 19 20 21 22 23 24 25 26 27 28 29 30 31 32

$$S_{v50} = \frac{302 \times 12}{30} = 120.8 \text{ in}^3 \quad \text{use } 2 \text{ MC } 18 \times 42.7 \text{ (v50)}$$

SB # 91-98 upper

$$\text{Max. Tie Load} = 116 \text{ K}$$

$$M = PL/4 = 116 \times 8/4 = 232 \text{ K-ft}$$

$$S_{v50} = \frac{232 \times 12}{30} = 92.8 \text{ in}^3 \quad \text{use } 2 \text{ C } 15 \times 40 \text{ (v50)}$$

SB # 3-4, 7-8 lower, 73-90 lower, 121-124

$$\text{Max. Tie Load} = 98 \text{ K}$$

$$M = PL/4 = 98 \times 8/4 = 196 \text{ K-ft}$$

$$S_{v50} = \frac{196 \times 12}{30} = 78.4 \text{ in}^3 \quad \text{use } 2 \text{ C } 15 \times 33.9 \text{ (v50)}$$

SB # 91-98 lower

$$\text{Max. Tie Load} = 57 \text{ K}$$

$$M = PL/4 = 57 \times 8/4 = 114 \text{ K-ft}$$

$$S_{v50} = \frac{114 \times 12}{30} = 45.6 \text{ in}^3 \quad \text{use } 2 \text{ C } 12 \times 25 \text{ (v50)}$$

Project Permanent Anchored Wall - Correction of Slide #2
 : on KY 227, Carroll Co., KY
 Architect/Engineer KDOT
 General Contractor _____

Contract No. _____
 Sheet No. 12
 Date 10/6/83
 By TCA

1 2 3 4 5 6 7 8 9 10 11 12 13 14 15 16 17 18 19 20 21 22 23 24 25 26 27 28 29 30 31 32

Lagging Design

Consider only the most critical condition for the 25' slide depth:

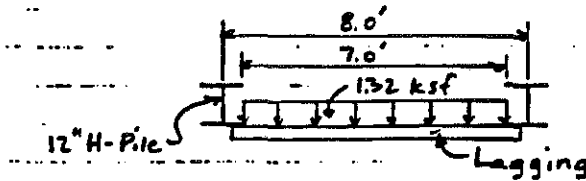

$$M_{max} = \frac{3}{8} (1/8) (1.32) (7.0)^2$$

$$= 5.39 \text{ k-ft or } 64.7 \text{ k-in.}$$

use Southern Pine - Dense Select Structural Grade

$$F_b = 2100 \text{ psi or } 2.1 \text{ ksi for } 2" \text{ to } 4" \text{ thick, } 6" \text{ and wider}$$

Short term Condition

$$\text{Increase uniform loading by } 1.33 \rightarrow M_{max} = 1.33 \times 64.7$$

$$= 86.02 \text{ k-in.}$$

$$\text{Increase } F_b \text{ by } 33\% \rightarrow F_b = 1.33 \times 2.10 = 2.8 \text{ ksi}$$

$$S_{req'd} = 86.02 / 2.8 = 30.72 \text{ in}^3$$

$$S = \frac{1}{6} (12) t^2 = 30.72 \rightarrow t = \sqrt{\frac{30.72 \times 6}{12}} = 3.9 \text{ in.}$$

Long term Condition

$$\text{Decrease } F_b \text{ by } 10\% \rightarrow F_b = 0.9 \times 2.1 = 1.9 \text{ ksi}$$

$$S_{req'd} = 64.7 / 1.9 = 34.05 \text{ in}^3$$

$$S = \frac{1}{6} (12) t^2 = 34.05 \rightarrow t = \sqrt{\frac{34.05 \times 6}{12}} = 4.1 \text{ in.}$$

∴ use 4" min. thick lagging (Southern Pine - Dense Select Structural)