

Research Report
KTC-94-20

EVALUATION OF PAVEMENT EDGE DRAINS
AND THE EFFECT ON
PAVEMENT PERFORMANCE

by

L. John Fleckenstein
Engineering Geologist

David L. Allen
Chief Research Engineer

and

Jack A. Harison
Research Engineer

Kentucky Transportation Center
College of Engineering
University of Kentucky
Lexington, Kentucky

in cooperation with
Transportation Cabinet
Commonwealth of Kentucky

and

Federal Highway Administration
U.S. Department of Transportation

The contents of this report reflect the views of the authors who are responsible for the facts and accuracy of the data presented herein. The contents do not necessarily reflect the official views or policies of the University of Kentucky, the Kentucky Transportation Cabinet, nor the Federal Highway Administration. This report does not constitute a standard, specification, or regulation. The inclusion of manufacturer names and trade names are for identification purposes and are not to be considered as endorsements.

September 1994

1. Report No. KTC-94-20		2. Government Accession No.		3. Recipient's Catalog No.	
4. Title and Subtitle Evaluation of Pavement Edge Drains and the Effect on Pavement Performance				5. Report Date September 1994	
				6. Performing Organization Code	
7. Author(s) L. J. Fleckenstein, David L. Allen, and Jack A. Harison				8. Performing Organization Report No.6 KTC-94-20	
9. Performing Organization Name and Address Kentucky Transportation Center College of Engineering University of Kentucky Lexington, KY 40506-0043				10. Work Unit No. (TRAIS)	
				11. Contract or Grant No.	
				13. Type of Report and Period Covered Interim	
12. Sponsoring Agency Name and Address Kentucky Transportation Cabinet State Office Building Frankfort, KY 40622				14. Sponsoring Agency Code	
15. Supplementary Notes Publication of this report was sponsored by the Kentucky Transportation Cabinet with the U.S. Department of Transportation, Federal Highway Administration					
16. Abstract This report documents the performance of highway edge drains in Kentucky. Approximately eighteen highway edge drain installations were inspected. The report also documents the laboratory testing, construction, short-term and long-term performance of these systems. Construction inspection and maintenance are addressed. It is apparent that the panels are distressed more under the old method of installation using excavated trench material and dynamic type compaction. It is apparent that using the sand slurry reduces the chances of installation damage. Proper density needs to be achieved during installation of the sand backfill or damage will occur due to trench settlement. In most cases, increasing the density of the sand increased the performance of the panel drain. It is apparent through the field analysis that the maintenance and construction of the edge drain systems need to be improved. Field inspections of the headwalls and outlets indicates that approximately 25 percent of the outlets are not properly installed, and that the headwalls are not properly maintained. Inspection data indicate that approximately 45 percent of the outlets are partially covered to completely plugged. The center of mass is also located in the rear of the headwall causing the headwall to tilt backwards over time. Soil moisture and thermography data indicate that edge drains help move water laterally across the pavement structure, and that the shoulder acts as a restraining dam for pavements without edge drains. The gradation analysis performed on the sand backfill from the current edge drain installation specification showed that the sand backfill effectively filters out some of the minus 200 material. Blinding of the sand at this time does not appear to be a problem. Although further testing is needed, preliminary data indicates the sand acts as a filter by not allowing the fines from the broken concrete to flush into the filter fabric immediately after construction. FWD data indicate that edge drains significantly increase the strength of the subgrade by removing water. Preliminary analyses of Ride index data indicates that the edge drains may add significant life to the pavement structure. These conclusions are based on data from edge drain systems that are not fully functional.					
17. Key Words Edge Drain Density Settlement			18. Distribution Statement Borescope Siltation Performance Unlimited		
19. Security Classif. (of this report) Unclassified		20. Security Classif. (of this page) Unclassified		21. No. of Pages 109	22. Price



EXECUTIVE SUMMARY

This report documents the performance of pavement edge drains in Kentucky. Approximately eighteen pavement edge drain installations were inspected. The report also documents the construction, short-term and long-term performance of these systems. Construction inspection and maintenance are addressed.

It is apparent through the field analysis that the maintenance and construction of the panel and pipe edge drain systems need to be improved. Field inspections of the headwalls and outlets indicate that approximately 25 percent of the outlets are not properly installed, and that the headwalls are not properly maintained. Inspection data indicates that approximately 45 percent of the outlets are partially covered to completely plugged.

It is apparent that the panel edge drains are distressed more under the old method of installation using excavated trench material and dynamic type compaction. It is apparent that using the sand slurry reduces the chances of installation damage. Proper density needs to be achieved during installation of the sand backfill or damage will occur due to trench settlement. In most cases, increasing the density of the sand increased the performance of the panel edge drain.

It is apparent that vertical compression can occur in round pipe edge drains when sand is not properly densified and construction traffic is allowed to travel over the trench.

Soil moisture and thermography data indicate that panel and pipe edge drains help move water laterally across the pavement structure, and that the shoulder acts as a restraining dam for pavements without edge drains.

The gradation analysis performed on the sand backfill from the current panel and pipe edge drain installation specification showed that the sand backfill effectively filters out some of the minus 200 material. Blinding of the sand at this time does not appear to be a problem. Although further testing is needed, preliminary data indicates the sand acts as a filter by not allowing the fines from the broken concrete to flush into the filter fabric immediately after construction.

FWD data indicate that panel and pipe edge drains significantly increase the strength of the subgrade by removing water.

Preliminary analyses of Ride index data indicate that panel and pipe edge drains may add significant life to the pavement structure. These conclusions are based on data from edge drain systems that are not fully functional.

A laboratory procedure for testing panel edge drains under vertical load was developed under this study. The test was developed to try to simulated field conditions. Six different panels were tested (Akwadrain, Contech, Prodrain, Hydraway, Advanedge, and Supac). Information obtained from these tests indicates

that the ADS panel performed the best of the six panels tested. The more solid type cores (ADS and Supac) had the least amount of core reduction. Hydraway and Supac drains were the most susceptible to vertical compression when the sand was loose. The Hydraway core was also the most susceptible to reduction in core capacity when the sand was loose. The more open cores (Akwadrain, Contech, Prodrain, and Hydraway) are prone to loss of core capacity due to the top rows of support columns rolling over and the rigid backing folding and compressing. In all cases, the more open cores (Akwadrain, Contech, Prodrain, and Hydraway) performed substantially better when the more open side was placed against the wall of the chamber. The Akwadrain core showed the least amount of distress of these types, probably due to its chemical composition (PVC).

To date, the maximum horizontal pressure measured in the field was 61 kPa (8.85 psi). It is the opinion of the authors that this was measured under extreme conditions and that actual installation pressures are probably less.

Further field monitoring is necessary to confirm the maximum load needed for laboratory testing and panel and pipe edge drain design.

TABLE OF CONTENTS

1.0 INTRODUCTION	1
2.0 BACKGROUND	2
2.1 Research by Others	2
2.2 Installation and Maintenance Problems	4
2.2.1 Installation Problems with Panel Drains	4
2.2.2 Outlet Pipe and Headwall Problems	4
2.2.3 Headwall Distances	5
2.3 Modifications in Design and Construction	6
2.3.1 New Installation Method	6
2.3.2 Modification in Headwall Distances	6
2.3.3 Modifications in Outlet Pipe	6
3.0 ANALYSIS OF CONSTRUCTION AND MAINTENANCE FACTORS AFFECTING EDGE DRAINS	7
3.1 Evaluation of Construction Factors	7
3.1.1 Mountain Parkway	7
3.1.2 Interstate 75	8
3.1.3 Interstate 64	10
3.1.4 Interstate 65	10
3.1.5 Bluegrass Parkway	11
3.1.6 Western Kentucky Parkway	13
3.1.7 Interstate 24	14
3.1.8 Pennyrile Parkway	15
3.1.9 Summary of Construction Factors	16
3.2 Evaluation of Maintenance Factors	16
3.2.1 Summary of Maintenance Factors	17
4.0 DEVELOPMENT OF GENERIC SPECIFICATION FOR HIGHWAY EDGE DRAIN - PANEL TYPE	17
4.1 Laboratory Evaluations Conducted in this Study	17
4.1.1 Vertical Edge Drain Compression Chamber	18
4.1.2 Method of Testing	18
4.1.3 Testing Series	19
4.1.3.1 Results of Series 1	19
4.1.3.2 Results of Series 2	19
4.1.3.3 Results of Series 3	20
4.1.3.4 Results of Series 4	21
4.1.3.5 Summary of Vertical Compression Tests	21
4.2 Comparison of Laboratory Test Methods	22
4.2.1 Flat Parallel Plate Test	22

4.2.2 Eccentric Loading	22
4.2.3 Vertical Compression Test	22
4.3 Horizontal Stress Analysis	22
4.3.1 Horizontal Stress (Finite Element Modeling)	22
4.3.2 Horizontal Stress (Measured in Laboratory)	23
4.3.3 Horizontal Stress (Field Measurements)	23
4.4 Correlation of Laboratory Tests with Field Performance	24
4.5 Performance of Edge Drain Backfill and Fabrics	24
4.6 Generic Specification	26
5.0 LATERAL EFFECTIVENESS OF EDGE DRAIN SYSTEMS	27
5.1 Subgrade Moisture	27
5.2 Thermographic Inspection of Pavement Surface	28
6.0 EFFECTS OF EDGE DRAINS ON PAVEMENT PERFORMANCE	29
6.1 FWD Tests	29
6.2 Change in Ride Quality	30
7.0 COST EFFECTIVENESS OF EDGE DRAINS	31
8.0 CONCLUSIONS	32
9.0 RECOMMENDATIONS	34
APPENDIX	84

LIST OF FIGURES

- Figure 1. Edge Drain Compression Chamber
- Figure 2. Top View of Compression Chamber
- Figure 3. Profile of Edge Drains Tested
- Figure 4. Vertical Compression (Series 1-4)
- Figure 5. Change in Core Capacity (Series 1-4)
- Figure 6. Core Capacity (Series 1-4)
- Figure 7. Flat Parallel Plate Test

- Figure 8. Finite Element Modeling Stressed Introduced at Panel
- Figure 9. Backfill Gradation, Mountain Parkway (% Passing No. 60 Sieve)
- Figure 10. Backfill Gradation, Mountain Parkway (% Passing No. 200 Sieve)
- Figure 11. Backfill Gradation, Bluegrass Parkway (MP 57)
- Figure 12. Backfill Gradation, Bluegrass Parkway (MP 34)
- Figure 13. Backfill Gradation, Interstate 75 (MP 122.9)
- Figure 14. Filter Fabric around ADS Panel (Backfilled with Sand)
- Figure 15. Filter Fabric around ADS Panel (Backfill with Excavated Material)
- Figure 16. Electron Microscope Scan of Sediments
- Figure 17. Filter Fabric From I-75 and I-64 Interchange (Tack Coat on Fabric)
- Figure 18. Filter Fabric From I-75 and I-64 Interchange (Clogged Fabric)
- Figure 19. Sieve Analysis of Aggregate From I-64 and I-75 Interchange
- Figure 20. Normalized Subgrade Moisture
- Figure 21. Modified Normalized Subgrade Moisture
- Figure 22. Thermographic Inspection of Bluegrass Parkway (MP 36.0)
- Figure 23. Thermographic Inspection of Bluegrass Parkway (MP 34.4)
- Figure 24. Normalized Pavement Moisture using Nuclear Density Gage
- Figure 25. Subgrade Modulus of Before Edge Drains and After
- Figure 26. Subgrade Modulus of Pavement with Edge Drains and without
(Bluegrass Parkway, Milepost 58.4 to Milepost 59.5)
- Figure 27. Subgrade Modulus of Pavement with Edge Drains and without
(Bluegrass Parkway, Milepost 56.4 to Milepost 57.4)
- Figure 28. Subgrade Modulus of Pavement with Edge Drains and without
(Bluegrass Parkway, Milepost 57.4 to Milepost 58.4)
- Figure 29. Change in Normalized RI as a Function of Accumulated ADT'S
(Interstate 75, Whitley County)

- Figure 30. Change in Normalized RI as a Function of Accumulated ADT'S
(Interstate 75, Laurel County)
- Figure 31. Change in Normalized RI as a Function of Accumulated ADT'S
(Interstate 75, Fayette County)
- Figure 32. Change in Normalized RI as a Function of Accumulated ADT'S
(Interstate 64, Jefferson County)
- Figure 33. Change in Normalized RI as a Function of Accumulated ADT'S
(Interstate 64, Franklin County)
- Figure 34. Change in Normalized RI as a Function of Accumulated ADT'S
(Interstate 64, Fayette County)
- Figure 35. Change in Normalized RI as a Function of Accumulated ADT'S
(Interstate 264, Milepost 0.48 to Milepost 1.89)
- Figure 36. Change in Normalized RI as a Function of Accumulated ADT'S
(Interstate 264, Milepost 0.48 to Milepost 1.89)
- Figure 37. Change in Normalized RI as a Function of Accumulated ADT'S
(Interstate 264, Milepost 2.86 to Milepost 3.78)
- Figure 38. Change in Normalized RI as a Function of Accumulated ADT'S
(Interstate 24, Milepost 65.35 to Milepost 76.07)
- Figure 39. Change in Normalized RI as a Function of Accumulated ADT'S
(Interstate 24, Milepost 76.07 to Milepost 85.56)
- Figure 40. Change in Normalized RI as a Function of Accumulated ADT'S
(Interstate 24, Milepost 85.56 to Milepost 93.39)
- Figure 41. Change in Normalized RI as a Function of Accumulated ADT'S
- Figure 42. Extended Pavement Life as a Function of RI (when edge drains installed)

LIST OF TABLES

- Table 1. Percent Vertical Compression At 156.5 kPa
- Table 2. Change in Core Capacity (Open Side of Panel Facing Sand)
- Table 3. Core Capacity in Square Inches at 0 kPa and 156.5 kPa
- Table 4. Change in Core Capacity (Rigid Back Side of Panel Facing Sand)



Table 5. Headwall Inspection, Mountain Parkway

Table 6. Headwall Inspection, Interstate 64

Table 7. Headwall Inspection, Interstate 75

Table 8. Headwall Inspection (Average of Mountain Parkway, I-64 and I-75)

Table 9. Summary of FWD Test Results from Bluegrass Parkway (MP 56.4-59.4)

Table 10. Predicted Increase in Pavement Life of Pavements with Edge Drains

Table 11. Predicted Cost Savings using Edge Drains

1.0 INTRODUCTION

Pavement surface drainage has been an important factor in road design since the 1930's. Over the past 20 years, transportation agencies have come to realize that not only surface drainage is important but also subsurface drainage is essential to maintaining the design service life of the nation's highways. Early subsurface drainage systems were constructed by cutting a trench and backfilling it with a free draining aggregate, and providing an outlet for water to exit the system. Round perforated pipe was later placed in the porous backfill which increased the discharge rate of the system. Panel edge drains were introduced during the mid 1980's.

The purpose of these systems is to collect and remove water within and under the pavement structure. Pavement edge drains are designed to collect water from construction joints, expansion joints in PCC pavements, porous AC layers, porous base layers, broken concrete layers, and the subgrade.

Past history of pavement edge drains indicates that (if properly designed and installed) they will reduce stripping in AC Pavements and reduce pumping at the joints of PCC Pavements. The removal of water from voids in the AC Pavements and joints in PCC Pavements reduces the water at the surface of the structure thus reducing the potential for hydroplaning. The pavement edge drains also remove water from the subgrade which can have a positive effect on the strength of the subgrade and the life of the pavement.

The State of Kentucky has been installing round pipe pavement edge drains since the mid 70's and panel edge drains since 1985. In the past eight years, considerable effort has been expended in observing these materials and their behavior in the field.

This study was initiated to attempt to determine the effectiveness of these pavement edge drains. The general objectives are as follows:

- (1) To quantify the major in-service problems of pavement edge drains and their outlets, such as blinding of fabric or clogging of panel cores or clogging of the round pipe, and evaluate past and current construction practices,
- (2) To develop a generic specification for pavement edge drains,
- (3) To determine the lateral effectiveness of pavement edge drains across the pavement structure,
- (4) To verify that pavement edge drains improve pavement performance, and
- (5) To determine the cost effectiveness of pavement edge drains.

2.0 BACKGROUND

2.1 Research by Others

Jeffcoat et.al. (1) of the US Geological Survey have reported on a research effort to study the effectiveness of highway edge drains. Highway sites in ten States were instrumented where edge drains had been retrofitted. Instrumentation was included to measure the amount of rainfall, edge drain discharge, piezometric water levels, and soil moisture under the pavement as well as the adjacent shoulder.

The authors indicated that all pavements will ultimately suffer joint damage and water infiltration into the subgrade. Because of the initial tightness of the subgrade, water will flow into upgrade joints and discharge downgrade at other joints, eroding fines from the subbase. Ultimately, voids and channels form to drain off excess infiltration water. At times, sections of pavement may be literally sitting in a shallow basin of water.

The authors indicated that in many instances the outside shoulders of the highway form a restraining dam to transverse subgrade drainage. Retrofitting an edge drain along the pavement edge with outlet pipes through the shoulders serves to short circuit the shoulders. A major component of the edge drain discharge is the surface flow off the pavement which enters the longitudinal edge drain directly.

Retrofitting longitudinal edge drains to an existing highway provides a sink to collect water draining laterally off the pavement surface as well as water reaching the edge drain through subgrade voids and channels. The authors indicated most of the lateral subgrade water movement is via voids and channels that develop under the pavements.

They further implied that the use of a permeable subgrade along with the use of edge drains should be the most efficient means in restoring the highway.

Results of research conducted by Elsharief (2) indicated two primary areas of edge drain construction and performance that need attention. The first was the effect of installation and field loading on the flow capacity of the drain, and the second was the performance of the geotextile filter.

In this same study, field excavations were conducted evaluating the performance of one brand of edge drain which had been installed in the mid 1980's. A total of five sites were inspected, and structural damage was observed at three sites. Severe structural damage was observed at one location. Heavy siltation was observed at one location. Several of the outlets were covered with grass and/or soil.

Morphological evaluation of field geotextile samples showed partial clogging of the geotextile. The edge of the geotextiles did not appear to affect their long-term performance as filters. Soil particles were found trapped in the geotextiles at locations of dense fabrics.

Elsharief concluded a panel drain should have a minimum flow capacity of 15-18 gallons/minute/foot for longitudinal drain slopes of 2% and 1%, respectively, (ASTM-D4716-87) to perform as well or better than a conventional round pipe edge drain, when draining dense subbases.

A minimum normal compressive strength of 8,100 pounds per square foot (psf) and an inclined compressive strength of 7,500 psf at 80 degrees inclination was recommended.

Research by Froble (3) has concluded the conical cusped and solid oblong flat pipe cores were relatively stable under angled loading whereas the double cusped and the high profile column type cores were prone to collapse. Froble highlighted the significant differences in load deflection properties of the different panel types in comparing flat parallel plate tests versus eccentric loading tests.

Research published by Stuart (4) concluded that two possible conditions can affect the geocomposite's ability to transmit water. These are compression or crushing of the core, and stretching and filling of the passageways in the core by the geotextile. Results of their tests showed that as the confining pressure increases, the flow decreases. Visual evaluations of the samples after the tests showed both core compression and geotextile stretch occurred to some extent in most of the specimens.

Research by Young (5) indicated that deformities in the geocomposite core and tears in the fabric are experienced during installation if good compaction practices are not followed. Settlement of the backfill is likely to occur even with good compaction. Large slab movements can cause holes to develop in the geotextile of the fin drain when in contact with the PCC pavement.

Young's research conducted on I-475 showed an increase in deformation in the section of pavement with fin drains. It appears the fin drain accelerated the removal of fines from the base/subbase. The base/subbase materials used in Georgia on older PCC pavements have a high percentage of fines (approximately 24% percent passing the No. 200 sieve).

2.2 Installation and Maintenance Problems in Kentucky (from Previous Studies)

2.2.1 Installation Problems with Panel Drains

Kentucky has been evaluating panel edge drains since 1985. Several edge drain failures occurred in earlier installations. The majority of the earlier panel drains, were placed next to the concrete pavement and backfilled with the excavated trench material which was dynamically compacted. The dynamic compaction (vibratory tamping skid or shoe) tended to collapse the core of the edge drains. Several projects having numerous miles of edge drains were installed in this manner throughout the State.

2.2.2 Outlet Pipe and Headwall Problems

Failures also have been observed in the single-wall outlet pipes. In 1989, 4-inch flexible outlet pipes in Powell County on the Mountain Parkway were inspected with a Cues Mini Camera. The headwalls were inspected randomly at approximately half-mile intervals. A total of fifteen outlets were inspected on the eastbound side of the Parkway, and 11 of the 15 had been damaged by guardrail posts.

In 1991, headwalls and outlets were evaluated on Interstate 75 from Lexington, Kentucky to Cincinnati, Ohio (approximately 112 km (70 miles)) and on Interstate 71 from Louisville, Kentucky to Interstate 75 in Northern Kentucky (approximately 109 km (68 miles)). One headwall and one outlet per mile were inspected.

A total of 122 headwalls and outlets were inspected on Interstate 75. Of the 122 headwalls inspected, 35 percent were clean (no debris in the trough of the headwall), 41 percent were partially covered (outlet was partially visible), 9 percent were covered (outlet pipe not visible), and 15 percent were plugged (outlet pipe was completely filled with debris).

A total of 127 headwalls and outlets were inspected on Interstate 71. Of the 127 headwalls, 43 percent were clean, 30 percent were partially covered, five percent were covered, and 22 percent were plugged. Averages for Interstate 75 and Interstate 71 were as follows: 39 percent were open, 36 percent were partially covered, 7 percent were covered, and 18 percent were plugged.

The rodent screens were inspected for signs of clogging and rusting. Averages for Interstate 71 and Interstate 75 indicated that 28 percent of the headwalls did not have screens, 42 percent of the screens were open, 15 percent were partially blocked,

15 percent were blocked, and 34 percent were severely rusted. The galvanized screens now specified have aided in preventing corrosion.

Each outlet was inspected for signs of flow and to determine if positive drainage had been provided. On the average for both routes, 89 percent of the headwalls showed flow and 74 percent of the headwalls had been provided with a proper grade to drain water away from the headwalls. Approximately 27 percent of the outlets on Interstate 75 were not properly drained.

A total of 249 outlet pipes were inspected on Interstate 71 and Interstate 75. The pipes were inspected for sags, siltation, standing water, compression, rips, and other noticeable distress. Approximately 35 percent of the outlet pipes that were inspected were fully open, 16 percent were 60 to 80 percent open, 14 percent were 40 to 60 percent open, and 35 percent were less than 40 percent open. Approximately 50 percent of the outlet pipes had failed in compression.

Distress information indicates that for Interstate 75 there were more significant problems occurring at the connection between the headwall and the outlet pipe than any other area in the system. More significant distress occurred on Interstate 71 between the headwall and the asphalt shoulder than any other area in the outlet system. It appears that more significant problems have occurred at the connection between the headwall and the outlet pipe. It also appears that pipes are better backfilled in the mainline than for the outlet pipes.

The outlet was considered fully in service if the headwall was clean and the outlet pipe was greater than 60 percent open. The outlet was considered partially open if the headwall was partially covered and/or the outlet was 40 percent to 60 percent open. The outlet was considered out of service if the headwall was plugged and/or if the outlet pipe was less than 40 percent open.

On the average for both routes, 43 percent of the outlets were out of service, and 22 percent of the outlets were fully in service with the remainder being partially in service. Approximately 50 percent of the outlet pipes had been damaged during installation.

2.2.3 Headwall Distances

The distance between edge drain outlets was analyzed. In several cases the edge drain outlets were as much as 670 meter (2,200 feet) apart. Flow calculations, indicated that expected flow would be 18 times greater than the capacity of the edge drain (1).

2.3 Modifications In Design and Construction of Panel Edge Drains in Kentucky

Several modifications were made in the edge drain specification in 1989. This was in response to the numerous failures occurring in the edge drain systems. Modifications were made in the placement of the panel in the trench, backfill around the panel, headwall distances, and outlet pipe material.

2.3.1 New Installation Method

Panel edge drains have been installed on the shoulder side of the trench and backfilled with a sand slurry, since 1989. The sand is flushed into the trench using approximately 3.8 litres (one gallon) of water per 0.3 linear meter (linear foot) of edge drain. The sand slurry minimizes construction problems (if the sand is properly densified), and the sand serves as an extra filter medium. Hundreds of sites were examined with a borescope. In most cases, the edge drains installed with the sand slurry were performing better than installations installed under the old procedure.

2.3.2 Modification in Headwall Distances

The distance between edge drain outlets (panel and pipe edge drains) was modified to permit a maximum of 152 meter (500 feet) for panel edge drains installed on two percent grades or greater and on grades less than two percent, outlet headwalls are installed at a maximum of 76 meter (250 feet).

2.3.3 Modifications in Outlet Pipe

The outlet pipe was changed from a single-walled flexible pipe to a double-walled smooth-lined pipe (corrugated polyethylene, Type S, meeting AASHTO M 252). New rodent screens were required to be hot-dipped galvanized.

Performance of the new outlet pipes was evaluated in 1991. Outlet pipes were inspected in approximately 0.8 km (one-half mile) intervals in both directions of Interstate 64. A total of 68 outlet pipes was inspected. The outlet pipes were inspected for sags, siltation, standing water, compression, rips, and other noticeable distress. Approximately 69 percent of the outlet pipes was more than 90 percent open, 20 percent was 60 to 90 percent open, 4 percent was 40 to 60 percent open, and

approximately 6 percent was less than 40 percent open. Approximately 10 percent of the outlet pipes had been crushed significantly during installation.

The largest amount of stress that was observed in the 101 mm (4-inch) pipe occurred in the flexible pigtail which was precast into the headwall. The pigtail is approximately one to two feet long on the back side of the headwall. Approximately 70 percent of the outlet pipes had noticeable sags in this area. Significant compression had occurred in the flexible pigtail during installation. Approximately 34 percent of the outlet pipes had noticeable compression in the flexible pigtail. It was apparent that this was the weakest part of the outlet pipe system. Approximately 45 percent of the rigid outlet pipes had sags through the asphalt shoulder.

It appeared more distress was occurring in the outlet pipes that were connected to the median boxes than to the headwalls. Approximately 57 percent of the median outlets that was inspected was less than 60 percent open. More distress was observed in the eastbound shoulder headwalls than in the westbound shoulder headwalls.

3.0 ANALYSIS OF CONSTRUCTION AND MAINTENANCE FACTORS AFFECTING PAVEMENT EDGE DRAINS (OBJECTIVE NO. 1)

3.1 Evaluation of Construction Factors

To accomplish objective No. 1, a significant portion of this study was to evaluate current edge drain installations including construction and maintenance problems, and to evaluate long-term performance of these systems. Selected edge drain sites were chosen across the state to evaluate. Figure 1 contains the profile of the cores evaluated under this study. The results of the excavations are discussed in the following section.

3.1.1 Mountain Parkway

Two edge drain sites were excavated on the Mountain Parkway in September, 1991. The first site excavated was on the eastbound lanes on an entrance ramp at Milepost 22.2. The Type E edge drain panel had been in service for approximately 2.5 years. The edge drain was installed against the face of the concrete and backfilled with excavated trench material. The pavement had been broken and overlaid. Approximately four inches of precipitate were observed in the invert of the drain. The 101 mm (4-inch) outlet was inspected with a Cues Mini Camera. The drain had been partially compressed during construction. In addition, a buildup of precipitates was

partially blocking the screen. Some horizontal compression was observed in the support columns of the Type E panel drain. The bottom perforations in the core of the panel were partially blinded. It was apparent the large buildup of precipitates in the invert of the panel was due largely to the condition of the outlet.

A second site was excavated at Milepost 20 (westbound). The edge drain had been in service for approximately two years. The Type E edge drain panel had been installed on the backside of the trench and backfilled with a sand slurry. Approximately 50.8 mm (two inches) of material was observed in the invert of the panel. No vertical or horizontal distress was observed in the panel. The corresponding outlet was partially crushed causing the siltation in the panel. The sand and the geotextile (filter fabric) appeared to be clean. There were no visible signs of blinding of the sand or the geotextile.

The Type E edge drain was inspected in April 1994, at Milepost 19.9 in the westbound lane in a sag in a vertical curve. The sand backfill appeared to be relatively clean. The outlet pipe was not installed at the lowest point of the sag. The edge drain was inspected below the outlet, closer to the base of the sag. Slight horizontal compression was observed in the drain between support columns. Approximately 50.8 mm (two inches) of silty water was standing in the invert of the panel, and the panel was stained approximately one inch above the second row of support columns. Staining in the panel indicated the panel had been standing or running more than one half full of water. Water was pumped from a water tank into the edge drain to the height of the stain, at this level water was observed running out of the headwall. The outlet pipe was also crushed approx. 40% at the backside of the headwall.

3.1.2 Interstate 75

Ten miles of edge drains were installed on Interstate 75 in 1989. Nine miles of Type E drains were installed in the southbound outside shoulder from Milepost 101.32 to Milepost 110.25. Approximately one mile of a drain similar to Type B (Contech Stripdrain 100) was installed in the southbound, outside shoulder from Milepost 100.32 to Milepost 101.32. The edge drains had been installed on the shoulder side of the trench and backfilled with sand. Borescope observation ports were installed at every milepost. Both edge drain systems were borescoped after construction was completed in 1989. There were no signs of compression or siltation in either drainage system.

The edge drains were reinspected on the southbound side of Interstate 75 in June 1991. The Stripdrain 100 panel was excavated in two locations at Milepost 101.35 and Milepost 101.28. At both locations, the top two rows of support columns had rolled over. The fabric was pushed in between the support columns between rows five and six. At Milepost 100.51, the sixth row of support columns had punctured the

fabric allowing material to enter the core of the panel. Some of the support columns in row six had also failed. The panel was bowed out from the wall of the trench at both locations. The panel was bowed out from the shoulder side of the trench approximately 38.1 mm (1.5 inches). This indicates the panel may not have been correctly placed during installation. Less damage may have occurred if the panel had been flush with the wall of the trench. Approximately 85 percent of the core was still open. There were no signs of horizontal or vertical compression in the Type E panel which was inspected at Milepost 101.67 (southbound).

The asphalt patch had settled approximately 12.7 mm (1/2 inch). It appears this settlement may have caused the top two rows of the Stripdrain 100 to be pushed down. Further densification of the sand backfill may have also caused the filter fabric to be pushed in between rows five and six to the point the filter fabric and the support columns started to fail.

During the excavation of the trench, the sand backfill was inspected for signs of blinding or clogging. A distinct layer approximately 6.3 mm (1/4-inch) thick of dark silted sand was observed adjacent to the concrete interface. The remainder of the sand appeared to be clean. The filter fabric surrounding the core of the drain was also clean. Gradation tests were performed on the samples collected from the middle of the trench and adjacent to the concrete interface. Gradation analysis showed an increase on the 10, 20, and the -200 sieve adjacent to the concrete. The number 10 sieve had increase approximately 3 percent and the number 20 sieve had increased approximately 6 percent at the concrete interface. The number -200 material had increased approximately 2 to 3 percent against the concrete interface.

In April, 1994 pavement pumping was observed at Milepost 137.9 approximately 300 feet from a bridge end. The pavement was failing in both the inside and outside southbound lanes. The failure appeared to be concentrated in the left wheel path in the inside lane and the right wheel path in the outside lane. The failures were occurring adjacent to the inside and outside edge drain outlets. The southbound outside headwall was inspected. The outlet pipe had several sags in which large amounts of silt had been deposited. The southbound inside outlet was sagged behind the headwall and also contained a large amount of silt. The outlet pipe was approximately 50 to 60 percent crushed at approximately 1.5 meter (five feet) from the outlet. The northbound inside headwall was inspected. The outlet was severely compressed and blocked with silt behind the headwall. At the time of the inspection, no pavement distress was noticeable on the northbound side at the pavement surface.

In October 1993 and April 1994, pavement pumping was observed at Milepost 123.4, southbound on Interstate 75. This section of highway had 101 mm (4-inch) pipe drains. The staining was occurring in a sag in a vertical curve. Five edge drain outlets were investigated and found to be partially or fully crushed. At Milepost 122.9 the headwall and outlet were plugged with silt and grass. The outlet pipe was also crushed approximately four feet from the headwall. At Milepost 122.7, the outlet pipe was full of sediment. The headwall was below the grade of the surrounding area. At

Milepost 123.2, the outlet pipe was crushed on the backside of the headwall, and at Milepost 123.4 at the center of the sag the outlet pipe was completely crushed approximately 1.8 mm (six feet) from the headwall. At Milepost 123.6, the outlet pipe was completely crushed on the backside of the headwall. A trench was excavated down to the 101 mm (4-inch) pipe edge drain. Dams of precipitate were observed throughout the edge drain system. The pipe was 75 percent blocked in some areas.

3.1.3 Interstate 64

The Type D drain was inspected in October 1991. The final asphalt wedge had been placed at the time of the inspection,. The edge drain was inspected with the borescope at five different locations. The locations are listed below.

Milepost	Direction	Location
72.868	WB	Outside Shoulder
72.524	WB	Outside Shoulder
72.000	WB	Outside Shoulder
61.000	WB	Outside Shoulder
63.650	EB	Outside Shoulder

Similar types of distresses were apparent in all panels. All edge drains were bent (angled) at the 8th or 9th row of support columns. They were angled toward the inside of the trench (toward the pavement side of the trench). The rigid backing of the inner core had cracked on approximately one-half of the panels where they had been bent. The bottom of the panels had been bent or pushed out from the trench wall due to settlement and/or the application of wheel loads on the asphalt plug. The Type D panel is very flexible when folded toward the open side of the panel, but deformation results in the inner core when the rigid backing is folded in the opposite direction.

The edge drains were inspected in two locations in November 1993 in the vicinity of Milepost 63 (westbound). Approximately 25.4 mm (one inch) of trench settlement was observed in the second asphalt patch. The panel appeared to be clean and open at both locations. It was apparent that some vertical compression had occurred in the panel allowing the filter fabric to partially intrude into the core of the drain. Overall the drain appeared to be in fair condition.

3.1.4 Interstate 65

Two sites were excavated on Interstate 65 in September 1991 at approximately Milepost 5.7 and Milepost 5.8. Approximately 6.1 meter (20 feet) of Type D drain had

been excavated in 1990 which was almost entirely plugged with fines. The outlet was inspected in this area and found to be partially crushed. The edge drains had been installed under the old installation specification. The Type D panel was excavated at Milepost 5.7. The drain appeared to be "J'd" at the bottom. The rows of support columns had been forced down. It appears the drain had been partially crushed during installation.

The edge drain and its corresponding outlet were investigated at Milepost 5.8. The outlet appeared to be approximately 75 percent crushed. The panel drain was severely "J'd". It appears all the support columns had collapsed downward. The core of the drain was approximately 10 to 15 percent open.

3.1.5 Bluegrass Parkway

Considerable staining was observed at Milepost 39.3 and Milepost 40.0 (eastbound lane) in April 1992. Two outlets draining this area were inspected. One was draining the bridge end and the other appeared to be an outlet for the edge drain. The outlet for the edge drain was inspected. The outlet pipe was inspected with the Cues Mini Camera. The pipe was crushed approximately 2.1 meter (seven feet) from the headwall. The outlet was approximately 55 percent open.

The outlet at Milepost 40.0 on the westbound side of the parkway was inspected. Staining and failures were occurring approximately 609 meter (2000 feet) upgrade. The trough of the headwall was completely filled with rock and soil. The outlet pipe was also plugged with debris. Water was ponding around the headwall. The outlet pipe was partially crushed approximately 0.8 meter (2.5 feet) from the headwall. The pipe was approximately 60 percent open.

A trench was excavated down to the mainline consisting of 101 mm (4-inch) perforated pipe. The trench was approximately 6 meter (20 feet) upgrade from the outlet. Approximately 19 mm (0.75 inch) of precipitates had been deposited in the invert of the mainline. The sand backfill around the outlet appeared to be clean. It appeared the partially crushed outlet pipe and the plugged headwall were causing material to be deposited in the mainline of the edge drain.

An inspection hole was excavated at Milepost 40.5 on the westbound side of the parkway in April 1992. The trench was excavated below a failed area in the right wheel path. The failed area was approximately four feet wide and 4.5 meter (15 feet) long. It appeared this area had been patched several times. The sand backfill around the mainline was inspected. It appeared that some buildup of material was occurring at the sand-PCC interface. The pipe was standing 1/3 full of water and approximately 12.7 mm (1/2 inch) of precipitate was observed in the invert of the pipe.

A Cues Mini Camera was used to inspect the pipe downgrade from the

inspection hole. The water level rapidly dropped as the camera was pushed through the pipe. The water was heavily silted and made the inspection difficult. Approximately 24 meter (80 feet) of the pipe were inspected going downgrade. The camera was then positioned in the pipe facing upgrade. At that time, there was no water standing in the pipe at the base of the inspection hole. Approximately 0.9 meter (three feet) upgrade a mound or dam of material approximately 25.4 mm (one inch) in height was damming the mainline. The camera was pushed through the dam of material and water flowed rapidly downgrade. The camera was pushed further upgrade and another dam was observed approximately 2.1 meter (seven feet) from the inspection hole. The dam was approximately 16 mm (three inches) in height. Again, the dam or blockage was penetrated and water flowed rapidly downgrade through the pipe. Another dam of material was encountered approximately 3.7 meter (12 feet) from inspection hole. A trench was excavated down to the top of the mainline and a sample of the blockage was extracted. The material was analyzed and found to be largely calcium carbonate.

After further inspection, an outlet pipe was found approximately 213 meter (700 feet) downgrade from the initial inspection hole. The headwall was completely covered, and the outlet pipe was plugged with silt and roots. The outlet pipe and the mainline were inspected with the Cues Camera. Dams of material were observed approximately every 0.9 to 1.5 meter (three to five feet). It appears the dams begin to occur at the plugged outlet where water was ponding inside the pipe. Additionally, the dams may form from material settling out in sags in the pipe.

A Type E edge drain was inspected at Milepost 57.05 in April 1994. The panel had been backfilled with sand and the pavement had been broken and overlaid in 1993. The bottom 1/3 of the panel was severely compressed. The bottom third of the panel was also bent toward the center of the trench. It appears the panel may not have been installed flush against the wall and/or the bottom of the trench was irregular. The upper 2/3 of the panel appeared to be in excellent condition.

The associated outlet pipe was inspected. The outlet was 1/3 blocked with precipitates that had accumulated behind the rodent screen. Slight to moderate sagging had occurred in the double-wall polyethylene outlet pipe.

A Type E drain was inspected at Milepost 56.5 in the westbound, outside shoulder in May 1994. The panel was slightly compressed in areas between support columns. The core area of the panel had been reduced by approximately five to 10 percent. The panel was compressed slightly at the base. Overall, the panel was clean and open.

An additional hole was excavated at approximately Milepost 57. The Type E panel was clean and open, with no signs of vertical or lateral distress.

Edge drains on the Bluegrass Parkway were inspected in April 1994, at Milepost 34.2, in both the eastbound and westbound outside lanes. Type C edge drains were installed on the eastbound side. The outlet was inspected with the Cues

Camera. The outlet coupling for the Type C system appeared to be significantly compressed. The open area of the coupling appeared to be reduced approximately 90 percent. The Type C panel was borescoped. A considerable amount of fabric intrusion had occurred in the core of the panel. The core area of the panel had been reduced by approximately 20 to 25 percent. The more open side of the drain was facing the sand backfill.

Type E edge drain was borescoped in the westbound direction at Milepost 34.4. The panel appeared to be clean and open, with no signs of vertical or horizontal compression.

The outlet pipe draining this section of edge drain was inspected. Sagging of the outlet pipe was apparent behind the headwall. The panel core had lost approximately 10 to 15 percent of its flow area due to the panel being cut too far from support columns during installation.

Approximately 12.7 mm to 19 mm (1/2 inch to 3/4 inch) of settlement was observed in the edge drain asphalt patch at several of the lateral joints and cracks in the PCC. It appears that several of the joints and cracks may be allowing the sand backfill to migrate into the open joint or crack in the pavement.

3.1.6 Western Kentucky Parkway

A stained area occurring at the centerline and shoulder of the Western Kentucky Parkway (WKP) at milepost 84.9 was investigated in April 1992. The adjacent outlet was inspected. The 101 mm (4-inch) outlet pipe was severely compressed approximately 7.5 meter (24.5 feet) from the headwall. Staining was also observed at Milepost 84.6 in the centerline and the shoulder of WKP. A cross drain had been installed approximately 23 meter (75 feet) upgrade from the edge drain outlet. Visual inspection of the outlet with the mini camera was difficult due to the large amount of silt in the pipe. It appeared the outlet pipe was crushed approximately 6 meter (20 feet) from the headwall. An old design of Type D drains was also inspected. The bottom three rows and top three rows of the edge drain were partially collapsed. The drain was one-half full of water.

A pavement failure was investigated at Milepost 91, in the eastbound, inside lane of the WKP in April 1994. The PCC pavement had been broken and overlaid in September of 1991. Round pipe edge drains were installed prior to breaking and seating. Two outlets in the vicinity of the failed area were inspected. The first outlet pipe was 25 percent crushed on the backside of the headwall, and at approximately 1.1 meter (3.5 feet) into the outlet, the pipe was completely blocked by a guardrail post.

The second outlet inspected was approximately 137 meter (450 feet) east of the

first. The outlet pipe was in good condition up to the junction between the cross drain and the main line. The cross drain appeared to be completely blocked with sediment and possibly crushed.

In the vicinity of Milepost 42.5 (just west of a bridge end), five outlets were inspected in May 1994. The first outlet past the bridge end was sagged at three feet and 2.1 meter (seven feet) from the headwall. At 2.7 meter (nine feet) from the headwall, the outlet pipe was crushed. The headwall had settled backward or had been improperly installed.

The second outlet west of the bridge end was in good condition to approximately 4.3 meter (14 feet) from the headwall. At 4.3 meter (14 feet), the outlet pipe was approximately 25 percent blocked with a precipitate dam, and at 5.2 meter (17 feet) the pipe was 80 percent blocked with rock and other precipitates. The pipe was also approximately 10 percent crushed.

The third outlet west of the bridge was crushed approximately 30 percent at three feet from the headwall. In addition, the pipe was completely blocked with what appears to be backfill material and other precipitates.

The Type D drain was excavated in the vicinity of the third outlet. The panel was completely full of sediment. It is apparent that the damaged outlet is causing fines from the broken concrete to be deposited in the core of the panel.

Edge drains on the WKP from Milepost 62.87 to Milepost 65.68 were inspected in May 1994. Considerable settlement had occurred in the asphalt patch over the edge drain when vehicles were forced onto the shoulder during construction. Forty edge drain outlets were investigated. Approximately 23 percent of the outlets were not functioning properly. Several types of problems were observed during the inspection of the outlets and the mainline of the edge drain. In two areas, the 101 mm (4-inch) pipe edge drain had been partially crushed due to settlement of the backfill. T-connectors were modified to four-way connectors by cutting and splicing an additional connector into the top of the T-connector. These connectors were used in vertical sags which drained both directions of the outside shoulder, plus connected to 101 mm (4-inch) cross drain (draining the median) and to the outlet pipe. In approximately seven instances, the pipe which was spliced into the T-connector was shoved completely across the connector blocking the outlet. An outlet pipe was also crushed behind the headwall. Debris from construction was in several of the main lines and outlets.

3.1.7 Interstate 24

Four edge drain outlets were inspected in the westbound lane on Interstate 24, near Milepost 60.2 in May 1994. The first outlet pipe was completely crushed

approximately 0.6 meter (two feet) from the headwall. The second outlet pipe was full of aggregate approximately 0.6 meter (two feet) from the headwall. The third outlet pipe was completely crushed approximately 0.9 meter (three feet) from the headwall. The fourth outlet was approximately 50 percent crushed 1.5 meter (five feet) from the headwall.

The round perforated pipe edge drain was excavated approximately 6 meter (20 feet) upgrade from the third headwall. The trench was excavated to the top of the unwrapped, 101 mm (4-inch) perforated pipe. The trench was backfilled with No. 57 stone. The Cues mini camera was used to inspect the edge drain. In the eastbound direction the crown of the pipe was buckled at approximately 12.7 mm (0.5 inch), 1.2 meter (four feet) from the excavation. The pipe was buckled approximately 51 mm (2-inches) at 3 meter (10 feet) from the excavation. The edge drain also was inspected in the westbound direction. A 51 mm (2-inch) buckle was observed in the crown of the pipe 9.7 meter (32 feet) from the excavation . The pipe appeared to be clean.

3.1.8 Pennyrile Parkway

Type D drains were inspected in November, 1992 on the Pennyrile Parkway at Milepost 23, in the northbound lanes. Numerous places were observed (prior to placement of the asphalt plug) in the first 1.6 km (mile) of construction where the elevation of the top of the edge drain was almost even with the top of the pavement. The edge drain was borescoped at Milepost 23 in the inside shoulder. The top row of support columns was slightly rolled over, and some fabric intrusion and buckling were observed in the base of the drain. Overall, the drain appeared to be in reasonably good condition.

The edge drain was borescoped at Milepost 26. The top row of support columns had rolled over and fabric had intruded into the core of the drain. Moderate fabric intrusion was observed between rows No. 3 and No. 4. The panel was slightly "J'd" below the sixth row.

The edge drains were inspected in three locations in May 1994, at the inside shoulder, near Milepost 23.9. During all three borescope inspections, the top one to two rows of support columns were bent over and fabric intrusion into the core had occurred. In one location, the top two rows had been compressed completely together. The panel was slightly "J'd" at the bottom. Two associated outlet pipes were inspected in the area. At Station 1530+00, the outlet pipe was 85 percent blocked by rock and debris 4.6 meter (15 feet) from the headwall. Sagging was observed in the outlet pipe directly behind the headwall, but it was clean and open to the panel.

A total of 364 headwalls and outlets were investigated on the Pennyrile Parkway in 1994. Approximately 17.5 percent of the outlet pipes were significantly crushed or contain significant amounts of backfill material. Approximately 9 percent

were slightly crushed.

3.1.9 Summary of Construction Factors

Findings from this study indicate there are several construction factors that control the performance and longevity of a highway edge drain system. Approximately 20 to 30 percent of the edge drain outlet pipes throughout the state were significantly damaged (crushed) during installation.

In addition to outlet pipes being crushed, numerous pipes were observed that contained sags or were installed to an improper grade permitting debris to accumulate.

Damage to panel drains during installation is substantially less when using sand backfill. Vertical compression and core loss have been observed in some of the panels when the sand is not properly densified during installation. Horizontal compression from break-and-seat operations may be a problem in some areas.

Significant crushing of round pipe will likely occur when the sand backfill is not properly densified and traffic is allowed to travel over the trench.

Some headwalls have not been installed with the proper slope. This may be due to poor preparation of the subgrade prior to placing the headwall.

3.2 Evaluation of Maintenance Factors

Also as a part of Objective No. 1, an attempt was made to determine the apparent level of maintenance on edge drain headwalls. In September 1993, headwalls were inspected on the Mountain Parkway, Interstate 64, and Interstate 75. Table 1 indicates that 49 headwalls were inspected between Milepost 6 and Milepost 25 on the Mountain Parkway. Of those 49 headwalls, 38 percent were clean, 29 percent were partially covered, 27 percent were covered, and six were verified as being plugged. This number could be as high as 33 percent being plugged since 13 of the covered outlets were not excavated.

A total of 123 outlet headwalls were inspected on Interstate 64 in three locations (Table 2). On the average, 60 percent of the headwalls were clean, 28 percent were partially covered, 10 percent were covered, and two percent were verified as being plugged. Again, the number plugged could be as high as 12 percent as all of those covered were not excavated.

A total of 67 outlets were inspected on Interstate 75 between Milepost 3 Milepost 48 (Table 3). Of the 67 headwalls inspected 57 percent were clean, 19

percent were partially covered, 19 percent were covered, and five percent were plugged. The number plugged could be as high as 24 percent.

The headwall data from these three routes are averaged in Table 4. This table indicates that 55 percent of the headwalls were clean, 26 percent were partially covered, 16 percent were covered, and from four to 20 percent were plugged.

3.2.1 Summary of Maintenance Factors

Field inspection of edge drain headwalls in Kentucky conducted prior to this study and during this study (including Interstate 75, Interstate 71, Interstate 64, and Mountain Parkway) indicate only 46 percent of the headwall outlets are free of debris (clean), 31 percent were partially covered, 12 percent were covered and 11 percent were plugged (completely blocked).

Because less than one half of outlet headwalls are free of debris, it appears the effectiveness of longitudinal edge drain systems is being severely compromised. An aggressive program of cleaning and maintaining headwalls would greatly enhance the return on the investment made in these systems.

4.0 DEVELOPMENT OF GENERIC SPECIFICATION FOR PAVEMENT EDGE DRAINS (OBJECTIVE NO. 2)

4.1 Laboratory Evaluations Conducted in This Study for Panel Edge Drains

To accomplish Objective No. 2 of this study (development of a generic specification) and to assist in quantifying some of the parameters listed in Objective No. 1, it was determined that a laboratory test should be developed that could approximate field test conditions where test variables could be controlled. Such a test would allow comparison of behavior between different panel drain designs. Current laboratory test methods were reviewed and it appeared that the flat parallel plate test (ASTM D 1621) does not model the vertical or eccentric components of stress experienced by the panels in the field. Work performed by Frobel (3) on eccentric (angle) loading of panel drains simulates shear type forces that are placed on panels during and after installation; however, this test does not model the full vertical component. It appears most of the distress in the panels is caused by vertical compression and eccentric loads. In response to this, a vertical edge drain compression chamber was constructed which closely simulates in-situ conditions.

4.1.1 Vertical Edge Drain Compression Chamber

A vertical edge drain compression chamber was constructed to test edge drains under conditions similar to those encountered in the field. The inside chamber dimensions are 311 mm (12.25 inches) in length, 106 mm (4.20 inches) in width, and 501 mm (19.75 inches) in height. The front and the back of the chamber are made of 12.7 mm (one-half inch) tempered glass for viewing the specimen. The remainder of the chamber is constructed of stainless steel, and high grade aluminum alloy. The bottom of the chamber is perforated to allow water to escape. A 101 mm (4-inch) by 279 mm (11-inch) aluminum plate 25.7 mm (one inch) in thickness is used as a loading plate. The chamber is shown in Figures 2 and 3.

4.1.2 Method of Testing

The vertical dimension of the cores was not modified, except for the Supac panel. Initially, Type F panel was an 457 mm (18-inch) panel which was modified to a 305 mm (12-inch) panel for testing. Six different brands of edge drain panels were tested during this study. Their core profiles are shown in Figure 1. Four series of tests were conducted on each panel. The edge drain samples were cut into 298 mm (11.75-inch) lengths. The cores of the samples were cut so that the filter fabric was approximately 6.3 mm (0.25 inch) longer than the ends of the core. The sample was placed in the chamber (against the wall of the chamber) parallel with the long dimension of the chamber. Plexiglass inserts 6.3 mm (0.25 inch) in thickness were placed between the sample and viewing windows. The specimen was then backfilled with a coarse clean sand. The sand was placed to a height of 101 mm (four inches) above the top of the panel. The loading plate was placed on top of the sand. The chamber was then placed into an MTS load frame. The initial height of the sample was measured. A florescent light was secured to the back glass window. The illuminated core of the drain was traced onto 216 mm by 355 mm (8.5-inch by 14-inch) graph paper (The area of the traced cores was later calculated using a planimeter). The load was applied at a rate of 0.44 kN (100 pounds) (15.6 kPa (2.27 psi based on the area of the loading plate)) per minute. The vertical deflection of the panel was recorded at 0.44 kN (100-pound) increments and the core was traced at every 1.1 kN (250-pound) (39.2 kPa (5.68-psi)) increment. The load was held constant for approximately two minutes while the core was traced. The test was discontinued at 4.4 kN (1,000 pounds) (156.5 kPa (22.7 psi)). The resulting horizontal stress from the 4.4 kN (1,000-pound) vertical load was derived from finite element modeling and it was measured directly using an earth pressure meter. The calculated, derived, and measured horizontal stresses are discussed later.

4.1.3 Testing Series

The tests were conducted in Series 1 with air-dry sand (approximate moisture content of 4.0 percent) and low density (approximately 13 kN/m^3 (83 lb/ft^3)), with the open side of the drain facing the sand backfill. The tests were conducted in Series 2 with wet sand, high density and with the more open side of the drain facing the backfill. The sand was densified to approximately 18 kN/m^3 (114 lb/ft^3) by pouring one gallon of water on top of the sand. (Approximately 3.8 litres (one gallon) of water per linear 0.3 meter (foot) of drain is used to densify the sand during actual field installations). In Series 3, the tests were conducted with the more open side of the panel facing the wall of the chamber and the sand was not densified (sand was 4.0 percent moisture and 13 kN/m^3 (83 lb/ft^3)). The panels were tested in Series 4 in the same manner as in Series 3, except the sand was densified as in Series 2.

4.1.3.1 Results of Series 1

The vertical deflection measurements are contained in Figure 4 and Table 5. The Type E core deflected the least of the panels tested. At 160 kPa (23.2 psi), Type F deflected 6 mm (0.24 inch) (1.9 percent). Type D deflected the most. At 160 kPa (23.2 psi) of vertical load, Type D deflected 52.8 mm (2.08 inches) (16.8 percent).

The changes in core capacity of each panel drain at 160 kPa (23.2 psi) are contained in Figure 5 and Table 6. The two inclosed cores performed the best (Type F and Type E). The core capacity of Type E core increased by 2.1 percent and Type F core decreased by 2.46 percent. The capacity of Type D core reduced the most at 57.6 percent. The capacity for each core type for a given load is shown in Figure 6 and Table 7.

4.1.3.2 Results of Series 2

The tests in Series 2 (dense sand) were performed at the same rate, and data were recorded at the same frequency. In most cases, increasing the density of the sand increased the performance of the panel drain.

At 160 kPa (23.2 psi), the Type E core deflected the least. The Type E core deflected 4.5 mm (0.18 inch) (1.4 percent). The Type B core deflected the most at 23.4 mm (0.92 inch) (8.1 percent). The deflection of each panel is shown in Figure 4 and Table 5. The Type A core was the only edge drain that increased in vertical deflection when the sand was densified. The most significant change occurred in the Type D

core and the Type F core. The Type D core decreased by 62 percent, and the Type F core decreased by 68 percent.

The change in core capacity at 160 kPa (23.2 psi) is shown in Figure 5 and Table 2. The core capacity of the Type E core increased by 1.1 percent, and the Type B core decreased by 33.80 percent. The most significant change in core capacity when the sand was densified was the Type D core which increased 32 percent. The capacity of each core type for a given load is shown in Figure 6 and Table 7.

In comparing the results from these tests, it is apparent that the Type E core performed better than the other panels. The core capacity of the two enclosed cores (Type E and Type F) deflected less than the other four more open cores. The more open cores (Type A, Type B, Type C, and Type D) had core losses equal to or greater than 25 percent. It appears that fabric intrusion between the support columns and rolling over of the top and bottom rows of support columns were causing the reduction in core area.

4.1.3.3 Results of Series 3

A third and fourth set of tests were conducted on the open-type cores to help minimize fabric intrusion. The panels were turned backward in the compression box in these series.

It is also possible to turn these panels backward in the field. The open area on the backside of the Type B core was 15.3 percent open; the Type C core was 13.5 percent open; the Type A core was 11.3 percent open; and Type D core was 47.6 percent open. The open area of the Type E core was 3.9 percent on one side and 5.8 percent on the other. The Type F core had an open area of 0.80 percent.

The panels were tested with the more open side of the panel facing the wall of the chamber and the sand in a loose state. The Type A core deflected the least (1.6 percent) at 160 kPa (23.2 psi), and the Type D drain deflected the most at 12 percent. In all cases, the more open panels deflected less in Series 3 than in Series 1 (Figure 4 and Table 5).

In most cases, the reduction in core capacity was less in Series 3 than in Series 1 and 2. Type A, Type B, and Type C cores had less core reduction in Series 3 at 160 kPa (23.2 psi). The Type D core had greater core loss in Series 3 than in Series 2 (Figure 5 and Table 8). The capacities of each core type for a given load are plotted in Figure 6 and are listed in Table 3.

4.1.3.4 Results of Series 4

The performance of the open-type cores in most cases increased when the panels were turned backward and the sand densified. The Akwadrain core deflected the least in the vertical direction. The Akwadrain core deflected 3.1 percent at 160 kPa (23.2 psi) and the Contech core deflected the most at 5.0 percent (Figure 4 and Table 1).

The percent changes in the core capacities for a given load are shown in Figure 5 and Table 4. At 160 kPa (23.2 psi), the Type A core had less capacity loss and the Type B core had the greatest capacity loss of 15.2 percent. The capacities of each core type for a given load are plotted in Figure 6 and are listed in Table 7.

4.1.3.5 Summary of Vertical Compression Tests

Information obtained from the four series of tests that were performed indicates that the Type E panel performed the best of the six panels. The Type E panel had the least amount of vertical deflection and the least amount of core reduction in most of the four series of tests (In Series 3, the Type E core deflected vertically 1.9 percent and the Type A core deflected 1.6 percent). The Type E core also had the largest amount of core flow area. The test data indicate that solid type cores (Type E and Type F) had the least amount of core reduction in all the tests. Type E core area actually increased by one to two percent in all the tests. The Type F core decreased two to four percent. Although the Type F core showed little core reduction in all the tests, compression occurred in the webs linking the round flow tubes when the sand was loose. The more open cores (Type A, Type B, Type C, and Type D) are prone to loss of core flow area due to the top rows of support columns rolling over and the rigid backing folding and compressing. In all cases, the more open cores performed substantially better when the more open side was placed against the wall of the chamber. The Type A core showed the least amount of distress of the more open type cores. The Type A core is of similar design to the Type B and Type C cores, but is more rigid because of its chemical composition. The Type A core is PVC. The other cores are high density polyethylene.

4.2 COMPARISON OF LABORATORY TEST METHODS

4.2.1 Flat Parallel Plate Test

Flat parallel plate tests were conducted according to ASTM D 1621. The load was recorded at 10 percent strain except for the Type A core. The Type A core exceeded the limits of the testing equipment and the test was aborted at eight percent strain. At eight percent strain, the Type A core was 574 kPa (83.3 psi) (highest of all the cores tested). The full results are plotted in Figure 7.

4.2.2 Eccentric Loading

Eccentric load tests conducted by Frobel (3) indicated that the Type D core was more prone to collapse due to eccentric loading. Frobel's data indicated that the Type B and Type E were more stable. The upper edge of the Type B core rolled over at high eccentric loading.

4.2.3 Vertical Compression Test

Roll-over of the first row of support columns of Type A, Type B, Type C, and Type D cores was apparent in all four series of tests. Vertical compression and folding of the rigid backing under loose sand conditions also was apparent in the same cores. Compression of the interlinking ribs of the Type F drain folded under loose sand conditions. The Type E core showed the least amount of distress in all four series of tests conducted.

4.3 Horizontal Stress Analysis

4.3.1 Horizontal Stress (Finite Element Modeling)

To further assist in fulfilling Objective 2, it was necessary to estimate or determine the magnitude of horizontal stress experienced by a panel drain. Finite element modeling was conducted to estimate horizontal forces produced during loading of a panel drain system. A modulus of elasticity of 68,947 kPa (10,000 psi)

and a Poisson's ratio of 0.35 was assumed for the sand backfill. A modulus of elasticity of 3,447 kPa (500 psi) and a Poisson's ratio of 0.45 was assumed for the edge drain panel. As shown in Figure 8, at a depth of 152 mm (six inches) (Y=6 inches at center of panel) the resulting horizontal force at 156.5 kPa (22.7 psi) vertical load is approximately 16.5 kPa (2.4 psi). The finite element plot indicates higher horizontal stresses occur at the top and the bottom of the panel. A horizontal stress of approximately 96.5 kPa (14.0 psi) occurs near the top, and approximately 48.3 kPa (7.0 psi) at the bottom of the panel. These points are probably higher than actual values because the panel was modeled as a rigid structure and the node points (nodes between the sand and the panel) were attached, not allowing the sand to migrate around the panel.

4.3.2 Horizontal Stress (Measured in Laboratory)

To determine if horizontal stresses measured in the compression chamber developed in this study approximated those predicted by the finite element analysis, horizontal stresses on the sidewall of the chamber were measured using a round, 228 mm (9-inch) diameter earth pressure meter. The measured horizontal force was approximately 19 Kpa (2.76 psi) at 156.5 kPa (22.7 psi) vertical pressure. This is good agreement with the theoretical pressures calculated at the center of the panel.

4.3.3 Horizontal Stress (Field Measurements)

Horizontal and vertical stresses were measured in the field during construction using one round, 228 mm (9-inch) diameter, and two, 50.8 x 254 mm (2 x 10-inch) rectangular earth pressure meters. Actual installation pressures were not attainable due to the nature of the contractor's schedule. Loads were applied to the top of the sand backfill using a crew cab pickup truck and a loaded Class 7 dump truck, with the third drop axle raised. At the first test site, using the crew cab pickup truck for loading, a vertical pressure of 194 kPa (28.25 psi) was measured. A horizontal pressure of 15.2 kPa (2.2 psi) was measured with the round gauge (placed at the bottom 1/3 of the trench), and 41.4 kPa (6 psi) was measured with the rectangular gauge (located near the top of the trench). At the second test site, using the loaded dump truck, a horizontal pressure of 61 kPa (8.85 psi) reading was recorded. The full vertical pressure reading was not obtained because of the slow reaction time of the earth pressure meter and a tight construction schedule. A vertical pressure of 468 kPa (68 psi) (plus) was recorded.

4.4 Correlation of Laboratory Tests with Field Performance

To date, only four of the six core types tested in the laboratory have been monitored in the field (Type B, Type C, Type D, and Type E). The material was compacted with a vibratory compactor. Numerous miles of the earlier Type D core were installed in this manner. All of the five sites that were borescoped and excavated showed similar signs of core collapse (column collapse) as indicated by Frobel's eccentric loading testing. Slight to moderate core compression was noticed in field inspections of the earlier Type E core.

Since 1989, numerous miles of edge drains have been installed on the backside of the trench and backfilled with a sand slurry. Two miles of a core similar to Type B core and several miles of Type E core were installed on the Mountain Parkway and on Interstate 75 in Kentucky. At both sites, the core similar to Type B core was installed with the fabric facing the sand backfill. In both cases, the top row of support columns were rolled over and slight fabric intrusion had occurred in areas. Series 1 and Series 2 laboratory tests showed similar signs of this type of roll over starting in the very early stages of the tests. The Type E core installed at both sites appeared to be in excellent condition. There were no signs of vertical or horizontal compression. This behavior corresponds well with Type E behavior as observed in the compression chamber.

Several miles of a new design of Type D core were installed in 1990 and 1991. Installation was made with the more open side facing the shoulder. Rolling over of the top row of support columns occurred during installation. Vertical compression tests in the laboratory showed similar signs of this type of "roll over" starting in the very early stages of the test.

It appears that the behavior exhibited by the various panels tested in the compression chamber closely resembles observed behavior in the field. Also, horizontal stresses calculated and measured in the laboratory closely approximated those horizontal stresses measured and observed in the field. Consequently, it was concluded that results obtained from the compression chamber in the laboratory could be used in testing panel drains for acceptance as well as assist in developing a specification for panel edge drains. Furthermore, it is concluded that the flat parallel test (ASTM D 1621) is not an appropriate test for determining the required horizontal strength for panel drains as the stresses in that test are much higher than those measured in the field.

4.5 Performance of Pavement Edge Drain Backfill and Fabrics

The filter fabric that wraps the core and the trench backfill material becomes an integral part of an edge drain system; therefore, its performance and behavior in

the field is critical to the effectiveness of the entire drainage system. These factors must be examined in developing a generic specification. Performances of the filter fabrics, stone, and sand backfills of a number of sites were evaluated by excavation, gradation analysis, permeability testing, and microscopic analysis.

Sand backfill samples were excavated at four separate edge drain sites which had been installed with sand slurry. The sand backfill samples were collected by dividing the cross section of the sand backfill into approximately three lifts. The sand was then carefully sliced and extracted from the three lifts. After extracting the sand, a gradation analysis was performed on the backfill samples.

Samples were obtained from the Mountain Parkway in 1993, which was approximately four years after the pavement had been broken, seated and overlaid. Figure 9 is a contour plot illustrating the results of the gradation. At an elevation of 17 cm from the bottom of the trench, which is near the base of the broken concrete slab, is the highest concentration of material passing the 60 sieve (approximately 11.0 to 11.5 percent). That concentration drops dramatically as the distance to the panel drain decreases. This indicates that the sand backfill is effectively filtering and trapping the finer material and preventing much of the fine debris from reaching the filter fabric.

Figure 10 shows the same relationship for the material passing the 200 sieve. The concentration of -200 material drops from approximately 5.0 percent on the pavement side of the trench to approximately 3.0 percent next to the panel drain.

Sand backfill samples were collected on the Bluegrass Parkway at Milepost 57.05 in 1994. This was one year after the edge drains had been installed and the old concrete pavement was broken, seated, and overlaid. Figure 11 shows that the percentage concentration of -200 material. In Figure 11 the -200 material increases near the top of the panel. This increase is likely due to influx of material from the construction joint on the shoulder side of the trench.

Samples obtained from Milepost 34.2 on the Bluegrass Parkway in 1994 were also analyzed. This section of pavement was the original concrete slab. No rehabilitation had been performed apart from retrofitting the edge drains. The drains had been in service approximately three years at the time the samples were collected. Figure 12 shows the same distinct decrease in the concentration of material passing the 200 sieve from the pavement side of the trench to the drain panel. It should be noted that the highest concentration is near the top of the pavement side of the trench. This appears to indicate that, for an unbroken concrete pavement, much of the fine material entering the drain trench may be from the construction joint between the concrete pavement slab and the asphalt shoulder.

Analysis of sand backfill samples collected from Milepost 122.9 on Interstate 75 was less conclusive. This was a round pipe section. Figure 13 shows a higher concentration of -200 material on the pavement side of the trench. However, there was also a higher concentration of -200 material near the outside edge of the trench approximately six inches from the bottom of the trench. This is currently

inexplicable.

Overall, the gradation analysis performed on the sand backfill from the current edge drain installation specification showed that the sand backfill appears to effectively filter out some of the minus 200 material. Blinding of the sand nor the filter fabric at this time do not appear to be a problem. Further testing is needed, but it appears the sand acts as a filter not allowing the fines from the broken concrete to flush into the filter fabric immediately after construction.

Further evidence that the sand backfill helps to filter out the fine debris and assist in preventing clogging of the fabric was provided by a microscopic analysis performed on the filter fabrics of edge drains installed on the Mountain Parkway under the old specification (trench backfilled with cuttings) and the new specification (sand backfill). The analysis of the filter fabric of edge drains installed under the new specification showed only minimal signs of any reduction of the average opening size (AOS) of the fabric due to clogging or blinding by fine sediments (Figure 14). Microscopic analysis of edge drains installed under the old method showed that the AOS of the filter fabric had been significantly reduced (Figure 15). Electron microscope analysis of the filter fabrics installed under the old method indicated that most of the residue retained on the fabric was broken concrete debris (Figure 16). This is indicated by the high concentrations of silica and calcium.

Additionally, filter fabric samples were collected during the reconstruction of the Interstate 64 and Interstate 75 interchange in Fayette County in 1993. The drain had been in service approximately 15 years. The edge drain consisted of a 101 mm (4-inch) pipe in a fabric-wrapped trench that was backfilled with No. 57 stone. Several problems were apparent during the excavation of the pipe edge drain. It appears the outlet pipe draining this section of edge drain had been partially crushed during construction. In addition, it also appears that tack coat had been oversprayed onto the filter fabric during construction. Microscopic analysis of the tack coated filter fabric showed significant loss in the AOS of the fabric (Figure 17). Microscopic analysis also showed that the filter fabric was severely clogged with fines (Figure 18). Permeability tests were performed on filter fabrics from the fabric wrapped trench. These tests confirmed that filter fabric had become almost impermeable. Gradation analysis of the 57-size backfill showed slight increase on the No. 200, and No. 4 sieve sizes (Figure 19). It appears that the blocked outlet had contributed to the retention of sediments in the filter fabric and the backfill. This is further evidence that a secondary sand filter between the filter fabric and the pavement edge is an important component of the drainage system in preventing the fabric from clogging.

4.6 Generic Specification

Using the information developed from the laboratory testing and field work

discussed, an edge drain specification for highways was developed in fulfillment of Objective No. 2. This specification is included in Appendix A. The specification includes laboratory testing procedures, installation guidelines, and acceptance guidelines.

5.0 LATERAL EFFECTIVENESS OF THE PAVEMENT EDGE DRAIN SYSTEM (OBJECTIVE NO. 3)

Objective No.3 of this study was to address the question of the effectiveness of edge drain systems in draining water laterally through the pavement structure. This was evaluated using subgrade moisture samples and infrared thermography.

5.1 Subgrade Moisture

Because soil subgrades are usually more impermeable than other components of the pavement, and because soil subgrade behavior is highly dependent on moisture content, it was decided to use subgrade moisture as an index of the effectiveness of lateral drainage. Subgrade moisture samples were obtained on Interstates and Parkways in sections with edge drains and in sections without edge drains. The samples were obtained by drilling a 15.8 mm (5/8 - inch) hole at 0.3- to 0.6-meter (1- to 2-foot) intervals across the pavement structure to the top of the subgrade. A 12.7 mm (1/2 - inch) aluminum electrical conduit was then driven 152 mm (six inches) into the subgrade. The samples were obtained at 10 sites with edge drains and at five sites without edge drains. Thirteen of the sites were located on PCC pavements. Two sites were located on the Mountain Parkway which had been broken and overlaid. The sites are listed below:

Edge Drain Sites

Mountain Parkway, MP 21.6
Mountain Parkway, MP 21.4
Bluegrass Parkway, MP 58.4
Bluegrass Parkway, MP 57.6
Bluegrass Parkway, MP 33.3
Bluegrass Parkway, MP 33.0
Bluegrass Parkway, MP 32.4
Bluegrass Parkway, MP 31.2
Bluegrass Parkway, MP 29.0
Interstate 64, MP 72.2

Non Drained Sites

Interstate 64, MP 74.0
Bluegrass Parkway, MP 38.0
Bluegrass Parkway, MP 37.0
Bluegrass Parkway, MP 57.6 (Eastbound)
Bluegrass Parkway, MP 58.4 (Eastbound)

Five moisture samples were obtained at each site. The samples were taken at the outside shoulder interface, right wheel path, between the wheel paths, left wheel path, and at the centerline of the pavement. The moisture data at each site were then normalized to the highest moisture content. Figure 20 shows the average of these data. One line represents the average of the 10 sites with edge drains, and one line represents the average of the five sites without edge drains. Clearly, there is a dramatic decrease in the moisture content at the shoulder on the sites that have edge drains. As mentioned earlier, Jeffcoat et. al. (1) have indicated that shoulders without drainage can act as a dam to transverse pavement drainage. Figure 20 clearly supports that statement.

If it is assumed the moisture content at the edge of the driving lane farthest from the shoulder (3.6 meter (12 feet)) is the point least influenced by the edge drain, then it can be assumed the moisture contents for both pavements with and without edge drains would be approximately equal at that point. Using this assumption, the two curves in Figure 20 can be adjusted to where the points 3.6 meter (12 feet) from the shoulder are equal. Figure 21 is the result of that adjustment. The difference in the moisture contents at the shoulder can now be compared. This comparison reveals the subgrade moisture is approximately 28.0 percent lower for sites with edge drains in comparison to sites without edge drains. This indicates there is a dramatic effect on subgrade moisture produced by edge drains. The percentage reduction appears to be fairly linear and is approximately 2.5 percent per foot of distance from the centerline joint of the two driving lanes.

5.2 Thermographic Inspection of Pavement Surface

An Inframetrics Model 740 thermographic imager was used to assist in the evaluation of pavement moisture. The imager produces a video image of infrared surface radiation. The infrared scanner was used on the Bluegrass Parkway in September 1993 on a section without edge drains from Milepost 37.0 to Milepost 35.7 in the westbound, outside lane. The scanner was also used on an edge drain section west of Milepost 35.7. Both sections of pavement were unbroken concrete slabs. Type E edge drains had been installed approximately two years prior to the inspection.

Figure 22 is a thermographic image taken at a pavement joint. The blue, purple, and magenta colors represent cooler portions of the pavement slab in respective order, whereas the green and yellow colors represent warmer portions of the pavement as indicated by the temperature scale in that figure. The line in that image labeled Profile 1 runs transversely across the slab from the centerline joint to the right edge of the pavement near the white paint stripe delineating the pavement edge. (The cool white paint stripe appears as the thick black line in the upper right-hand corner of the image.) The temperature gradient of that profile line is represented graphically on the right-hand side of the page.

During daylight hours, water located under a pavement slab will make the slab cooler. It should be noted from Figure 22 that the cooler temperatures (magenta) are located along the right pavement edge next to the shoulder, and for a short distance across the pavement at the joint. These cooler temperatures indicated that water is trapped at an impermeable shoulder and at the joint.

The temperature profile on the right-hand side of the page shows a rather uniform temperature profile of 210.2° C (68.3° F) from the centerline joint to near the center of the slab. From there, the temperature drops rapidly to the edge of the slab where the temperature is approximately 19.2° C (66.5° F) (a total temperature differential of -16.7° C (1.8° F)). This graphic profile also gives the general extent of the water located in the joint.

A second image was obtained at a pavement joint at a site only 2.57 km (1.6 miles) from the first site and only 16 minutes later. This site had longitudinal edge drains. The temperature gradient across the pavement (Profile 1) was more uniform (a temperature differential of -17.33° C (0.8° F)) and slightly warmer than the pavement with no edge drains. This indicates there was less moisture under the slab, and the moisture distribution was more uniform. Also, there appears to be no excess moisture at the pavement joint.

Although infrared technology will be developed further during this study, these preliminary images clearly show that edge drains are effective at removing water from the pavement structure.

6.0 EFFECTS OF PAVEMENT EDGE DRAINS ON PAVEMENT PERFORMANCE (OBJECTIVE NO.4)

From the previous information discussed in this report, it appears that edge drains are effective in removing water from under a pavement slab. However, do the effects of edge drains actually increase the performance life of a pavement? To address this question and to fulfill Objective No.4, the Falling Weight Deflectometer (FWD) was used to determine subgrade strength and Ride Index (RI) data (obtained from the Pavement Management Branch, of the Kentucky Department of Highways) were analyzed for a number of pavement sections.

6.1 FWD Tests

FWD tests were performed on a section of the Bluegrass Parkway from approximately Milepost 25.5 to Milepost 35.0. The tests were conducted in the westbound direction prior to installation of Type E edge drains. FWD tests were performed again approximately two years after the edge drains were in service.

Figure 24 shows that the average subgrade modulus had increased approximately 64 percent since the edge drains were installed. At the same time, FWD tests were conducted on a section without edge drains from Milepost 39 to Milepost 36. Figure 25 indicates the average subgrade modulus of the area with edge drains is approximately 63 percent higher than the area without edge drains. In addition, the average subgrade modulus before the edge drains were installed was 77,221 kPa (11.2 ksi) and the average modulus of the non edge drain section taken in 1993 was 79,289 kPa (11.5 ksi). Because both sections had similar subgrade moduli before edge drains were installed, the additional subgrade strength in the section with edge drains appears to be due to the effects of the edge drains.

FWD tests were performed from Milepost 56.4 to 59.4 on the Bluegrass Parkway, in the westbound direction. Edge drains had been installed approximately two weeks prior to the FWD testing. FWD tests were also conducted in the eastbound direction which had no edge drains. The average subgrade modulus was 18.5 percent higher in the section with edge drains as compared to the section without edge drains (Figures 26 through 28). The data are summarized in Table 9. This indicates that drainage may provide a relatively rapid increase in subgrade strength after installation.

It appears this increased subgrade strength should increase pavement life. A more detailed analysis of this increased life will be conducted in the final phase of this study.

6.2 Change in Ride Quality

Figures 29 through 40 are plots of normalized RI (RI for current year divided by initial RI) shown as a function of accumulated ADT's. Twelve sections are shown from various Interstate highways. The small open squares are normalized RI in years before edge drains were installed. The small x's are normalized RI for years after edge drains were installed. The solid lines in those figures represent a regression line for all data points (both before and after edge drains). The dashed line represents a regression line for only those data points before edge drains were installed. Although there is some scatter in the data, and these lines are presented only for estimation purposes, it is clear that there is a sharp diversion between the two lines after edge drains were installed. This clearly indicates an improved performance of the pavements after the edge drains were installed.

It is recognized that the effects of weather have not been considered in this analysis. That analysis is currently in progress, and will be reported in detail in the final report of this study. However, preliminary results from the analysis show that the relationship between various weather factors (including combinations of weather factors) and change in RI appears to be relatively weak.

The data in Figures 29 through 40 are summarized in Table 10. The current

RI for a particular pavement section is listed in Column 2 and is designated as RI(1). If the critical RI is assumed to be 2.7 (critical RI value for pavements with an AADT of 8,000 or greater), the regression lines in Figures 29 through 40 can be extrapolated until they intersect an RI value of 2.7. The accumulated ADT-value at which this occurs is defined as the functional life (in terms of accumulated ADT) of that section of pavement. Columns 5 and 6 of Table 10 represent that estimated functional life in accumulated ADT's. The difference between Columns 5 and 6 (Column 7) represent the additional estimated life of a pavement with edge drains as opposed to the same pavement without edge drains.

The predicted extended life in years for a given road (Column 9) was obtained by multiplying Column 8 (1992 ADT) by 365 and dividing the result into Column 7. The extended life ranged from just over 12 years to just under two years.

The information in Column 7 of Table 10 was converted to equivalent single axleloads (ESAL's) for each pavement section in that table from information reported by Harison et. al. (6). The results were plotted as a function of Column 10 and are shown in Figure 41. There appears to be a fair correlation between the magnitude of RI when edge drains are installed and the length of extended life. In other words, the earlier edge drains are installed in the service life of a pavement the greater the performance benefit that is obtained.

7.0 COST EFFECTIVENESS OF PAVEMENT EDGE DRAINS (OBJECTIVE NO. 5)

As partial fulfillment of Objective No.5, a cursory cost analysis of edge drains was conducted. Costs and life-cycle costs will be studied in more detail in the latter part of this study and will be reported in the final report. Table 11 is a summary of this preliminary cost analysis.

Column No. 1 lists the seven Interstate highway sections for which the necessary data were available to perform the analysis. Column No. 2 lists the current RI for each of the sections, and Column No. 3 lists the minimum RI (critical) to which it was assumed these sections would be permitted to deteriorate before rehabilitation was performed. Column No. 4 lists the estimated years from time of construction that each section will reach the critical RI for both drained and undrained sections. These estimates were made from current deterioration models for each section. Four of the drained sections indicate that the critical RI would not be reached in the 30-year design life assumed in the analysis. Therefore, the cost analyses were calculated only to 30 years. Information on the estimated ESAL's listed in Column No. 4 was obtained from Reference No. 6 (Harison et. al.).

Using current average unit bid prices, the effective cost in today's dollars (using present worth factor) per 1.6 km (mile) of pavement is reported in Column

Nos. 7 and 8 for drained and undrained pavements. The cost difference between Columns 7 and 8 is listed in Column No. 9. The differences for the first six sections ranged from a low of \$2,715 per 1.6 km (mile) for Interstate 75 in Fayette County to a high of \$90,928 per 1.6 km (mile) for Interstate 24 in Christian County.

Interstate 64 in Jefferson County had only a small increase in estimated pavement life between the drained and undrained pavements. Because of the small increase, edge drains were not cost effective for that particular section with a negative difference of \$3,685 per 1.6 km (mile).

The average difference in cost per mile for all seven sections was approximately \$25,000 per 1.6 km (mile). Although this is only a preliminary analysis, it appears that edge drains can be cost effective on most pavement sections. Again, this will be analyzed in greater detail in the final report for this study.

8.0 CONCLUSIONS

8.1 Objective No. 1

It is apparent through the field analysis that maintenance and construction of the edge drain systems need to be improved. Field inspections of edge drains installed prior to 1989 indicate there are several factors effecting their performance. These factors include headwall spacings that are too large, damaged edge drains panels due to old installation techniques, failures in single wall outlet pipes, guardrail post driven through outlets, rodent screens rusted through permitting rodents to build nests which reduces outflow, and accumulation of debris in the headwall troughs causing sedimentation in the pipe and blinding of the geotextile.

The changes made in 1989 in edge drain construction and materials has had a positive impact on performance. However, several problems still currently exist. The sand-slurry backfill used for panel drains reduces construction damage, and appears to provide an extra filter medium to the drainage system. It is apparent that on several designs of panels the density of the sand backfill controls the panel performance. Proper density of the backfill needs to be achieved during construction to reduce trench settlement and structural damage to the panels.

The use of double-wall smooth-lined, corrugated, polyethylene pipe has decreased the frequency of pipe failures in the edge drain outlet pipe. Separations at couplings and sagging are still being observed. On several projects, single-wall polyethylene pipe is still being precast into the headwall. More distress has been observed in the area directly behind the headwall than any other location throughout the outlet pipe system.

Several poor construction practices were observed during this study. This

included outlet pipes that were not placed to proper grade, debris left in the outlet pipes during construction, improper backfill around the pipes, improper connections, edge drains not installed at the proper elevation, and headwalls set too low in the drainage ditches.

In addition to construction, maintenance appears to be a key factor in the performance of these drainage systems. It is apparent that improperly installed edge drains, and/or maintained drains can cause premature pavement failures. Inspection data indicate that only 50 percent of the headwalls inspected were free of debris. The No. 2 stone now being placed around the headwalls appears to be reducing the amount of vegetation and debris from accumulating in the headwall troughs.

8.2 Objective No. 2

Information obtained from the four series of tests that were performed indicates the Type E panel performed the best of the six panels tested. The more solid type cores (Type E and Type F) had the least amount of core reduction. Type D and Type F drains were the most susceptible to vertical compression when the sand was loose. The Type D core was also the most susceptible to reduction in core capacity when the sand was loose. The more open cores (Type A, Type B, Type C, and Type D) are prone to loss of core capacity due to the top rows of support columns rolling over and the rigid backing folding and compressing. In all cases, the more open cores (Type A, Type B, Type C, and Type D) performed substantially better when the more open side was placed against the wall of the chamber. The Type A core showed the least amount of distress of these types, probably due to its chemical composition (PVC).

To date, the maximum horizontal pressure measured in the field was 19 kPa (8.85 psi). It is the opinion of the authors that this was measured under extreme conditions and that actual installation pressures are probably less. Further field monitoring is necessary to confirm the maximum load needed for laboratory testing and edge drain design.

The gradation analysis performed on the sand backfill from the current edge drain installation specification showed the sand backfill effectively filters out some of the minus 200 material. Blinding of the sand at this time does not appear to be a problem. Further testing is needed, but it appears the sand acts as a filter preventing the fines from the broken concrete to flush into the filter fabric immediately after construction.

8.3 Objective No. 3

Soil moisture and thermography data indicate that edge drains help move water laterally across the pavement structure, and that the shoulder acts as a

restraining dam for pavements without edge drains. The edge drains appear to reduce the subgrade moisture as much as 28 percent.

8.4 Objective No. 4

FWD data indicate that edge drains significantly increase the strength of the subgrade by removing water. It appears this increased subgrade strength should increase pavement life.

Ride index data indicate that edge drains will add significant life to the pavement structure. Information derived from this study indicates an average extended pavement life of approximately 7 years. These data are based on edge drain systems that are most likely not fully functional and are not installed to current specifications.

8.5 Objective No. 5

Preliminary cost analysis information indicates that in most cases edge drains can be cost effective. The average cost savings per 1.6 km (mile) is approximately \$25,000. A more in-depth study on costs will be reported in the final report on this study.

9.0 RECOMMENDATIONS

It is recommended that all edge drain outlets be inspected with a Cues Mini Camera after they are installed. Consideration should be given to using a more rigid outlet pipe such as a schedule 40 PVC pipe for edge drain outlet pipes.

It is recommended that 203 mm to 254 mm (8 to 10 inches) of DGA be placed under the headwalls to increase foundation strength. Consideration should be given to redesigning the headwalls to more evenly distribute the mass and to provide the headwall with a built in slope. This would provide a more stable installation.

It is recommended that the headwall trough, screen, and ditch lines be inspected and cleaned at a minimum of twice a year.

It is recommended that current specifications for installation be continued.

REFERENCES

1. Jeffcoat, H. H.; Kilpatrick, F. A.; Atkins, J. B.; and Pearman, J. L.; "Effectiveness of Highway Edge Drains", US. Geological Survey, Water - Resources Investigation Report 92-4147, Reston, Virginia 1992.
2. Elsharief, Ahmed, M., "Laboratory Evaluation of Prefabricated Highway Edge Drains", Purdue University, and Indiana Department of Highways, FHWA/In/JHRP-92/20, 1992.
3. Frobel, Ronald K., "Eccentric (Angled) Loading of Prefabricated Highway Edge Drains", Transportation Research Record, No. 1329, "Geocomposite Pavement Drain Systems, 1991.
4. Stuart, E; Inouye, K. S.; and Mckean, J. A.; "Laboratory Procedure for Predicting Geocomposite Drain System Performance in the Field", Transportation Research Record No. 1329, "Geocomposite Pavement Drain Systems", 1991, Page No. 21.
5. Young, Brad., "Evaluation of the Performance of Fin Drains in Georgia," Georgia Department of Transportation, GDOT Research Project 8709, July 1991.
6. Allen, David L., "Analysis of Edge Drains on Western Kentucky Parkway, Milepost 83 to Milepost 90", Research Report KTC-89-46, Kentucky Transportation Center, September 1989.

FIGURE 1. PROFILE OF EDGE DRAINS TESTED

**TYPE A
(AKWADRAIN)**

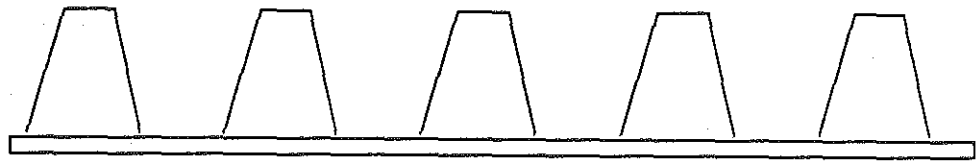

**TYPE B
(CONTECH)**

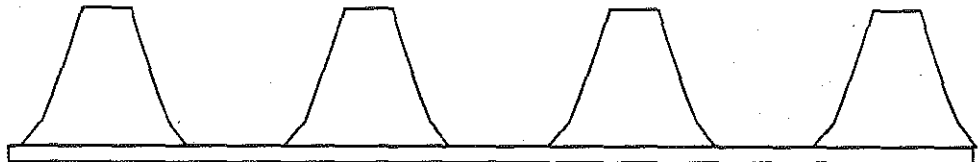

**TYPE C
(PRODRAIN)**

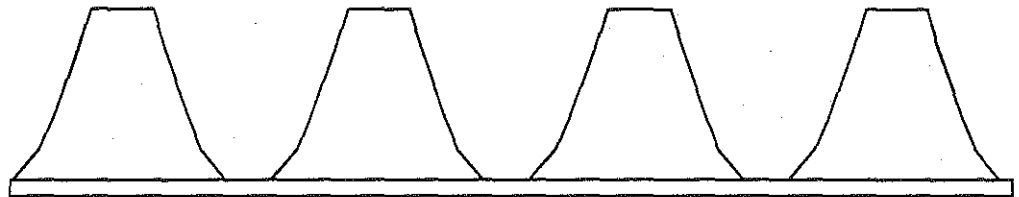

**TYPE D
(HYDRAWAY)**

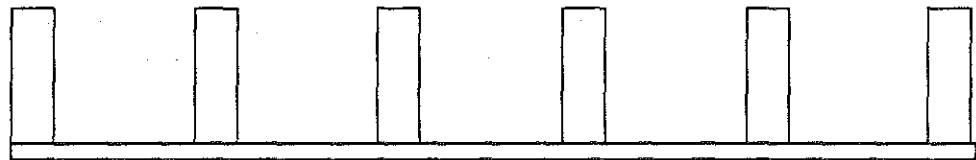

**TYPE E
(ADVANEDGE)**

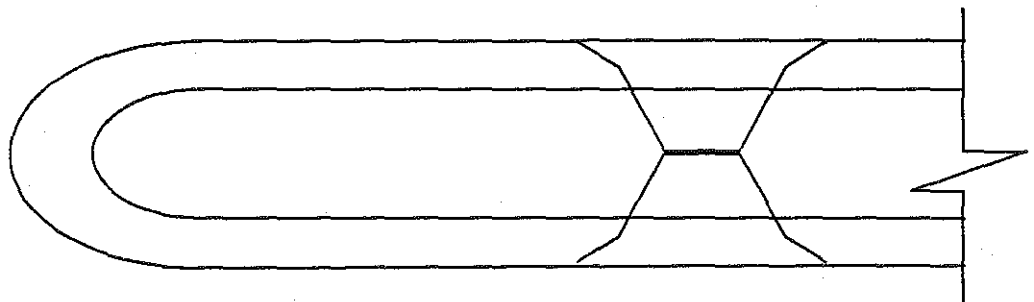

**TYPE F
(SUPAC)**

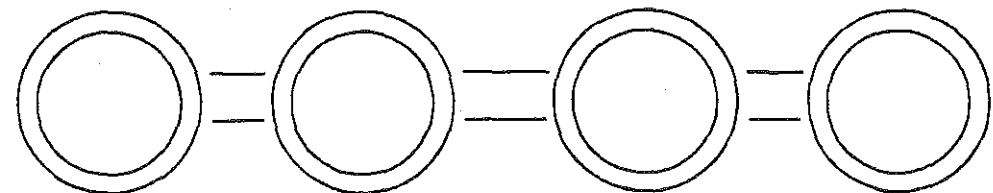

TABLE 1. HEADWALL INSPECTION, MOUNTAIN PARKWAY

LOCATION-->	MP 6-25 SB AND NB MOUNTAIN
# CLEAN % CLEAN	19 38 %
# PARTIALLY COVERED % PARTIALLY COVERED	14 29 %
# COVERED % COVERED	13 27 %
# PLUGGED % PLUGGED	3 - 16 6 % - 33 %
TOTAL	49

TABLE 2. HEADWALL INSPECTION, INTERSTATE 64

LOCATION-->	MP 56-59 EB AND WB I-64	MP 112-132 EB, I-64	MP 82-89 WB, I-64	TOTAL
# CLEAN % CLEAN	27 60 %	26 50 %	21 81 %	74 60 %
# PARTIALLY COVERED % PARTIALLY COVERED	13 29 %	17 33 %	4 15 %	34 28 %
# COVERED % COVERED	5 11 %	7 13 %	0 0 %	12 10 %
# PLUGGED % PLUGGED	0 - 5 0 % - 11 %	2 - 9 4 % - 17 %	1 4 %	3 - 15 2 % - 12%
TOTAL	45	52	26	123

TABLE 3. HEADWALL INSPECTION, INTERSTATE 75.

LOCATION-->	MP 28-48 SB AND NB I-75	MP 3-28 SB AND NB I-75	TOTAL
# CLEAN % CLEAN	34 92 %	4 14 %	38 57 %
# PARTIALLY COVERED % PARTIALLY COVERED	3 8 %	10 33 %	13 19 %
# COVERED % COVERED	0 0 %	13 43 %	13 19 %
# PLUGGED % PLUGGED	0 0 %	3 - 16 10 - 53 %	3 - 16 5 % - 24 %
TOTAL	37	30	67

TABLE 4. HEADWALL INSPECTION (AVERAGE OF MOUNTAIN PARKWAY, I-64, and I-75).

LOCATION-->	TOTAL MOUNTAIN	TOTAL I-64	TOTAL I-75	TOTAL
# CLEAN % CLEAN	19 38 %	74 60 %	38 57 %	131 55 %
# PARTIALLY COVERED % PARTIALLY COVERED	14 29 %	34 28 %	13 19 %	61 26 %
# COVERED % COVERED	13 27 %	12 10 %	13 19 %	38 16 %
# PLUGGED % PLUGGED	3 - 16 6 % - 33 %	3 - 15 2 % - 12 %	3 - 16 5 % - 24 %	9 - 47 4 % - 20 %
TOTAL	49	123	67	239

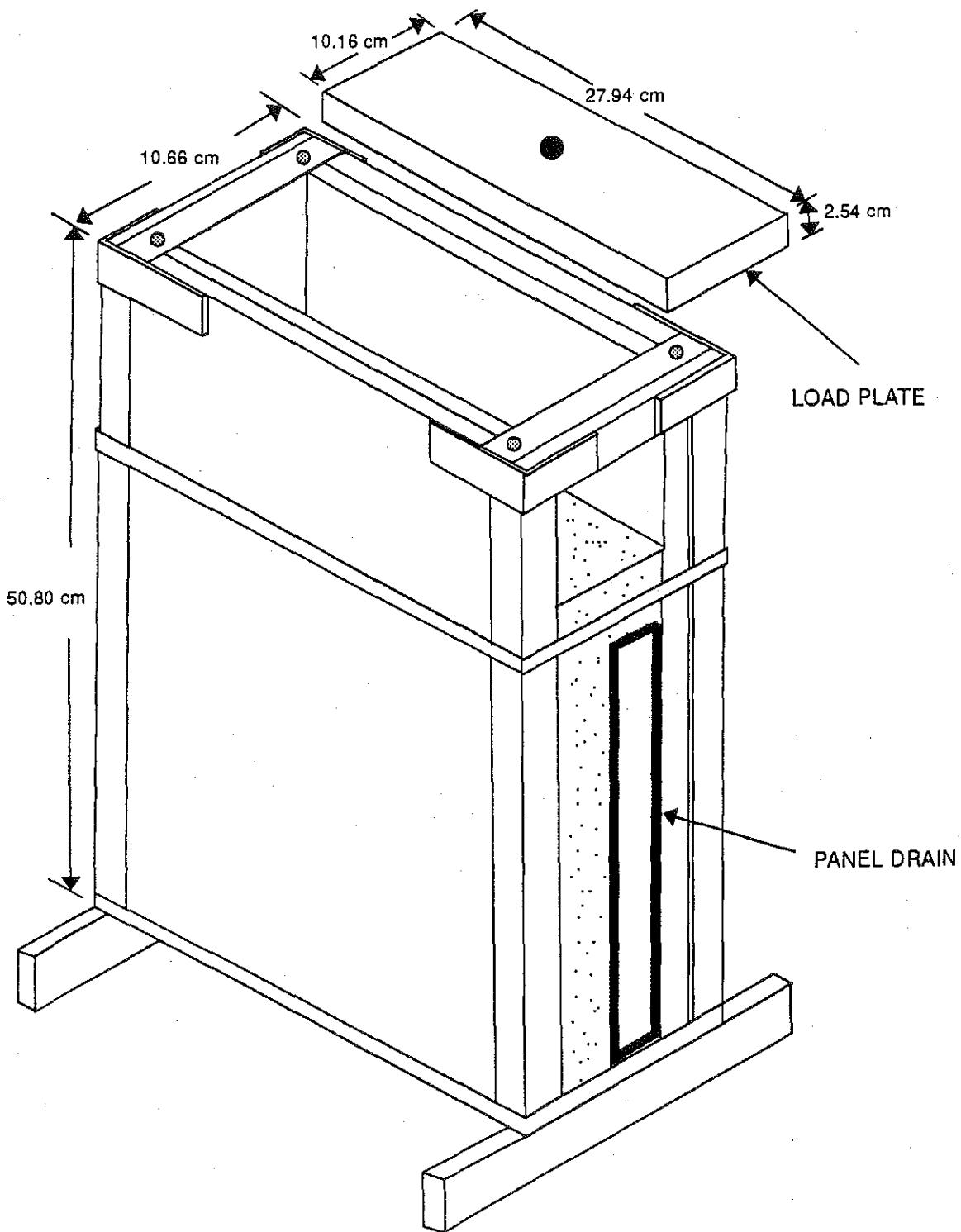

FIGURE 2. EDGE DRAIN COMPRESSION CHAMBER

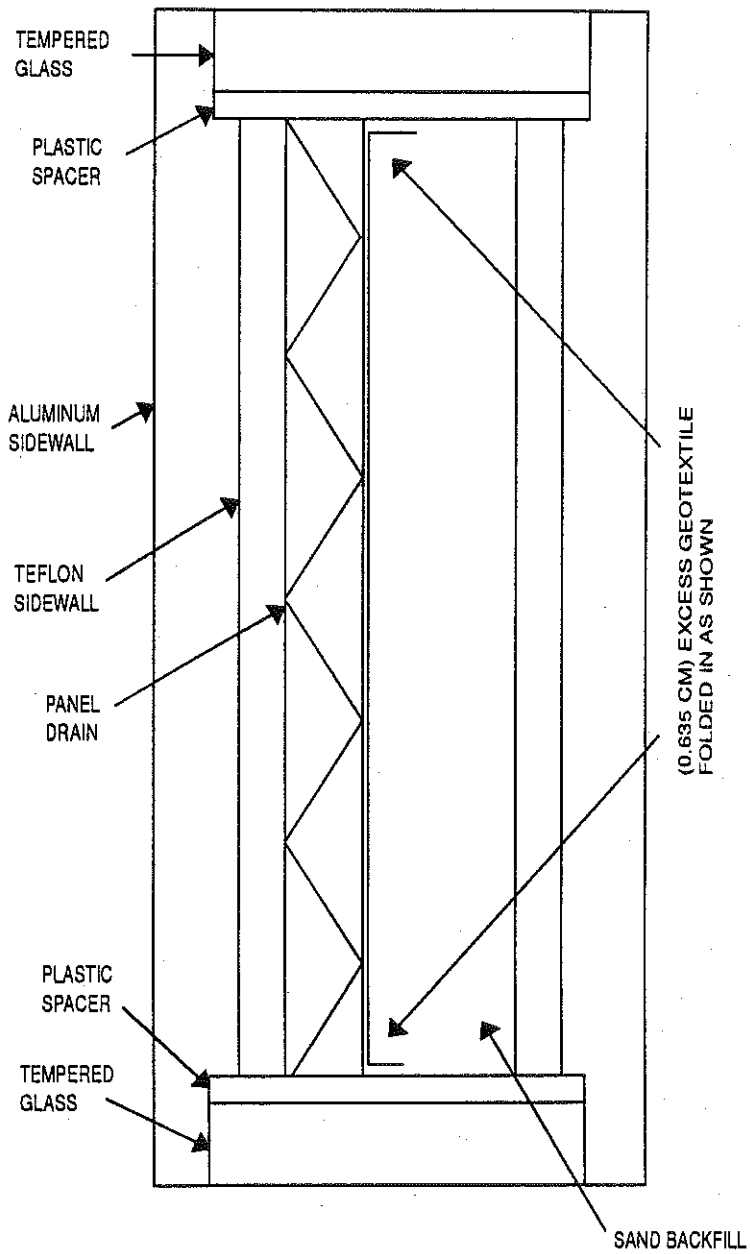
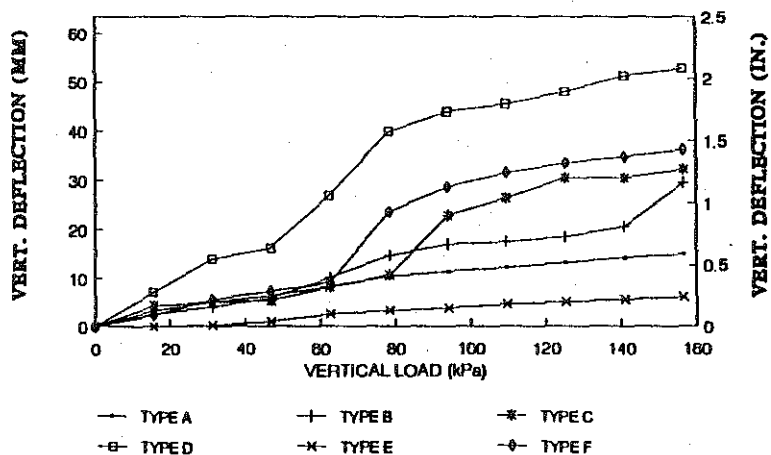

FIGURE 3. TOP VIEW OF COMPRESSION CHAMBER

FIGURE 4. VERTICAL COMPRESSION (SERIES 1-4)

SERIES 1. VERTICAL COMPRESSION
(SAND BACKFILL, LOOSE)



SERIES 2. VERTICAL COMPRESSION
(SAND BACKFILL, DENSE)

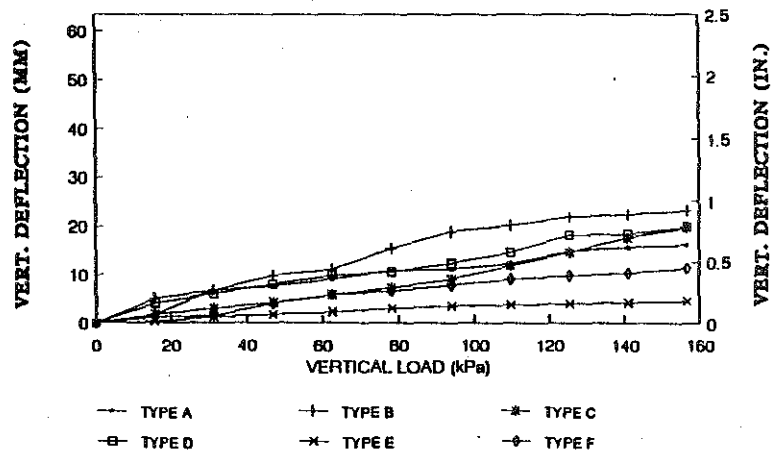

SERIES 3. VERTICAL COMPRESSION
(SAND LOOSE, PANELS BACKWARDS)

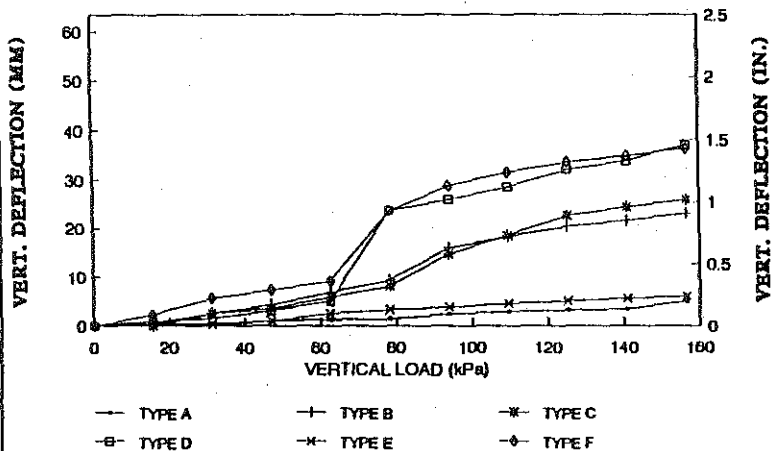

SERIES 4. VERTICAL COMPRESSION
(SAND DENSE, PANELS BACKWARDS)

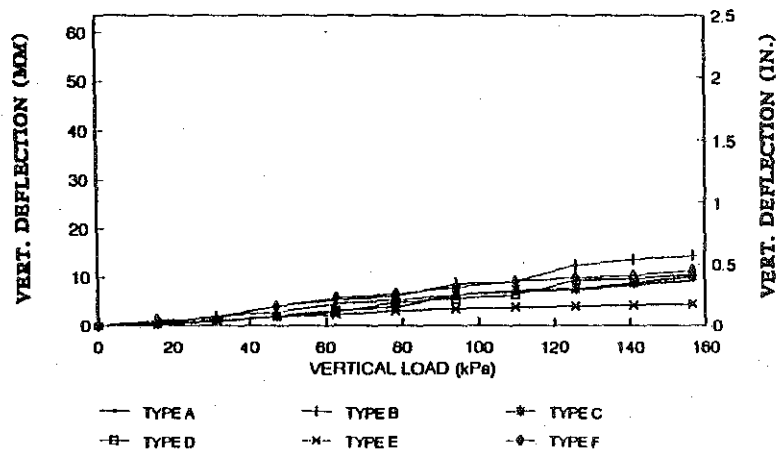

(160.0 kPa = 23.20 psi)

TABLE 5. PERCENT VERTICAL COMPRESSION AT 156.5 kPa

VERTICAL EDGE DRAIN COMPRESSION TEST (PERCENT VERTICAL COMPRESSION AT 156.5 kPa (22.7 PSI))	OPEN SIDE OF PANEL FACING SAND BACKFILL		RIGID BACK SIDE OF PANEL FACING SAND BACKFILL	
	PANEL TYPE	SERIES 1. BACKFILL LOOSE	SERIES 2. BACKFILL DENSE	SERIES 3. BACKFILL LOOSE
TYPE A	4.9%	5.3%	1.6%	3.1%
TYPE B	10.2%	8.1%	8.0%	5.0%
TYPE C	10.0%	6.5%	8.5%	3.3%
TYPE D	16.8%	6.5%	12.0%	3.5%
TYPE E	1.92%	1.4%	1.92%	1.4%
TYPE F	11.7%	3.7%	11.7%	3.7%

*Type E and Type F are solid cores and are identical on both sides of the panel. The data is contained in series 3 and 4 comparison.

TABLE 6. CHANGE IN CORE CAPACITY (OPEN SIDE OF PANEL FACING SAND)

VERTICAL EDGE DRAIN COMPRESSION TEST (CHANGE IN CORE CAPACITY)		OPEN SIDE OF PANEL FACING SAND BACKFILL									
		SERIES 1. SAND BACKFILL LOOSE					SERIES 2. SAND BACKFILL DENSE				
PANEL TYPE	VERTICAL LOAD kPa>>	0	39.2	78.3	117.2	156.5	0	39.2	78.3	117.2	156.5
TYPE A	PERCENT CHANGE IN CORE CAPACITY>>	0	-12.7	-19.5	-26.2	-27.4	0	-7.0	-8.4	-18.3	-25.9
TYPE B		0	-12.3	-26.5	-30.2	-35.0	0	-13.3	-21.6	-29.6	-33.7
TYPE C		0	-8.4	-21.9	-40.4	-52.0	0	-4.7	-13.6	-24.5	-33.4
TYPE D		0	-3.6	-40.7	-50.4	-57.6	0	-5.9	-11.4	-19.6	-25.7
TYPE E		0	+2.2	+1.3	+0.6	+2.1	0	0	+1.1	+1.1	+1.1
TYPE F		0	-0.2	0	+0.2	-2.46	0	-4.1	-3.7	-3.1	-4.1

FIGURE 5. CHANGE IN CORE CAPACITY (SERIES 1-4)

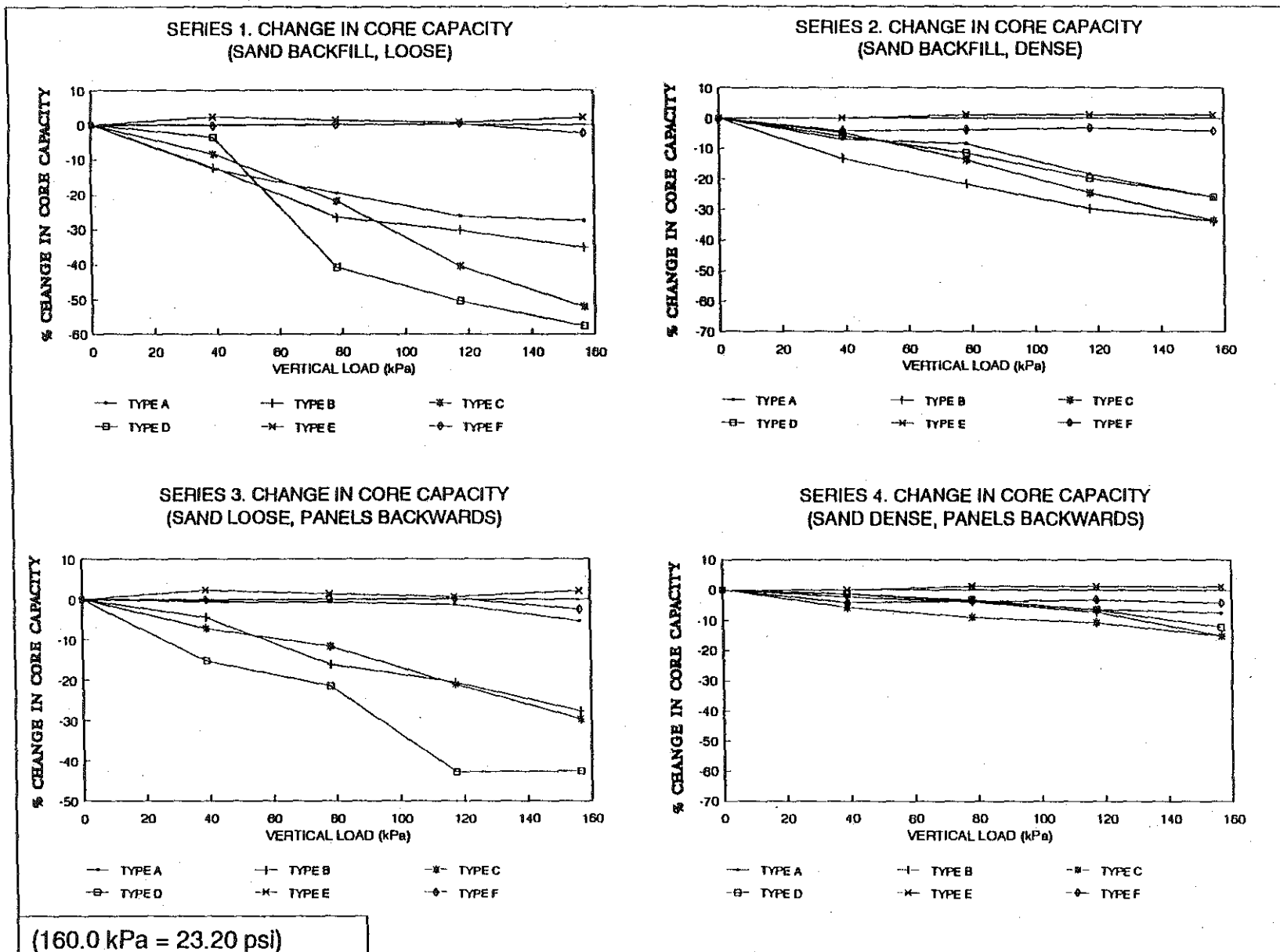

FIGURE 6. CORE CAPACITY (SERIES 1-4)

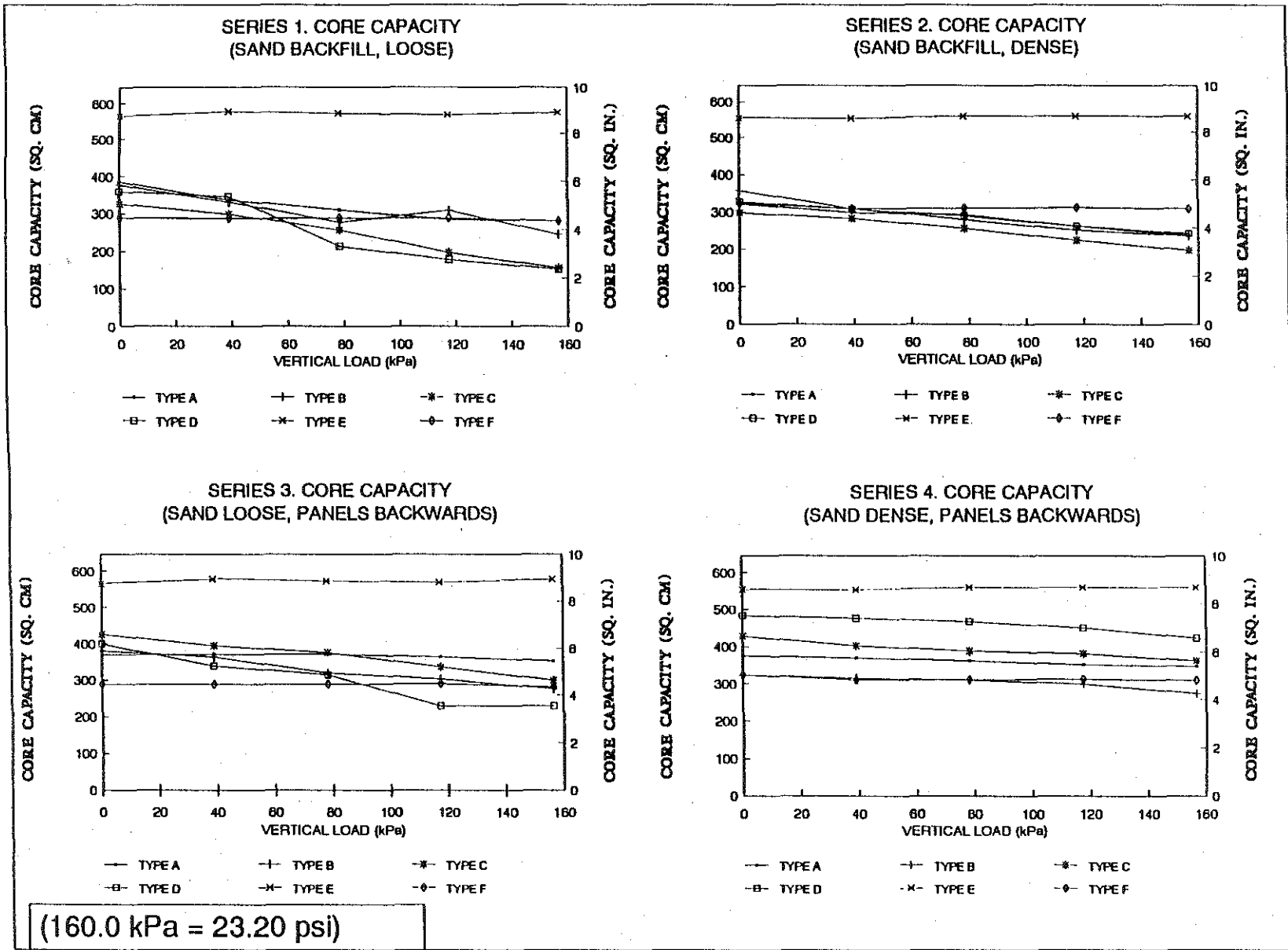

TABLE 7. CORE CAPACITY IN SQUARE CENTIMETERS AT 0 kPa AND 156.5 kPa

VERTICAL EDGE DRAIN DRAIN COMPRESSION TEST (CORE CAPACITY AT 0 & 156.5 kPa)	OPEN SIDE OF PANEL FACING SAND BACKFILL				RIGID BACK SIDE OF PANEL FACING SAND BACKFILL			
	SERIES 1. BACKFILL LOOSE		SERIES 2. BACKFILL DENSE		SERIES 3. BACKFILL LOOSE		SERIES 4. BACKFILL DENSE	
	0 kPa	156.5 kPa	0 kPa	156.5 kPa	0 kPa	156.5 kPa	0 kPa	156.5 kPa
TYPE A	385.8	279.9	321.2	238.1	369.0	349.0	375.5	347.1
TYPE B	377.4	245.2	357.4	236.7	380.6	275.5	322.6	274.2
TYPE C	325.8	156.1	297.4	198.1	425.2	298.7	427.7	362.6
TYPE D	359.3	152.2	327.7	243.2	399.3	229.0	482.6	423.8
TYPE E	564.5	576.7	570.9	560.0	564.5	576.7	553.5	560.0
TYPE F	288.4	281.3	323.2	309.6	288.4	281.3	323.2	309.7

TABLE 8. CHANGE IN CORE CAPACITY (RIGID BACK SIDE OF PANEL FACING SAND)

VERTICAL EDGE DRAIN COMPRESSION TEST (CHANGE IN CORE CAPACITY)		RIGID BACK SIDE OF PANEL FACING SAND BACKFILL									
		SERIES 3. SAND BACKFILL LOOSE					SERIES 4. SAND BACKFILL DENSE				
PANEL TYPE	VERTICAL LOAD kPa>>	0	39.2	78.3	117.2	156.5	0	39.2	78.3	117.2	156.5
TYPE A	PERCENT CHANGE IN CORE CAPACITY>>	0	+0.7	+0.7	-1.3	-5.3	0	-1.5	-3.6	-6.3	-7.5
TYPE B		0	-4.5	-16.1	-20.5	-27.6	0	-2.4	-4.0	-7.2	-15.0
TYPE C		0	-7.2	-11.6	-21.0	-29.6	0	-5.8	-9.0	-10.7	-15.2
TYPE D		0	-15.3	-21.4	-42.8	-42.6	0	-1.3	-3.2	-6.5	-12.1
TYPE E		0	+2.2	+1.3	+0.6	+2.1	0	0	+1.1	+1.1	+1.1
TYPE F		0	-0.2	0	+0.2	-2.46	0	-4.1	-3.7	-3.1	-4.1

FIGURE 7. FLAT PARALLEL PLATE TEST
10% STRAIN

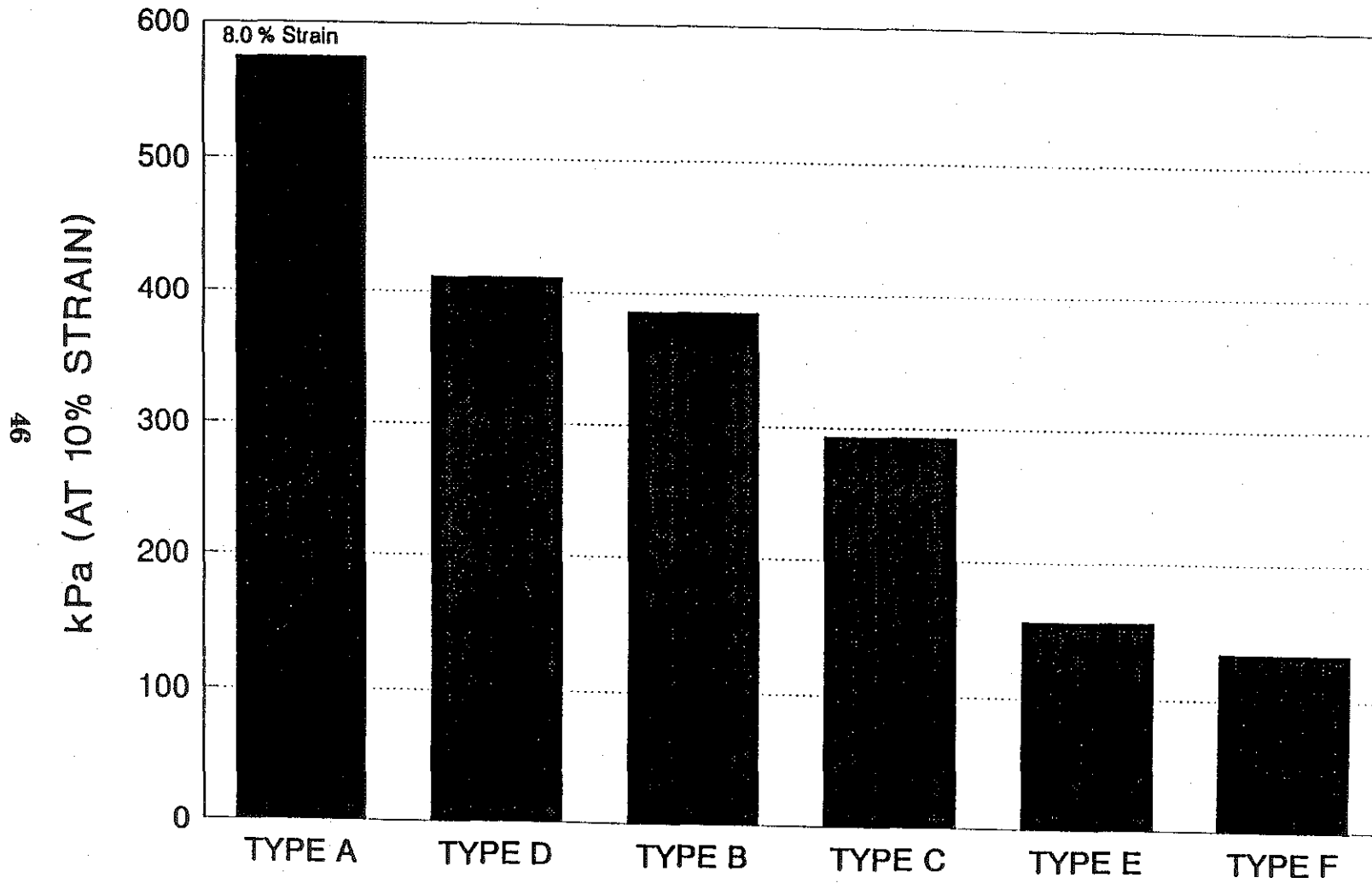
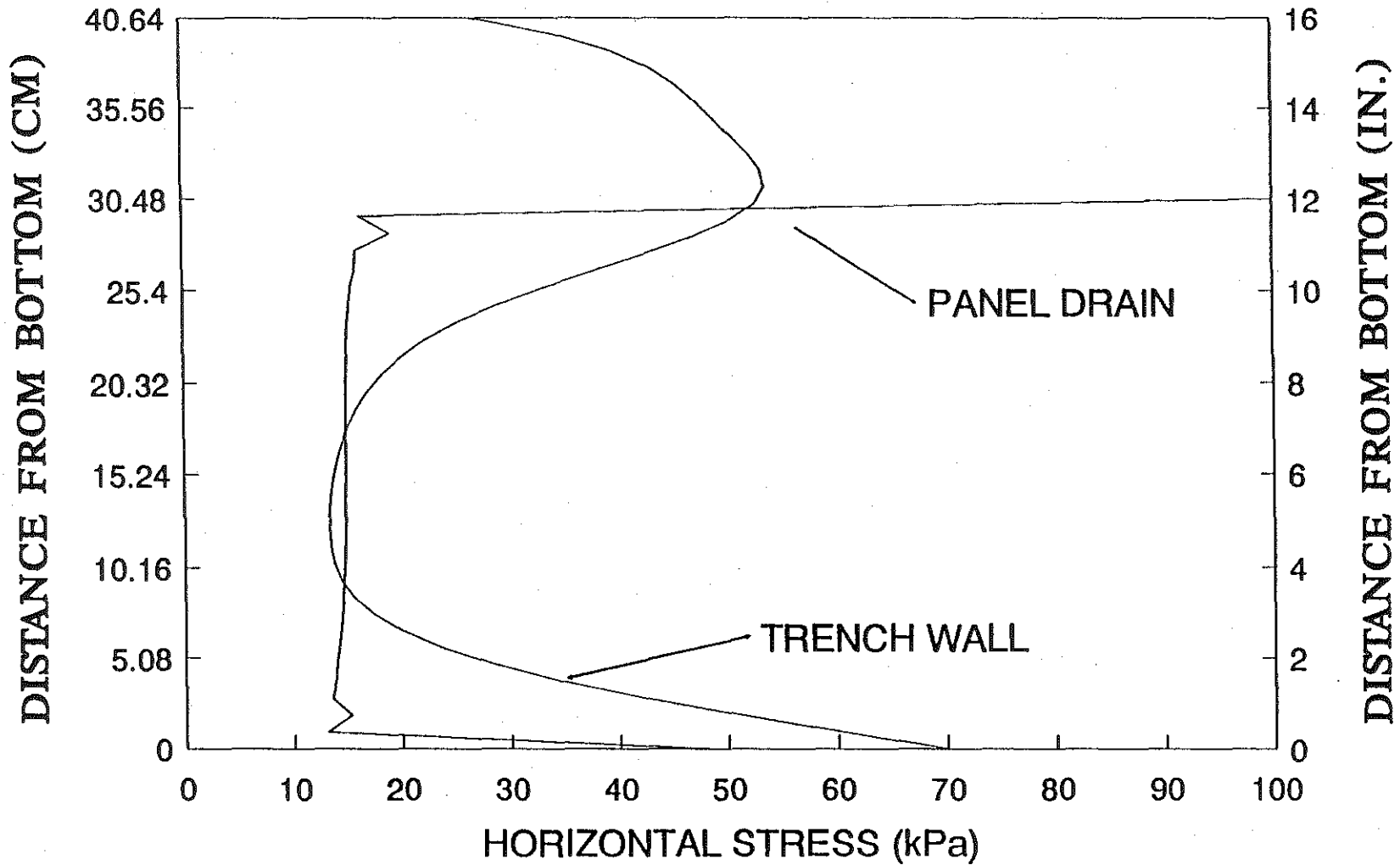

FIGURE 8. FINITE ELEMENT MODELING
STRESS INTRODUCED AT PANEL



VERTICAL PRESSURE = 156.71 kPa

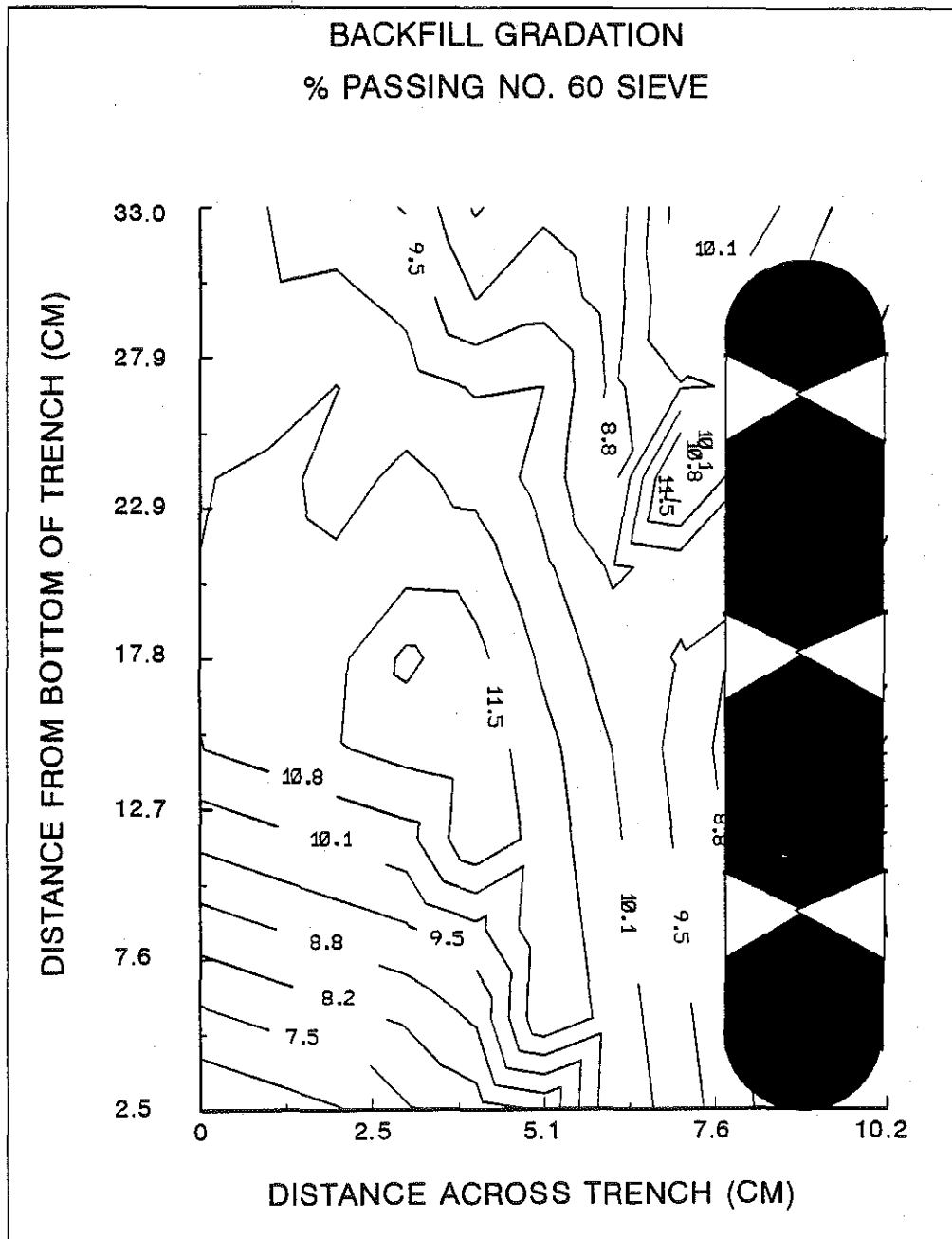
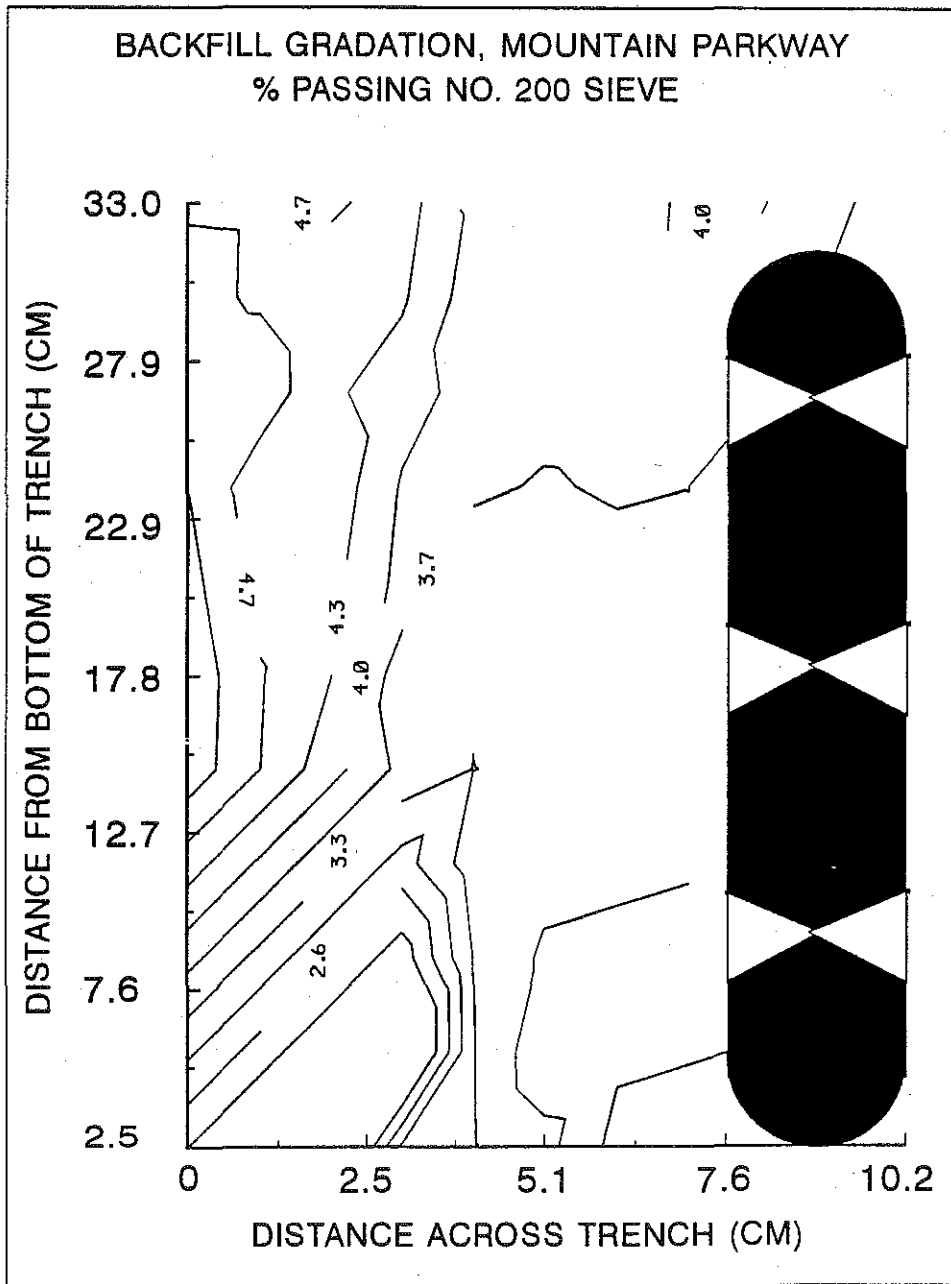

FIGURE 9. BACKFILL GRADATION, MOUNTAIN PARKWAY
(% PASSING NO. 60 SIEVE).



**FIGURE 10. BACKFILL GRADATION, MOUNTAIN PARKWAY
(% PASSING NO. 200 SIEVE).**

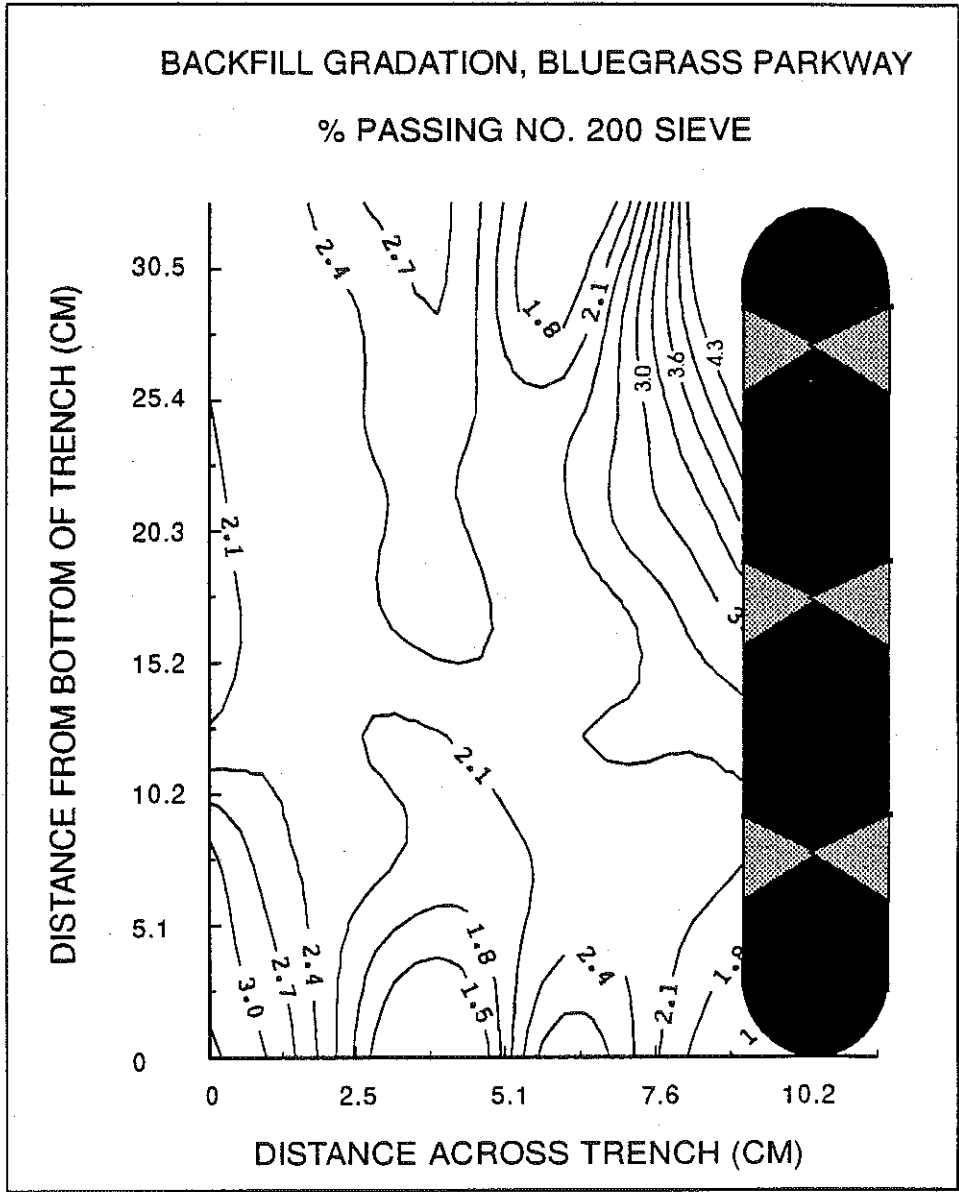

FIGURE 11. BACKFILL GRADATION, BLUEGRASS PARKWAY, M.P. 57)
(% PASSING NO. 200 SIEVE).

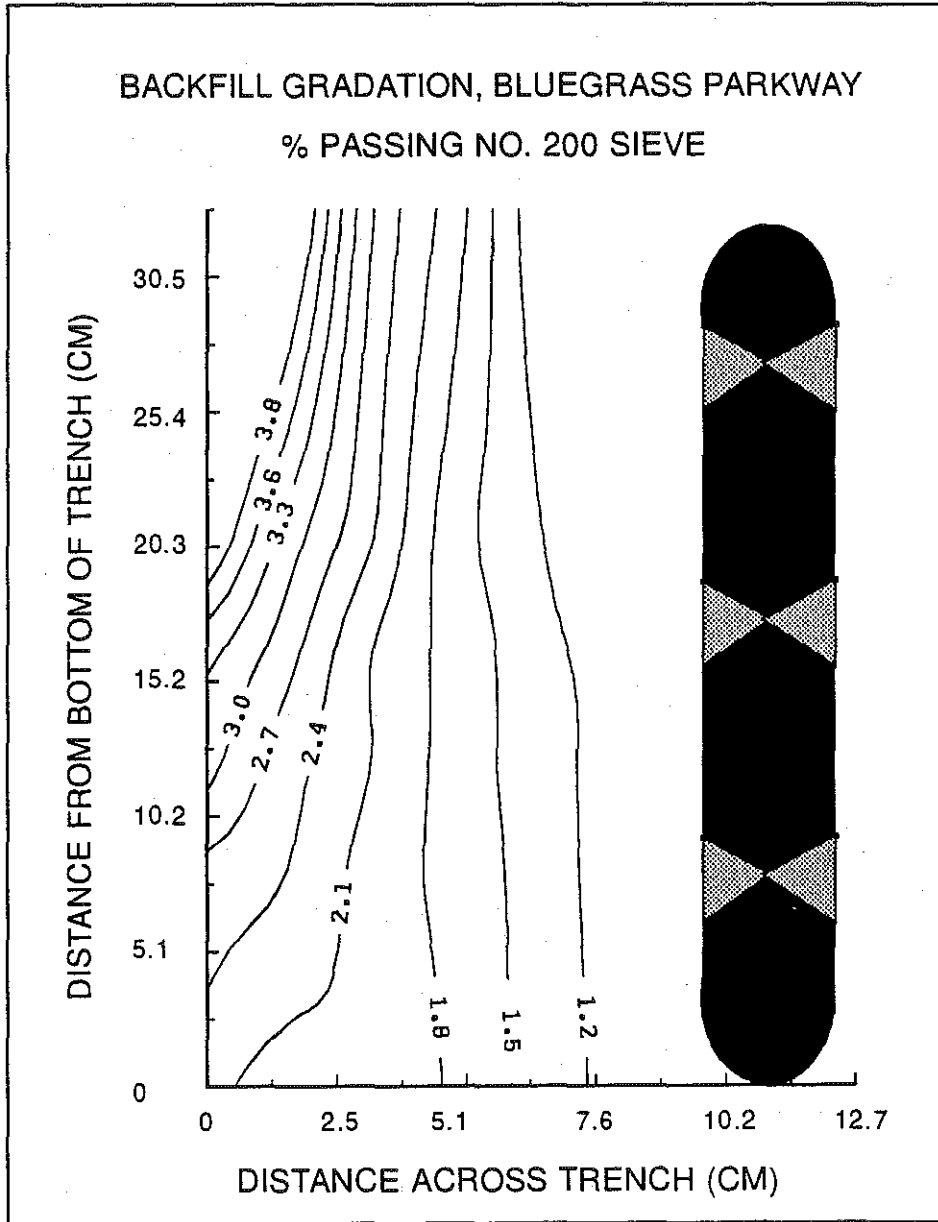

FIGURE 12. BACKFILL GRADATION, BLUEGRASS PARKWAY, M.P. 34)
(% PASSING NO. 200 SIEVE).

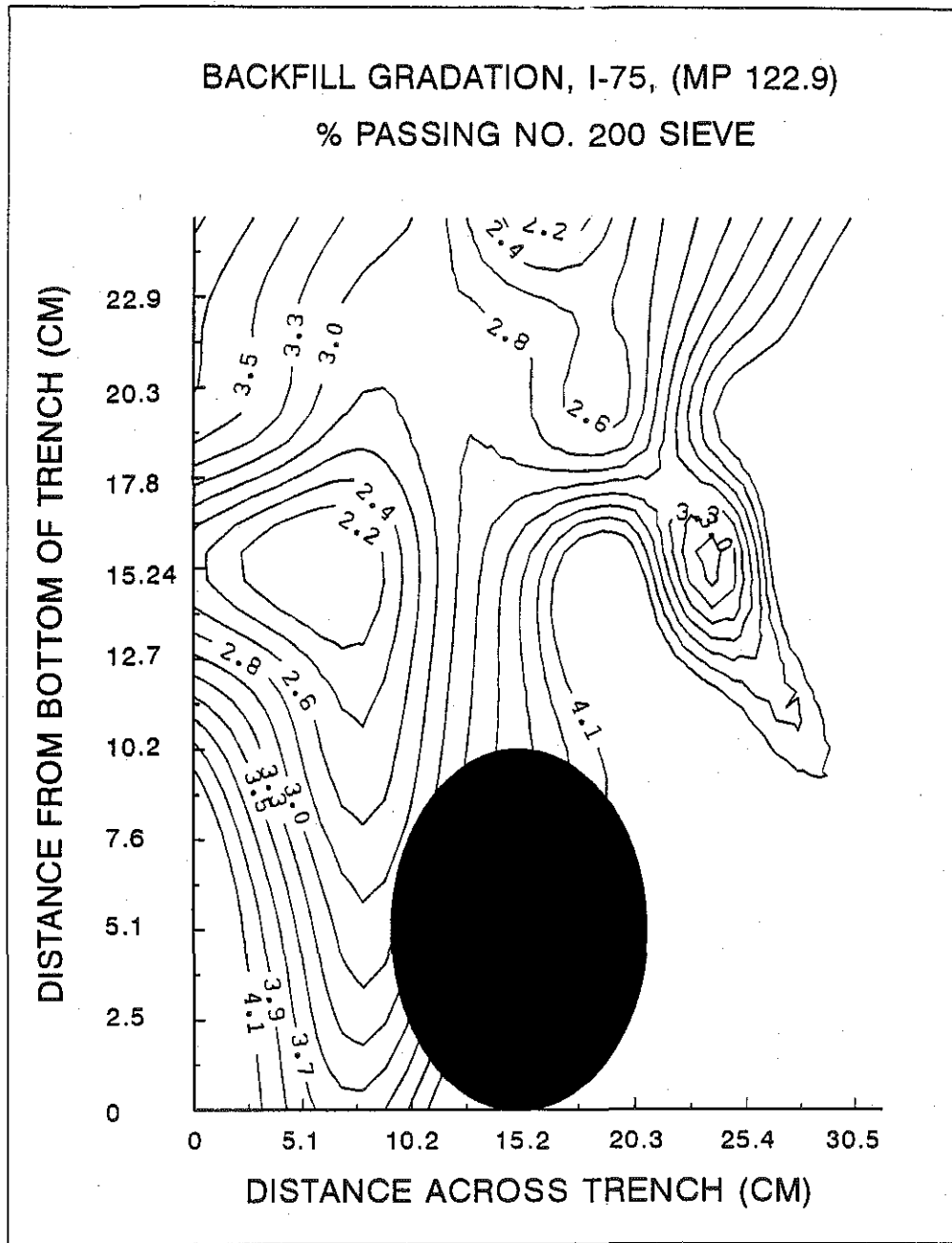

FIGURE 13. BACKFILL GRADATION, INTERSTATE 75, M.P. 122.9)
(% PASSING NO. 200 SIEVE).



FIGURE 14: FILTER FABRIC AROUND ADS PANEL
(BACKFILLED WITH SAND)



FIGURE 15: FILTER FABRIC AROUND ADS PANEL
(BACKFILLED WITH EXCAVATED MATERIAL)

Cursor: 0.000keV = 0

55

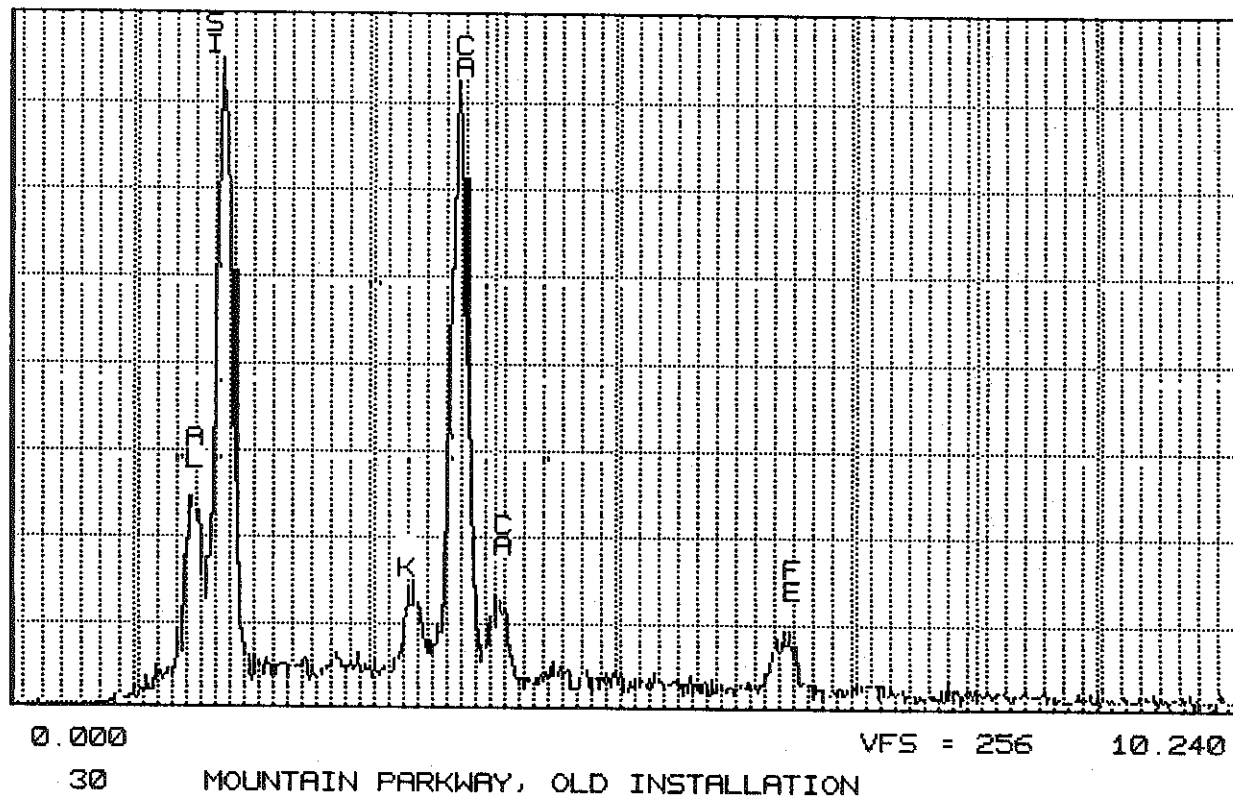

FIGURE 16. ELECTRON MICROSCOPE SCAN OF SEDIMENTS.

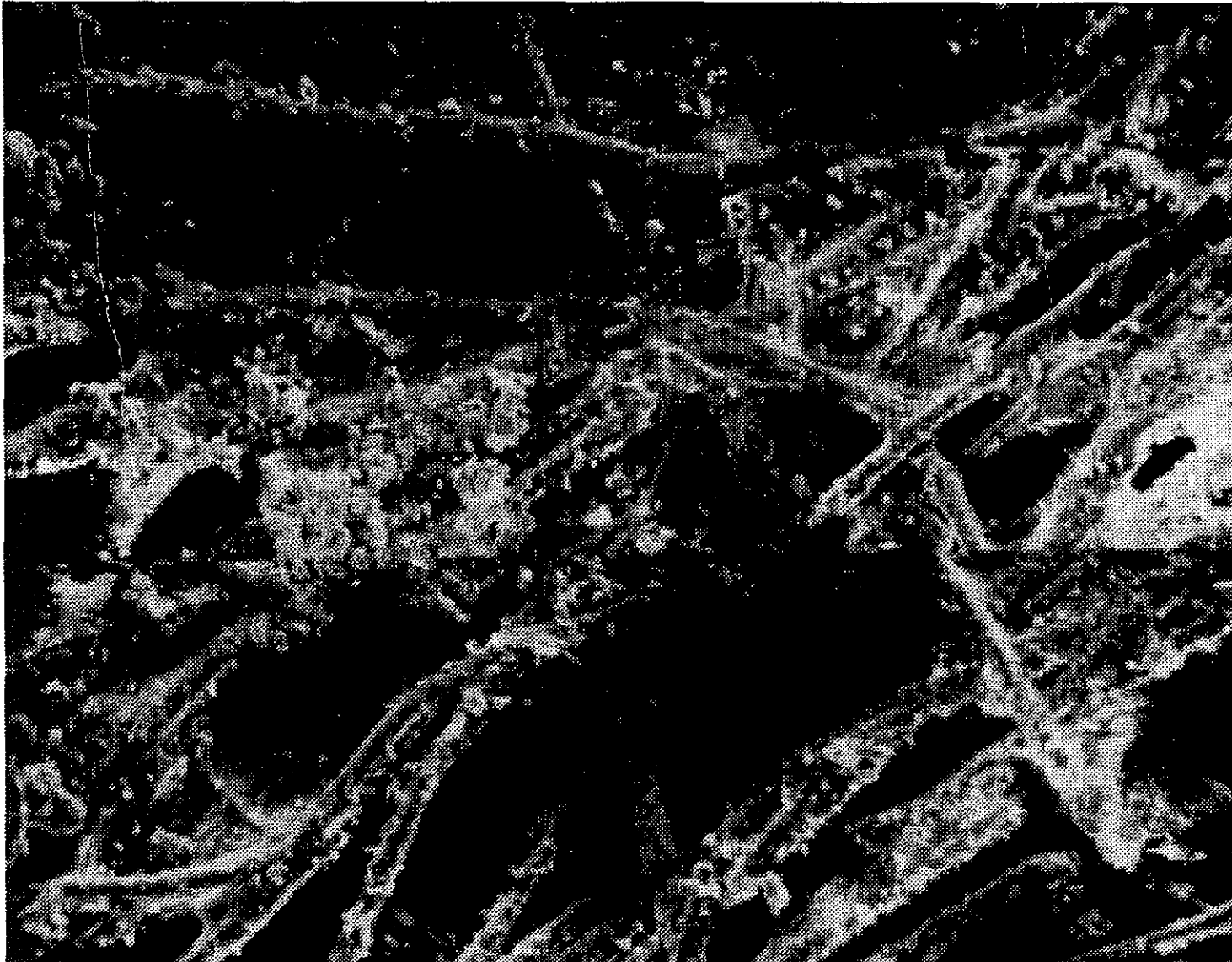

FIGURE 17: FILTER FABRIC FROM I-75 AND I-64 INTERCHANGE
(FABRIC WRAPPED TRENCH) TACK COAT ON FABRIC

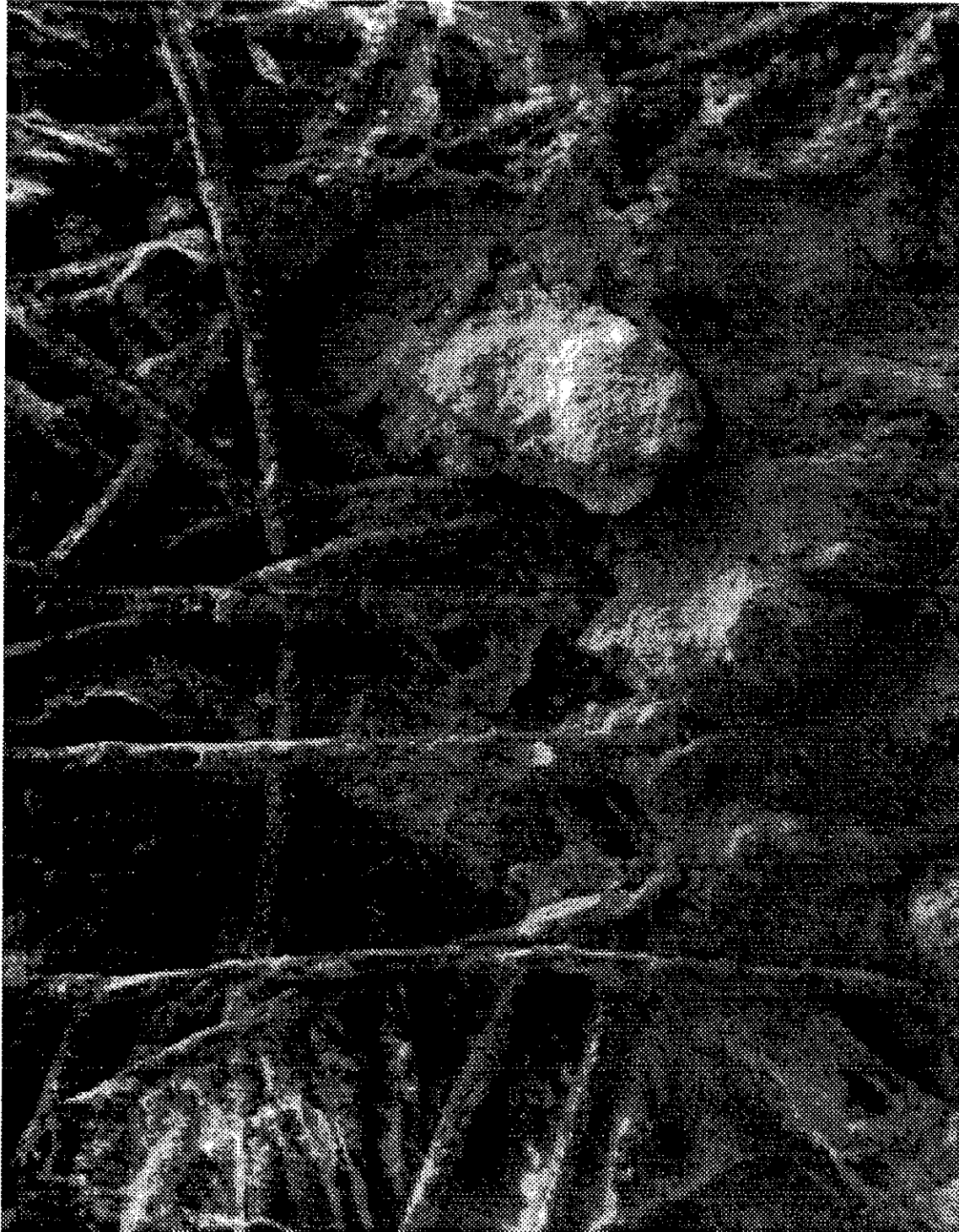
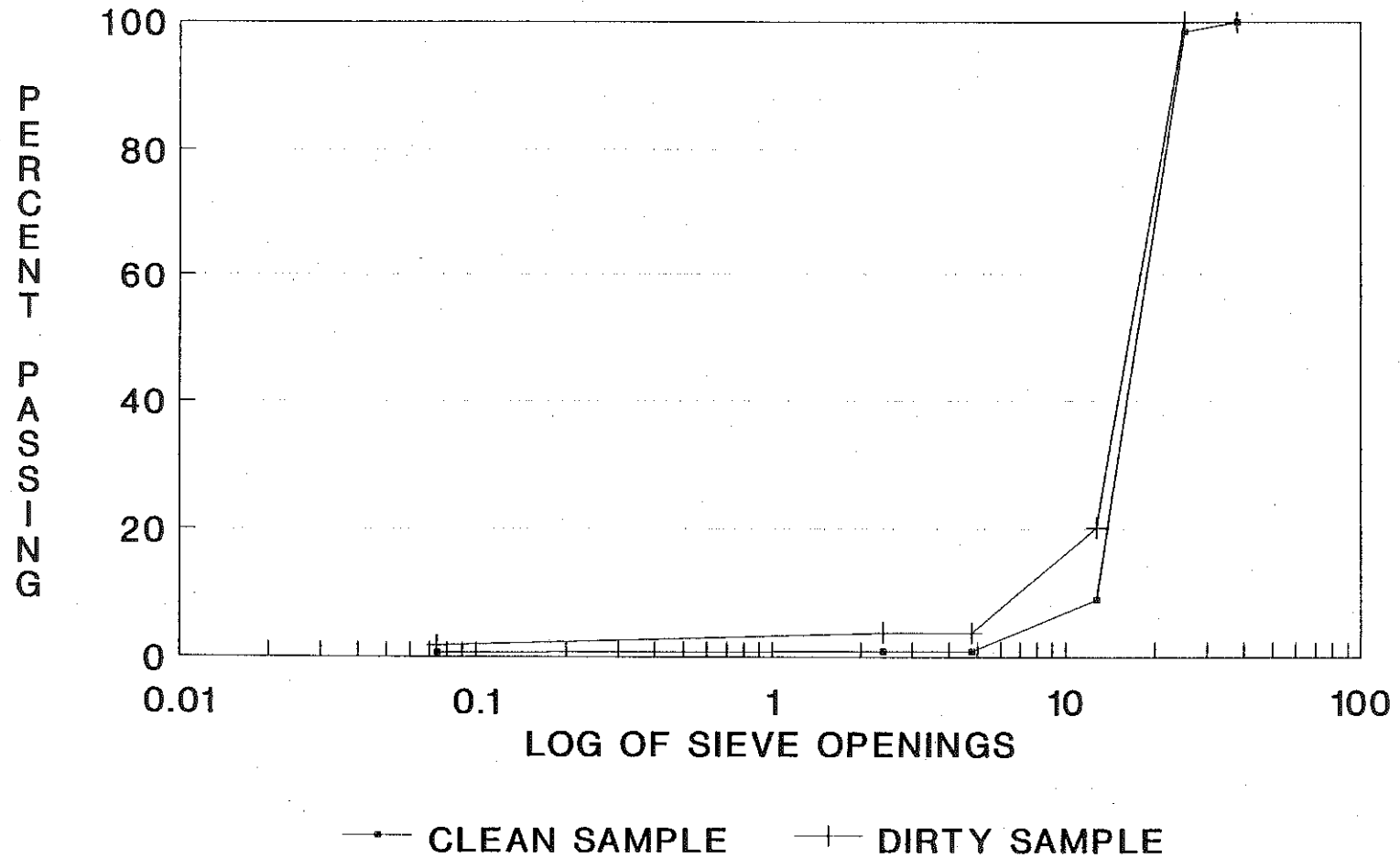

FIGURE 18: FILTER FABRIC FROM I-75 AND I-64 INTERCHANGE
(FABRIC WRAPPED TRENCH)

FIGURE 19. SAMPLE OF AGGREGATE FROM I-64 AND I-75 INTERCHANGE



Normalized Subgrade Moisture (All Sites)

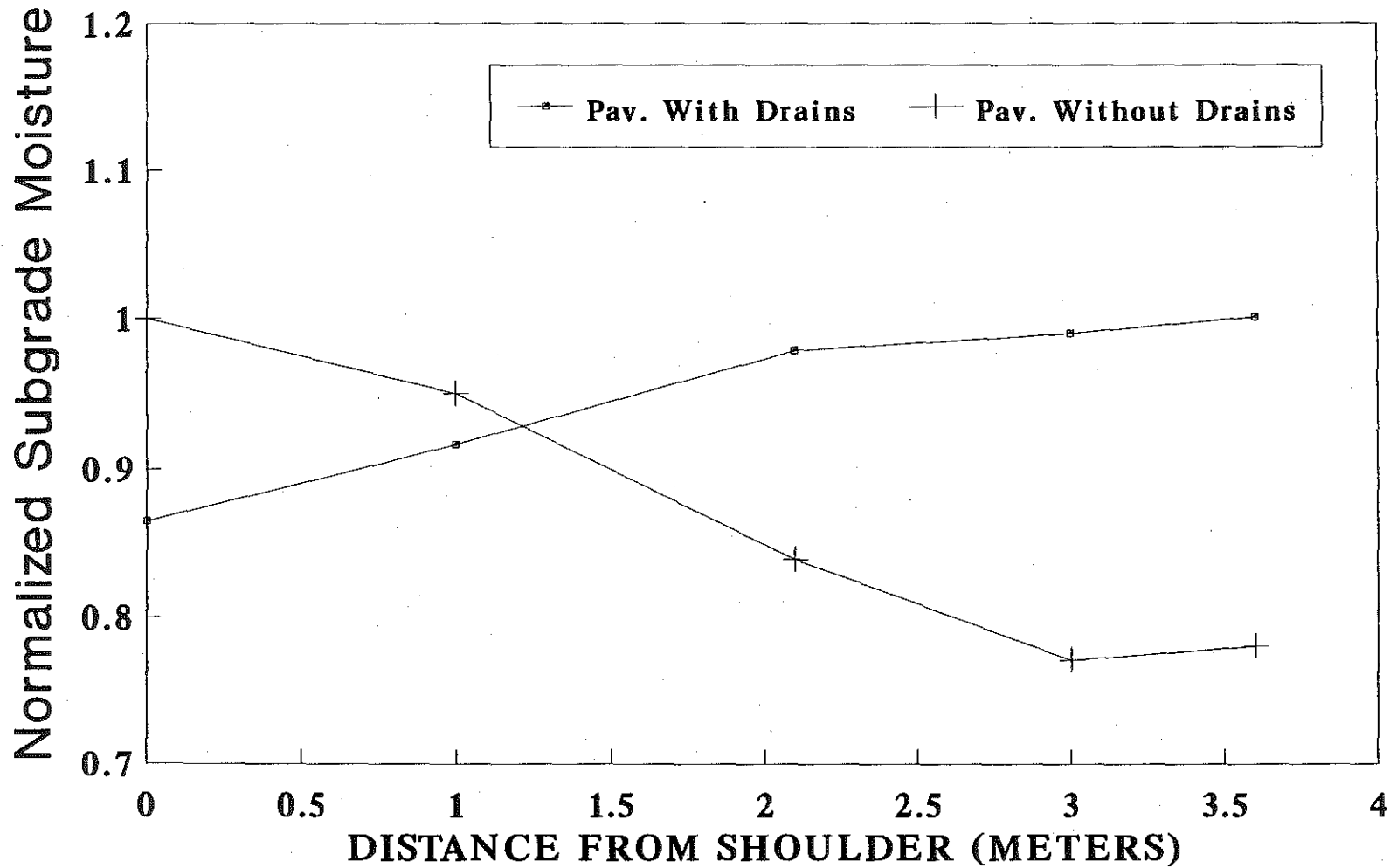

FIGURE 20. NORMALIZED SUBGRADE MOISTURE.

Normalized Subgrade Moisture (All Sites)

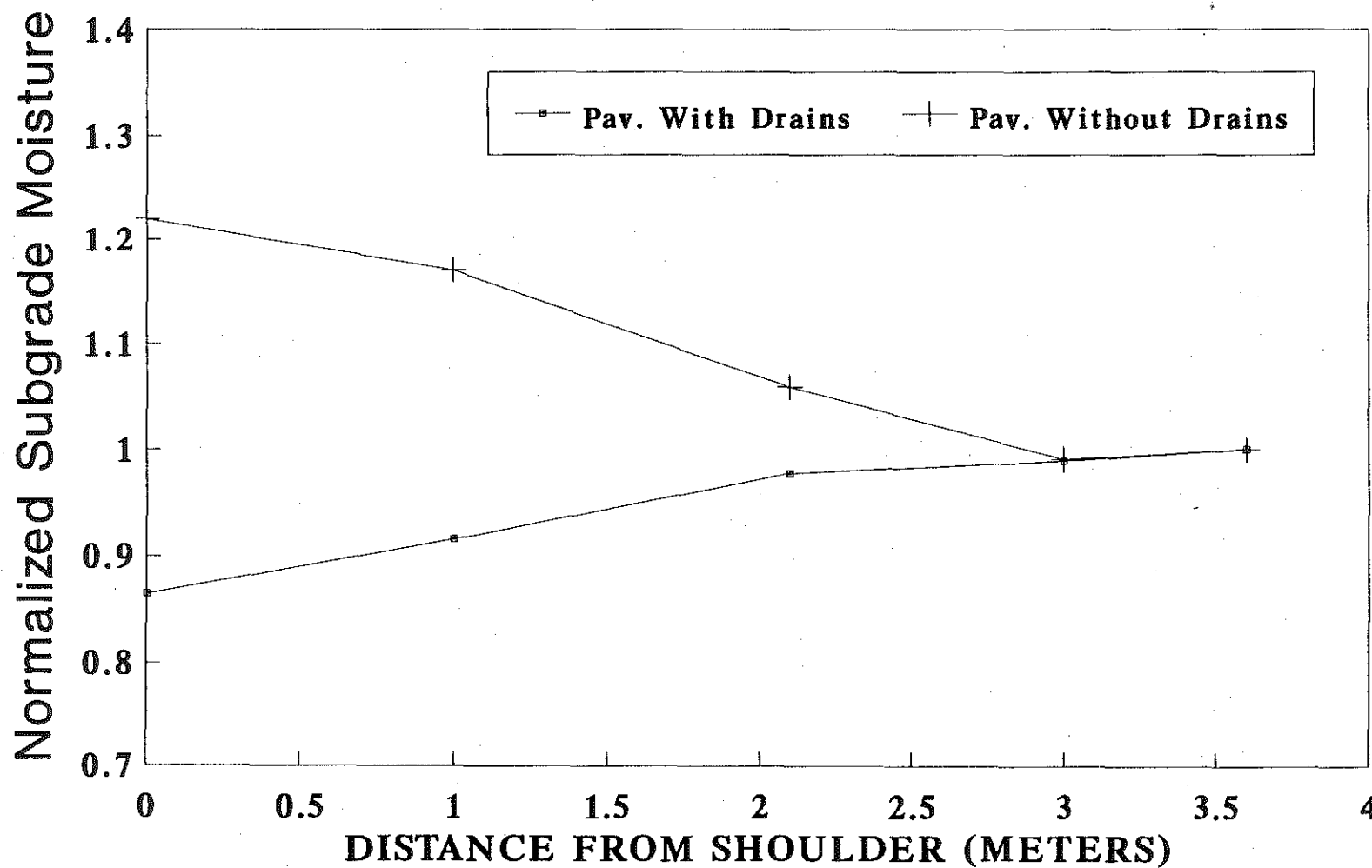
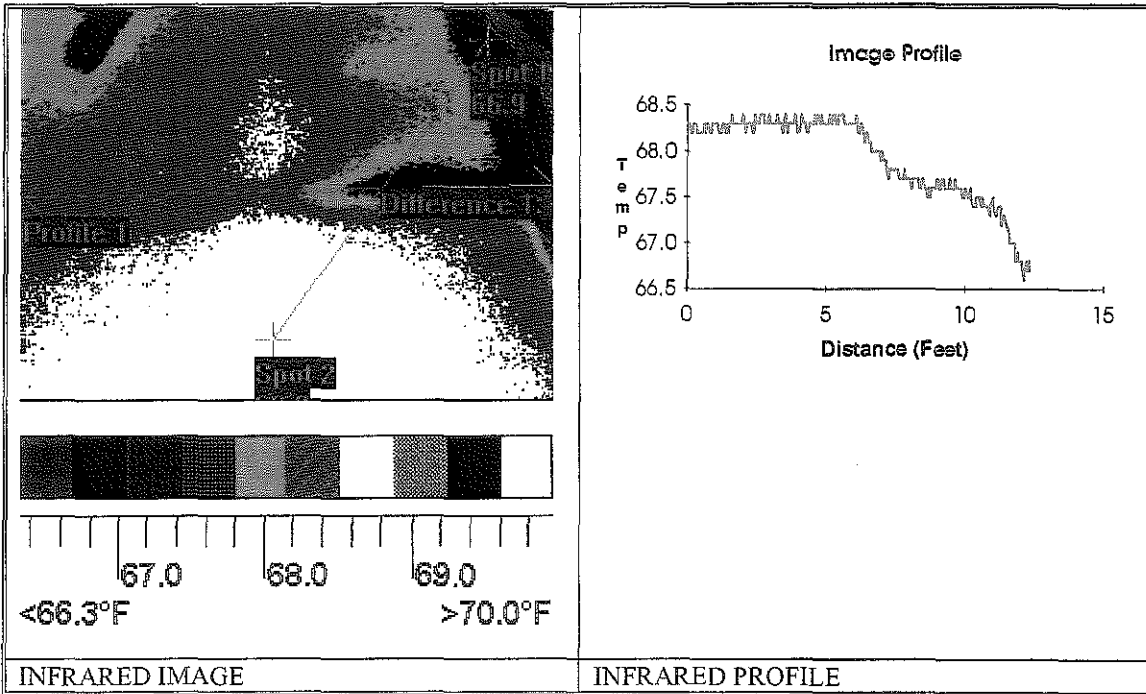

FIGURE 21. MODIFIED NORMALIZED SUBGRADE MOISTURE.

KENTUCKY TRANSPORTATION CENTER

THERMOGRAPHIC INSPECTION REPORT

ROUTE	BLUEGRASS PARKWAY
MILEPOST	36.0
DIRECTION	WEST BOUND
LANE	OUTSIDE
DRAINAGE TYPE	NON
DATE	09/24/1993
TIME	10:22:05 AM



THERMAL IMAGE DATA

IMAGE NAME	A:\16.TIF
MINIMUM TEMPERATURE	66.9
MAXIMUM TEMPERATURE	68.8
TEMPERATURE DIFFERENCE	-1.9
TEMPERATURE UNITS	F

FIGURE 22. THERMOGRAPHIC INSPECTION OF BLUEGRASS PARKWAY (M.P. 36.0).

KENTUCKY TRANSPORTATION CENTER

THERMOGRAPHIC INSPECTION REPORT

ROUTE	BLUEGRASS PARKWAY
MILEPOST	34.4
DIRECTION	WEST
LANE	OUTSIDE
DRAINAGE TYPE	ADVANEDGE PANEL DRAIN
DATE	09/24/1993
TIME	10:38:07 AM

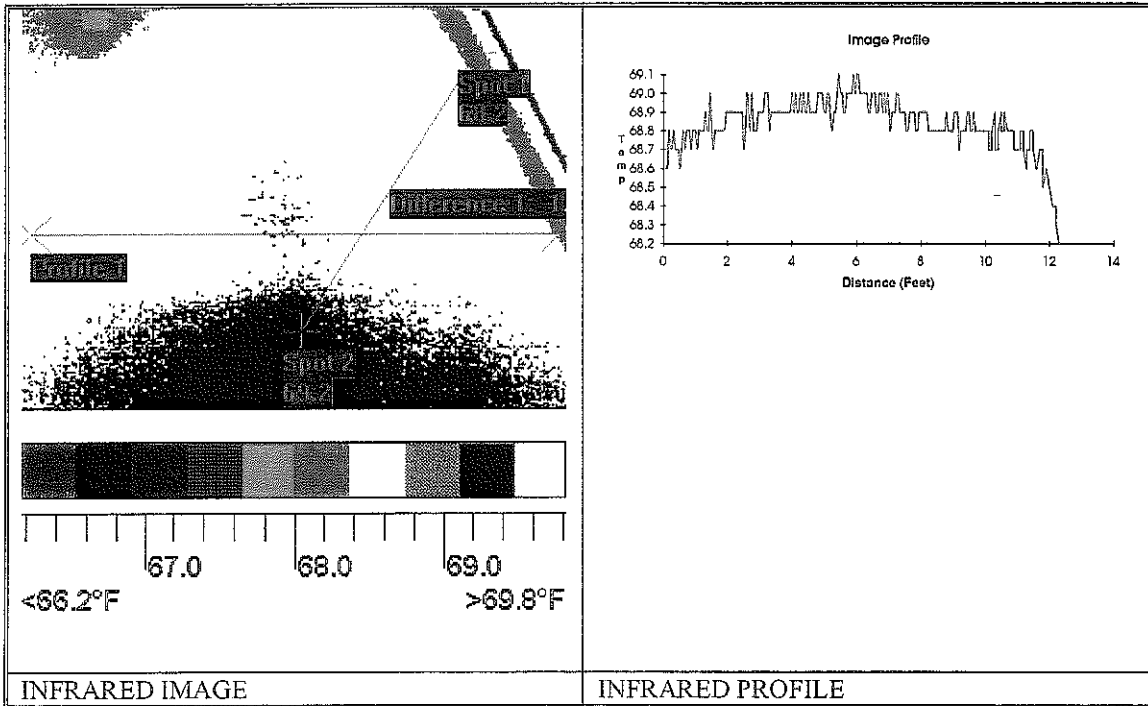

THERMAL IMAGE DATE

IMAGE NAME	a:\01.tif
MINIMUM TEMPERATURE	68.2
MAXIMUM TEMPERATURE	69.2
TEMPERATURE DIFFERENCE	-1
TEMPERATURE UNITS	F

FIGURE 23. THERMOGRAPHIC INSPECTION OF BLUEGRASS PARKWAY
(M.P. 34.4).

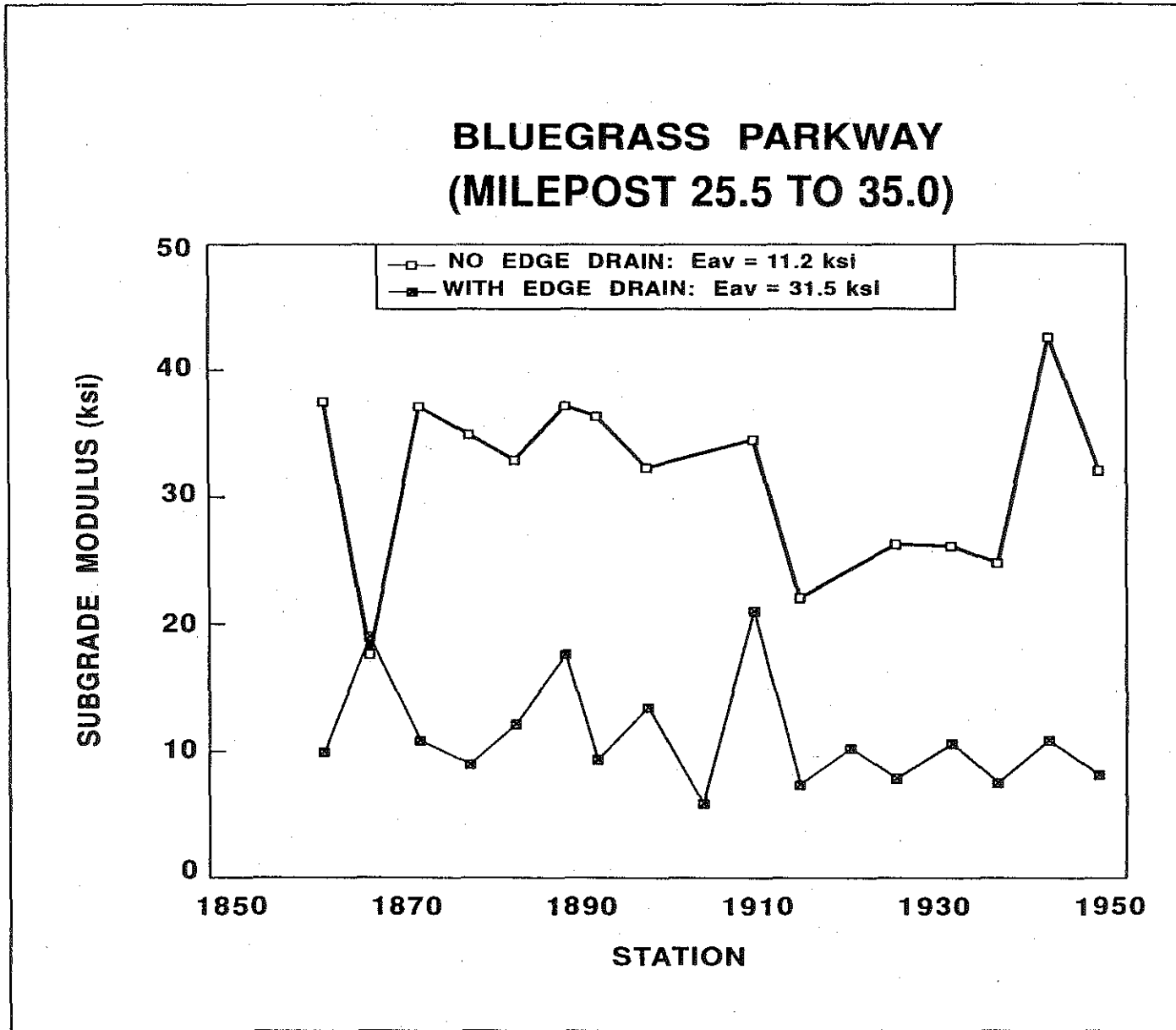

FIGURE 24. SUBGRADE MODULUS BEFORE AND AFTER EDGE DRAINS.

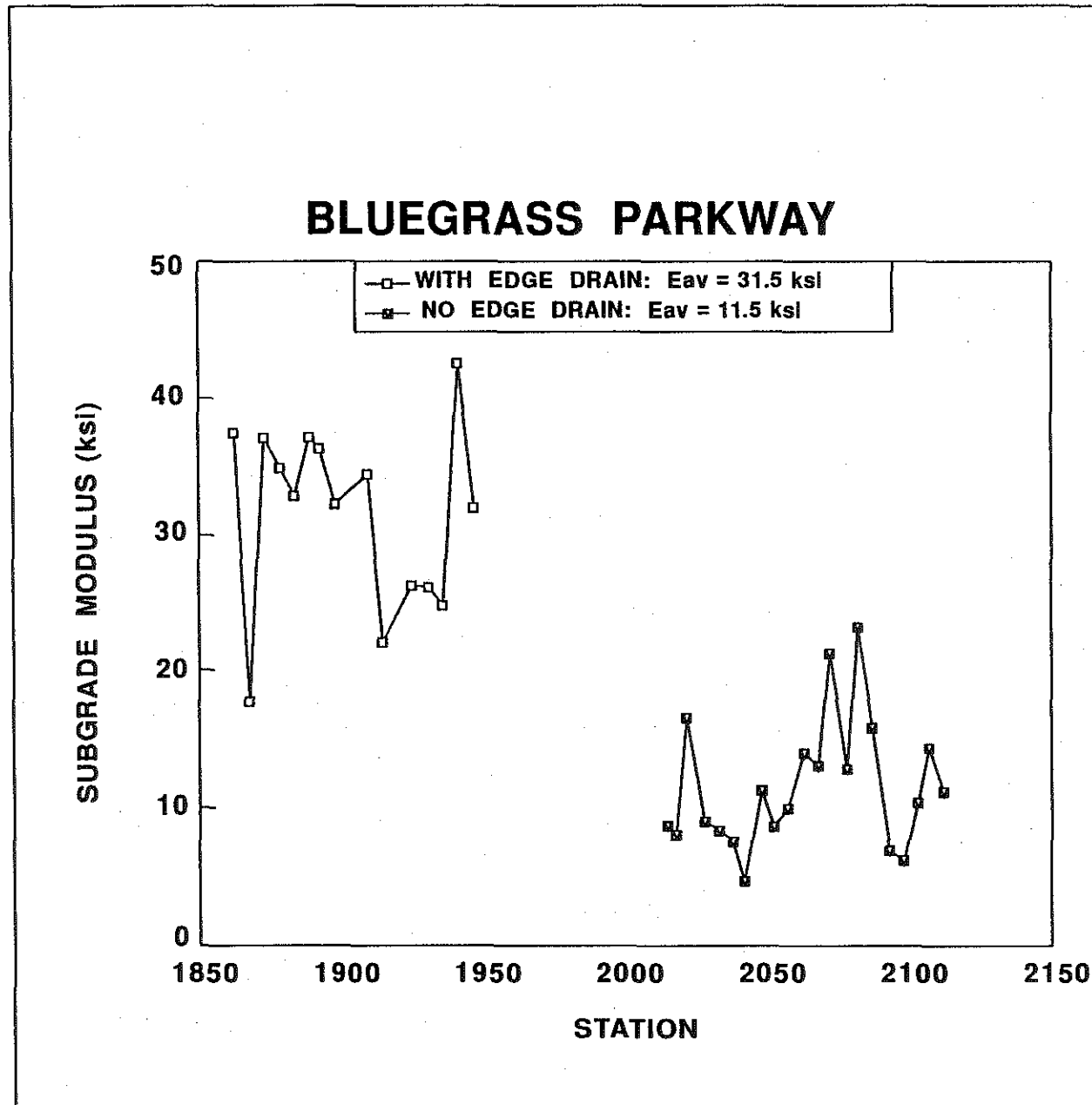

FIGURE 25. SUBGRADE MODULUS FOR PAVEMENT WITH EDGE DRAINS AND PAVEMENT WITHOUT EDGE DRAINS.

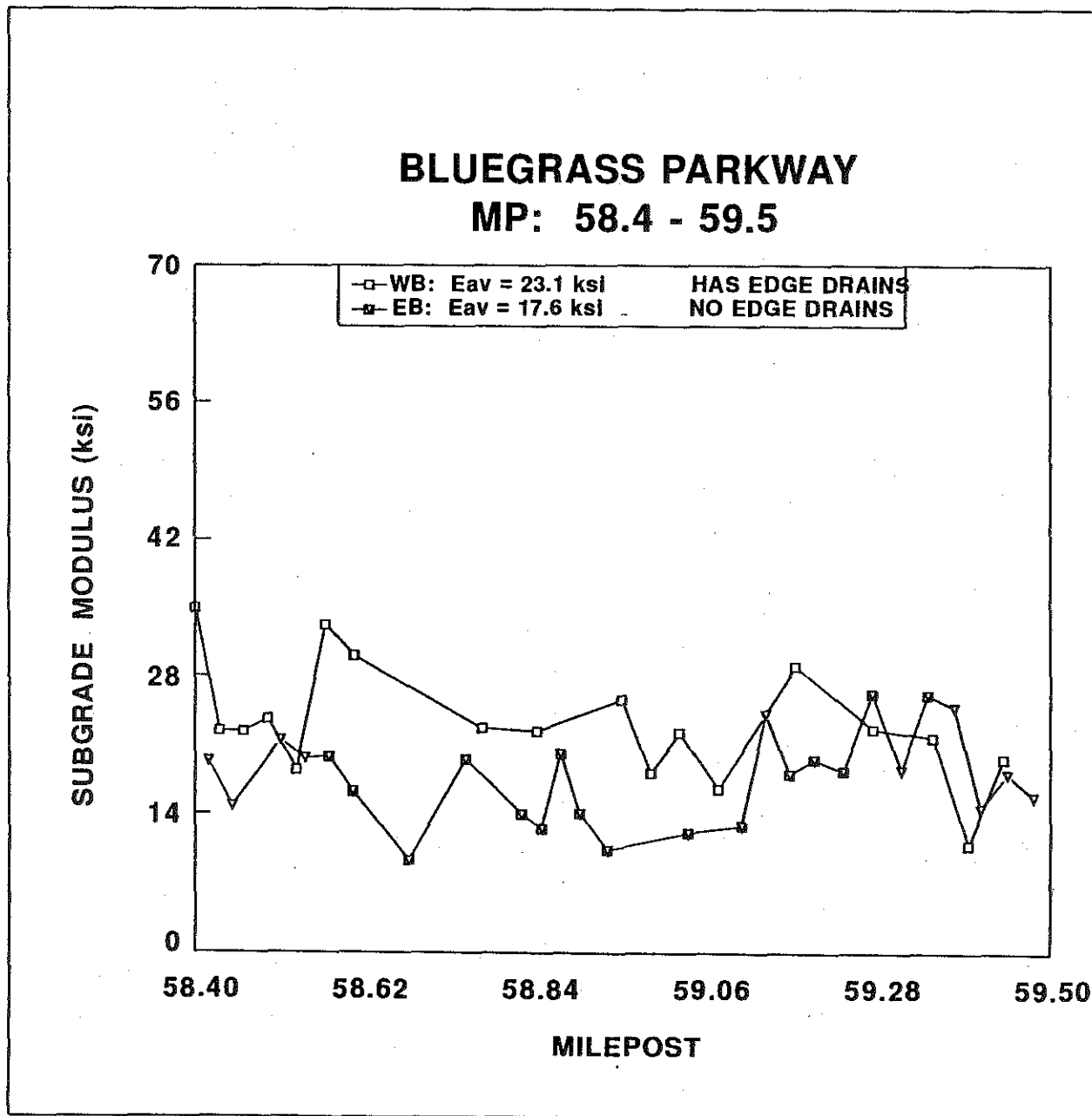

FIGURE 26. SUBGRADE MODULUS FOR PAVEMENT WITH EDGE DRAINS AND PAVEMENT WITHOUT EDGE DRAINS.

**BLUEGRASS PARKWAY
MP: 56.4 - 57.4**

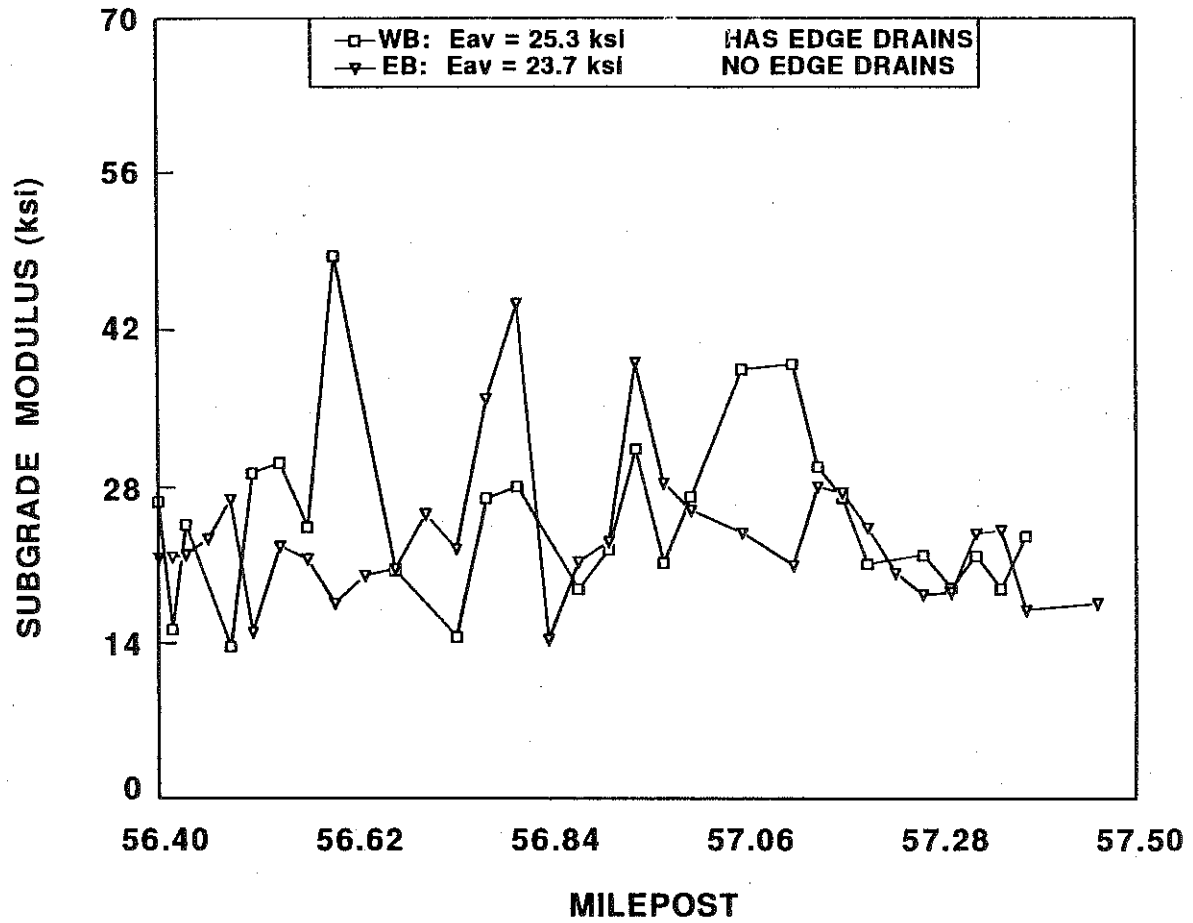

FIGURE 27. SUBGRADE MODULUS FOR PAVEMENT WITH EDGE DRAINS AND PAVEMENT WITHOUT EDGE DRAINS

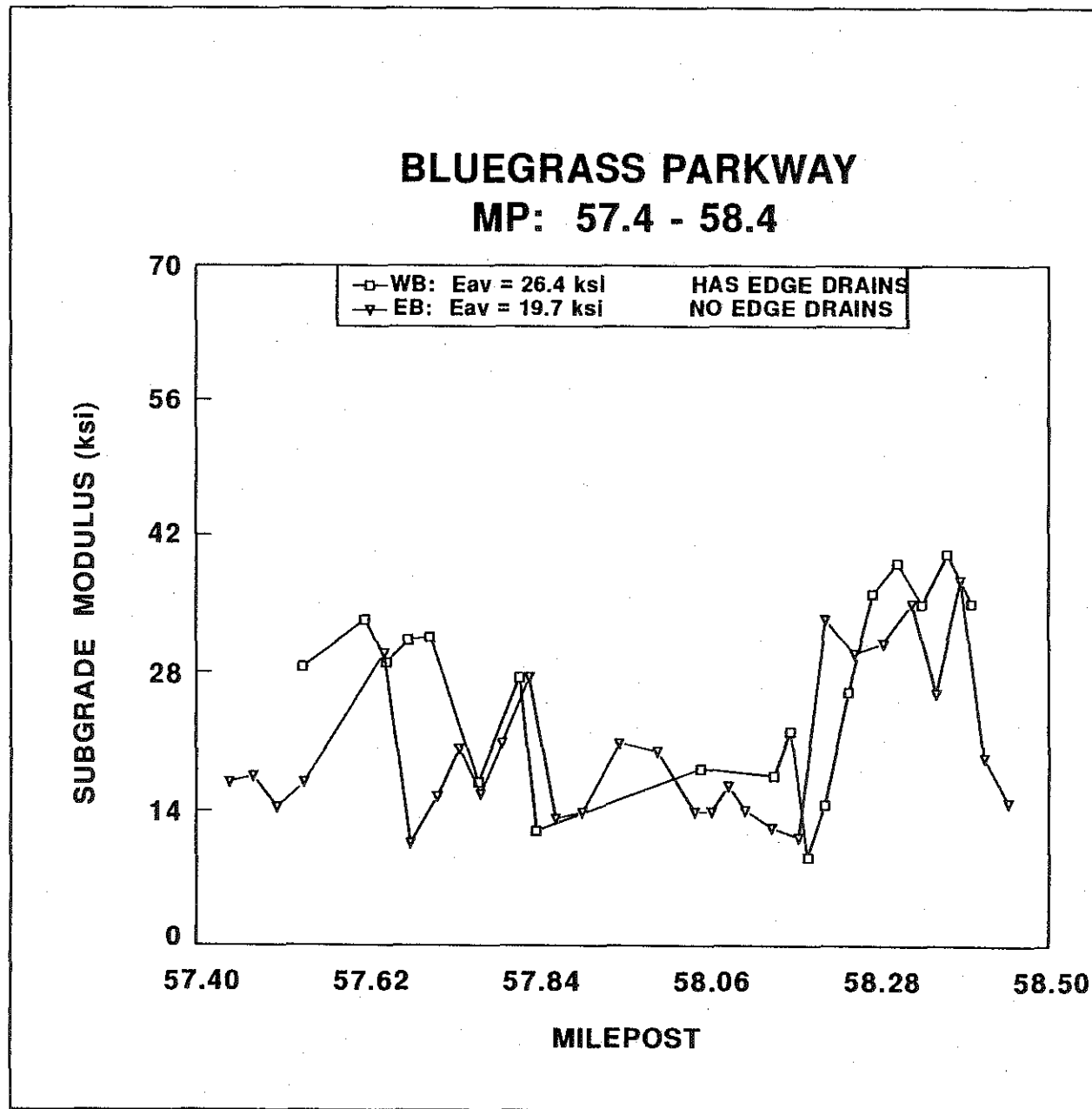

FIGURE 28. SUBGRADE MODULUS FOR PAVEMENT WITH EDGE DRAINS AND PAVEMENT WITHOUT EDGE DRAINS.

TABLE 9. FWD TEST RESULTS ON BLUEGRASS PARKWAY (MILEPOST 56.40 - 59.40)

AVERAGE SUBGRADE MODULUS (KSI)	MILEPOST (56.4-57.4)	MILEPOST (57.4-58.4)	MILEPOST (58.4-59.4)
WITH EDGE DRAIN	25.3	26.4	23.1
WITHOUT EDGE DRAIN	23.7	19.7	17.6
% DIFFERENCE	6.3	25.4	23.8

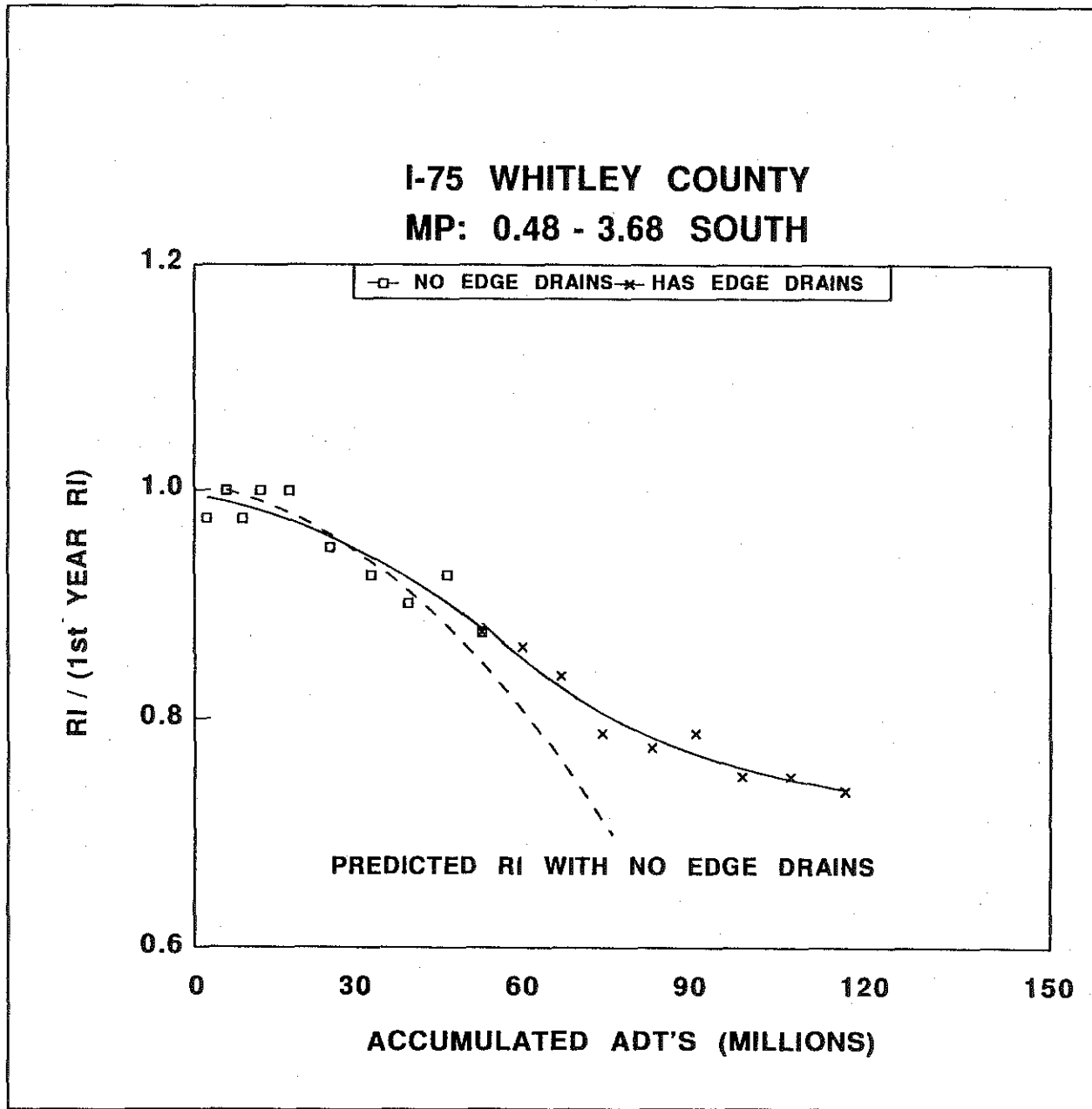

FIGURE 29. CHANGE IN RI AS A FUNCTION OF ADT.

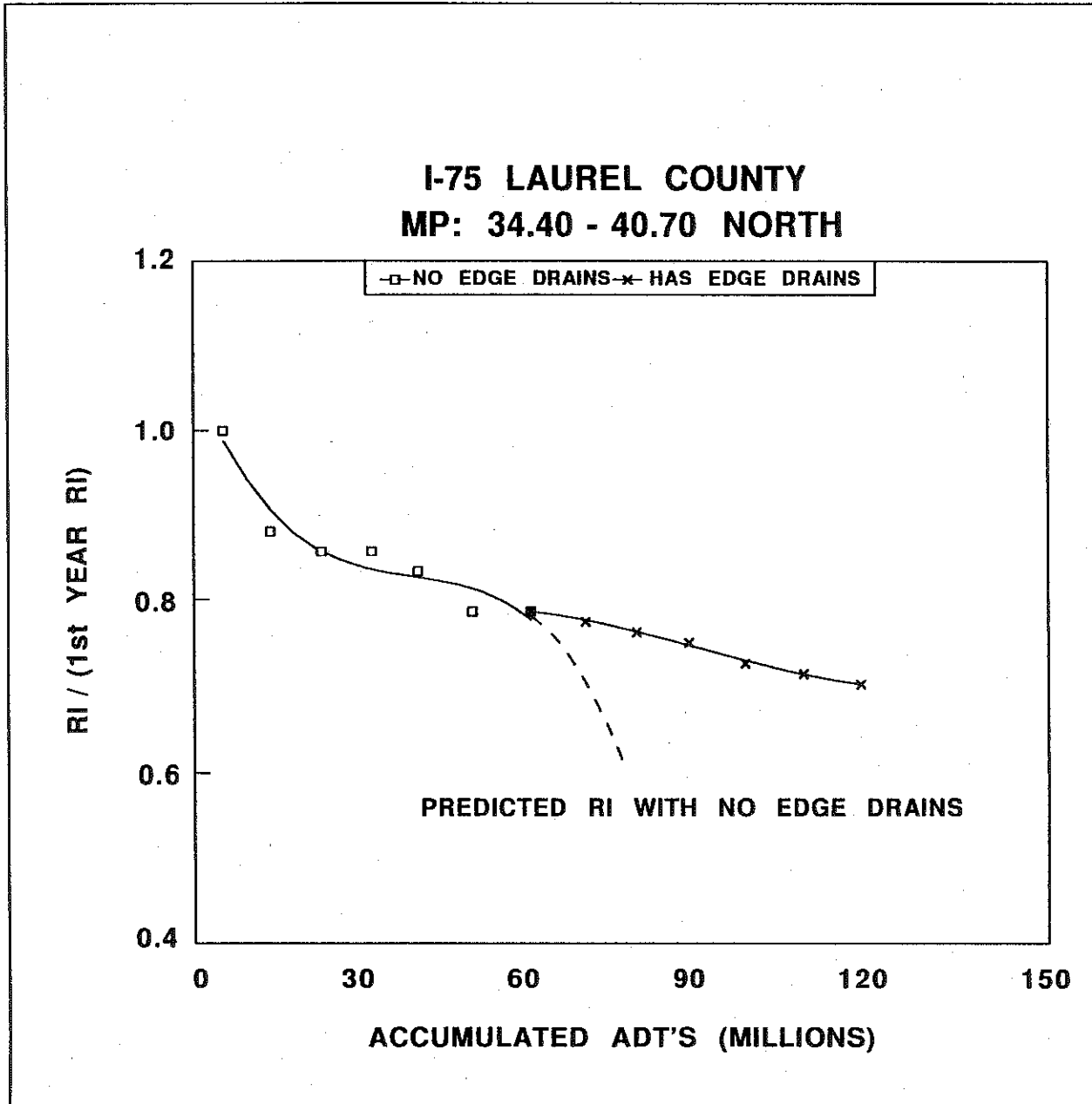

FIGURE 30. CHANGE IN RI AS A FUNCTION OF ADT.

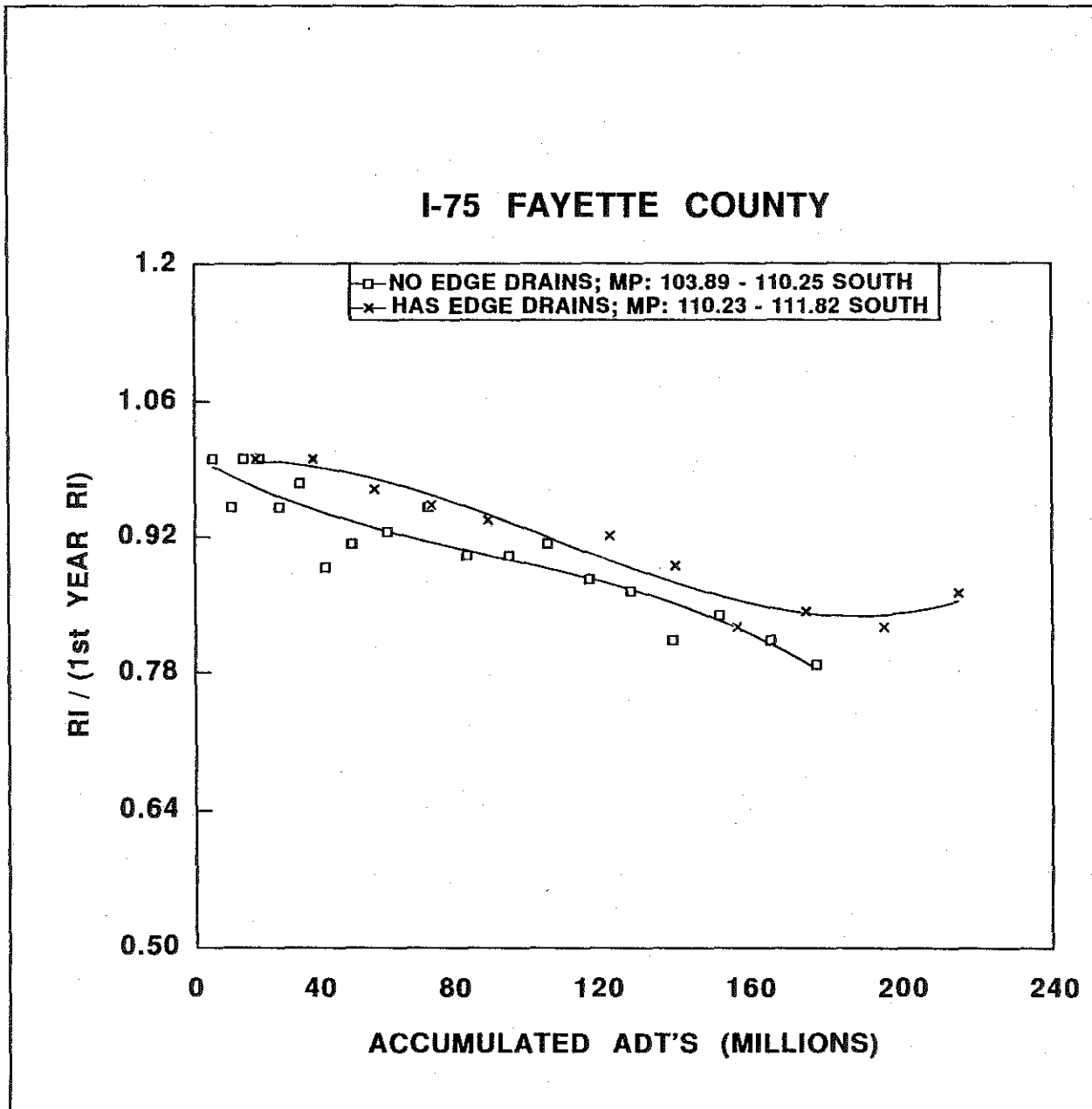

FIGURE 31. CHANGE IN RI AS A FUNCTION OF ADT.

I-64 JEFFERSON COUNTY

MP: 0.72 - 1.34 EAST

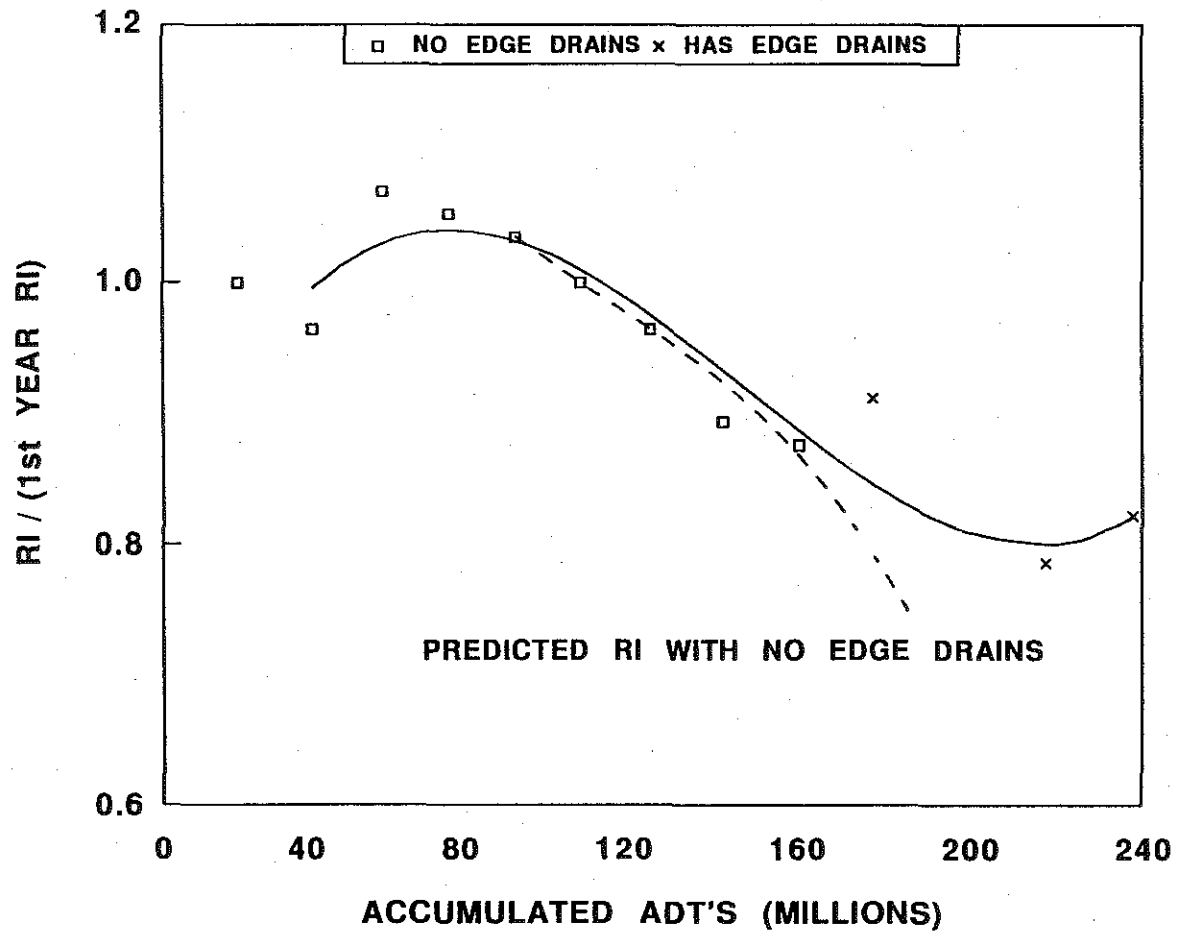

FIGURE 32. CHANGE IN RI AS A FUNCTION OF ADT.

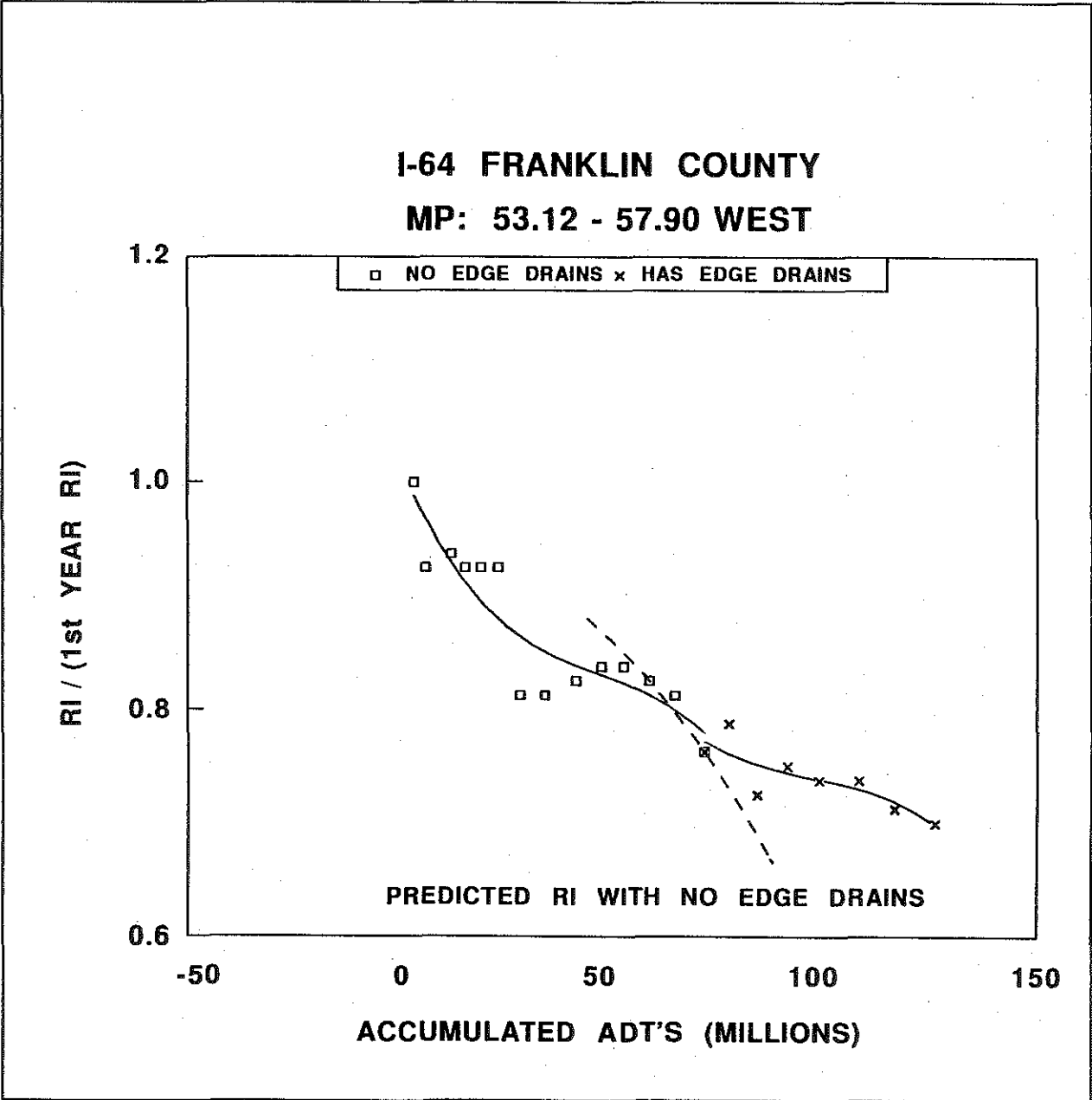

FIGURE 33. CHANGE IN RI AS A FUNCTION OF ADT.

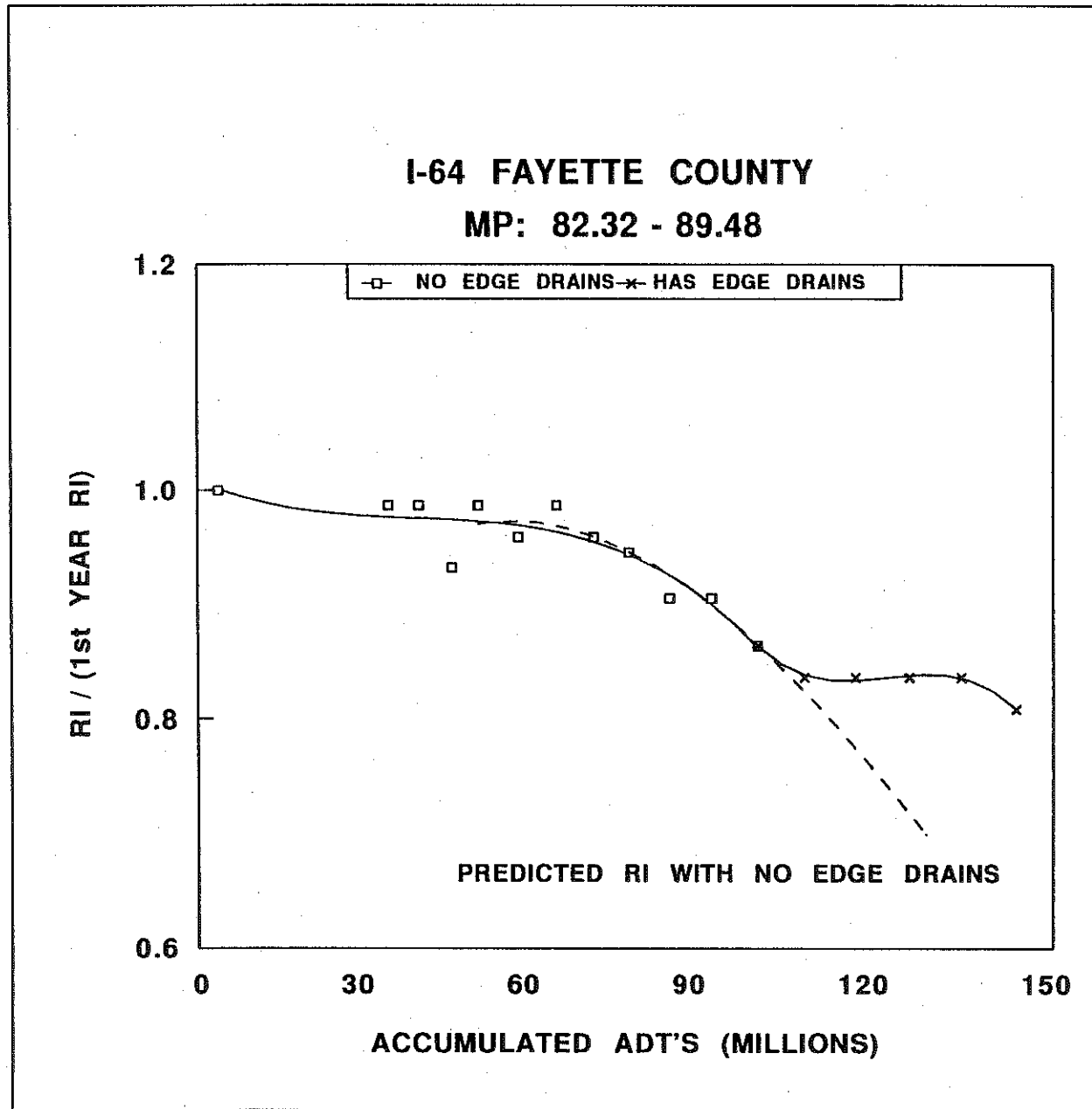

FIGURE 34. CHANGE IN RI AS A FUNCTION OF ADT.

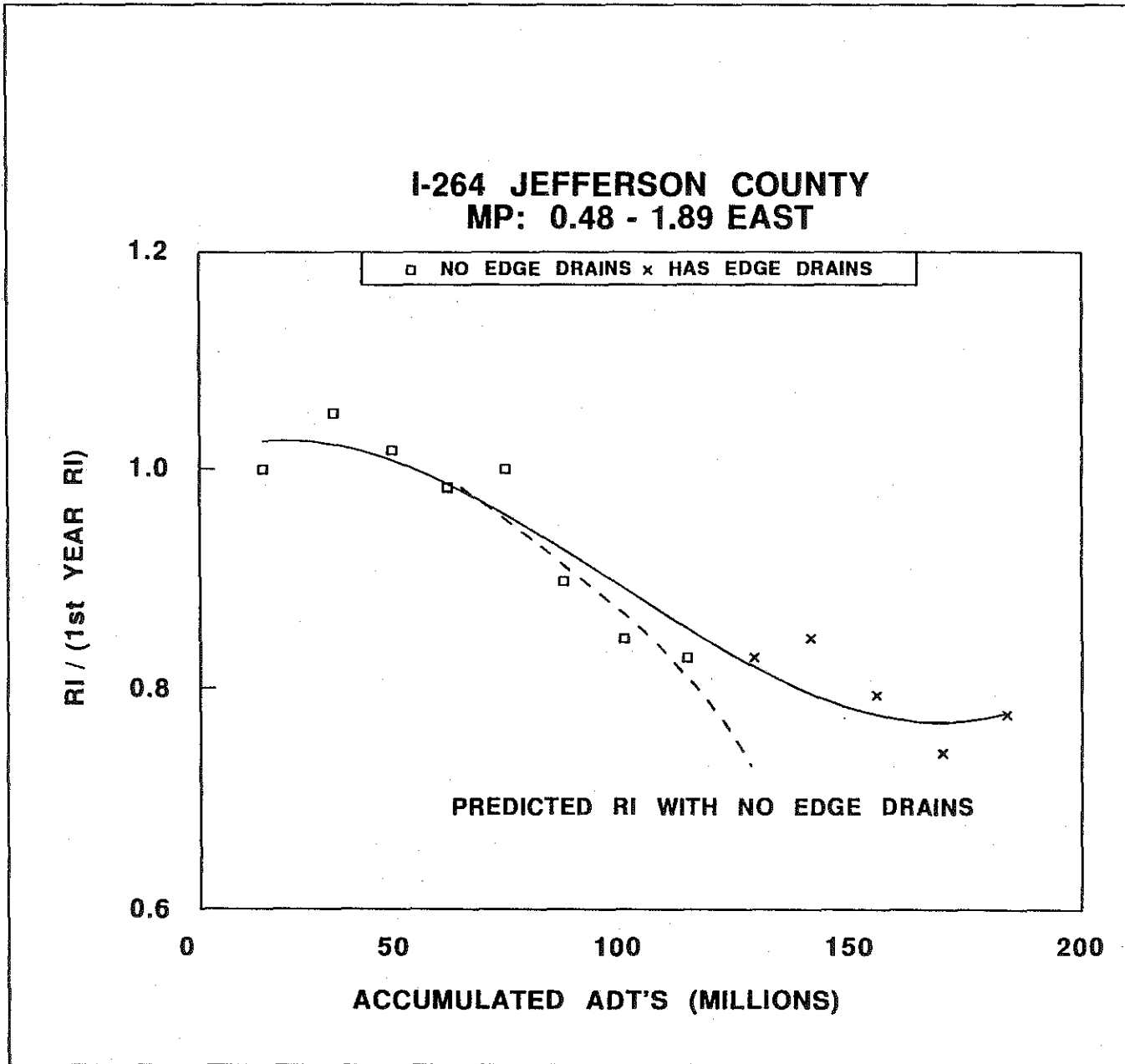

FIGURE 35. CHANGE IN RI AS A FUNCTION OF ADT.

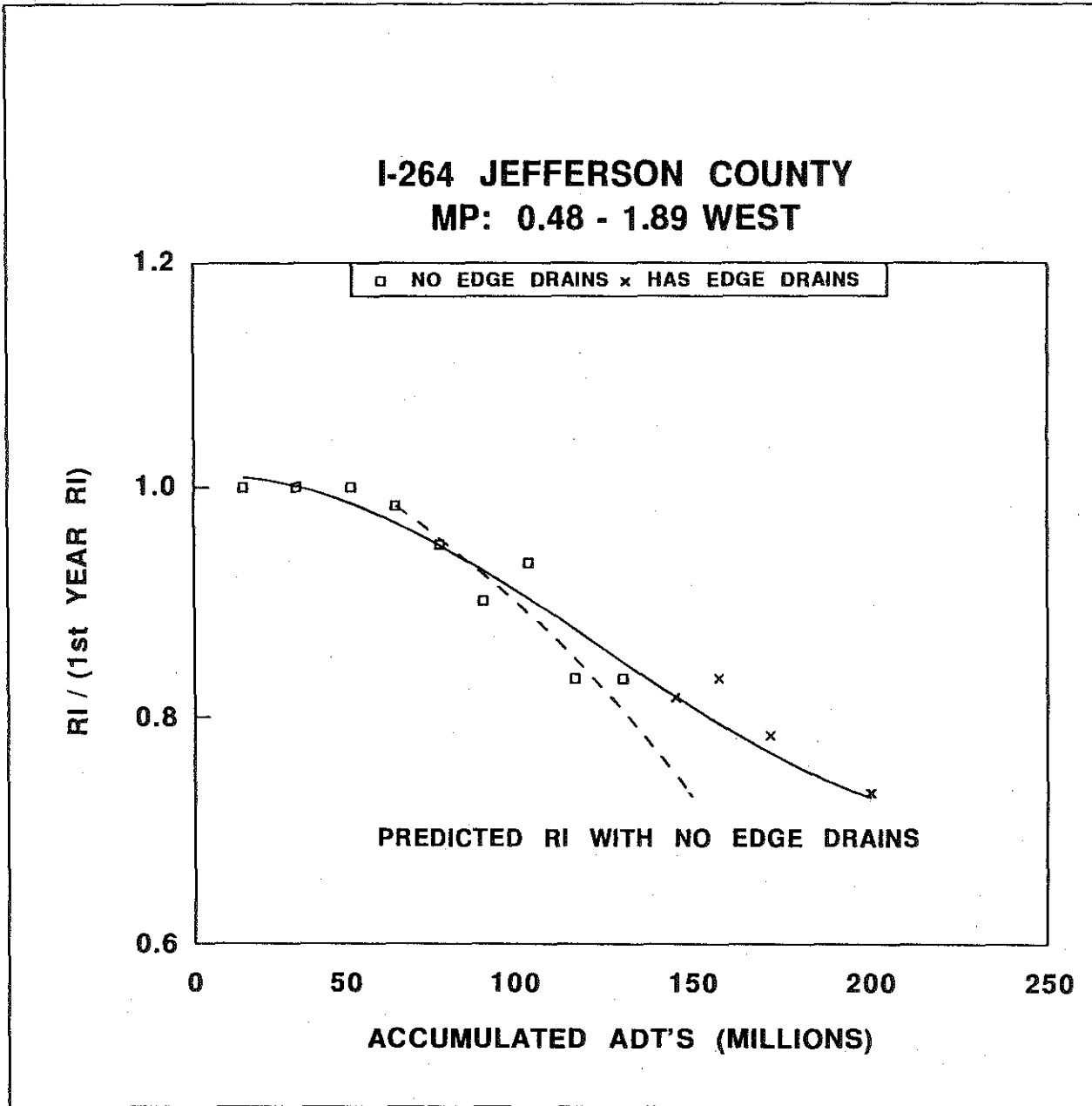

FIGURE 36. CHANGE IN RI AS A FUNCTION OF ADT.

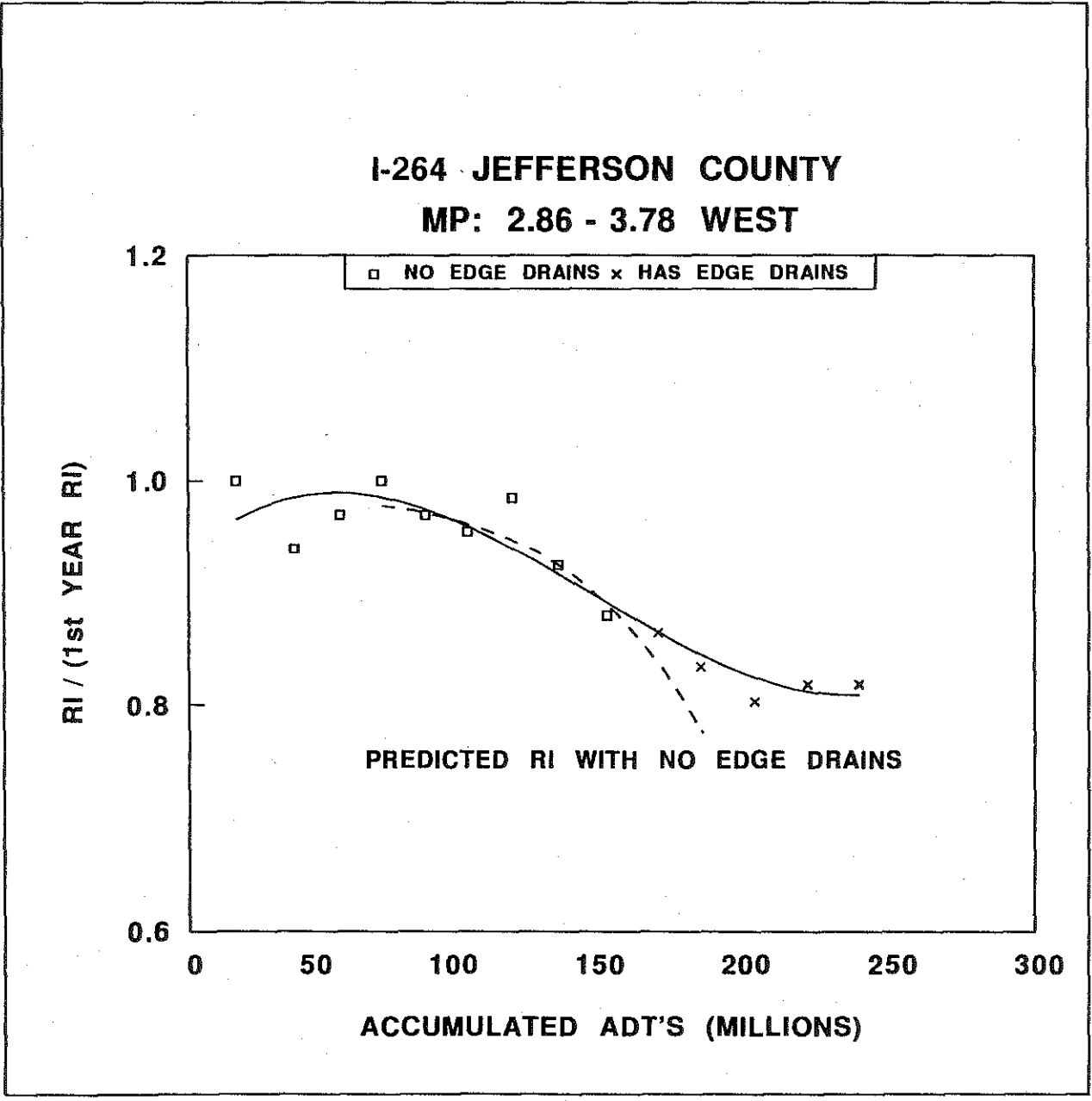

FIGURE 37. CHANGE IN RI AS A FUNCTION OF ADT.

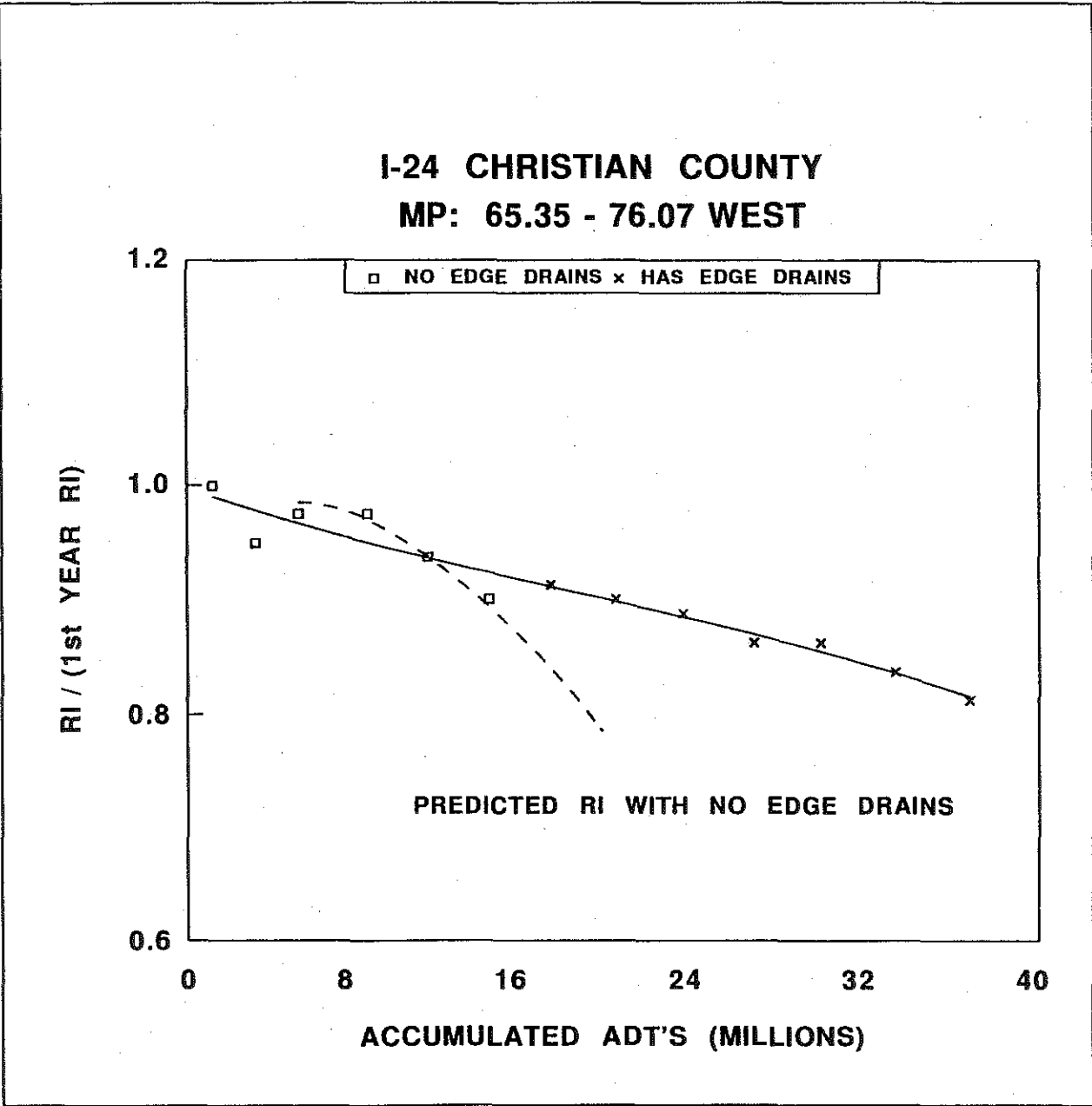

FIGURE 38. CHANGE IN RI AS A FUNCTION OF ADT.

I-24 CHRISTIAN COUNTY
MP: 76.07 - 85.56 WEST

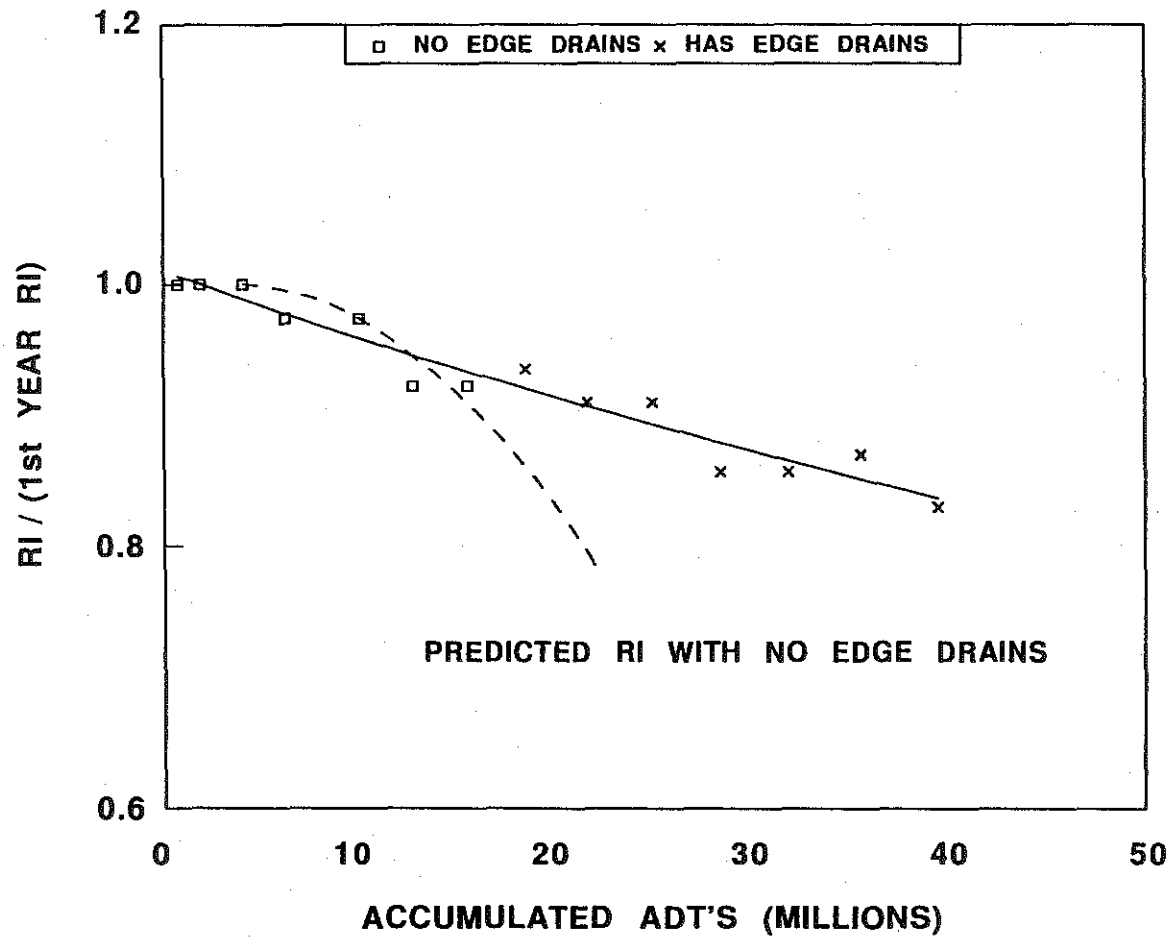

FIGURE 39. CHANGE IN RI AS A FUNCTION OF ADT.

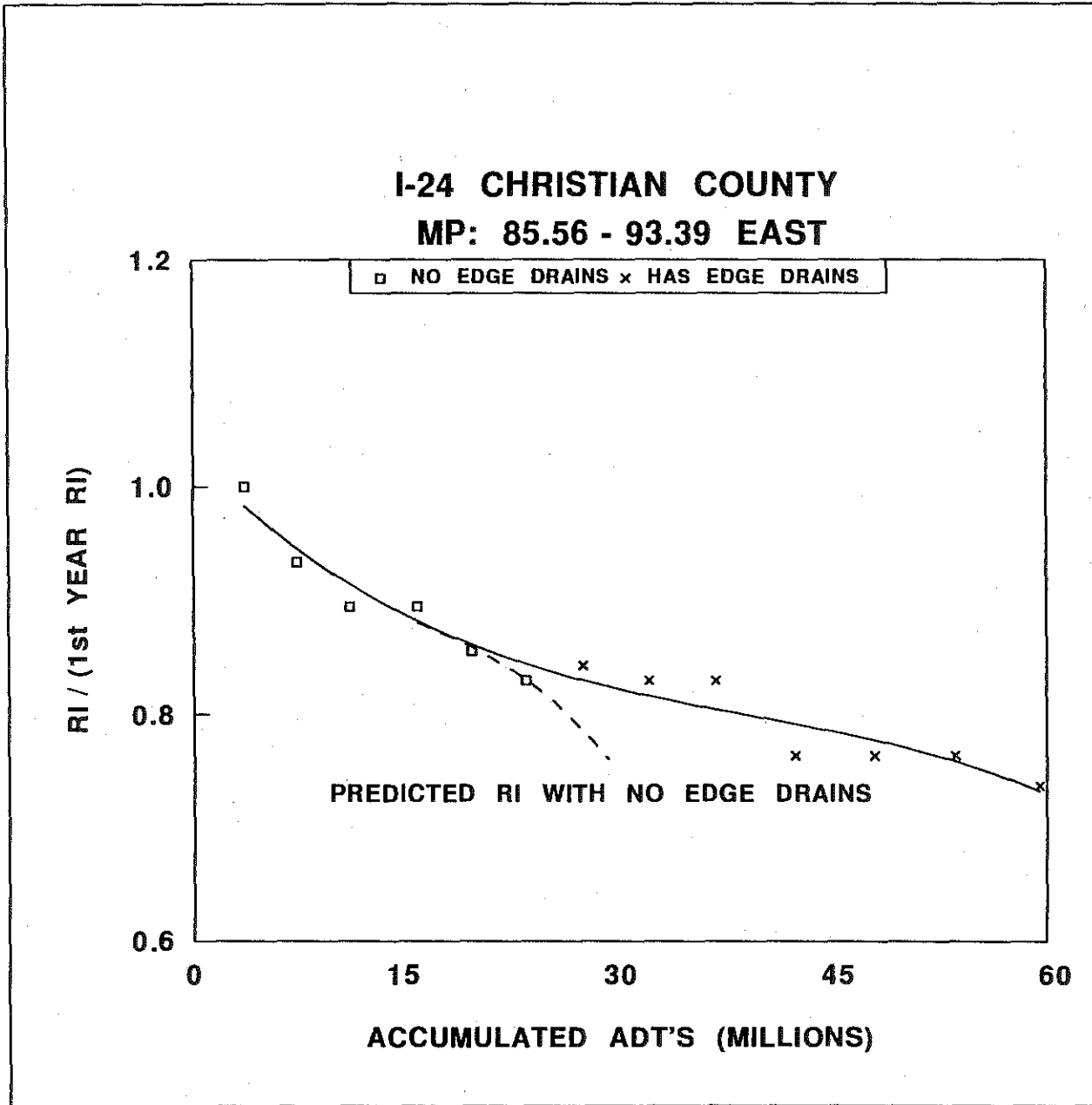

FIGURE 40. CHANGE IN RI AS A FUNCTION OF ADT.

TABLE 10. PREDICTED INCREASE IN PAVEMENT LIFE OF PAVEMENTS WITH EDGE DRAINS

SITE	RI(1)	RI(min)	RI(min)/RI(1)	PREDICTED ACCUMULATED TRAFFIC AT RI(min)		DIFFERENCE (MILLIONS)	1992 ADT	PRED. EXT. LIFE (YEARS)	RI WHEN EDGE DRAINS INSTALLED
				NO EDGE DRAINS	HAS EDGE DRAINS				
I-75 FAYETTE CO. MP: 103.89 - 111.82 S	4.0	2.7	0.675	180,000,000	300,000,000	120.0	40,000	8.2	4.00
I-75 LAUREL CO. MP: 34.40 - 40.70	4.2	2.7	0.643	72,500,000	150,000,000	77.5	32,130	6.6	3.25
I-24 WHITLEY CO. MP: 0.48 - 3.68	4.0	2.7	0.675	75,000,000	180,000,000	105.0	26,400	10.9	3.50
I-24 CHRISTIAN CO. MP: 65.35 - 76.00	4.0	2.7	0.675	22,500,000	65,850,000	43.4	9,620	12.3	3.65
I-24 CHRISTIAN CO. MP: 76.07 - 85.56	4.1	2.7	0.659	26,000,000	73,800,000	47.8	10,600	12.4	3.80
I-24 CHRISTIAN CO. MP: 85.56 - 93.39	3.8	2.7	0.711	31,500,000	62,500,000	31.0	16,250	5.2	3.20
I-64 FRANKLIN CO. 53.12 - 57.90	4.0	2.7	0.675	86,500,000	135,000,000	48.5	26,300	5.1	3.15
I-64 FAYETTE CO. MP: 82.32 - 89.48	3.7	2.7	0.730	124,000,000	158,200,000	34.2	26,260	3.6	3.05
I-264 JEFFERSON CO. MP: 2.86 - 3.78	3.3	2.7	0.818	170,000,000	200,000,000	30.0	49,950	1.6	2.85

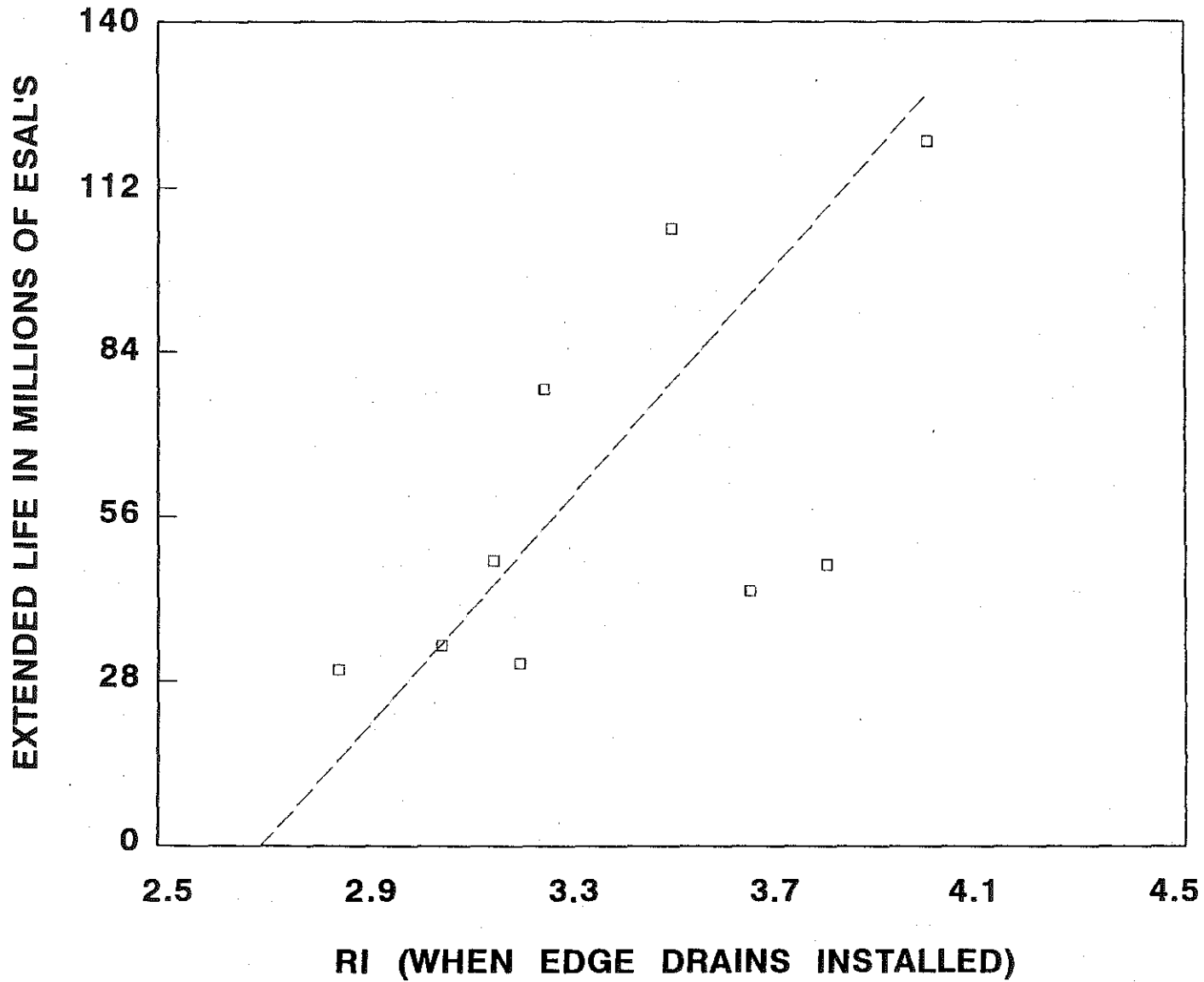

FIGURE 41. RELATIONSHIP BETWEEN EXTENDED PAVEMENT LIFE AND RIDE INDEX (WHEN EDGE DRAINS INSTALLED).

TABLE 11. PREDICTED COST SAVINGS USING EDGE DRAINS

SITE	RI(1)	RI(min)	PREDICTED YEARS AND ACCUMULATED ESAL'S AT RI = 2.7		YEAR OF OPENING AND YEAR DRAINS INSTALLED	DRAINS INSTALLED AT YEAR	EFFECTIVE COST IN TODAY'S DOLLARS		COST DIFF. (\$/MILE)
			NON DRAINED	DRAINED			NON DRAINED	DRAINAGE	
I-75 FAYETTE CO. MP: 103.89 - 111.82	4.0	2.7	YEAR: 28 ESAL'S: 26.65	> 30 48.98	1964 1981	17	2,742,373	2,739,658	2,715
I-75 LAUREL CO. MP: 34.40 - 40.70	4.2	2.7	YEAR: 16 ESAL'S: 8.50	22.6 22.0	1969 1985	16	2,809,971	2,789,108	20,863
I-24 WHITLEY CO. MP: 0.48 - 3.68	4.0	2.7	YEAR: 24 ESAL'S: 13.73	> 30 36.53	1963 1985	22	2,752,485	2,731,099	21,385
I-24 CHRISTIAN CO. MP: 65.35 - 93.39	4.0	2.7	YEAR: 13 ESAL'S: 4.87	23.00 16.61	1975 1986	11	2,892,880	2,801,952	90,928
I-64 FRANKLIN CO. 53.12 - 57.90	4.0	2.7	YEAR: 24 ESAL'S: 10.42	> 30 18.07	1962 1986	24	2,752,485	2,728,409	24,076
I-64 FAYETTE CO. MP: 82.32 - 89.48	3.7	2.7	YEAR: 27 ESAL'S: 14.04	> 30 18.99	1963 1988	25	2,744,651	2,727,194	17,457
I-64 JEFFERSON CO. MP: 2.86 - 3.78	3.3	2.7	YEAR: 18 ESAL'S: 7.73	19.6 9.10	1963 1988	25	4,092,750	4,096,435	-3,685

83

APPENDIX A
EDGE DRAIN SPECIFICATION

**PROPOSED SPECIFICATION
FOR PAVEMENT EDGE DRAIN
INSTALLATION IN KENTUCKY**

by

L. John Fleckenstein
Engineering Geologist

and

David L. Allen
Chief Research Engineer

Kentucky Transportation Center
College of Engineering
University of Kentucky
Lexington, Kentucky

August 1994

**SPECIAL PROVISION FOR PREFABRICATED
PERFORATED ROUND PIPE EDGE DRAIN**

SPECIAL PROVISION FOR PREFABRICATED PERFORATED ROUND PIPE EDGE DRAIN

I. DESCRIPTION

This Special Provision shall apply when indicated on the plans or in the proposal. Section references herein are to the Department's current Standard Specifications for Road and Bridge Construction. This work shall consist of furnishing and installing a prefabricated perforated round pipe drain in accordance with this Special Provision and as directed by the Engineer.

II. MATERIALS

A. General. The core of the prefabricated round pipe edge drain shall comply with AASHTO M 252. The pipe shall have a minimum I.D. of 100 mm. A geotextile shall be used to reduce infiltration of fines into the pipe drain, either a fabric wrapped trench or a sock wrapped pipe (Drawing No. 1).

B. Acceptance. The perforated pipe shall comply with AASHTO M 252.

III. CONSTRUCTION REQUIREMENTS

A. Inspection, Handling, and Storage. The prefabricated perforated pipe drain, and fittings shall be inspected upon receipt at the job site. The shipment shall be inspected for conformance to product specifications, contract documents, and checked for damage. Damaged or deformed material shall be removed from the project. The material shall be stored to prevent damage. The material shall be stored away from exposure to ultraviolet light and direct sunlight.

B. Installation of Pipe Drain. The prefabricated perforated pipe drain shall be installed in a 300 mm wide trench (Drawing No. 2). A clean neat edge shall be cut in the existing bituminous pavement before excavating the trench. The pipe shall be installed 51 mm above the bottom of the trench. The trench shall be cut to a depth 102 mm below the base of the existing DGA. The trench shall be backfilled with a open graded aggregate (specified by the engineer), and compacted in three lifts.

Splices, when required, shall be made prior to placing the pipe drain in the trench. Splices shall be made using splice kits furnished by the manufacturer and in accordance with the manufacturer's written instructions. Any equipment required for the splicing shall be furnished by the Contractor. Assembly of joints shall not damage the pipe and shall not impede the open flow area of the pipe, and retain the position of the pipe drain as designated on the plans or as directed by the Engineer. The joints shall prevent infiltration of the backfill or any fine material.

Means shall be provided to hold the prefabricated perforated pipe drain 50 mm above the bottom of the trench during backfilling. The backfill shall be placed in three lifts and shall be densified.

The final elevation of the sand backfill shall be no less than 100 mm below the surface of the top of the trench. When this requirement is not met, the Contractor shall add additional backfill. The remainder of the trench shall be backfilled with a Class I bituminous concrete surface.

C. Installation of Edge Drain Outlets. Outlets shall be constructed at the locations shown on the plans or as directed by the Engineer. Outlet fittings to transition from the prefabricated edge panel drain to a non-perforated 100-mm smooth lined pipe shall be furnished by the manufacturer, and shall be installed in accordance with the manufacturer's written instructions. The connection of the pipe drain to an outlet pipe shall be made with a 45-degree elbow and bending the pipe drain shall not be permitted. At the sags of vertical curves, the pipe drain may be connected to the outlet pipe with a tee connector. The connection from the pipe drain to the outlet pipe shall be securely connected without impeding the flow.

The outlet pipe leading to the headwall from the pipe drain shall be one of the following alternates:

- 1) Corrugated Polyethylene Pipe Type S, meeting the requirements of AASHTO M 252.
- 2) PVC pipe meeting the requirements of either ASTM D 1785 for schedule 40 or ASTM D 2241 for SDR 17.
- 3) Corrugated steel or corrugated aluminum pipe meeting the requirements specified in Section 705.
- 4) Ribbed PVC pipe meeting the requirements of ASTM F 794 Series 46.
- 5) Corrugated PVC pipe meeting the requirements of ASTM F 949.

The outlet pipe which is chosen by the contractor from the five alternates shall also be precast into the headwall to allow for a smooth transition from the outlet to the headwall. Headwalls not utilizing one of the five alternates are not acceptable and will be removed from the site at the contractors expense.

All outlet pipe shall be 100-mm diameter, unless otherwise noted on the plans or in the proposal. Care shall be exercised to prevent sags, tears, or compression in the outlet pipes. Trenches excavated for outlet pipes shall be backfilled with dense-graded aggregate.

The outlet pipe shall be installed at a desired 4 percent grade, or 3 percent

minimum to insure positive outflow.

All material removed from the trench which is not used for other purposes required by the contract or as specified or permitted by the Engineer, shall be removed from the project site at no additional cost to the Department.

For those situations where guardrail will be attached to a structure, such as a bridge end or a pier, the placement of the outlet pipe shall be adjusted such that the guardrail posts will not be driven within a horizontal distance of no less than 300 mm of the outlet pipe for prefabricated perforated pipe drains.

Where guardrail is not attached to a structure, the placement of the guardrail posts and/ or the outlet pipe shall be adjusted such that the guardrail posts are not driven within a horizontal distance of no less than 300 mm of the outlet pipe for prefabricated perforated pipe drains.

The Contractor shall mark the location of the outlet pipe for prefabricated perforated pipe drains with paint or by other means as approved by the Engineer.

Damage to any outlet pipe by guardrail installation shall be acceptably repaired or the damaged outlet pipe removed and replaced by the Contractor, at no additional cost to the Department.

The outlet pipe headwall shall conform to Standard Drawing No. RDP-010-04. The pipe used in the headwall shall conform to the outlet pipe. The site for the headwall shall be undercut by 200 mm and backfilled with DGA. The DGA shall be mechanically compacted to achieve maximum density. The prepared surface for the headwall shall be constructed so that after placement of the headwall that the headwall slopes 12 mm (0.5 inches) per 300 mm (linear foot) for positive outlet flow from the headwall. When settlement occurs in the headwall prior to final inspection the contractor shall reset the headwall at his expense. The headwall shall also have a minimum of 150 mm of free board from the base of the headwall trough to the bottom of the ditch.

In addition to the requirements of Standard Drawing No. RDP-010-04, Crushed Aggregate Size No. 2 conforming to Section 805 of the Kentucky Standard Specifications for Road and Bridge Construction shall be used at all pavement subsurface drainage pipe headwall outlets. The Crushed Aggregate Size No. 2 shall be placed a minimum depth of 100 mm. The stone shall be placed a lateral distance of 0.6 m from the sides and the top of the headwall and for a distance of 1.2 m from the toe of the headwall.

Dense Graded Aggregate (DGA) removed to allow placement of the Crushed Aggregate Size No. 2 shall be used to dress existing shoulders where DGA is exposed. Other material removed to allow placement of the Crushed Aggregate Size No. 2 shall be disposed of as directed by the Engineer. No direct payment will be allowed for disposal of removed material.

D. Inspection of Prefabricated Perforated Pipe Drain Mainline and Outlet. The final product will be inspected using a mini camera. The mainline and the outlet pipe shall not be deflected greater than 5 percent, and shall be free of tears, debris, and sags.

The geotextile fabric surrounding the drain shall be free of rips or punctures. If the mainline or the outlet pipe is not properly installed, the mainline or the outlet shall be removed and replaced at the Contractor's expense.

E. Adjustment of Quantities. The Engineer reserves the right to make increases or decreases in the quantity of prefabricated perforated pipe drain constructed as may be required, in accordance with Section 104.02.

IV. METHOD OF MEASUREMENT AND BASIS OF PAYMENT

The prefabricated perforated pipe drain will be measured in linear meters complete and accepted in the final work. Payment for the accepted quantity at the contract unit price for perforated pipe drain will be full compensation for perforated pipe drain trench excavation; backfill, including dried natural sand and water; furnishing and installing all drain materials, including splices and fittings; and all equipment, labor, and incidentals necessary to complete the work.

Outlet pipe, outlet pipe headwall, bituminous mixtures, and other items required by the contract will be measured and paid for as specified elsewhere in the contract.

The contract unit price for Crushed Aggregate Size No. 2 will be full compensation for all materials, labor, and other incidentals necessary to place Crushed Aggregate Size No. 2 for control of vegetation and erosion at pipe drain outlet headwalls.

TYPICAL DETAIL FOR INSTALLATION OF PREFABRICATED PERFORATED PIPE DRAINS

PERFORATED PIPE AND FABRIC WRAPPED TRENCH

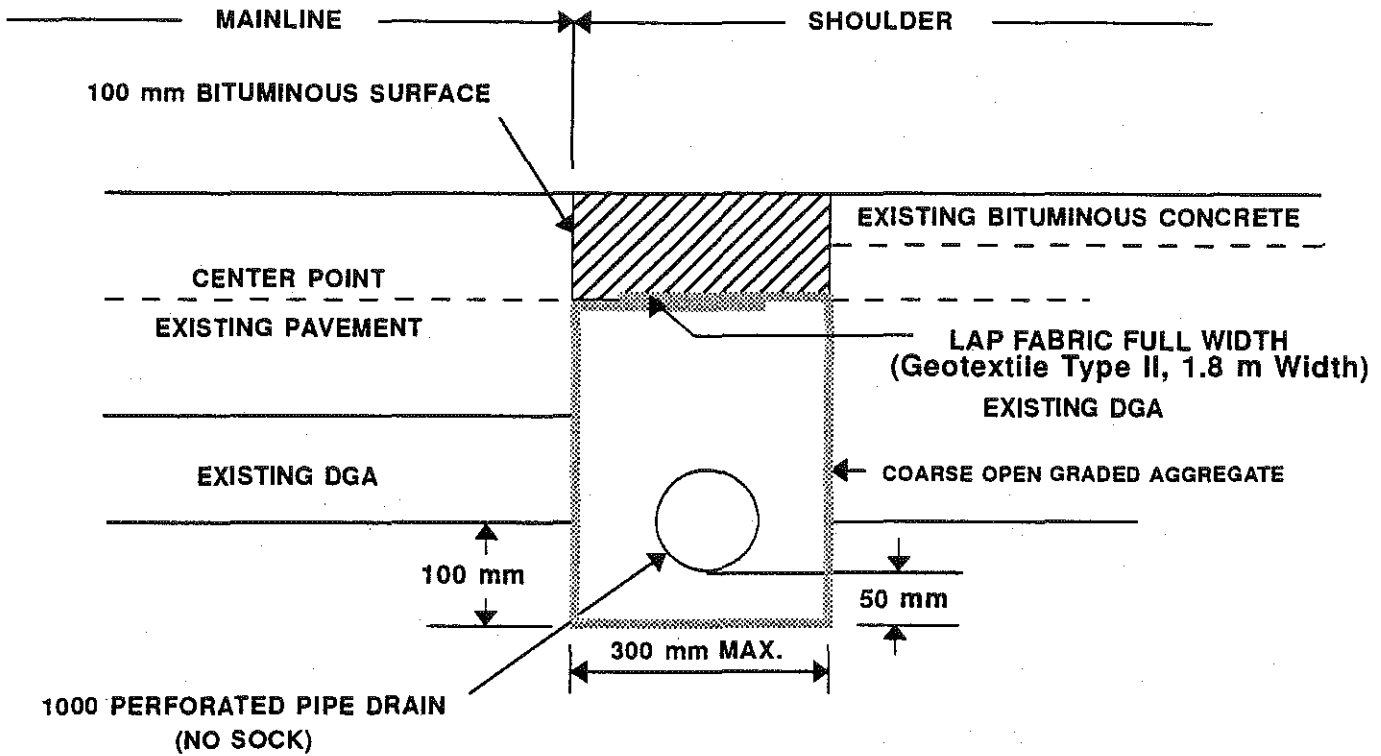

PERFORATED PIPE (SOCK WRAPPED)

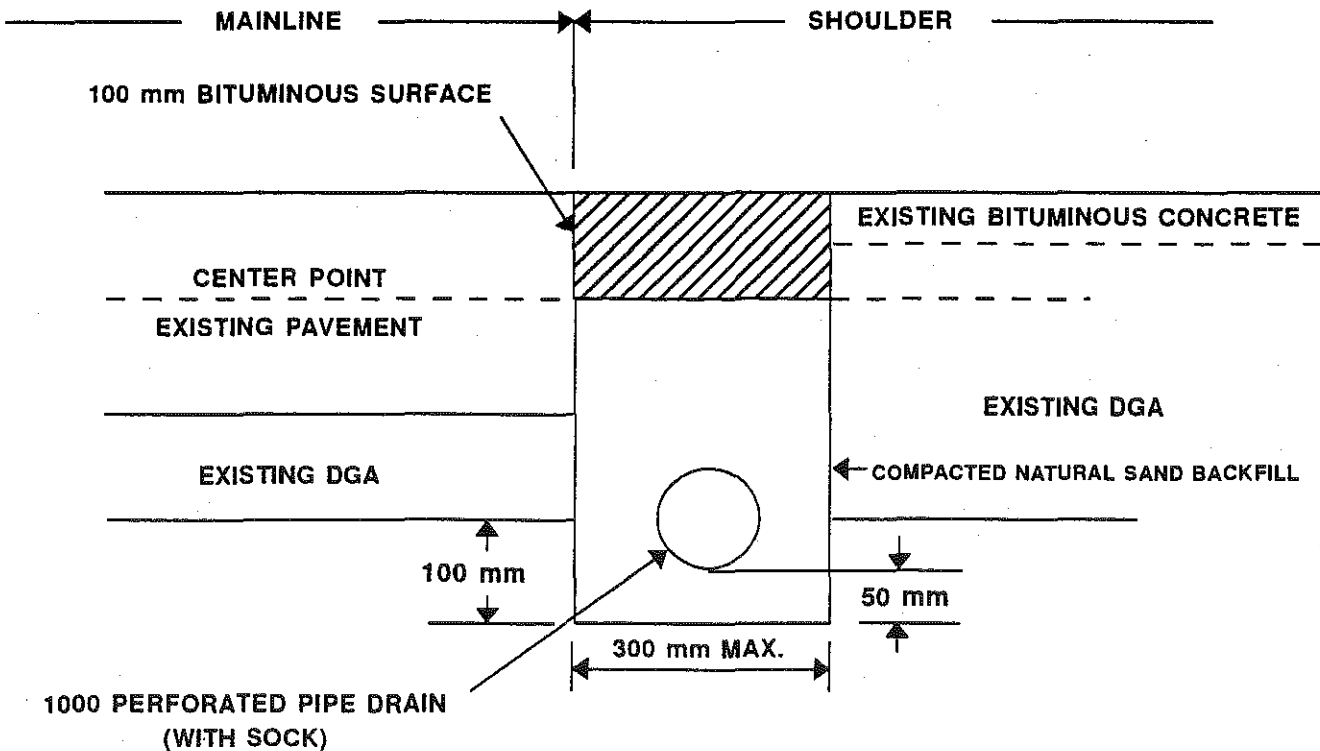

LONGITUDINAL PAVEMENT EDGE DRAIN (PERFORATED PIPE)

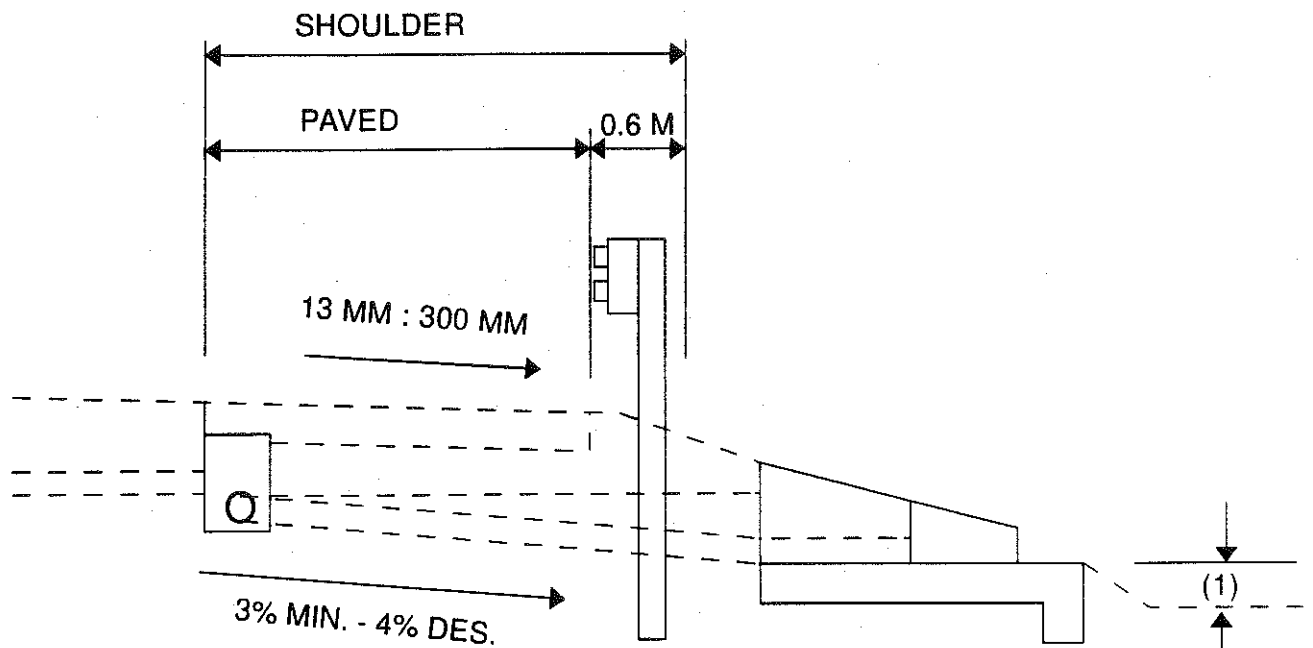

(1) 150 MM MINIMUM FREEBOARD TO THE BOTTOM OF THE DITCH

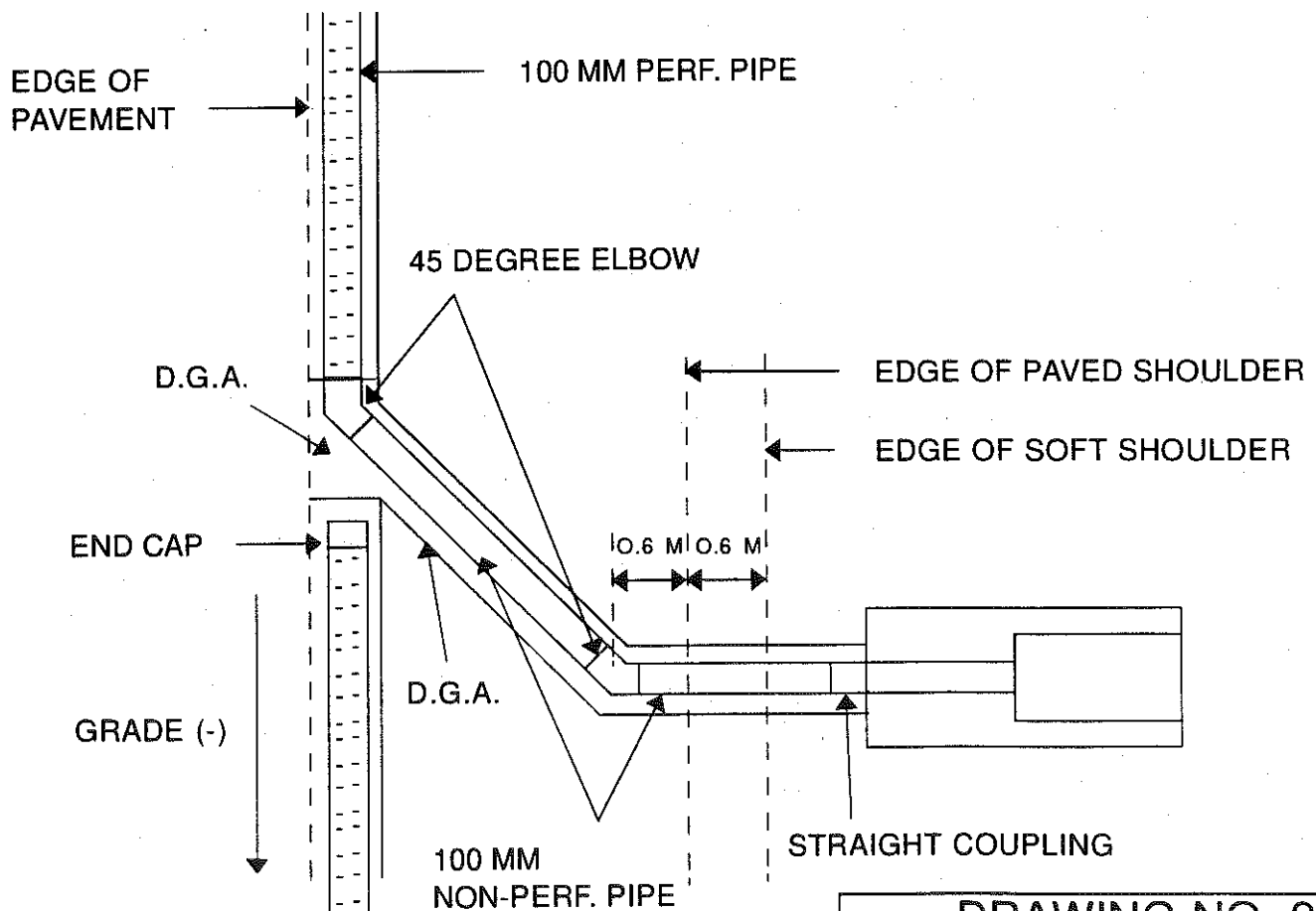

DRAWING NO. 2

**SPECIAL PROVISION FOR
PREFABRICATED PAVEMENT EDGE PANEL DRAIN**

SPECIAL PROVISION FOR PREFABRICATED PAVEMENT EDGE PANEL DRAIN

I. DESCRIPTION

This Special Provision shall apply when indicated on the plans or in the proposal. Section references herein are to the Department's current Standard Specifications for Road and Bridge Construction. This work shall consist of furnishing and installing a prefabricated edge panel drain in accordance with this Special Provision and as directed by the Engineer.

II. MATERIALS

A. General. The core of the prefabricated edge panel drain shall be rigid or semi-rigid high density polyethylene (HDPE) or polyvinylchloride (PVC). It shall be surrounded by a geotextile fabric conforming to Table II of Section 845.02. The core of the panel shall be chemically resistant to petroleum based chemicals, as well as naturally occurring soils. The panel drain shall have an inside cross-sectional thickness from 13 to 25 mm and a depth of from 300 to 450 mm.

B. Acceptance. The open area on the side of the core used for drainage shall be no less than 5 percent of the total core area in accordance with Drawing No. 1. The compressive strength of the core shall be no less than 138 kPa at 10 percent strain as determined by Standard Test Method ASTM D 1621. The cross-sectional area of the core shall not decrease more than 10 percent under a 103 kPa vertical load and the core shall not deflect more than 5 percent along the vertical axis (as installed) as determined by KM 64-XXX-92. In addition, the cross-sectional area available for water flow shall not be less than 3870 square mm under a 103 kPa vertical load when tested in accordance with KM 64-XXX-92.

III. CONSTRUCTION REQUIREMENTS

A. Inspection, Handling, and Storage. The prefabricated edge panel drain, and fittings shall be inspected upon receipt at the job site. The shipment shall be inspected for conformance to product specifications, contract documents, and checked for damage. Damaged or deformed material shall be removed from the job site. The material shall be stored to prevent damage. The material shall be stored away from exposure to ultraviolet light and direct sunlight.

B. Installation of Edge Drain. The prefabricated edge panel drain shall be installed in a trench as shown on Drawing No. 2 and 3. The prefabricated edge panel drain shall be installed on the shoulder side of the trench. A clean neat edge shall be cut in the existing bituminous pavement before excavating the trench. The top of the panel shall not be installed in a position higher than the center point of the

**SPECIAL PROVISION FOR
PREFABRICATED PAVEMENT EDGE PANEL DRAIN**

SPECIAL PROVISION FOR PREFABRICATED PAVEMENT EDGE PANEL DRAIN

I. DESCRIPTION

This Special Provision shall apply when indicated on the plans or in the proposal. Section references herein are to the Department's current Standard Specifications for Road and Bridge Construction. This work shall consist of furnishing and installing a prefabricated edge panel drain in accordance with this Special Provision and as directed by the Engineer.

II. MATERIALS

A. General. The core of the prefabricated edge panel drain shall be rigid or semi-rigid high density polyethylene (HDPE) or polyvinylchloride (PVC). It shall be surrounded by a geotextile fabric conforming to Table II of Section 845.02. The core of the panel shall be chemically resistant to petroleum based chemicals, as well as naturally occurring soils. The panel drain shall have an inside cross-sectional thickness from 13 to 25 mm and a depth of from 300 to 450 mm.

B. Acceptance. The open area on the side of the core used for drainage shall be no less than 5 percent of the total core area in accordance with Drawing No. 1. The compressive strength of the core shall be no less than 138 kPa at 10 percent strain as determined by Standard Test Method ASTM D 1621. The cross-sectional area of the core shall not decrease more than 10 percent under a 103 kPa vertical load and the core shall not deflect more than 5 percent along the vertical axis (as installed) as determined by KM 64-XXX-92. In addition, the cross-sectional area available for water flow shall not be less than 3870 square mm under a 103 kPa vertical load when tested in accordance with KM 64-XXX-92.

III. CONSTRUCTION REQUIREMENTS

A. Inspection, Handling, and Storage. The prefabricated edge panel drain, and fittings shall be inspected upon receipt at the job site. The shipment shall be inspected for conformance to product specifications, contract documents, and checked for damage. Damaged or deformed material shall be removed from the job site. The material shall be stored to prevent damage. The material shall be stored away from exposure to ultraviolet light and direct sunlight.

B. Installation of Edge Drain. The prefabricated edge panel drain shall be installed in a trench as shown on Drawing No. 2 and 3. The prefabricated edge panel drain shall be installed on the shoulder side of the trench. A clean neat edge shall be cut in the existing bituminous pavement before excavating the trench. The top of the panel shall not be installed in a position higher than the center point of the

existing pavement. When the panel is installed above this point it shall be removed and replaced at the Contractor's expense. Panel designs that are not symmetrical about the vertical axis when installed shall be installed with the rigid or semi-rigid back facing the sand backfill.

Splices, when required, shall be made prior to placing the panel drain in the trench. Splices shall be made using splice kits furnished by the manufacturer and in accordance with the manufacturer's written instructions. Assembly of joints shall not damage the panel and shall not impede the open flow area of the panel, and retain the vertical and horizontal alignment of the drain. The joints shall prevent infiltration of the backfill or any fine material.

The prefabricated edge panel drain shall be connected to outlet pipes before the trench is backfilled. The trench shall be backfilled with a natural sand that has a gradation conforming to subsection 804.03.02. The sand shall be dried in a hot-mix bituminous plant drier or by similar means so that the sand is free flowing.

Means shall be provided to hold the prefabricated edge panel drain flush against the trench wall during sand backfilling. The sand may be slurried into the trench in one pass with a water application rate of approximately 3.5 litres per 300 mm of trench. The Contractor shall gauge the water supply. The Engineer will record the gauge reading at least once per 150 m of trench.

The final elevation of the sand backfill shall be at least 25 mm above the top of the prefabricated edge panel drain. When this requirement is not met, the Contractor shall slurry in additional sand.

C. Installation of Edge Drain Outlets. Outlets shall be constructed at the locations shown on the plans or as directed by the Engineer. Outlet fittings to transition from the prefabricated edge panel drain to a non-perforated 102-mm smooth lined rigid pipe shall be furnished by the manufacturer, and shall be installed in accordance with the manufacturer's written instructions. The connection of the prefabricated edge panel drain to an outlet pipe shall be made with a 45-degree elbow and bending of the panel drain shall not be permitted. At the sags of vertical curves, the prefabricated edge drain panel may be connected to the outlet pipe with a tee connector. The connection from the prefabricated edge drain panel to the outlet pipe shall be securely connected without impeding the flow.

The outlet pipe leading to the headwall from the prefabricated pavement edge drain panel shall be one of the following alternates:

- 1) Corrugated Polyethylene Pipe Type S, meeting the requirements of AASHTO M 252.
- 2) PVC pipe meeting the requirements of either ASTM D 1785 for schedule

40 or ASTM D 2241 for SDR 17.

- 3) Corrugated steel or corrugated aluminum pipe meeting the requirements specified in Section 705.
- 4) Ribbed PVC pipe meeting the requirements of ASTM F 794 Series 46.
- 5) Corrugated PVC pipe meeting the requirements of ASTM F 949.

The outlet pipe which is chosen by the contractor from the five alternates shall also be precast into the headwall to allow for a smooth transition from the outlet to the headwall. Headwalls not utilizing one of the five alternates are not acceptable and will be removed at the contractors expense.

All outlet pipe shall be 100-mm diameter, unless otherwise noted on the plans or in the proposal. Care shall be exercised to prevent sags, tears, or compression in the outlet pipes. Trenches excavated for outlet pipes shall be backfilled with dense-graded aggregate.

The outlet pipe shall be installed at a desired 4 percent grade, or 3 percent minimum to insure positive outflow.

All material removed from the trench which is not used for other purposes required by the contract or as specified or permitted by the Engineer, shall be removed from the project site at no additional cost to the Department.

For those situations where guardrail will be attached to a structure, such as a bridge end or a pier, the placement of the outlet pipe shall be adjusted such that the guardrail posts will not be driven within a horizontal distance of not less than 300 mm of the outlet pipe for prefabricated pavement edge panel drains.

Where guardrail is not attached to a structure, the placement of the guardrail posts and/ or the outlet pipe shall be adjusted such that the guardrail posts are not driven within a horizontal distance of not less than 300 mm of the outlet pipe for prefabricated pavement edge panel drains.

The Contractor shall mark the location of the outlet pipe for prefabricated edge panel drains with paint or by other means as approved by the Engineer.

Damage to the outlet pipe for prefabricated pavement edge panel drains by guardrail installation shall be acceptably repaired or the damaged outlet pipe shall be removed and replaced by the Contractor, at no additional cost to the Department.

The outlet pipe headwall shall conform to Standard Drawing No. RDP-010-04. The pipe used in the headwall shall conform to the outlet pipe. The site for the headwall shall be undercut by 200 mm and backfilled with DGA. The DGA shall be mechanically compacted to achieve maximum density. The prepared surface for the

headwall shall be constructed so that the after placement of the headwall that the headwall slopes 13 mm per 300 mm for positive outlet flow from the headwall. If settlement occurs in the headwall prior to final inspection, the contractor shall reset the headwall at his expense. The headwall shall also have a minimum of 150 mm of freeboard from the base of the headwall trough to the bottom of the ditch.

In addition to the requirements of Standard Drawing No. RDP-010-04, a quantity of Crushed Aggregate Size No. 2 as conforming to Section 805 shall be used at all pavement subsurface drainage pipe headwall outlets. The Crushed Aggregate Size No. 2 shall be placed a minimum depth of 100 mm. The stone shall be placed a lateral distance of 0.6 m from the sides and the top of the headwall and for a distance of 1.2 m from the toe of the headwall.

Dense Graded Aggregate (DGA) removed to allow placement of the Crushed Aggregate Size No. 2 shall be used to dress existing shoulders where DGA is exposed. Other material removed to allow placement of the Crushed Aggregate Size No. 2 shall be disposed of as directed by the Engineer. No direct payment will be allowed for disposal of removed material.

D. Inspection of Edge Drain Mainline and Outlet. The final product will be inspected using a borescope and mini camera. The outlet pipe shall be inspected with a mini camera. The outlet pipe shall not be deflected greater than 5 percent, and shall be free of tears, debris, and sags.

The pavement edge drain and the outlet pipe shall be inspected (by State or contract personnel supervised by the Resident Engineer) using a borescope or miniature pipeline inspection camera. The panel shall be flush against the wall of the trench and placed at the designated height. The panel shall not be bent, J'd, or damaged in any fashion that would reduce flow. The geotextile fabric surrounding the drain shall be free of rips or punctures. When the panel or the outlet pipe is not properly installed, the panel or the outlet shall be removed and replaced at the Contractor's expense.

E. Adjustment of Quantities. The Engineer reserves the right to make increases or decreases in the quantity of prefabricated edge panel drain constructed as may be required, in accordance with Section 104.02

IV. METHOD OF MEASUREMENT AND BASIS OF PAYMENT

The prefabricated edge panel drain will be measured linearly in meters complete and accepted in the final work. Payment for the accepted quantity at the contract unit price for prefabricated edge panel drain will be full compensation for prefabricated edge panel drain trench excavation; backfill, including dried natural sand and water; furnishing and installing all prefabricated edge panel drain materials, including splices and fittings; and all equipment, labor, and incidentals necessary to complete the work.

Outlet pipe, outlet pipe headwall, bituminous mixtures, and other items required by the contract will be measured and paid for as specified elsewhere in the contract.

The contract unit price for Crushed Aggregate Size No. 2 will be full compensation for all materials, labor, and other incidentals necessary to place Crushed Aggregate Size No. 2 for control of vegetation and erosion at prefabricated pavement edge panel drain outlet pipe headwalls.

TYPICAL PREFABRICATED EDGE PANEL DRAIN DESIGN

CROSS SECTION

66

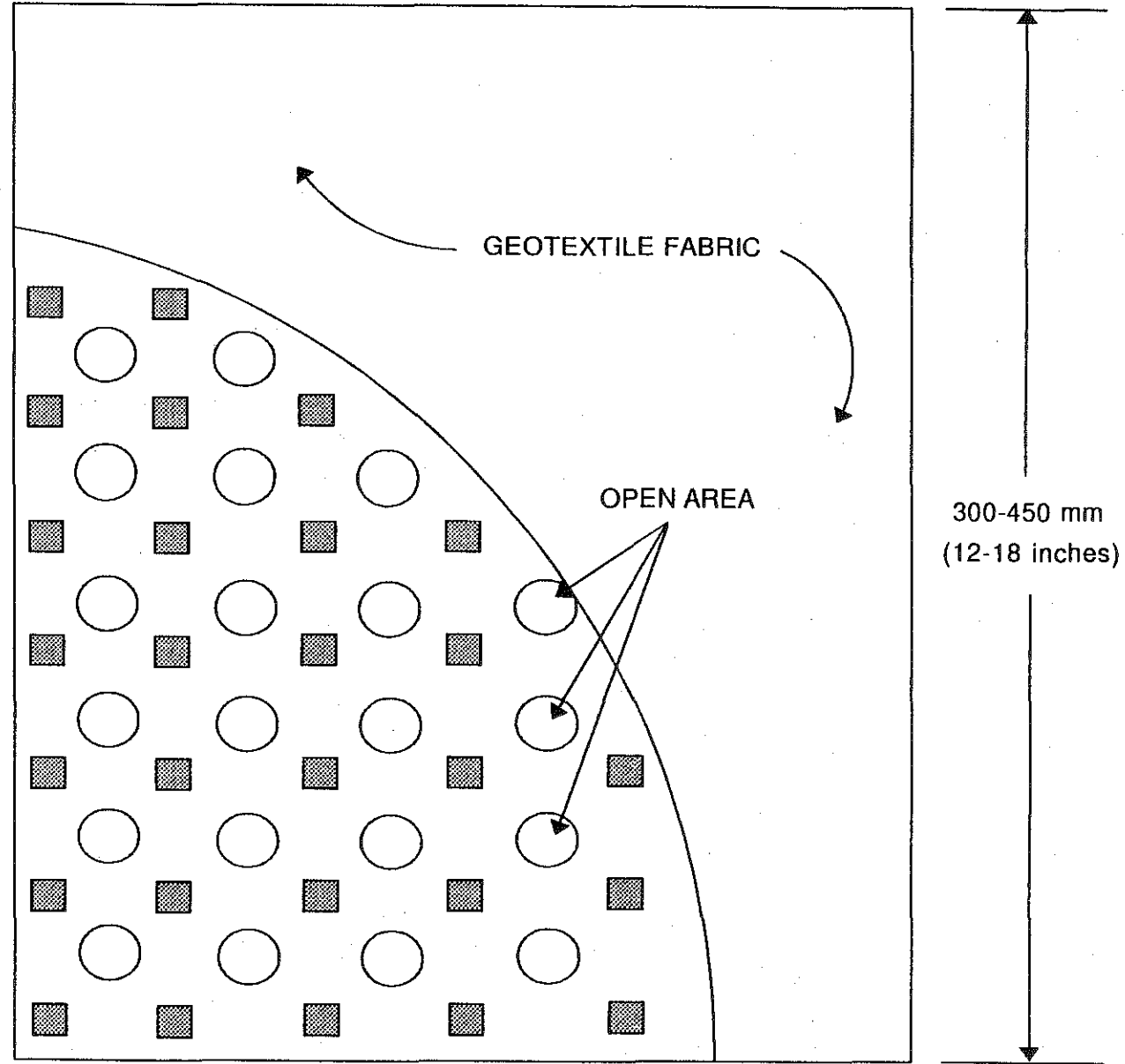
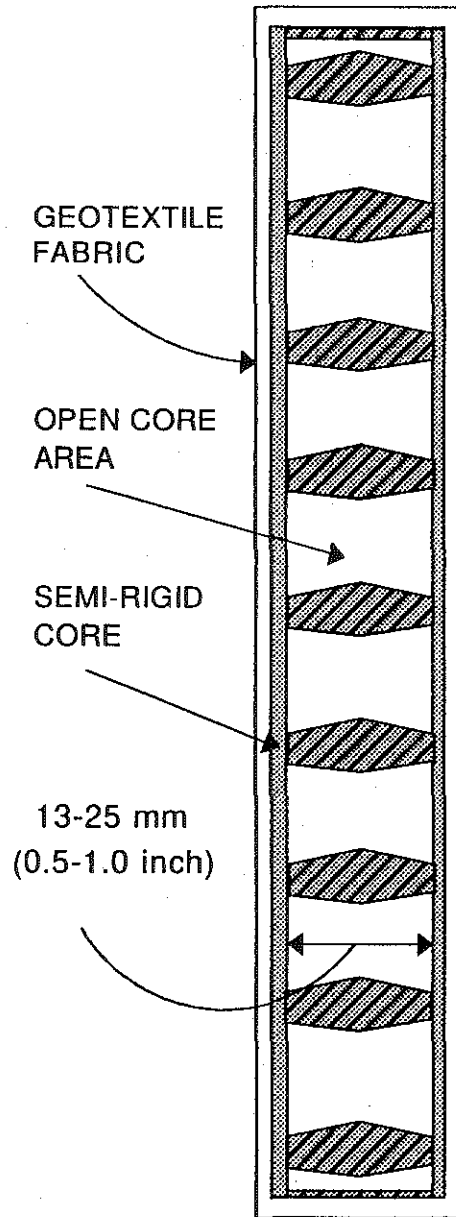

DRAWING NO. 1

TYPICAL DETAIL FOR INSTALLATION OF PREFABRICATED PAVEMENT EDGE PANEL DRAINS

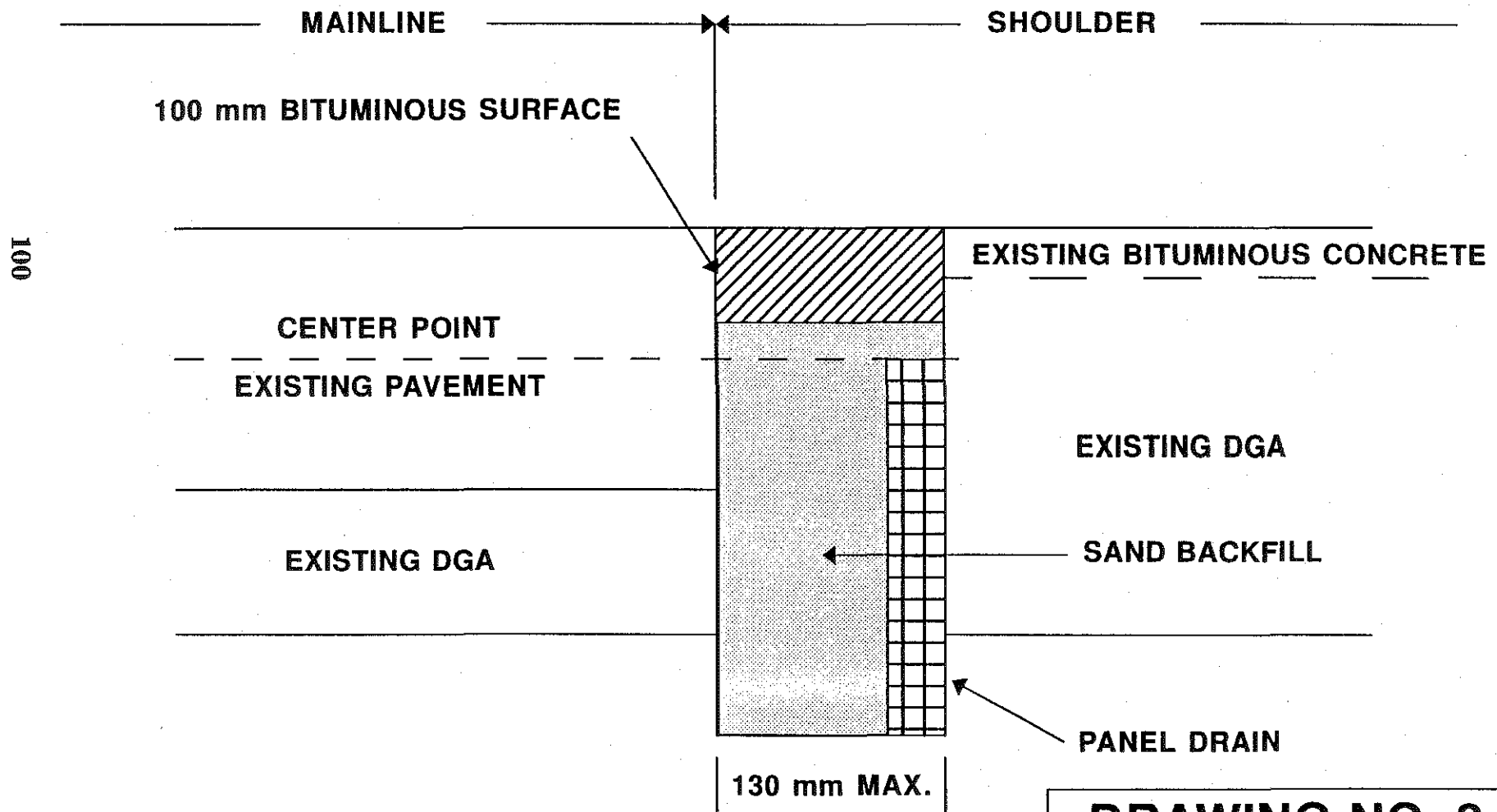

DRAWING NO. 2

LONGITUDINAL PAVEMENT EDGE DRAIN (PANEL DRAIN)

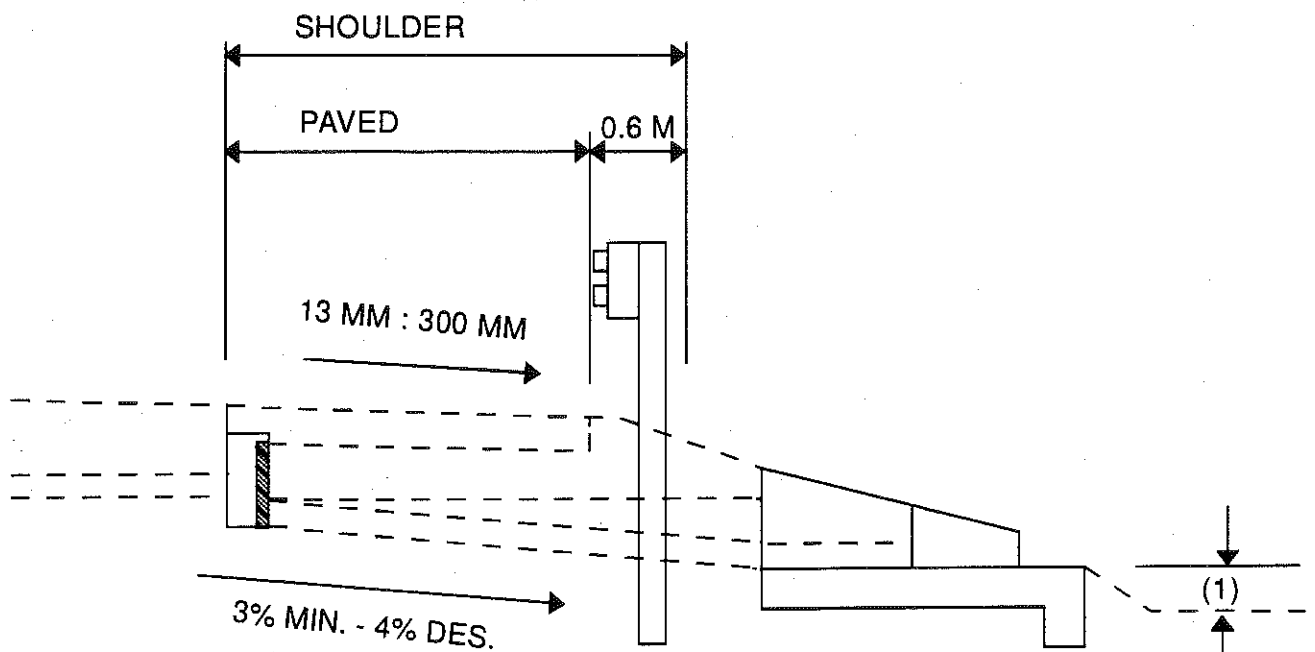

(1) 150 MM MINIMUM FREEBOARD TO THE BOTTOM OF THE DITCH

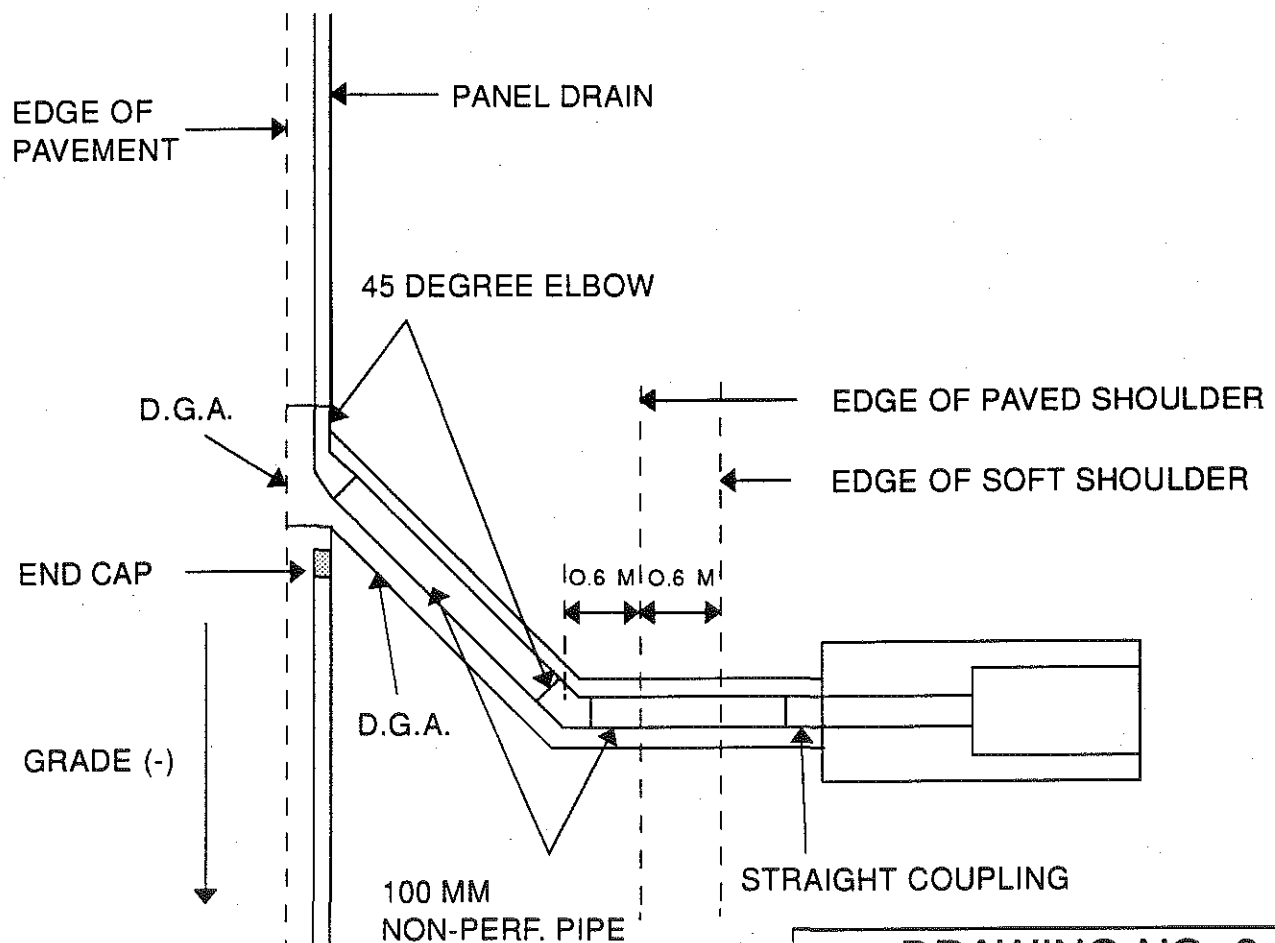

101

DRAWING NO. 3

VERTICAL COMPRESSION TEST OF PAVEMENT EDGE PANEL DRAINS
Kentucky Method
64-XXX-92

VERTICAL COMPRESSION TEST OF PAVEMENT EDGE PANEL DRAINS

1. SCOPE -

1.1 This method covers a procedure for determining the behavior of pavement edge panel drains in vertical compression, when encapsulated in a natural sand backfill. The test measures the loss of core volume.

1.2 Application - This method shall apply to all panel or fin-type pavement edge drains. This may include but not be limited to all cusped types, those types with posts, types that are similar to deformed pipe, and any other design.

2. APPARATUS -

2.1 Compression Machine - A compression machine that is capable of at least 454 kg. The machine must be capable of loading at a rate of 45 kg per minute, and maintaining a constant load for an indefinite period.

2.2 A Compression Box - The box must be capable of holding the specimen and sand backfill, and it must be capable of supporting a minimum vertical load of 450 kg. The design of the box shall conform to the attached Figure 1.

2.3 Clear plastic spacers (shown and described in Figure 2). These are used to protect the tempered glass ends of the compression box from scratches.

2.4 Sand - Sufficient sand to fill the compression box. Natural sand is recommended. The sand shall have a gradation conforming to subsection 804.03.01 of the Kentucky Standard Specifications for Road and Bridge Construction (1991 Edition).

2.5 Tracing Paper - The paper must be suitable for tracing and have a minimum size of 220 mm by 350 mm.

2.6 Light Source - Any strong light source is acceptable.

2.7 A 3.75 liter container.

2.8 Planimeter - This is to calculate loss of core area after test. If computer digitizing equipment is available, this may be used in lieu of the planimeter.

2.9 Length Measuring Device - A minimum range of 450 mm, and a precision

of 1.00 mm.

3. SAMPLE -

3.1 The sample core shall be approximately 300 mm in height and 300 mm in length.

3.2 If the sample to be tested is 450 mm in height, the sample shall be cut to 300 mm.

3.3 When sampling, the geotextile shall be cut approximately 6.00 mm longer than the core (at both ends of the core).

3.4 The geotextile covering the core shall be intact. There shall not be any tears or punctures, and if the textile is normally glued to the core for a particular design, it shall remain glued for this test.

4. PROCEDURE -

4.1 The plastic spacers are placed next to the tempered glass ends of the box. This helps to prevent the sand from scratching the glass ends. The plastic spacers may be considered expendable since it may become necessary to replace them after several tests, due to scratching by the sand.

4.2 The sample is placed in an upright position in the compression box, against one sidewall of the box.

4.3 The 6.00 mm excess geotextile at the ends of the core shall be lapped as shown in Figure 2. This helps to prevent sand from flowing between the end of the core and the glass endwall.

4.4 Pour the dry sand into the compression box to a height of at least 100 mm above the top of the core of the panel. Make no attempt to densify the sand.

4.5 Smooth the surface of the sand to make it as level as possible.

4.6 Place the loading plate (Figure 1) onto the sand surface, and then place the entire compression box into the testing machine.

4.7 With the scale, measure accurately and record the height of the panel core.

4.8 With the light source shining through the open core from one glass end of the compression box, place a piece of tracing paper on the opposite end of the box and trace the open area of the core.

4.9 Begin loading the sand backfill and core at a rate of 45 kg per minute. When the load has reached 113 kg, hold the load constant, measure the height of the core, and repeat Step 4.8.

4.10 After Step 4.9 is completed, continue loading the sample at the same rate designated in Step 4.9 until the load reaches 227 kg. Repeat Step 4.8. Repeat the same procedures when the load reaches 340 kg and 454 kg.

4.11 Remove the compression box from the testing machine. Remove the sand, the sample, and the plastic spacers.

4.12 Flush all of the remaining sand from the compression box. Use liberal amounts of water.

CAUTION: DO NOT WIPE THE GLASS ENDS WITH A CLOTH OR PAPER TOWEL UNTIL CERTAIN ALL SAND HAS BEEN REMOVED, AS THIS WILL SCRATCH THE GLASS.

4.13 Completely dry the interior of the compression box.

4.14 Repeat Steps 4.1 through 4.4 with a fresh sample.

4.15 Densify the sand by pouring 3.75 litres of water into the box and wait until all of the free water has drained from the box. This may take several minutes.

4.16 Repeat Steps 4.5 through 4.13.

5. CALCULATIONS -

5.1 The decrease in the area of the core with increasing load, and the decrease in the height of the core are calculated.

5.2 Determine vertical stress on the horizontal sand surface (located under the immediately under the loading plate) at each load level as follows:

$$\text{Stress} = (\text{load}) / (\text{Area of sand surface}).$$

For Example:

$$\text{Stress} = (1.112 \text{ kN}) / (0.0284 \text{ m}^2) = 39.15 \text{ kPa}$$

5.3 From the tracing made at each load level, use planimeter or digitizing equipment to determine open area of core at each load level. This is to be done

for the dense (wet) and loose (dry) sand tests.

5.4 Determine the percent change in area of the core at each load level (for dense and loose sand) as follows:

$$A_D = [(A_0 - A_L) / (A_0)] \times 100$$

where

A_D = Change in area (percent),
 A_0 = Initial area at zero load, and
 A_L = Area at a particular load.

5.5 Determine percent change in core area between dense and loose sand at each load level as follows:

$$A_C = [(A_{DL} - A_{LL}) / (A_{DL})] \times 100$$

where

A_C = Change in core area between dense and loose sand (percent),
 A_{DL} = Area of core for dense sand at a particular load, and
 A_{LL} = Area of core for loose sand at a particular load.

5.6 Plot percent change in core area (A_D) as a function of stress for each load level and both dense and loose sand.

5.7 Plot percent change in core area between dense and loose sand (A_C) as a function of stress at each load level.

5.8 Calculate percent change in height as follows:

$$H_D = [(H_i - H_f) / (H_i)] \times 100$$

where

H_D = Change in height (percent),
 H_i = Initial height of core, and
 H_f = Final height of core.

5.9 Plot percent change in height (H_D) as a function of stress at each load level.

6. REPORT -

6.1 Report the percent change in core area at a stress level of 100 kPa for dense sand.

6.2 Report the percent change in core area at a stress level of 100 kPa for loose sand.

6.3 Report the percent change in core area between dense and loose sand at a stress level of 100 kPa.

6.4 Report the percent change in height of the core at a stress level of 100 kPa.

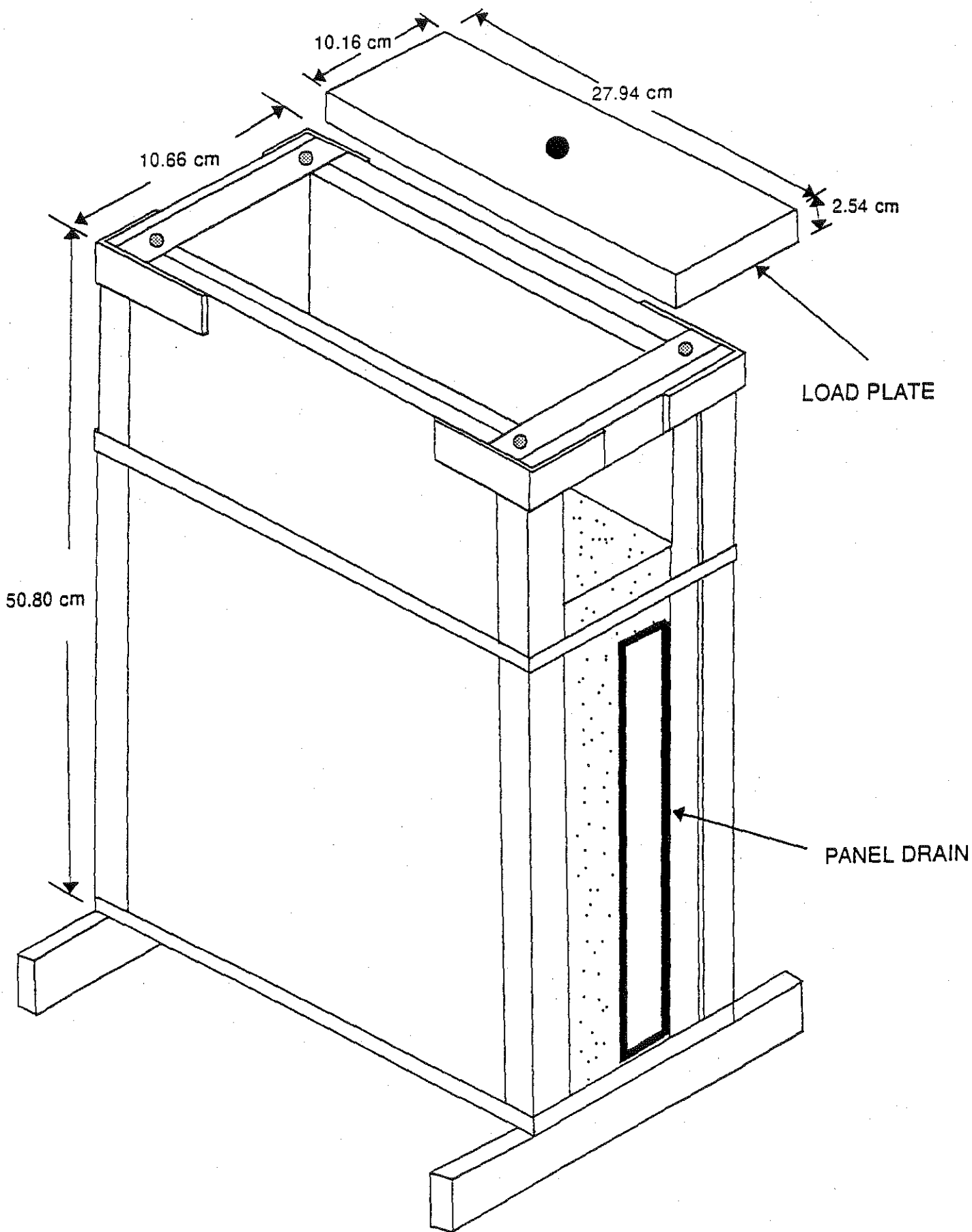

FIGURE 1. EDGE DRAIN COMPRESSION CHAMBER

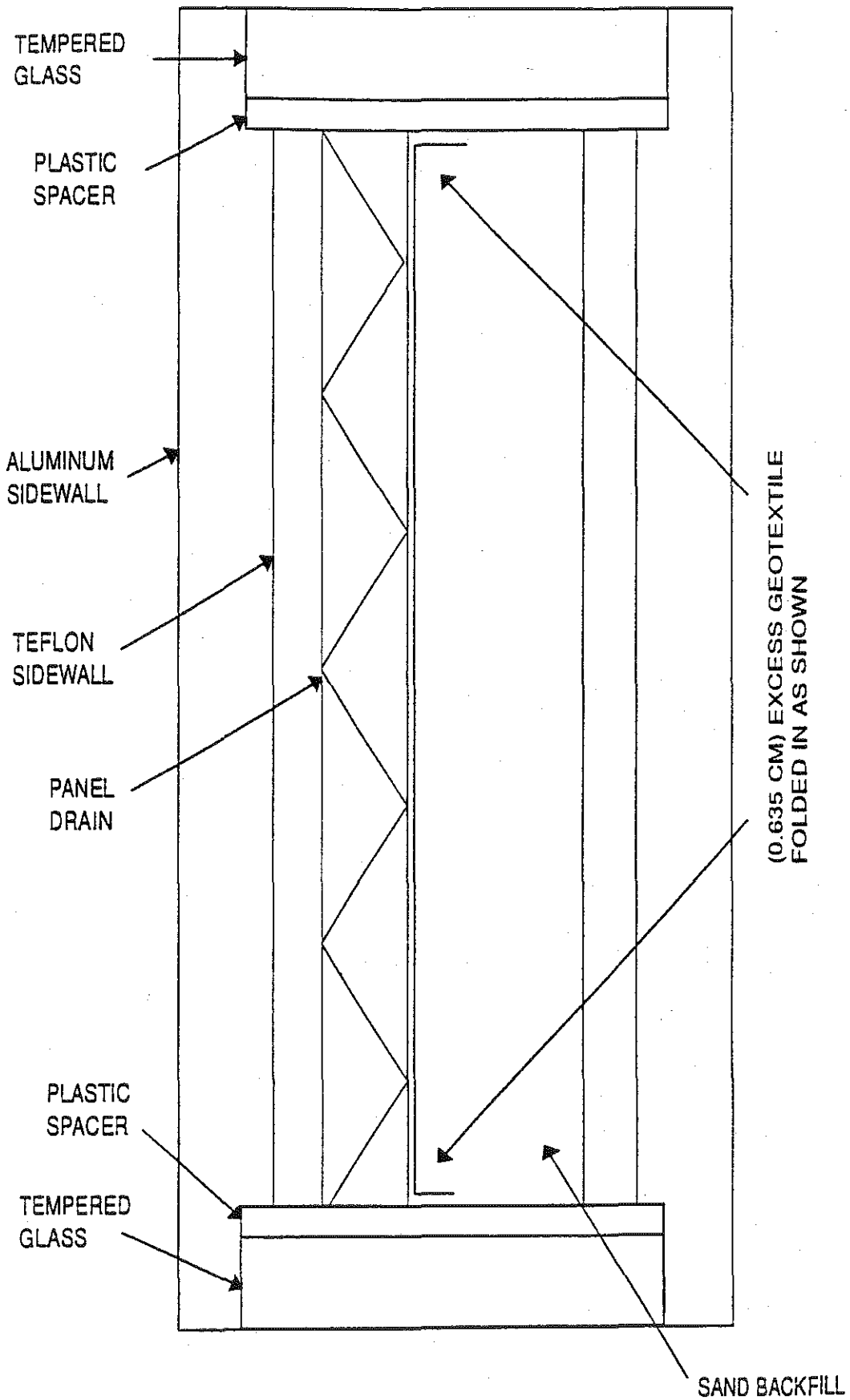

FIGURE 2. TOP VIEW OF COMPRESSION CHAMBER

