

Research Report
KTC-97-5

PERFORMANCE AND COST EFFECTIVENESS
OF PAVEMENT EDGE DRAINS

by

L. John Fleckenstein
Senior Research Investigator

and

David L. Allen
Chief Research Engineer

Kentucky Transportation Center
College of Engineering
University of Kentucky
Lexington, Kentucky

in cooperation with
Transportation Cabinet
Commonwealth of Kentucky

and

Federal Highway Administration
U.S. Department of Transportation

The contents of this report reflect the views of the authors who are responsible for the facts and accuracy of the data presented herein. The contents do not necessarily reflect the official views or policies of the University of Kentucky, the Kentucky Transportation Cabinet, nor the Federal Highway Administration. This report does not constitute a standard, specification, or regulation. The inclusion of manufacturer names and trade names are for identification purposes and are not to be considered as endorsements.

March 1997

1. Report No. KTC-97-5	2. Government Accession No.	3. Recipient's Catalog No.	
4. Title and Subtitle Performance and Cost Effectiveness of Pavement Edge Drains		5. Report Date March 1997	6. Performing Organization Code
7. Author(s) L. John Fleckenstein and David L. Allen		8. Performing Organization Report No.6 KTC-97-5	
9. Performing Organization Name and Address Kentucky Transportation Center College of Engineering University of Kentucky		10. Work Unit No. (TRAI5)	11. Contract or Grant No.
12. Sponsoring Agency Name and Address Kentucky Transportation Cabinet State Office Building		13. Type of Report and Period Covered Final	14. Sponsoring Agency Code
15. Supplementary Notes Publication of this report was sponsored by the Kentucky Transportation Cabinet with the			
16. Abstract It is apparent from research conducted under this study that edge drains increase subgrade strength through the removal of water. It is also apparent in most cases that the edge drains increase pavement life by approximately seven years. Current cost benefit analysis indicates that edge drains can provide a cost savings of approximately \$200,000 dollars a mile over the life of the pavement. Research also indicates that if edge drains are not properly installed and maintained they can do more damage then good. It is evident that edge drains should be inspected with a pipeline camera prior to final acceptance and prior to rehabilitation.			
17. Key Words Edge Drain Inspection Subgrade Moisture Performance		18. Distribution Statement Unlimited	
19. Security Classif. (of this report)	20. Security Classif. (of this page)	21. No. of Pages 61	22. Price

* SI is the symbol for the International System of units. Appropriate rounding should be made to comply with Section 4 of ASTM E330. Rev. 12/93

SI (MODERN METRIC) CONVERSION FACTORS									
APPROXIMATE CONVERSIONS TO SI UNITS					APPROXIMATE CONVERSIONS FROM SI UNITS				
Symbol	When You Know	Multiply By	To Find	Symbol	Symbol	When You Know	Multiply By	To Find	Symbol
LENGTH					LENGTH				
in.	inches	25.40000	millimeters	mm	mm	millimeters	0.03937	inches	in.
ft	feet	0.30480	metres	m	m	metres	3.28084	feet	ft
yd	yards	0.91440	metres	m	m	metres	1.09361	yards	yd
mi	miles	1.60934	kilometres	km	km	kilometres	0.62137	miles	mi
AREA					AREA				
in. ²	square inches	645.16000	millimetres squared	mm ²	mm ²	millimetres squared	0.00155	square inches	in.
ft ²	square feet	0.09290	metres squared	m ²	m ²	metres squared	10.76392	square feet	ft
yd ²	square yards	0.83613	metres squared	m ²	m ²	metres squared	1.19599	square yards	yd
ac	acres	0.40469	hectares	ha	ha	hectares	2.47103	acres	ac
mi ²	square miles	2.58999	kilometres squared	km ²	km ²	kilometres squared	0.38610	square miles	mi
VOLUME					VOLUME				
fl oz	fluid ounces	29.57353	millilitres	ml	ml	millilitres	0.03381	fluid ounces	fl oz
gal.	gallons	3.78541	litres	l	l	litres	0.26417	gallons	gal.
ft ³	cubic feet	0.02832	metres cubed	m ³	m ³	metres cubed	35.31448	cubic feet	ft ³
yd ³	cubic yards	0.76455	metres cubed	m ³	m ³	metres cubed	1.30795	cubic yards	yd ³
MASS					MASS				
oz	ounces	28.34952	grams	g	g	grams	0.03527	ounces	oz
lb	pounds	0.45359	kilograms	kg	kg	kilograms	2.20462	pounds	lb
T	short tons (2000 lb)	0.90718	megagrams	Mg	Mg	megagrams	1.10231	short tons (2000 lb)	T
FORCE AND PRESSURE					FORCE				
lbf	pound-force	4.44822	newtons	N	N	newtons	0.22481	pound-force	lbf
psi	pound-force per square inch	6.89476	kilopascal	kPa	kPa	kilopascal	0.14504	pound-force per square inch	psi
ILLUMINATION					ILLUMINATION				
fc	foot-candles	10.76426	lux	lx	lx	lux	0.09290	foot-candles	fc
fl	foot-Lamberts	3.42583	candela/m ²	cd/m ²	cd/m ²	candela/m ²	0.29190	foot-Lamberts	fl
TEMPERATURE (exact)					TEMPERATURE (exact)				
°F	Fahrenheit temperature	5(F-32)/9	Celsius temperature	C	°C	Celsius temperature	1.8C + 32	Fahrenheit temperature	F

EXECUTIVE SUMMARY

It is apparent from research conducted under this study that edge drains increase subgrade strength through the removal of water. It is also apparent in most cases that the edge drains increase pavement life by approximately seven years. Current cost benefit analysis indicates that edge drains can provide a cost savings of approximately \$200,000 dollars a mile over the life of the pavement. Research also indicates that if edge drains are not properly installed and maintained they can do more damage than good. It is evident that edge drains should be inspected with a pipeline inspection camera prior to final acceptance and prior to rehabilitation.

TABLE OF CONTENTS

INTRODUCTION	1
FIELD INVESTIGATIONS	1
LABORATORY TESTING	3
LIFE-CYCLE COST ANALYSIS OF EDGE DRAINS	3
RECOMMENDATIONS	5
APPENDIX A (Data Input and Output from “Pavement Life-Cycle Cost Analysis)	28
APPENDIX B (Proposed Specification for Pavement Edge Drain Installation in Kentucky) . .	35

LIST OF FIGURES

- Figure 1. Partially blocked outlet in bottom of drop box (Mountain Parkway).
- Figure 2. Edge drain outlet cut into drop box (no rodent screen).
- Figure 3. No. 2 stone placed around headwall.
- Figure 4. Recommended headwall design.
- Figure 5a. Construction photo of single wall pipe coming out of headwall.
- Figure 5b. Partially crushed outlet on back side of outlet.
- Figure 5c. Rip in single wall pipe, back side of headwall.
- Figure 6. Outlet pipe being backfilled on Interstate 64.
- Figure 7a. Outlet pipes damaged during raising of the shoulder.
- Figure 7b. Outlet pipes crushed prior to headwall placement.
- Figure 8. Improper use of outlet "T" connectors on slope.
- Figure 9. Recommended "Y" connector in place of "T" connector and recommended outlet spacing at sags.
- Figure 10. Loop outlet system design.
- Figure 11. Photo of modified "T" connector.
- Figure 12. Buried headwall and guardrail post driven through outlet pipe.
- Figure 13. Headwall installed in shallow ditch line.
- Figure 14a. Water ponding in ditch line due to soil slide in unstable cut.
- Figure 14b. Recommended ditch drain.
- Figure 15. Recommended edge drain flow capacity.
- Figure 16. Water standing in sand backfill under pipe.
- Figure 17. Settlement in edge drain trench due to traffic being forced onto the shoulder.
- Figure 18a. Bridge end drainage being installed.
- Figure 18b. Spike driven through perforated pipe.
- Figure 19a. Headwall trough clogged with grass.
- Figure 19b. Clogged rodent screen.
- Figure 19c. Partially clogged outlet pipe.
- Figure 20a. Signs of water induced failure in asphalt pavement.
- Figure 20b. Signs of improper functioning edge drains.
- Figure 21a. KTC personnel preparing to inspect outlets on I-275.
- Figure 21b. Totally crushed round pipe edge drain on I-264.
- Figure 22. Outlet location marked with delineator post.
- Figure 23. Recommended drainage task group.

INTRODUCTION

The State of Kentucky has been installing longitudinal edge drains (round pipe) since the mid 70's and panel drains since 1985. The Kentucky Transportation Center has been actively involved in evaluating the installation and field performance of these systems since the mid 80's.

A study was initiated in 1991 to evaluate pavement edge drains and quantify their effects on overall pavement performance. The general objectives of this study were :

- (1) To quantify the major in-service problems of the longitudinal edge drains and their outlets such as blinding of fabric, clogging of the panel cores, and clogging of the round pipe, and to evaluate past and current construction practices,
- (2) To develop a generic specification for highway edge drains,
- (3) To determine the lateral effectiveness of edge drain systems across the pavement structure,
- (4) To verify that longitudinal edge drains improve pavement performance, and
- (5) To determine the cost effectiveness of longitudinal edge drains.

An interim report (KTC-94-20) entitled "Evaluation of Pavement Edge Drains and Their Effect on Pavement Performance" was published in September 1994. That report addressed Objectives 1 - 4, and presented preliminary cost effectiveness data for Objective 5. Since the issue of the interim report in 1994, a significant amount of laboratory testing, additional analysis of the cost benefits of edge drains, and field inspections has been performed. The objective of this report is to present the additional information and to make final recommendations for the draft edge drain specification developed under this study.

FIELD INVESTIGATIONS

The Kentucky Transportation Center and the Kentucky Department of Highways have been actively researching the field performance of edge drain systems for over 12 years, and approximately 13 research reports have been written documenting the results. These reports include:

"Construction and Performance Evaluation of a Geocomposite Pavement Edge Drain Including Comparison with a 4-Inch Pipe Drain," Research Report UKTRP-87-17, July 1987.

"Evaluation of Hydraway Edge Drain on Pennyriple Parkway," Research Report UKTRP-88-15, July 1988.

"Evaluation Of Hydraway and Advanedge Edge Drains on the Mountain Parkway," Research Report KTC-89-33, May 1989.

“Analysis of Edge Drains on Western Kentucky Parkway (Milepost 83 to Milepost 90),” Research Report KTC-89-46, September 1989.

“Mountain Parkway Edge Drain Inspection (September 29-October 5, 1989),” Research Report KTC-89-50, October 1989.

“Construction and Performance Evaluation of Geocomposite Pavement Edge Drains Hydraway and Akwadrain”, Research Report KTC-89-51, October 1989.

“Evaluation of Geocomposite Pavement Panel Drains Installed in a Sand Backfill under Revised Installation Specification, Research Report KTC-90-25, August 1991.

“Evaluation of Headwalls and Outlets for Geocomposite Edge Drains on Interstate 75 and Interstate 71 in Kentucky” Research Report KTC-91-10, August 1991.

“Construction Evaluation of Hydraway Edge Drain and Outlet Pipes on Interstate 64”, Research Report KTC-91-19, December 1991.

“Evaluation of Pavement Edge Drains and the Effect on Pavement Performance,” Research Report KTC-94-20, September 1994.

“Evaluation of Edge Drains on Pennyryle Parkway, Webster County,” Research Report KTC-96-11, May 1996.

“Evaluation of Edge Drains on I-81, in Roanoke, Virginia,” Research Report KTC-96-12, July 1996.

“Evaluation of Edge Drains on Interstate 64, Fayette, Scott, and Woodford Counties,” Research Report KTC-96-17, July 1996.

As a result of this research, Kentucky has made several modifications in the design and construction of edge drain systems. Modifications have included: sand backfill around panel drains, double-wall outlet pipe, closer headwall spacings, and etc. These modifications have immensely improved the performance of these systems but problems are still occurring. It is evident from the comments of other state and federal agencies that Kentucky has developed one of the better edge drain specifications. It is also evident from past and recent research that some modifications need to be incorporated into the new specification.

In 1996, the Kentucky Transportation Center investigated the performance of four projects in the State of Kentucky and one project for the Virginia Department of Transportation. These projects included: 1) Pennyryle Parkway in Webster County, 2) Watterson Expressway, 3) Interstate 64 in Fayette, Scott, and Woodford Counties, 4) Interstate 275, and 5) project borescoping panel drains on Interstate 81, in Roanoke, Virginia for the Virginia Department of Transportation.

During the evaluation of these projects, it was apparent that recurring failures in drainage systems caused by improper construction needed to be addressed. In addition, several failures were occurring from improper headwall design, and improper maintenance practices. (These failures are

further discussed in the final recommendations of this report).

LABORATORY TESTING

In 1993, a new test procedure for testing edge drain panel was introduced in the interim report. The test appears to closely simulate field stress conditions and performance. The vertical compression test simulates the folding, "J'ing", and fabric intrusion that is observed in the field with some of the more open-type panel drains. The vertical compression test indicates the amount of core loss to be expected with different backfill densities, but the expected reduction in flow could not be determined with this test procedure.

A large scale vertical compression chamber was constructed in 1994. The chamber was configured to test an 80-foot long section of panel drain. The panel is placed into a 4-inch wide by 8-foot long channel. The ends are sealed with caulking. The remainder of the panel is backfilled with sand. A 7-foot long load plate is then placed on top of the sand. The flume is set at a 3% grade and a 1-inch head is placed on the panel at the inlet end. The panel is loaded as in the initial vertical compression test. The flow rate of the panel is recorded at each load increment. To date, three brands of panel drains have been tested. These include: Hydraway, Contech, and Advanedge. Preliminary test data indicate that the more open type panel drains (Hydraway, Contech) showed moderate to significant amount of flow reduction with increasing load. The flow rate of the Advanedge panel remained stable under the increasing load (Flow testing data are shown in Figure 15 in the recommendations).

Information derived from the Vertical Compression Test and the Vertical Compression Flow Test indicates that there is likely a strong correlation between the reduction in core area in the dry test and the reduction in flow in the flow test. Test results are further discussed in the recommendations.

LIFE-CYCLE COST ANALYSIS OF EDGE DRAINS

Performance data reported in the interim report on this study (Research Report No. KTC-94-20) indicated that pavements with edge drains had significantly less moisture in the subgrade, the modulus of the subgrade was substantially higher, and that, on average, the pavement life was approximately seven years longer. A very preliminary cost analysis reported in that report indicated that edge drains are cost effective and that the average cost savings were approximately \$25,000 per 1.6 km (1.0 mile). However, that analysis included only seven rigid pavement sections. Furthermore, maintenance costs, user delay costs, and rehabilitation costs were not included in that analysis.

Subsequent to the analysis in that report a more detailed life-cycle cost analysis was performed. Performance data from 500 rigid pavement sections in Kentucky were obtained from the performance database maintained by the Pavement Management Branch of the Kentucky Department of Highways. Performance models were developed for rigid pavement sections with edge drains and for rigid pavement sections without edge drains using modeling techniques developed under a research study entitled "*Pavement Performance Modeling*" (KYHPR-92-147). The resulting models were linear and of the following form:

$$RI = (\text{Initial RI}) - C_i(\text{ESAL's})$$

Where:

RI = Ride Index

ESAL's = number of accumulated Equivalent Single Axleloads, and

C_1 = coefficient resulting from the regression analyses.

For pavement sections without edge drains, coefficient $C_1 = 3.556 \times 10^{-8}$. For pavement sections with edge drains coefficient $C_1 = 2.7028 \times 10^{-8}$. Asphalt pavement sections were not included in the analysis as performance data were not available.

The life-cycle cost analysis was performed using a computer program entitled "LCCA" developed under a research study entitled "Life-Cycle Cost Analysis of Pavement Systems" (KYHPR-87-118). The following parameters were used in the analyses.

Pavement Type = Rigid

Number of Lanes = 4

Design Lane ESAL's = 50,000,000

Analysis Period = 40 years

Design Speed = 97 kph (60 mph)

Maximum Permissible Rut Depth = 12.7 mm (0.5 inch)

Initial RI = 3.5

Critical RI = 2.7

Subgrade CBR = 6

Assumed Traffic Growth = 2% annually

Section Length Used in Analyses = 1.6 km (1.0 mile)

Rigid Slab Thickness = 280 mm (11.0 inches)

DGA Thickness = 152 mm (6.0 inches)

Interest Rate = 7%

Discount Rate = 3%

User Delay Cost

Lane Closure Time = 6 months

Delay Cost per Truck per Hour = \$30

Delay Cost per Automobile per Hour = \$10

Percent Trucks = 23%

Details of the input and output of the analyses are listed in Appendix A.

The analyses indicated that the pavement without edge drains would have required two overlays in the 40-year design life. The first overlay would be necessary in year 21, and 89 mm (3.5 inches) of asphaltic concrete would have been required. A second overlay of 38 mm (1.5 inches) would be required in year 36. This is an effective cost of \$2,283,980 per 1.6 km (1.0 mile).

The pavement with edge drains would require only one overlay in year 27 of the analyses. An asphaltic concrete overlay of 89 mm (3.5 inches) was recommended. This is an effective cost of \$2,073,292 per 1.6 km (1.0 mile). This is a cost savings for the pavement with edge drains of approximately \$210,000 per 1.6 km (1.0 mile).

RECOMMENDATIONS

Twelve years of research and field experience have resulted in the following list of recommendations.

Edge Drain Outlets

1. The outlet pipe should be placed a minimum of 305mm (12 inches) off the bottom of drop box inlets to insure against blockage from debris (Figure 1).
2. Rodent screens should be used on all edge drain outlets, including edge drain outlets at drop boxes and those cut into cross drain headwalls (Figure 2).
3. Continue using No. 2 stone around headwalls. The stone decreases vegetation growth, decreases erosion below the headwall, and decreases the frequency of maintenance (Figure 3).
4. Headwalls should be redesigned including: A) moving the centroid forward to eliminate backward tilting, B) build a slope into headwall trough, C) raise the outlet above the trough of the headwall, D) precast landfill grade double-wall, smooth-line polyethylene pipe (Pipe stiffness 71-72) into the headwall (Figure 4) or oversize a hole in the headwall for the outlet pipe to slide into or through.. Either way this would eliminate the coupling on the backside of the headwall.
5. Landfill grade double-wall, smooth-line polyethylene pipe should be used for edge drain outlet pipe (Pipe stiffness of 71-72) and in the headwall (Figure 5a-5c).
6. Outlet pipes should be bedded and backfilled with fine crushed stone, DGA, or flowable fill (Figure 6).
7. The headwall should be attached at the same time that the outlet pipe is being installed (Several outlets were found damaged during construction on Mountain Parkway) (Figure 7a and 7b).
8. "T" connectors should not be permitted on a slope. The capacity of the edge drain system down grade will likely be exceeded (Figure 8).
9. "Y" connectors or dual outlet pipes should be used at sags rather than "T" connectors. It is difficult or impossible to inspect edge drains with "T" connectors. In addition, additional outlets should be placed in sags. An outlet should be placed 15.25m (50 feet) on each side of the outlet at the center of the sag (Figure 9).
10. Consideration should be given to installing a half-loop or open edge drain system. Several states are installing systems in which the up-gradient end of the edge drain is also run to a headwall. This allows the entire edge drain system to be inspected and allows the system to be flushed if needed (Figure 10).

11. Field engineered connectors should be carefully inspected and permitted only by the Resident Engineer (Figure 11).
12. Insure that other subcontractors on a project are aware of the location of the outlet pipes (i.e. guardrail contractors)-(Figure 12).
13. The bottom toe of the headwall should be raised 152 to 304 mm (6 to 12 inches) above the ditch line if possible (Figure 13). If not possible, the ditch line should be further excavated or the headwall distance should be adjusted by the Resident Engineer.
14. Consideration should be given to using perforated pipe drains in the ditch lines (in areas of unstable cut slopes) (Figure 14a). In addition, the edge drain outlet could be tied into the perforated pipe in the ditch line (Figure 14b).

Edge Drains

15. Edge drains should have a minimum capacity that is equal to or greater than 133 liters (30 gallons) per minute. Flow modeling indicates that during maximum rainfall events approximately 0.15 liter (0.04 gallon) per linear foot per minute is reaching the drain. This is equivalent to approximately 75 liters (20 gallons) per minute exiting the drain on a 152 m (500-foot) run. (Figure 15).
16. The edge drain pipe should be placed on the bottom of the excavated trench. (Water appears to stand under the pipe on current installations) (Figure 16).
17. Traffic should not be allowed on top of the trench during construction. If permitted, the edge drain should be inspected and replaced if necessary. (Figure 17).
18. On bridge-end drainage, the edge drains should not be held in place with a spike driven through the pipe. A band should be placed around the pipe (Figures 18a and 18b).

Inspection and Maintenance

19. Clean screens and headwall troughs on a routine basis (Figure 19a - 19c).
20. Inspect, repair, or replace edge drains prior to overlaying distressed pavements (Figure 20a) Investigate areas of obvious edge drain failures (20b).
21. Inspect edge drains with a pipeline camera after construction (prior to final approval). (Figure 21a and 21b).
22. Mark outlet locations with a paint mark on shoulder or with delineator post next to headwall (Figure 22).
23. Form a drainage advisory task group composed of members from planning, design,

construction, and maintenance (Figure 23).

Pavement Drainage

24. The research conducted under this research project has answered several questions regarding the performance and cost effectiveness of these systems. During the course of this project, several other areas of concern were brought to the attention of the authors. This include:

- noticeable stripping occurring in large stone mixes,
- saturated subgrade under the edge drain systems, should drains be installed to intercept the pavement area and further into the subgrade,
- the effectiveness of round pipe verses panel drain in controlling subgrade moisture,
- the effectiveness of bridge end drainage,
- the effectiveness and performance of cross drains,
- long-term performance of edge drains in rubberized pavement sections, and
- need, benefits, and cost of flushing and maintaining edge drain systems.

To date, these items have not been researched or analyzed.

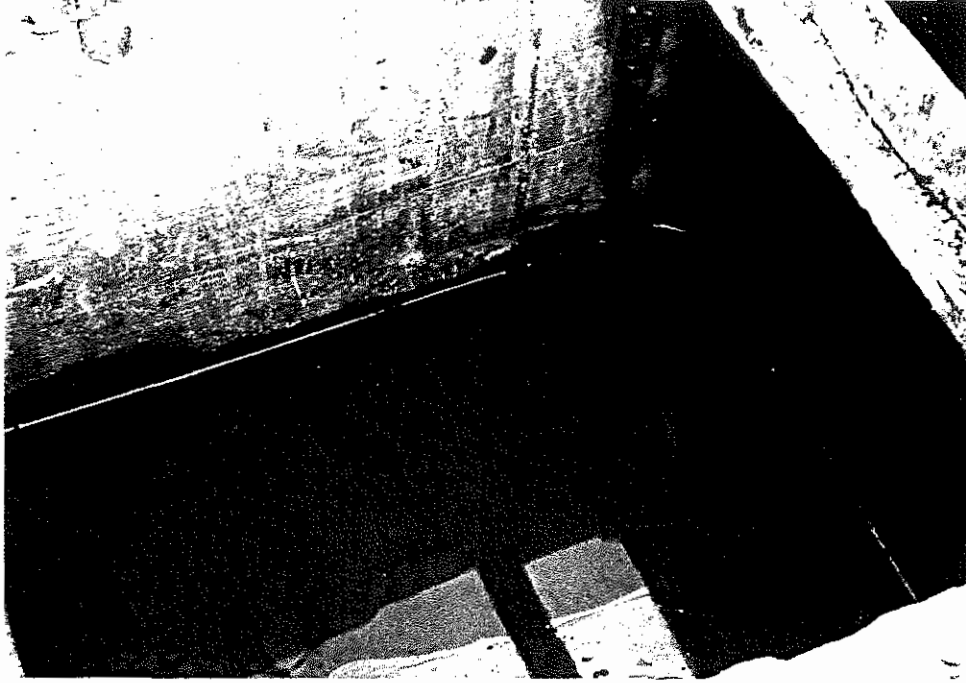

Figure 1. Partially blocked outlet in bottom of drop box (Mountain Parkway).



Figure 2. Edge drain outlet cut into drop box (no rodent screen).



Figure 3. No. 2 stone placed around headwall.

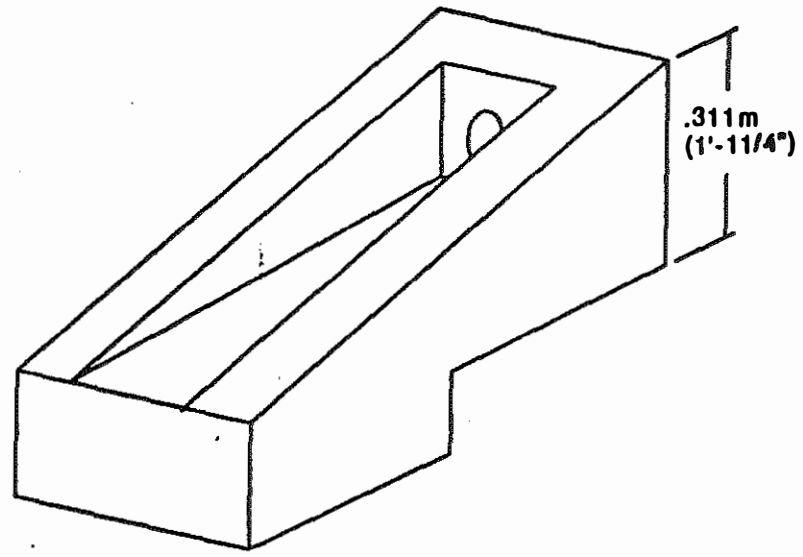
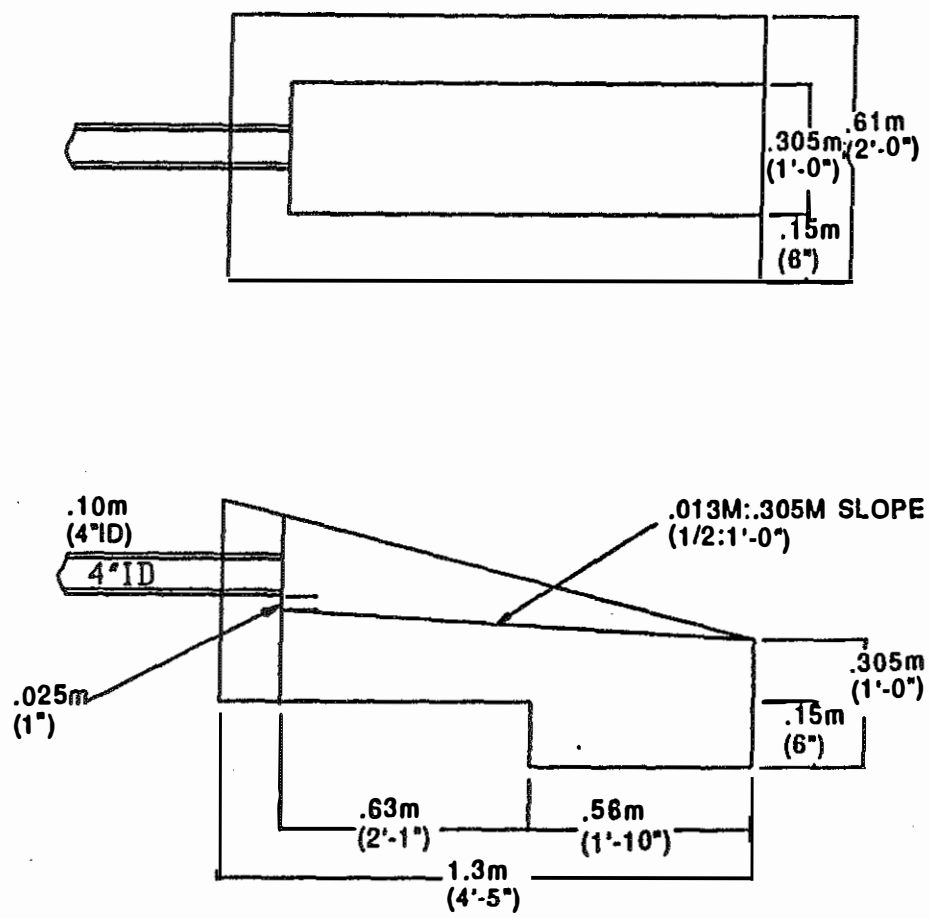

Figure 4. Recommended Headwall Design



Figure 5a. Construction photo showing single wall flexible pipe coming from headwall being attached to double wall outlet pipe. Research indicates that most of the damage occurs in the flexible pipe “pigtail” coming from the headwall.

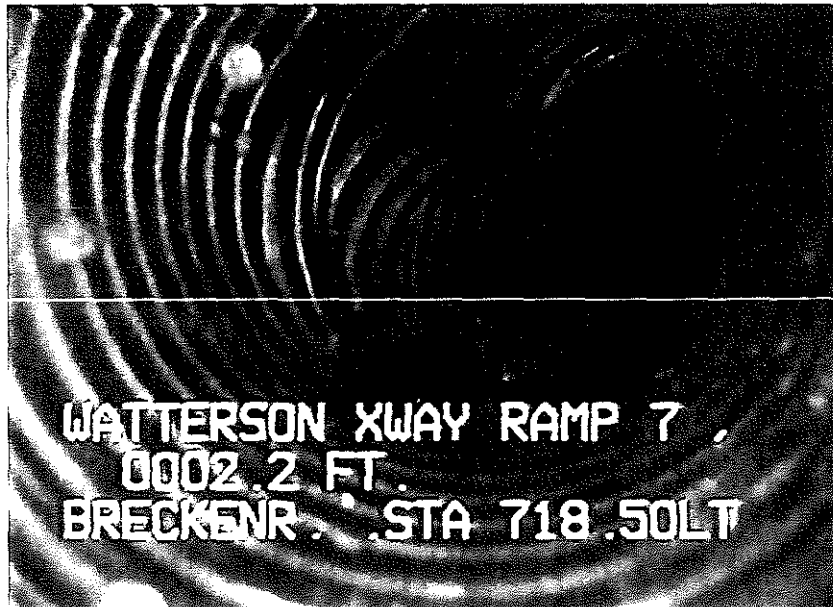

Figure 5b. Partially crushed outlet on backside of outlet.

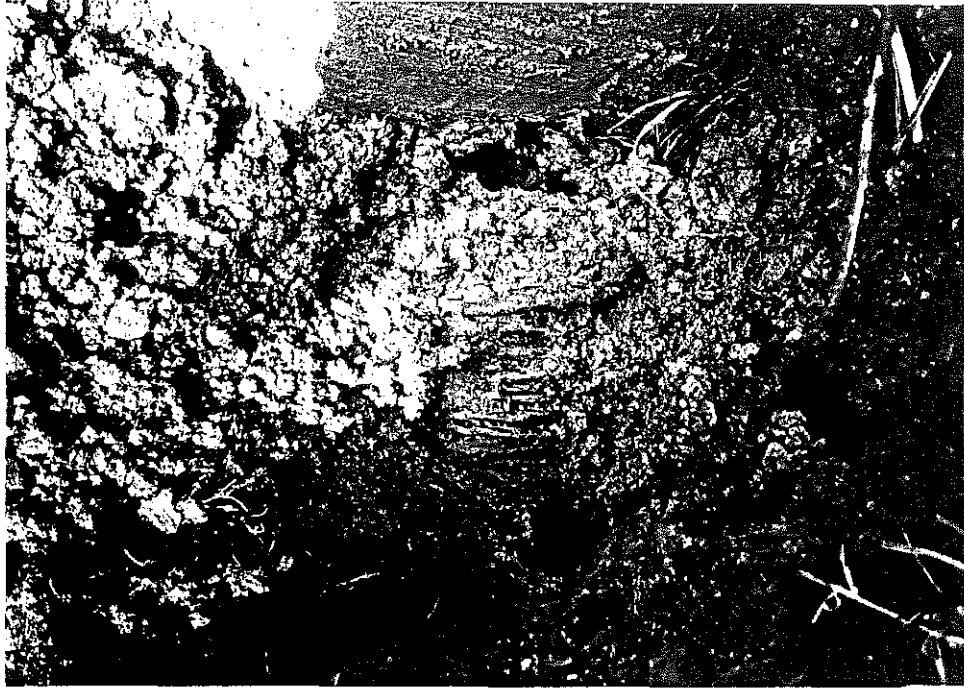

Figure 5c. Rip in single wall pipe, backside of headwall



Figure 6. Outlet pipe being backfilled on Interstate 64.



Figure 7a. Outlet pipes damaged during raising of the shoulder.



Figure 7b. Outlet pipes crushed prior to headwall placement.

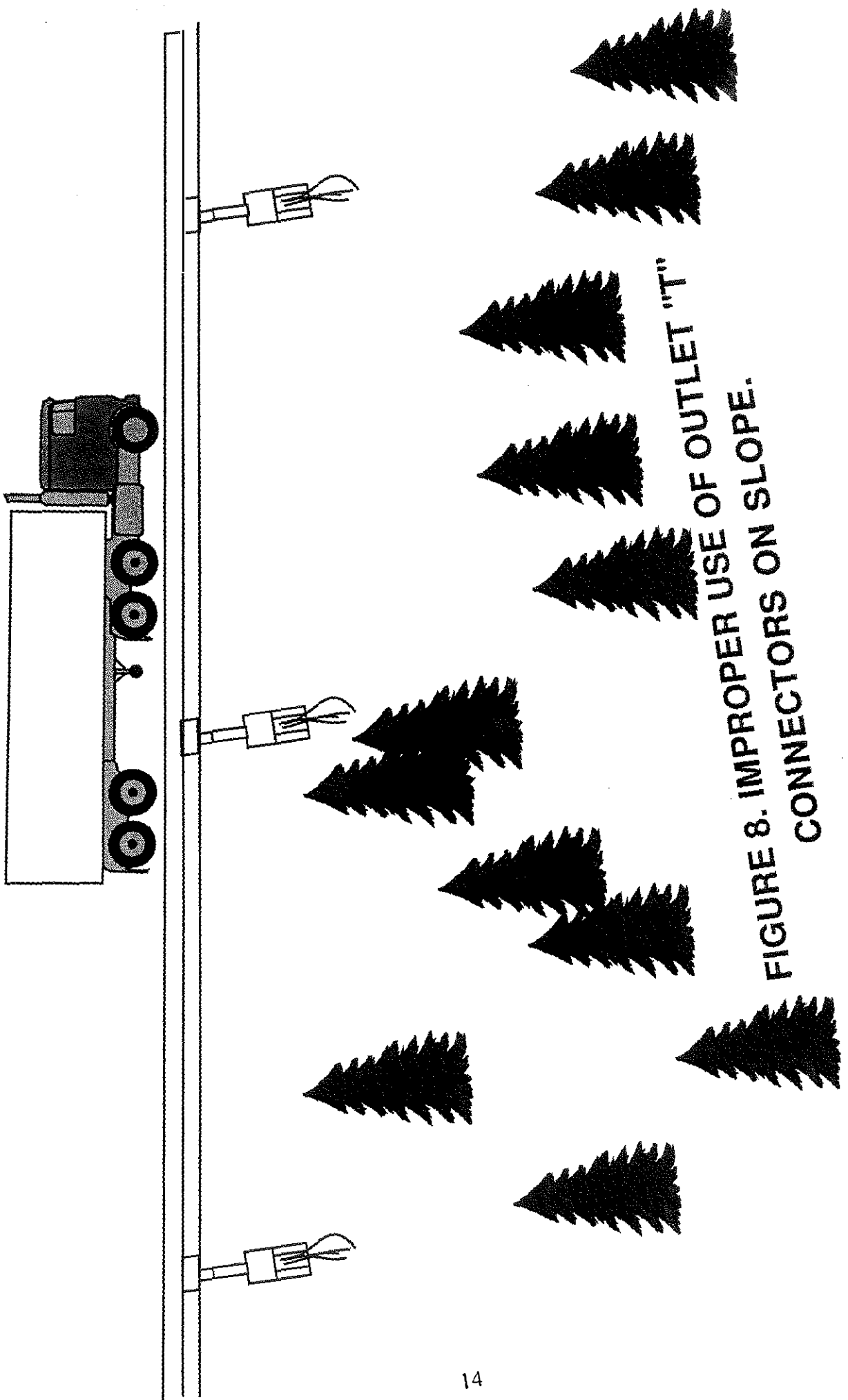

FIGURE 8. IMPROPER USE OF OUTLET "T" CONNECTORS ON SLOPE.

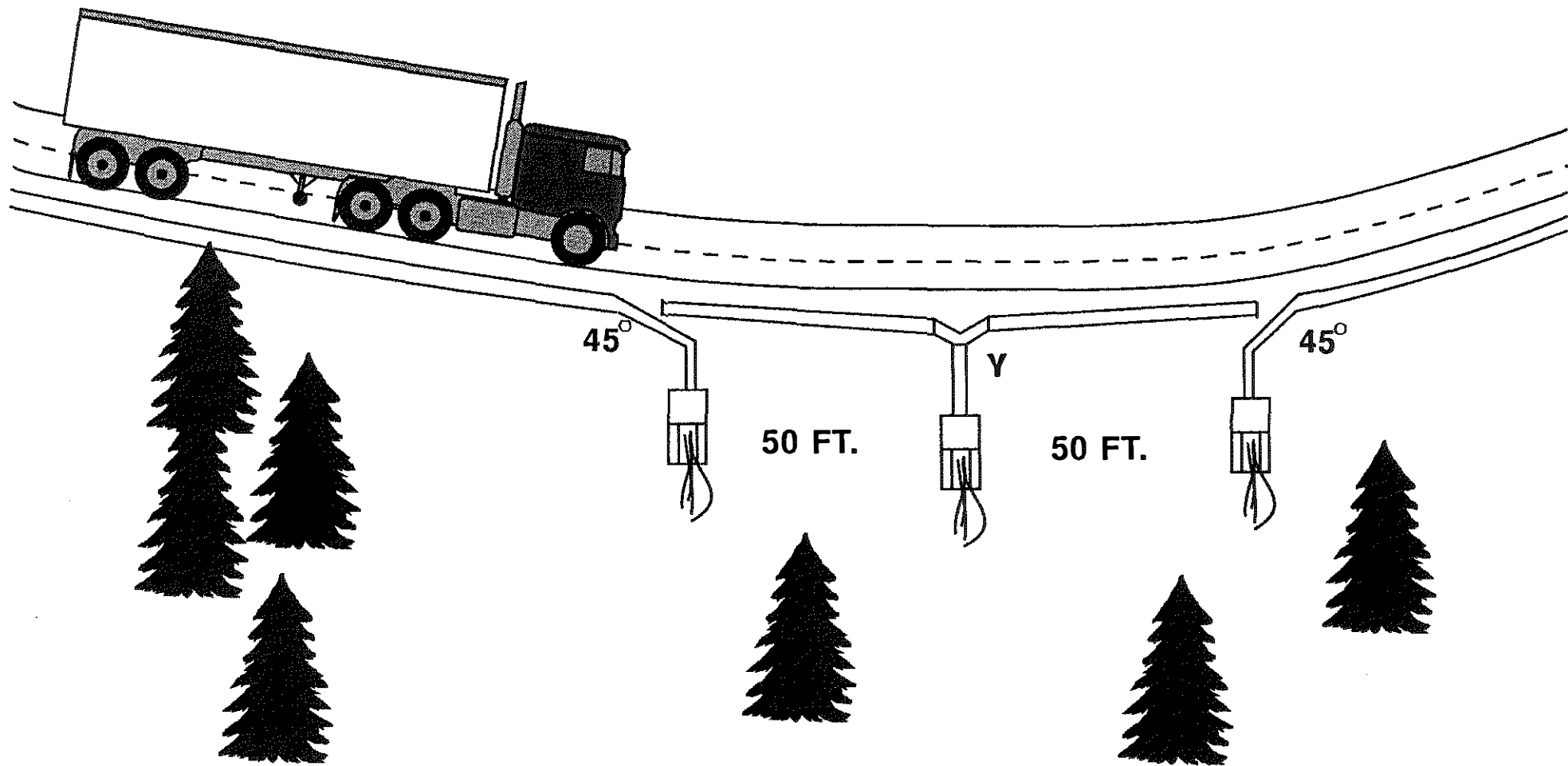

FIGURE 9. RECOMMENDED "Y" CONNECTOR IN PLACE OF "T" CONNECTOR AND RECOMMENDED OUTLET SPACING AT SAGS.

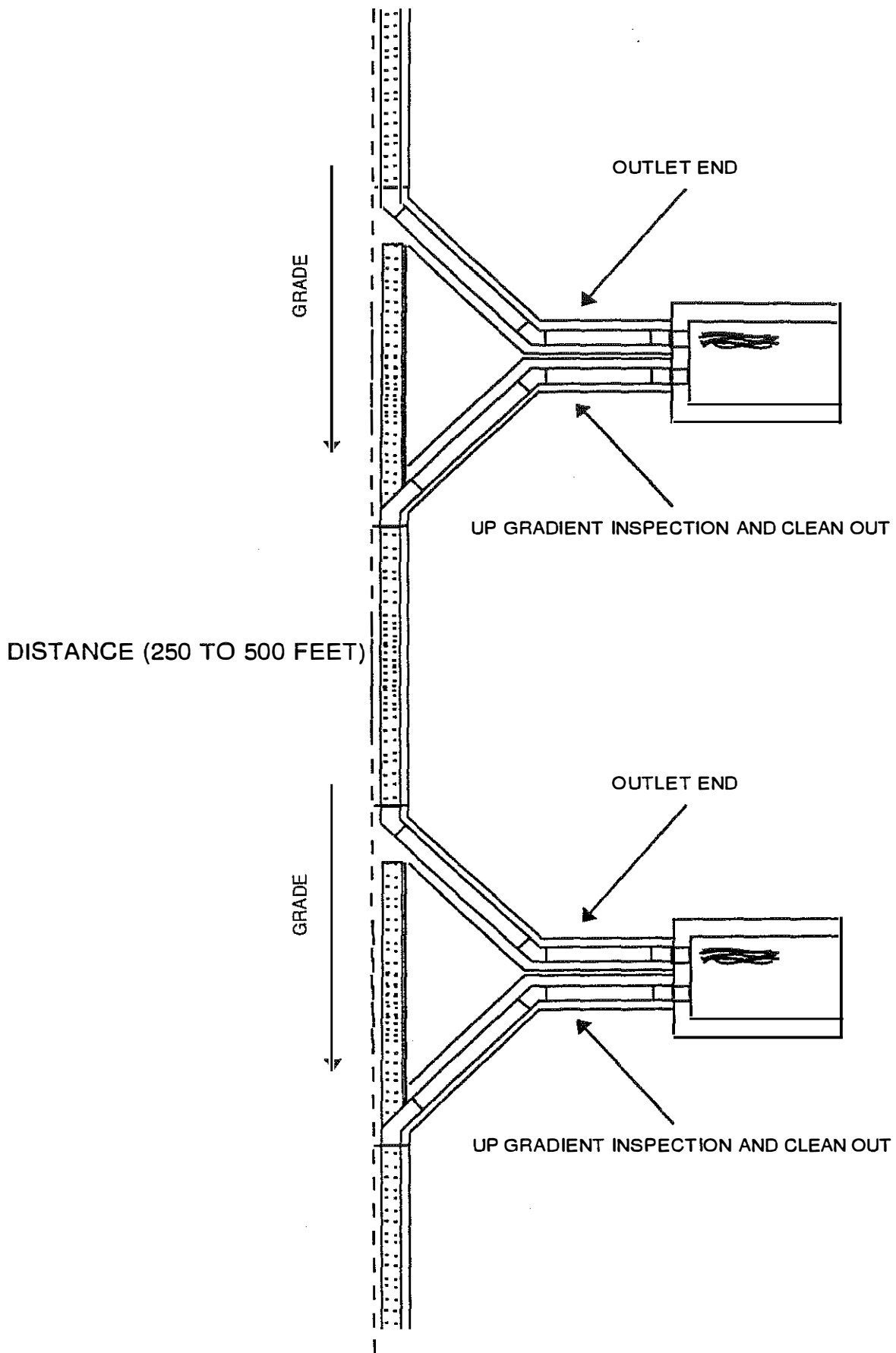

FIGURE 10. LOOP OUTLET SYSTEM DESIGN

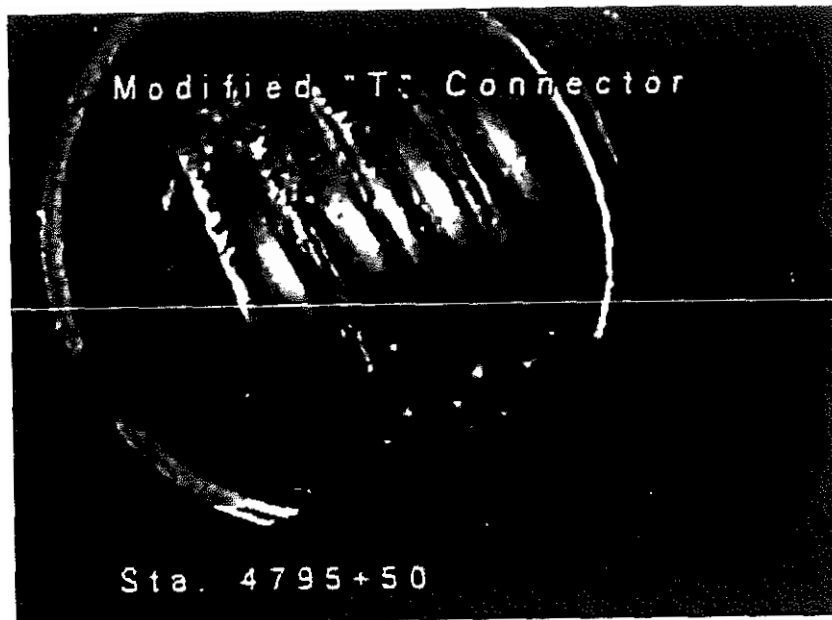

Figure 11. Photo shows modified "T" connector. The "T" connector was modified into a 4-way connector for a sag and cross drain connection. The added pipe was pushed across the outlet pipe portion of the "T".

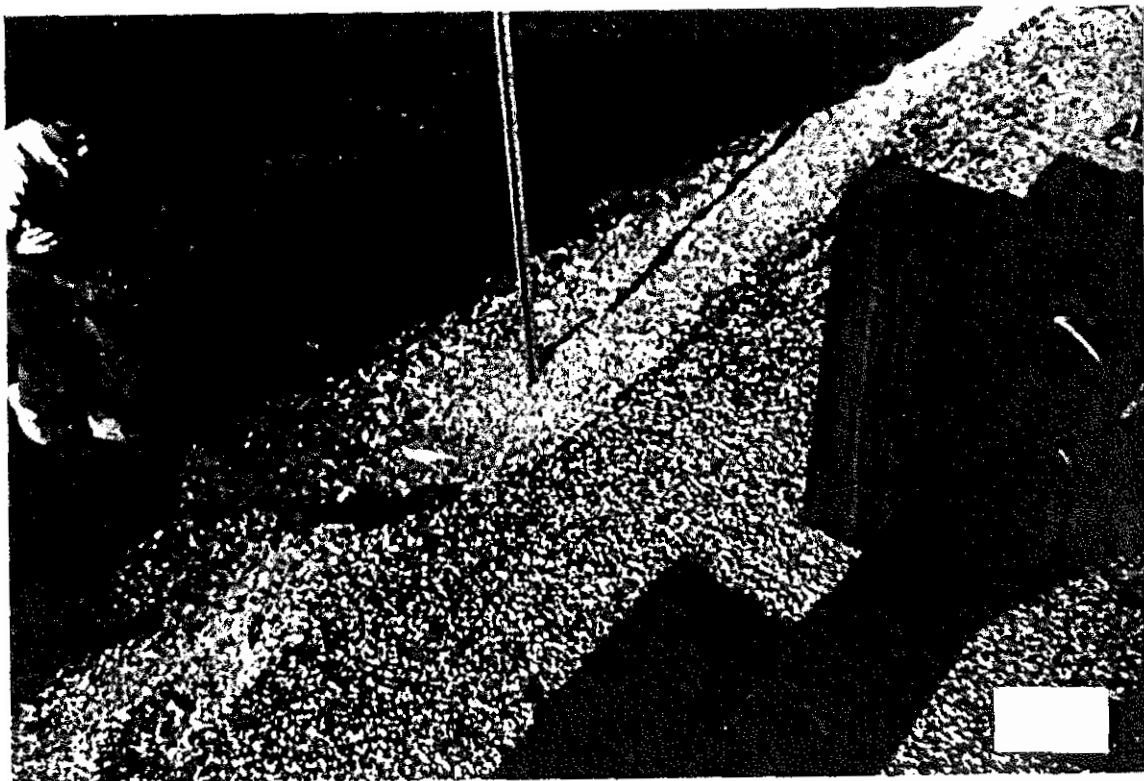

Figure 12. Buried headwall and guardrail post driven through outlet pipe.



Figure 13a. Headwall installed in shallow ditch line.



Figure 14a. Water ponding in ditch line due to soil slide in unstable cut.

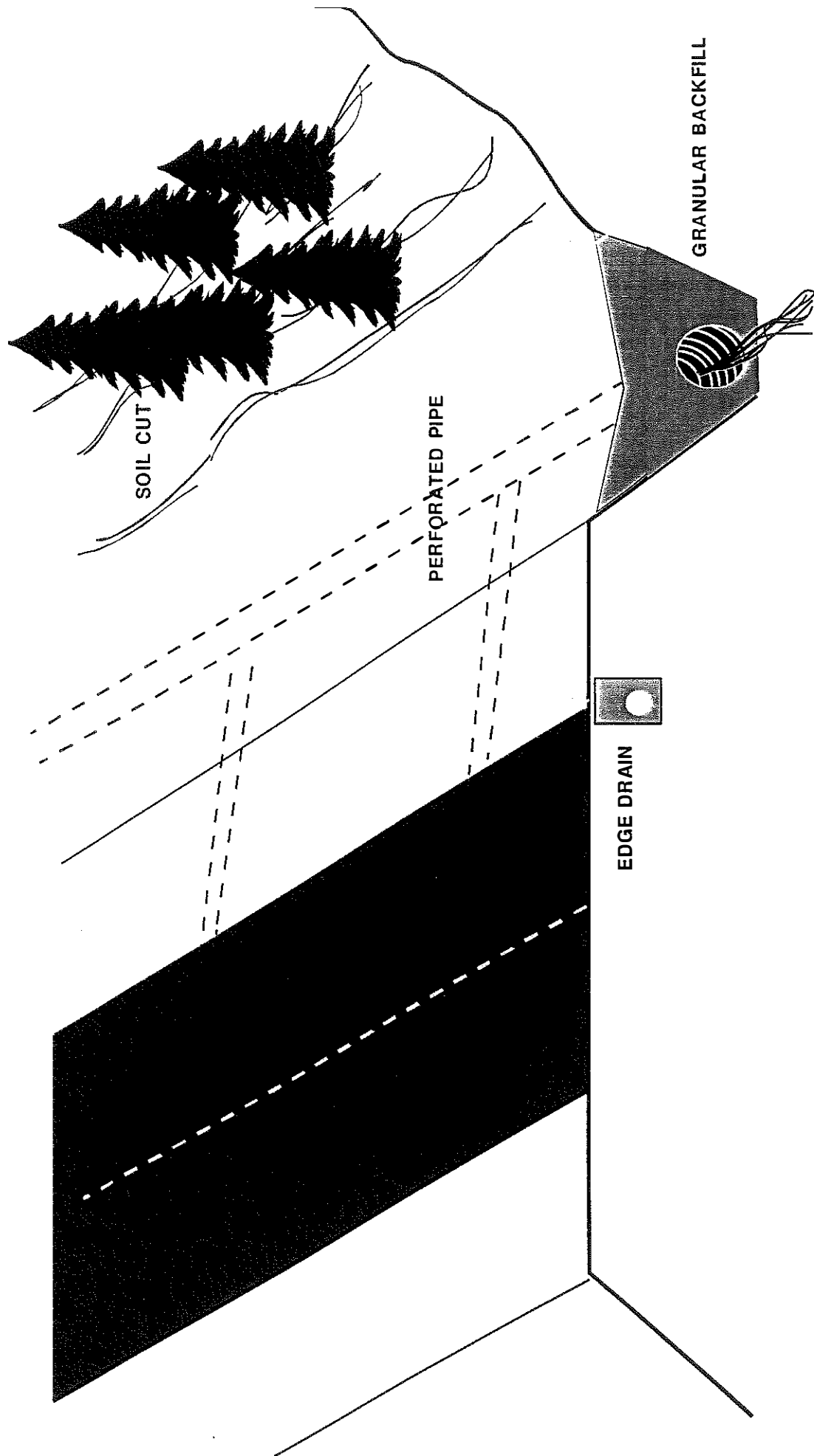

FIGURE 14b. RECOMMENDED DITCH DRAIN

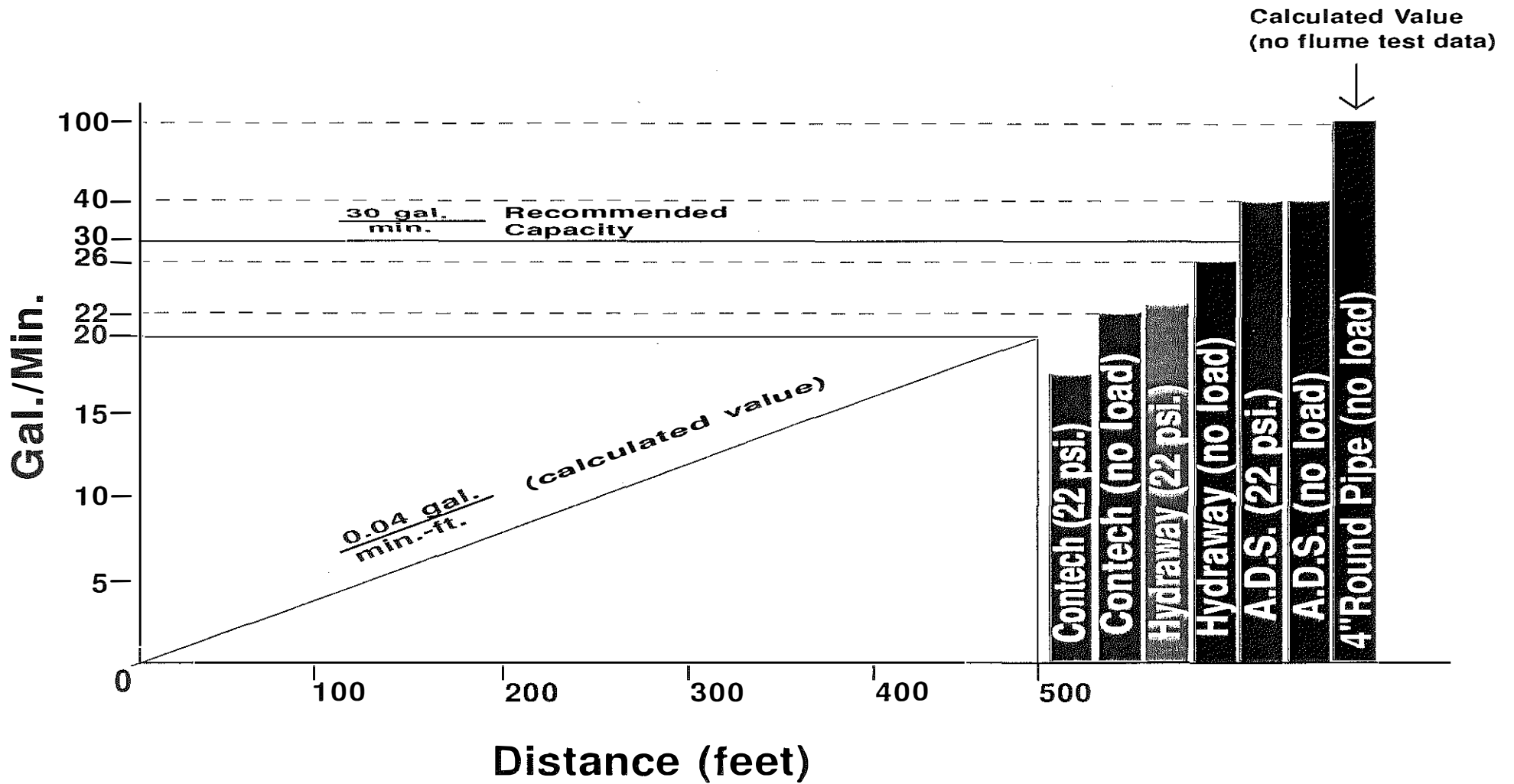

Figure 15. Recommended Edge Drain Flow Capacity

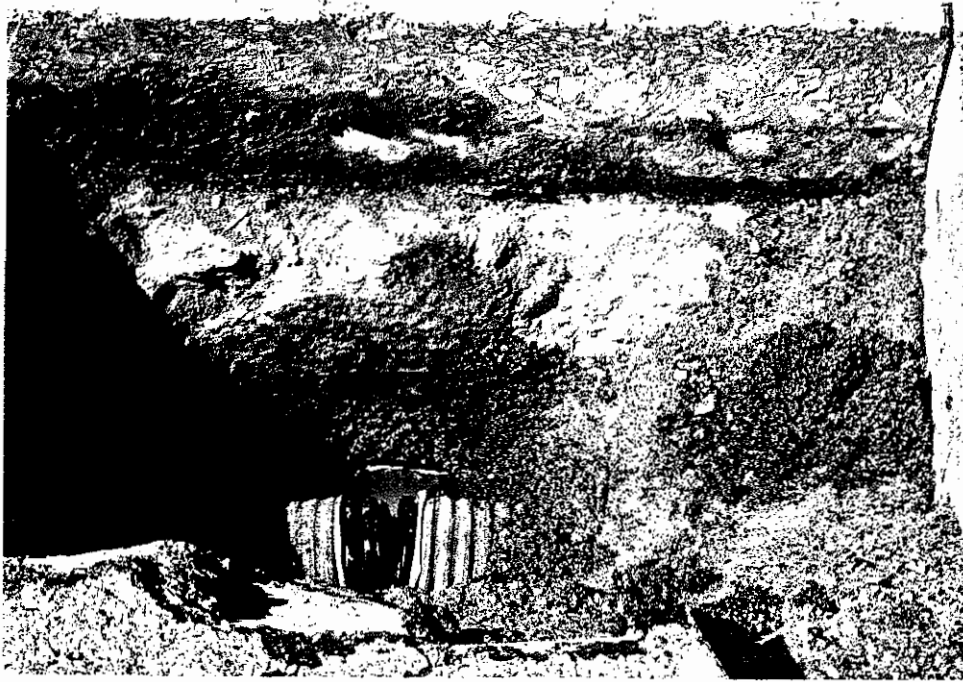

Figure 16. Water standing in sand backfill under pipe.



Figure 17. Settlement in edge drain trench due to traffic being forced onto the shoulder.



Figure 18a. Bridge end drainage being installed.

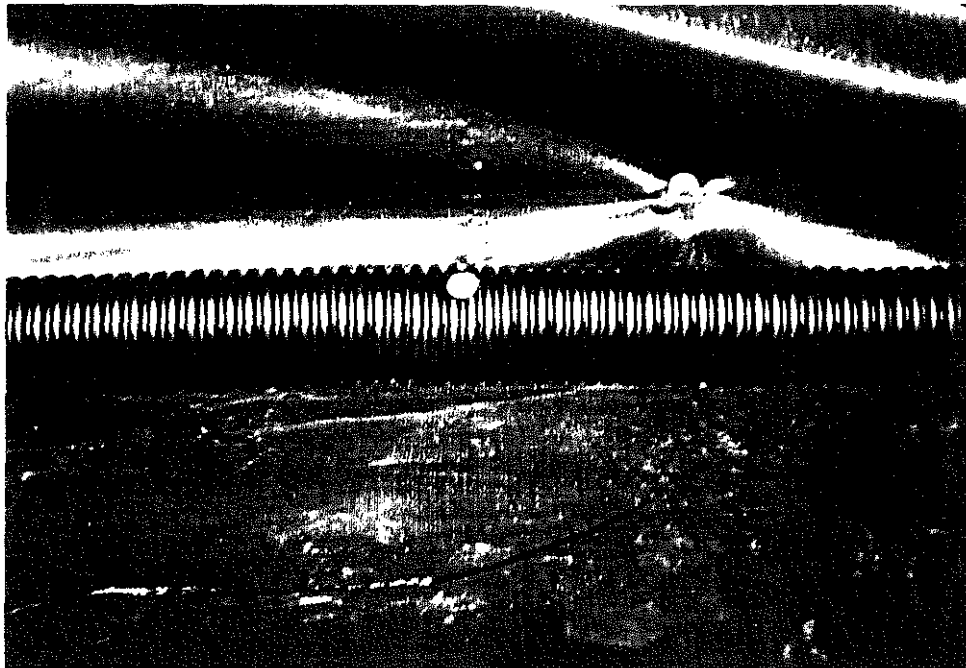

Figure 18b. Spike driven through perforated pipe.

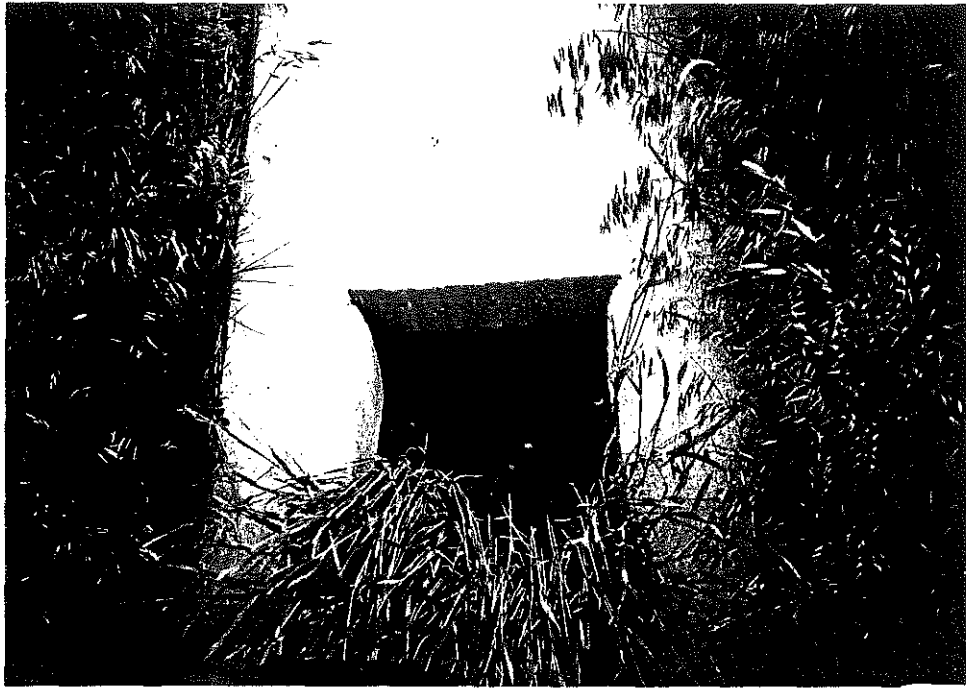

Figure 19a. Headwall trough clogged with grass.

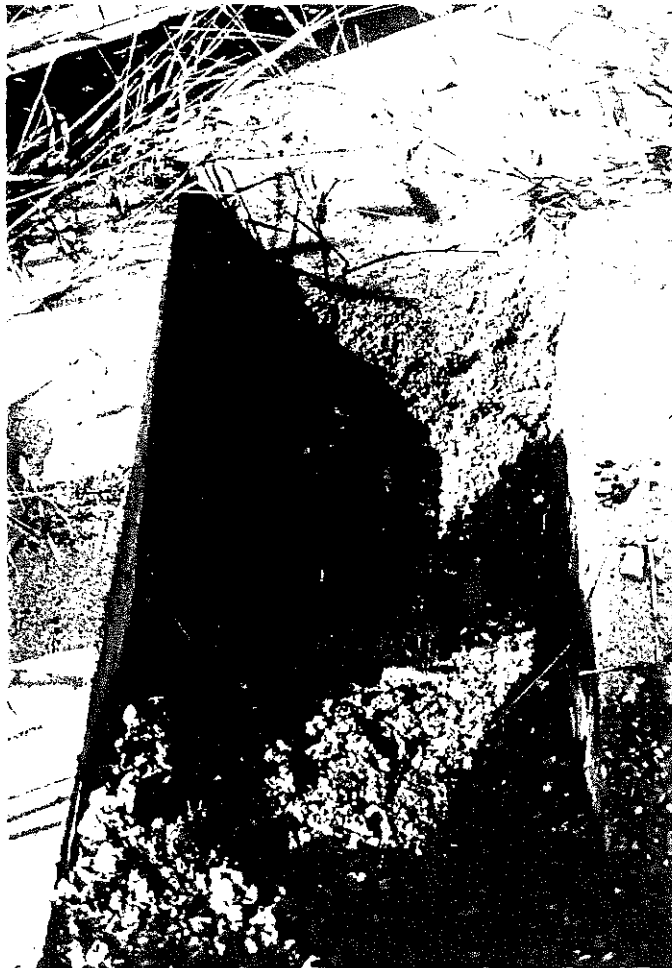

Figure 19b. Clogged rodent screen.



Figure 19c. Partially clogged outlet pipe.



Figure 20a. Signs of water induced failure in asphalt pavement.



Figure 20b. Signs of improper functioning edge drains

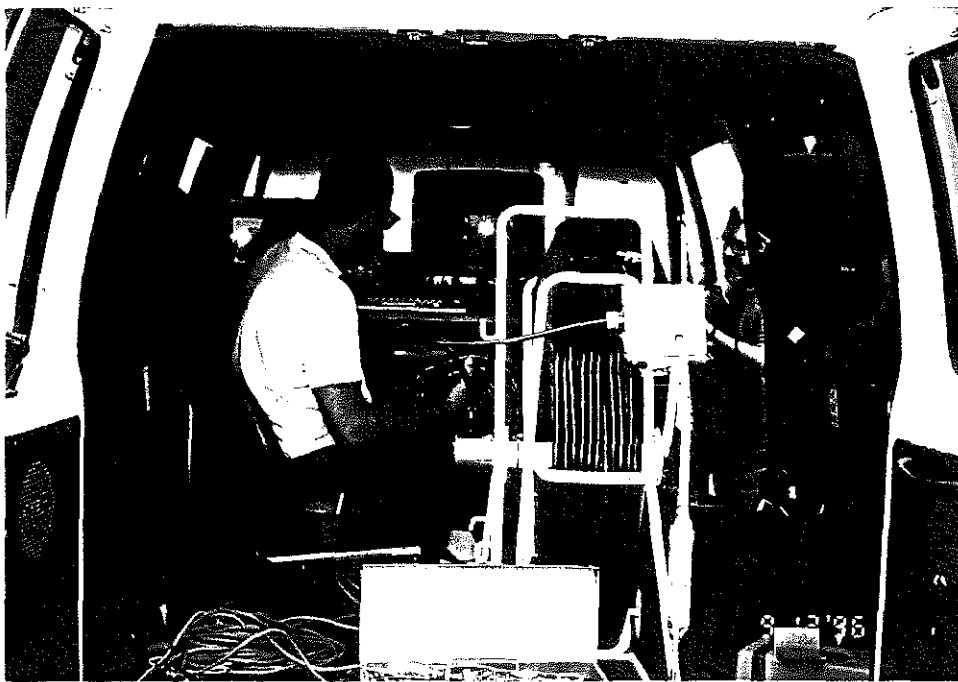

Figure 21a. KTC personnel preparing to inspect outlets on I-275.



Figure 21b. Totally crushed round pipe edge drain on I-264.



Figure 22. Outlet location marked with delineator post.

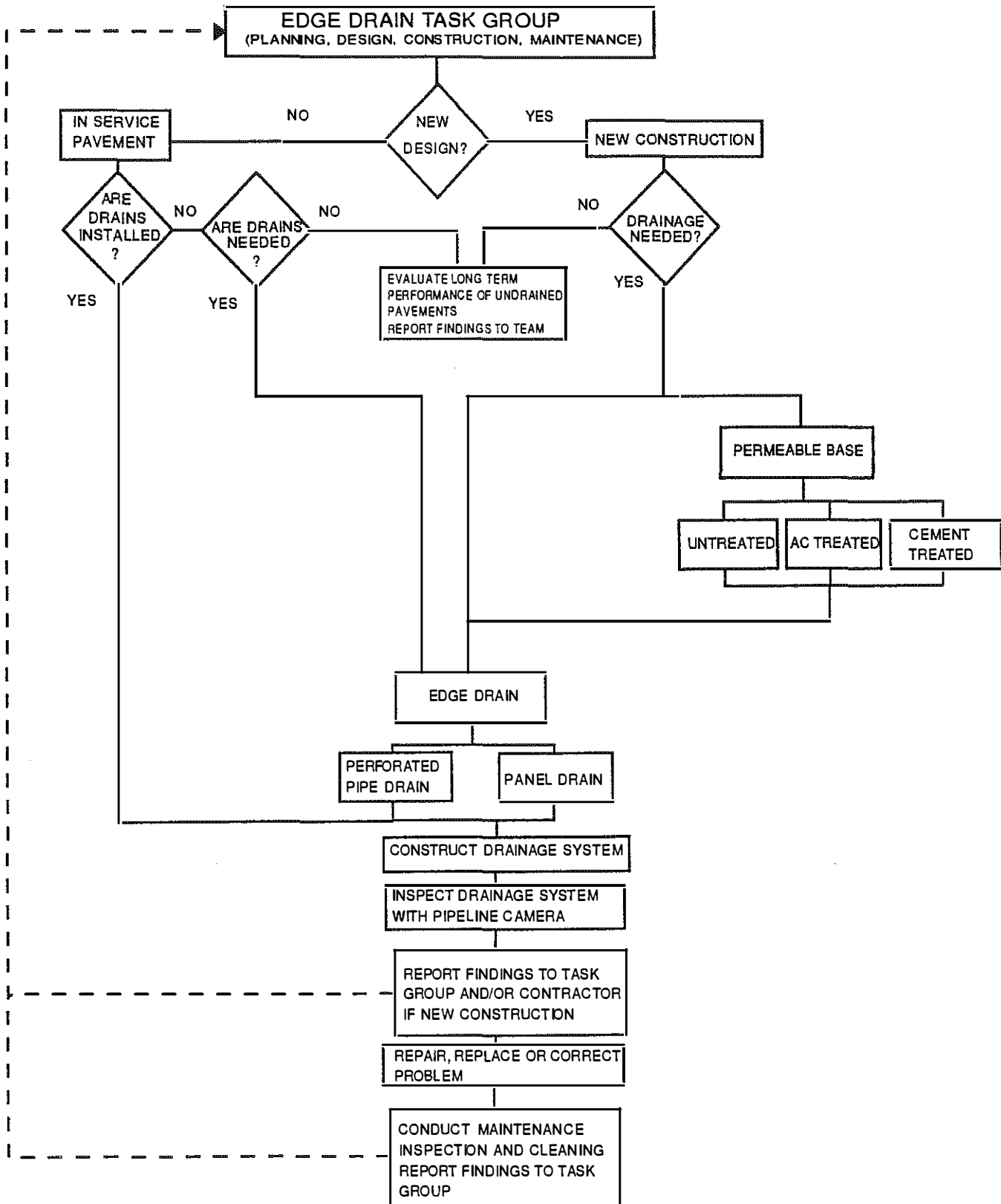

FIGURE 23. RECOMMENDED DRAINAGE TASK GROUP

APPENDIX A
(Data Input and Output from “Pavement Life Cycle Cost Analysis”)

OF PROBLEMS/ALTERNATES = 1

ALTERNATE NO. = 1 Pavement Type = UNBONDED PCC PAVEMENT

DESIGN LANE ESAL'S = 6E+07

ANALYSIS PERIOD = 40 Years

1st YEAR ESALs = 827787.4 Assuming 2% of Traffic Growth

DESIGN SPEED = 60 MPH SUBGRADE CBR = 6

DISTRESS CRITERIA FOR REHABILITATION:

° RUT DEPTH (FOR AC PAVEMENT ONLY) = .6 In.

° INITIAL RI VALUE = 3.6

° RI VALUE = 2.7

PAVEMENT COMPONENT INFORMATION :

LAYER # 1 MATERIAL = PCC PAVEMENT-11 INCH NON-REINF(Type= 3), 11 INCHES

LAYER # 2 MATERIAL = D G A BASE(Type= 2), 6 INCHES

LAYER # 3 MATERIAL = LIME MODIFIED ROADBED(Type= 4), 24 INCHES

of Layers in the System = 3 including subgrade

RI INFORMATIONS (PCC PAVEMENT):

RI DECREASES TO 2.7 AT YEAR = 27

Overlay # 1

Used Overlay Year = 27

Computed Overlay Thickness (AC on PCC=) 3.023212

Computed Overlay Thickness (PCC on PCC=) 1.6

Overlay Thickness used = 3.6

Overlay Thickness used = 3.6 Inches AC, or 8 Inches PCC

Overlay Summary :

No OverLays required = 1

No. At Year, Overlay Thickness = 1 27 3.6/8.0

Remaining Life = 4 Years

Remaining ESALs at the end of Analysis Period = 7633427

** Life-Cycle Cost Analysis **

Interest and Inflation Rates = 6 % and 2 % PA

1a. Initial Cost (Mainline) :

Pavement Width, No. Lane, Section Length = 12 (ft) ; 4 ; 6280 (ft)

Layer# Thick(in) Material Quantity U.Price Item-Cost

1 11 PCC PAVEMENT-11 INCH NON-RENF
28160 SQ YD 26.2168 738236.9

2 6 D G A BASE 8664 TON 10.7622 92069.86

3 24 LIME MODIFIED ROADBED
28160 SQ YD 1.3720 38636.62

Initial Cost (Main-line) 868,932.31

1b. Initial Cost (Shoulders) :

Shoulder Width, No. of Shoulders, Section Length = 18 (ft) ; 2 ; 6280 (ft)

Layer# Thick(in) Material Quantity U.Price Item-Cost

1 11 PCC PAVEMENT-11 INCH NON-RENF
21120 SQ YO 26.2168 563677.7

2 6 D G A BASE
6416 TON 10.7622 69039.62

3 24 LIME MODIFIED ROADBED
21120 SQ YO 1.3720 28976.64

Initial Cost (Shoulders) 651,693.81

2. Maintenance Costs :

Annual Maintenance Present Worth

	Cost (\$/SqYd)	(\$)
Mainlines :	.1	56736.45
Shoulders :	.05	20901.17
<hr/>		
Total Present Worth \$		76,637.63

2a. Rehabilitation/Overlays Costs :

* AC Overlays on PCC Pavement:

#	At Thickness	Quantity	Overlay Area	Present Worth	AC/PC-OVL-U-COST
Year	(in.)	(ton)	(sq ft)	(\$)	
1	27	3.5	9702.	443620	186400 30
<hr/>					
Total \$				186,400.02	

* PCC Overlays on PCC Pavement (UNBONDED):

#	At Thickness	Quantity	Overlay Area	Present Worth	AC/PC-OVL-U-COST
Year	(in.)	(ton)	(sq ft)	(\$)	
1	27	8.	22176.	443620	287081.4 26.2168
<hr/>					
Total \$				287,081.44	

3b. Maintenance of Traffic Costs due to Rehabilitation/Overlays :

Overlay #	Present Worth (\$)
1	62843.16
<hr/>	
TOTAL :	62843.16

4. Miscellaneous Costs :

	Quantity	Unit Price	Installed	Present Worth
	(ft')	(\$/ft')	at Year	(\$)
Edge Drains:	21120	4.50		95,040.00
Guard Rails:	2640	15.00	0	39,600.00
<hr/>				
Total Present Worth \$				134,640.00

5. Delay Cost Due To Rehabilitation :

Duration of Delay = 4380 Hours
 Delay Cost for Car = 10.00 Per Car Per Hour
 Delay Cost for Truck = 30.00 Per Truck Per Hour
 Percent Trucks = 23
 For Overlay # 1 Present Worth Delay Cost is \$ 92,145.7

Total PW Delay Cost is \$92,145.70

8. Effective Costs :

	Present Worth (\$)	
	With AC OVL	With PCC OVL
Initial Cost :	1,520,626.13	1,520,626.13
Maintenance Costs :	76,637.63	76,637.63
Rehabilitation Costs :	186,400.02	287,081.44
Main. of Traffic Costs:	62,843.16	62,843.16
Miscellaneous Costs :	134,640.00	134,640.00
Total Delay Costs :	92,145.70	92,145.70
<hr/>		
Total Effective Cost \$	2,073,292.63	2,173,974.00

6. Life-Cycle Costs Comparison:

Pavement Type	COSTS IN TODAY'S DOLLARS		Remaining Life
	With AC OVL	With PCC OVL	Years/Remaining
Alt. # 1 : AltName	2,073,292.63	2,173,974.00	4/2.94/7.6334

Residual Values in Today's Dollars = 232,104.41

Alt. # 2: 0.00 - -

Residual Values in Today's Dollars = -

Alt. # 3: 0.00 - -

Residual Values in Today's Dollars = -

Note : Remaining life in terms of Years, RI and ESALs(Millions)

RI value is RI at the end of analysis period.

****** END OF OUTPUT ******

OF PROBLEMS/ALTERNATES = 1

ALTERNATE NO. = 1 Pavement Type = UNBONDED PCC PAVEMENT

DESIGN LANE ESAL'S = 6E+07

ANALYSIS PERIOD = 40 Years

1st YEAR ESALS = 827787.4 Assuming 2% of Traffic Growth

DESIGN SPEED = 60 MPH SUBGRADE CBR = 6

DISTRESS CRITERIA FOR REHABILITATION:

* RUT DEPTH (FOR AC PAVEMENT ONLY) = .6 In.

* INITIAL RI VALUE = 3.6

* RI VALUE = 2.7

PAVEMENT COMPONENT INFORMATION :

LAYER # 1 MATERIAL = PCC PAVEMENT-11 INCH NON-REINF(Type = 3), 11 INCHES

LAYER # 2 MATERIAL = D G A BASE(Type = 2), 6 INCHES

LAYER # 3 MATERIAL = LIME MODIFIED ROADBED(Type = 4), 24 INCHES

of Layers in the System = 3 including subgrade

RI INFORMATIONS (PCC PAVEMENT):

RI DECREASES TO 2.7 AT YEAR = 21

Overlay # 1

Used Overlay Year = 21

Computed Overlay Thickness (AC on PCC =) 3.9122

Computed Overlay Thickness (PCC on PCC =) 2

OverLay Thickness used = 4

Overlay Thickness used = 4 Inches AC, or 8 Inches PCC

Overlay # 2

Overlay Year used = 36

Computed Overlay Thickness (AC on PCC =) 3.023212

Computed Overlay Thickness (PCC on PCC =) 1.6

Overlay Thickness used = 3.6 Inches AC, or 8 Inches PCC

Overlay Summary :

No OverLays required = 2

No. At Year, Overlay Thickness = 1 21 4.0/8.0

No. At Year, Overlay Thickness = 2 36 3.6/8.0

Remaining Life = 7 Years

Remaining ESALS at the end of Analysis Period = 1.368829E+07

** Life-Cycle Cost Analysis **

Interest and Inflation Rates = 6 % and 2 % PA

1a. Initial Cost (Mainline) :

Pavement Width, No. Lane, Section Length = 12 (ft) ; 4 ; 6280 (ft)

Layer# Thickness Material Quantity U.Price Item-Cost

1 11 PCC PAVEMENT-11 INCH NON-REINF
28160 SQ YD 26.2168 738236.9

2 6 D G A BASE 8663.6 TON 10.7622 92066.66

3 24 LIME MODIFIED ROADBED
28160 SQ YD 1.3720 38636.62

Initial Cost (Main-line) 868,928.00

1b. Initial Cost (Shoulders) :

Shoulder Width, No. of Shoulders, Section Length = 18 (ft) ; 2 ; 6280 (ft)

Layer# Thickness Material Quantity U.Price Item-Cost

1 11 PCC PAVEMENT-11 INCH NON-REINF
21120 SQ YD 26.2168 663677.7

2 6 D G A BASE
6416.2 TON 10.7622 69041.67

3 24 LIME MODIFIED ROADBED

Initial Cost (Shoulders) 661,696.00

2. Maintenance Costs :

	Annual Maintenance Cost (\$/SqYd)	Present Worth (\$)
Mainlines :	0.10	66736.46
Shoulders :	.06	20901.17
<hr/>		
Total Present Worth \$		76,637.63

3a. Rehabilitation/Overlays Costs :

* AC Overlays on PCC Pavement:

#	At	Thickness	Quantity	Overlay	Area	Present	Worth	AC/PC-OVL-U-COST
Year	(in.)	(ton)	(sq ft)			(\$)		
1	21	4.	10348.8	443620	244370.6	30		
2	36	3.6	9056.2	443620	126234	30		
<hr/>								
Total \$						370,604.66		

* PCC Overlays on PCC Pavement (UNBONDED):

#	At	Thickness	Quantity	Overlay	Area	Present	Worth	AC/PC-OVL-U-COST
Year	(in.)	(ton)	(sq ft)			(\$)		
1	21	8.	49280.	443620	676064.2	26.2168		
2	36	8.	49280.	443620	374839.2	26.2168		
<hr/>								
Total \$						1,049,903.38		

3b. Maintenance of Traffic Costs due to Rehabilitation/Overlays :

Overlay #	Present Worth (\$)
1	79516.66
2	44162.77
<hr/>	
TOTAL :	123669.4

4. Miscellaneous Costs :

	Quantity (ft')	Unit Price (\$/ft')	Installed at Year	Present Worth (\$)
Edge Drains:	0	4.6	0	0.00
Guard Rails:	2640	16.00	0	39,600.00
<hr/>				
Total Present Worth \$				39,600.00

5. Delay Cost Due To Rehabilitation :

Duration of Delay = 4380 Hours
 Delay Cost for Car = 10.00 Per Car Per Hour
 Delay Cost for Truck = 30.00 Per Truck Per Hour
 Percent Trucks = 23
 For Overlay # 1 Present Worth Delay Cost is \$ 98820.94
 For Overlay # 2 Present Worth Delay Cost is \$ 83227.49

 Total PW Delay Cost is \$182,048.44

6. Effective Costs :

	Present Worth (\$)	
	With AC OVL	With PCC OVL
Initial Cost	: 1,620,624.00	1,620,624.00
Maintenance Costs	: 76,637.63	76,637.63
Rehabilitation Costs	: 370,604.66	1,049,903.38
Main. of Traffic Costs:	123,669.42	123,669.42

Miscellaneous Costs : 39,600.00 39,600.00
 Total Delay Costs : 182,048.44 182,048.44

Total Effective Cost \$ 2,313,184.26 2,992,482.76

6. Life-Cycle Costs Comparison:

Pavement Type	COSTS IN TODAY'S DOLLARS		Remaining Life Years/RI/Mil.ESALs
	With AC OVL	With PCC OVL	
Alt. # 1 :AltName	2,313,184.26	2,992,482.76	7/3.26/13.6883
Residual Values in Today's Dollars = 238,814.27			
Alt. # 2 :	0.00	-	-
Residual Values in Today's Dollars = -			
Alt. # 3 :	0.00	-	-
Residual Values in Today's Dollars = -			

Note : Remaining life in terms of Years, RI and ESALs(Millions)

RI value is RI at the end of analysis period.

***** END OF OUTPUT *****

APPENDIX B
(Proposed Specification for Pavement Edge Drain Installation in Kentucky)

**PROPOSED SPECIFICATION
FOR PAVEMENT EDGE DRAIN
INSTALLATION IN KENTUCKY**

by

L. John Fleckenstein
Senior Principal Research Investigator

and

David L. Allen
Chief Research Engineer

Kentucky Transportation Center
College of Engineering
University of Kentucky
Lexington, Kentucky

March 14, 1997

**SPECIAL PROVISION FOR PREFABRICATED
PERFORATED ROUND PIPE EDGE DRAIN**

SPECIAL PROVISION FOR PREFABRICATED PERFORATED ROUND PIPE EDGE DRAIN

I. DESCRIPTION

This Special Provision shall apply when indicated on the plans or in the proposal. Section references herein are to the Department's current Standard Specifications for Road and Bridge Construction. This work shall consist of furnishing and installing a prefabricated perforated round pipe drain in accordance with this Special Provision and as directed by the Engineer.

II. MATERIALS

A. General. The core of the prefabricated round pipe edge drain shall comply with AASHTO M 252. The pipe shall have a minimum I.D. of 100 mm. A geotextile shall be used to reduce infiltration of fines into the pipe drain, either a fabric wrapped trench or a sock wrapped pipe (Drawing No. 1).

B. Acceptance. The perforated pipe shall comply with AASHTO M 252.

III. CONSTRUCTION REQUIREMENTS

A. Inspection, Handling, and Storage. The prefabricated perforated pipe drain, and fittings shall be inspected upon receipt at the job site. The shipment shall be inspected for conformance to product specifications, contract documents, and checked for damage. Damaged or deformed material shall be removed from the project. The material shall be stored to prevent damage. The material shall be stored away from exposure to ultraviolet light and direct sunlight.

B. Installation of Pipe Drain. The prefabricated perforated pipe drain shall be installed in a 300- mm wide trench (Drawing No. 2). A clean neat edge shall be cut in the existing bituminous pavement before excavating the trench. The pipe shall be placed on the bottom of the trench. The trench shall be cut to a depth 102 mm below the base of the existing DGA. The trench shall be backfilled with an open graded aggregate (specified by the engineer), and compacted in three lifts.

Splices, when required, shall be made prior to placing the pipe drain in the trench. Splices shall be made using splice kits furnished by the manufacturer and in accordance with the manufacturer's written instructions. Any equipment required for the splicing shall be furnished by the Contractor. Assembly of joints shall not damage the pipe and shall not impede the open flow area of the pipe, and retain the position of the pipe drain as designated on the plans or as directed by the Engineer. The joints shall prevent infiltration of the backfill or any fine material.

The final elevation of the edge drain back fill shall be no less than 100 mm below the surface of the top of the trench. When this requirement is not met, the Contractor shall add additional back fill. The remainder of the trench shall be backfilled with a Class I bituminous concrete surface.

C. Installation of Edge Drain Outlets. Outlets shall be constructed at the locations shown on the plans or as directed by the Engineer. Outlet fittings to transition from the prefabricated edge panel drain to a non-perforated 100-mm smooth lined pipe shall be furnished by the manufacturer, and shall be installed in accordance with the manufacturer's written instructions. The connection of the pipe drain to an outlet pipe shall be made with a 45-degree elbow and bending the pipe drain shall not be permitted. At the sags of vertical curves, the pipe drain may be connected to the outlet pipe with a "Y" connector. An additional outlet shall be placed 50 feet on each side of the headwall in the center of the sag (Drawing No. 3). The connection from the pipe drain to the outlet pipe shall be securely connected without impeding the flow.

The outlet pipe leading to the headwall from the pipe drain shall be one of the following alternates:

- 1) Corrugated Polyethylene Pipe Type S, meeting the requirements of AASHTO M 252. (Landfill Grade, Pipe Stiffness 71-72)
- 2) PVC pipe meeting the requirements of either ASTM D 1785 for schedule 40 or ASTM D 2241 for SDR 17.
- 3) Corrugated steel or corrugated aluminum pipe meeting the requirements specified in Section 705.
- 4) Ribbed PVC pipe meeting the requirements of ASTM F 794 Series 46.
- 5) Corrugated PVC pipe meeting the requirements of ASTM F 949.

The outlet pipe which is chosen by the contractor from the five alternates shall also be precast into the headwall to allow for a smooth transition from the outlet to the headwall. Headwalls not utilizing one of the five alternates are not acceptable and will be removed from the site at the contractor's expense.

All outlet pipe shall be 100-mm diameter, unless otherwise noted on the plans or in the proposal. Care shall be exercised to prevent sags, tears, or compression in the outlet pipes. Trenches excavated for outlet pipes shall be back filled with dense-graded aggregate.

The outlet pipe shall be installed at a desired 4 percent grade, or 3 percent minimum to insure positive outflow.

All material removed from the trench which is not used for other purposes required by the contract or as specified or permitted by the Engineer, shall be removed from the project site at no additional cost to the Department.

For those situations where guardrail will be attached to a structure, such as a bridge end or a pier, the placement of the outlet pipe shall be adjusted such that the guardrail posts will not be driven within a horizontal distance of no less than 300 mm of the outlet pipe for prefabricated perforated pipe drains.

Where guardrail is not attached to a structure, the placement of the guardrail posts and/ or the outlet pipe shall be adjusted such that the guardrail posts are not driven within a horizontal distance of no less than 300 mm of the outlet pipe for prefabricated perforated pipe drains.

The Contractor shall mark the location of the outlet pipe for prefabricated perforated pipe drains with paint or by other means as approved by the Engineer.

Damage to any outlet pipe by guardrail installation shall be acceptably repaired or the damaged outlet pipe shall removed and replaced by the Contractor, at no additional cost to the Department.

The outlet pipe headwall shall conform to Standard Drawing No. RDP-010-04. The pipe used in the headwall shall conform to the outlet pipe. The site for the headwall shall be undercut by 200 mm and backfilled with DGA. The DGA shall be mechanically compacted to achieve maximum density. The prepared surface for the headwall shall be constructed so that after placement of the headwall the headwall slopes 12 mm (0.5 inches) per 300 mm (linear foot) for positive outlet flow from the headwall. When settlement occurs in the headwall prior to final inspection, the contractor shall reset the headwall at his expense. The headwall shall also have a minimum of 150 to 300 mm of freeboard from the base of the headwall trough to the bottom of the ditch.

In addition to the requirements of Standard Drawing No. RDP-010-04, Crushed Aggregate Size No. 2 conforming to Section 805 of the Kentucky Standard Specifications for Road and Bridge Construction shall be used at all pavement subsurface drainage pipe headwall outlets. The Crushed Aggregate Size No. 2 shall be placed a minimum depth of 100 mm. The stone shall be placed a lateral distance of 0.6 m from the sides and the top of the headwall and for a distance of 1.2 m from the toe of the headwall.

Dense Graded Aggregate (DGA) removed to allow placement of the Crushed Aggregate Size No. 2 shall be used to dress existing shoulders where DGA is exposed. Other material removed to allow placement of the Crushed Aggregate Size No. 2 shall be disposed of as directed by the Engineer. No direct payment will be allowed for disposal of removed material.

D. Inspection of Prefabricated Perforated Pipe Drain Mainline and Outlet. The final product will be inspected using a mini camera. The mainline and the outlet pipe shall not be deflected greater than 5 percent, and shall be free of tears, debris, and sags.

The geotextile fabric surrounding the drain shall be free of rips or punctures. If the mainline or the outlet pipe is not properly installed, the mainline or the outlet shall be removed and replaced at the Contractor's expense.

E. Adjustment of Quantities. The Engineer reserves the right to make increases or decreases in the quantity of prefabricated perforated pipe drain constructed as may be required, in accordance with Section 104.02.

IV. METHOD OF MEASUREMENT AND BASIS OF PAYMENT

The prefabricated perforated pipe drain will be measured in linear meters complete and

accepted in the final work. Payment for the accepted quantity at the contract unit price for perforated pipe drain will be full compensation for perforated pipe drain trench excavation; backfill, including dried natural sand and water; furnishing and installing all drain materials, including splices and fittings; and all equipment, labor, and incidentals necessary to complete the work.

Outlet pipe, outlet pipe headwall, bituminous mixtures, and other items required by the contract will be measured and paid for as specified elsewhere in the contract.

The contract unit price for Crushed Aggregate Size No. 2 will be full compensation for all materials, labor, and other incidentals necessary to place Crushed Aggregate Size No. 2 for control of vegetation and erosion at pipe drain outlet headwalls.

TYPICAL DETAIL FOR INSTALLATION OF PREFABRICATED PERFORATED PIPE DRAINS

PERFORATED PIPE AND FABRIC WRAPPED TRENCH

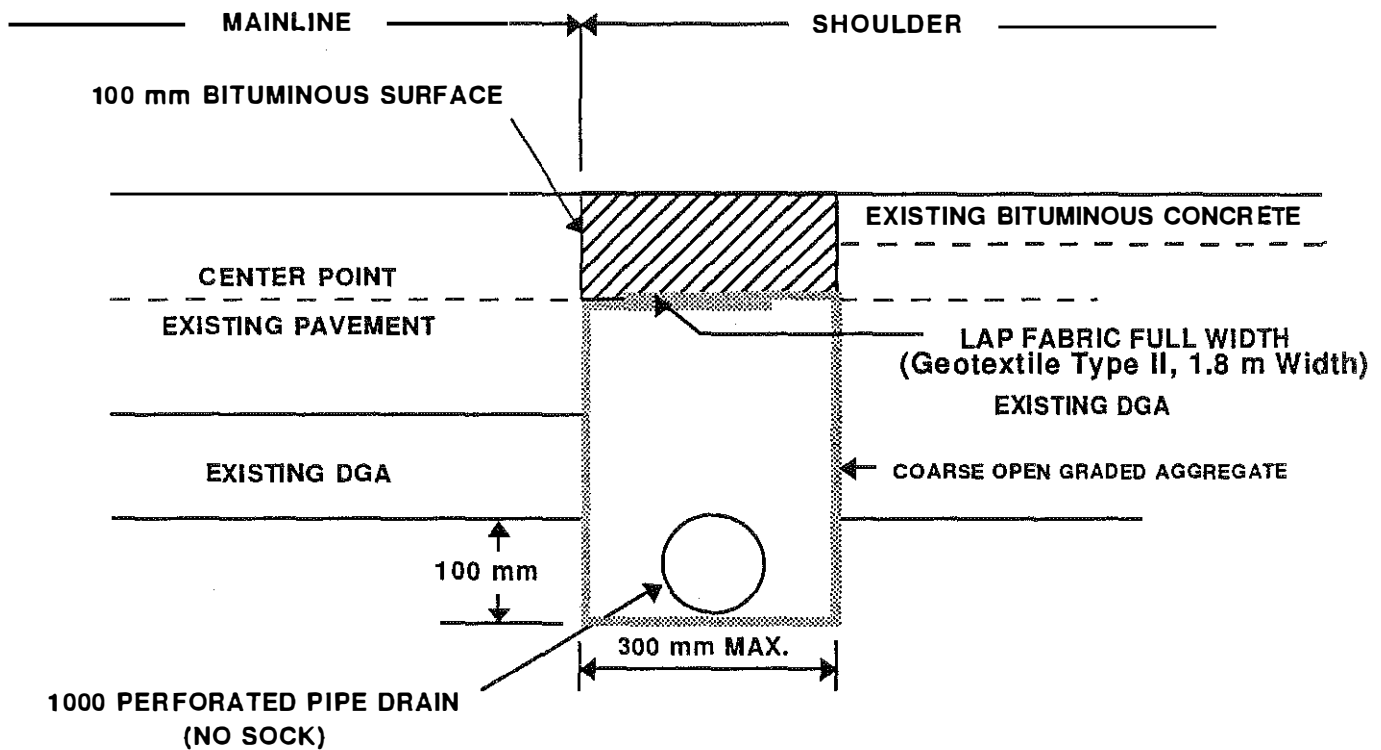

PERFORATED PIPE (SOCK WRAPPED)

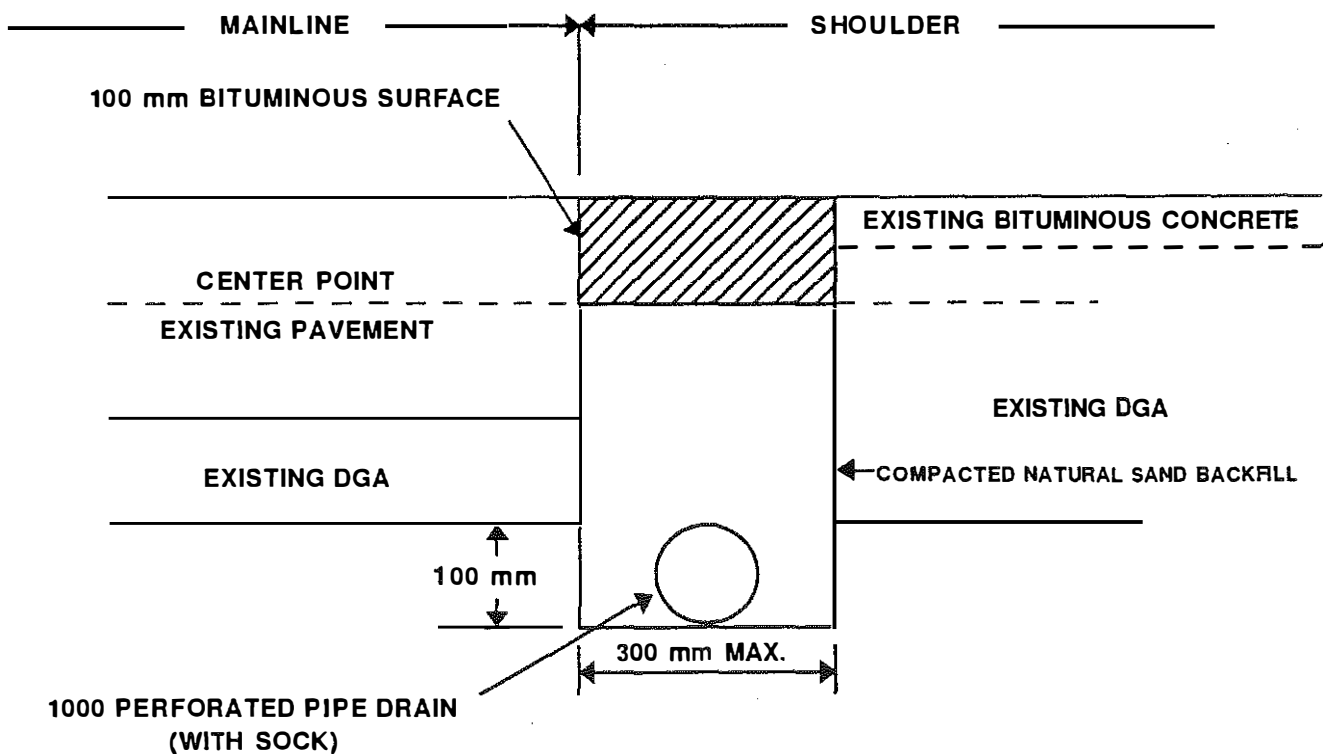

DRAWING NO. 1

LONGITUDINAL PAVEMENT EDGE DRAIN (PERFORATED PIPE)

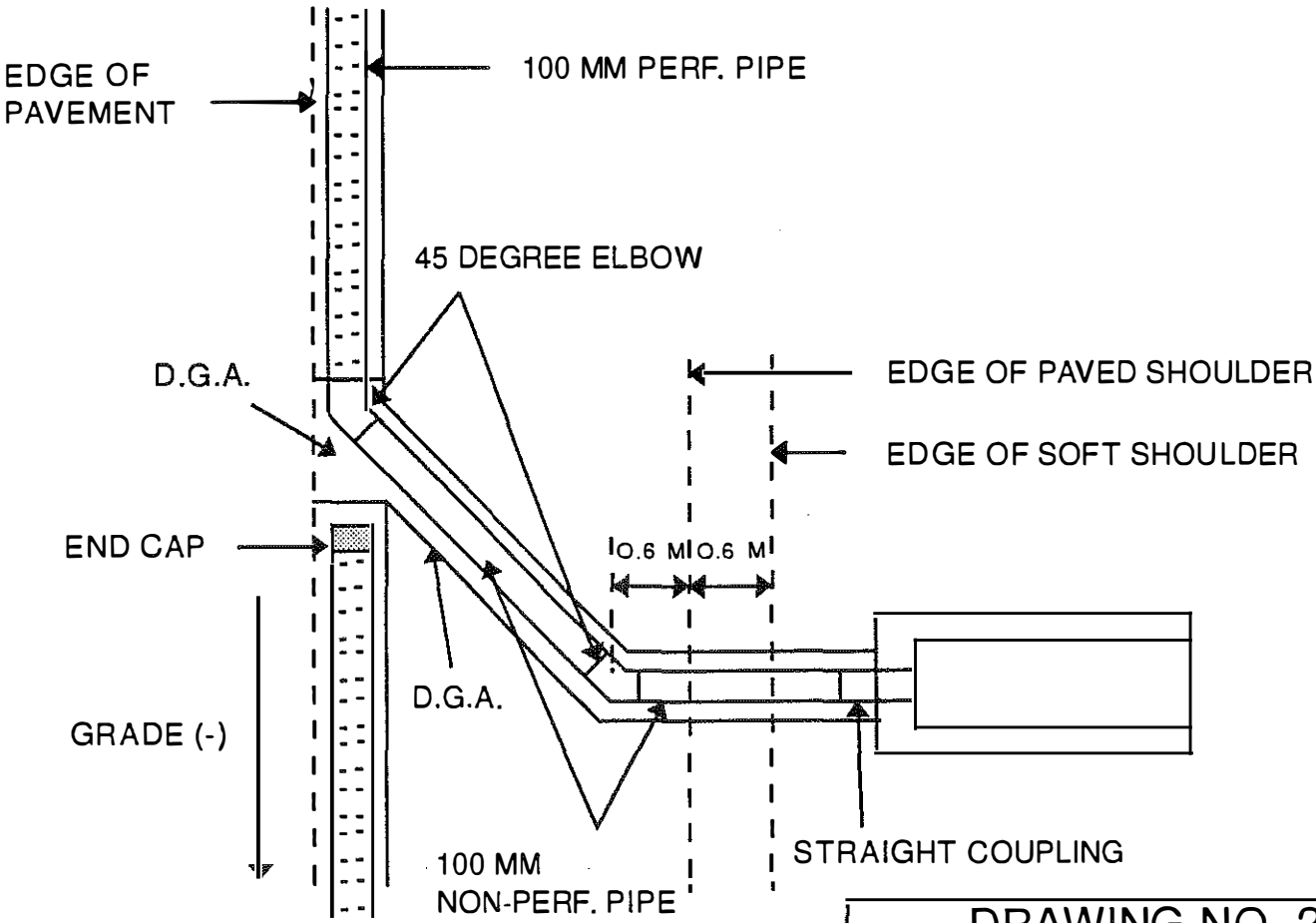
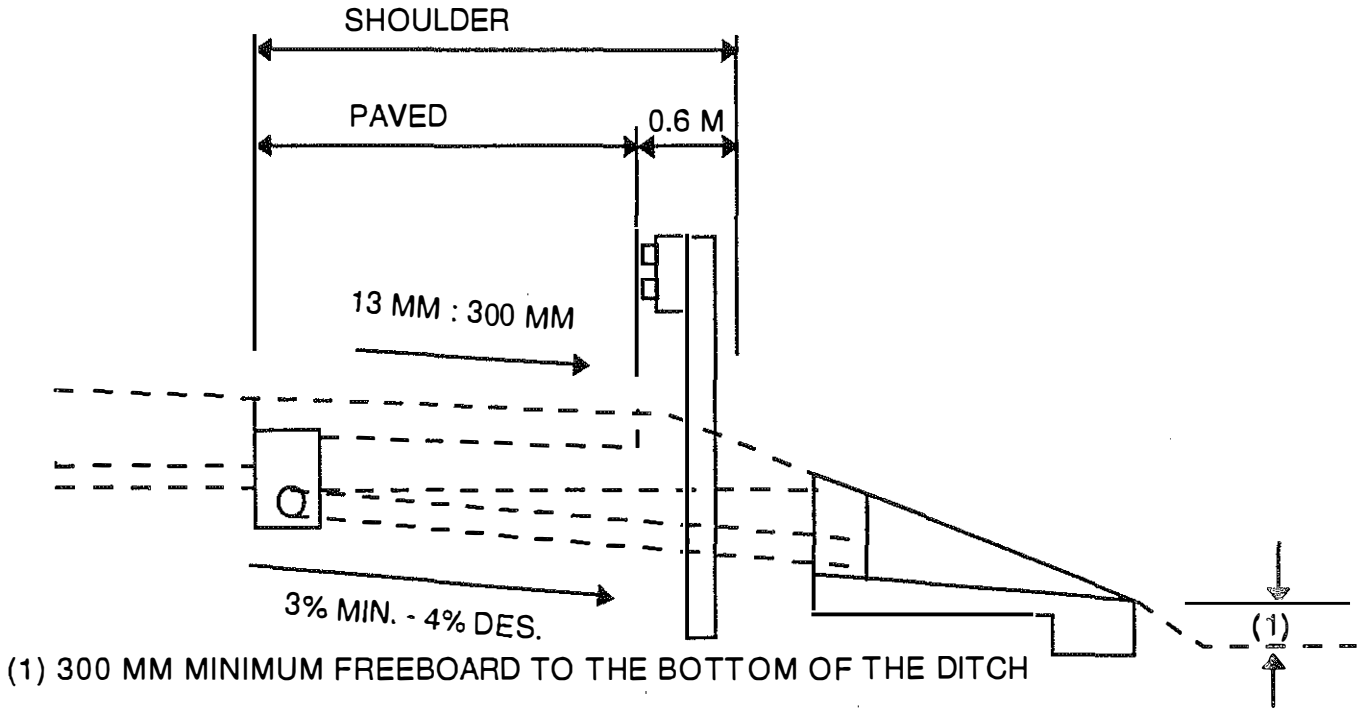

DRAWING NO. 2

LONGITUDINAL PAVEMENT EDGE DRAIN (PERFORATED PIPE)

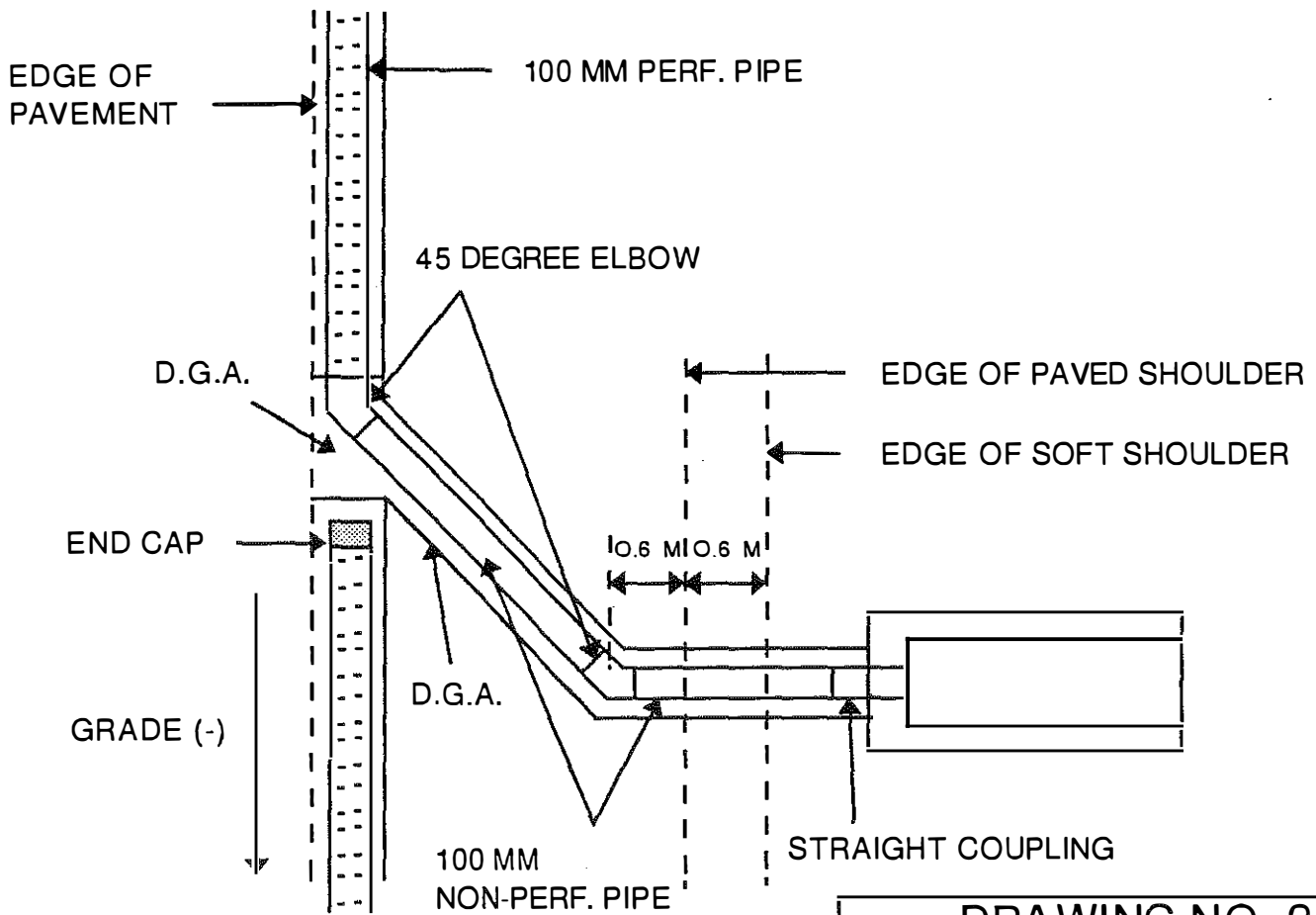
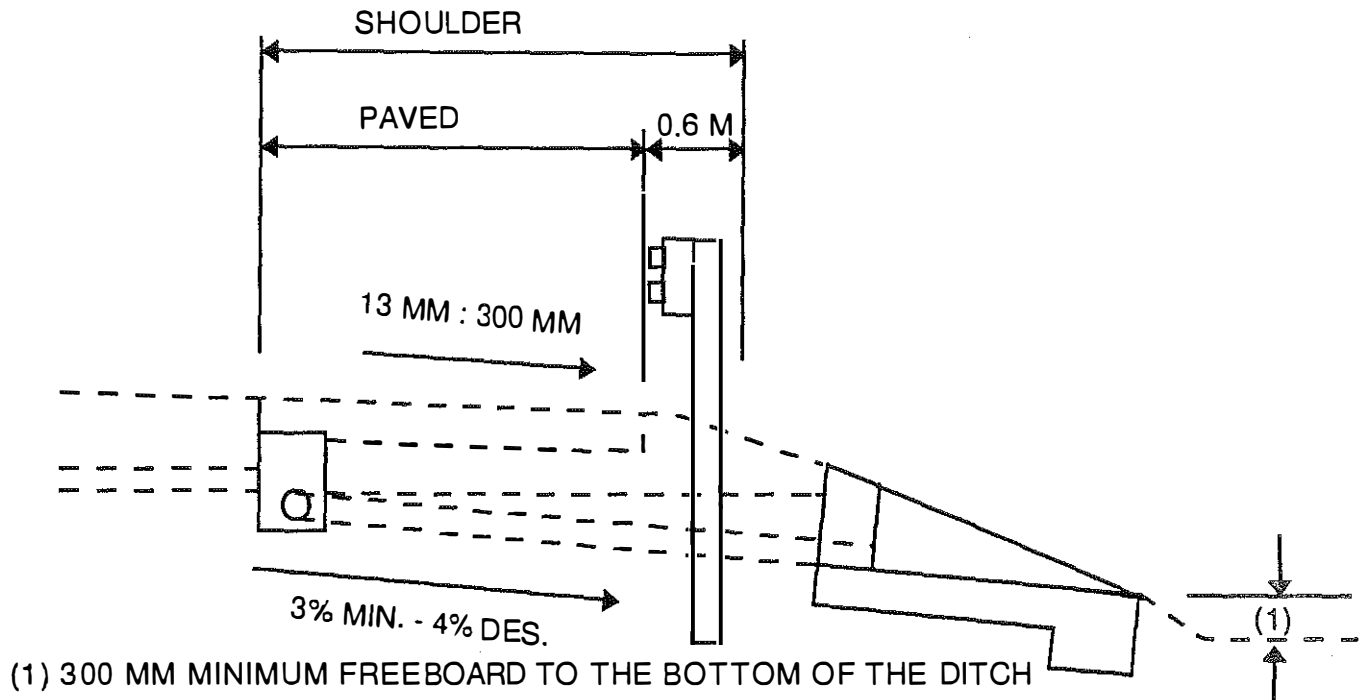

DRAWING NO. 2

TYPICAL DETAIL FOR OUTLET SPACING AT SAG

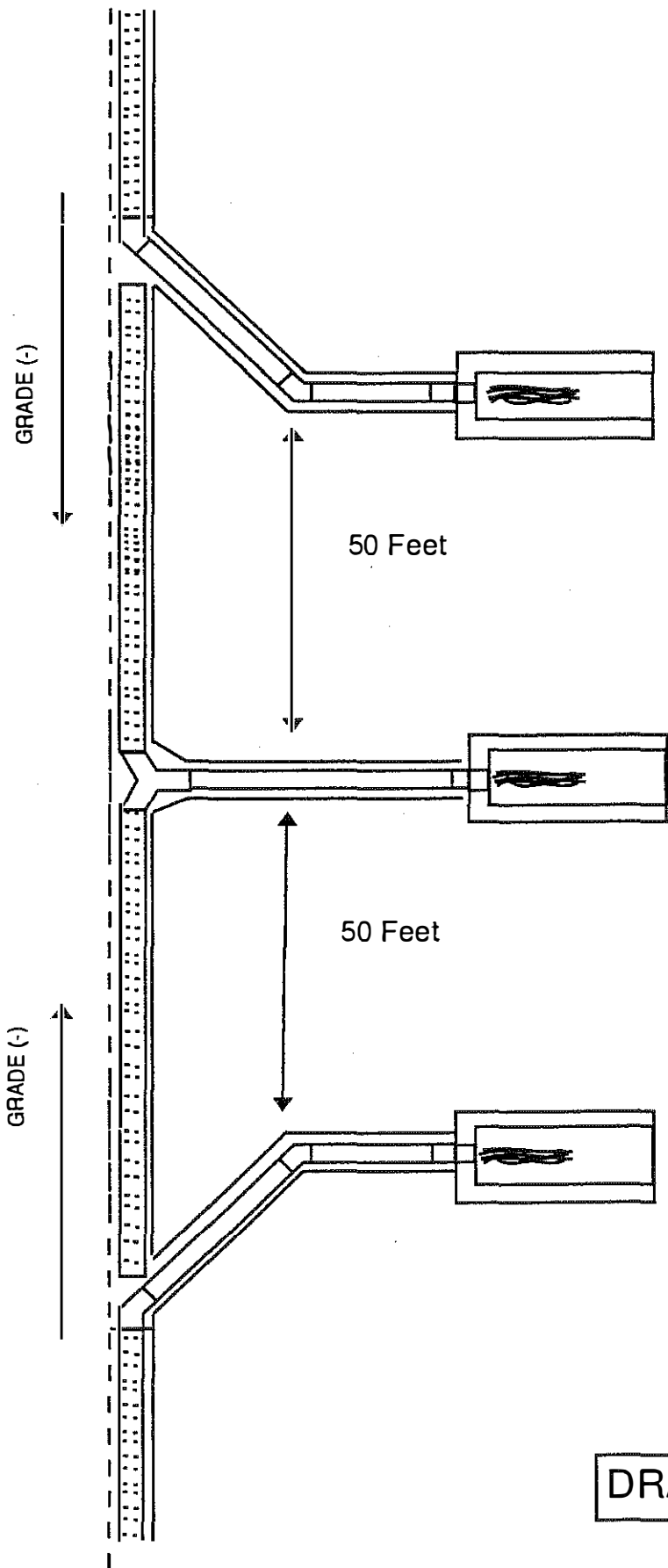

DRAWING NO. 3

**SPECIAL PROVISION FOR
PREFABRICATED PAVEMENT EDGE PANEL DRAIN**

SPECIAL PROVISION FOR PREFABRICATED PAVEMENT EDGE PANEL DRAIN

I. DESCRIPTION

This Special Provision shall apply when indicated on the plans or in the proposal. Section references herein are to the Department's current Standard Specifications for Road and Bridge Construction. This work shall consist of furnishing and installing a prefabricated edge panel drain in accordance with this Special Provision and as directed by the Engineer.

II. MATERIALS

A. General. The core of the prefabricated edge panel drain shall be rigid or semi-rigid high density polyethylene (HDPE) or polyvinylchloride (PVC). It shall be surrounded by a geotextile fabric conforming to Table II of Section 845.02. The core of the panel shall be chemically resistant to petroleum based chemicals, as well as naturally occurring soils. The panel drain shall have an inside cross-sectional thickness from 13 to 25 mm and a depth of from 300 to 450 mm.

B. Acceptance. The open area on the side of the core used for drainage shall be no less than 5 percent of the total core area in accordance with Drawing No. 1. The compressive strength of the core shall be no less than 138 kPa at 10 percent strain as determined by Standard Test Method ASTM D 1621. The cross-sectional area of the core shall not decrease more than 10 percent under a 156-kPa vertical load and the core shall not deflect more than 5 percent along the vertical axis (as installed) as determined by KM 64-XXX-92. In addition, the panel shall have a flow capacity of 30 gallons per minute at 3% grade.

III. CONSTRUCTION REQUIREMENTS

A. Inspection, Handling, and Storage. The prefabricated edge panel drain, and fittings shall be inspected upon receipt at the job site. The shipment shall be inspected for conformance to product specifications, contract documents, and checked for damage. Damaged or deformed material shall be removed from the job site. The material shall be stored to prevent damage. The material shall be stored away from exposure to ultraviolet light and direct sunlight.

B. Installation of Edge Drain. The prefabricated edge panel drain shall be installed in a trench as shown on Drawing No. 2 and 3. The prefabricated edge panel drain shall be installed on the shoulder side of the trench. A clean neat edge shall be cut in the existing bituminous pavement before excavating the trench. The top of the panel shall not be installed in a position higher than the center point of the existing pavement. When the panel is installed above this point, it shall be removed and replaced at the Contractor's expense. Panel designs that are not symmetrical about the vertical axis when installed shall be installed with the rigid or semi-rigid back facing the sand backfill.

Splices, when required, shall be made prior to placing the panel drain in the trench. Splices shall be made using splice kits furnished by the manufacturer and in accordance with the manufacturer's written instructions. Assembly of joints shall not damage the panel and shall not

impede the open flow area of the panel, and retain the vertical and horizontal alignment of the drain. The joints shall prevent infiltration of the backfill or any fine material.

The prefabricated edge panel drain shall be connected to outlet pipes before the trench is backfilled. The trench shall be backfilled with a natural sand that has a gradation conforming to subsection 804.03.02. The sand shall be dried in a hot-mix bituminous plant drier or by similar means so that the sand is free flowing.

Means shall be provided to hold the prefabricated edge panel drain flush against the trench wall during sand backfilling. The sand may be slurried into the trench in one pass with a water application rate of approximately 3.5 litres per 300 mm of trench. The Contractor shall gauge the water supply. The Engineer will record the gauge reading at least once per 150 m of trench.

The final elevation of the sand backfill shall be at least 25 mm above the top of the prefabricated edge panel drain. When this requirement is not met, the Contractor shall slurry in additional sand.

C. Installation of Edge Drain Outlets. Outlets shall be constructed at the locations shown on the plans or as directed by the Engineer. Outlet fittings to transition from the prefabricated edge panel drain to a non-perforated 102-mm smooth lined rigid pipe shall be furnished by the manufacturer, and shall be installed in accordance with the manufacturer's written instructions. The connection of the prefabricated edge panel drain to an outlet pipe shall be made with a 45-degree elbow and bending of the panel drain shall not be permitted. At the sags of vertical curves, the pipe drain may be connected to the outlet pipe with a "Y" connector. An additional outlet shall be placed 50 feet on each side of the headwall in the center of the sag (Drawing No. 4). The connection from the pipe drain to the outlet pipe shall be securely connected without impeding the flow.

The outlet pipe leading to the headwall from the prefabricated pavement edge drain panel shall be one of the following alternates:

- 1) Corrugated Polyethylene Pipe Type S, meeting the requirements of AASHTO M 252 (Landfill Grade, Pipe Stiffness 71-72).
- 2) PVC pipe meeting the requirements of either ASTM D 1785 for schedule 40 or ASTM D 2241 for SDR 17.
- 3) Corrugated steel or corrugated aluminum pipe meeting the requirements specified in Section 705.
- 4) Ribbed PVC pipe meeting the requirements of ASTM F 794 Series 46.
- 5) Corrugated PVC pipe meeting the requirements of ASTM F 949.

The outlet pipe which is chosen by the contractor from the five alternates shall also be precast into the headwall to allow for a smooth transition from the outlet to the headwall. Headwalls not utilizing one of the five alternates are not acceptable and will be removed at the contractors expense.

All outlet pipe shall be 100-mm diameter, unless otherwise noted on the plans or in the proposal. Care shall be exercised to prevent sags, tears, or compression in the outlet pipes. Trenches excavated for outlet pipes shall be backfilled with dense-graded aggregate.

The outlet pipe shall be installed at a desired 4 percent grade, or 3 percent minimum to insure positive outflow.

All material removed from the trench which is not used for other purposes required by the contract or as specified or permitted by the Engineer, shall be removed from the project site at no additional cost to the Department.

For those situations where guardrail will be attached to a structure, such as a bridge end or a pier, the placement of the outlet pipe shall be adjusted such that the guardrail posts will not be driven within a horizontal distance of not less than 300 mm of the outlet pipe for prefabricated pavement edge panel drains.

Where guardrail is not attached to a structure, the placement of the guardrail posts and/ or the outlet pipe shall be adjusted such that the guardrail posts are not driven within a horizontal distance of not less than 300 mm of the outlet pipe for prefabricated pavement edge panel drains.

The Contractor shall mark the location of the outlet pipe for prefabricated edge panel drains with paint or by other means as approved by the Engineer.

Damage to the outlet pipe for prefabricated pavement edge panel drains by guardrail installation shall be acceptably repaired or the damaged outlet pipe shall be removed and replaced by the Contractor, at no additional cost to the Department.

The outlet pipe headwall shall conform to Standard Drawing No. RDP-010-04. The pipe used in the headwall shall conform to the outlet pipe. The site for the headwall shall be undercut by 200 mm and backfilled with DGA. The DGA shall be mechanically compacted to achieve maximum density. The prepared surface for the headwall shall be constructed so that after placement of the headwall the headwall slopes 13 mm per 300 mm for positive outlet flow from the headwall. If settlement occurs in the headwall prior to final inspection, the contractor shall reset the headwall at his expense. The headwall shall also have a minimum of 150 to 300 mm of freeboard from the base of the headwall trough to the bottom of the ditch.

In addition to the requirements of Standard Drawing No. RDP-010-04, a quantity of Crushed Aggregate Size No. 2 as conforming to Section 805 shall be used at all pavement subsurface drainage pipe headwall outlets. The Crushed Aggregate Size No. 2 shall be placed a minimum depth of 100 mm. The stone shall be placed a lateral distance of 0.6 m from the sides and the top of the headwall and for a distance of 1.2 m from the toe of the headwall.

Dense Graded Aggregate (DGA) removed to allow placement of the Crushed Aggregate Size No. 2 shall be used to dress existing shoulders where DGA is exposed. Other material removed to allow placement of the Crushed Aggregate Size No. 2 shall be disposed of as directed by the Engineer. No direct payment will be allowed for disposal of removed material.

D. Inspection of Edge Drain Mainline and Outlet. The final product will be inspected using a borescope and mini camera. The outlet pipe shall be inspected with a mini camera. The outlet pipe shall not be deflected greater than 5 percent, and shall be free of tears, debris, and sags.

The pavement edge drain and the outlet pipe shall be inspected (by State or contract personnel supervised by the Resident Engineer) using a borescope or miniature pipeline inspection camera. The panel shall be flush against the wall of the trench and placed at the designated height. The panel shall not be bent, J'd, or damaged in any fashion that would reduce flow. The geotextile fabric surrounding the drain shall be free of rips or punctures. When the panel or the outlet pipe is not properly installed, the panel or the outlet shall be removed and replaced at the Contractor's expense.

E. Adjustment of Quantities. The Engineer reserves the right to make increases or decreases in the quantity of prefabricated edge panel drain constructed as may be required, in accordance with Section 104.02

IV. METHOD OF MEASUREMENT AND BASIS OF PAYMENT

The prefabricated edge panel drain will be measured linearly in meters complete and accepted in the final work. Payment for the accepted quantity at the contract unit price for prefabricated edge panel drain will be full compensation for prefabricated edge panel drain trench excavation; backfill, including dried natural sand and water; furnishing and installing all prefabricated edge panel drain materials, including splices and fittings; and all equipment, labor, and incidentals necessary to complete the work.

Outlet pipe, outlet pipe headwall, bituminous mixtures, and other items required by the contract will be measured and paid for as specified elsewhere in the contract.

The contract unit price for Crushed Aggregate Size No. 2 will be full compensation for all materials, labor, and other incidentals necessary to place Crushed Aggregate Size No. 2 for control of vegetation and erosion at prefabricated pavement edge panel drain outlet pipe headwalls.

TYPICAL PREFABRICATED EDGE PANEL DRAIN DESIGN

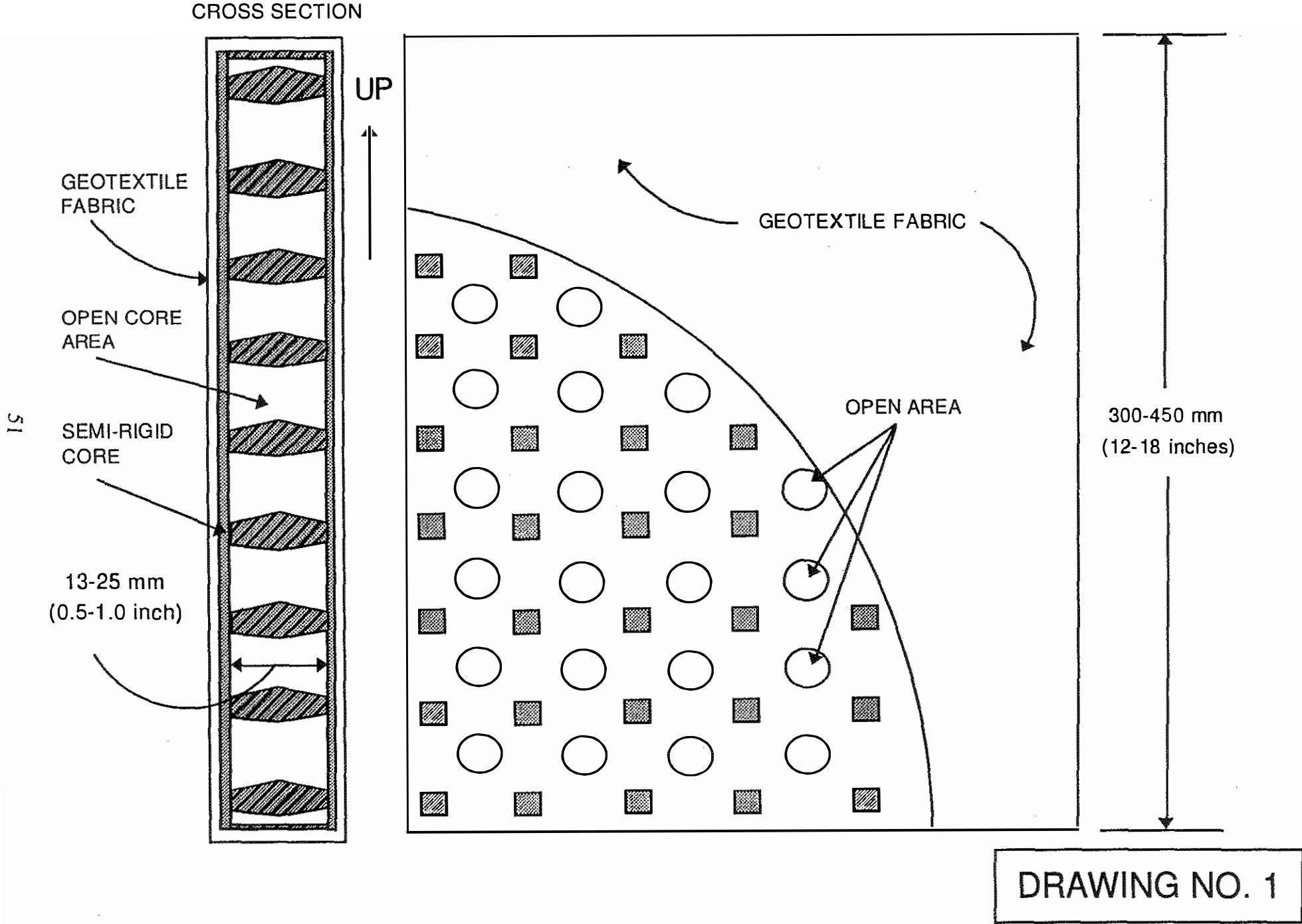

TYPICAL DETAIL FOR INSTALLATION OF PREFABRICATED PAVEMENT EDGE PANEL DRAINS

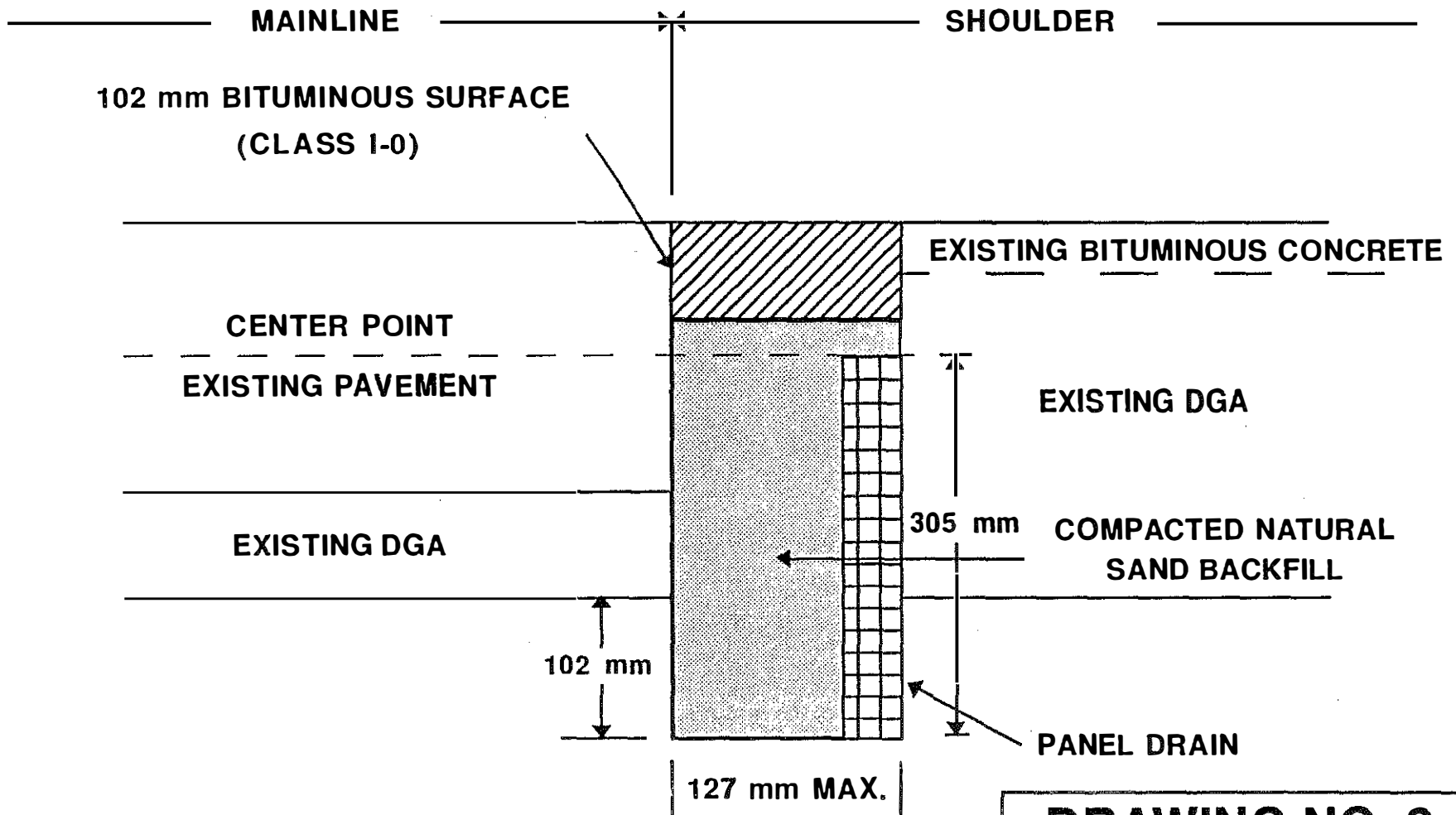

DRAWING NO. 2

LONGITUDINAL PAVEMENT EDGE DRAIN (PANEL DRAIN)

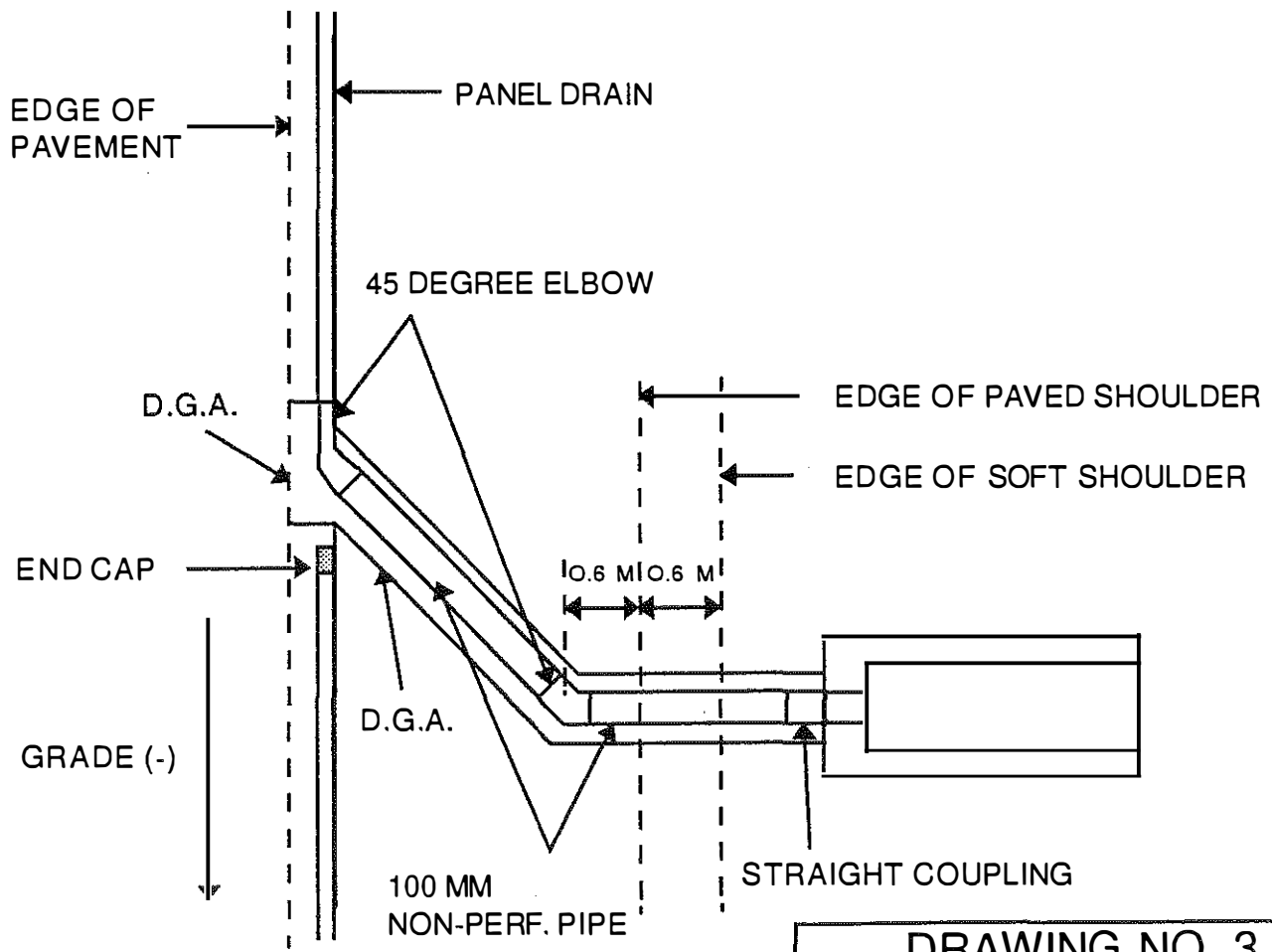
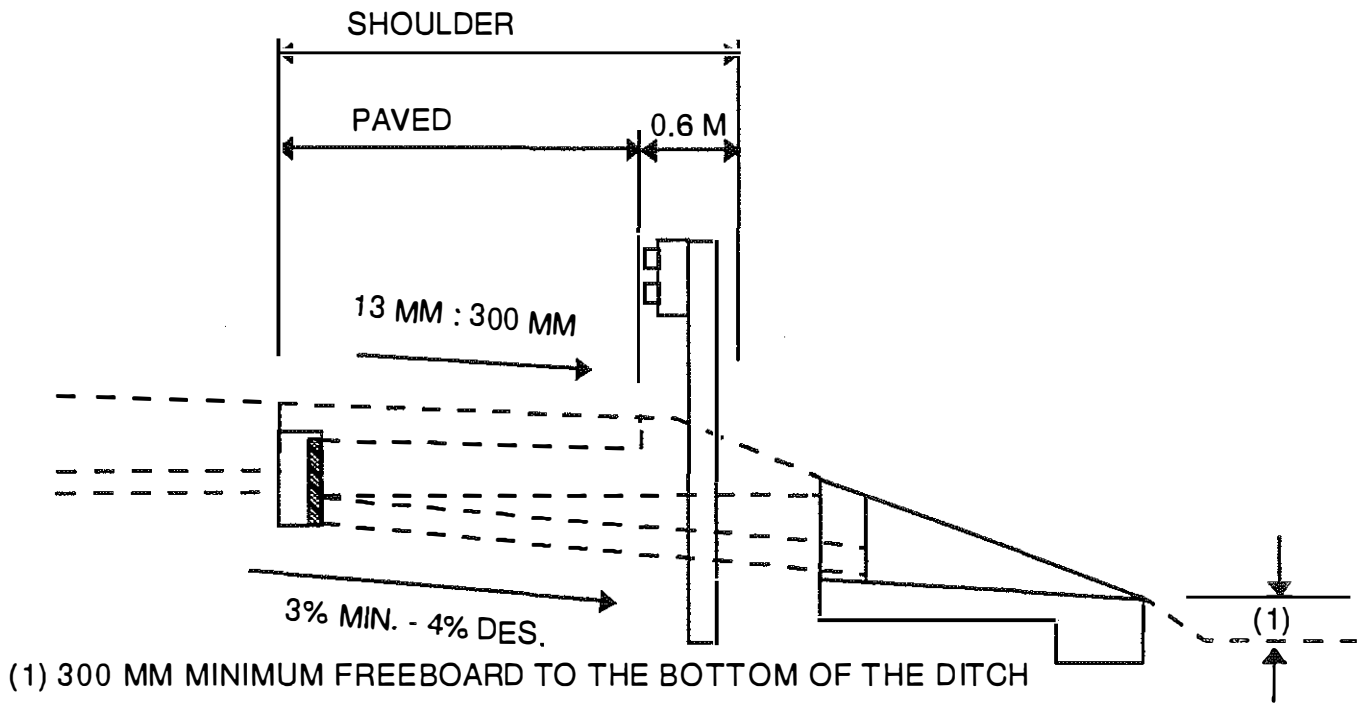

DRAWING NO. 3

TYPICAL DETAIL FOR OUTLET SPACING AT SAG

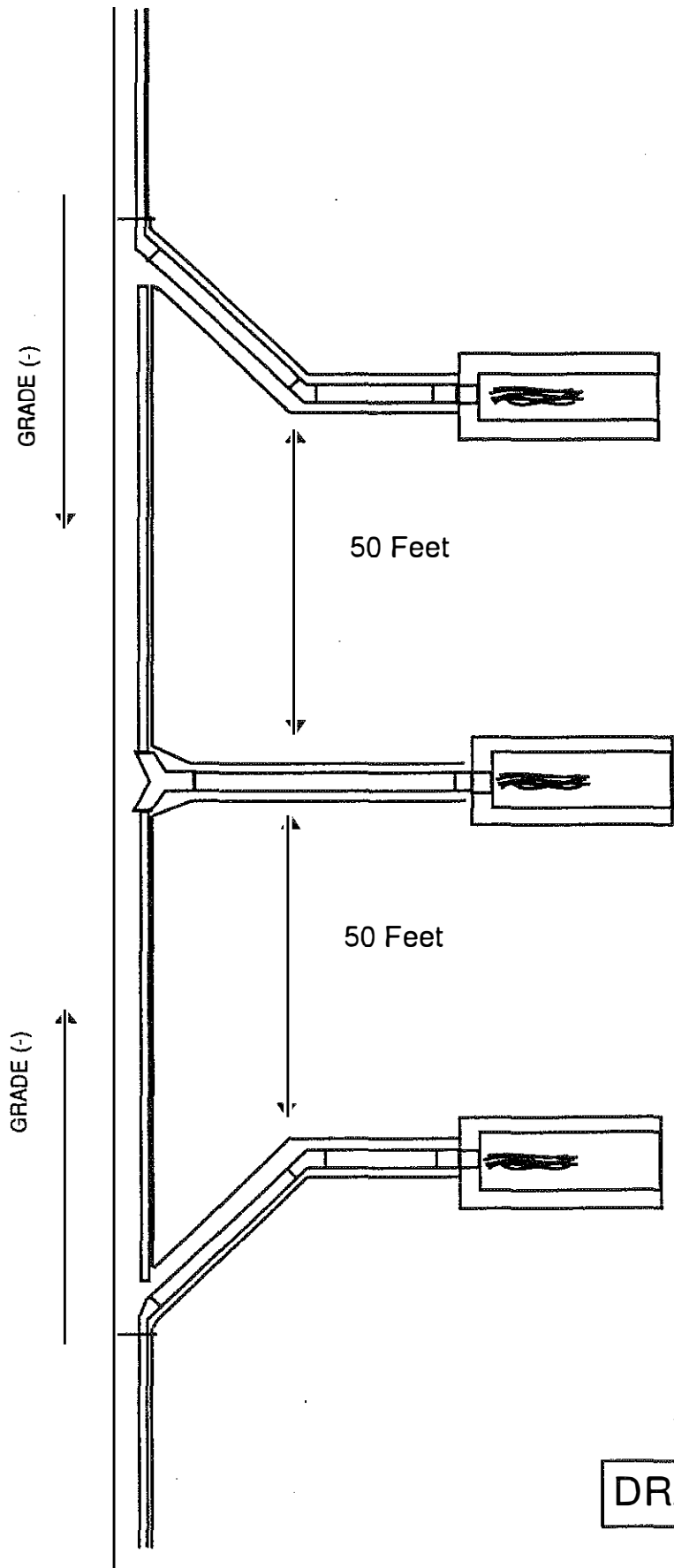

DRAWING NO. 4

VERTICAL COMPRESSION TEST OF PAVEMENT EDGE PANEL DRAINS
Kentucky Method
64-XXX-92

VERTICAL COMPRESSION TEST OF PAVEMENT EDGE PANEL DRAINS

1. SCOPE -

1.1 This method covers a procedure for determining the behavior of pavement edge panel drains in vertical compression, when encapsulated in a natural sand backfill. The test measures the loss of core volume.

1.2 Application - This method shall apply to all panel or fin-type pavement edge drains. This may include but not be limited to all cusped types, those types with posts, types that are similar to deformed pipe, and any other design.

2. APPARATUS -

2.1 Compression Machine - A compression machine that is capable of at least 454 kg. The machine must be capable of loading at a rate of 45 kg per minute, and maintaining a constant load for an indefinite period.

2.2 A Compression Box - The box must be capable of holding the specimen and sand backfill, and it must be capable of supporting a minimum vertical load of 450 kg. The design of the box shall conform to the attached Figure 1.

2.3 Clear plastic spacers (shown and described in Figure 2). These are used to protect the tempered glass ends of the compression box from scratches.

2.4 Sand - Sufficient sand to fill the compression box. Natural sand is recommended. The sand shall have a gradation conforming to subsection 804.03.01 of the Kentucky Standard Specifications for Road and Bridge Construction (1991 Edition).

2.5 Tracing Paper - The paper must be suitable for tracing and have a minimum size of 220 mm by 350 mm.

2.6 Light Source - Any strong light source is acceptable.

2.7 A 3.75 liter container.

2.8 Planimeter - This is to calculate loss of core area after test. If computer digitizing equipment is available, this may be used in lieu of the planimeter.

2.9 Length Measuring Device - A minimum range of 450 mm, and a precision of 1.00 mm.

3. SAMPLE -

- 3.1 The sample core shall be approximately 300 mm in height and 300 mm in length.
- 3.2 If the sample to be tested is 450 mm in height, the sample shall be cut to 300 mm.
- 3.3 When sampling, the geotextile shall be cut approximately 6.00 mm longer than the core (at both ends of the core).
- 3.4 The geotextile covering the core shall be intact. There shall not be any tears or punctures, and if the textile is normally glued to the core for a particular design, it shall remain glued for this test.

4. PROCEDURE -

- 4.1 The plastic spacers are placed next to the tempered glass ends of the box. This helps to prevent the sand from scratching the glass ends. The plastic spacers may be considered expendable since it may become necessary to replace them after several tests, due to scratching by the sand.
- 4.2 The sample is placed in an upright position in the compression box, against one sidewall of the box.
- 4.3 The 6.00 mm excess geotextile at the ends of the core shall be lapped as shown in Figure 2. This helps to prevent sand from flowing between the end of the core and the glass endwall.
- 4.4 Pour the dry sand into the compression box to a height of at least 100 mm above the top of the core of the panel. Make no attempt to densify the sand.
- 4.5 Smooth the surface of the sand to make it as level as possible.
- 4.6 Place the loading plate (Figure 1) onto the sand surface, and then place the entire compression box into the testing machine.
- 4.7 With the scale, measure accurately and record the height of the panel core.
- 4.8 With the light source shining through the open core from one glass end of the compression box, place a piece of tracing paper on the opposite end of the box and trace the open area of the core.
- 4.9 Begin loading the sand backfill and core at a rate of 45 kg per minute. When the load has reached 113 kg, hold the load constant, measure the height of the core, and repeat Step 4.8.
- 4.10 After Step 4.9 is completed, continue loading the sample at the same rate designated in Step 4.9 until the load reaches 227 kg. Repeat Step 4.8. Repeat the same procedures when the load reaches 340 kg and 454 kg.
- 4.11 Remove the compression box from the testing machine. Remove the sand, the sample,

and the plastic spacers.

4.12 Flush all of the remaining sand from the compression box. Use liberal amounts of water.

CAUTION: DO NOT WIPE THE GLASS ENDS WITH A CLOTH OR PAPER TOWEL UNTIL CERTAIN ALL SAND HAS BEEN REMOVED, AS THIS WILL SCRATCH THE GLASS.

4.13 Completely dry the interior of the compression box.

4.14 Repeat Steps 4.1 through 4.4 with a fresh sample.

4.15 Densify the sand by pouring 3.75 litres of water into the box and wait until all of the free water has drained from the box. This may take several minutes.

4.16 Repeat Steps 4.5 through 4.13.

5. CALCULATIONS -

5.1 The decrease in the area of the core with increasing load, and the decrease in the height of the core are calculated.

5.2 Determine vertical stress on the horizontal sand surface (located under the immediately under the loading plate) at each load level as follows:

$$\text{Stress} = (\text{load}) / (\text{Area of sand surface}).$$

For Example:

$$\text{Stress} = (1.112 \text{ kN}) / (0.0284 \text{ m}^2) = 39.15 \text{ kPa}$$

5.3 From the tracing made at each load level, use planimeter or digitizing equipment to determine open area of core at each load level. This is to be done for the dense (wet) and loose (dry) sand tests.

5.4 Determine the percent change in area of the core at each load level (for dense and loose sand) as follows:

$$A_D = [(A_0 - A_L) / (A_0)] \times 100$$

where

A_D = Change in area (percent),

A_0 = Initial area at zero load, and

A_L = Area at a particular load.

5.5 Determine percent change in core area between dense and loose sand at each load level as follows:

$$A_c = [(A_{DL} - A_{LL}) / (A_{DL})] \times 100$$

where

A_c = Change in core area between dense and loose sand (percent),

A_{DL} = Area of core for dense sand at a particular load, and

A_{LL} = Area of core for loose sand at a particular load.

5.6 Plot percent change in core area (A_D) as a function of stress for each load level and both dense and loose sand.

5.7 Plot percent change in core area between dense and loose sand (A_c) as a function of stress at each load level.

5.8 Calculate percent change in height as follows:

$$H_D = [(H_i - H_f) / (H_i)] \times 100$$

where

H_D = Change in height (percent),

H_i = Initial height of core, and

H_f = Final height of core.

5.9 Plot percent change in height (H_D) as a function of stress at each load level.

6. REPORT -

6.1 Report the percent change in core area at a stress level of 100 kPa for dense sand.

6.2 Report the percent change in core area at a stress level of 100 kPa for loose sand.

6.3 Report the percent change in core area between dense and loose sand at a stress level of 100 kPa.

6.4 Report the percent change in height of the core at a stress level of 100 kPa.

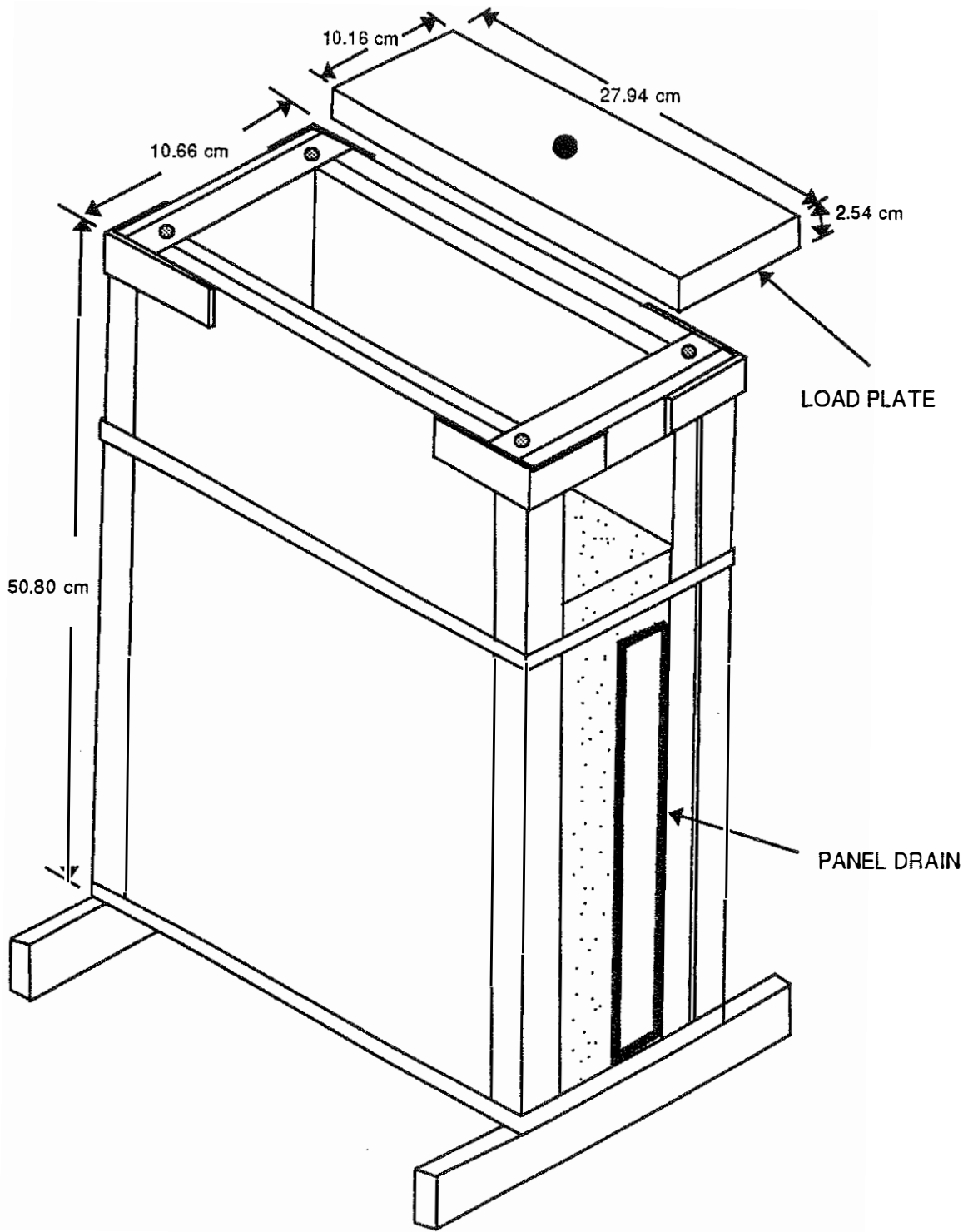

FIGURE 1. EDGE DRAIN COMPRESSION CHAMBER

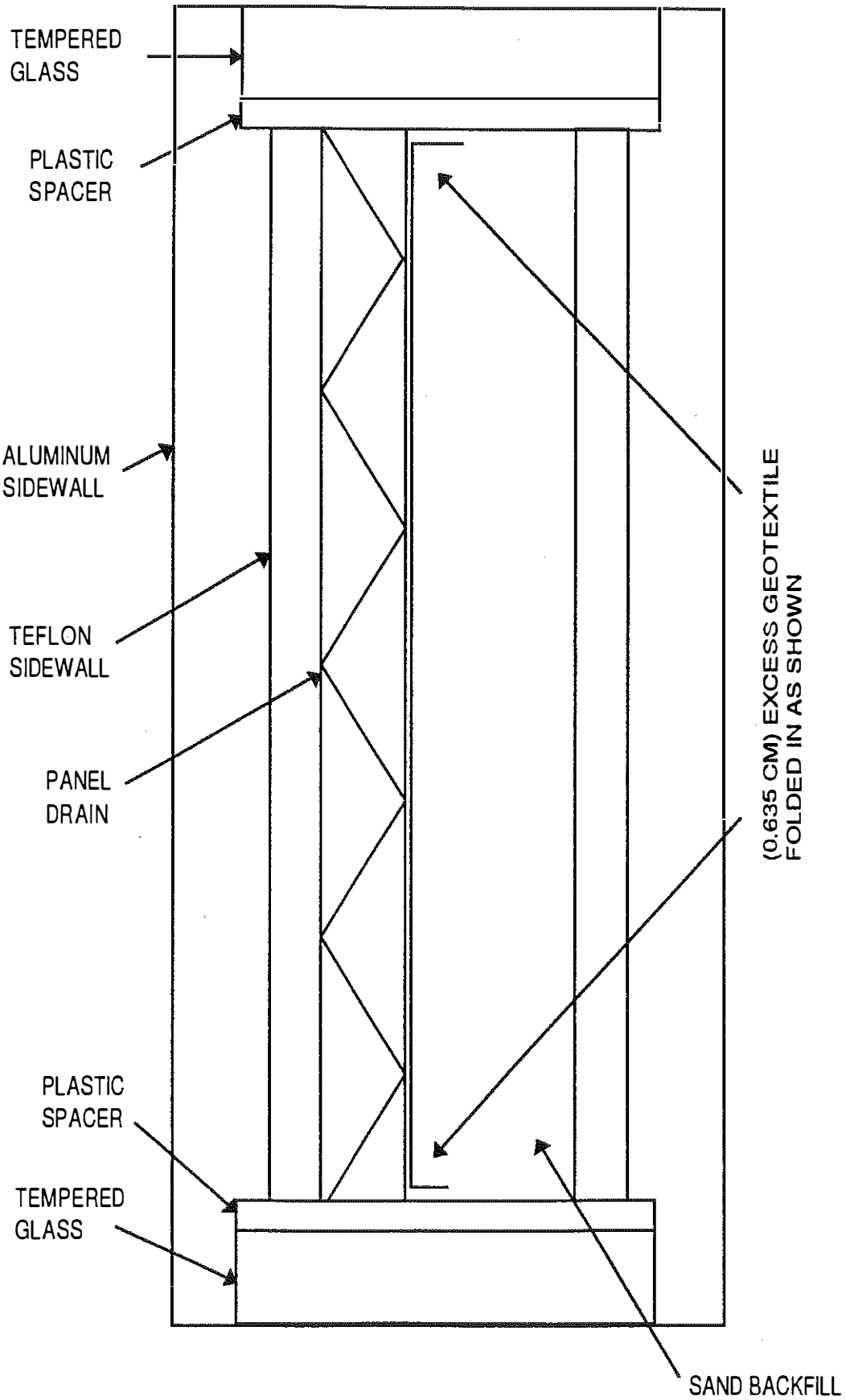

FIGURE 2. TOP VIEW OF COMPRESSION CHAMBER