



University of Kentucky  
UKnowledge

---

Theses and Dissertations--Chemical and  
Materials Engineering

Chemical and Materials Engineering

---

2014

## A MULTIDISCIPLINARY TECHNO-ECONOMIC DECISION SUPPORT TOOL FOR VALIDATING LONG-TERM ECONOMIC VIABILITY OF BIOREFINING PROCESSES

Sumesh Sukumara

University of Kentucky, pansumesh@gmail.com

[Right click to open a feedback form in a new tab to let us know how this document benefits you.](#)

---

### Recommended Citation

Sukumara, Sumesh, "A MULTIDISCIPLINARY TECHNO-ECONOMIC DECISION SUPPORT TOOL FOR VALIDATING LONG-TERM ECONOMIC VIABILITY OF BIOREFINING PROCESSES" (2014). *Theses and Dissertations--Chemical and Materials Engineering*. 42.

[https://uknowledge.uky.edu/cme\\_etds/42](https://uknowledge.uky.edu/cme_etds/42)

This Doctoral Dissertation is brought to you for free and open access by the Chemical and Materials Engineering at UKnowledge. It has been accepted for inclusion in Theses and Dissertations--Chemical and Materials Engineering by an authorized administrator of UKnowledge. For more information, please contact [UKnowledge@lsv.uky.edu](mailto:UKnowledge@lsv.uky.edu).

## **STUDENT AGREEMENT:**

I represent that my thesis or dissertation and abstract are my original work. Proper attribution has been given to all outside sources. I understand that I am solely responsible for obtaining any needed copyright permissions. I have obtained needed written permission statement(s) from the owner(s) of each third-party copyrighted matter to be included in my work, allowing electronic distribution (if such use is not permitted by the fair use doctrine) which will be submitted to UKnowledge as Additional File.

I hereby grant to The University of Kentucky and its agents the irrevocable, non-exclusive, and royalty-free license to archive and make accessible my work in whole or in part in all forms of media, now or hereafter known. I agree that the document mentioned above may be made available immediately for worldwide access unless an embargo applies.

I retain all other ownership rights to the copyright of my work. I also retain the right to use in future works (such as articles or books) all or part of my work. I understand that I am free to register the copyright to my work.

## **REVIEW, APPROVAL AND ACCEPTANCE**

The document mentioned above has been reviewed and accepted by the student's advisor, on behalf of the advisory committee, and by the Director of Graduate Studies (DGS), on behalf of the program; we verify that this is the final, approved version of the student's thesis including all changes required by the advisory committee. The undersigned agree to abide by the statements above.

Sumesh Sukumara, Student

Dr. Jeffrey R. Seay, Major Professor

Dr. Thomas Dziubla, Director of Graduate Studies

A MULTIDISCIPLINARY TECHNO-ECONOMIC DECISION SUPPORT  
TOOL FOR VALIDATING LONG-TERM ECONOMIC VIABILITY OF  
BIOREFINING PROCESSES

---

DISSERTATION

---

A dissertation submitted in partial fulfillment of the  
requirements for the degree of Doctor of Philosophy in the  
College of Engineering  
at the University of Kentucky

By

Sumesh Sukumara

Lexington, Kentucky

Director: Dr. Jeffrey R. Seay, Associate Professor of Chemical & Materials  
Engineering

Co-Director: Dr. Stephan E. Rankin, Professor of Chemical & Materials Engineering

University of Kentucky, Paducah, Kentucky

2014

Copyright © Sumesh Sukumara 2014

## ABSTRACT OF DISSERTATION

### A MULTIDISCIPLINARY TECHNO-ECONOMIC DECISION SUPPORT TOOL FOR VALIDATING LONG-TERM ECONOMIC VIABILITY OF BIOREFINING PROCESSES

Increasing demand for energy and transportation fuel has motivated researchers all around the world to explore alternatives for a long-term sustainable source of energy. Biomass is one such renewable resource that can be converted into various marketable products by the process of biorefining. Currently, research is taking strides in developing conversion techniques for producing biofuels from multiple bio-based feedstocks. However, the greatest concern with emerging processes is the long-term viability as a sustainable source of energy. Hence, a framework is required that can incorporate novel and existing processes to validate their economic, environmental and social potential in satisfying present energy demands, without compromising the ability of future generations to meet their own energy needs.

This research focuses on developing a framework that can incorporate fundamental research to determine its long-term viability, simultaneously providing critical techno-economic and decision support information to various stakeholders. This contribution links various simulation and optimization models to create a decision support tool, to estimate the viability of biorefining options in any given region. Multiple disciplines from the Process Systems Engineering and Supply Chain Management are integrated to develop the comprehensive framework. Process simulation models for thermochemical and biochemical processes are developed and optimized using Aspen Engineering Suite. Finally, for validation, the framework is analyzed by combining the outcomes of the process simulation with the supply chain models. The developed techno-economic model takes into account detailed variable costs and capital investments for various conversion processes. Subsequently, case studies are performed to demonstrate the applicability of the decision support tool for the Jackson Purchase region of Western Kentucky. The multidisciplinary framework is a unique contribution in the field of Process Systems Engineering as it demonstrates simulation of process optimization models and illustrates its iterative linking with the supply chain optimization models to estimate the economics of biorefinery from multi-stakeholder perspective. This informative tool not only assists in comparing modes of operation but also forecasts the effect of future scenarios, such as, utilization of marginal land for planting dedicated energy crops and incorporation of emerging enzymatic processes. The resulting framework is novel and informative in assisting investors, policy makers and other stakeholders for evaluating the impacts of biorefining. The results obtained supports the generalizability of this tool to be applied in any given region and guide stakeholders in making financial and strategic decisions.

**KEYWORDS:** Biorefining Supply Chains, Biofuels, Lignocellulosic Biomass,  
Sustainability, Strategic Decision Support Tool

Sumesh Sukumara

---

Student's Signature

October 06, 2014

---

Date

A MULTIDISCIPLINARY TECHNO-ECONOMIC DECISION SUPPORT TOOL  
FOR VALIDATING LONG-TERM ECONOMIC VIABILITY OF  
BIOREFINING PROCESSES

By

Sumesh Sukumara

Dr. Jeffrey R. Seay

---

Director of Dissertation

Dr. Stephan E. Rankin

---

Co-Director of Dissertation

Dr. Thomas Dziubla

---

Director of Graduate Studies

November 16, 2014

---

Date

*I dedicate this dissertation to my parents and my wife*

## ACKNOWLEDGMENTS

First of all, I would like to thank the Almighty for blessing me with extremely motivating mentors, a loving family, supporting friends and wonderful opportunities throughout my life.

I express my deepest gratitude to Dr. Jeffrey R. Seay for his continued support, trust and motivation throughout the course of this research. During the last 5 years, while working with Dr. Seay, I have learned several technical aspects and behavioral qualities which will accompany me throughout my life. Also, I would like to thank him for sharing his experience, being patient in educating and being there for me whenever I needed his advice and to share my thoughts. It is my greatest honor to be his student during the most important phase of my professional career.

I would like to extend my gratitude to Dr. Fazleena Badurdeen for her continued encouragement, guidance and involving me in the collaborative research work. Also, I would thank Dr. Stephen E. Rankin for his support and providing me with a place to work in the UK (Lexington campus). I was the only student in my research lab, but being with Dr. Badurdeen's and Dr. Rankin's lab group, I never felt it that way. I thank the professors and their respective students for always including me in their activities and making me feel like a part of their research group. I would like to express my gratitude to Dr. Barbara L. Knutson for her suggestions, guidance and involving me in the USDA research grant which further enabled me in exploring multiple attributes of this research. Also, I thank Dr. Naresh Shah for sharing his insights during the committee and research meetings. I humbly seek their blessings and wish them success in their future research and ventures. I express my gratitude to Dr. Younsoo Bae for agreeing to be the outside examiner for my PhD final examination.



In addition, I thank the Department of Chemical Engineering, the Graduate School, USEC Inc. and the USDA BRDI grant for providing financial and conference travel support since 2010. Also, I would like to thank all the professors and staff in the Department of Chemical and Materials Engineering at University of Kentucky for their assistance. My special acknowledgement to Dr. Douglas S. Kalika, Dr. Thomas Dziubla, Mr. Bruce Cole and Ms. Chelsea Hansing for always helping me with logistics.

It has been a privilege to be part of this unique research group that involved individuals from diverse professional background. I would like to thank my colleagues, William Faulkner and Joseph Amundson for sharing their acumen and helping me by adding intellectual value to our research work. Also, I thank Andrea Ramsey, Ryan Edelen and Kwabena Darkwah for working together and sharing their views during the research. I thank Abhijit Bhagavatula and Ravinder Garlapalli for often sharing their thoughts and having several productive research discussions that further helped me to broaden my knowledge in the research. I wish all of them success in their careers. I firmly believe that a graduate student's career is successful only when he/she can find the right balance between their professional and social life. I would like to thank all my friends and colleagues for their support, inspiration and the wonderful moments that we had together. My special thanks to the Gazette friends and MACE (CHMEGSA) members for providing me with opportunities for social and professional interactions.

Finally, I would like to express my sincere gratitude to my parents Raghava S. Panicker and Ramani S. Panicker, my in-laws and my sister Seema Kalidasa for supporting me throughout the course of life. My special acknowledgement to my wife Mini Kamalan for being extremely caring and helpful. I feel blessed to have such lovely family and siblings who have always been there, whenever I needed them and often made sacrifices to absorb the extra pressure on my side, making my work easier.

## TABLE OF CONTENTS

ACKNOWLEDGMENTS .....	iii
TABLE OF CONTENTS.....	v
LIST OF TABLES .....	ix
LIST OF FIGURES .....	x
Chapter 1: Introduction and Motivation .....	1
1.1 Overview.....	1
1.2 Research Contributions .....	1
Chapter 2: Background and Gaps in Current State of Knowledge.....	9
2.1 Biorefining .....	9
2.1.1 Feedstock for Biorefining.....	10
2.1.2 Conversion Processes .....	11
2.2 Challenges in Biorefining .....	13
2.2.1 Logistics.....	13
2.2.2 Conversion.....	14
2.3 Current State of Knowledge.....	15
2.3.1 Techno-Economic Models.....	16
2.3.2 Supply Chain Planning Models .....	19
2.3.3 Technology and Product Selection Superstructure.....	21
2.3.4 Multi-Objective Optimization and Optimization under Uncertainty .....	22
2.4 Summary .....	23
Chapter 3: Research Novelty .....	24
3.1 Summary .....	24
3.2 Scope of the Research.....	24
3.3 Novel Contributions.....	27
Chapter 4: Development of the Techno-Economic Framework.....	30
4.1 Motivation.....	30
4.2 Process Optimization Model.....	31
4.2.1 Feedstock Availability and Product Demand Assessment .....	31
4.2.2 Process Simulation Development.....	33
4.2.3 Heat Integration .....	58
4.2.4 Environmental Impact Assessment .....	59
4.2.5 Capital Cost .....	60
4.3 Linking of the Models.....	62
4.3.1 Supply Chain Optimization .....	63

4.3.2 Discrete Event Simulation .....	64
4.4 Techno-Economic Framework.....	65
4.5 Conclusions.....	68
Chapter 5: Designing Proof of Concept Studies – Demonstrating the Working of the Developed Multidisciplinary Decision Support Framework .....	69
5.1 Determining a Region to Perform the Case Studies .....	69
5.2 Reasoning Behind Selecting the Case Studies.....	71
5.2.1 A Proven Conversion Technique.....	72
5.2.2 An Emerging Conversion Process .....	73
5.2.3 A Hypothetical Scenario.....	73
5.2.4 Exploring the Integration Possibilities .....	74
5.3 Conclusions.....	74
Chapter 6: Economic Assessment of Thermochemical Conversion Process- A Case Study on Biomass Gasification .....	75
6.1 Summary .....	75
6.2 Introduction.....	76
6.3 Background.....	76
6.4 Multidisciplinary Methodology in Developing Region Specific Model .....	81
6.5 Case Study .....	84
6.5.1 Feedstock Location Assessment.....	85
6.5.2 Optimization of Transportation Network .....	86
6.5.3 Process Simulation and Optimization.....	87
6.5.4 Overall Economic Optimization.....	93
6.6 Results and Discussions .....	95
6.7 Learnings and Future Directions.....	101
6.7.1 Addition of Biochemical Process Optimization Models .....	101
6.7.2 Heat Integration .....	102
6.7.3 Environmental Analysis .....	102
6.7.4 Societal Impacts.....	103
6.8 Conclusions.....	104
Chapter 7: Economic Assessment of Biological Conversion Process – A Case Study on Fermentation of Corn Stover to Ethanol.....	106
7.1 Summary .....	106
7.2 Introduction.....	107
7.3 Background.....	108
7.4 Methods and Modeling Approaches .....	110

7.5 Proof of Concept .....	112
7.5.1 Steady State Process Simulation and Optimization Model .....	114
7.5.2 Supply Chain Optimization .....	117
7.5.3 Discrete Event Simulation Model.....	118
7.6 Results, Analysis and Discussions .....	119
7.7 Conclusions.....	126
Chapter 8: Diverse Applications of the Decision Support Tool .....	128
8.1 Studies Demonstrating Applications and Interfacing of the Multidisciplinary Framework .....	128
8.2 Marginal Land Utilization.....	129
8.2.1 Introduction .....	129
8.2.2 Background.....	130
8.2.3 Methodology.....	132
8.2.4 Results and Discussions.....	136
8.2.5 Conclusions and Future Research Directions .....	139
8.3 Interfacing the Model with User-Specified Details .....	140
8.4 Potential to Link the Models Using Visual Basic® Applications .....	142
8.5 Conclusions.....	145
Chapter 9: Conclusions and Future Work .....	146
9.1 Summary of Achievements.....	146
9.2 Conclusions.....	147
9.3 Future Work.....	148
Appendix A.....	151
A.1 Reactions and corresponding parameters in the chemical pre-treatment section [54].....	151
A.2 Reactions involve in saccharification and fermentation section [54] .....	152
A.3 Detailed description of equation 6.2 Sukumara <i>et al.</i> 2013[A modified version of Faulkner 2012].....	154
Appendix B .....	157
B.1 Process conditions for feed flexible gasification.....	157
B.2 Summary of capital costs .....	158
B.3 (a) Variable feed costs.....	158
B.3 (b) Varying utility costs.....	159
B.4 Cumulative yearly cash flow including capital investment .....	159
B.5 Potential environmental impact comparison using the Waste Reduction Algorithm.....	160

B.6 Jobs created for the biochemical conversion process.....	160
Appendix C.....	161
C.1 Equations and notations used for showing the objective function and constraints .....	161
C.2 Feed data discussed in section 7.6 to begin various iterations for the case study	162
Appendix D.....	163
D.1 Predicted optimum configuration based on the preliminary assessment .....	163
D.2 FORTRAN code used to incorporate the user specified into the process simulation based on the kinetics from the literature (Kadam <i>et al.</i> 2004).....	163
D.3 Snapshots showing the methodology of accessing the simulation and the optimization models from the Microsoft Excel® interface. ....	168
References.....	170
Vita.....	183

## LIST OF TABLES

Table 4.1 Feed proximate analysis data obtained from various sources.....	35
Table 4.2 Feed ultimate analysis data .....	35
Table 4.3 Reactions occurring in the gasifier. Adapted from the previous contribution, Sutton <i>et al.</i> (2001) [119].....	38
Table 4.4 Composition of corn stover [54] .....	46
Table 4.5 Costs assigned to products for the biomass gasification process [136].....	55
Table 4.6 Price of streams for the biological conversion process [54] .....	55
Table 4.7 Utility costs used for the developed simulations [123, 136].....	55
Table 4.8 Assumed feedstock costs for the developed simulations.....	55
Table 4.9 Notations and subscript indices .....	57
Table 5.1 Calculated monthly portfolio for feedstock requirement in the Jackson Purchase region .....	71
Table 6.1 Calculated feedstock requirement portfolio in the Jackson Purchase region .....	88

## LIST OF FIGURES

Figure 1.1 Current and future energy consumption by various sectors [2] .....	2
Figure 1.2 Complex supply chain of a biorefinery from feed source to end users .....	5
Figure 2.1 Biorefining pathways for various potential bio-based feedstock .....	13
Figure 4.1 The FORTRAN code in the calculator window (Aspen Plus®) to convert the “non-conventional” feed to “conventional” composition .....	36
Figure 4.2 Process flow diagram (Aspen Plus®) for the biomass gasification unit ....	38
Figure 4.3 Process flow diagram (Aspen Plus®) of H <sub>2</sub> S cleaning section using methanol as a solvent .....	40
Figure 4.4 Process flow diagram (Aspen Plus®) of Water Gas Shift reactor segment .....	41
Figure 4.5 Process flow diagram of the Fischer Tropsch Synthesis unit.....	43
Figure 4.6 Process flow diagram (Aspen Plus®) for the hydrocarbon separation unit	44
Figure 4.7 The screenshot of the entire process to produce biofuels and power from biomass via gasification.....	45
Figure 4.8 Process flow diagram of the mechanical/physical pre-treatment section...	48
Figure 4.9 Schematic of the chemical pre-treatment section (Aspen Plus®) of corn stover.....	49
Figure 4.10 Process flow diagram (Aspen Plus®) of the saccharification and fermentation process .....	50
Figure 4.11 Schematic (Aspen Plus®) of the ethanol recovery operation.....	51
Figure 4.12 A process flow diagram (Aspen Plus®) to treat the waste water.....	52
Figure 4.13 Process flow diagram (Aspen Plus®) of the waste solid utilization section .....	53
Figure 4.14 Process flow diagram (Aspen Plus®) of the entire process to convert corn stover to ethanol.....	54
Figure 4.15 Heat exchanger network suggestion obtained from Aspen Energy Analyzer®.....	59
Figure 4.16 Methodology in which the data flows between various models to optimize the biorefining process.....	62
Figure 4.17 A simple supply chain scheme to demonstrate the scope of transportation details that will be covered in this contribution [21] .....	64
Figure 4.18 The final techno-economic framework developed, showing layers of flow of information to validate biorefining.....	67
Figure 5.1 Feedstock, potential biorefinery and product depot locations (Google Maps®) in the Jackson Purchase region [21, 22, 154] .....	70

Figure 6.1 Potential pathways for integrated biorefining [21, 102].....	78
Figure 6.2 Map showing population density [167] (top left), vehicle density (top right), corn locations (middle left), existing ethanol refineries (middle right), wood residue (bottom left) and crop residue (bottom right) locations of USA [21, 166] .....	80
Figure 6.3 Overall framework showing multidisciplinary methodology to estimate various factors for sustainable biorefining [21] .....	83
Figure 6.4 Optimization methodology used for the case study .....	85
Figure 6.5 Potential biorefinery location for small capacity estimated from the optimization model [154].....	96
Figure 6.6 Potential biorefinery location for medium capacity estimated from the optimization model [154].....	96
Figure 6.7 Potential biorefinery location for large capacity estimated from the optimization model [154].....	97
Figure 6.8 Estimated fixed capital cost for various biorefinery capacities.....	98
Figure 6.9 Annualized cash flow analysis for small, medium and large biorefinery ..	98
Figure 6.10 Cumulative cash flow analysis for small, medium and large biorefinery	99
Figure 6.11 Calculated NPV for varying capacities of biorefinery .....	100
Figure 7.1 A representation of tools, models and respective results that are generated by the framework .....	112
Figure 7.2 Algorithm to perform a case study in order to determine the optimum capacity .....	114
Figure 7.3 Process flow diagram for producing ethanol from corn stover .....	115
Figure 7.4 Potential biorefinery sites, feedstock and product depot locations in the Jackson Purchase region (Google Maps®).....	118
Figure 7.5 Monthly operating cost for various scenarios and optimum configuration .....	120
Figure 7.6 Share of various costs from the total operating cost for the optimum scenario (Result from the MILP) .....	121
Figure 7.7 Plot showing the trend of the NPV and determined optimum capacity ...	122
Figure 7.8 A graph showing sensitivity of various tested parameters. (a) Sensitivity of various costs with respect to normalized NPV. (b) Sensitivity of product prices versus average NPV .....	123
Figure 7.9 Fractional supply chain cost dynamics shown for the seventh year.....	124
Figure 7.10 A plot showing dynamic increase in the NPV.....	126
Figure 8.1 Methodology used for the case study on the marginal land utilization ....	133
Figure 8.2 Map showing potential yield (Top) of switchgrass [175]. Zoomed version (Bottom right) of marked area on the switchgrass yield map. Marginal agricultural land (Bottom left) available in the Jackson Purchase region [188] .....	135



Figure 8.3 (a) Cumulative cash flow analysis. (b) Varying monthly emissions..... 138

Figure 8.4 Proposed interfacing scheme to improve usability of the framework..... 144

# 1. Introduction and Motivation

## 1.1 Overview

Easy access to power and fuel has made our lives dependent on energy, as most of the day to day activities requires it in one form or another. In recent years, there has been a significant increase in the consumption of energy and transportation fuel. Presently, in the USA, a major portion (79.8%) of the energy demand is met by domestic and imported fossil fuels [1]. It is forecasted that by 2040, the total energy consumption of the world will increase by 56% compared with 2010 [2]. Figure 1.1 shows the current and projected increase in energy consumption by major sectors, such as, residential, commercial and transportation. Unfortunately, with limited reserves and concentration of these in specific geographic locations, the reliance on fossil fuels is susceptible to fluctuating availability (due to natural and political reasons) and price volatility. Hence, there has been an increasing urge to find a long-term solution to meet the stretching energy demand in a sustainable manner. There are many ways of producing renewable energy, amongst which biomass has intrigued many researchers due to its widespread availability and the potential to produce a wide range of products.

“A biorefinery is a facility that integrates conversion processes and equipment to produce fuels, power and chemicals from biomass” [3]. Biomass can be processed into various products through multiple conversion techniques which have the potential to replace existing fossil based production routes. In order to convert this vision into reality, it is essential to estimate the economic, environmental and social impacts of the potential biorefinery and plan long-term tactical decisions accordingly [4]. Based on thousands of years of experience in growing various edible and non-edible biomass sources, mankind has acquired expertise in its production. However, when compared with fossil fuels, the use of biomass for producing energy and chemicals possesses

various inherent disadvantages, such as, low energy density, seasonal variability, region specific availability, adapting with the varying market demand and low conversion yields [5, 6]. Nevertheless, biomass is one of the most promising renewable energy sources and has several advantages over fossil resources, such as, reduced environmental impact (based on greenhouse gas (GHG) emissions and utilization of present land for existing conversion technologies) [7, 8], reduced dependency on imported fuels and promotion of local agriculture resulting in the growth of local business and economy [9, 10]. Additionally, among the available options for renewable resources, integrated biorefining techniques stand prominent to substitute existing fossil based processes to produce transportation fuel and chemicals [11].

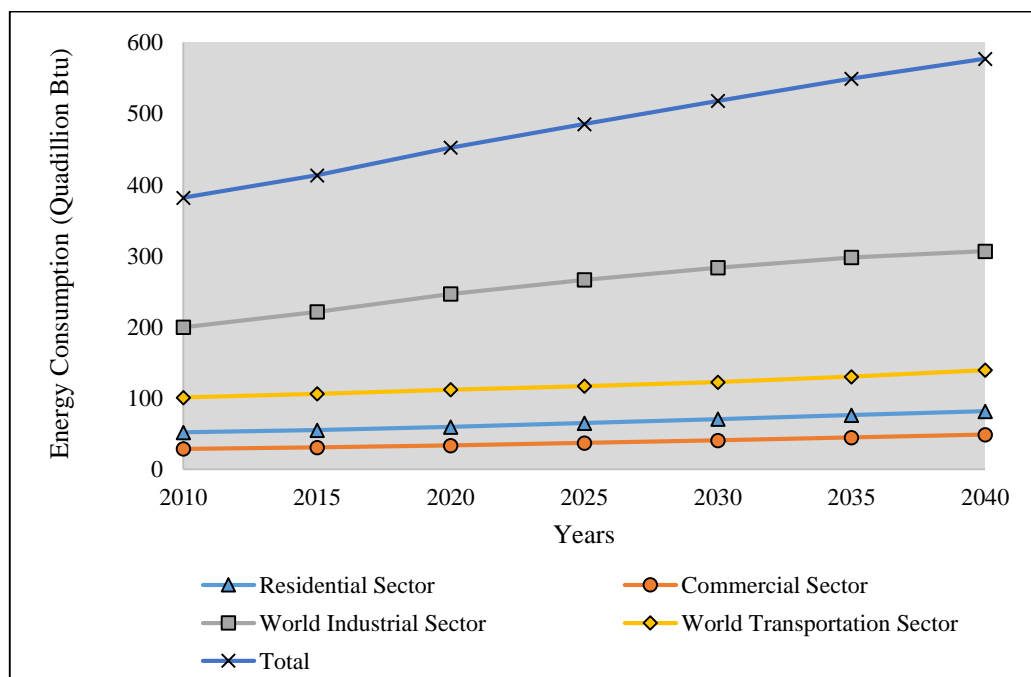

Figure 1.1 Current and future energy consumption by various sectors [2]

Among various bio-based resources, second generation lignocellulosic biomass is considered to be a practical and viable source of energy as it offers no food competition, GHG emissions reduction [12] (sensitive towards the type of biomass and the subsequent assumptions made for the LCA studies [7, 13]) and diverse choice of

feedstock. The types of second generation biomass that can be used for the production of energy and transportation fuel is comprised of woody plants, agricultural wastes, herbaceous plants, aquatic plants, dedicated energy crops and animal wastes [10, 14]. Additionally, in certain geographical locations co-firing with coal can be an economically viable option. However, low energy density and recalcitrance offers several logistical and technical challenges in producing biofuel derived from second generation biomass [10, 15, 16]. Hence, the biomass transportation and biofuel production network must be planned, taking into account all the uncertainties to accurately evaluate future viability and corresponding impacts of biorefining processes.

Supply chain logistics of biomass from collection points to the potential biorefinery site and thereafter to the delivery location of the end products plays an important role in determining the economics of a biorefinery. Key parameters of operational planning, such as, biomass harvesting, collection, storage, transportation, preprocessing, biofuel or/and energy production and final product distribution must be considered while selecting a process, feedstock and facility location [17, 18]. Additionally, every possible supply chain configuration must be evaluated to determine an optimum scheme for any given region of interest.

Similarly, decisions regarding selection of an appropriate processing technique must be taken. The conversion technologies for biorefining can be broadly classified as thermochemical, biochemical and hybrid processes. The goal of these processing techniques is to overcome biomass recalcitrance to produce intermediates and final products that can be marketed directly or be used as feedstocks for subsequent processing. The choice of conversion route has a significant impact on the economics, environmental emissions and social aspects, thereby, influencing the long-term viability of the respective conversion route. Figure 1.2 shows a pictorial representation

of the complexity of a supply chain for biorefining to produce transportation fuel. This figure intends to show a minor segment of the intricate scenario. In reality, a supply chain for biofuel production will rely upon several decisions that must be made based on multiple variability and uncertainty in parameters.

Currently, governments around the world are taking initiative in providing monetary support to encourage research and development activities in order to commercialize the production of biofuels. Renewable Fuel Standards (RFS) were developed by United States Environmental Protection Agency (EPA) in collaboration with refiners, biofuel producers and various stakeholders which originally aimed to produce 7.5 billion gallons of renewable fuel by 2012. The RFS program was extended under the Energy Independence and Security Act (EISA) of 2007 which targeted an increase in the production of renewable transportation fuel from 9 billion gallons in 2008 to 36 billion gallons by 2022 [19]. Also, in 2012 more than 1 billion US dollars were invested by the US Department of Energy in order to develop integrated biorefinery projects; major emphasis being on cellulosic and hydrocarbon fuel projects [20]. The European Union (EU) had set mandates and targets to encourage the production of renewable energy. A 20-20-20 target was set by EU in 2007 which aimed at increasing the share of renewable energy by 20%, enhancing the energy efficiency by 20% and reducing the GHG emissions by 20%. Also, the European Commission (EC) had invested 1.2 billion euros in multiple innovative projects for producing advanced biofuels via thermochemical and biochemical processes [20]. In order to justify the heightened projections and validate various biorefining processes a framework is required that can estimate the long term economic, environmental and societal impacts of existing and emerging processes.

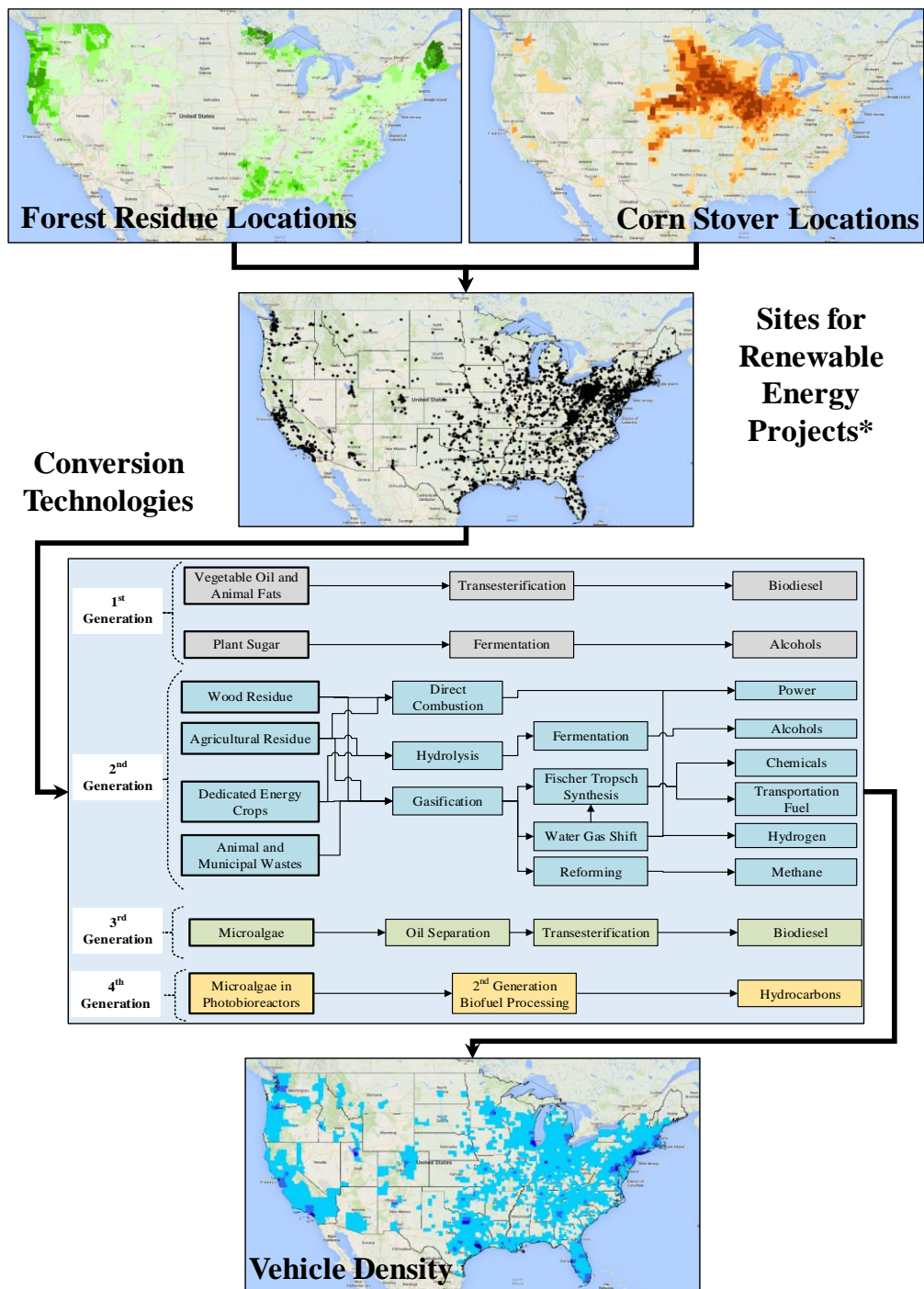

Figure 1.2 Complex supply chain of a biorefinery from feed source to end users

Note: Maps are plotted using NREL's biofuels atlas (NREL 2012). \*The sites are determined by EPA as a part of an initiative to identify contaminated locations that can serve as sites for potential renewable energy projects. Several other criteria's must be satisfied before selecting a site for biorefining.

While all the previously mentioned initiatives will be a great encouragement for investors, policy makers, suppliers, growers and other beneficiaries, we still lack a realistic model that can quantify these region specific impacts of a potential biorefinery. Hence, we need a framework that can be used by various stakeholders to assist in the decision making process in their respective domains. The developed framework should be informative and also be useful for testing potential hypothetical scenarios to mitigate undesirable outcomes. This dissertation research will develop a techno-economic framework that can be used as a decision support tool by stakeholders to test the viability of existing and emerging biorefining processes. By virtue of this contribution multidisciplinary decision support tool is developed that guides stakeholders to meet the targets set by EISA in developing biofuels from lignocellulosic bio-based feedstock. In addition, the developed multidisciplinary framework can be used by various stakeholders such as investors, policy makers, environmentalists and growers to determine concerning impacts of biorefineries based on lignocellulosic and waste biomass.

## **1.2 Research Contributions**

In the last decade, there have been several efforts to develop decision support frameworks in order to determine the long-term economic, environmental and social impacts of a biorefinery, such as, net profit, emissions and jobs created, respectively. The goal of this research is to develop a techno-economic framework that combines process simulation and supply chain optimization in order to determine the optimal biorefinery configuration while capturing realistic aspects of the conversion processes. The following points describe the technical contributions and the novel applications that have been achieved as an outcome of this research. Each of the following points will be elaborated with sufficient examples in the subsequent chapters:

- The novel techno-economic framework developed provides a unique linking of process simulation [21] and supply chain optimization models [22], that can be used to determine the optimum configuration of various biorefining processes. A comprehensive description of the model development and corresponding results are documented in Chapter 4, 6 and 7, respectively.
- The developed model results in a novel approach by linking multiple stand-alone simulation and optimization models in an iterative manner to determine optimum operating capacity for various conversion techniques. The described approach is anticipated to be extremely effective as it would, in contrast to contemporary work, provide greater control over process parameters.
- The framework can be used by stakeholders to test various suppositional schemes for the application of producing renewable energy. Chapter 8 would show the application of the framework to a hypothetical case study as a proof of concept. Another application is presented in Chapter 8 that illustrates how this model can be used by experimentalists to further validate the practical applicability of their research outcomes.
- The flexible nature of the framework allows users to test various combinations of feed and conversion technologies with minor changes in the modeling formulation. Chapter 6 and 7 presents applications of the framework to thermochemical and biochemical processes that further fortifies the claim.

The developed framework does not intend to justify any particular conversion process nor does it aim to advocate the potential for a biorefining in any particular region. Instead, the model intends to answer critical questions, such as:

- Can biorefining in any given region be profitable?
- What feeds or process configurations will be economically viable?



- What would be the configuration of an economically optimum supply chain?
- What are the most sensitive parameters in determining the cash flow?
- What decisions should be taken while planning a biorefinery to mitigate future loss?

The merit of this framework lies in its generalizability to incorporate various biorefining processes and validating its application to diverse geographical locations. The formulated decision support model is not a Life Cycle Assessment (LCA) tool but it can provide critical logistic and operational details to various LCA frameworks. The boundaries of this contribution lies in capturing the economic impacts of various stages of biorefining, starting from the collection and transportation of biomass followed by the production of biofuels and finally the distribution of end products.

## 2. Background and Gaps in Current State of Knowledge

The word “sustainability” has many definitions depending on the context of use. One of the broadly accepted definitions being:

*“A sustainable development is the development that meets the need of the present without compromising the ability of future generations to meet their own needs.”* [23, 24].

In order to validate sustainability of integrated biorefining techniques, it is necessary to estimate future economic, environmental and societal outcomes while planning for its operations [25, 26]. Likewise, if a process has to be sustainable over time, the production scheme and related impacts must be foreseen during the initial stages. Also, it is critical to capture the contradictory objectives, possible production choices and corresponding supply, conversion and market uncertainties [27]. The research to be presented in this dissertation aims to explore the synergies between chemical engineering and sustainability to develop a unique framework that can optimize processes based on economic objectives. The following sections will summarize detailed contributions made to estimates of various aspects of sustainability.

### 2.1 Biorefining

Until the last few decades, biorefining did not receive significant attention, even though it has been practiced for hundreds of years. Previously, there have been unique examples of operating biorefineries [28], but due to the realistic advantages possessed by fossil based fuels, it did not receive sufficient attention to be envisioned in a large scale. Presently, the need for renewable resources has led to the exploration of biorefining possibilities. Biomass is a unique feedstock that has the potential to partially transform the existing fossil dominated energy sector [29]. Adding to this, the capability

of converting a wide range of products using a broad choice of feedstock makes biomass an ideal resource to research for its viability.

### **2.1.1 Feedstock for Biorefining**

Selection of processes for producing biofuels is mainly based on the type and composition of the biomass available. The feedstock for biorefining can be broadly classified into the following four categories:

- First generation biomass: First generation biomass mainly consists of oil and starches from food crops [29, 30]. Currently, most commercial biorefineries use first generation biomass as a feedstock. However, there are a few critical disadvantages associated with this practice, such as, limited availability and food competition which makes it an undesirable feedstock for large scale production of biofuels in the future.
- Second generation biomass: These bio-based feedstocks mainly consists of lignocellulosic plants and waste biomass. Lignocellulosic biomass mainly consists of lignin, cellulose and hemicellulose, which must be broken down into smaller compounds by various conversion techniques to produce biofuels. Lignin is a polymer of aromatic alcohols, whereas, cellulose and hemicellulose are polymers of carbohydrates. The composition of these polymers vary from one biomass source to another; changing the process configurations and feasible product slates [10, 31]. Second generation feedstock is considered to be advantageous compared to first generation as it can be used to produce a wide range of products and doesn't compete with the food supply [29, 30]. As mentioned previously, second generation biomass encompasses an extensive range of feedstocks that further substantiates its potential usage as a renewable resource. The major disadvantage with these are the

low energy density and robust structure which creates transportation and conversion problems.

- Third generation biomass: Third generation biomass mainly consists of algae as feedstock. The micro algae can be used to produce oils and hence has a major disadvantage of high water consumption [30, 32].
- Fourth generation biomass: Fourth generation biomass like the third utilizes algae as a feedstock. However, the former is based on metabolic engineering to produce biofuels [32]. While fourth generation biomass offers advantages, such as, less processing steps, most of the projects are in research stage and has a disadvantage, such as, higher capital cost compared to third generation biomass [33].

Comparing all the previously mentioned biorefining processes, based on the current technological advances, it is evident that second generation biomass is the most promising and appropriate feedstock to be applied for the long-term production of biofuels and energy. Adding to the advantages, second generation biomass can also be co-fired with coal, making it partly adaptable to an existing coal based infrastructure.

### **2.1.2 Conversion Processes**

The ability to convert biomass to multiple marketable products makes it the heart of the field to product supply chain. For years, biomass has been used as a source of energy for heating purposes and energy for the human body in the form of food. Later on, fossil fuels (derived from biomass) were discovered, which were higher in energy content and used to meet the escalating energy needs of the society. The progress in technology led to the use of these fossil and other bio-based resources to be converted into fuel and chemicals which has been used to meet the energy needs of our day to day lives. One of the major challenges with biorefining is to produce fuels and chemicals that can compete with existing products derived from fossil-based resources on an

economic basis, making it a very competitive area of research. The biomass to biofuel conversion processes can be principally classified into three categories:

- Thermochemical process: These processes use heat as one of the major inputs to convert the large molecules present in biomass into smaller usable forms of hydrocarbons and chemicals. The two commonly used thermochemical processes are gasification and pyrolysis [14]. Gasification is the process in which biomass is broken down into H<sub>2</sub>, CO, CO<sub>2</sub>, CH<sub>4</sub>, tar and ash in the limited presence of steam and oxygen [34]. The synthesis gas produced can be further processed to produce power, liquid biofuels and commercial chemicals [35]. Whereas, in pyrolysis the biomass is heated in the absence of oxygen to produce bio-oil, char and gases [36]. The major advantage of thermochemical process is the possibility of the utilization of a wide range of feedstock and high reaction rates.
- Biochemical process: These processes use micro-organisms to break down lignin, hemicellulose and cellulose to products. Fermentation and anaerobic digestion are the two major biochemical conversion process [14]. Unlike thermochemical, biochemical processes are relatively more feed specific and have lower reaction rates.
- Hybrid process: This conversion technique makes use of both thermochemical and biochemical process in succession to produce various products. A study performed by Brown (2007) described two hybrid processes: fast pyrolysis followed by hydrolysis and gasification followed by fermentation [37].

Figure 2.1 illustrates a summary of biorefining pathways based on various bio-based feedstocks. In addition to the previously mentioned conversion techniques, mechanical and chemical operations are also used in succession with these processes to further assist in the breaking down of biomass.

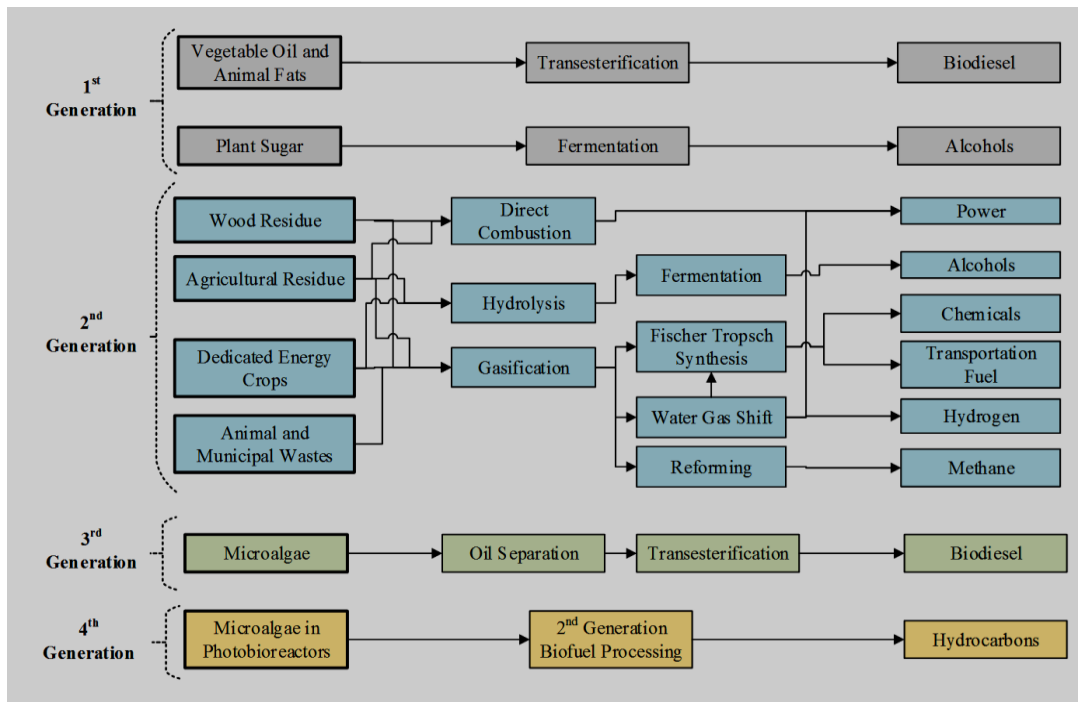

Figure 2.1 Biorefining pathways for various potential bio-based feedstock

## 2.2 Challenges in Biorefining

For ages humanity has been presented with challenges and in most cases has overcome those to pave a way to address it according to necessity. Conceptually, biorefining is an attractive conversion technique, provided, researchers find a way to produce biofuels in a sustainable manner. In comparison to fossil fuels, the difference in the nature of biomass feedstock introduces multiple intrinsic challenges, such as, estimating variable transportation cost [38], further justifying the need for an integrated supply chain optimization and conversion framework .

### 2.2.1 Logistics

The low energy density of biomass makes optimization of the transportation network a necessity [17, 39, 40]. Determining the optimum configuration of a biorefinery enables accurate estimation of the associated costs over time [41], further

rationalizing the need for supply chain optimization. The cost and quality of biomass derived at the processing facility is mainly dependent on the following [42, 43]:

- Feedstock production
- Harvest
- Storage
- Preprocessing (if applicable)
- Transportation

Previously, there have been several contributions that have captured the impacts of biorefining from a supply chain perspective (discussed in detail in section 2.3). Adding to the above work, significant research has been carried out for planning and locating potential biorefinery sites [21, 22, 44, 45]. Uncertainties due to market demand, feed supply and weather makes the planning of the biorefinery configuration a challenge. Yet, the majority of the contributions have not accounted for these factors. However, there have been a few research studies [46-49] which have accounted for some of these uncertainties. This dissertation will demonstrate a unique linking of the process and supply chain optimization models, capturing the impact of many prevailing uncertainties.

### **2.2.2 Conversion**

As discussed in section 2.1.2, both thermochemical and biochemical conversion processes must be supplied with raw materials, adequate energy, chemicals and catalysts/enzymes to break the robust molecular structure of the biomass and its derivatives. Biomass recalcitrance is a major factor that makes the conversion of lignocellulosic biomass more challenging compared with first generation ones.

Amongst many, the following are the major challenges that must be overcome in order to improve the biochemical conversion processes [15, 16]:

- Slow kinetics of the conversion of cellulose to fermentable sugar and low sugar yield from plant polysaccharides.
- Breaking down lignin to expose cellulose.
- Removal of inhibitors that naturally exist or are formed during the process.

These challenges can be addressed by improving pretreatment techniques and/or discovering enzymes that can show improved efficiency in breaking down lignocellulosic biomass. Also, as biorefineries have high utility consumption, integrating and minimizing the usage of raw materials and utilities is another critical challenge. Floudas *et al.* (2012) and Yue *et al.* (2014) have compiled a collection of contributions in addressing the key challenges for various biorefining processes [40, 50].

In summary, there are multiple venues where research can be performed in order to improve various processes of biorefining. One of the major challenges is to provide a scale where these existing and emerging conversion processes can be compared. It is necessary to have a framework in place that can evaluate the sustainability of biorefinery in any given region of interest. The following section will show detailed contributions published so far in the field of Process Systems Engineering (PSE) to develop models in order to estimate the impacts of various biorefining processes.

### **2.3 Current State of Knowledge**

The broad influence of PSE envelops the entire phases of the life cycle of product development. While challenges exist [51], in the past, PSE concepts have been effectively used in various fields, such as, petroleum refining, pharmaceuticals,



chemicals, biochemical production. Several research works have been published in this field that contributes to estimate the impact of biorefining processes, such as, economic viability, emissions and jobs created. The idea behind development of decision support tools is to guide stakeholders in planning long-term sustainable operations for biorefining processes. The overall impact of the supply chain depends on the cumulative effect of each stage. Several research works have been performed to capture multiple stages involved in the entire biomass to biofuel supply chain, such as, feed production, storage, transportation, conversion and product distribution. Like any other supply chain, in order to make decisions regarding investments and strategies, biorefinery must also account for various challenges pertaining to process design, control, operations, modelling and logistics [52]. Currently, the focus is not just to account for the economic viability but also related environmental and societal impacts must be estimated [25, 53]. The following sections will elaborate on the research contributions of various groups in this field of engineering.

### **2.3.1 Techno-Economic Models**

Techno-economic analysis is an approach that is used by business entities to steer their investments. It is an economic evaluation tool that takes into account technical aspects, such as, multiple conversion processes, corresponding conversion yields, feed and thermodynamic properties, as well as constraints, such as, varying feed availability, fluctuating product demand, reaction kinetics and thermodynamics. Being a fledgling area of research, various techno-economic modelling for biorefining has been proposed in the last decade. The major contributions being from the National Renewable Energy Laborites (NREL) [54] which accounts for detailed preprocessing, saccharification, fermentation and product purification steps. The approach presented by NREL is an in-depth evaluation of operating and capital costs involved in the

conversion of lignocellulosic ethanol from corn stover. The original work was further modified in their latest report [55] with a few operational changes. The research was further carried on to perform a techno-economic comparison [56] of various preprocessing techniques. The effect of multiple sensitive parameters, such as, enzyme and corn stover (feedstock) costs were analyzed. Another contribution examined the conversion of corn stover to bio-oils followed by upgrading to naphtha and diesel range hydrocarbons [57]. Two scenarios for on-site production and purchasing of merchant hydrogen were compared in the work. For the same capacity of biomass, a techno-economic analysis was presented that studied two bio-oil upgrading pathways [58]. Hydro-treating was analyzed for hydrogen, marketed by merchant and produced from natural gas. The study determined that the product yield and feedstock cost will have a major impact on the internal rate of return. While these contributions accounted for detailed conversion parameters, the models were not appraised for their corresponding upstream and downstream transportation logistics.

Gnansounou and Dauriat (2010) presented an analysis on the production of ethanol, showing significant contribution of the feedstock on the overall economics and emphasized the pragmatic use of available resources. The research further found that practices, such as, target costing and value engineering [59] must be applied in order to identify the optimum operating configuration. Feedstock costs were determined to be the parameter that had the most impact on the economics of the lignocellulosic biorefinery. Similarly, a previously published review article [60] concluded that the feedstock cost is the most important parameter that determines the economics of a process. Contemporary research [61] demonstrated a techno-economic model for the production of liquid fuel and electricity from agricultural residue, by applying the process of gasification. The analysis aimed to compare the impacts of low and high

temperature gasification on the operating and capital costs. Capital and feedstock costs were observed to be critical parameters in determining the overall economics. Another contribution presented a techno-economic contrasting thermochemical and biochemical conversion techniques for the production of biofuels[62]. Six biomass to biofuel technology schemes were analyzed based on conversion platforms, such as, pyrolysis, gasification and fermentation. In other published research, a study was presented to compare the performance of thermochemical and biochemical conversion processes [63]. The work aimed to enhance the performance of existing sugarcane mills by supplementary production of ethanol from waste bagasse and cane trash. Previously summarized contributions examined detailed conversion configurations and the corresponding parameters. However, these models demonstrated limited details in estimating the optimal supply chain logistics, the impact of which would be reflected on the feed cost (determined as a sensitive parameter).

In summary, most of the currently available techno-economic models developed have taken into consideration multiple variables in the process as well as performed analysis on several biomass feedstock. While various factors determine the economic performance of an operating biorefinery, almost every model studied so far has observed that the feedstock cost is the most critical parameter effecting the profitability. Subsequently, many research groups are focusing towards developing supply chain models to determine the optimum operating configuration of a biorefinery. This consists of planning feedstock resources, transportation network, biorefinery location, conversion processes (including preprocessing) and distribution network. Hence, the techno-economic model for biorefining processes must include detailed product and feedstock transportation logistics. Stakeholders must be careful of the fact that due to the low energy density of biomass, any wrong decision in the long-term planning of

transportation logistics may lead to acute negative impact on the economics. The following section will summarize the contributions in planning the supply chain for the production of biofuels, bioenergy and bio-based chemicals from various biomass resources.

### **2.3.2 Supply Chain Planning Models**

Previously, several contributions have been presented that focused on determining the optimum supply chain configuration for planning and operating a potential biorefining facility. Tittmann *et al.* (2010) presented a broad techno-economic framework that captured critical details of the supply chain, beginning from feed transportation to product delivery, in the process determining the size and locations for biorefineries [64]. A recent contribution [65] demonstrated the development of a Mixed Integer Linear Programming (MILP) optimization model that simultaneously considers supply chain configuration, integration strategy and production planning. The results obtained showed that pre-conversion to a petroleum upgrading pathway is more economical. This framework intended to merge the biofuel supply chain with the existing petroleum ones while capturing the realistic demand and supply uncertainties. Tong *et al.* (2014) developed a multi-period MILP optimization model to design and plan advanced biofuel supply chain [66]. This contribution also aimed to capture the effects of integrating biofuel supply chain with existing petroleum infrastructure. The uncertainties in demand were accounted and incorporated into the framework using fuzzy probabilistic programming.

In other research [67], a Mixed Integer Non-Linear Programming (MINLP) model was developed that determined the optimum configuration of operation and storage of biomass among potential options. Sharma *et al.* (2011) proposed a decision support tool that was based on a MILP model to maximize the stakeholder value [68].

This model comprised of various financial, operational and configuration constraints as well as accounted for waste reduction expenses. An extension of the previous work was presented [69] that stretched the details of the techno-economic model developed. In a recent contribution [70], an iterative framework was formulated that combined optimization (Linear Programming (LP)) and process simulation (Aspen Plus® and MATLAB®) models guiding stakeholders by providing strategic decision support.

A scenario based optimization approach [71] was demonstrated that intended to redesign the operational supply chain for forest biorefineries. Profitability of the process and its robustness for various biorefining options were compared. The study emphasized the importance of the supply chain assessment with fluctuating capacity of the facility. Ekşioğlu *et al.* (2009) introduced a mathematical model [72] that provided a variety of logistical results for future biorefineries; demonstrating its applicability in the Mississippi region. Recent work [73] has proposed a MILP framework that can be used to design bio-based resources to energy networks. This claim was supported by a case study to produce biogas from waste biomass.

The frameworks reviewed previously focused on providing decision support while accounting for the parameters pertaining to the supply chain and planning. However, the models examined so far presented a few conversion options and therefore, had a limited scope for the inclusion of details related to the conversion process. This dissertation has proposed a generalizable framework that can be merged with multiple conversion options to evaluate the corresponding economic feasibility. The next section will summarize the essence of works performed so far in selecting the most economic conversion technique.

### 2.3.3 Technology and Product Selection Superstructure

There are numerous existing and emerging conversion options to produce biofuels from various feedstocks. Selecting an appropriate technique among the array of potential ones is a key challenge. In the past, there have been many research contributions that were dedicated to determine the optimum configuration of preprocessing and final conversion processes. Sammons *et al.* (2007) proposed a methodology to find the optimum route and slate of products for biorefineries [74]. The developed mathematical optimization based framework included techno-economic parameters. Another contribution, Kim *et al.* (2013) developed a “technology superstructure” [75] that consisted of various feed, product, byproduct and conversion details. This LP model was used to find the best set of products for an economically viable biorefinery. Another work [76] proposed an approach to determine the optimum configuration based on feedstock available and desired products. A “forward-backward” approach was developed and the overall optimization problem was broken down into multiple sub-problems based on Bellman’s principle.

Zondervan *et al.* (2011) proposed an Mixed Integer Problem (MIP) optimization model that aimed to determine the optimal production scheme for biofuels and chemicals [77]. Baliban *et al.* (2013) demonstrated an optimization framework for biomass and gas-to-liquid conversion process [78, 79]. The model incorporated heat, electricity and water integration, based on which case studies on multiple scenarios were performed. The results led to the conclusion that the studied biorefining processes have the capability of offering competition to crude oil based conversion processes. Previously, Baliban *et al.* (2011) [80] proposed a MINLP optimization process superstructure based on which case studies on coal, biomass and gas-to-liquid processes were performed.

The models developed to optimize the process superstructure is a major contribution to this area of research. However, in recent years, the focus of the research has shifted from estimating the economic impact to determining the most sustainable biorefining option in the long-term.

#### **2.3.4 Multi-Objective Optimization and Optimization under Uncertainty**

This section will focus on the work documented so far, incorporating economic, environmental and societal impacts, to determine the optimal configuration of biorefineries. Subsequently, research contributions on the process and supply chain optimization while accounting for uncertainties will also be presented in this section.

A multi-objective MILP superstructure optimization model was proposed that included economic and environmental criteria [81]. You *et al.* (2012) developed a multi-objective MILP framework that was optimized based on economic (analyzed cost), environmental (LCA) and social (jobs) objectives [82]. Aspen Plus® simulation models were used to provide details regarding conversion and emissions of the processes. Another unique work [83] demonstrated the development of a multi-objective optimization model that accounted for all the major aspects of sustainability. The framework showed how economic, environmental and societal factors can be reckoned to plan supply chains for a biorefinery producing multiple products. To show the working of the developed framework, a case study was performed on the country of Mexico. In another contribution [84], a framework was presented for optimal designing of a sustainable tri-generation system by simultaneously accounting for all the three aspects of sustainability. Giarola *et al.* (2013) proposed a MILP supply chain optimization framework that considered economic and environmental impact while simultaneously accounting for market risks [85]. The results concluded that investors attitude towards risk is a key driver for strategic decisions.

A stochastic optimization framework [86] was developed that captured the effects of conversion and market uncertainties. Also, potential for the reduction of processing costs were determined for the studied scenarios. Sharma *et al.* (2013) presented a supply chain optimization model that accounted for uncertainties due to weather variations [87].

## **2.4 Summary**

Based on the contributions reviewed from the literature, significant gaps in the current state of knowledge were determined. While efforts have been made to link various simulation and optimization models [70, 88], we still lack a framework that can be used by stakeholders to access details regarding biorefining processes and their corresponding supply chains. The combined effect of the transportation logistics and process configuration reflects the future viability of sustainable biorefining. To date, there has not been a detailed framework that links process simulation, supply chain optimization and supply chain simulation models. This document will focus on the development of an adaptable process optimization framework. The model will be linked with supply chain optimization [22] and discrete event simulation [89], resulting in an informative techno-economic and supply chain decision support framework [21, 90]. Chapter 3 will expand on the uniqueness and the novelty of the research while affirming the boundaries of the specific contribution.



### **3. Research Novelty**

#### **3.1 Summary**

Numerous contributions have evolved which are of great importance in determining the distinct impacts for the long-term operations of sustainable biorefineries. Each of the individual contributions described in the Chapter 2 is necessary and has served as a great source of motivation. However, there has been limited work in determining the combined impact of biorefining to estimate economic parameters, while including details from the major stages of the supply chain. As examined previously, discrete contributions have been made in biorefining to determine transportation logistics, process simulation and optimum configuration under uncertainty. The research presented in this dissertation integrates the diverse aspects of the biomass to bio-energy supply chains, such as, transportation network, process optimization, and the corresponding uncertainties under a multidisciplinary framework. Achieving this is a major contribution in the field of PSE. The innovative research presented in this document focuses on the development of process optimization schemes that can communicate with transportation optimization models in an iterative manner to determine the best configuration, based on economic viability. The resulting contribution is part of a unique decision support tool in the area of biorefining that is currently being explored by many contemporary researchers. The following section will outline the boundaries of the research followed by the novel contributions that are achieved by the state of the art model.

#### **3.2 Scope of the Research**

The model developed addresses several voids in the existing state of knowledge. It is important to describe the bounds of this contribution in order to define the scope

of the problem that can be managed by the framework. The developed model is confined to the following assumptions:

- Limits of the supply chain for the purpose of modeling begins with the collection points for raw materials. The collection point is the road location nearest to the field where the biomass is assumed to be gathered after the harvest for transportation by road. These points were determined using Geographic Information System (GIS) tools and data from the literature [22]. The collection point is considered as the source of biomass in the framework. The goal of the transportation optimization model is to identify out an optimum pathway to deliver bio-based feedstocks from the source location to the potential biorefinery location (which will be decided by the model as an output) and distribute the products to the storage depot. These depots are assumed to be locations, determined logically, based on the existing road network, in each of the selected counties. The most accessible point in the county based on the road network is assumed to be the depot location. The downstream limits of the supply chain framework is the delivery of final products to the selected depot locations.
- Conversion processes used in the techno-economic framework, includes both thermochemical and biochemical pathways. The process simulation and optimization models are created based on mass and energy balances. While most of the unit operations and processes are rigorously designed, there are a few exceptions which require customized designing and hence have been left out of the calculation. Also, since the processes are designed using dedicated simulation software (Aspen Plus®, Aspen Energy Analyzer® and Aspen Economic Analyzer®), several inherent constraints have been enforced based on the values obtained from the literature, such as, process parameters, rate of consumption of raw materials,

splitter/mixer fraction, number of stages etc. Also, for critical chemical reactions, the corresponding kinetic data have been supplied and additional ports are provided in the framework to input the user specified kinetics. While the kinetic data can be incorporated in many ways, currently, the data obtained from the literature, based on the experimental data, is used. Chapter 8 will expand on the multiple methods to incorporate these data.

- The cost of feedstocks, raw materials, utilities, chemicals and transportation fuel is obtained from the literature. In reality, these costs are fluctuating and depends upon several business and political factors. Also, the equipment and capital cost for a biorefinery is estimated using in-built data in the Aspen Economic Analyzer®.
- For simplicity, the framework developed assumes a centralized biorefinery facility location. However, other potential configurations cannot be ruled out. Presently, the model accounts for the storage and pre-treatment at the facility location.
- The process optimization model acts as a black box for the entire framework. The changes in process configuration must be embodied to the model, prior to initiation of the iterative procedure.

Within the previously stated boundaries, the techno-economic decision support framework is run iteratively. The model couples process optimization, supply chain optimization and discrete event simulation in such a manner that the iterations result in an optimal capacity of biorefinery. The developed framework is capable of generating and optimizing process data based on potential feedstock in any given region. Moreover, the developed model has several novel features that will be discussed in the next section.

### 3.3 Novel Contributions

The uniqueness of a model is determined by its novelty in the formulation, unparalleled integration, diverse applications and the level of detail it can handle. The model developed in this research embodies all the previously mentioned aspects. While the broader objective of the research is to design a decision support tool, this document will primarily focus on the development of process optimization model which is a critical segment of the overall framework. This is the venue where several existing and emerging conversion details are incorporated. Subsequently, the model is linked to the supply chain optimization and discrete event simulation to create a multi-disciplinary framework for economic optimization of an integrated biorefinery. Following are the distinct novelties of this research contribution:

- **Model formulation:** The framework is formulated in a unique manner that accommodates both simulation and optimization models. The simulation models captures the practical aspects pertaining to the biorefining conversion processes. On the other hand, optimization models are used to ascertain the best configuration based on the imposed constraints. The multidisciplinary tool developed is the result of a unique tailoring of the simulation and optimization models.
- **Multi-disciplinary approach:** Another distinct feature of this model is that it unites various aspects of supply chain management, process engineering and discrete event simulation. This integration is one-of-a-kind that has been achieved in order to guide the stakeholders.
- **Linking of the process simulation:** Previously, there have been many contributions that have addressed the importance of creating a detailed process simulation model. This contribution takes a stride by linking the detailed process simulation model to an optimization framework which is further linked onto the multi-disciplinary

decision support tool. An iterative methodology is suggested, along with the linking, to determine the optimal biorefinery configuration for any given region of interest.

- **Versatile applications:** The framework rests on the fundamental concept of developing multiple detailed process simulation models, which can be run separately, to test various scenarios. Eventually, the output obtained can be compared to determine the most economically viable option. The case studies to be described in the upcoming sections would be used to further fortify these claims.
- **Generalizability:** One of the major assets of the model is the competence to be applied to various regions to evaluate the viability of biorefining. Another key contribution of the work is the capacity of the framework, to include probable bio-resources available in the region, guiding the growers by checking the potential outcomes pertaining to the economics of the biorefinery.
- **High resolution:** The level of detail that the developed model can incorporate is extensive and hence the resolution of the results obtained is relatively higher compared to the previous contributions [71, 72, 75]. From a process point of view, the model can adapt to details, such as, kinetics, process constraints and thermodynamic data, which otherwise is a challenge to include. Whereas, from a supply chain perspective, the details based on real road network and potential biorefinery location can be incorporated. Subsequent chapters will demonstrate the inclusion of discrete event simulation modeling [89] to the framework, further enhancing the economic estimation by accounting for uncertainty.

Supplementing to all the previously mentioned details, the developed framework can also calculate the process emissions that can be utilized by the existing LCA or environmental impact assessment tools [91, 92]. The model does not address

the specifics regarding social impacts, such as, jobs created but the obtained results can be interfaced to the existing societal impact indicators [93]. Nevertheless, the framework integrates several aspects of the conversion process and transportation involved in the supply chain for the production of biofuels.

The developed model can be used by investors to foresee the economic viability of potential projects, thereby making cognizant decisions pertaining to investment. Also, policymakers can utilize this model to make judgment towards future incentives with the motive to support a marginal processes (in terms of economic feasibility) to inspire stakeholders. Additionally, environmentalists can use the developed decision support tool to compare the emissions generated by various biorefining processes and hence impose appropriate taxes based on the effluents (GHG emissions, ash etc.). Furthermore, this framework can be used by growers to make insightful judgment on planning future cultivation. The stakeholders involved in various stages of the supply chain of biorefining can use this versatile tool to make decisions. While this research is inspired by previous contributions in developing process simulation [54, 55] and supply chain optimization models (MILP, MINLP, LP etc.) [74, 75, 78], this dissertation will unite these critical aspects. The resulting model will not only act as a decision support tool but will also serve as an motivation, to link various simulation and optimization tools, to produce diverse results for stakeholders. The next chapter will sequentially demonstrate the way in which various individual models are unified resulting in a multidisciplinary decision support tool.

## **4. Development of the Techno-Economic Framework**

One of the major traits of a techno-economic model is its applicability as a guide for stakeholders to evaluate probable economic outcomes. This chapter will expand on the development of an informative framework that will unify fundamental concepts from multiple disciplines of sciences and engineering. Contents of this chapter have been drawn from *Clean Technologies and Environmental Policy*, Volume 16, Issue 6, S. Sukumara, W. Faulkner, J. Amundson, F. Badurdeen and J. Seay, “A multidisciplinary decision support tool for evaluating multiple biorefinery conversion technologies and supply chain performance”, 2013, pages 1027-1044, with kind permission of Springer Science and Business Media.

### **4.1 Motivation**

In order to evaluate the sustainability of biorefining processes, a framework is required that can quantify impacts, such as, economic feasibility, environmental emissions and social impacts [25, 94]. Ideally, a decision support framework must not only impart details but also be capable of being interfaced with the existing assessment tools of sustainability. Developing such an adaptable computational model requires insightful merging of multiple disciplines of science and engineering towards a common goal. As described in Chapter 2, there have been several research which have partially contributed towards the development of a framework. The versatile framework to be discussed in this dissertation creates a decision support tool that can be used by stakeholders, such as, policymakers, investors, growers, environmentalists, distributors, experimentalists, etc. In a broader context, this is a complex problem to be solved, hence an effort in solving is a much needed contribution. However, solving such an intricate problem requires decomposing the problem into simpler modules. Discrete solving of the individual divisions is a rational, systematic and credible approach.

Furthermore, the approach requires a unique iterative linking of the comprehensive models which can share the needed parameters.

The model that has been developed in this research is a combination of three exhaustive models, namely process optimization, supply chain optimization and discrete event simulation. This dissertation focuses on the development of process optimization model, while using the other two previously documented models [22, 89] to perform case studies.

## **4.2 Process Optimization Model**

Conversion process is a critical facet of the overall supply chain for converting biomass to marketable products [95, 96]. In most cases, the selection of a conversion technology is contingent on the demand for products [97]. However, for biorefining, due to high recalcitrance and low energy density, the energy utilized, raw materials procured and time consumed in the production process emerge as critical factors. In order to account for these aspects, process simulation models must be created. Developing such models not only helps capture practical details of the conversion technique, but also improves the replication of the original conversion scenarios. To initiate the development of the process optimization model, the first step is to identify the most promising conversion technique to be developed based on the availability of feedstock and product demand in the given region of interest.

### **4.2.1 Feedstock Availability and Product Demand Assessment**

Selection of the feedstock is a critical decision that can impact the long-term operation of a potential biorefinery [98]. Presently, in the USA, most of the biofuels produced use first generation biomass as a feedstock [99]. In the future, exploring the prospects of replacing first generation biomass with lignocellulosic (second generation) feedstocks will be desirable, as the later offers several advantages over the former



(discussed in section 2.1.1). Currently, several bio-based feedstock, such as, forest residue, urban wood residue, agricultural waste and animal waste have been recognized as potential feedstocks for biorefining [100-102]. While plenty of data are available for the previously mentioned bio-based feedstocks, it is essential to locate it on a real-time map. Subsequently, this process may require accessing spatial data obtained from GIS and literature. The statistics obtained must be converted into an array which can be used as an input to the framework by decomposing the data into state and county wise availability. To increase the level of detail, spatial data must be plotted with respect to the current road network, further enhancing the credibility of the results obtained from the model. The case studies described in Chapter 6, 7 and 8 will show applications of the described approach to existing and hypothetical scenarios.

The potential availability of biomass may be excessive in some regions; hence, it is logical to limit the model such that the production does not exceed the demand. Therefore, constraining the products requires calculating the demand for all the potential commodities that can be produced, using all the major bio-based feedstock available in the locale [103]. Since, the model developed currently focuses on the utilization of lignocellulosic biomass via thermochemical and biochemical conversion processes, the regional demand for products, such as, liquid hydrocarbons, electricity and alcohols is calculated. A previous contribution [22] has determined the demand based on consumption of various products, such as, gasoline, diesel, natural gas, heavy residual oils and ethanol in the region of interest. The same is used by the proposed framework to perform advanced case studies in the locale. This research utilizes the fact that the demand of any product entity is subjected to high fluctuation and is dependent on multiple parameters [104]. Currently, the model does not account for the stochastic nature of feedstock available and the product demand. Nevertheless, the

contribution will show the applicability of the model for any given upstream and downstream inputs.

#### **4.2.2 Process Simulation Development**

From the pathways shown in Figure 2.1, one or more of the conversion schemes are selected based on the availability and demand in the region. Currently, the pathways show limited number of biorefining conversion processes. In the future, more pathways will be added as technologies advance. Hence, it is essential to develop multiple process simulation models that can serve as an accessible library to the overall framework. The vision of this research is to populate the framework with all the major processing techniques. This would consume a lot of time and require regular maintenance, as improved technologies emerge. The present research will demonstrate the working of the model by performing studies with thermochemical and biochemical processes which will be developed and finally be tested for its applicability.

##### **4.2.2.1 Biomass Gasification (Thermochemical Process)**

The feasibility of the gasification process has been widely explored and there are many instances where these are used in industries to produce synthesis gas [105]. However, the application of gasification using cellulosic biomass is still one of the active areas of research. While there are a few examples of biomass in co-fired gasifiers [105, 106], its viability in a wide range of regions is still not established [106]. Also, due to the fact that gasification can use wide range of feedstocks, such as, coal, forest residue, crop residue, dedicated energy crops and municipal waste [107], it will be informative to determine the optimum blend of these feedstocks in the long run [103]. To address such key issues, simulation models are required that can incorporate multiple feedstocks to produce a wide range of marketable products. In this research,

gasification of biomass followed by Water Gas Shift (WGS) and Fischer Tropsch Synthesis (FTS) reaction is simulated to produce power and liquid hydrocarbons.

Aspen Plus® is a versatile tool that is used widely in the process industry worldwide [108]. Steady state simulations developed in Aspen Plus® has great potential for interfacing through this Aspen Engineering Suite which is a common platform for exploring useful options, such a heat integration, capital cost estimation, dynamic simulation etc. Such qualities makes Aspen Plus® an appropriate tool to develop process simulations for biorefining. Adding to the positive attributes, the addition of a dedicated Microsoft Excel® interface makes it easier to link the model with multiple optimization and simulation tools. While there are concerns with the limited applicability of this tool to simulate biochemical reactions, various alterative channels have been explored to circumvent this issue [54, 55].

One of the major challenges in creating simulations for biorefining processes is to incorporate the raw material data in an acceptable format for the software. In this work, the feedstock is distinguished based on proximate and ultimate analysis data. Data for various biomass sources are taken from literature [57, 109, 110]. In order to improve economic performance [106, 111], provisions are made to include coal [112] to the simulation along with biomass, such as, forest residue, agricultural residue, dedicated energy crops and animal waste. The proximate and ultimate analysis data of the biomass used in the simulation are tabulated in Table 4.1 and 4.2, respectively.

Significant savings may be achieved by a two stage facility, where biomass from the field is transported to a pre-treatment center, where the biomass is densified, followed by transportation of the pre-treated feed to the biorefinery site. For the initial assessment, the biorefinery is assumed to be located centrally and pre-treatment operations are assumed to be performed at the biorefinery location.

Table 4.1 Feed proximate analysis data obtained from various sources

	<b>Fixed Carbon</b>	<b>Volatile Matter</b>	<b>Ash</b>	<b>Moisture</b>	<b>Source of data</b>
<b>Forest Residue</b>	6.96	42.10	2.03	48.91	[110]
<b>Chicken Litter</b>	1.70	38.90	16.40	43.00	[109]
<b>Corn Stover</b>	17.70	52.80	4.50	25.00	[57]
<b>Switchgrass</b>	12.93	69.14	8.09	9.84	[110]

Table 4.2 Feed ultimate analysis data

	<b>Carbon</b>	<b>Hydrogen</b>	<b>Oxygen</b>	<b>Nitrogen</b>	<b>Sulfur</b>	<b>Chlorine</b>	<b>Ash</b>
<b>Forest Residue</b>	25.70	2.35	20.40	0.53	0.06	0.00	2.03
<b>Chicken Litter (Dry Basis)</b>	28.17	3.64	34.43	3.78	0.55	0.63	28.80
<b>Corn Stover (Dry Basis)</b>	47.28	5.06	40.63	0.80	0.22	0.00	6.01
<b>Switchgrass</b>	42.09	5.25	33.87	0.69	0.17	0.00	8.09

The main purpose of the model is to demonstrate an effective methodology by which the process and transportation models can interact to generate critical details. Consecutively, distinct processes, pre-treatments and distribution schemes can be studied using this framework. The process simulation model contains detailed information regarding conventional chemical species. Unlike the conventional chemicals, biomass has a varying composition depending on the geographic region of its origin and type [14, 113, 114]. Therefore, the feedstock is classified as a “non-conventional” species in the simulation. Once specified, this feed can be changed into conventional elemental category by translating the proximate and ultimate analysis data. For this, FORTRAN code is compiled that calculates the elemental composition

automatically in each iteration. Figure 4.1 illustrates the compiled FORTRAN code used for this purpose.

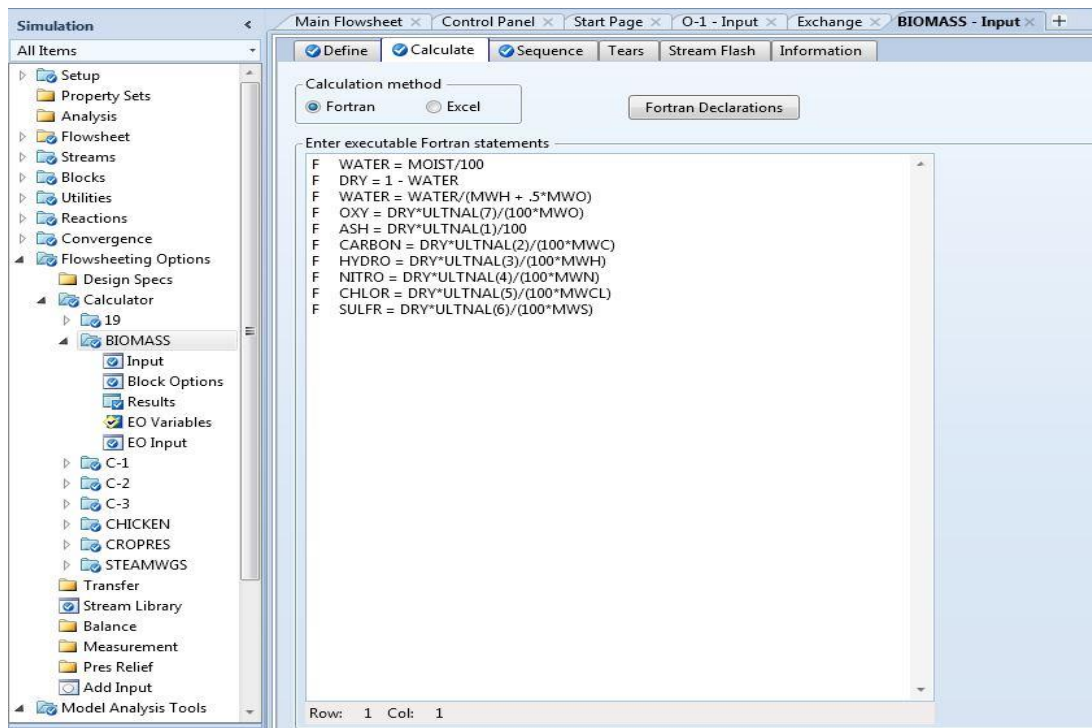

Figure 4.1 The FORTRAN code in the calculator window (Aspen Plus®) to convert the “non-conventional” feed to “conventional” composition

This is an alternative approach to automatically calculate the elemental composition. Both RYield (yield reactor) and RStoic (stoichiometric reactor) [108] are built-in reactor models available in Aspen Plus® that can be used for this application. For the case studies to be performed, the stoichiometric reactor is used as it can accommodate additional heat input/output details. The previously described code is compiled to calculate and assign the stoichiometric coefficients required for the RStoic model. The output from the reactor is the stream containing the calculated elemental components and the ash present in the biomass. Currently, the ash is not analyzed for inherent elements and compounds. In the future, the ash analysis will be critical as it

may result in the formation of impurities, such as, CaO, SiO<sub>2</sub>, Al<sub>2</sub>O<sub>3</sub>, Fe<sub>2</sub>O<sub>3</sub>, Na<sub>2</sub>O, etc. [115], in the gasifier.

The gasifier is simulated using the Gibbs reactor (RGibbs), the output of which is constrained by specifying potential products [116-119]. Calculator functions are also assigned to the input to calculate the steam and air flow rate requirements for the reactor. While the exothermic reactions takes place, the temperature in the reactor must be controlled by varying the air and steam flow rates. Furthermore, the temperature at which the reactor operates governs the material and design parameters. This aspect of gasification has not been explored yet, however, the reactor is restricted to a temperature ranging from 800°C – 1500°C [117, 120]. Previously, there have been valuable contributions [121-123] which have emphasized on developing the process simulation model using coal and biomass as feedstocks. Presently, this section of the simulation is designed to estimate the possible products and is not concerned with the equipment design aspects. Based on the runs performed, products formed in the gasifier consist of CO, H<sub>2</sub>, CO<sub>2</sub>, CH<sub>4</sub>, H<sub>2</sub>S and ash, which is consistent with the literature [116, 124]. Also, it is assumed that ash will be removed and collected based on the density difference. However, in reality the removal of ash is accounted as a challenge in some cases [124]. Furthermore, depending on the composition of the ash collected, effluent treatment process may be required. Table 4.3 shows the major reactions involved in the gasification process.

Once the solids present in the outlet of the reactor are separated, the hot synthesis gas must be cooled to 26°C in order to prepare for the H<sub>2</sub>S separation columns. Hence, the heat from the stream must be trapped, so that it can then be utilized as a source of energy. This recovered energy stream can be used to heat various process streams, thereby saving external utilities required by the process. Figure 4.2 portrays a

snapshot of the process flow diagram (PFD) in Aspen Plus®. The presence of H<sub>2</sub>S possess serious catalyst poisoning challenges to the subsequent downstream processes and hence must be removed [125].

Table 4.3 Reactions occurring in the gasifier. Adapted from the previous contribution, Sutton *et al.* (2001) [119]

Reactions	Nature of reaction
$C + 0.5 O_2 \longrightarrow CO$	Exothermic
$CO + 0.5 O_2 \longrightarrow CO_2$	Exothermic
$H_2 + 0.5 O_2 \longleftarrow H_2O$	Exothermic
$C + H_2O \longleftarrow CO + H_2$	Endothermic
$C + CO_2 \longleftarrow 2CO$	Endothermic
$C + 2H_2 \longleftarrow CH_4$	Exothermic
$CO + 3H_2 \longleftarrow CH_4 + H_2O$	Exothermic
$CO + H_2O \longleftarrow CO_2 + H_2$	Exothermic
$CO_2 + 4H_2 \longleftarrow CH_4 + 2H_2O$	Exothermic

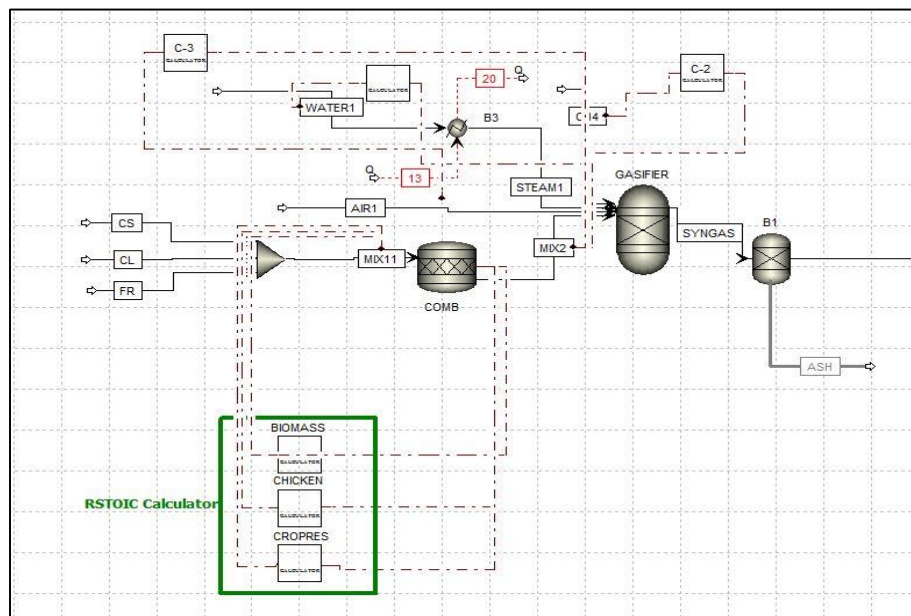

Figure 4.2 Process flow diagram (Aspen Plus®) for the biomass gasification unit

In order to remove the sulfur compounds present in the process stream, various configurations have been recommended in the literature [126-128]. While, all the schemes have their own pros and cons, a choice must be made based on the requirements of the process. A previous simulation based comparison in ProMax® (simulation software) [126] showed that the Rectisol® process (methanol as solvent) has many advantages over other acid gas (CO<sub>2</sub> and H<sub>2</sub>S) removal techniques, such as, Selexol™, Purisol® and Fluor Solvent™. While, other chemical solvents, such as, ethanolamines, are widely used in industry, this simulation will use methanol for removing CO<sub>2</sub> and H<sub>2</sub>S from the synthesis gas. Also, for an integrated biorefinery, methanol is a potential product [129] which further justifies its use for this case. The solvent is cooled to -36°C and the cooled synthesis gas is introduced to the absorption column. Absorption takes place in two columns in series, followed by the recovery of methanol which is recycled. This stage of the overall process is highly energy intensive and requires both cooling and refrigeration utilities. The resulting H<sub>2</sub>S free synthesis gas is sent to the WGS reactor to enhance the H<sub>2</sub>:CO ratio. Figure 4.3 illustrates schematic of the acid gas cleaning section.

The ratio of the synthesis gas produced during the gasification process is approximately 1:1. In order to increase the applicability of the synthesis gas to yield downstream products, such as, methanol, hydrocarbons, hydrogen and power, this ratio must be improved at least to 2:1. To enhance the H<sub>2</sub>:CO ratio of the clean synthesis gas, WGS reaction should be applied. This is an exothermic reaction which takes place in the presence of catalyst. The reaction is carried in the presence of Cu/Zn/Al<sub>2</sub>O<sub>3</sub> catalyst at 245°C [130]. The equation and empirical rate expression used in the simulation is shown in Equation 4.1 and 4.2, respectively.



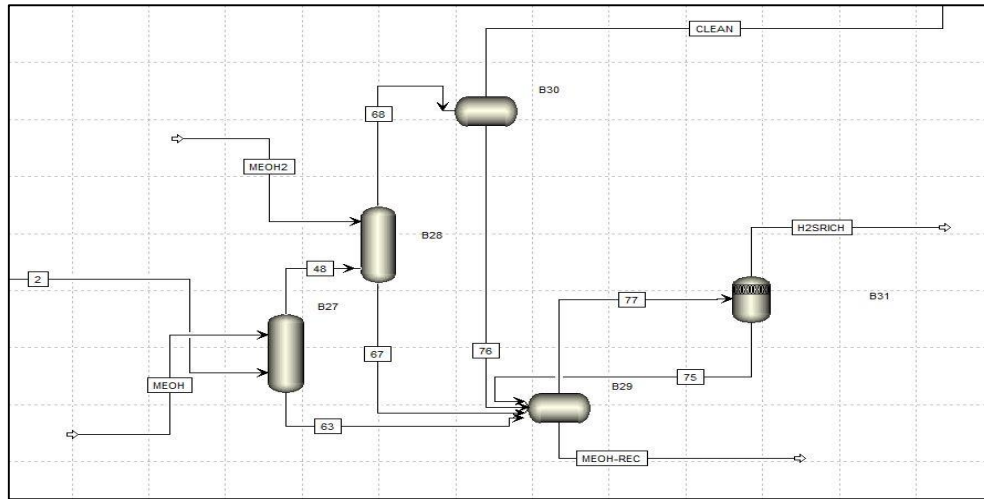

Figure 4.3 Process flow diagram (Aspen Plus®) of H<sub>2</sub>S cleaning section using methanol as a solvent

Water Gas Shift reaction [130]



Rate expression [130]

$$r_{WGS} = k_0 * \exp\left(-\frac{E}{RT}\right) \left(P_{\text{CO}}^n P_{\text{H}_2\text{O}}^m - \beta\right) \quad (4.2)$$

$$\beta = \frac{P_{\text{CO}_2} P_{\text{H}_2}}{P_{\text{CO}} P_{\text{H}_2\text{O}} K_{eq}}$$

Where,  $m$ ,  $n$ ,  $\ln k_0$  and  $E$  values are given for various catalyst configuration.

For this case:

$$m = 1,$$

$$n = 1,$$

$$\ln k_0 = 12.6$$

$$E = 47.4 \text{ KJ/mol}$$

*Note:* These expressions are used from literature. These can be adapted to any selected process chemistry.

In order to calculate the changing steam requirements, a user-specified function is utilized that automatically calculates the flow rate based on varying incoming synthesis gas. The hydrogen rich synthesis gas produced is then cooled to condense the entrained water. Subsequently, the synthesis gas stream is split into two streams. The first one is sent for generating power, which is one of the marketable products from the biorefinery. The second stream is sent to the FTS reactor for the production of hydrocarbons. Figure 4.4 shows the PFD for the WGS reactor. It should be noted that the split fraction of the synthesis gas for generating electricity and liquid transportation is a major decision variable which can be changed based on real demand data in any given region of interest. To start the iterative process the split fraction of liquid transportation fuel is assumed to be 0.85. Hence, 0.15 is the split fraction of synthesis gas for the production of electricity.

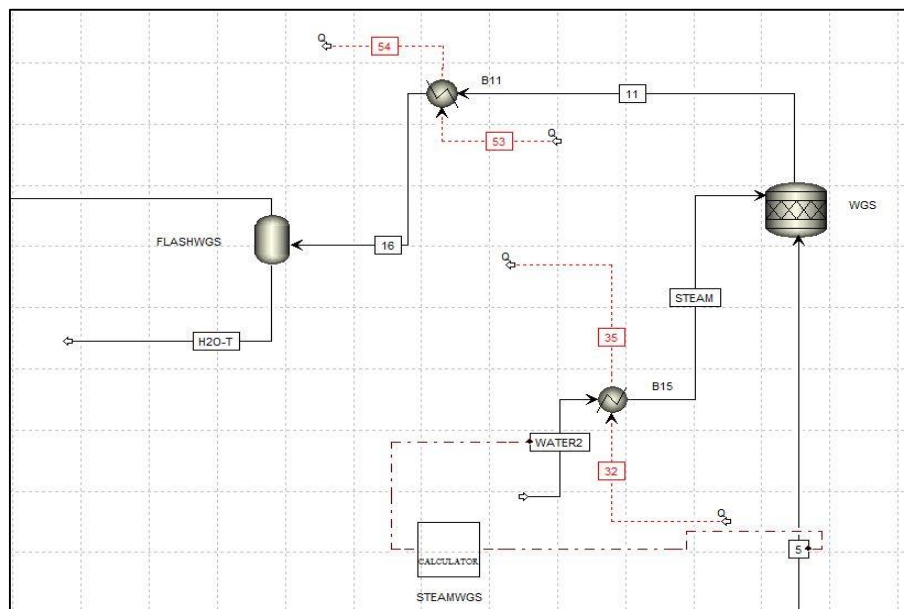

Figure 4.4 Process flow diagram (Aspen Plus®) of Water Gas Shift reactor segment

Currently, due to the high demand for liquid transportation fuel, a major portion of the synthesis gas is channeled to the FTS reactor. FTS is an exothermic reaction that converts the synthesis gas into multiple hydrocarbons, as shown in Equation 4.3.



Where

$n$  = Average carbon chain length

$m$  = Average number of hydrogen atoms

In this reaction, the length of the hydrocarbon chain is determined by the alpha value, which is specific to the catalysts used and its sensitivity depends on the operating parameters [131, 132]. Two of the commonly used catalysts for FTS are iron and cobalt. For this simulation, due to the ability to produce a wide range of hydrocarbons (based on varying process conditions) [133], the catalyst is assumed to be iron and the corresponding reaction kinetics are determined based on literature data [134], as shown in Equation 4.4.

$$r_{FTS} = k_0 * \exp\left(-\frac{E}{RT}\right) \left(\frac{P_{CO}P_{H_2}}{P_{CO} + aP_{H_2O} + cP_{CO_2}}\right) \quad (4.4)$$

Where,

$$k_0 = 0.080 \text{ mol/g-cat.h.MPa}$$

$$a = 4.80$$

$$c = 0.33$$

$$E = 86 \text{ KJ/mol}$$

To provide a broad range of marketable products, the simulation is constrained to C<sub>1</sub>-C<sub>30</sub> alkanes. While the equations capture the variability, there are many realistic

challenges specific to the type of FTS reactor used, such as, selective product range, catalyst attrition and catalyst separation [135]. The developed model uses a tubular reactor to simulate the FTS process. A snapshot of the FTS flow sheet is illustrated in Figure 4.5. Once the hydrocarbons are produced, the final step is product separation.

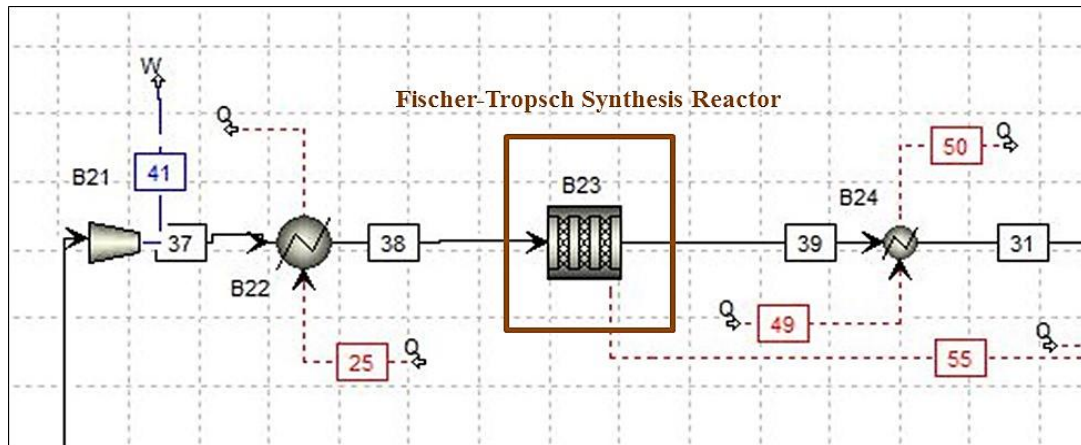

Figure 4.5 Process flow diagram of the Fischer Tropsch Synthesis unit

Selection of the product separation technique is reliant on the final choice of marketable products. Some processes, such as, production of gasoline or other commercial hydrocarbons require further processing. The research presented in the dissertation aims to maintain a broad product range in order to stay adaptable to the corresponding enhancing scenario. Presently, the products are separated based on the difference in volatilities by a series of distillation columns. The aim is to separate the products based on cuts of marketable commodities, such as,  $C_1$ - $C_4$ ,  $C_5$ - $C_8$ ,  $C_9$ - $C_{20}$  and  $C_{21}$ - $C_{30}$  [21]. These products are assigned a price based on the closest commercial hydrocarbons, such as, natural gas, gasoline, diesel and residual oil, respectively [136]. Practically, these values can be replaced by any relevant ones for potential products. Figure 4.6 demonstrates various units developed to separate the hydrocarbon cuts.

Once all the individual processes are developed, these are assembled to build the complete simulation model. Figure 4.7 illustrates the process flow diagram of the

entire biomass gasification facility. The developed process simulation model is capable of incorporating multiple bio-based feedstocks to produce varying quantities of power and a wide range of hydrocarbons. This attribute enables various runs to be performed on the simulation based on changing user requirements. Section 4.2.2.3 will demonstrate the manner in which these models can be optimized to further link to the decision support tool.

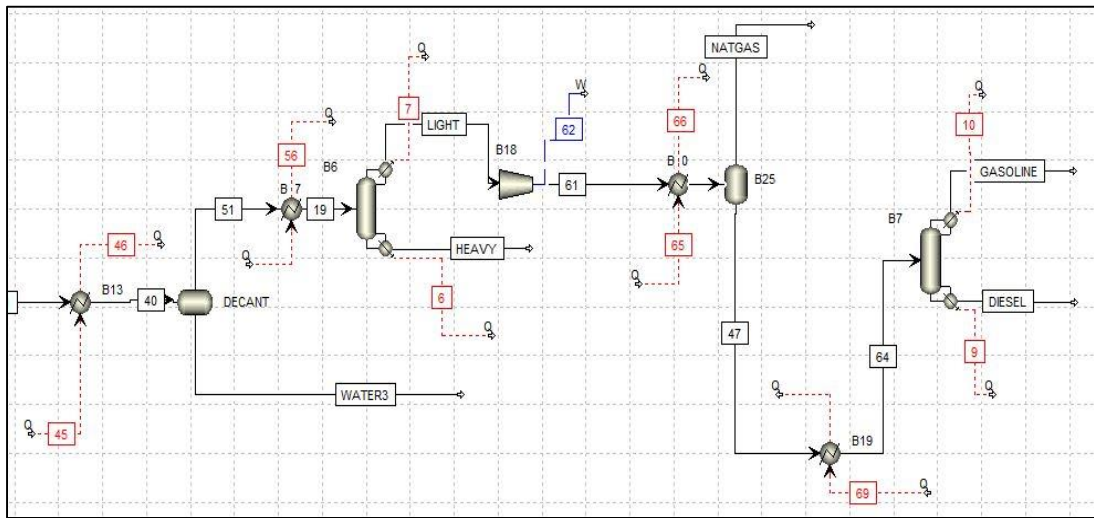

Figure 4.6 Process flow diagram (Aspen Plus®) for the hydrocarbon separation unit

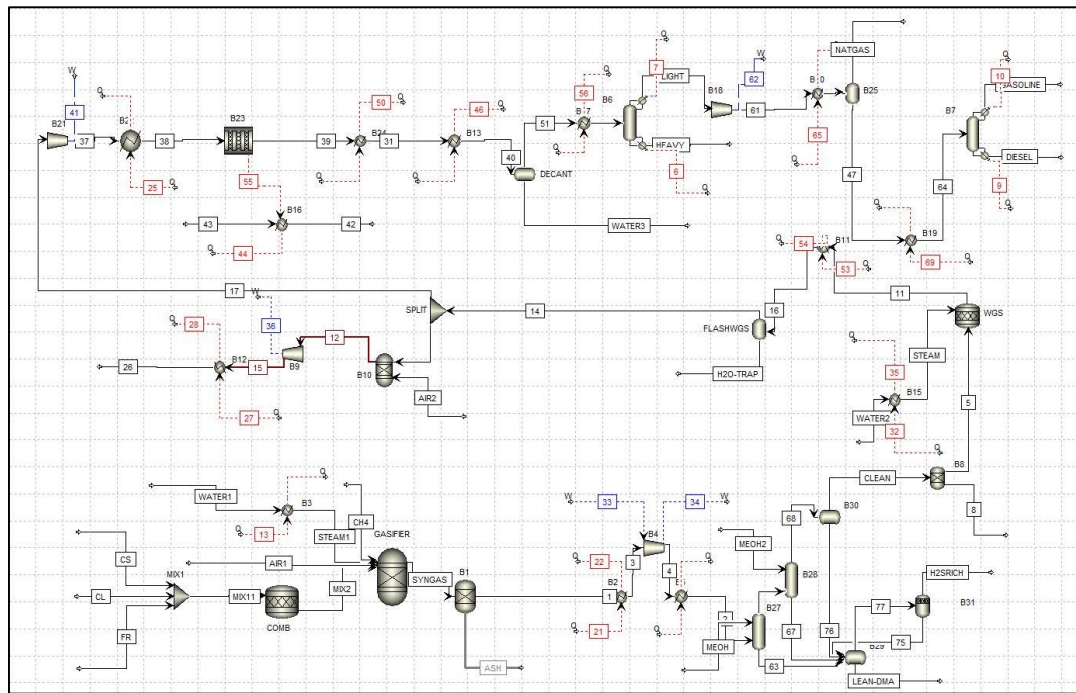

Figure 4.7 The screenshot of the entire process to produce biofuels and power from biomass via gasification

#### 4.2.2.2 Fermentation of Agricultural Residue (Biochemical Process)

One of the principal biomass feedstocks available in the USA is agricultural residues that is left after harvesting food crops. Among the available agricultural wastes, corn stover has been studied extensively for its applicability as a feed source for biorefineries. In 2011, approximately three-fourth of the country’s total agricultural residue consisted of corn stover [137]. The previous section focused on a feed flexible process for the production of liquid hydrocarbons from locally available biomass. This section, will focus on the development of a feed specific biochemical conversion process, using corn stover as a feedstock. Additionally, studies [138] have suggested that biochemical conversion to ethanol and electricity is advantageous when compared to the thermochemical alternatives based on the net energy created. Hence, biochemical conversion of corn stover to ethanol is the next process that will be studied. Also, by

utilizing details from a previous contribution by NREL [54], a process model will be simulated.

As discussed in the previous sections, incorporating non-conventional feed into the simulation model is a challenge. To address this issue, unlike thermochemical process simulation, the feed is specified based on the polymeric compounds present. Biomass mainly consists of lignin, hemicellulose and cellulose, with other organic and inorganic compounds found in trace amounts [139]. The simulation developed adopts the composition obtained from a previous contribution [54] to initiate the model. In the future, these compounds can be changed based on the analyzed composition of the feedstock. Table 4.4 shows the detailed feed composition used in the simulation.

Table 4.4 Composition of corn stover [54]

<b>Component</b>	<b>% Dry Basis</b>
Glucan	37.4
Xylan	21.1
Lignin	18.0
Ash	5.2
Acetate	2.9
Protein	3.1
Extractives	4.7
Arabinan	2.9
Galactan	2.0
Mannan	1.6
Unknown Soluble Solids	1.1

Once the compounds are entered, associated pure and binary component properties must be supplied to the simulation, as the model does not contain properties

for the non-conventional compounds. Another approach to define the feedstock is by specifying the molecular structure [140], however, while dealing with large polymers present in the biomass, specifying the compounds as solids will be a better approach. Specifying the biomass as solid will depict the actual composition of biomass with the least chance for misinterpretations.

After specifying the feedstock, the process flow sheet is built for physical pre-treatment. Here, the biomass is washed with water to remove the inorganics carried from the soil. Since this process consumes a large amount of water, the treated waste water can be potentially recycled to the process, in order to minimize the consumption of fresh water. The washed biomass is then fed to the size reduction equipment and the particle size is reduced to a maximum of 1 mm. Previously, it has been determined that the moisture content of biomass does not affect the process energy consumption significantly [141], but if required, a drying operation can be installed prior to the size reduction step. Also, for any customized pre-treatment, equipment power consumption can be calculated using the built-in “flowsheeting” functions. Figure 4.8 shows the process flow diagram for the physical pre-treatment. Finally, the screened biomass is sent to the chemical pre-treatment section.



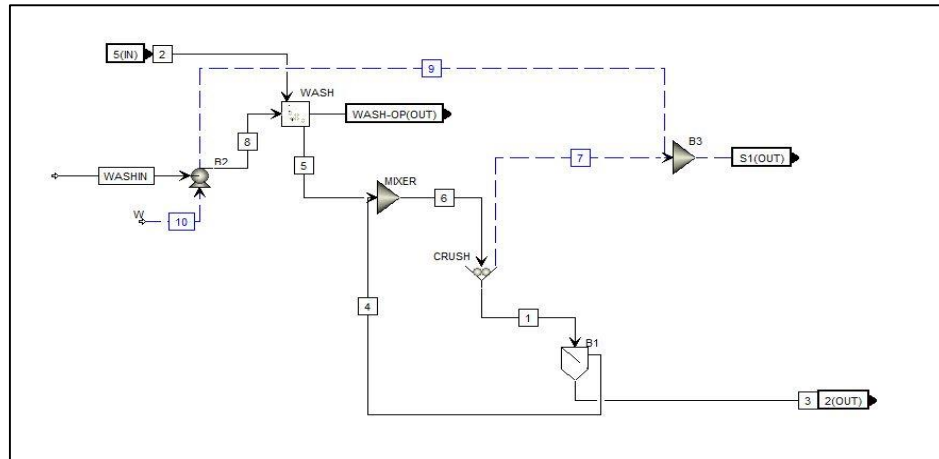

Figure 4.8 Process flow diagram of the mechanical/physical pre-treatment section

Biomass recalcitrance is a major aspect that limits the accessibility of enzymes to break down cellulose into fermentable sugars. The chemical pre-treatment section aims to partly solubilize lignin and convert a major fraction of hemicellulose and a small fraction of cellulose to sugars. The flow scheme of the process is designed based on NREL's publications [54, 55], however, for simplicity these have been altered to eliminate the complexities while abiding with all the major conversion processes. Biomass is treated with dilute sulfuric acid at high temperature, which is further processed to remove by-products, such as, acetic acid, furfural and primary hydroxymethyl furfural. Finally, the solids are washed and over-limed to increase the  $p^H$  of the treated biomass. This is followed by neutralization and separation of gypsum formed during the process. Figure 4.9 depicts a detailed schematic of the process flow diagram for this section. Various reactions and process parameters involved in the pre-treatment section are listed in Appendix A.1. It must be kept in mind that this is not a generic pre-treatment scheme. While several factors exist [142, 143], typically, the pre-treatment processes are designed based on increasing the cellulose or hemicellulose surface area available for the fermentation enzymes to act [143, 144]. The motive of

the simulation model is to incorporate various pre-treatment schemes depending on the need of stakeholders.

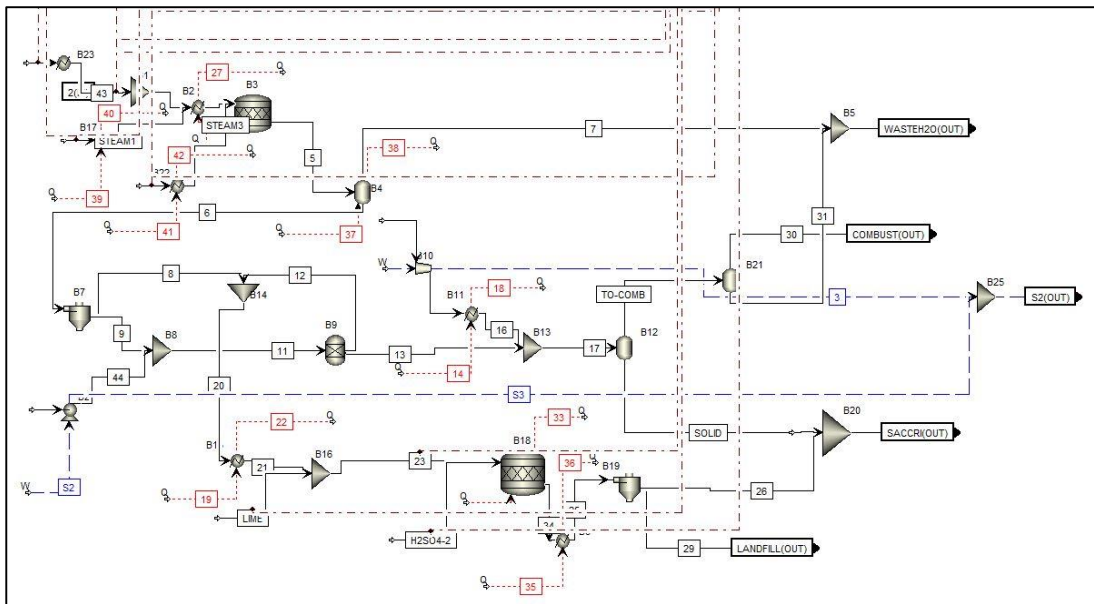

Figure 4.9 Schematic of the chemical pre-treatment section (Aspen Plus®) of corn stover

Following the pre-treatment is the main conversion process for the production of biofuels. The saccharification and fermentation section is simulated, which aims to increase the amount of glucose and ferment it to the final product (ethanol in this case). Similar to the pre-treatment section, this part of the overall process simulation is adapted from previous research by NREL [54]. The pre-treated biomass is sent to the saccharification reactor where it is operated at higher temperatures (65°C) and given sufficient residence time (36 hours). Following the saccharification, the sugar rich stream's temperature is reduced (41°C) to carry out the fermentation. *Z.mobilis* is the bacteria which is used by NREL for fermentation. Appendix A.2 explains various reactions and corresponding parameters involved in the process. A detailed schematic of the saccharification and fermentation process is shown in Figure 4.10. The product

stream from this unit is pumped to the purification section, where ethanol will be separated.

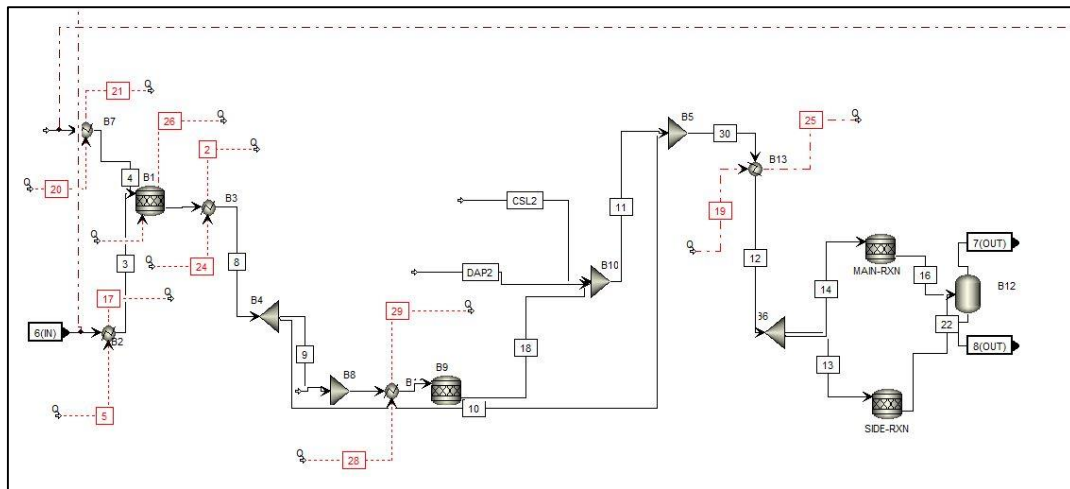

Figure 4.10 Process flow diagram (Aspen Plus®) of the saccharification and fermentation process

One of the major challenges of the overall process is the recovery of ethanol from the fermentation broth. While many processes exist [145-148], this simulation is designed for ethanol recovery using distillation, followed by the final separation using a molecular sieve. The two distillation columns are simulated and designed to remove all the impurities and bring the ethanol concentration close to the azeotropic composition. Further, desired separation is achieved by sending the ethanol-water stream to a molecular sieve. The molecular sieve has not been designed for the simulation and it is assumed that the operation will achieve a desired separation of 99.5% and the resulting ethanol is sold as the primary product. Finally, the product ethanol is sent to the storage facility. The bottoms from the distillation column is channeled to the treatment plant along with waste water streams from the fermentation and pre-treatment sections. Figure 4.11 presents the process flow diagram of ethanol recovery unit used in the simulation.

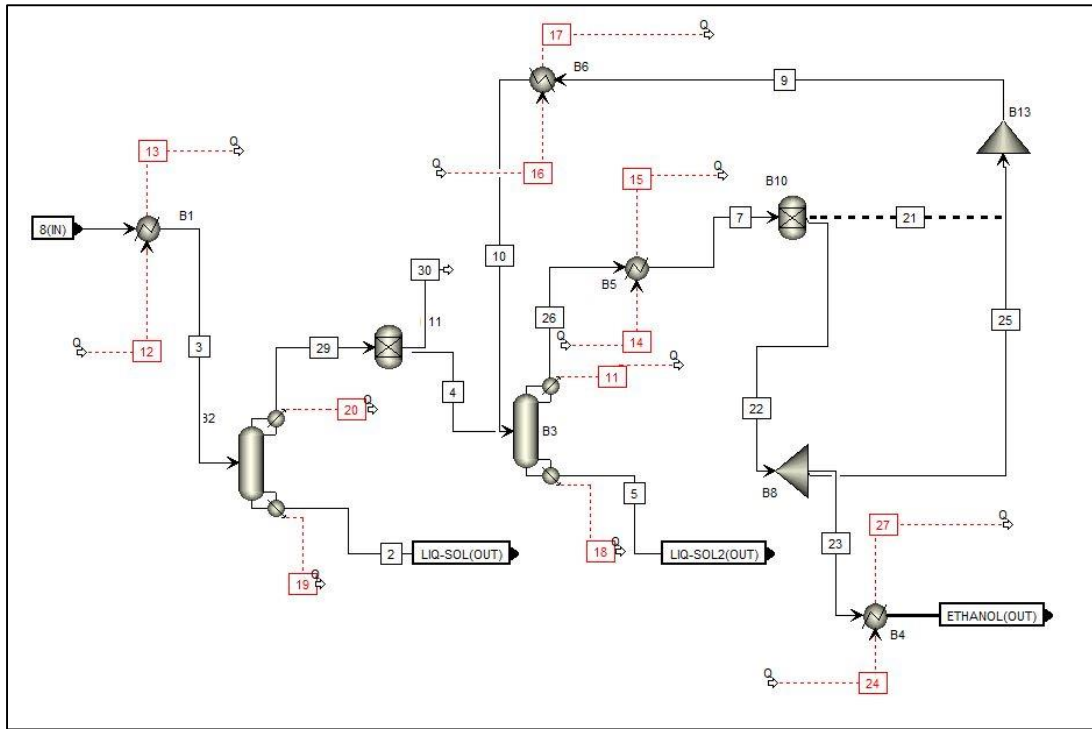

Figure 4.11 Schematic (Aspen Plus®) of the ethanol recovery operation

Fresh water is one of the major raw materials required for a biorefinery based on biological conversion techniques. In order to reduce the consumption of fresh water, a waste water treatment plant is simulated. The treatment plant gathers waste water streams from the processes and is sent to a filtration unit where organic solids particles present are removed. This is followed by heating the waste water to 35°C, before it is directed to the anaerobic reactors. Here, all the soluble compounds are assumed to be converted into CO<sub>2</sub> and CH<sub>4</sub>. The two greenhouse gases produced are trapped by flashing the treated waste water stream. Once the gases are removed, the waste water is sent to an aerobic treatment tank. In this process, all the leftover organic compounds are reacted with oxygen in an aerator to produce CO<sub>2</sub> and H<sub>2</sub>O. Finally, the treated water is recirculated and used in processes, such as, washing the biomass, physical and chemical pre-treatment operations. The conversions in the anaerobic and aerobic reactors are based on literature values [54]. Figure 4.12 shows the schematics of the

process flow diagram for the waste water treatment plant. It must be noted that in a potential biorefinery (based on biochemical reaction), a major portion of lignin, initially present, is left unreacted at the end of the process. There are ways to decompose the residual solids, such as, land fill applications and incineration. In this process, the solids that are filtered prior to the water treatment operations are combusted in a furnace to produce steam and process heat.

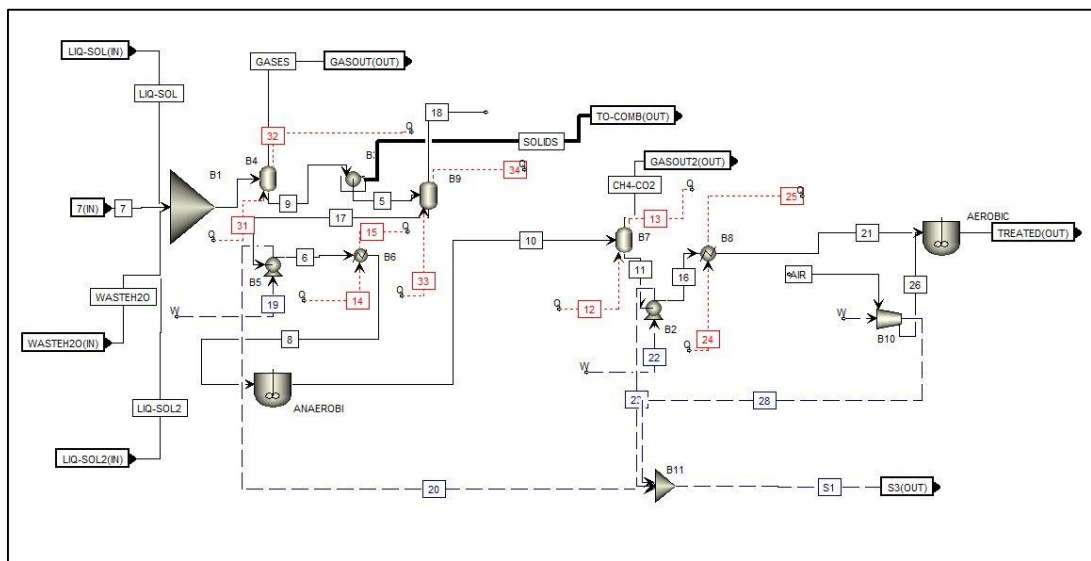

Figure 4.12 A process flow diagram (Aspen Plus®) to treat the waste water

The final operation of the simulation aims to create useful process heat and electricity. The main objective of this operation is to create useful utilities by combustion of waste residues. The solids recovered from the waste streams are gathered and dried with air to remove the major portion of the moisture entrained. The dry organic waste is funneled to a furnace, where it is burned in the presence of excess air. The resulting heat is used to produce steam which is passed through a turbine to generate electricity. The flue gases from the combustor is channeled to a cyclone separator to remove ash particulates. The unit operations described is a possible way to



the economics of any biorefinery process. Figure 4.14 demonstrates the final process flow diagram developed for this purpose. All the major unit operations are moved inside the hierarchy blocks, enabling improved freedom to change properties and provides a hierarchical structure to the simulation.

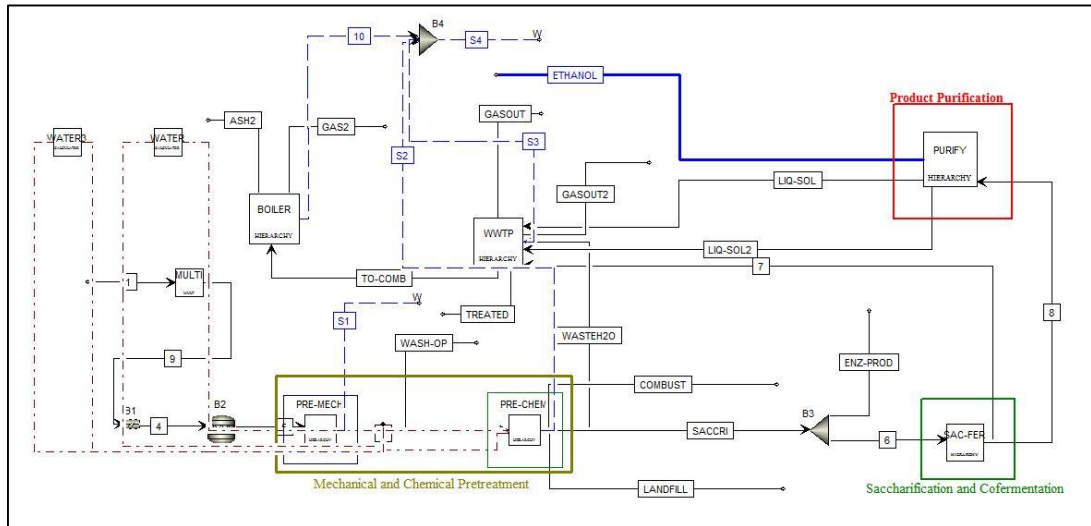

Figure 4.14 Process flow diagram (Aspen Plus®) of the entire process to convert corn stover to ethanol

The developed simulation is then tested under various feed rates and is equipped to perform the required runs. The following sections will demonstrate how these developed process models can be used to predict the optimum operational configuration for any given constrained objective.

#### 4.2.2.3 Process Optimization

The process simulations developed so far are steady state models and can only be used to perform one run, based on the provided input. However, in order to use the simulation as a guiding tool, various other built-in functions, such as, “Flowsheeting options” and “model analysis tool” can be utilized. For a given process, there could be several objectives based on the stakeholders interest. For instance, from an investment point of view, the objective function is to maximize profit, whereas from an

environmental perception, the goal is to reduce emissions. Hence, the developed model must be adaptable to such varying applications. In order to initiate the optimization process, each of the streams (input, output and intermediate) must be assigned a price based on literature data [55]. Table 4.5 and 4.6 show the costs assumed for various streams present in the thermochemical and biochemical processes, respectively. Whereas, Tables 4.7 and 4.8 demonstrate the utility and the feedstock cost, respectively.

Table 4.5 Costs assigned to products for the biomass gasification process [136]

<b>Stream</b>	<b>Price</b>	<b>Unit</b>
<b>Natural gas</b>	4.0	\$/Mcuft
<b>Gasoline</b>	3.5	\$/gal
<b>Diesel</b>	4.0	\$/gal
<b>Residual oil</b>	2.5	\$/gal

Table 4.6 Price of streams for the biological conversion process [54]

<b>Stream</b>	<b>Price</b>	<b>Unit</b>
<b>Ethanol</b>	2.5	\$/gal
<b>H2SO4</b>	94.00	\$/ton
<b>Diammonium Phosphate</b>	400.00	\$/tonne
<b>Water</b>	0.001	\$/gal
<b>Enzyme</b>	0.060	\$/gal
<b>Ca(OH)2</b>	50.00	\$/ton
<b>Corn steep liquor</b>	0.36	\$/gal

Table 4.7 Utility costs used for the developed simulations [123, 136]

<b>Utility</b>	<b>Price</b>	<b>Unit</b>
<b>Cooling water</b>	$8.89 \times 10^{-10}$	\$/cal
<b>Electricity</b>	0.07	\$/kWhr
<b>High Pressure Steam</b>	$1.04 \times 10^{-8}$	\$/cal
<b>Medium Pressure Steam</b>	$0.92 \times 10^{-8}$	\$/cal
<b>Low Pressure Steam</b>	$0.79 \times 10^{-8}$	\$/cal

Table 4.8 Assumed (to initialize the runs) costs for the developed simulations

<b>Stream</b>	<b>Price</b>	<b>Unit</b>
<b>Forest residue</b>	40	\$/tonne
<b>Corn stover</b>	60	\$/tonne
<b>Chicken litter</b>	50	\$/tonne
<b>Switchgrass</b>	60	\$/tonne



Another major input to the model is the utility costs. The operations involved in both the processes (thermochemical and biochemical) are assigned with utilities, such as, steam, cooling water, refrigerant and electricity. Also, ports are available in Aspen Plus® to incorporate other cooling and heating entities, such as, low temperature, hot oil and very high temperature utility. Once these are specified, the unit operations are assigned with the appropriate utilities. Based on the objective function, these specified streams can be called by the built-in “optimization” function present in the Aspen Plus® “model analysis tool”. Finally, variable ranges and constraints are set based on which the simulation runs and optimizes. This application of the simulation consumes more time and it may in some cases, require several iterations before it converges. Equation 4.5 and 4.6 shows the type of objective functions that have been used to run the simulations for optimization.

*Maximize Profit*

$$Profit = Product\ Sales\ Income\ (PSI) - Biorefinery\ Operating\ Cost\ (BOC) \quad (4.5)$$

OR

*Minimize Operating Cost*

$$BOC = Variable\ Feed\ Cost\ (VFC) + Chemicals\ Cost\ (CC) + Utility\ Cost\ (UC) \quad (4.6)$$

Where

$$PSI = \sum_{h=1}^a C_h P_h, \quad VFC = \sum_{w=1}^b B_w F_w, \quad CC = \sum_{v=1}^d Q_v G_v$$

$$UC = CH \sum_{x=1}^e QH_x + CR \sum_{y=1}^f QR_y + CC \sum_{z=1}^g QC_z$$

Subject to:

$$A = CL*O_p, \quad D = FR*O_q, \quad R = CS*O_r$$

$$0.9 \leq O_p \leq 1, \quad 0.9 \leq O_q \leq 1, \quad 0.9 \leq O_r \leq 1$$

Table 4.9 Notations and subscript indices

$C_h, B_w, Q_v$	Product (\$/gal), feed (\$/kg) and chemical (\$/kg) unit cost, respectively
$P_h, F_w, G_v$	Product (gal/s), feed (kg/s) and chemical (kg/s) flow rate, respectively
$CH, CR, CC$	Cost of hot, refrigeration and cold utility, respectively (\$/J)
$QH_x, QR_y, QC_z$	Hot, refrigerant and cold utility consumed (W)
$CL, FR, CS$	Generated chicken litter, forest residue and corn stover (kg/sec)
$A, D, R$	Rate of input of $CL, FR$ and $CS$ , respectively (kg/sec)
$O_p, O_q, O_r$	Non-negative multiplication factor of $CL, FR$ and $CS$ , respectively
$a, b, d$	Number of product, feedstock and chemicals, respectively
$e, f, g$	Number of hot, refrigeration and cold utility streams, respectively

The simulations are optimized either to maximize profit or minimize the utility consumption. An optimum feed ratio and the corresponding product slate can be determined as a major output from the simulation. Critical operating parameters, such as, optimum raw materials and utility costs along with the details regarding effluents and gas emissions are obtained. The emission details may not be conclusive as several other factors involved during the life cycle must be considered. Nevertheless, it is possible that other potential process configurations and utility schemes may exist. In order to determine the optimum utility network, heat integration will be performed that will be elaborated in the following section.

### 4.2.3 Heat Integration

The processing of biomass to biofuel requires continuous availability of utilities that contributes to the variable operating costs [149]. Studies are performed which focus on the simultaneous process and heat integration approach [80, 150]. While these notions are an effective way of optimizing, intensive computational power and heavy reliability on the detailed process data, makes the models cumbersome. The approach shown here is simple yet unique as it uses the Aspen heat integration tool (Aspen Energy Analyzer®) to optimize the utility consumption. This method of heat integration is distinct and can be used to incorporate all the process details pertaining to the simulations developed in Aspen Plus®. This approach has been used in the petroleum and chemical industries for years and can have its applicability in biorefining as well.

The optimized flow sheet described in section 4.2.2.3 is run and the necessary process data are exported to the Aspen Energy Analyzer®. The data is then interfaced by the software to develop a heat exchanger network diagram. The model is run to produce recommendations on improved heat exchanger network designs, based on minimizing exchanger area or the total annualized cost. Among the many suggested, a feasible configuration is selected and changes are made to the original process simulation (in Aspen Plus®). The process requires a few iterations before the best configuration is determined to minimize the utility. Figure 4.15 shows a heat exchanger network for corn stover fermentation process.

Heat integration is performed under certain constraints, such as:

- Maximum parallel branching allowed for a process stream is set to be two.
- The  $\Delta T_{\min}$  is assumed to be 10°C
- Minimum Log Mean Temperature Difference (LMTD) correction factor is 0.8

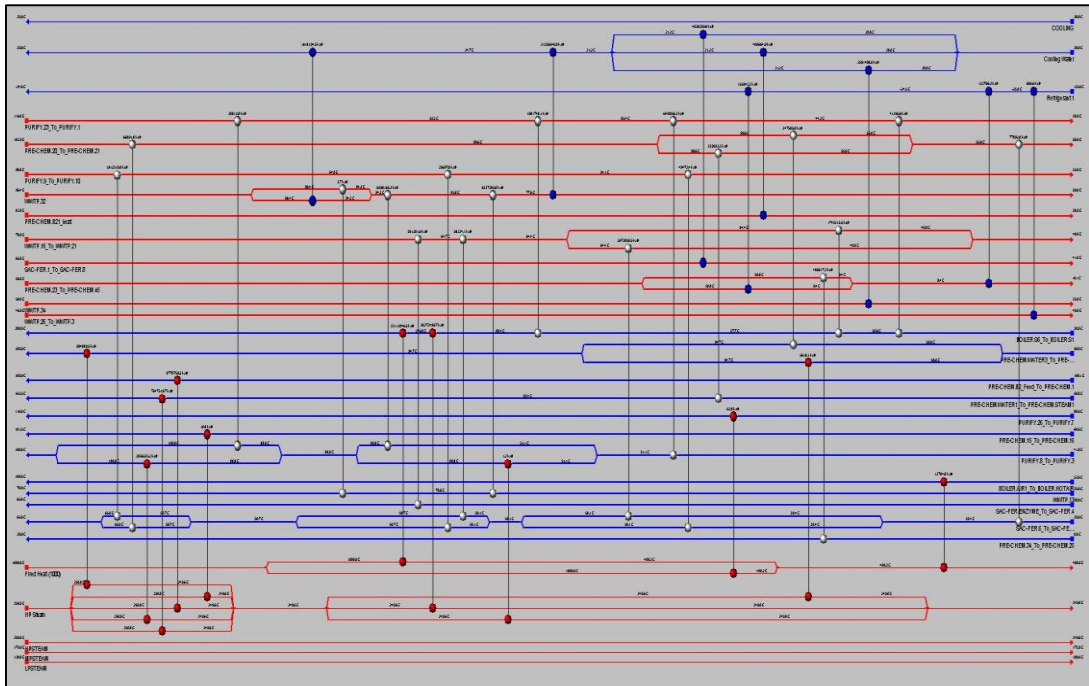

Figure 4.15 Heat exchanger network suggestion obtained from Aspen Energy Analyzer®

Adding to its merits, the approach shown here has several other advantages including omission of any infeasible process stream, checking the possibility for inclusion of alternative utilities, analyze network costs and the potential savings, etc. Hence, this method demands human judgment prior to the selection of the final configuration. The optimized and integrated process is then appraised for its environmental impacts.

#### 4.2.4 Environmental Impact Assessment

The details obtained from the process simulation is extensive in terms of composition. Various effluent streams are determined, but in order to compare these on a common basis, a method is necessary that can assign values based on the impact of energy consumed by the facility. The framework uses the Waste Reduction (WAR) algorithm [91], developed by US EPA. The WAR algorithm compares processes based on the effluents and the source of energy used to generate utilities for the process. As

an added advantage, the software has an interface to import streams present in the Aspen Plus® process simulation.

Both the thermochemical and biochemical processes can be linked to the WAR algorithm and it can be compared for its environmental impacts. The simulations developed do not account for several inorganic compounds present in the feedstock. For instance, the biomass feedstock contains compounds and elements that are cumulatively accounted as ash in the proximate and ultimate analysis data. The ash left after the gasification process still contains these elements or the corresponding oxides in it. However, a detailed analysis on these compounds has not been performed, yet. Therefore, the results obtained so far do not consider these impurities and their potential impacts.

Another use of this tool is to check various utility or process schemes for the best environmental performance. Hence, the results obtained can be used to analyze process configurations, based on which, changes can be fed back to the process optimization model. While other versatile environmental assessment tools exist [92], the use of WAR algorithm is to demonstrate the ability of the framework to be linked with such models. If recalled, the main goal of the framework is to determine the optimum operating configuration based on the economic value. Once the optimization, heat integration and emission assessment stages are completed, the resulting process simulation represents a model of an optimally operating plant. At this point, the process simulation model is fixed and ready to estimate the capital investment required to build a biorefinery.

#### **4.2.5 Capital Cost**

So far the investment costs accounted for are mainly variable operating costs. Detailed analysis must be done which includes the investment required to build the

facility, purchase process equipment, maintain and operate the biorefinery. For this framework, Aspen Economic Analyzer® is the software that is used to estimate the capital cost of a biorefinery. Similar to Aspen Energy Analyzer®, Aspen Economic Analyzer® has a simple interface with the Aspen Plus® steady state simulation. This virtue enables swift export of process equipment and operations data to the Aspen Economic Analyzer®.

For this framework, the process equipment is sized and evaluated for its capital cost based on the materials of construction, process parameters, auxiliary parts, piping etc. Most of the equipment used currently are present in the software database, however, a few (gasifier, molecular sieve, etc) are not currently available. This equipment is assumed to have the same cost as vessels that closely resemble the original ones. For accuracy, this exercise must be carried out by sharing design specifications with the concerned vendors. Previous contributions [54, 151] used vendor data to provide realistic economic estimates. Chapter 6 and 7 will elaborate on the results obtained by this model and describe how it can be used to perform investment analysis.

Previously, individual simulation tools have been used, however, this novel contribution aims to link these in an iterative manner. The following section will demonstrate the method by which the runs are being performed. The virtue of this contribution lies in bringing various simulation and optimization models together to build a process optimization framework that can run in an iterative manner. This is the first step in building the multidisciplinary framework for economic optimization. Figure 4.16 illustrates a data flow scheme that describes the running of the process optimization model.

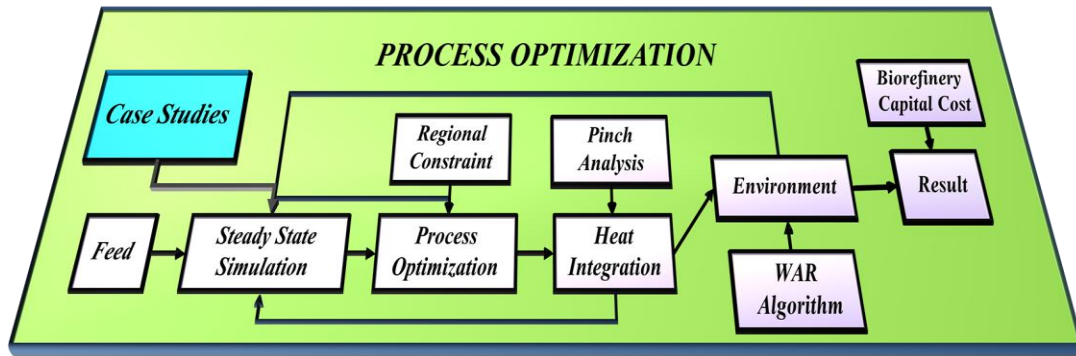

Figure 4.16 Methodology in which the data flows between various models to optimize the biorefining process

The data flow scheme starts with the selection of the conversion process that needs to be simulated. The process simulation model is developed for the chosen process and thereafter the operations of the process is optimized based on the desired objective. Subsequently, the process is checked for the best heat exchanger configuration by exporting the process streams to Aspen Economic Analyzer®. If a better configuration for the same process is determined, suggested changes are incorporated in the process flow diagram. Consequently, the process is assessed for its environmental impacts by using the WAR algorithm. Finally, the process data is exported to Aspen Economic Analyzer® to calculate the capital investment, operating and maintenance cost for the biorefinery. The model developed gives several specifics that can be used by the supply chain optimization model and discrete even simulation model. Hence, the development of the described process optimization model opens a venue for a novel contribution in determining the optimum supply chain configuration.

### 4.3 Linking of the Models

The process optimization model developed provides key details which are of great value, marking the beginning of the multidisciplinary iterative process. However, in order to capture the complete scenario, the transportation logistics of biomass cannot

be ignored. Subsequently, the developed process optimization model should share the optimum feed ratio, product slate, operating costs and capital investment values with the supply chain optimization model. The supply chain model to be described in the following section has been published previously [22].

#### **4.3.1 Supply Chain Optimization**

In order to create a framework, a methodology is proposed for preliminary analysis, which will be implemented in a case study as a proof of concept in the following sections. To begin analyzing the overall supply chain for producing biofuels from biomass, the first step is to assess the amount and type of feedstock available in the region of interest along with its respective locations on the map. A simple pictorial representation of this supply chain is illustrated in Figure 4.17.

The MILP optimization model used in this work is a published contribution from previous research [22] using IBM ILOG® Optimization Programming Language (OPL). As described in the section 4.2.1, details regarding the feedstock present in various sites are an input to the optimization model. Once the feedstock source locations are established, a decision must be made regarding the optimal path from source to the biorefinery. All the potential biorefinery locations must be considered based on the road network, followed by the selection of an appropriate conversion technique depending on the feedstock to product pathway. Finally, the respective logistics for the transportation of feedstocks and products need to be optimized. The published code in the original work is modified to incorporate the annualized capital cost. Appendix A.3 shows the objective function and constraints used in the model, followed by the modified code for the gasification and fermentation processes. It must be recognized that for any given capacity, the developed model determines an optimum biorefinery supply chain along with the amount of product and feed to be transported. However the



model does not account for uncertainties involved in feedstock availability and product demand. Nevertheless, the supply chain optimization model provides a snapshot of the supply chain configuration for a centralized integrated biorefinery.

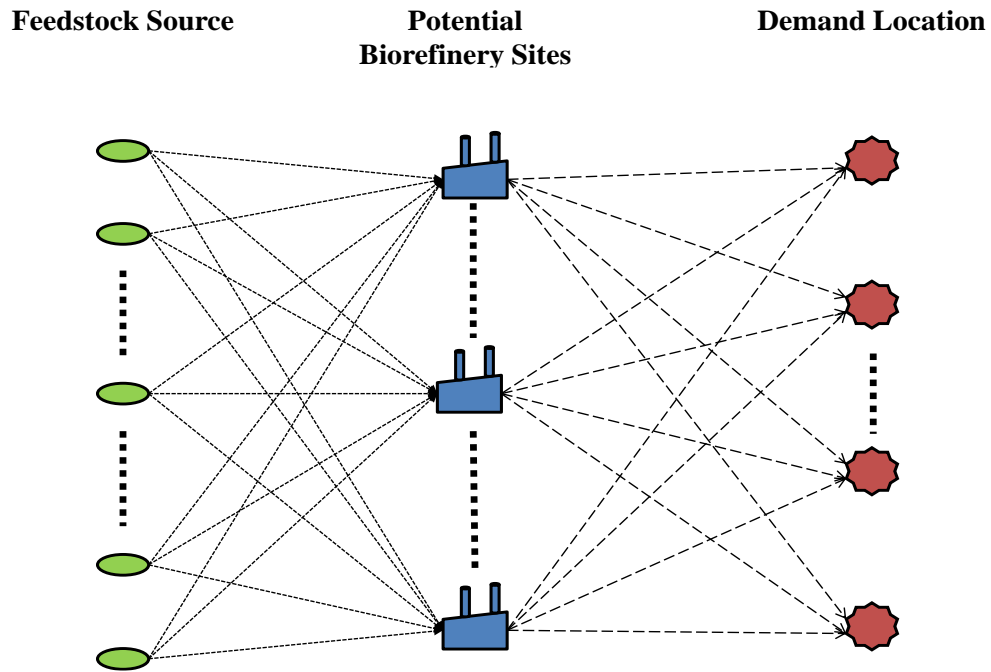

Figure 4.17 A simple supply chain scheme to demonstrate the scope of transportation details that will be covered in this contribution [21]

### 4.3.2 Discrete Event Simulation

While the MILP model, discussed previously, yields an optimal supply chain, its optimality is subject to the assumed conditions used to generate it. Moreover, with uncertainty in the availability of feedstocks, such as, forest residue, corn stover and animal wastes, over time can have tremendous influence on the upstream and downstream supply chain performance. Similarly, profitability of the supply chain is directly linked to the demand variability for its products in the potential marketplace. Discrete event simulation models represent reality as a sequence of events that changes the state of a system at an instant and have been used widely to simulate operation-level performance of supply chains [152]. Using this tool, one can simulate biorefinery

supply chain activities accounting for biomass generation, transportation, conversion to final product, product distribution and sale. The model developed by Amundson (2013) [89] provides a means to examine the economic performance of a biofuel supply chain over time including consideration for supply and demand variability. Distributions are determined in this work based on publically available feedstock generation data for a selected region. Similarly, product demand distributions based on historic consumption data are generated. Using the optimal supply chains generated from various scenarios determined via the MILP framework and process parameters from process optimization model, the simulation (discrete event simulation) can be used to forecast the net present value of an investment in biorefining over a specified period of time. Performing this iteratively resulted in the determination of an optimal biorefinery capacity and the dynamic nature of overall supply chain performance can then be examined for the impact of uncertainty over time.

#### **4.4 Techno-Economic Framework**

So far, the work described through this research is focused on developing standalone simulation and optimization models [21, 22, 89, 90]. While these contributions are unique on their own, the research can be further enhanced, provided, a method for linking these detailed models is determined. The iterative linking of the models will open a new horizon with endless possibilities for adding details to the existing framework. Nevertheless, to attain the previously described linking, individual models must be tailored so that continual runs are assured with the least computational burden.

The major details required to initiate the model are, determining the availability of feedstocks, demand of products and their corresponding locations on the map

(depending on how the distance array is calculated [22]). Based on the availability and demand, potential biorefinery conversion processes are selected. Subsequently, process simulation models (thermochemical and biochemical) are developed and optimized as described in section 4.2. The results from the developed model is then interfaced to Microsoft Excel® via a dedicated Visual Basic® (VB) application interface. This operation marks the end of the process optimization segment. It must be reemphasized that the model performs as a black box and the process variables are not accessible for change during the iteration.

The MILP optimization model requires data, such as, feed at the biorefinery location, operating costs, capital investment and products produced at the facility. These details are shared via Microsoft Excel® which has an interface with IBM's ILOG OPL® (used to run the MILP). Based on the objective function, the MILP optimization model determines a high resolution supply chain configuration. The combined results obtained by the deterministic models are verified for their operating profitability. Any non-profitable scenario is discarded and the capacity of the biorefinery will be varied until a positive operating profit is achieved. In order to avoid vacillation, the iteration is started with the maximum capacity (determined based on the available biomass) and reduced progressively to reset the iteration. Finally, the cumulative costs and supply chain details are transferred to the discrete event simulation model.

The discrete event simulation is based on distributions available from historic data and hence captures the effect of upstream and downstream uncertainty over time. The simulation is run for a defined timeframe into the future to determine the economic variability. Finally, the results obtained are checked for their operating profitability and the capacity of the plant is reset for any non-profitable scenario. Each of the screened

scenario (based on profitability) is recorded for further analysis. Chapter 6 and 7 will describe the application of this methodology for the biorefinery processes. Figure 4.18 illustrates a data flow scheme for the developed multidisciplinary framework.

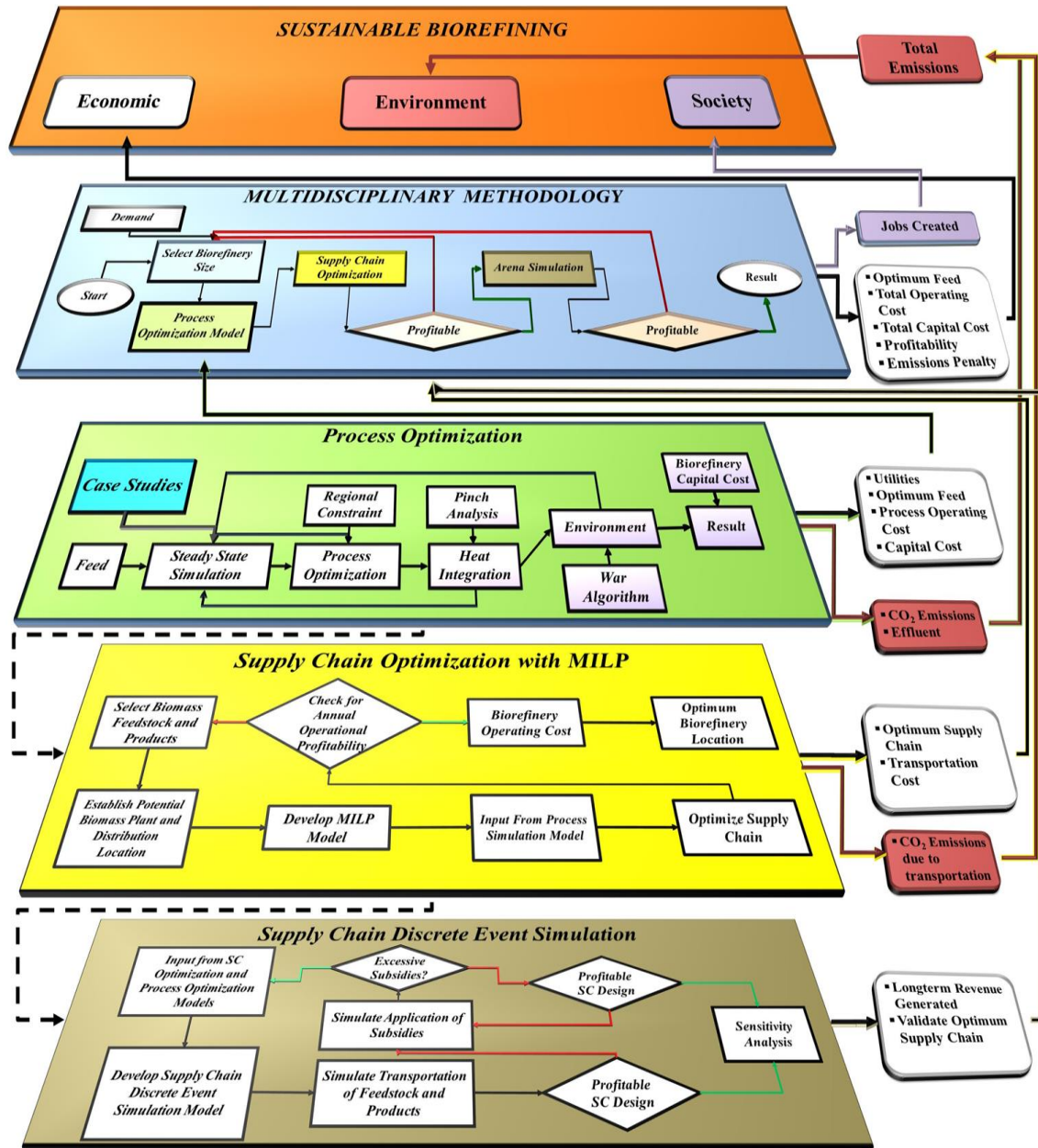

Figure 4.18 The final techno-economic framework developed, showing layers of flow of information to validate biorefining

For clarity, it is reaffirmed that the broad objective of the research is to evaluate sustainability of the biorefining processes. However, the current focus of this

dissertation is to establish economic viability. In the future, environmental and societal impact assessment tools must be added to the framework to validate the applicability of any biorefining process.

#### **4.5 Conclusions**

In order to estimate the economic impacts of biorefining processes, it is necessary to consider multiple aspects of the supply chain. As described previously, this contribution paves a way to perform economic assessment by incorporating conversion process and transportation optimization model into a framework. This unique contribution is generalizable and can be used by stakeholders to estimate potential economic outcomes in their respective area of interest.

In summary, the framework developed can be used as a decision support tool by investors, policy makers, environmentalists and growers, to evaluate the viability of any bio-based resource to produce biofuels. In order to justify the assertion, case studies are performed on the developed processes in previously described manner. These studies will act as a proof of concept, further justifying the need for a multidisciplinary decision support tool.

## **5. Designing Proof of Concept Studies – Demonstrating the Working of the Developed Multidisciplinary Decision Support Framework**

The development of an informative decision support tool for biorefining is a unique contribution in the field of PSE. The framework developed has linked various computational tools to create a versatile multidisciplinary model. The resulting model is a novel contribution that aims to provide insight towards the long-term economic viability of biorefining from a multi-stakeholder perspective. In order to fortify the assertion, case studies must be performed that demonstrate the applicability and generalizability of the model.

### **5.1 Determining a Region to Perform the Case Studies**

The primary step to perform case studies to evaluate the feasibility of biorefining is to select a suitable geographic location. While most regions have varying quantities of bio-resources in one form or another, in order to show the broad applicability of the framework, it is necessary to select a region that can supply diverse feedstocks. Also, the selected region should encompass most of the possible biorefining pathways, i.e. the region should have the potential to supply large quantities of feedstocks to produce multiple products using various conversion techniques.

In order to demonstrate the applicability of the proposed model, case studies are performed in the Jackson Purchase region of Western Kentucky, USA, which has ample access to coal, waste forest matter and agricultural residues, like, corn stover and wheat straw [153]. This region is also home to hundreds of poultry farms that may serve as a provider of chicken litter, which has applications for a biorefinery as an additional potential feedstock [74]. The mix of locally available biomass feedstock make it an attractive choice for a case study. This region has an estimated population of 200,000 with a demand for transportation fuel and energy. Based on the biomass available and

the pathways shown in Figure 2.1, various products, such as, natural gas, gasoline, diesel, heavy oils, ethanol and power are determined to be viable products in the region. Also, the region has access to water due to the presence of rivers adjacent to the area and has a developed road network for transportation of feed as well as the biorefinery products. A map of the Jackson Purchase region is shown in Figure 5.1 with locations of the feedstocks, potential biorefinery and product depot.

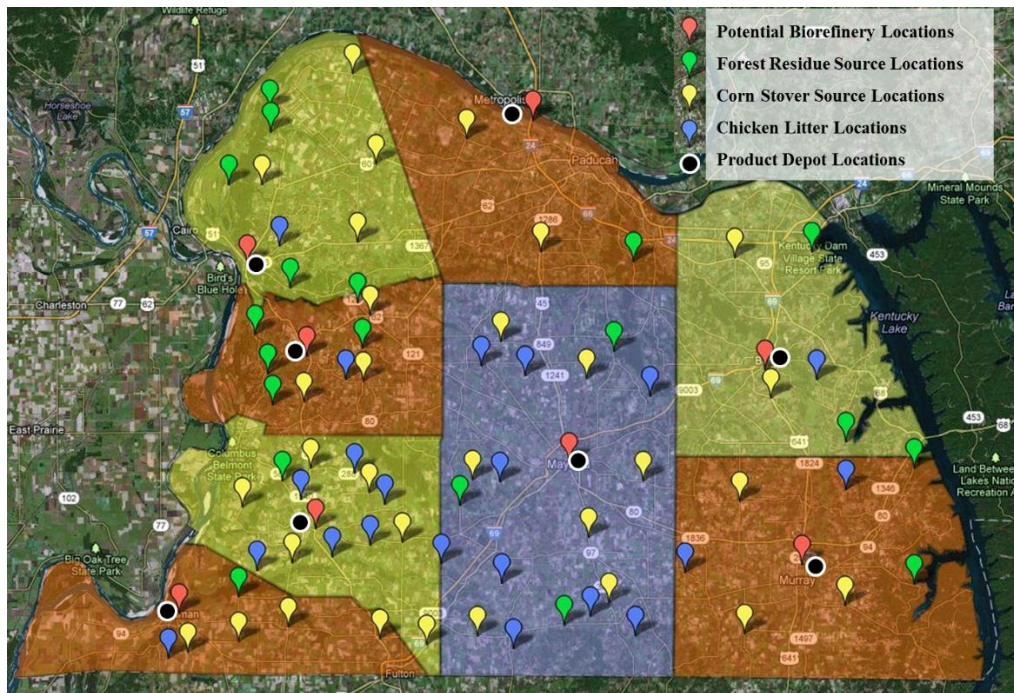

Figure 5.1 Feedstock, potential biorefinery and product depot locations (Google Maps®) in the Jackson Purchase region [21, 22, 154]

Note: The feed locations are shown by yellow, green and blue for corn stover, forest residue and chicken litter, respectively. Whereas, the red and black points on the map shows the potential biorefinery and product depot locations, respectively, which are inputs to the MILP model.

The methodology developed through this research starts by gathering information regarding the feedstock available using GIS in the region of interest.

Process simulations are run for an individual feedstock to establish an estimate for the maximum quantity that can be consumed. Individual feedstock simulations (Aspen Plus® process simulation runs) are recorded for calculating the maximum amount of biofuels that can be produced based on the local availability of biomass. This is used to set a maximum capacity for the plant to start the iterative process. Previous work [90] shows the detailed feedstock portfolio, developed depending on the biorefinery plant size and gate energy needs. These are assigned based on availability and energy content of the feedstock. Gate energy needs refers to the total potential of a feedstock to create energy, assuming a plant efficiency of 35%. Thus, from the total energy needs and energy density of each feedstock, the amount of feedstock to be shipped is calculated. The calculated detailed feedstock requirements are presented in Table 5.1. However, the present model focuses on capturing extensive results, such as, the effect of change in feedstock availability and capacity on project economics and potential biorefinery locations.

Table 5.1 Calculated monthly portfolio for feedstock requirement in the Jackson Purchase region

Feed	August	September	October	November	December	January	February	March	April	May	June	July
Chicken Litter (10 <sup>6</sup> kg)	1.38	1.38	1.38	1.38	1.38	1.38	1.38	1.38	1.38	1.38	1.38	1.38
Corn Stover (10 <sup>6</sup> kg)	9.24	9.72	10.14	9.72	10.14	10.14	7.99	9.24	8.82	9.24	8.82	9.24
Forest Residue (10 <sup>6</sup> kg)	2.34	1.56	1.56	1.56	1.56	2.34	2.34	2.34	2.34	2.34	2.34	2.34

## 5.2 Reasoning Behind Selecting the Case Studies

Planning the case studies is a critical aspect that must be performed to validate the operations of the developed model. For biorefining, there are several theoretically



feasible process combinations that can be considered. However, it is desirable to design the case studies such that they can capture diverse applications of the contribution. Nevertheless, the case studies must demonstrate the manner in which the iterations must be performed with the process simulation and supply chain optimization models to share information and finally validate the optimal configuration. The research presents multiple proof of concept results that substantiate the working of the framework. These studies examine various existing, emerging and potential process configurations for a given region of interest (in this case, the Jackson Purchase region). The following subsections will elaborate on the reasoning behind selecting the processes for case studies.

### **5.2.1 A Proven Conversion Technique**

At first, in this contribution, the established process of gasification is studied for its viability in the Jackson Purchase region. There have been many instances where the process of gasification has shown practical viability and is used with both coal and biomass to produce liquid fuel and power. However, we still lack sufficient confirmations which can prove the application of biomass gasification as a viable option for the long-term. Also, if proven profitable, the optimum product slate for the region must be determined. In this case study, the framework is developed to test the viability of biomass gasification, in the Jackson Purchase region, to produce liquid hydrocarbons and electricity using corn stover, chicken litter and forest residue as feedstocks. Chapter 6 states the detailed assumptions, methodology and results obtained for the process. This proof of concept demonstrates the ability of the framework to incorporate thermochemical processes. Also, the case studies explain the type of inputs that needs to be varied in order to generalize this model to any given region. Eventually, this tool can be used by investors and policy makers to justify their judgment and decide policies to mitigate financial adversities.

### **5.2.2 An Emerging Conversion Process**

Currently, several biosynthesis pathways are being explored to convert bio-based raw materials into biofuels. So far, bioethanol which is derived from first generation biomass, is a major biofuel [155] that is used in blending with the gasoline derived from fossil based resources. Currently, various alternatives for producing bioethanol, bio-butanol etc. from lignocellulosic biomass are being explored [156]. While, bio-butanol is a promising alternative that has potential to replace a major portion of gasoline [157], in comparison to bio-ethanol it has been determined to be less economically viable [158]. Hence, for this framework, the biological process to be developed initially is the conversion of corn stover to ethanol. In the future, as metabolic engineering applications materialize with improved resistance of microorganisms [159], subsequent process simulations to convert dedicated energy crops to butanol will be studied. Such an assessment will be of great value to experimentalists, as they can justify their experimental research outcomes.

### **5.2.3 A Hypothetical Scenario**

A major virtue of an ideal decision support tool is to foresee the potential opportunities to improve the profit for any flourishing scenario. Hence, the developed tool can be used as a guide by growers and policy makers to encourage channeling money and resources towards the most promising bio-based feedstock. One major venue to explore is the potential utilization of available marginal land to cultivate dedicated energy crops which can be used to produce biofuels. Unlike the previous two scenarios (thermochemical and biochemical conversion processes), this is a hypothetical plan that can be utilized by growers to identify the potential to enhance a profitable scenario. A case study is performed in the Jackson Purchase region to

examine the utilization of marginal land and its impacts on the economics of an existing biorefinery.

#### **5.2.4 Exploring the Integration Possibilities**

The model developed can to be used by various stakeholders from diverse professional backgrounds. Hence, one of the major attributes is its usefulness and the potential to be integrated with existing tools and novel research outcomes. The model is formulated as a collection of multiple stand-alone simulation and optimization models, each of which have a dedicated Visual Basic® interface. While this trait has been significantly explored for the data transfer, in the future, it may serve as a venue for automation and integration.

Also, for the process optimization models there are several ways to incorporate the experimental outcomes that have been determined and applied to the existing models. While such integration possibilities have been present for years, the linking of these to the process models, followed by interfacing it with supply chain models and finally, the creation a decision support tool portrays the true vision of PSE applications. Chapter 8 elaborates on the opportunities for integration of the decision support tool.

### **5.3 Conclusions**

In summary, various proof of concept studies demonstrating the working of the framework are planned. The following chapters expand on each of the schemes for biorefining discussed above. Finally, all these scenarios are compared, leading to conclusions in determining the most economically viable process in the Jackson Purchase region. This exercise not only demonstrates the capability of the framework but will also validate the potential of any process in a given region of interest.

## **6. Economic Assessment of Thermochemical Conversion Process- A Case Study on Biomass Gasification**

The contents of this chapter are adapted or taken directly from *Clean Technologies and Environmental Policy*, Volume 16, Issue 6, S. Sukumara, W. Faulkner, J. Amundson, F. Badurdeen and J. Seay, “A multidisciplinary decision support tool for evaluating multiple biorefinery conversion technologies and supply chain performance”, 2013, pages 1027-1044, with kind permission of Springer Science and Business Media.

### **6.1 Summary**

Lack of a region specific flexible optimization model poses difficulties for stakeholders, like, policy makers, growers and investors to make informed decisions about the economic viability and, social and environmental impacts of biomass utilization. This novel application illustrates an approach to develop a region specific optimization model which links various aspects of the biofuel supply chain, such as, feedstock source location, upstream and downstream logistics, as well as thermochemical processing. The research shows how various individual optimization models can be combined, resulting in a complete, multivariable economic optimization model for a regional biomass network, paving a pathway for future work to develop an integrated framework for sustainability. This chapter explains the development of a model that can form the basis of a generalizable decision support tool which can guide investors and policy makers in making critical assessments on a local level in any particular region of interest. As a proof of concept, a portion of the described model is validated for its application to evaluate the viability of biomass gasification in the Jackson Purchase region of Western Kentucky.

## **6.2 Introduction**

Recent research focuses on developing a sustainable source of energy and transportation fuel. Among the various options available, biomass intrigues many researchers because of its widespread availability, cost effectiveness and its applicability as a sustainable energy source. As described previously, the focus of biorefining research has shifted from first generation biofuels, derived from plant sugars and oils, to second generation which are produced using lignocellulosic biomass [160]. Numerous processes are available to convert lignocellulosic biomass to various marketable products; however, most of these involve extensive processing. Hence, the economic, environmental and social challenges need to be understood and overcome in order to compete with the comparatively low prices of fossil fuels [161]. Unfortunately, policymakers and investors still lack tools which can estimate the economic viability of a biorefinery that meets the needs of many stakeholders. The main focus of this chapter is to evaluate the economic viability for the process of biomass gasification, which is an essential step to validate the derived biofuels as a sustainable source of energy. In order to demonstrate its applicability, a case study is performed in the Jackson Purchase region, which has ample access to coal, waste forest matter and agricultural residues, like, corn stover and wheat straw [153]. This work sets a foundation to allow future integration of economic, environmental and societal aspects by capturing the uncertainties involved in sustainable biorefining and supporting supply chains.

## **6.3 Background**

Among the many advantages of lignocellulosic biomass, it is the expanded choice of feedstock that makes it favorable for producing biofuels and energy [10]. There are many ways in which biomass can be converted into various fuels and chemicals. Integrated biorefining is one such idea where potential feedstocks can be

converted into transportation fuel, energy and other synthetic chemical products utilizing thermochemical and biochemical techniques. In many ways, integrated biorefineries are similar to existing crude oil refineries. However, in order to be applied to biomass, the use of feedstock and production economics needs to be optimized [162].

Figure 6.1 (a concise version of Figure 2.1) shows various pathways for integrated biorefining involving multiple feedstock to produce end products. Every pathway shown from feedstock to end product has a unique supply chain and associated economic, environmental and societal impacts. Moreover, availability and quality of lignocellulosic biomass changes from one region to another. This non-uniformity makes it challenging to determine the most profitable pathway among the existing options. In addition, seasonal variability in local feedstock, environmental impacts caused by the conversion processes and the demand for marketable products cannot be overlooked while modeling [90].

Aiming for sustainability in terms of energy and fuel, it becomes critical to meet the rising estimates. However, there exist many uncertainties involved in creating biofuels from biomass compared with conventional fossil fuels. Varying seasonal availability, geographical constraints, biomass supply and biofuel demand are the major factors amongst many, causing this uncertainty [163]. As a result, one or more of the processing pathways, shown in Figure 6.1, may lead to an unsustainable supply chain. An optimization model is presented [164], that intends to capture uncertainties and determine an optimum network along with critical parameters for integrated biorefining. In order to offset any unsustainable scenario in the supply chain, local policies will play a major role [165].

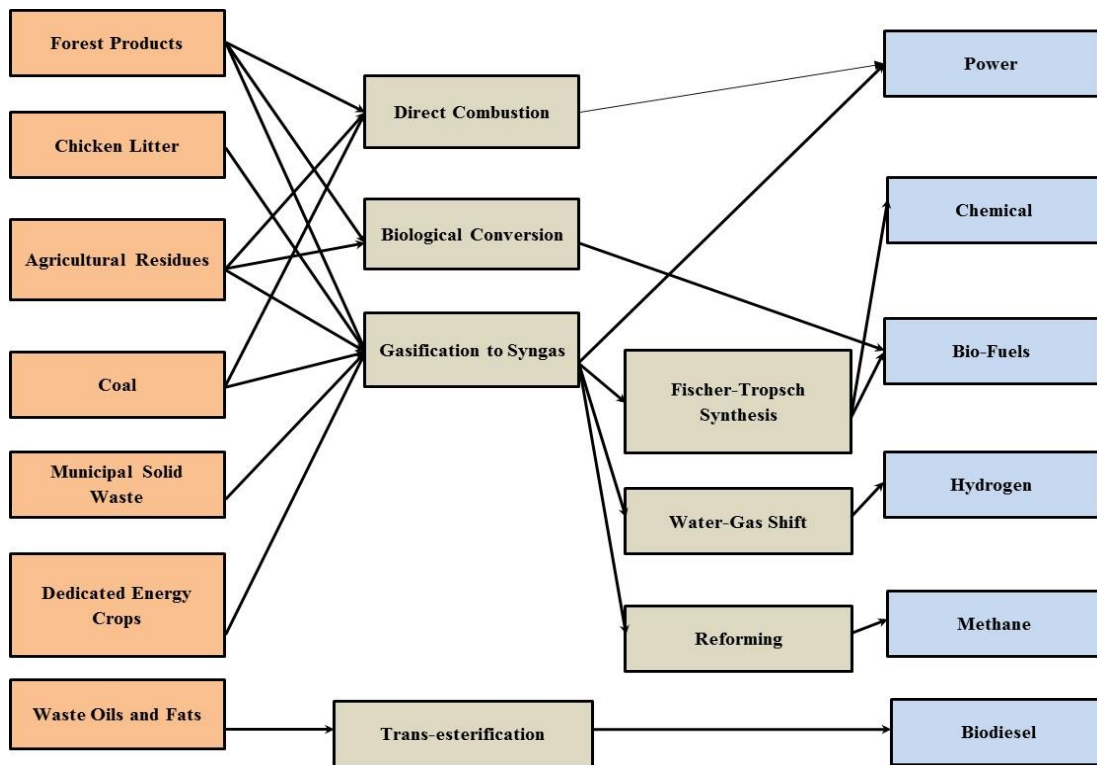

Figure 6.1 Potential pathways for integrated biorefining [21, 102]

Policies set by the government will have a great impact on the sustainability of any particular process and will affect the decisions made by local growers and investors. Governments in the past have set several direct policies, like, tax exemptions, mandatory blending requirements, renewable portfolio standards and also indirect ones, such as, carbon taxes, farm, trade and vehicle policies [165]. Nevertheless, in order to support this process, policy makers need to have a tool that can promptly and precisely measure various proposals and corresponding impacts due to any specific or combination of multiple process and policies.

There are several factors that need to be considered in order to estimate sustainability of any biorefining process. With ongoing research, as the latest biomass conversion techniques are included into the list of potential processes for the future, the complete supply chain starting from biomass in the field to distributed end products cannot be ignored. Currently most of the biorefineries focus on ethanol production and

hence are concentrated in corn producing locations. As various other promising feedstock (mainly second generation lignocellulosic feedstock) are accommodated, many other locations may have the potential to serve as a better biorefinery site in long-term. Demand is another key issue that needs to be addressed. Figure 6.2 shows the current demand, various feedstocks and existing biorefinery locations [166]. If all the maps in Figure 6.2 are combined, the future scenarios will indeed be very complicated. The addition of coal, dedicated energy crops and other first generation biofuel feedstocks will further complicate the decisions that need to be made for integrated biorefining in any particular region.

The frameworks developed previously are promising and have shown diverse details pertaining to the economic validation of cellulosic biofuels. Chapter 2 has summarized detailed contributions of contemporary research in this field of engineering. However, all the previously mentioned models either depend on other models for specifics related to process conversion or transportation details or both. The model presented as a result of this research aims to create a framework which includes all the stages involved in producing transportation fuel and energy from biomass. The unique approach suggested combines both simulation and optimization tools to readily provide data that trickles to various linked models and eventually is used to optimize the overall process of integrated biorefining. For the initial analysis, a simplified supply chain model is utilized. The model presented in this manuscript combines various techniques of process optimization from previous research in this field [74]. Other critical decisions, like, optimum biorefinery location [44] are some of the essential information that the developed economic model provides.



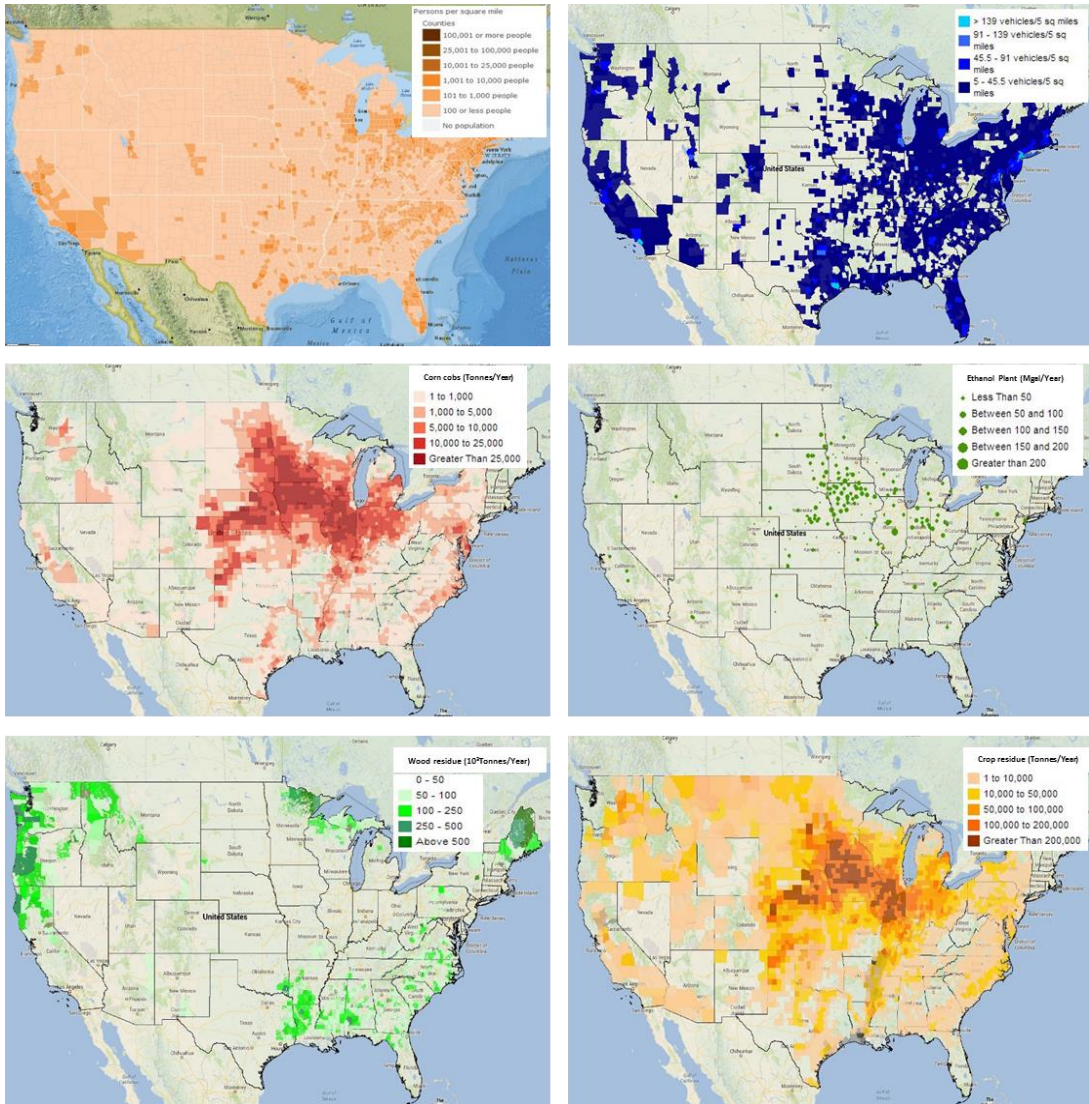

Figure 6.2 Map showing population density [167] (top left), vehicle density (top right), corn locations (middle left), existing ethanol refineries (middle right), wood residue (bottom left) and crop residue (bottom right) locations of USA [21, 166]

Note: Vehicle density (top right) shown in the figure is based on diesel, electric and flex fuel vehicles. Wood residue (bottom left) consists of forest residue and primary mill residue. Crop residue (bottom right) consists of corn stover, wheat straw, rice straw and barley straw.

## **6.4 Multidisciplinary Methodology in Developing Region Specific Model**

In order to create a working framework, the methodology proposed in Chapter 5 is implemented in a case study as a proof of concept in the following sections. The primary action required for estimating the economics of a biorefinery is to determine the largest feasible capacity. This is achieved by calculating the gate energy needs at the biorefinery (as described in section 5.1). Based on the capacity of the biorefinery, potential biorefinery locations and the biomass feedstock, an optimum transportation network is determined. The MILP optimization model is developed to identify the optimal biorefinery location and allocate transportation pathways for feedstock from its source to the biorefinery location [168]. Optimum transportation cost is one of the major outcomes of this MILP optimization model that needs to be combined with chemical conversion cost to predict the total variable operating cost for a biorefinery. However, there are many other uncertainties that cannot be ignored in the decision making process. For this reason, supply chain optimization alone is not sufficient. Supply chain simulation [89] capable of providing information about the long-term robustness of the biorefinery and its supply chain under uncertainty should be included within the modeling framework. Additionally, methods of supply chain risk management should be employed to quantify and mitigate the risks associated with this uncertainty. A Bayesian based approach [169] will be used in the future to compliment the current research for sustainable biorefining. This approach encompasses uncertainty factors, like, seasonal variation in biomass availability, hike in diesel price, lack of preprocessing, increased labor costs, decreased labor availability etc. The extended study will provide valuable insight for the development of feedstock availability distributions for use in supply chain simulation.

The next step, is to develop multiple process simulation models for various conversion processes possible in the region as shown in biorefining pathways in Figure 6.1. Conversion process can be mainly categorized into two types: The processes which are feed specific, for example enzymatic processes and the other being the processes that have the ability to include more than one biomass feedstock, for example biomass gasification. A feed flexible process simulation model followed by optimization of conversion process for maximizing profit is then developed. Critical information, such as, operating cost, optimum feed, optimum products and emissions are some important outputs amongst many from this model that capture variabilities possible in the supply chain. Capital cost is another major result that leads to conclusions related to investment in any particular process. The details pertaining to the development of the process optimization models is presented in section 4.2.2. Once the model is checked for the operating profitability, the capital cost is estimated and MILP optimization model is run including the annualized capital cost factor. The analysis presented here focuses on showing, how the effect of uncertainties involved in production of biofuels may change crucial investment decisions, like, variable feed cost, variable operating cost, fixed capital cost and net cash flow. The models developed as a result of this research can eventually be expanded in order to assess not only capital cost but also other environmental and societal impacts.

Finally, the output is checked for profitability based on some critical decisions, such as, the potential biorefinery location and most profitable feed ratio. If the results show negative cash flow, then the biorefinery capacity is reduced and the same procedure is repeated until the model shows an operating profit. Figure 6.3 provides a detailed schematic for the data exchange from one model to another. This is a short version of the framework presented in the section 4.4, as this contribution focuses on

the development of the process optimization model. The overall framework consists of various optimization models; hence data exchange between them is a major challenge. The model developed utilizes Microsoft® Visual Basic (VB) for Applications for efficient data transfer. With the help of a case study, application of the novel multidisciplinary optimization framework is illustrated. The case study does not include all the details represented in the Figure 6.3 but shows some key findings that can be achieved. For instance, iterations are performed in the case study involving process simulation and supply chain optimization. Currently, this does not include discrete event simulation in determining the optimum configuration. Subsequent chapter will include the discrete event simulation model in determining impacts of variability occurring in the supply chain.

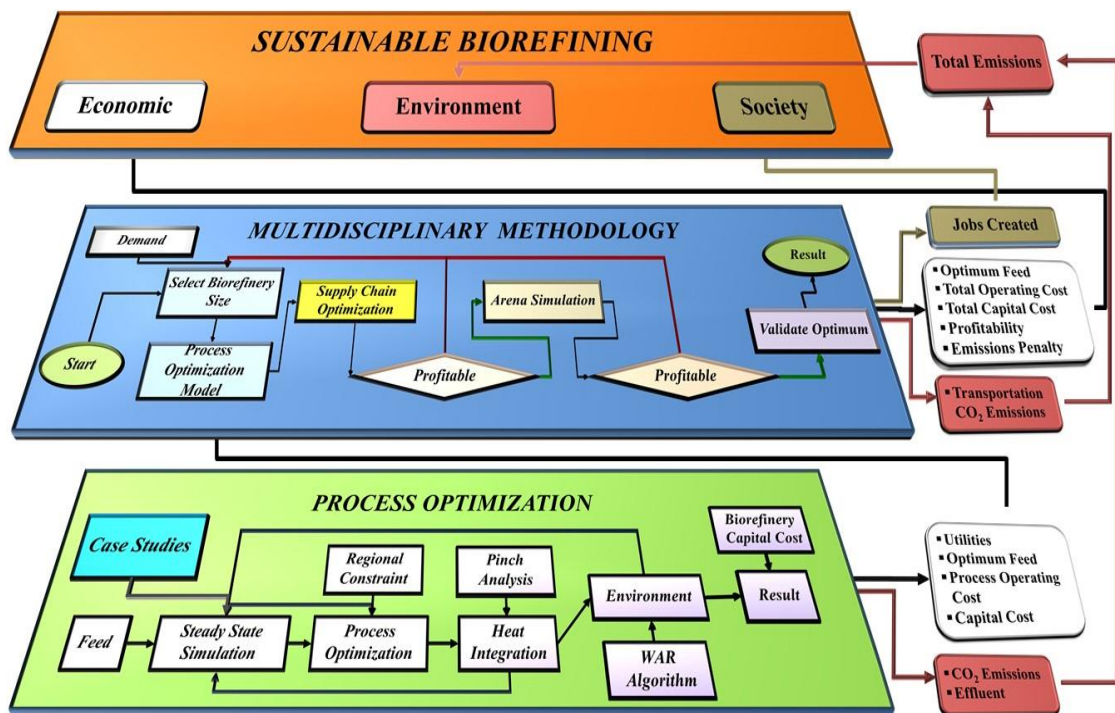

Figure 6.3 Overall framework showing multidisciplinary methodology to estimate various factors for sustainable biorefining [21]

The model developed is flexible and allows additional specifics to be added to each stage in order to achieve diverse results. This is an important feature of the methodology which is adapted due to the different stakeholder demands and local policy variations in different regions. It should be noted that a complete life cycle analysis (LCA) is beyond the scope of developed framework, however, it can act as a tool to assign weightage and share particulars with various LCA models.

## **6.5 Case Study**

The Jackson Purchase region of Western Kentucky serves as the geographic location for the case studies to be performed. A detailed description of the topography, feedstock and corresponding sites to be involved in the case study is provided in section 5.1. The following case study illustrates the development and implementation of the proposed framework; as a result there are many assumptions that go into this model. Major ones being:

- Each county has one potential biorefinery location based on the existing road network
- Preprocessing of biomass is performed at the biorefinery site
- Products are transported to a nearby storage depot. Detailed end user distribution locations are not included in the supply chain.

Figure 6.4 shows the methodology in which the data exchange takes place between the process and supply chain model. The model presented in this case study neither accounts for the detailed distribution of the end products nor does it account for the seasonal demand variation of such products. Instead, a feedstock portfolio is created based on the gate energy needs as explained in section 5.1. For simplicity, it is assumed that all products are consumed near the biorefinery location. Presently, the case study

focuses on multiple feedstock gasification of biomass to create both power and transportation fuel. Adding to previous research work [90], the results presented here takes into account the project's capital cost in the decision making process. Subsequently, the model is used to calculate the net cash flow based on variable operating costs and capital investments in various stages of the biomass conversion process and overall supply chain. This framework allows other possible potential processes, such as, biochemical conversion involving various crop residues and dedicated energy crops, making it an ideal place for the researchers and other decision makers to compare results for multiple processes.

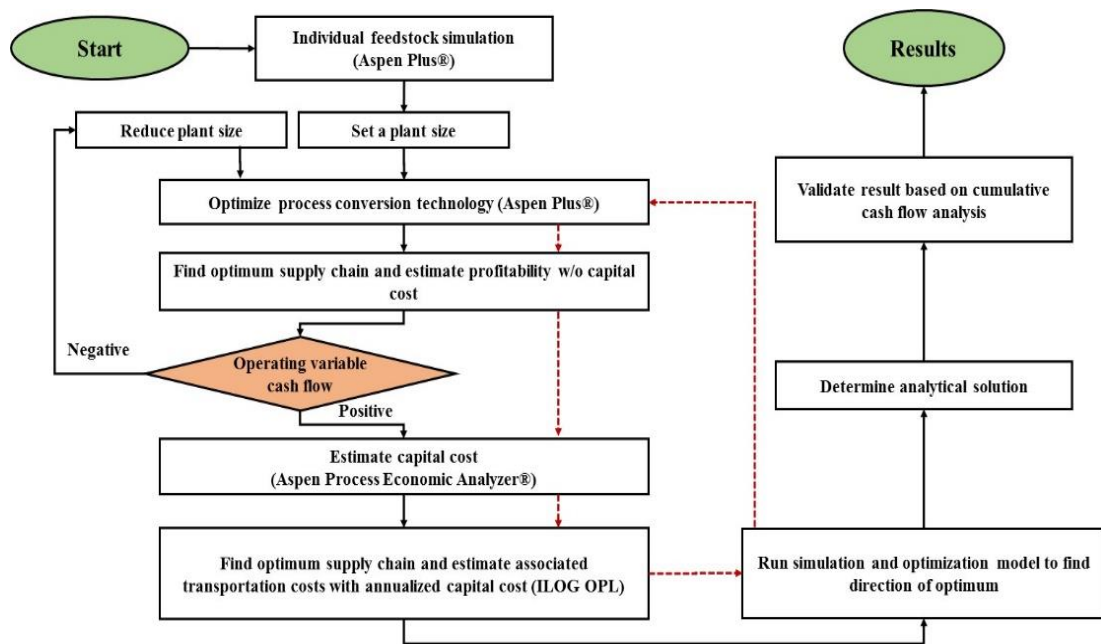

Figure 6.4 Optimization methodology used for the case study

### 6.5.1 Feedstock Location Assessment

Corn stover and forest residue are the two major lignocellulosic biomass resource available in the Jackson Purchase region. Cultivation of corn is one of the major occupations in the region and as a result, a large volume of corn stover is left behind after harvesting. In addition, every year the U S Forest Service personnel in the

adjoining Land Between the Lakes National Recreational Area trim trees to mitigate the risk of forest fires. This region is home to hundreds of poultry farms, which discards tons of chicken litter as a waste.

Chicken litter has a high calorific value and can be used for co-firing in a biorefinery. All these feedstocks are generally waste products, thus the introduction of these to the biorefinery would also provide farmers with an additional source of revenue. The locations of various feedstocks are determined using GIS and other tools, like, Google Maps®. Once the feedstock locations are determined, the nearest point on the road network is mapped and this point is assumed as the source of feedstock for calculating transportation cost. Figure 5.1 shows the local feedstocks and the potential biorefinery locations on the Jackson Purchase region map based on the existing road network.

### **6.5.2 Optimization of Transportation Network**

The low energy density of biomass makes transportation cost a key contributor in the overall economics of a biorefinery [38]. Seasonal variability in the available biomass feedstock adds to the complexity of determining the transportation network and potential biorefinery location. A MILP optimization model using ILOG OPL® is developed which takes into account biomass purchasing, handling, truck, diesel and operating costs for the siting of a multi-feedstock biorefinery location, as described previously [90]. Data, such as, potential plant locations, feedstock locations, monthly biomass/feedstock availability at each location and biorefinery size are inputs for the optimization model. The model for the Jackson Purchase region considers 19 chicken litter locations, 31 corn stover locations and 24 forest residue locations, as well as 8 potential biorefinery site locations. The MILP model determines the optimal biorefinery location and monthly feedstock portfolio based on minimizing the total cost

for transportation. The model takes 17 s to run on a computer with an Intel® Core Duo 2.00GHz processor and 4 GB RAM.

The monthly biomass availability at each location is divided into two categories; newly available feedstock and feedstock surplus. The feedstock surplus is defined as the amount of biomass not delivered to the biorefinery in a given month. For any feedstock location, the surplus will thus be stored at that location and made available in the next month while taking into consideration biological decay. This mode of operation is chosen to compensate for the seasonal variability of available biomass. Assuming the base case (100%, medium capacity biorefinery) [90], two other portfolios are derived in order to capture the behavior of profitability with changing biorefinery capacities. The large and small biorefinery is assigned a portfolio of 150% and 50% of the base case, respectively. Table 6.1 shows the various feedstock requirement portfolio in the Jackson Purchase region.

The feedstock data contained in Table 6.1 is then passed to the conversion process optimization model to determine the optimum processing cost. Appendix A.3 shows the detailed equations that was used by the MILP model as discussed in section 4.4.

### **6.5.3 Process Simulation and Optimization**

Biorefinery operating cost is another major variable cost that determines profitability. In order to find the overall processing cost, the transportation cost needs to be combined with variable biorefinery operating cost. In this case study the varying profitability for a multi-feedstock gasification process is emphasized. Later, the capital cost is estimated for various feedstock portfolios shown in Table 6.1. The framework



will also allow similar process simulation models to be created for comparing economic, environmental and societal impacts.

Table 6.1 Calculated feedstock requirement portfolio in the Jackson Purchase region

	Feedstock	August	September	October	November	December	January	February	March	April	May	June	July
Large Biorefinery Feedstock (150%)	Chicken Litter (10 <sup>6</sup> kg)	2.07	2.07	2.07	2.07	2.07	2.07	2.07	2.07	2.07	2.07	2.07	2.07
	Corn Stover (10 <sup>6</sup> kg)	13.86	14.58	15.21	14.58	15.21	15.21	11.985	13.86	13.23	13.86	13.23	13.86
	Forest Residue (10 <sup>6</sup> kg)	3.51	2.34	2.34	2.34	2.34	3.51	3.51	3.51	3.51	3.51	3.51	3.51
Medium Biorefinery Feedstock (100%)	Chicken Litter (10 <sup>6</sup> kg)	1.38	1.38	1.38	1.38	1.38	1.38	1.38	1.38	1.38	1.38	1.38	1.38
	Corn Stover (10 <sup>6</sup> kg)	9.24	9.72	10.14	9.72	10.14	10.14	7.99	9.24	8.82	9.24	8.82	9.24
	Forest Residue (10 <sup>6</sup> kg)	2.34	1.56	1.56	1.56	1.56	2.34	2.34	2.34	2.34	2.34	2.34	2.34
Small Biorefinery Feedstock (50%)	Chicken Litter (10 <sup>6</sup> kg)	0.69	0.69	0.69	0.69	0.69	0.69	0.69	0.69	0.69	0.69	0.69	0.69
	Corn Stover (10 <sup>6</sup> kg)	4.62	4.86	5.07	4.86	5.07	5.07	3.995	4.62	4.41	4.62	4.41	4.62
	Forest Residue (10 <sup>6</sup> kg)	1.17	0.78	0.78	0.78	0.78	1.17	1.17	1.17	1.17	1.17	1.17	1.17

The operating cost of a biorefinery can be divided into two categories: raw material and utility cost. The estimation of these variable costs can be achieved by running the appropriate process simulation models developed in the section 4.2.2. A steady state process simulation model is developed for the major feedstocks available in the Jackson Purchase region. The simulation model is feed flexible, as a result, it can use multiple biomass, conventional and other non-conventional feedstocks. In order to distinguish various feedstocks, proximate and ultimate analysis data [170] shown in Table 4.1 and 4.2, is used along with particle size distribution (PSD). For this case study, forest residue, chicken litter and corn stover are the major feedstocks that are included. It should be noted that the model also has the provision to add coal and/or

dedicated energy crops, like, switchgrass and miscanthus. This is an important feature as it allows local growers and investors to determine possible expansion of the local crop portfolio to include these dedicated energy grasses for improved economics.

Figure 4.7 shows the process simulation model developed for the case study. First, a steady state process simulation is developed for the feed flexible gasification [35] process. Aspen Plus® V-8.2 is the software used for modeling and process optimization. The process consists of seven major units: sizing, gasification, cleaning, WGS, power generation, FTS and product separation unit, as described in section 4.2.2.1. Sizing is a preprocessing unit where all the biomass is broken down into smaller sizes, sent through screens to get a uniform PSD and mixed before being sent to the gasification unit. In the gasification unit, for simulation purposes, all the biomass feedstocks are broken down into their respective elemental composition and then gasified in the presence of steam and air [171]. The exit stream from the gasifier consists of CO, H<sub>2</sub>, CO<sub>2</sub>, ash and trace impurities. A major portion of the impurities are tar and H<sub>2</sub>S which needs to be removed in the cleaning unit before being sent to the downstream process. Then, the synthesis gas which has an approximate H<sub>2</sub>:CO ratio of 1:1 is sent to a WGS reactor where this ratio is increased and maintained above 2:1. Finally, the exit stream is split in two: one is sent to the FTS reactor and the other to power generation. Conversions in both the FTS [134] and WGS [130] reactors are based on kinetics obtained from literature. Appendix B.1 shows process conditions in the major units of the feed flexible gasification process. Finally, the FTS products are sent to a series of two distillation columns to be separated into four assigned range of products. These products are then assigned a value for further profitability calculations.

The next step is to optimize the developed simulation model based on the regional crop portfolio, feedstock availability and multiple process constraints. The

objective function of the optimization is to maximize variable profitability as shown in Equation 6.1. Several process constraints are set in order to restrict the products out of each of the major units. The FTS products are restricted to a range of  $C_1$  to  $C_{30}$  alkanes and further divided into groups based on the composition of marketable hydrocarbons [172], such as, natural gas, LPG, gasoline, diesel and heavy oils. The output from the FTS is further separated and treated to create final products. Another constraint is set on the stream split fraction of the enriched synthesis gas from the WGS reactor, which is used to control the power and transportation fuel produced. Multiple calculator functions are present in each of the units to calculate varying consumption of process water, steam and chemicals. Finally, based on the optimum feed, a specific product slate is calculated by the Aspen Plus® process simulation. Products consisting of natural gas, gasoline, diesel, heavy oil and waxes are assigned a cost [136] from the latest available data. This costing helps to study the trend and shifts in profitability for the process. However, as discussed earlier, a constraint is set on the synthesis gas coming out of the WGS reactor to control the product.

Another constraint set on the input feed is based on the seasonal variability and uncertainties prevailing in the region. The developed process simulation model is run for optimization and the feed constraint is set to vary in a range of +/- 5% of the feedstock obtained from the MILP optimization model. This percentage of variation in biomass can be changed based on feedstock fluctuations in a given region. Also, the objective function can be readily modified for various scenarios, e.g. addition of  $CO_2$  and other effluent penalties.

## Objective Function for Process Simulation

$$\begin{aligned} \text{Maximize Profit} = & \text{Product sales (SP)} - [\text{Cost of Feed (CF)} + \text{Cost of Chemicals (CC)} \\ & + \text{Cost of Utilities (CU)}] \end{aligned} \quad (6.1)$$

Where,

$$SP = \sum_{h=1}^a C_h P_h$$

$$CF = \sum_{w=1}^b B_w F_w$$

$$CC = \sum_{v=1}^d Q_v G_v$$

$$CU = CH \sum_{x=1}^e QH_x + CR \sum_{y=1}^f QR_y + CC \sum_{z=1}^g QC_z$$

**Subject to:**

$$A = CL * O_p$$

$$D = FR * O_p$$

$$R = CS * O_r$$

$$0.9 \leq O_p \leq 1$$

$$0.9 \leq O_q \leq 1$$

$$0.9 \leq O_r \leq 1$$

$C_h =$  Price of product (\$/Gal)

$P_h =$  Product flow rate (Gal/s)

$B_w =$  Cost of feedstock (\$/kg)

$F_w =$  Flow rate of feedstock (kg/s)

$Q_v =$  Cost of chemicals (\$/kg)

$G_v =$  Flow rate of chemical (kg/s)

$CH =$  Hot utility cost (\$/J)

$CR =$  Refrigerant cost (\$/J)

$CC =$  Cold utility cost (\$/J)

$QH_x =$  Hot utility consumed (W)

$QR_y =$  Refrigerant consumed (W)

$QC_z =$  Cold utility consumed (W)

$A =$  Rate of chicken litter input (kg/s)

$D =$  Rate of forest residue input (kg/s)

$R =$  Rate of corn stover input (kg/s)

$CL =$  Generated chicken litter availability (kg/s)

$FR =$  Generated forest residue availability (kg/s)

$CS =$  Generated corn stover availability (kg/s)

$O_p, O_q, O_r =$  Multiplication factors for chicken litter, forest residue and corn stover respectively.

**Subscript Indices:**

$a =$  Number of products

*b= Number of feedstock*

*d= Number of chemicals*

*e= Number of hot utility*

*f= Number of refrigerant*

*g= Number of cold utility*

Fixed capital costs are estimated for the three capacities of biorefinery. Aspen Process Economic Analyzer® is used to size and estimate the detailed capital, labor, maintenance and plant overhead costs. Appendix B.2 shows the detailed project costs calculated for an operating biorefinery.

The process optimization model developed for this case study is one pathway among many possible in the Jackson Purchase region. Similarly, many other process simulation models can be developed and optimized for other conversion possibilities in the region. Another benefit of the proposed methodology is that it is an ideal platform to compare various preprocessing techniques and its effect on the overall profitability and environmental impact. An additional feature of this approach is that the process simulation can be further developed to monitor various effluents and greenhouse gases produced by each process.

#### **6.5.4 Overall Economic Optimization**

The various models developed must be able to transfer data in order to optimize the overall economics of a biorefinery. Both OPL® and Aspen Plus® (Aspen Technology®) have a dedicated interface with the Microsoft® VB application which can be developed in the future to communicate among various models automatically. The final goal of the combined model is to calculate the overall profitability which can

be compared among several feasible conversion processes in any given region. In this case, a proof of concept is demonstrated by analyzing one conversion technique amongst many available in the Jackson Purchase region. Raw materials for these processes are biomass and animal wastes, which currently have a very low cost but will potentially rise if this idea of integrated biorefinery is implemented. For the initial assessment, the feedstock costs have been assigned values from literature [22].

In order to perform the optimization, various critical contributors of supply chain are included. Previous analysis [22] takes into consideration all the major factors influencing the projects profitability as shown in Equation 6.2. The model used to calculate costs, like, labor, supervisor, maintenance and plant overhead cost are based on fractions of operating cost. This model is modified to include dynamic and more realistic details from the Aspen Process Economic Analyzer® to replace these fractions. An annualized capital cost is calculated and added to the existing model to determine the most profitable biorefinery location in the region. The outputs from the process and transportation optimization models are combined with the annualized capital cost, raw material cost and product sales revenue to estimate overall profit as represented in Equation 6.2. Appendix A.3 shows the detailed mathematical representation of this equation along with all the constraints, decision variables and parameters.

#### Overall Objective Function

$$\begin{aligned}
 \text{Maximize Profit} = \text{Sum}_{m=1..12} [ & \text{Monthly Product Sales}(\text{Sales}_m) - (\text{Monthly biomass} \\
 & \text{purchasing cost}(\text{BC}_m) + \text{Monthly biomass inventory cost}(\text{BC}'_m) + \text{Monthly biomass} \\
 & \text{transportation cost}(\text{BC}''_m) + \text{Monthly cost of diesel to transport the biomass}(\text{BC}'''_m) \\
 & + \text{Monthly operating cost}(\text{OC}_m) + \text{Monthly product transportation cost}(\text{PC}_m) + \\
 & \text{Monthly product transportation diesel cost}(\text{PC}'_m))] \quad (6.2)
 \end{aligned}$$

The objective of this case study is to show, how various optimization models can be combined together to develop a tool that can encompass many critical results. The key outcome of this work is that by the addition of various processes and corresponding details, the novel framework can be used to answer many policy questions related to environmental impact, jobs created and other factors determining the feasibility of sustainable biorefining in a region.

## **6.6 Results and Discussions**

Data from the detailed supply chain and process optimization models are combined to obtain vital information regarding the overall process logistics and economics. The upstream supply chain optimization model is set to maximize profitability and hence three potential biorefinery locations are suggested for various capacities in the Jackson Purchase region. Figure 6.5, 6.6 and 6.7 depicts the various locations of the potential biorefinery for small, medium and large capacities, respectively. It is observed that the small and medium biorefinery locations are most profitable in Carlisle county, where as the large biorefinery is showing better profits in Hickman county. Diesel cost is determined to be the most sensitive variable within the model. This is due to the number of trucks needed to transport the required feedstock to meet the biorefinery needs.



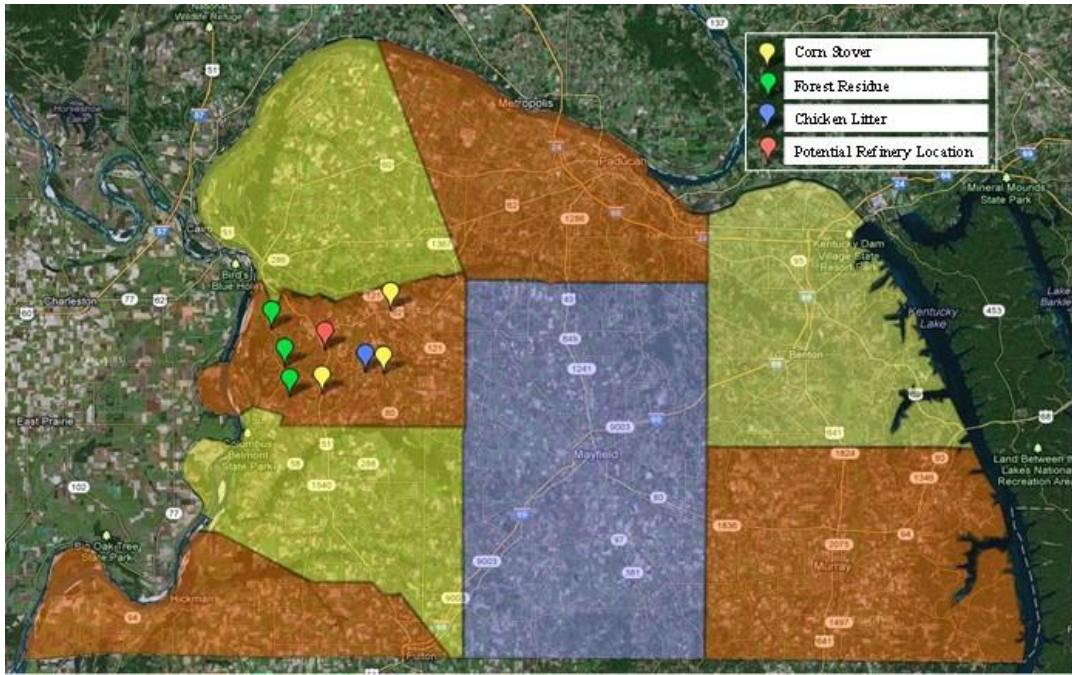

Figure 6.5 Potential biorefinery location for small capacity estimated from the optimization model [154]

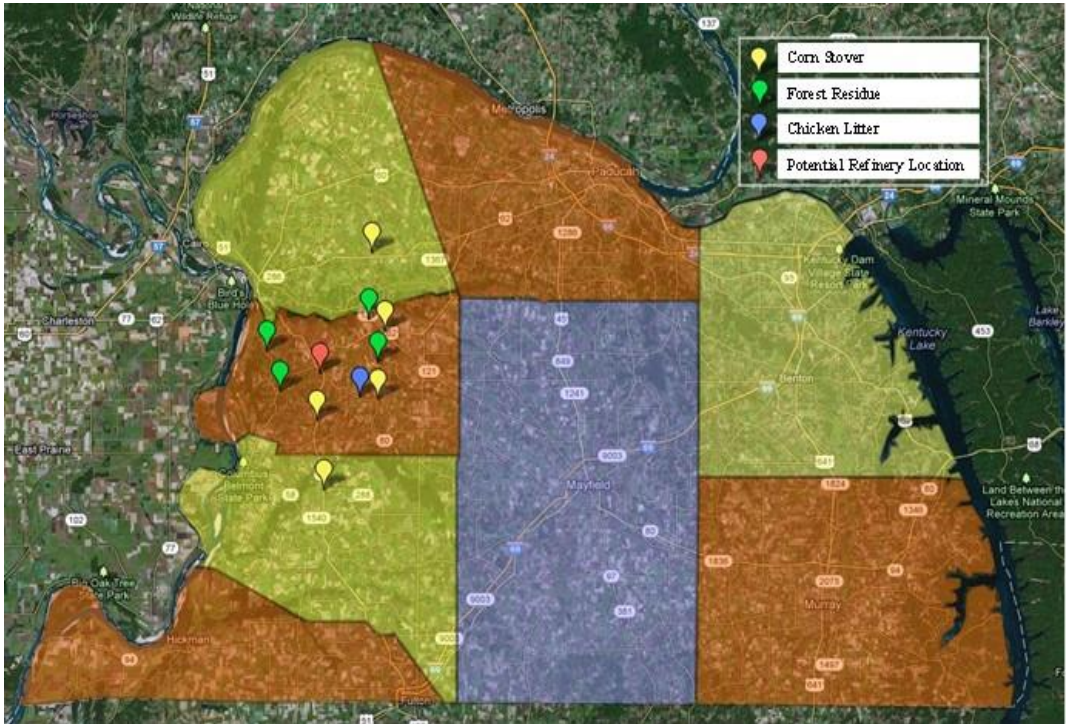

Figure 6.6 Potential biorefinery location for medium capacity estimated from the optimization model [154]

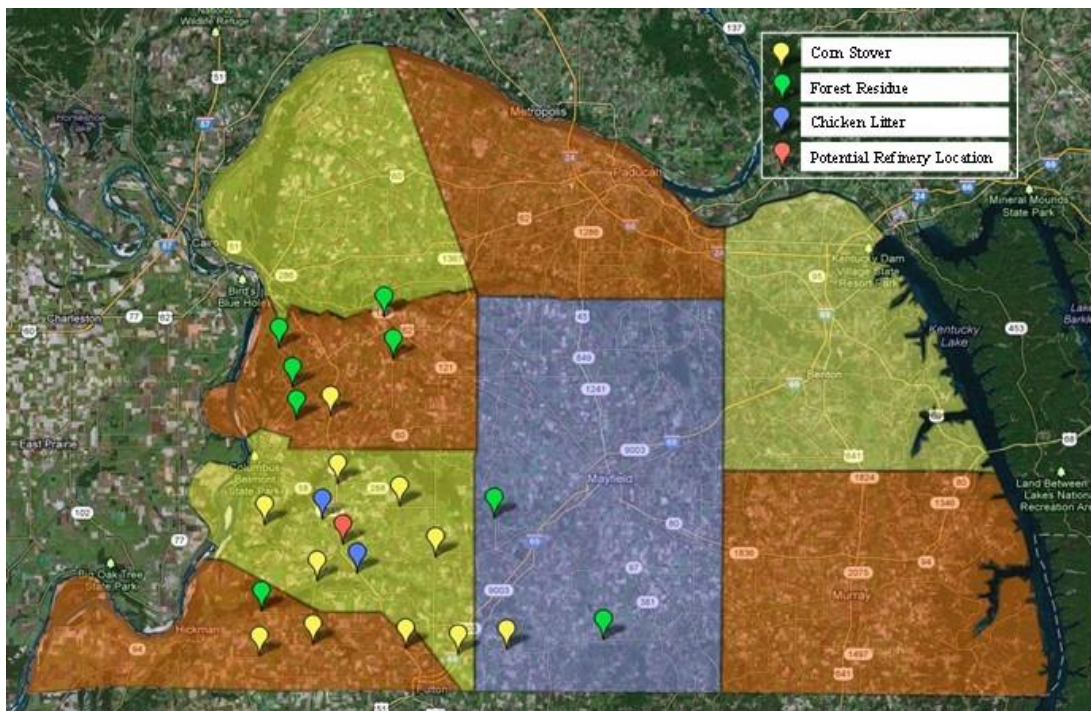

Figure 6.7 Potential biorefinery location for large capacity estimated from the optimization model [154]

The analysis is further advanced in order to evaluate various investment parameters involved for the three biorefinery capacities. Figure 6.8 shows the fixed capital costs for various capacities, considering 100% as base case. Subsequently, results from Aspen Process Economic Analyzer®, Aspen Plus® and ILOG OPL® are gathered to perform a complete cash flow analysis. This is performed for a biorefinery assuming an operating life of 10 years and a salvage value of 20% of the initial investment. In order to capture the increasing value of various commodities that are consumed and produced by the biorefinery, specific percentage increases in value are considered for each year. Products are assumed to increase in value by 5% each year, whereas utility, feedstock and maintenance costs are assumed to increase by 3%, 3.5% and 3%, respectively. Appendix B.3 (a) and (b) shows detailed variable feed and utility



costs, respectively. Based on the assumptions discussed, a cash flow analysis is estimated as shown in Figure 6.9. For the medium biorefinery the net cash flow is positive and progressively increasing. However, the small and large biorefineries initially have a negative cash flow but increases gradually.

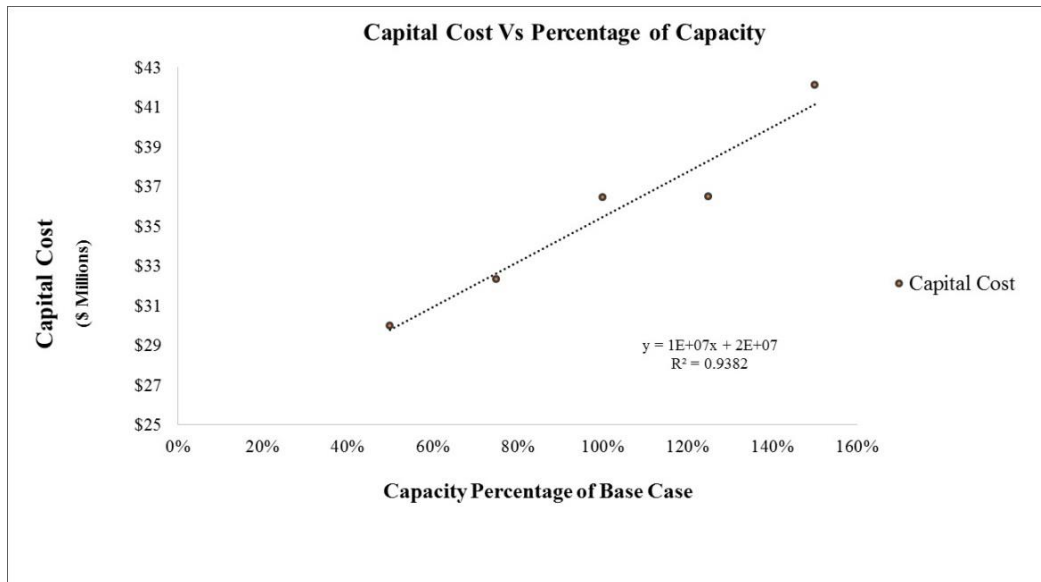

Figure 6.8 Estimated fixed capital cost for various biorefinery capacities

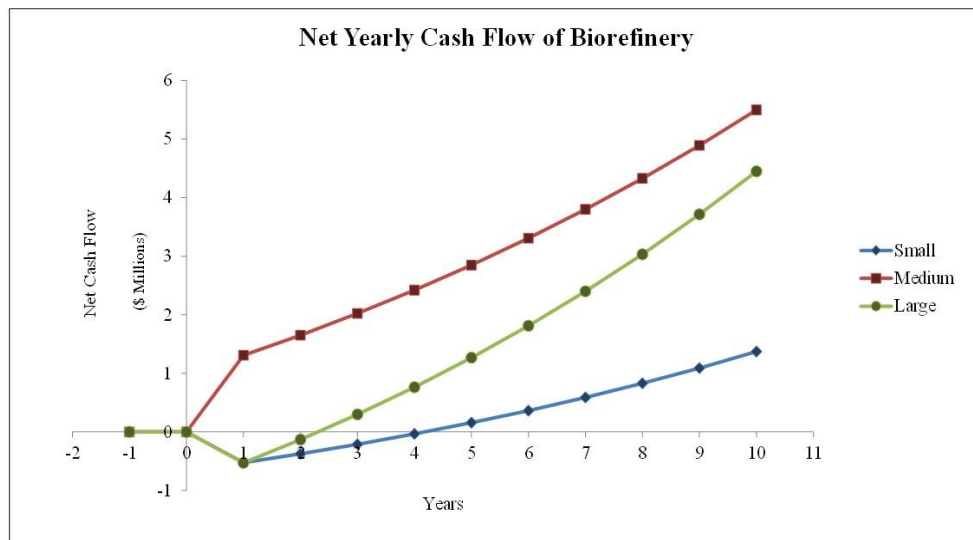

Figure 6.9 Annualized cash flow analysis for small, medium and large biorefinery

According to the results obtained, an early conclusion would be that the medium biorefinery makes a higher operating profit. Two major contributors to cash flow are revenue generated by the products and feed cost which is mainly dependent on transportation logistics. The results show that the medium scale biorefinery is making profit but as the capacity of the plant increases the share of feedstock also increases significantly bringing the cash flow down, which is due to increasing diesel cost involved in transportation [22]. These region specific results clearly show value in their ability to inform local stakeholders, further demonstrating the advantage of this approach over large scale models.

In order to state that a conversion process is profitable in the long-term and to find out the future capital cost recovery for each capacity, a cumulative analysis is required including the capital cost. Figure 6.10 shows the cumulative cash flow analysis of small, medium and large biorefineries. As with the preliminary conclusion discussed, the medium biorefinery shows better cost recovery than the large and small. It can be also noticed that the small biorefinery is burdened with the capital investment and hence may take longer period to recover amongst the three.

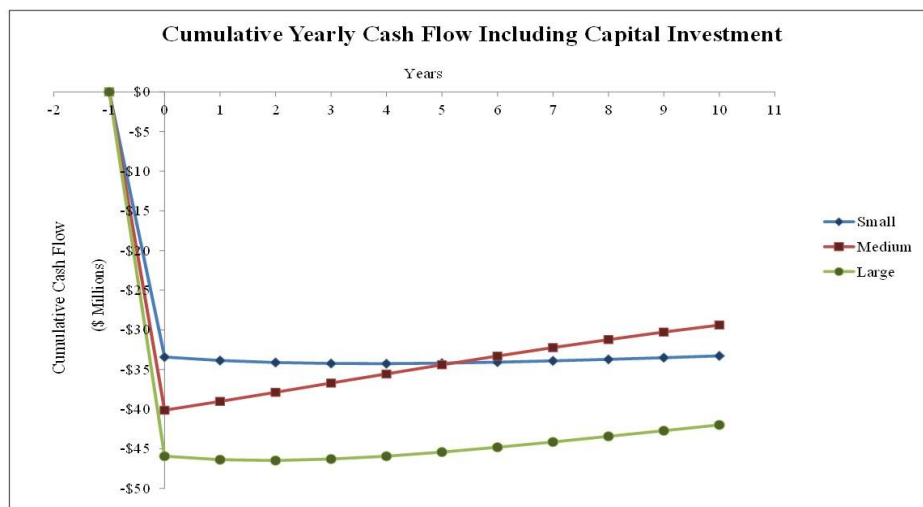

Figure 6.10 Cumulative cash flow analysis for small, medium and large biorefinery

Finally, the analysis will not be complete without predicting an optimum operating capacity for a potential biorefinery in the region. Based on the results obtained, net present value (NPV) for the respective biorefineries are calculated and a theoretical optimum is obtained at 96.1 % of the base capacity. Figure 6.11 graphically shows the shape of the curve that is calculated to predict the optimum capacity. However, it needs to be kept in mind that the addition of more intermediate results may change the nature of the curve and consequently the optima. In order to validate the calculated optimum configuration, cumulative cash flow analysis are performed at 95% and 105%. Appendix B.4 confirms that the most favorable cash recovery happens between 95% and 100%, hence justifying the claim.

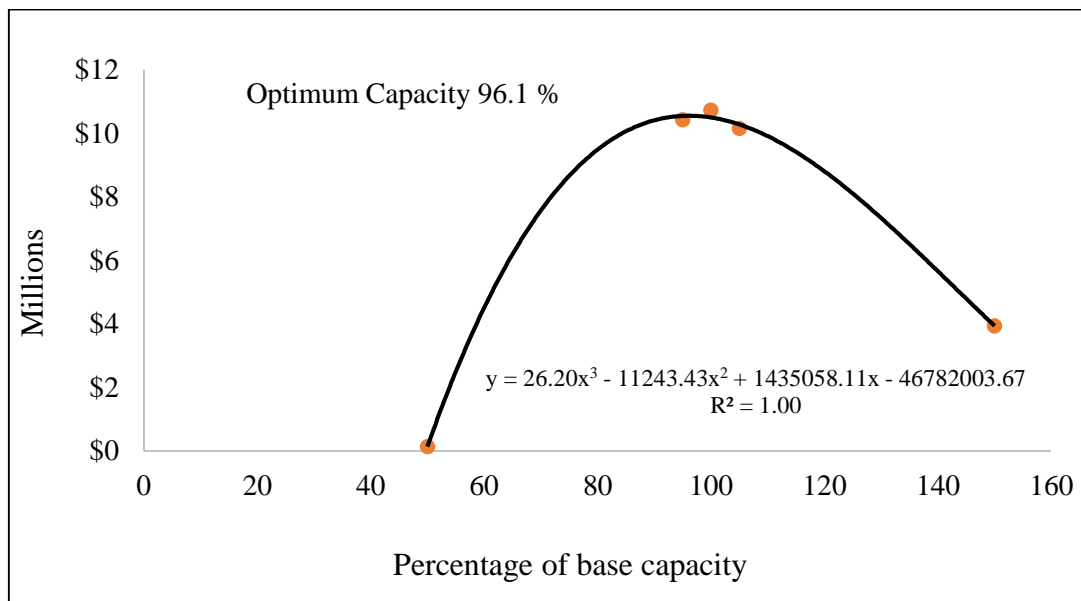

Figure 6.11 Calculated NPV for varying capacities of biorefinery

The analysis shown here can be used to decide upon the most profitable operating mode based on changing availability and operating conditions. This decision support tool helps compare certain cases and answer questions, such as: would it be profitable to run the plant throughout the year or operate it for a shorter period and shutdown for the remainder of the time in order to avoid storage losses. Another

observation is that, for the current cost of fuels it is not possible to achieve any long-term capital cost recovery under the present economic conditions. Hence, in the future, the biofuel prices must be higher or government supported incentives should be given in order to obtain long-term operating profit. Another potential use of the model could be the analysis of the addition of dedicated energy crops, such as, switchgrass and miscanthus, to the gasification process which may mitigate any non-profitable scenario. For this purpose, marginal land available in the region can be used by farmers for cultivation.

Summarizing all the above results, it can be observed that this novel integration of feedstock assessment, supply chain optimization and process systems engineering can be used to provide better insight on variable processing cost, profitability, required capital investment, and optimum biorefinery location. Also, results obtained in the case study guides the research for its future applications in many other dimensions to answer several critical questions related to sustainability.

## **6.7 Learnings and Future Directions**

Based on the literature and results obtained, existing models must be further developed to account for various additional details. The current work focuses on one pathway for producing liquid transportation fuels and power. Similar models will be created and optimized to populate all the possible pathways for integrated biorefining. The following are the major future applications that will bring more value to the existing model.

### **6.7.1 Addition of Biochemical Process Optimization Models**

A process for biochemical conversion of corn stover to ethanol is developed for this region based on previous work by NREL [54], shown in Figure 4.14. This is a feed

specific process involving enzymatic reactions. The process is optimized to maximize the profitability of biorefinery. The conversion process includes adding enzymatic kinetics to the existing process model for estimating realistic conversion rates. Similarly, the processes of converting corn stover, wheat straw and other dedicated energy crops, such as, switchgrass and miscanthus to butanol will be developed and studied in the future. Finally, the developed models can be compared with the existing gasification model. The following chapter will expand on the development and optimization of the process simulation model for enzymatic fermentation process to produce ethanol from corn stover.

### **6.7.2 Heat Integration**

The process simulation model developed in Aspen Engineering Suite (Aspen Technology®) has been optimized for maximizing profitability; but further cost savings can be realized by performing a thermal pinch analysis. Initial assessment of heat integration for the gasification process has shown a savings of 30% in the operating cost which further justifies the argument for a potential biorefinery [21]. Cogeneration is another possibility that needs to be explored and will further contribute to savings in terms of process energy consumption, although the economic benefits must be considered along with the potential negative environmental impacts of utilizing coal.

### **6.7.3 Environmental Analysis**

Ash coming out of the gasifier often has many inorganic compounds [173] which may require processing before disposal. There are tools available to estimate the environmental impact of any process, based on the feedstock and utilities used. Inclusion of chicken litter as a feed must not be considered without a detailed ash analysis. The WAR Algorithm [91] is such a tool that can be used for this purpose. A preliminary analysis is performed based on the developed process models, shown in

Appendix B.5. The analysis conducted takes into account the process simulation part of the overall supply chain. The results tend to conclude that the gasification has significantly higher potential environmental impact compared to the biochemical conversion process. However, there may be a capital and variable operating costs which must be added to the existing costs in order to make the solid wastes disposable, which has not been considered in the present analysis. A complete analysis over the entire supply chain needs to be conducted in order to further fortify this claim. In the future, the aim of the developed framework will be to make the process results compatible to inputs of various other environmental impact estimating tools, such as, TRACI 2.0 [92] to validate processes from an environmental point of view.

#### **6.7.4 Societal Impacts**

Another major outcome that needs to be analyzed are the societal impacts. Aspen Process Economic Analyzer® has the ability to calculate the skilled manpower required to run the processing plant. There are a few dedicated models for estimating the jobs created by various processes. One such model is NREL's Jobs and Economic Development Impact (JEDI) model [93]. An initial assessment of the jobs created by the biochemical process is estimated using the JEDI model, shown in Appendix B.6. As mentioned previously, a complete analysis over the entire supply chain must be conducted which may further add to the existing jobs. However, this model supports only limited conversion techniques. In the future, this aspect of sustainability needs to be explored in order to validate applicability of any conversion process.

The case study shows that this multidisciplinary tool can give answers, such as, varying profitability, optimum feed ratio, fixed capital cost, maintenance, labor, transportation and processing cost. However, it needs to be combined with all the previously mentioned future work in order to show the feasibility of biomass as a



sustainable source of energy and transportation fuel. Figure 4.18 shows, how the present results and future work can be combined to develop a novel framework that can be used as a tool to find economic, environmental and societal impact of any bio-based feedstock for integrated biorefining.

## **6.8 Conclusions**

The results shown demonstrate how a multidisciplinary approach encompassing feedstock assessment, supply chain optimization and process systems engineering can be implemented to estimate the total production cost of energy, fuel and chemicals from various renewable resources in a specific geographic region. The aim of this framework is to test various scenarios in any given region to inform local stakeholders, but not to advocate any particular process of biorefining. The results from the case study indicate that gasification may not be a viable option in the Jackson Purchase region. However, similar studies can be performed using this interdisciplinary framework on other conversion techniques, which will validate any viable option in the region. A major advantage of this model would be its generalizability for different regions utilizing locally available resources. In the future, this model will be populated with various conversion processes and corresponding products produced to find the most economic pathway for biorefining.

This unique comprehensive approach can be utilized as a decision support tool to provide a framework by which the economic feasibility of any new bio-based resource can be determined and compared with existing technologies. The model can not only be used by investors and policy makers as a tool to estimate the monetary investment required for biorefining but will also allow any locale to attain the goal of sustainability. Progressing towards achieving the objectives, the next chapter will emphasize on the development of a biological conversion process. Additionally, the

framework will be appraised for its linking with both the supply chain optimization and discrete event simulation models.

## **7. Economic Assessment of Biological Conversion Process – A Case Study on Fermentation of Corn Stover to Ethanol**

The contents of this chapter are based on the publication (submitted) in *Clean Technologies and Environmental Policy*, "The Sustainability Nexus" special issue, S. Sukumara, J. Amundson, F. Badurdeen and J. Seay. "A *Comprehensive Techno-Economic Analysis Tool to Validate Long-Term Viability of Emerging Biorefining Processes*", 2014 (*under review*).

### **7.1 Summary**

Processing of biomass into various marketable products requires a well-planned strategy from an investment, agriculture, management and policy making perspective. The novel techno-economic analysis tool described in Chapter 4 includes multiple process and supply chain models into a comprehensive decision support tool. Incorporation of detailed upstream and downstream processes not only gives an opportunity to accommodate fundamental research, but also allows for the consideration of the effects of future uncertainties. The previous chapter focused on evaluating the viability of a thermochemical conversion process. The utility of the multidisciplinary framework is further validated by performing a case study on a biological process to convert locally available corn stover to ethanol. The results obtained show how the unique integration of process simulation, supply chain optimization and discrete event simulation can be used to validate the long-term economic viability of a biorefining process. Analysis demonstrates that the developed decision support tool can be generalized to estimate long-term economic and environmental viability of potential biorefining processes in any given region of interest.

## 7.2 Introduction

To counter the challenge of meeting the increasing energy and transportation needs, governments and private institutions around the world are funding research, on developing a stable, practical and sustainable source of energy. Developing new techniques requires scientific innovation as well as simultaneous projection and justification of the technique as a long-term viable option.

Second generation biorefining processes based on lignocellulosic biomass have emerged as a promising alternative that have a distinct advantage over other processes with the potential for inclusion of various feedstock. However, a major bottleneck for the application of the lignocellulosic conversion process is low energy density of the raw biomass feedstock. As a result, meeting the logistics challenge for the biomass supply chain is crucial in determining its long-term viability. Figure 1.2 in the Chapter 1 shows an example (in the USA) of a supply chain problem that needs to be solved in order to estimate various impacts of biorefining. In reality, with numerous feedstocks to choose from, the figure shows a simple representation of a very complicated scenario. The previously mentioned advantage of second generation biorefining conversion techniques has latent complications, arising due to low energy content and scattered supply locations. Other key challenges for biorefining include: capital investment in new technologies [174], long-term economic viability, competing with existing fossil fuels to yield products (e.g. gasoline, diesel and other liquid fuels), ensuring sufficient production of biomass to meet biorefinery feedstock demands and validating emerging processes based on its economic, environmental and social impacts. [175]. Therefore, it is critical to channel the resources to appropriate biorefining processes and equally important to accurately estimate the major impact of variability and inherent uncertainties. Hence, a framework is required that can not only guide lab scale research

by quantifying practical feasibility but also identify corresponding biomass-to-bioproducts supply chain configurations.

Presently, both the thermochemical and biochemical conversion processes include proven techniques that can be applied to any region, based on locally available feedstock and product demand. While thermochemical processes can be used for producing various liquid transportation fuels along with electricity, biochemical process can be used to produce alcohols and other byproducts. Foust *et al.* (2009) showed that both processes are competitive and the economic viability depends on the properties of feedstock available in a given region [151]. Previous research [21] demonstrated the development of a framework to determine optimum supply chain configurations and perform analyses on a thermochemical process of gasification followed by FTS. This research extends the work illustrated in Chapter 6 by demonstrating the applicability of this tool for another emerging conversion technique. The novel contribution demonstrated by this research tailors process optimization, supply chain optimization and discrete event simulation in a unique manner to determine the key economic parameters.

### **7.3 Background**

In the last decade, due to growing concerns over the future reliance on fossil based resources, research has focused on developing models to solve the complex process and supply chain logistics of biorefining. The biochemical process for conversion of agriculture residue to alcohols is a proven technique. However, in order to encourage investment in this process, several biotechnological challenges must be overcome [56]. Also, as these technologies are applied towards the development of enzymatic processes, all the uncertainties must be captured.

So far, several efforts have been made in assessing the economic viability of various biochemical processes to produce biofuels. Aden *et al.* (2002) developed a detailed techno-economic model that is supported by a rigorous process simulation to estimate the capital and operating cash flow for corn stover to ethanol conversion technique [54]. Subsequently, the report was updated by Humbird *et al.* (2011) with a few operational changes in the conversion technique [55].

Another contribution [176] developed seven process design scenarios for producing ethanol, hydrocarbon fuels and power utilizing switchgrass as a feedstock, which demonstrated comparison of various scenarios and corresponding economic outcomes. Dunnett *et al.* (2008) presented a model for optimization of bioethanol supply chains to determine the optimum logistics for multiple plant systems, considering the spatial feed supply and product demand locations [177]. Another work [178], developed a multi-objective MILP model which is optimized for economic and environmental performance for first and second generation biorefineries in Italy. The model was an extension of previous work [179] which accounts for both carbon and water footprints.

A recent review article [40] presented a comprehensive compilation of contributions in the field of biorefinery supply chain optimization, planning and determining uncertainty. Also, a detailed summary of the unique research contributions presented so far is explained in Chapter 2. All of the previously mentioned contributions are critical and focus on capturing the variability of biorefining processes. However, we still lack a tool that can link the impacts of emerging innovations to the long-term dynamic economic performance for the future. Estimating this requires a unique algorithm that is comprised of mathematical optimization models that can identify the supply chain configurations and simulations which can capture the dynamic system

performance of those supply chains. Chapter 6 demonstrated a unique linking of the process simulation and supply chain optimization model. While the model provides deterministic fixed values pertaining to the optimal biorefinery configurations, the effect of long-term variability have not been captured yet. Adding to this, interfacing these models is challenging; the method requires an iterative approach that facilitates sharing of data among the models. Recent research contributions [21, 67, 70, 82] have adopted similar concepts by integrating simulation and mathematical optimization, improving the credibility of the results. However, there is still a significant gap in research that focuses on linking these models.

The goal of this chapter is to demonstrate the functioning of the framework which can capture the impact of the dynamic variables that can affect the steady operation of a sustainable biorefinery. The framework serves as a platform for the development of a techno-economic decision support tool, which combines process simulation, supply chain optimization and discrete event simulation models. The results obtained are informative and aim to assist various stakeholders, such as, investors, growers and policy makers by providing conclusive results.

#### **7.4 Methods and Modeling Approaches**

An ideal techno-economic model must provide details pertaining to economic analysis as well as have an ability to include fundamental research outcomes. Hence, the goal of developing the framework should be to create a model that is accessible to researchers. The framework should allow them to change the technical details while providing extensive solutions and the ability to test potential scenarios and capture variability and uncertainties in the supply chain. The framework developed integrates three versatile tools to share data in a systematic manner that will be discussed in the following sections.

A process conversion model must be developed that can capture technicalities of real processes and fledgling research ideas. Various modules of the Aspen Engineering Suite (Aspen Tech®) are used in modeling and optimizing the conversion process. Steady state process simulations are developed in Aspen Plus® which focuses on the inclusion of all the mass and energy streams of a biorefinery. A previous contribution [21] illustrated the development of a thermochemical pathway for biorefining which shared data with the supply chain optimization model to estimate long-term viability of the biomass gasification process. The focus of this research is on the development of a biochemical process simulation which will be further appraised to share data with the supply chain models.

Selecting the optimal location for the biorefinery site is a major decision that can have a significant impact on the overall transportation cost and process economics [72]. A thorough literature review indicated that MILP is the most common method used to design biorefinery supply chains and determine the optimum logistics network for various conversion techniques. Faulkner (2012) presented a MILP optimization model that would determine biorefinery location and corresponding supply chain for a thermochemical and biochemical process [22]. Chapter 6 demonstrated the successful application of the developed MILP and, subsequently, its linking with the process simulation in an iterative manner to determine the optimum biomass-to-biofuel supply chain configuration.

By far, most of the contributions have limited their scope to identifying the optimum supply chain under deterministic conditions. It is necessary to account for the dynamic changes existing in the supply of feedstock and demand of end products, incorporating the effect of uncertainty in the system. In order to capture the impact of variabilities that can occur during the transportation of biomass feedstocks and end



products from the biorefinery, a discrete event simulation is coupled with the framework. Amundson (2013) formulated this supply chain simulation model which can be linked to the existing framework to evaluate long-term economic parameters of the biorefinery [89]. Figure 7.1 depicts the data inputs required and results that can be generated by the linked models.

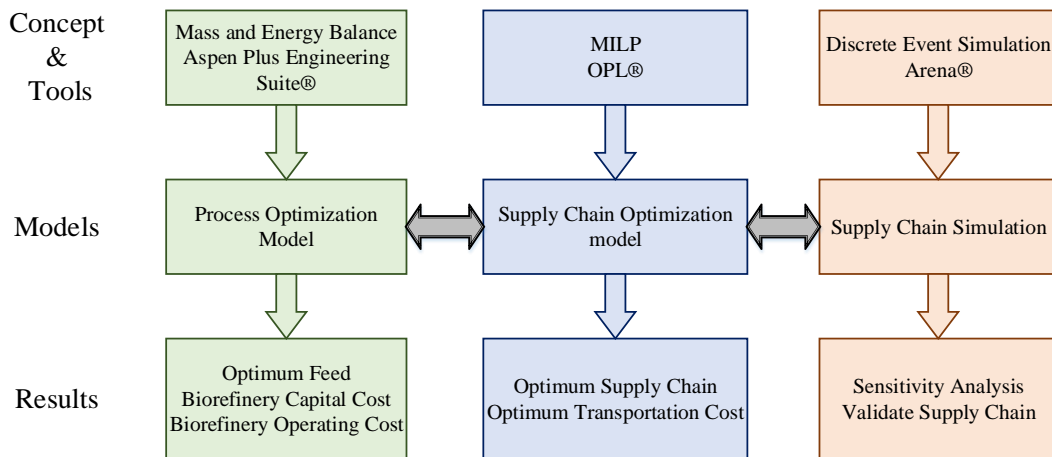

Figure 7.1 A representation of tools, models and respective results that are generated by the framework

### 7.5 Proof of Concept

The framework developed can answer various questions pertaining to the economic feasibility of biorefining processes, proving to be beneficial for stakeholders. In order to study the impact of variability on a practical scenario, a case study is framed to substantiate the working of the proposed integration. The region chosen for the study is the Jackson Purchase Region, located in West Kentucky, USA. The details for selecting the region have been discussed in previous publications [21, 22, 89]. In addition, a case study has already been performed in this region for biomass gasification in Chapter 6 [21]; hence, further exploring the region for a possibility of biorefining that facilitates the comparison of the two processes on equal grounds.

In order to analyze multiple scenarios with the previously described process conversion and supply chain models, an algorithm is developed to guide the users with a methodology of data exchange and determining optimum configuration. Figure 7.2 depicts a flowchart describing the propagation of data between the stand-alone models to determine the best operating biorefinery configuration. The major assumptions that go into the model are as follows:

- corn stover is the only feedstock that is used for the biochemical conversion process
- ethanol and electricity are the marketable products from the biorefinery
- the iteration starts with the maximum available feedstock (maximum capacity) and the biorefinery capacity is reduced as the iterations proceed until an optimum is determined and validated
- 2% of the available biomass is assumed to be degraded during transportation and in storage
- each county has one potential biorefinery and storage location, where the end product is transported
- the products are transported from the biorefinery location to the storage depot. Transportation to the end users is not considered at this point.

Additionally, each model has several inherent assumptions which are discussed in the Chapter 4. The current scope of the research is to determine results supporting economic feasibility of a biorefinery. Currently, the model does not incorporate multi-objective optimization that considers environmental and societal impacts.

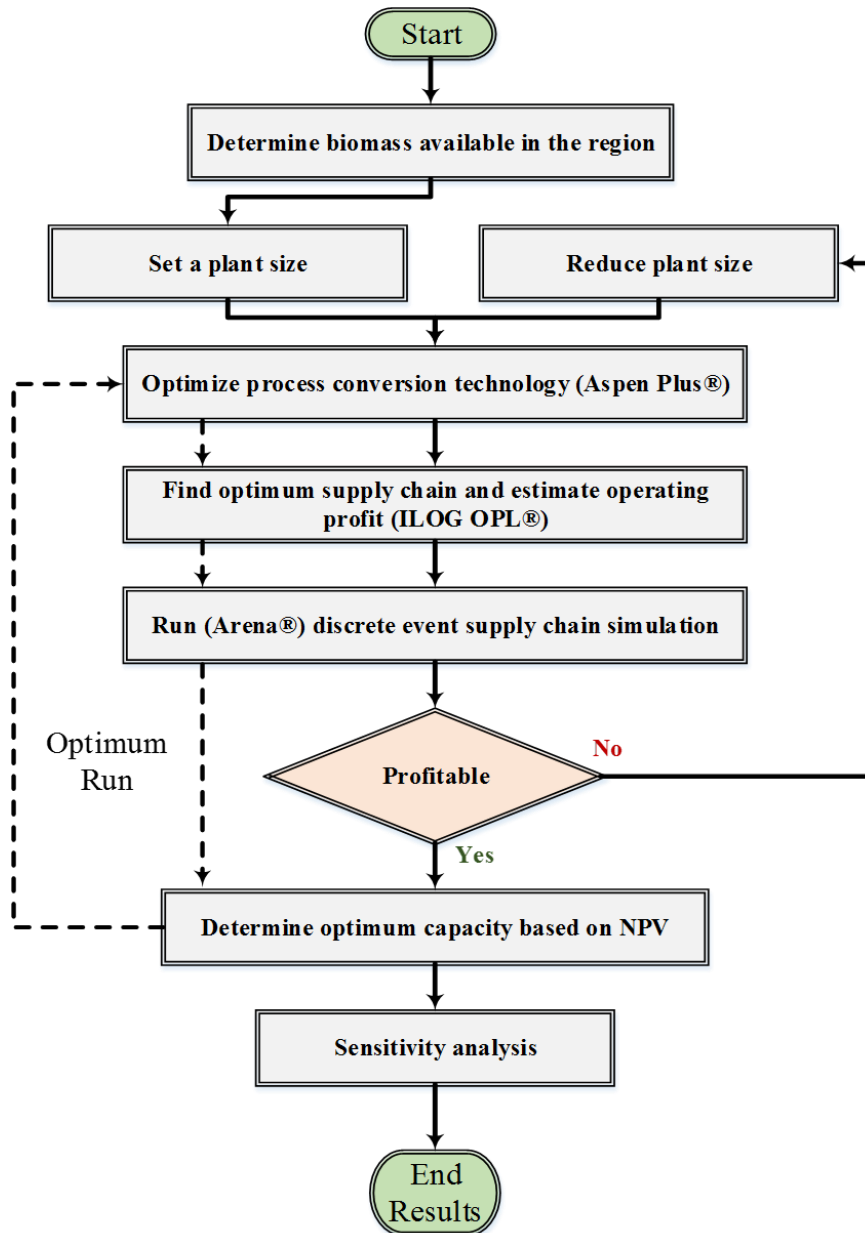

Figure 7.2 Algorithm to perform a case study in order to determine the optimum capacity

### 7.5.1 Steady State Process Simulation and Optimization Model

In order to convert the biomass into liquid fuels, a biochemical conversion pathway is adopted for this case study. The process simulation model to produce ethanol from corn stover is developed in Aspen Plus® based on operating conditions and data from the literature [54, 55]. The goal of creating the simulation is to determine

the optimum feedstock requirement, capital investment and operating costs of the process that depends on varying conditions under which the conversion takes place. The following description states various parameters and constraints that are used in the simulation. Figure 7.3 (a condensed form of Figure 4.14) illustrates the major unit operations involved in the simulation. The detailed development of the process simulation is described in section 4.2.2.2. Nevertheless, for continuity the development process is summarized subsequently.

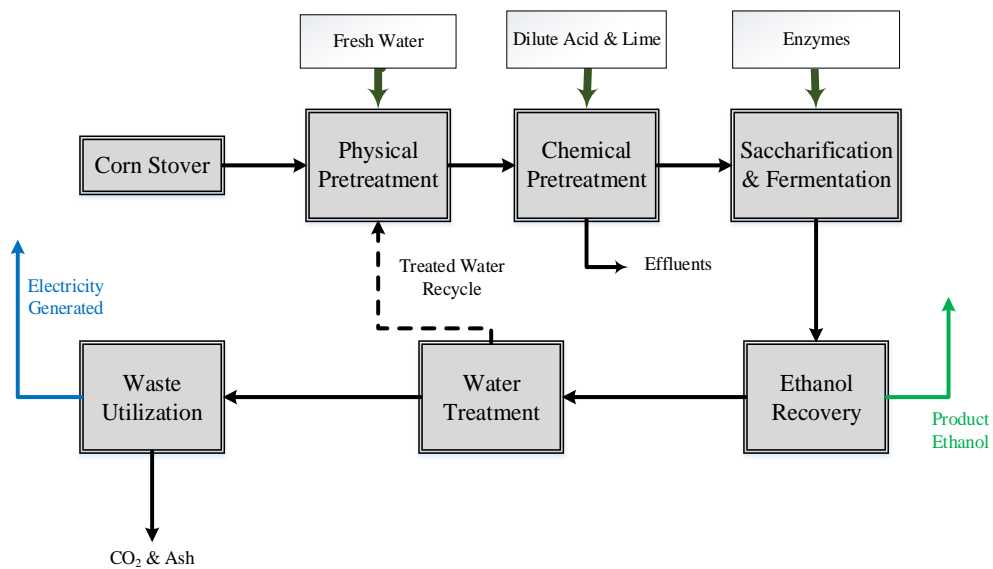

Figure 7.3 Process flow diagram for producing ethanol from corn stover

The process is initiated by defining the composition of corn stover, based on various compounds present in the feedstock. The first phase is the physical pretreatment, where the biomass is washed to remove the impurities and shredded into smaller sizes to improve efficiency for the chemical pretreatment, which is the next phase of the process. The reduced corn stover is then screened and sent to the chemical pretreatment section. In this stage, the biomass is treated with dilute sulfuric acid and steam to expose the cellulose and convert the oligomers to their respective monomers.

This process is followed by adding lime to the exit stream in order to maintain the pH before sending it to the next phase of the simulation process.

In the saccharification and fermentation section, the cellulase enzymes are added to the stream and given sufficient residence time. Here, cellulose is converted into glucose followed by fermentation of glucose to ethanol. Chapter 4.2.2.2 demonstrates the development of a simulation and provides description of the reactions involved in the process.

The outlet stream from the fermenter consists of water, ethanol, by-products and traces of unreacted sugars. This stream is directed to the purification section where ethanol is separated using a combination of distillation and molecular sieve in succession, resulting in a 99.5% pure ethanol. The effluents from the purification section is sent to the waste water treatment plant, where it is treated in anaerobic and aerobic conditions. Prior to this, the left-over solids are removed using a filter and sent to the waste utilization section, where it is combusted to produce process heat. The heat is used to generate steam which is expanded in a turbine to produce electricity.

Finally, costs are assigned to various input, output and utility streams. Subsequently, the process is optimized to maximize operating profit. Equation 7.1 shows the objective function used in determining the optima. Appendix C.1 shows detailed constraints, variables and notations used in the equation. The capital cost of the developed process is determined by interfacing the data with Aspen Economic Analyzer®. The model developed is the first step in running the framework. All the economic, feed requirement and effluent results are recorded and passed to the next step (MILP).

Maximize Profit

$$Profit = Product\ Sales\ Income\ (PSI) - Biorefinery\ Operating\ Cost\ (BOC) \quad (7.1)$$

Note: The details of the equation can be found in Appendix C.1

### 7.5.2 Supply Chain Optimization

Transportation logistics and associated costs play a major role in determining the overall cash flow of a biorefinery [72]. Hence, variables such as, feedstock availability, optimum feed demand at the biorefinery location, transportation cost (operational and diesel cost) and product distribution cost must be included in the decision making framework along with biorefinery operating cost. The data from the process simulation is used as an input to the MILP supply chain optimization model. The goal of the study is to determine the optimum supply chain and corresponding transportation cost while meeting the optimum feed demand of the biorefinery.

Figure 7.4 (derived from Figure 5.1) represents a schema of the feed location, potential plant sites and product depots on a map (Google Maps®). For this case study, the objective function is to maximize profit of the overall process. Equation 7.2 shows the objective function used to optimize the transportation logistics. A detailed description of the constraints is provided in Appendix A.3.

Objective Function

$$Total\ Profit = Summation_{m=1..12} (Sales_m - Cost_m) \quad (7.2)$$

Note: The expanded equations of the above costs is shown in Appendix A.3

The MILP model determines the most profitable biorefinery location and corresponding supply chain, with a constraint to open one biorefinery. The results from the MILP and process optimization models are combined to calculate the total variable

cost of the biorefinery. The model is valuable as it helps to identify the complex supply chain configuration; nevertheless, it is equally important to capture the volatility in the feed supply and product demand. Hence, the results obtained are passed to the discrete event simulation for further analysis.

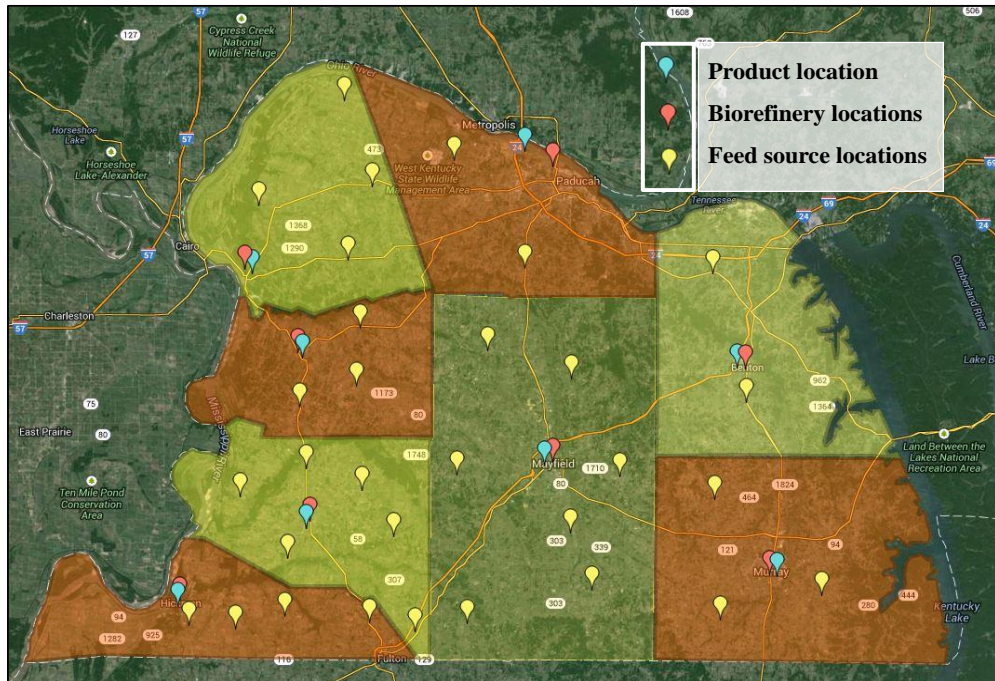

Figure 7.4 Potential biorefinery sites, feedstock and product depot locations in the Jackson Purchase region (Google Maps®)

### 7.5.3 Discrete Event Simulation Model

The model for the supply chain activities is simulated for twenty years. Various costs related to feed procurement, product delivery, sales and operation are tracked for the time period to determine the economic viability of the corn stover-to-ethanol process in the Jackson Purchase region. The model requires capital investment data from the process simulation to determine a payback period. Financing is assumed to last twenty years with a compounding interest rate of 10% per year. To properly account for the time value of money, the simulation model tracks the Net Present Value (NPV)

of the biorefinery supply chain operations. Equation 7.3 and 7.4 are used to calculate the NPV and equivalent annual payment (EAP), respectively.

Net Present Value

$$NPV = \sum_{t=0}^N FV_t / (1 + d)^t \quad (7.3)$$

Equivalent Annual Payment

$$EAP = \sum_{t=0}^N CC * \frac{r}{1 - (1+r)^{-t}} \quad (7.4)$$

Where,

$N =$  time period

$FV_t =$  future value of the cash flow

$d =$  discount rate

$CC =$  capital cost

$r =$  periodic interest rate/100

All the future cash flows are discounted assuming an annual discount rate of 10%. Ultimately, runs are performed to record the net cash flow of the biorefinery for various cases, presented in the next section.

## 7.6 Results, Analysis and Discussions

Based on the described methodology in section 7.5, runs are performed to confirm the effective data transfer among the models. The initial step is to consider four cases based on the percentage utilization of the total feedstock available in the Jackson Purchase region. Appendix C.2 presents the details of the data used to initiate the iteration. The cases (1-4) are designated based on the fractional utilization (95%, 75%, 50% and 25%, respectively) of total biomass capacity in the region. Subsequently,



operating and capital costs are recorded as an outcome of the process optimization model (Aspen Plus®). Figure 7.5 illustrates the monthly costs at the biorefinery for the production of ethanol from corn stover via biochemical conversion route. These results are combined with the results from the supply chain optimization model (ILOG OPL®) to determine various potential biorefinery locations for respective cases.

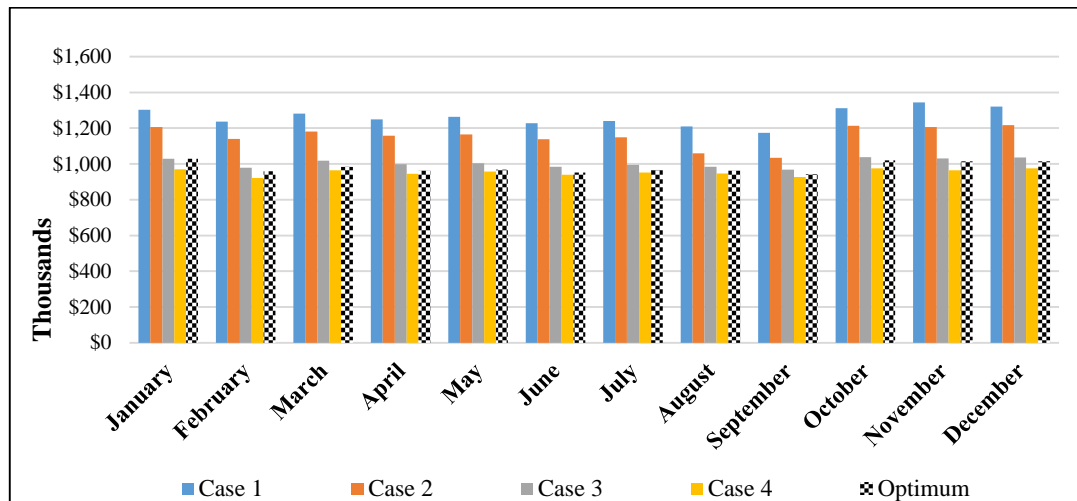

Figure 7.5 Monthly operating cost for various scenarios and optimum configuration

The costs and income generated from the overall supply chain is combined to determine the monthly cash flows. Figure 7.6 represents the contribution of expenses in a biorefinery, such as, operating, feed transportation, product transportation and feed purchase costs for the optimum scenario, which is discussed later. Combining these costs results in the estimation of total biorefinery operating costs. Eventually, the results obtained are transferred to the Arena® simulation (Discrete Event Simulation) model to validate the supply chain and perform further analysis.

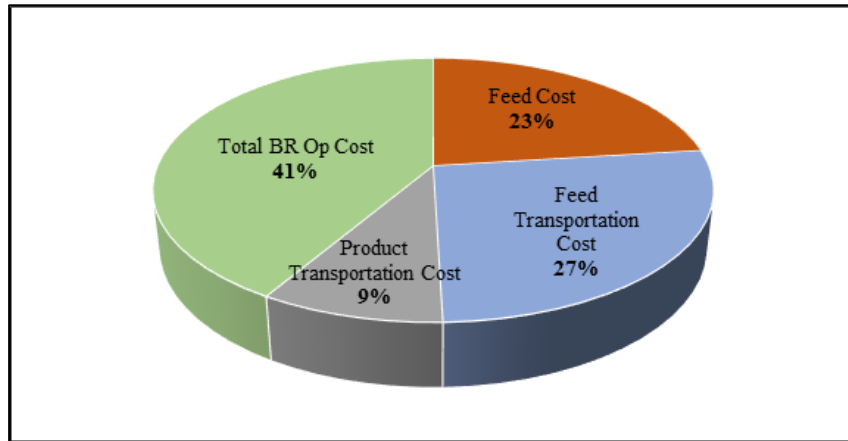

Figure 7.6 Share of various costs from the total operating cost for the optimum scenario (Result from the MILP)

The discrete event simulation model is run for a period of twenty years to calculate the variability and net cash flow of various cases described previously. For each capacity, the average cumulative NPV of the simulation replications is recorded. Figure 7.7 shows the change in NPV versus biorefinery capacity. This plot is subsequently used to obtain an analytical optimum capacity.

With an optimal capacity selected, iterative application of the chemical process optimization and supply chain optimization models provide revised set of inputs to be used in the Discrete Event Simulation model. It is observed that the simulation results are in agreement with the predicted optimum value. A sensitivity analysis is then performed by varying the values for the following parameters:

- cost of corn stover
- ethanol price
- electricity price
- diesel price
- capital cost
- operating cost

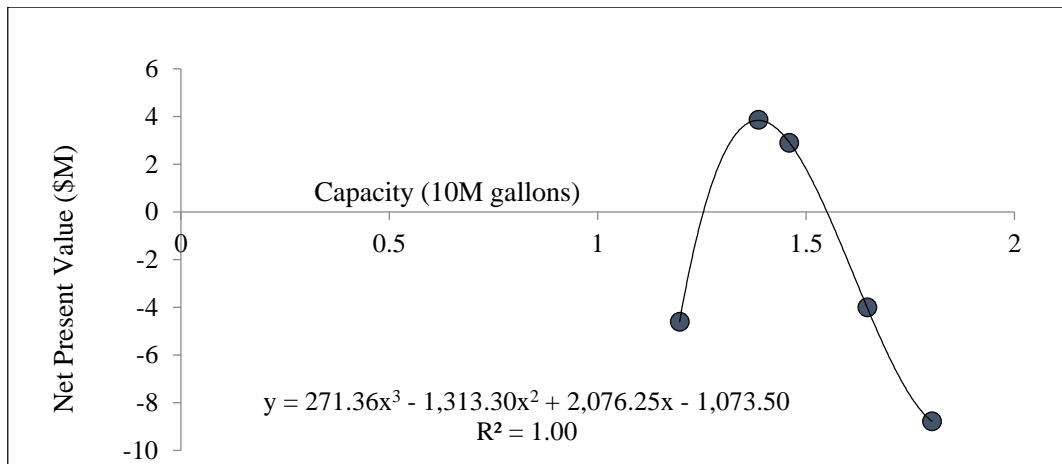

Figure 7.7 Plot showing the trend of the NPV and determined optimum capacity

As expected, the overall simulated NPV is most sensitive to the selling price of the main products of the process. In this case, the NPV is most sensitive to operating costs, which have a direct impact on the overall profitability of the system followed by the diesel price. Finally, the feedstock price and capital costs appear to have coinciding influence with changes in capital cost being slightly prominent. These sensitivities give important insights for stakeholder decision making and policy creation; identifying these variables, for instance, could help policy makers design favorable conditions for biorefining success in a region.

Results of sensitivity analysis of various parameters are shown in Figure 7.8. In Figure 7.8 (a) the NPV values are normalized to the base case simulation result and costs are normalized with base case values. This figure illustrates the influence of input costs on the simulated NPV for the supply chain system. Similarly, in Figure 7.8 (b), the influence of product prices are plotted versus the average NPV from 10 simulation iterations to illustrate the sensitivity of the simulation model outcome to product prices.

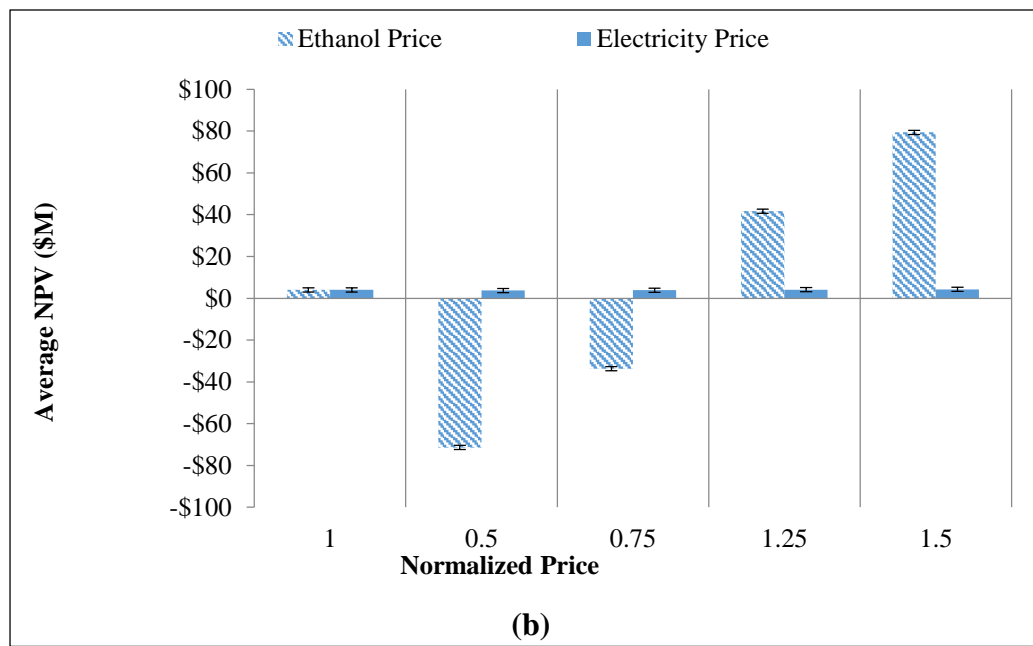
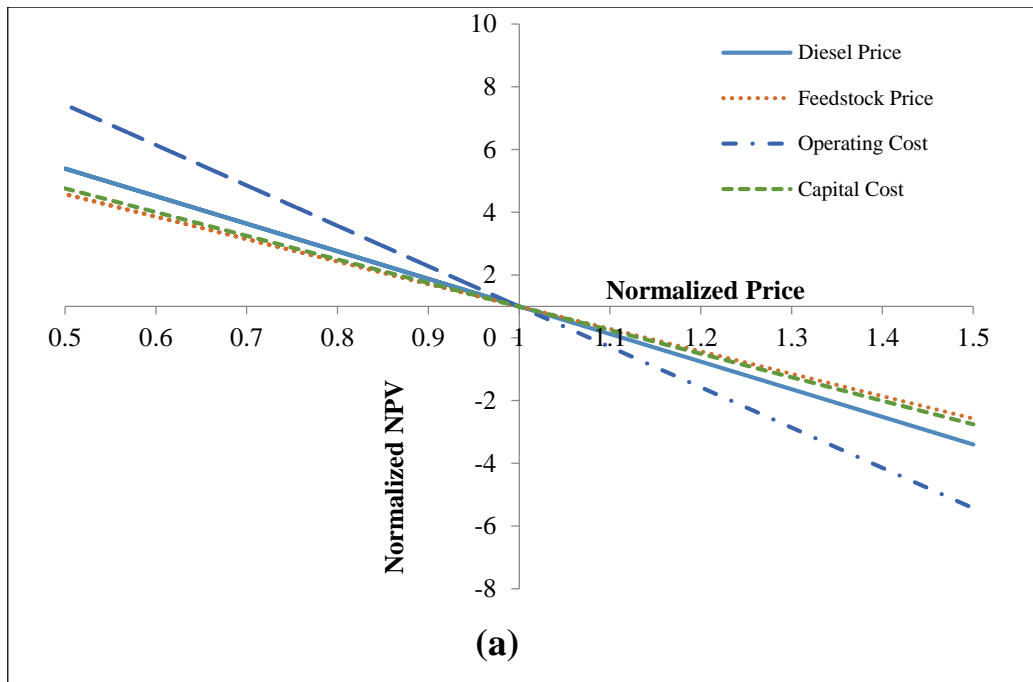

Figure 7.8 A graph showing sensitivity of various tested parameters. (a) Sensitivity of various costs with respect to normalized NPV. (b) Sensitivity of product prices versus average NPV

Further analysis is performed on the optimum scenario to demonstrate the level of detail that can be achieved by this framework. The relatively high resolution of results obtained are captured in Figure 7.9. This figure depicts the output from the

discrete event simulation model [89], that shows the variable costs for the 7<sup>th</sup> operating year. Hence, the innovative linking of the three models is further justified to capture the dynamic details of the process. One of the major observations is that, as the newly harvested biomass feedstocks are introduced (harvested in the month of August), the transportation diesel cost drops significantly. Whereas, there is a sharp rise in the operating cost of the biorefinery. This is due to the increased availability of biomass in the nearby locations which reduces the diesel cost incurred for transportation. Also, due to more availability, the biorefinery can accommodate production of biofuels in higher capacities, further resulting in an increase in operating costs. Similar observations can lead to higher insights for investors and policy makers to determine operating strategy and corresponding incentives to promote alternative fuel production in a given region.

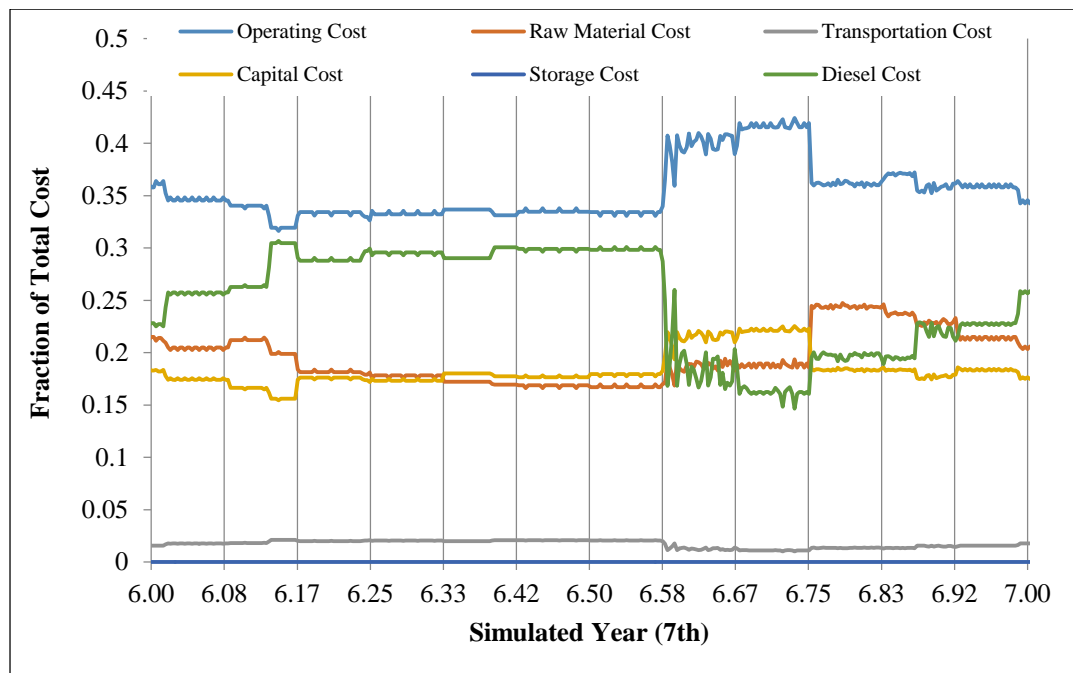

Figure 7.9 Fractional supply chain cost dynamics shown for the seventh year

Figure 7.10 shows the NPV as a function of time for the duration of a single simulation iteration (20 simulated years). The dynamics of the figure reflect the uncertainty of supply availability and product demand present in the discrete event

simulation model as well as the time value of money. It is estimated that for the biological process (corn stover to ethanol) and corresponding supply chain configuration, a net discounted profit of \$3.8 million will be obtained at the end of 20 years (assumed plant life), with a positive NPV obtained after 3 years of supply chain operation.

The results obtained can answer various questions concerning the long-term economic viability of the process of converting corn stover to ethanol in the Jackson Purchase region. As expected, the results of the case study show that the operating and transportation cost of a large capacity biorefinery increases, as the utility, raw material, feed and diesel consumption increases. Also, it is observed that the operating cost of the biorefinery is the highest contributor to NPV followed by feed transportation, raw material and product transportation costs. For case 1 through 4, the optimum biorefinery location is determined to be in Graves County. For the optimum case, the biorefinery site is in Hickman County with an annual capacity of 13.852 million gallons. Unlike the previous cases, the optimum biorefinery supply chain had larger product transportation costs and lower feed transportation cost. These results can be justified as transportation of energy dense ethanol is economically more favorable than low energy dense corn stover. Also, based on the sensitivity analysis it is observed that fluctuations in ethanol price may lead to significant change in the profitability of a biorefinery. Operating cost is the next most sensitive parameter whereas, raw material cost, capital cost and diesel price have similar impacts on the supply chain economics. The selling price of electricity is the least sensitive parameter in the case study. In summary, the results obtained in the case study not only provide a snapshot of the future scenario but, with inclusion of accurate data, can also predict the dynamics in the supply chain.

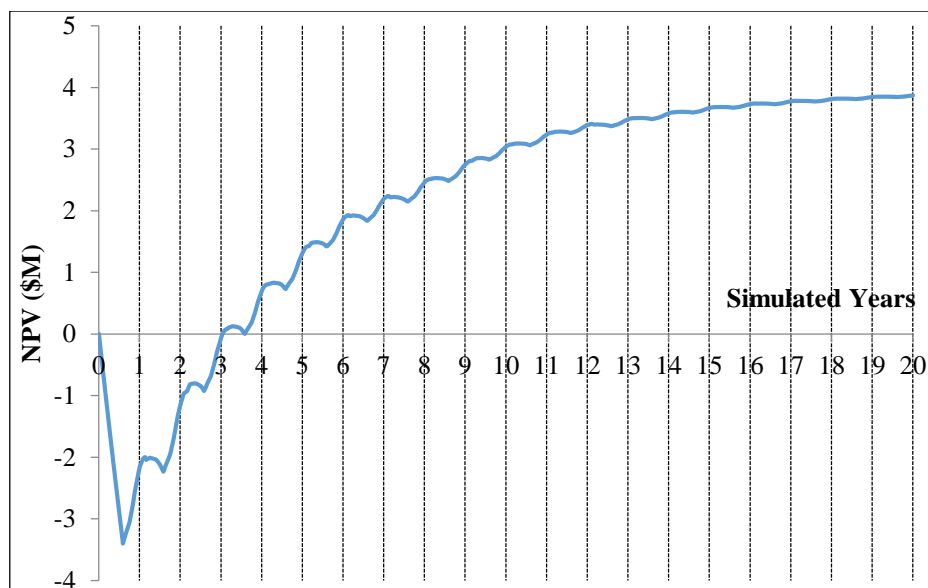

Figure 7.10 A plot showing dynamic increase in the NPV

## 7.7 Conclusions

The comprehensive tool developed as a result of this research is capable of analyzing various scenarios to provide insight into future economic implications of the emerging biorefining industry sector. The tool successfully demonstrates the integration of process simulation, supply chain optimization and discrete event simulation. The novel contribution is a stride taken in filling the gap between the existing intensive mathematical programming and process simulation models.

For the case study in the Jackson Purchase region, the model is appraised to determine key economic parameters pertaining to the biochemical conversion process from a multi-stakeholder perspective. Through the use of process simulation modeling, the tool can be used to verify the feasibility of lab scale research. The nature of outcomes from this framework will be of great value to investors as it will further fortify their decisions towards the use of any potential process in a given region.

One of the observations from the case study is that the price of ethanol is a sensitive parameter. This sensitivity can be potentially countered by providing

subsidies to the biofuel producers. Hence, this tool can be of great use to policy makers when deciding region specific subsidies. The case study shows that under the assumed circumstances, the corn stover to ethanol process can be profitable in the Jackson Purchase region. It must be emphasized that this research neither intends to create a conception or justify the use of one technique over the other, nor does it focus on its application to any specific region. The intention of this research is to illustrate a tool that can be quickly used to analyze economic feasibility of region specific biorefining.

Unlike fossil fuels, biofuels have an intimate link with agriculture. This tool can be used by growers to choose one or a mix of feedstock that can result in enhanced profit. The tool can also be used to quantify the improvements that can be achieved by switching crops or the alternative cultivation of dedicated energy crops. The following chapter will demonstrate the applicability of the model for hypothetical scenarios as well as its versatility in incorporating experimental details.



## **8. Diverse Applications of the Decision Support Tool**

The proof of concept studies have presented the applicability of the framework for thermochemical and biochemical conversion processes. However, other characteristics that validate the applicability of the framework, such as, its generalizability, capability for automation, inclusion of experimental data and potential for interfacing must be demonstrated. This chapter of the dissertation will present the above mentioned attributes of the proposed novel framework.

The contents of this chapter are adapted or taken directly from the previously published work in *Computer Aided Chemical Engineering*, Proceedings of the 8th International Conference on Foundations of Computer-Aided Process Design, Volume 34, S. Sukumara and J. Seay, 2014, “A novel model for evaluating the viability of strategies for biorefining processes from various stakeholder perspectives: Case study on marginal land utilization”, pages 627-632, with kind permission of Elsevier[180].

### **8.1 Studies Demonstrating Applications and Interfacing of the Multidisciplinary Framework**

A case study is demonstrated on a hypothetical scenario that tests the introduction of a promising feedstock into an existing supply chain. This section will demonstrate the manner in which the informative framework can be utilized to examine loss mitigation strategies by introducing a new feedstock. However, the addition of process constraints and experimental details into the developed model is a challenging task. Nevertheless, the inclusion of these specifics, link the developed models to fundamental sciences, making this contribution novel. This chapter demonstrates the approach by which these details can be entered into the existing framework. Subsequently, interfacing capabilities of the framework are tested and potential venues

for the automation are explored. The following sections will expand on the studies performed to validate applications of the framework.

## **8.2 Marginal Land Utilization**

Extensive knowledge about the existing processes and feedstocks of biorefining has led to a comprehensive assessment of previously performed case studies. However, the main objective of the developed framework is to act as an informative tool for both current and future conversion scenarios. This section demonstrates the manner in which a hypothetical supply chain configuration can be analyzed by the framework. Hence, a new production strategy is analyzed by testing an assumptive scenario. This scheme will capture the ability of the model to test potential profit enhancing strategies. Motivated by the previous research, a proof of concept study is performed in the Jackson Purchase region to assess the impacts of inclusion of a dedicated energy crop into the existing supply chain by utilizing the available marginal land in the region. The appraisal of this study will prove the application of the framework to prospective configurations.

### **8.2.1 Introduction**

Generating ample quantities of biofuels, to satisfy the rising demand, requires increased cultivation of bio-based resources. Subsequently, as we plan for the development of sustainable biorefineries, a parallel scheme for land utilization must be developed. Dale *et al.* (2010) emphasized elaborating the studies to evaluate the potential marginal land available along with abandoned croplands and pasture lands [181]. Consequently, in the future, various schemes of land utilization will be explored for its probable use to grow feedstocks for biorefineries. Hence, a framework is required that can support the emerging research to assess the impact of land utilization for growing dedicated energy crops. This case study extends the state of art framework [21]

to demonstrate another potential scenario for biofuel production in the same region. Additionally, this case study shows the method by which emerging future scenarios, such as, utilization of marginal land to cultivate dedicated energy crops, can be tested for viability. For this case study, the process of biomass gasification is appraised for its feasibility in the Jackson Purchase region of Western Kentucky, USA.

### **8.2.2 Background**

In recent years, several techno-economic models have been presented that capture various details of biomass transportation and conversion processes. However, more effort is focused on combining these two critical aspects of biorefining, in order to calculate realistic estimates. The supply chain and process optimization models can be combined to result in an innovative multi-disciplinary framework [21] that can be used by investors and policy makers to evaluate economic, environmental and societal parameters. However, all the previously obtained results, corresponding to various capacities of biorefinery production, showed an undesirable capital cost recovery in spite of a net yearly operating profit. These results motivated further assessment and exploration of possibilities to improve the economic performance of a potential biorefinery. Among the several available options, utilization of locally available marginal land appears to be a promising alternative.

It may not be self-evident but a large area of marginal land is available in different parts of the world [182]. As the land usage for industrial and commercial practices is increasing progressively, utilization of available marginal land has become critical. Previous literature [182], has provided a review of the historical development of marginal land utilization and its future applications. It further stated that, the management of marginal land is crucial as it acts as a perfect venue to cultivate second generation lignocellulosic biomass. Gelfand *et al.* (2013) [183] demonstrated six

cultivation systems in the USA (Midwest) for the utilization of marginal land. While the available marginal land is in abundance, the contribution stated that practically only 10% of the land can be utilized. However, Butterbach and Kiese (2013) [184] raised many concerns over the study [183]. The major ones being:

- Utilization of the available marginal land without having adverse effects on the local bio-diversity.
- Emphasized the need for a more comprehensive framework to estimate the long-term impact on the climate.
- Stressed performing analysis to contrast the future utilization of marginal land for cellulosic and food crops.

While both the works have explored as well as raised concerns over the potential utilization of marginal land, it must be realized that we still need a comprehensive tool that provides details to further substantiate the above claims. The work demonstrated in this research provides a crucial contribution by quantifying the economic impacts of the transformed supply chain. Also, for developing economies, with increasing population, the utilization of marginal land becomes a key factor to satisfy both the need for growing food and generating bioenergy [185, 186].

Previous research [187] identified the utilization of marginal land as a key trait that can be explored for sustainable biorefining. However, the properties of marginal land varies significantly from one region to another [181]. Hence, it is necessary to study the feasibility of growing energy crops in desired regions. This report shows that the Jackson Purchase region has the potential to grow crops, such as, switchgrass, miscanthus, pine, sweetgum, hybrid poplar and sorghum. In another significant contribution [188], abandoned agricultural land in the state of Kentucky was examined

and estimated for potential availability. The subsequent sections demonstrate how these two aspects can be combined together so that it can be embodied into the existing supply chain.

The foundation presented here is a unique combination of process and supply chain modeling that can generate and optimize data simultaneously. In summary, the objective of this case study is to generate a distribution for the availability of dedicated energy crops and examine its economic viability as a potential biorefining feedstock, using the multidisciplinary decision support tool. While extensive analysis can be performed, this research will show the incorporation of external data to capture the results for a modified supply chain. This adaptable framework has been altered to accommodate another possible scenario as shown in the following section. It must be understood that the framework has the ability to accommodate varying (increasing or decreasing) feedstock availability as illustrated in previous chapters (Chapter 6 and 7). Supplementing to this, the current proof of concept demonstrates another critical dimension of the developed tool by estimating potential optimum utilization of marginal land to cultivate dedicated energy crops in the region.

### **8.2.3 Methodology**

The core methodology of this framework is inspired by previous research [21] as presented in Chapter 4. The presented methodology demonstrates the adaptability of the framework to incorporate multiple possibilities. However, the challenge is to introduce a new feedstock to test for its long-term viability. In order to assess the feedstock, a corresponding distribution is created based on realistic assumptions. The first step is to estimate the available marginal land in the region of interest, followed by coupling of the data with crop yield. Secondly, due to the lack of historical data, a range for potential production of dedicated energy crops is calculated. Subsequently, based

on the derived distribution, the Aspen Plus® process simulation model for biomass gasification is run, followed by the ILOG OPL® supply chain optimization model [21]. Finally, an optimum supply chain along with variable operating costs and total capital investment are determined. Figure 8.1 shows an algorithm for the suggested methodology.

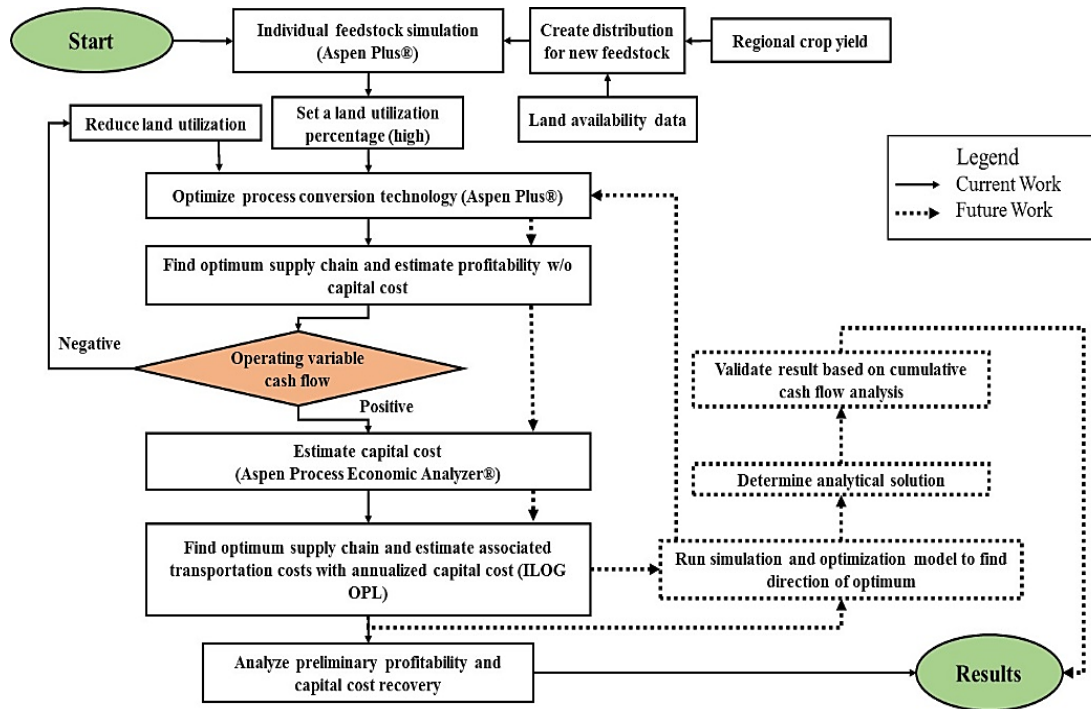

Figure 8.1 Methodology used for the case study on the marginal land utilization

The algorithm developed is for preliminary analysis and may subject to potential modifications based on the regional variability of the product or feedstock. Currently, with this framework, several operating configurations can be tested to determine the economic feasibility. More importantly, the present research is evolving to make the results accessible to major environmental and societal indicators.

In order to demonstrate the applicability of dedicated energy crops in a given region, a case study is designed. The proof of concept model is tested in the Jackson

Purchase region. The following are some of the major assumptions that go into the individual stages of the model.

- Marginal land available in the region is utilized by existing farmers, hence the collection point of switchgrass is assumed to be same as corn stover. Further, the total availability of biomass is determined for each county and assumed to be distributed in the same proportion as corn stover.
- Storage costs at the feedstock collection site are not accounted in the present study.
- Demand at the product storage locations/depot are assumed to be high to accommodate any production rate, therefore, allowing the model to assess several configurations and capacities.
- Degradation during the transportation is assumed to be the same as for corn stover

Based on these assumptions, the existing framework is modified to run various scenarios in succession and provide the desired output.

### **8.2.3.1 Feedstock Assessment and Distribution**

The Jackson Purchase region is located in one of the most favorable geographic regions in the USA for the production of switchgrass. In recent years, many researchers have performed studies on switchgrass and other perennial grasses, warranting its applicability for this case study. Figure 8.2 shows marginal agricultural land available in the region and corresponding county wise switchgrass yields.

Combining these two data sets, a distribution is developed to project the regional availability of switchgrass. A crop yield of 10.52 t/ha is used for this distribution. In order to capture various scenarios leading to an optimum operating biorefinery configuration, iterations are performed on 15 % and 10 % marginal land utilization. Further, in order to encompass realistic problems, such as, degradation, two other

distributions are generated assuming 10 % monthly storage loss for respective land utilization. Also, switchgrass has a broad harvest window [189], hence it is assumed that the harvest is performed in the months of November, December and January.

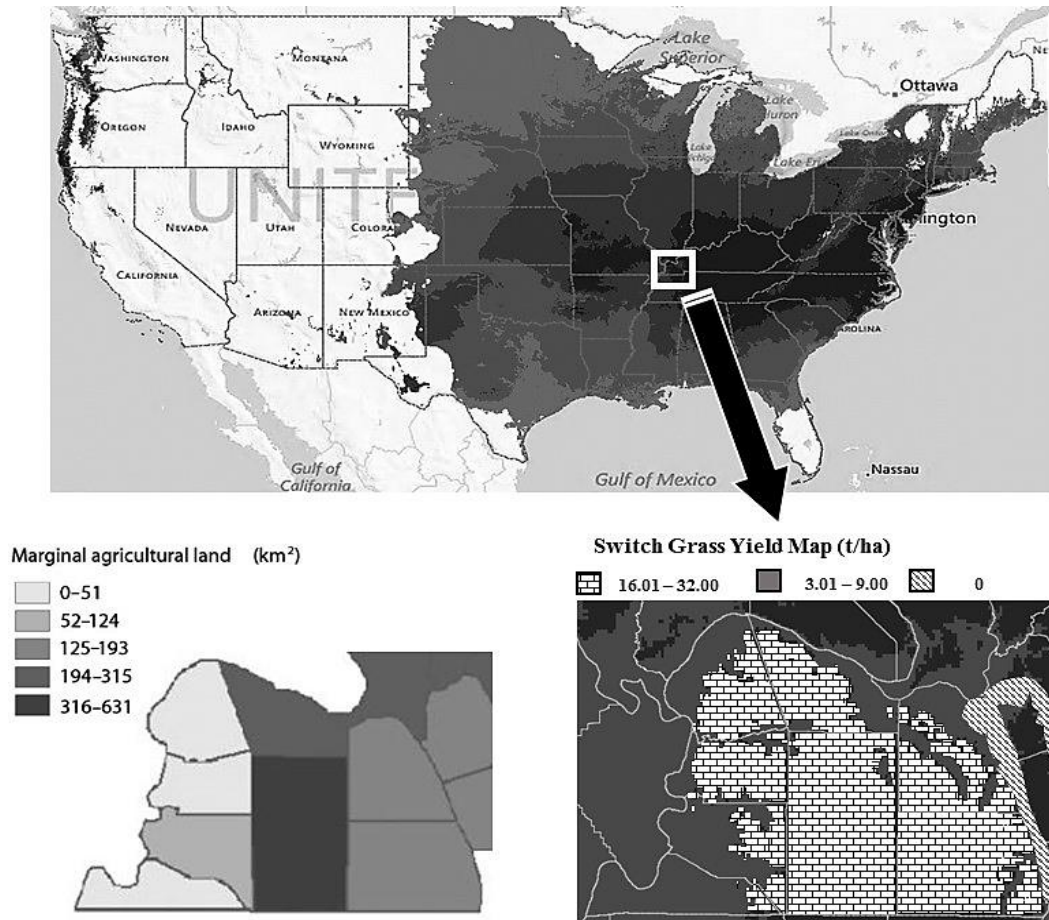

Figure 8.2 Map showing potential yield (Top) of switchgrass [175]. Zoomed version (Bottom right) of marked area on the switchgrass yield map. Marginal agricultural land (Bottom left) available in the Jackson Purchase region [188]

### 8.2.3.2 Overall Simulation and Optimization

Finally, the modified model is run, as described in section 8.2.3, for multiple scenarios (elaborated in the subsequent section). A feed flexible biomass gasification process is used to incorporate the switchgrass distribution generated along with previously determined optima for chicken litter, corn stover and forest residue for a



medium scale biorefinery [21]. The biomass gasification process is followed by synthesis gas cleaning and WGS reaction. Finally, the synthesis gas is split into two streams, for power generation and liquid hydrocarbon production by FTS [21]. This conversion process results in the production of energy and hydrocarbons (C<sub>1</sub>-C<sub>30</sub>) which are assigned a cost based on the marketable fuel cut. Throughout the iterations the process optimization model remains the same as used in the previous case study. It is possible that the incorporation of another feedstock may require additional processing steps. While capturing the details pertaining to the introduction of another feedstock is out of the scope of this research, the framework developed The results obtained are passed to the ILOG OPL® model [22] which optimizes the supply chain to determine the most profitable biorefinery location. The objective function for both the process and supply chain simulation is set to maximize the operating profit.

#### **8.2.4 Results and Discussions**

For the purpose of analysis, four scenarios are assumed and tested for their economic performance and environmental emissions. These are:

- Scenario 1: 10 % land utilization with no degradation
- Scenario 2: 10 % land utilization with 10 % monthly degradation
- Scenario 3: 15 % land utilization with no degradation
- Scenario 4: 15 % land utilization with 10 % monthly degradation

All four scenarios are run in succession as shown in Figure 8.1. The results from the process simulation and supply chain optimization models are combined to determine the critical cost contributors. Several optimum incoming and outgoing costs, such as, operating utility, feed transportation, product transportation (to storage depot), capital investment and product income are determined, based upon which the net cash

flow analysis is performed. Subsequently, the optimum supply chain network, emissions and jobs created by the biorefining process are determined for their respective configurations. Additionally, the extensive results obtained can be further interfaced with the existing societal and environmental impact indicators to give accurate estimates regarding sustainability. Figure 8.3 (a) depicts a cumulative cash flow analysis which is performed on an operating biorefinery for 10 years. Also, the monthly trend for CO<sub>2</sub> emissions is calculated based on Aspen Plus® process simulation results for all the four configurations, as illustrated in Figure 8.3 (b).

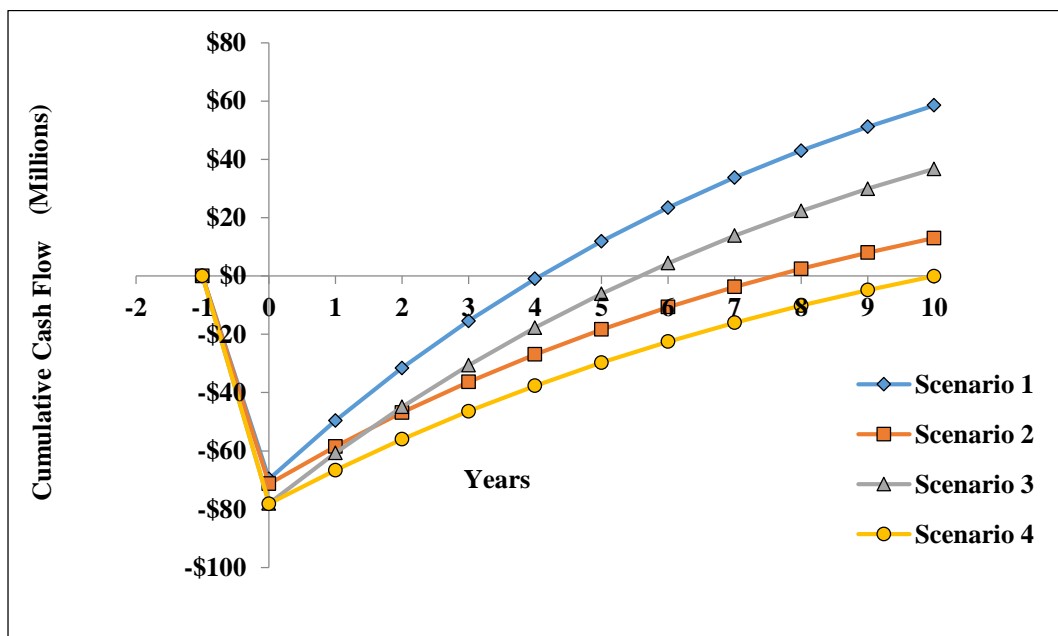

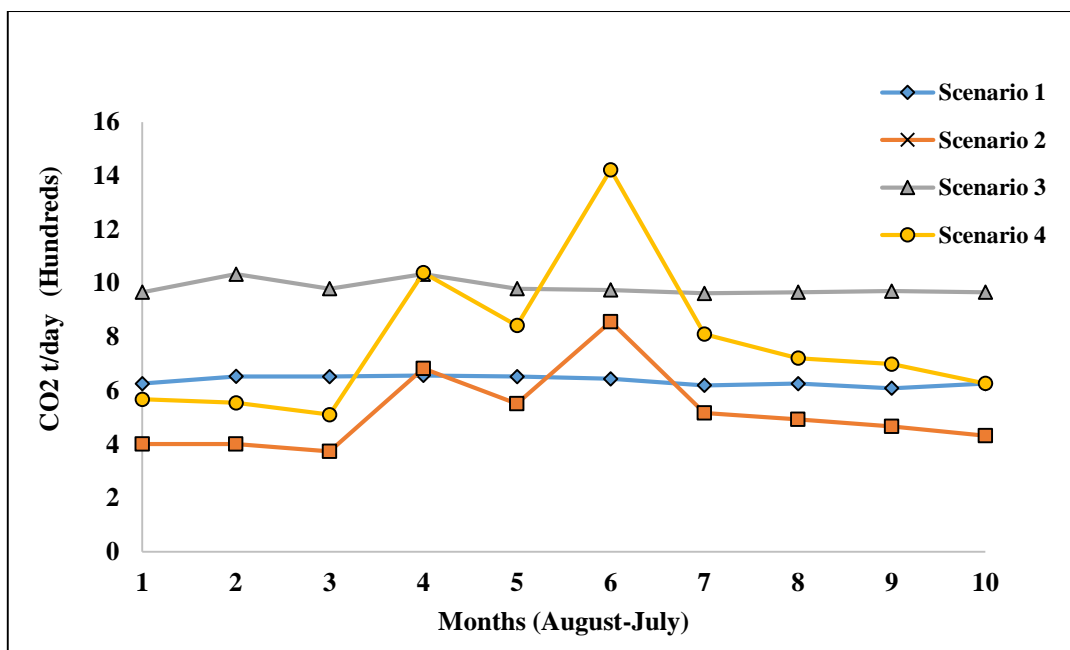

Figure 8.3 (a) Cumulative cash flow analysis. (b) Varying monthly emissions

The results shown in this study are a few amongst the many obtained as an output from this model. The preliminary analysis shows a better payback period in comparison with the previous results for a medium capacity biorefinery. Hence, the above results should be further investigated for an optimum mode of operation involving switchgrass as a feedstock. Also, it is observed that the two scenarios with degradation did not perform well, as those are burdened with high capital cost and low rate of recovery. A storage facility which can minimize degradation requires capital investment, the addition of which may push the period for capital recovery further. The addition of the previous costs changes the cumulative cash flow trend of the first and third scenarios as these do not assume any loss due to storage.

Another observation is the peaks shown in the CO<sub>2</sub> emissions plot. These are explained as comparatively more switchgrass is set to be consumed in the month of November, December and January. This consumption is primarily dependent on the selected month for the harvest of switchgrass. While the literature shows various

harvest period for the crop [190, 191], the study shows the importance of exploring the harvest options such that the feed supply to the biorefinery is as steady as possible. However, it should be recognized that alteration in the harvest strategy affects the composition and yield of biomass [192, 193], possibly effecting the profitability and capital recovery period of the biorefinery.

The direction of future work should be aimed towards determining the optimum configuration of a biorefinery based on gasification with capital investment in storage. A preliminary optimum based on the net present value is determined at 11.5 % land utilization, by running iterations between the process optimization and supply chain optimization models. Appendix D.1 depicts the graph that is used to determine the optimum land utilization. In the future, to capture the impact of the inherent variations in the supply chain, a dynamic analysis must be performed including the discrete event simulation model.

### **8.2.5 Conclusions and Future Research Directions**

The multidisciplinary decision support tool demonstrated via this research can be modified based on regional requirements, quantifying the viability of any bio-based feedstock. In the future, several other potential biomass resources can be tested for their viability. Nevertheless, significant future work needs to be carried out to obtain more realistic results. Major ones being:

- Incorporation of multiple biorefining conversion techniques
- Linking the model with environmental and societal impact assessment tools
- Automation of the described framework using Visual Basic® for Applications
- Include several grid search methods to determine analytical solutions

In conclusion, with the completion of the above mentioned work, the potential profitability of an integrated biorefinery can be assessed using this framework, thus providing insight regarding various biorefining scenarios. This strategy support tool can be used by investors and policy makers to analyze and compare possibilities, assisting in the estimation of monetary investments and deciding local policies, respectively. With proper interfacing and improved ease of use, this tool can provide justification to encourage farmers to confidently proceed with the cultivation of promising dedicated energy crops. The following sections demonstrates the way by which automation and interfacing is explored for the existing multidisciplinary decision support tool.

### **8.3 Interfacing the Model with User-Specified Details**

One of the major attributes of the framework is its ability to include fundamental details and adaptability to varying inputs. This robustness can be attained by utilizing various built-in features in the process simulation tool. The objective for choosing a tool, like, Aspen Plus® is to exploit versatile applications to incorporate fundamental details. This feature enables experimentalists to test their lab scale outcomes to foresee the economic viability of the research. Also, the use of built-in tools facilitates the effective inclusion and automation of the process for a given set of user specified inputs. The following sections elaborates on each of the above mentioned characteristics.

Most of the emerging biorefining processes employ novel conversion techniques based on the type of feed or optimum process parameters. Therefore, such details must be included in the process simulation model to capture the reality of conversion techniques. The existing work limits the ability to incorporate these details by the inclusion of specific reaction kinetics.

In a process simulation, there are multiple ways to include specifics, such as, reactions, design specifications and varying parameters. This section focuses on the working of techniques applied by the research so far, the prominent one being the ability to incorporate user-supplied functions that can compute and control process parameters, such as, flow rates, yields, stoichiometric coefficients, reaction parameters and reactor design variables. The primary function being to control the flow rates of reactants to the gasifier and WGS reactor. Similarly, for biochemical process, the user-generated functions are imposed on water,  $\text{Ca}(\text{OH})_2$ ,  $\text{H}_2\text{SO}_4$ , enzymes, steam and air flow rates. While there are several additional uses of this approach, the framework currently limits the utilization by incorporating the previously mentioned applications. In the future, depending on the user requirements many more details can be added to the existing processes which will complement the working of the decision support tool.

Biorefining is a combination of various batch and continuous processes. Pertaining to the conversion, varying forms of kinetics may not be adaptable with the existing input format of the simulation. Hence, in order to incorporate these aspects, user specified options have been explored. Depending on the requirements, the existing stoichiometric reactors can be linked to internal or external FORTRAN inputs. Internal FORTRAN kinetic and stoichiometric inputs can be provided by calling the process parameters and assigning the inputs using a user-defined function within the simulation environment. Whereas, an external dynamic linking can be provided by coupling an externally compiled FORTRAN subroutine (.dlopt file) to the corresponding unit in the main simulation. The external dynamic linking provides improved opportunities for customizations but requires rigorous coding using FORTRAN. These customization options are of great importance to embody the experimental outcomes of the developed steady state process simulations. Depending on the need, these FORTRAN codes can

be compiled by the built-in Aspen Plus® units, such as, RYield, RStoic, RBatch or RCSTR. Sample code (in FORTRAN) used to replicate the process of cellulose hydrolysis based on kinetics from a previous literature [194] is presented in Appendix D.2. Such codes can be modified and linked to an existing simulation model to incorporate the equations based on the experimental findings.

Currently, the simulations use user-defined functions (mentioned previously) to enforce the specified constraints and process parameters. However, based on the necessity other existing built-in Aspen Plus® options, such as, “Design Specs” and “Sensitivity”, can be used to limit and analyze the performance of the biorefining processes.

#### **8.4 Potential to Link the Models Using Visual Basic® Applications**

Presently, the process and supply chain models developed provide several critical details. It is important to channel all the needed results from one model to another. While performing iterations, such a practice reduces the run time significantly. To demonstrate this aspect of interfacing, runs are performed between Aspen Plus® and ILOG OPL® for both thermochemical and biochemical conversion processes.

To explore the interfacing capabilities, runs are performed iteratively using the Visual Basic® interface. The runs utilize a dedicated Visual Basic® for Application user interface between Aspen Plus® and ILOG OPL®. While Aspen Plus® can be controlled using the Microsoft Excel® interface, ILOG OPL® also has the ability to exchange results to the same. Based on these interfacing restraints, several runs on the developed process simulations and corresponding optimization models are performed. Subsequently, the Microsoft Excel® worksheet is modified such that the results from the simulation can be interfaced with the supply chain optimization model with minimal

operations. This is achieved by creating multiple Macros tabs (built-in Visual Basic® application) to facilitate the data transfer between the worksheets. Finally, iterations for both thermochemical and biochemical process are performed for varying capacities. It is observed that the process takes approximately 120 s to complete the data exchange for an iteration on a computer with 4GB RAM and Intel® Dual-Core processor. Figure 8.4 explains the manner in which this interfacing is achieved.

Based on the observations, an alternative method to perform the runs is determined by utilizing the user-specified (sensitivity) functions. Employing this application of the simulation reduces the total run time significantly and enables analyzing several scenarios in one run. Appendix D.3 depicts the methodology of data transfer between the Aspen Plus® and ILOG OPL®. The objective of performing runs is to determine the existing challenges in automation of the framework. Once the optimum process flow diagram is determined, the range of input based on which the runs are performed is selected. Iterations are performed until the optimum configuration is validated. The iterations begin by specifying the inputs which can be changed by allowing the access to those variables without opening the Aspen Plus® user interface. Subsequently, the outputs, such as, optimum feed, optimum product slate, process utility costs, raw materials costs and capital investment is specified that needs to be conveyed to the supply chain models. Then, these are transferred to another worksheet inside the Microsoft Excel® file using the macros (Visual Basic®).



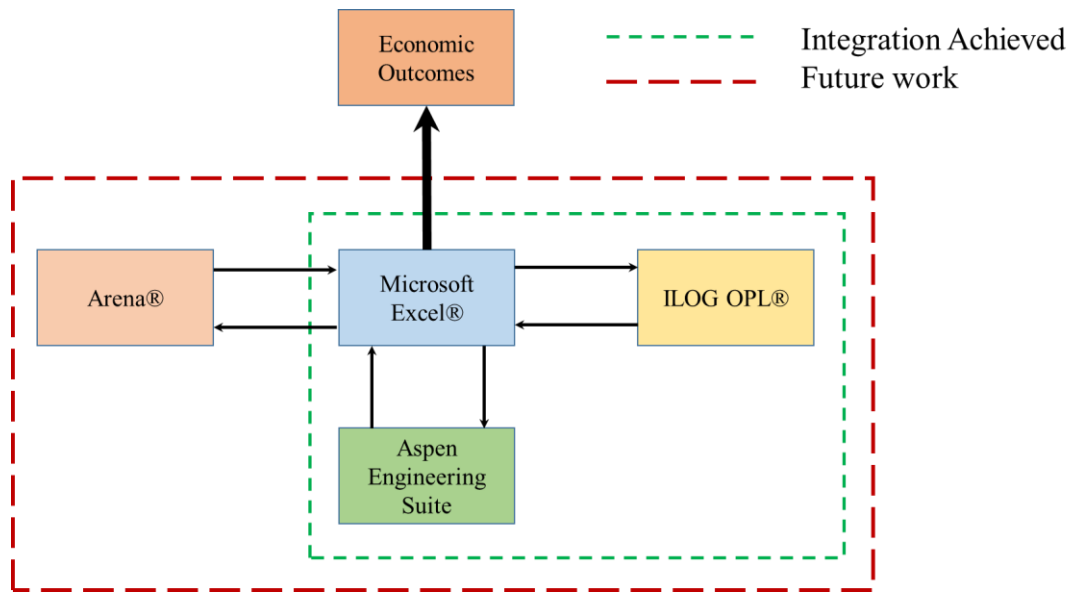

Figure 8.4 Proposed interfacing scheme to improve usability of the framework

While the supply chain simulation cannot be run directly from the Microsoft Excel® interface, it has the capability of importing and exporting data. This feature is explored as the output data from the Aspen Plus® is fed to the ILOG OPL® as an input. After running the optimization program, the results are transferred to another Microsoft Excel® worksheet. Here, the cumulative data of the process and supply chain optimization models are evaluated and the combined results are transferred to the discrete event simulation model. The runs performed in the discrete event simulation model marks the end of one iteration. Similar processes for varying inputs are performed until an optimum is validated. The validation is performed based on various economic parameters, such as, Net Present Value (NPV), Payback Period and operating profit. The runs performed in this contribution maximizes the NPV of the biorefinery. This research not only aims to evaluate the economic outcomes but also intends to improve the ease of use of the framework. This aspect of the model is critical as improved and simpler interfacing leads to increased usability among the stakeholders.

## 8.5 Conclusions

The developed tool can incorporate various details that improves the usability, adaptability and generalizability of the model. The framework can be used by growers and policy makers to test the impacts of a new feedstock to an existing scenario. Also, the model provides insight to growers in managing the utilization of available land to grow bio-based feedstock for biorefining. Ultimately, several more case studies must be designed to test the viability of potential operating configurations.

The framework not only encompasses the broad objective of calculating the economic parameters of biorefining processes, but also provides improved access to the model, such that it can be used by experimentalists to test the viability of their research outcomes. The use of user-supplied functions and compiled FORTRAN commands demonstrate two of the many available ways to enter the technical parameters. However, this aspect must be explored further to enhance the accuracy of results.

Finally, with adequate interfacing, the framework can be used by stakeholders from various professional background. While all the previously mentioned contributions have added to the improvisation of the existing framework, in the future, more work needs to be done in order to enhance each of the individual aspect. The final chapter of this dissertation will suggest some key future directions that must be adopted to improve the framework.

## **9. Conclusions and Future Work**

This chapter will summarize the proposed integration and contributions achieved by the research. Major achievements of the novel decision support tool are highlighted and avenues for future contributions are stated. Eventually, based on the learnings from this work, future research directions are presented to enhance the performance of the developed framework.

### **9.1 Summary of Achievements**

The goal of this research is to develop a framework that can evaluate the economic viability of various biorefining processes from multiple stakeholder perspectives. Working towards this objective, a decision support tool has been designed that can link the major aspects of the conversion technique and transportation logistics. Doing this requires multidisciplinary linking of process simulation models with the supply chain optimization and discrete event simulation models. A unique iterative process is proposed that links the stand-alone models developed in Aspen Plus®, ILOG OPL® and Arena®. While designing each of the previously described models is critical, the contribution has also focused on the development of conversion process simulation and integration aspects of these models to create a multidisciplinary decision support tool. This unique linking is a novel achievement in the field of PSE. To demonstrate the promising operations of the framework, proof of concept studies have been performed on the thermochemical and biochemical processes to produce power, transportation fuel and marketable chemicals. The iterative framework has been run several times until the optimal production capacity is determined and validated. One of the major characteristics of the developed model is its generalizability. In order to validate this aspect, a case study has been performed on a hypothetical scenario. This study not only proved the versatile applicability of the tool, by demonstrating a potential

scenario, that can provide promising alternatives to improve profit but also identified venues for the future, by presenting the economic impact of potential utilization of marginal land in the Jackson Purchase region. Subsequently, various options are shown that can be used by experimentalists and engineers to incorporate their research outcomes. Finally, an effort to reduce the run time and improve the usability of the framework is demonstrated by the utilization of a dedicated Visual Basic® applications interface. The following section will present the conclusions that can be drawn based on the accomplishments of this dissertation.

## **9.2 Conclusions**

The research presented in this dissertation has made several contributions to the scientific community. One of the major contributions of the collaborative work is to create an innovative framework that can accommodate process and supply chain optimization models. This multidisciplinary tailoring resulted in a unique decision support tool that can run iteratively to determine the optimum configuration based on economic parameters. The case studies presented the working of a unified framework for thermochemical process of gasification, followed by WGS and FTS reactions, to produce liquid hydrocarbons and power. While the process has potential for improvements, the optimum configuration did not result in a desirable payback period. The economic parameters presented by the tool is thorough in nature and can be utilized by investors to avoid any non-profitable scenario in the long-term.

Subsequently, using the novel decision support tool, another study is performed to test the viability of the biochemical conversion process to produce ethanol from corn stover. The process showed improved economic outcomes compared to the thermochemical conversion technique. However, based on the literature studies it must be acknowledged that the biological conversion process is subject to higher

uncertainties and hence, is highly sensitive to feed composition and the presence of impurities. The framework shows the capability to incorporate both the processes. But more importantly, it demonstrates the manner in which the developed tool can be used to compare various biorefining processes. The contribution does not intend to justify any single processing technique but instead the virtue of this research lies in the ability to capture economic impacts of the existing and emerging processes.

The biomass gasification processes is further appraised to determine a strategy that can enhance the performance of the existing scenario to mitigate economic loss. The results concluded that the potential utilization of marginal land to cultivate dedicated energy crops is a promising option. While the results are encouraging for growers, policy makers and investors, this study shows the capability of the framework to incorporate suppositional schemes for assessment.

Multiple avenues to incorporate experimental details are explored in the research which enhances the usability of the model by researchers. Ultimately, in order to improve the applicability of the decision support tool, usability is augmented by utilizing a dedicated Visual Basic® applications interface. However, this aspect needs to be explored further to automate the framework such that it can be used by the stakeholders from various professional background.

### **9.3 Future Work**

The multidisciplinary framework provides insight for stakeholders by estimating the potential impacts of the production of biofuels in a given region. While the current nature of the work is comprehensive, based on the attainments, multiple directions for future upgrading of the model are proposed. The following points illustrates the major future research venues determined so far.

- Pre-screening tool: The process of developing and running scenarios in the framework is time consuming. Hence, a screening model should be developed that can eliminate infeasible configurations, saving the time consumed for running the non-viable scenarios.
- Multiple facility location schemes: The current scheme for biorefining is based on a centralized facility location. However, depending on the varying properties, such as, moisture content, significant savings may be obtained by a two stage biorefining process. In the future, the framework should be modified to incorporate centralized, distributed and two stage biorefining schemes.
- Environmental impact assessment: Emissions during the conversion process can be estimated by the current model. However, in order to calculate the impact of emissions throughout the supply chain, the model must be coupled with a LCA tool or the optimization must be performed incorporating the objectives to minimize emissions.
- Societal impact assessment: Similar to the previous strategy, the decision making constrained objective function should also incorporate social impacts to accurately measure all aspects of sustainability.
- Addition of other conversion processes: The existing model consists of two processes (thermochemical and biochemical). In the future, more conversion processes, such as, conversion of agricultural residue and dedicated energy crops to bio-butanol should be included.
- Addition of stochastic data: Currently, the model begins its iteration with a set of deterministic demand and feedstock data. In order to capture realistic variabilities, the stochastic nature of the input must be incorporated.

- **Modified interfacing:** Currently, the developed model has limited automation capability and often requires manual data transfer. A platform must be discovered that can accommodate all the tools involved in the development of the framework.

The inclusion of previously mentioned future work will significantly enhance the capability of the unique framework. This will result in the development of a complete decision support tool that can guide various stakeholders in determining the impact of sustainable biorefining.

In summary, an informative decision support tool is developed as a contribution of this novel research. The framework can be used as a guide by investors in deciding the optimum operating capacity and sensitivity parameters involved in the supply chain. Hence, the investors can make informed decisions in planning the logistics and process configurations of future biorefineries. The framework can be used by policy makers to decide subsidies and incentives which encourages investment in this sector. Also, the impact of future uncertainties can be evaluated that will assist in the long-term planning. Finally, growers and investors can use this tool to evaluate tactics to improve the utilization of existing land resources and potential feedstock that can be mutually beneficial in the long-term. While the social and environmental impacts can be partially determined by the model, the main focus of this contribution has been towards establishing economic viability, which is an essential factor in determining the sustainability of any biorefining process.

## Appendix A

### A.1 Reactions and corresponding parameters in the chemical pre-treatment

section [54]

Reactions	Parameters	Value
<b>Pretreatment section</b>		
CELLULOS + H <sub>2</sub> O --> GLUCOLIG	Temperature	190
CELLULOS + H <sub>2</sub> O --> CELLOB	(°C)	
CELLULOS + H <sub>2</sub> O --> GLUCOSE	Pressure (atm)	1
XYLAN + H <sub>2</sub> O --> XYLOSE		
XYLAN + H <sub>2</sub> O --> XYLOLIG		
XYLAN --> FURFURAL + 2 H <sub>2</sub> O		
ACETATE --> AACID		
LIGNIN --> LGNSOL		
MANNAN + H <sub>2</sub> O --> MANOLIG		
MANNAN + H <sub>2</sub> O --> MANNOSE		
MANNAN --> HMF + 2 H <sub>2</sub> O		
GALACTAN + H <sub>2</sub> O --> GALAOLIG		
GALACTAN + H <sub>2</sub> O --> GALACTOS		
GALACTAN --> HMF + 2 H <sub>2</sub> O		
ARABINAN + H <sub>2</sub> O --> ARABOLIG		
ARABINAN + H <sub>2</sub> O --> ARABINOS		
ARABINAN --> FURFURAL + 2 H <sub>2</sub> O		
FURFURAL + 2 H <sub>2</sub> O --> TAR		
5 HMF + 9 H <sub>2</sub> O --> 6 TAR		



<b>Neutralization</b>		
CA(OH) <sub>2</sub> + H <sub>2</sub> SO <sub>4</sub> --> GYPSUM	Temperature (°C)	0
	Pressure (atm)	1

### A.2 Reactions involve in saccharification and fermentation section [54]

<b>Reactions</b>	<b>Parameters</b>	<b>Value</b>
<b>Saccharification</b>		
CELLULOS + H <sub>2</sub> O --> GLUCOLIG	Temperature	65
CELLULOS + H <sub>2</sub> O --> CELLOB	(°C)	
CELLULOS + H <sub>2</sub> O --> GLUCOSE	Pressure	1
CELLOB --> GLUCOSE	(atm)	
<b>Fermentation</b>		
GLUCOSE --> 2 ETHANOL + 2 CO <sub>2</sub>	Temperature	41
GLUCOSE + 0.04696 CSL + 0.018 DAP --> 6 ZYMO	(°C)	
+ 2.4 H <sub>2</sub> O	Pressure	1
GLUCOSE + 2 H <sub>2</sub> O --> 2 GLYCEROL + O <sub>2</sub>	(atm)	
GLUCOSE + 2 CO <sub>2</sub> --> 2 SUCCACID + O <sub>2</sub>		
GLUCOSE --> 3 AACID		
GLUCOSE --> 2 LACID		
3 XYLOSE --> 5 ETHANOL + 5 CO <sub>2</sub>		
XYLOSE + 0.03913 CSL + 0.015 DAP --> 5 ZYMO +		
2 H <sub>2</sub> O		

<p>3 XYLOSE + 5 H2O --&gt; 5 GLYCEROL + 2.5 O2</p> <p>XYLOSE + H2O --&gt; XYLITOL + 0.5 O2</p> <p>3 XYLOSE + 5 CO2 --&gt; 5 SUCCACID + 2.5 O2</p> <p>2 XYLOSE --&gt; 5 AACID</p> <p>3 XYLOSE --&gt; 5 LACID</p> <p>3 ARABINOS --&gt; 5 ETHANOL + 5 CO2</p> <p>ARABINOS + 0.03913 CSL + 0.015 DAP --&gt; 5 ZYMO + 2 H2O</p> <p>3 ARABINOS + 5 H2O --&gt; 5 GLYCEROL + 2.5 O2</p> <p>3 ARABINOS + 5 CO2 --&gt; 5 SUCCACID + 2.5 O2</p> <p>2 ARABINOS --&gt; 5 AACID</p> <p>3 ARABINOS --&gt; 5 LACID</p> <p>3 GALACTOS --&gt; 6 ETHANOL + 6 CO2</p> <p>GALACTOS + 0.04696 CSL + 0.018 DAP --&gt; 6 ZYMO + 2.4 H2O</p> <p>GALACTOS + 2 H2O --&gt; 2 GLYCEROL + O2</p> <p>GALACTOS + 2 CO2 --&gt; 2 SUCCACID + O2</p> <p>GALACTOS --&gt; 3 AACID</p> <p>GALACTOS --&gt; 2 LACID</p> <p>MANNOSE --&gt; 2 ETHANOL + 2 CO2</p> <p>MANNOSE + 0.04696 CSL + 0.018 DAP --&gt; 6 ZYMO + 2.4 H2O</p> <p>MANNOSE + 2 H2O --&gt; 2 GLYCEROL + O2</p> <p>MANNOSE + 2 CO2 --&gt; 2 SUCCACID + O2</p> <p>MANNOSE --&gt; 3 AACID</p> <p>MANNOSE --&gt; 2 LACID</p>		
--	--	--

### A.3 Detailed description of equation 6.2 Sukumara *et al.* 2013[A modified version of Faulkner 2012].

$$\text{Maximize Profit} = \sum_{m=1}^{12} (\text{Sales}_m - \text{Cost}_m)$$

$$\text{Sales}_m = \sum_{p=1}^P P_{pm} P P_p$$

$$\text{Cost}_m = BC_m + BC'_m + BC''_m + BC'''_m + OC_m + PC_m + PC'_m$$

$$BC_m = \sum_{f=1}^F \sum_{i=1}^I \sum_{j=1}^J X_{fijm} B P_f$$

$$OC_m = ELEC_m + COOL_m + HEAT_m + LC_m + SC_m + MC_m + OVC_m + ACC_m$$

$$BC'_m = \sum_{f=1}^F \sum_{i=1}^I \sum_{j=1}^J X_{fijm} R$$

$$PC_m = \sum_{p=1}^P \sum_{j=1}^J \sum_{k=1}^K 2T_{pjkm} d_{jk} (PTC + sPTC')$$

$$BC''_m = \sum_{f=1}^F \sum_{i=1}^I \sum_{j=1}^J 2T_{fijm} d_{ij} (BTC + \frac{BTC'}{s})$$

$$PC'_m = \sum_{p=1}^P \sum_{j=1}^J \sum_{k=1}^K kT_{pjkm} d_{jk} (2TM + TM'_p) DP$$

$$BC'''_m = \sum_{f=1}^F \sum_{i=1}^I \sum_{j=1}^J kT_{fijm} d_{ij} (2TM + TM'_f) DP$$

$$\frac{X_{fijm}}{TM'_f} = T_{fijm} \forall f, i, j, m$$

$$\frac{Y_{pjkm} \rho_p}{2000TM'_f} = T_{pjkm} \forall f, j, k, m$$

**Subject to:**

$$\sum_{j=1}^J P_j = 1$$

$$Y_{pjkm}, X_{fijm} \geq 0$$

$$\sum_{j=1}^J X_{fijm} \leq B''_{fim} \forall f, i, m$$

$$P_j = \text{binary}$$

$$B_{fim} = B''_{fim} \forall f, i, \& m = 1$$

$$B_{fim} + B'_{fim} = B''_{fim} \forall f, i, \& m = 2..12$$

$$E_f \left( B''_{fim-1} - \sum_{j=1}^J X_{fijm-1} \right) = B'_{fim} \forall f, i, \& m = 2..12$$

$$\sum_{i=1}^I \sum_{j=1}^J X_{fijm} = BN_{fm} \forall f, m$$

$$\sum_{j=1}^J \sum_{k=1}^K Y_{pjkm} = PS_{pjm} \forall m, p$$

$$\sum_{j=1}^J Y_{pjkm} \leq PD_{pkm} \forall p, k, m$$

$$\sum_{f=1}^F \sum_{i=1}^I \sum_{j=1}^J \sum_{m=1}^M X_{fijm} \leq MP_j \forall j$$

$$\sum_{p=1}^P \sum_{j=1}^J \sum_{k=1}^K \sum_{m=1}^M Y_{pjkm} \leq MP_j \forall j$$

**Decision Variables:**

$P_j$ : the selection of a biorefinery at location (j)

$X_{fijm}$ : the amount of feedstock (f) to be transported from biomass feedstock location (i) to biorefinery location (j) in month (m)

$Y_{pjk m}$ : the amount of product (p) to be transported from biorefinery location (j) to market distribution location (k) in month (m)

**Subscript indices:**

$F$ = Number of biomass feedstock

$P$  = Number of product

$I$ = Number of biomass location

$J$  = Number of plant location

$K$ = Number of product location

$M$ = Month

**Parameters:**

$P_{pm}$  = products created in that month

$PP_p$  = price of the product

$BP_f$  = price of biomass

$BC_m$  = monthly biomass purchasing cost

$BC'_m$  = monthly biomass inventory cost

$BC''_m$  = monthly biomass transportation cost

$BC'''_m$  = monthly cost of diesel to transport the biomass

$OC_m$  = monthly operating cost

$PC_m$  = monthly product transportation cost

$PS$  = amount of products created

$PC'_m$  = monthly product transportation diesel cost

$ELEC_m$  = monthly biorefinery electricity cost

$COOL_m$  = monthly biorefinery cooling cost

$HEAT_m$  = monthly biorefinery heating cost

$LC_m$  = monthly labor cost

$R$  = biomass land rent cost

$T$  = number of trucks

$SC_m$  = monthly supervisor cost

$MC_m$  = monthly maintenance cost

$MC'_m$  = monthly maintenance cost conversion

$OVC_m$  = monthly overhead cost

$ACC_m$  = monthly annualized capital cost

$DP$  = diesel price

$TM$  = truck mass

$TM'$  = biomass truck capacity

$TM''$  = product truck capacity

$BTC$  = distance dependent cost

$BTC'$  = time dependent cost of transportation

$PTC$  = product distance dependent cost

## Appendix B

### B.1 Process conditions for feed flexible gasification

<b>Major units</b>	<b>Process</b>	<b>Temperature (°C)</b>	<b>Pressure (atm)</b>
<b>Sizing</b>	Size reduction	30	1
	Screening	30	1
<b>Gasification</b>	Decomposition*	30	1
	Gasifier	800-1500	1
<b>Cleaning</b>	Absorption Column	-36	1
	Flash	5	1
<b>WGS</b>	WGS Reactor	245	1
<b>FTS</b>	FTS Reactor	250	14.6
<b>Power Generation</b>	Generator	-	-
<b>Product Separation</b>	Distillation column 1	197	1
	Distillation Column 2	231	1.5

Note: \*This reactor is included for simulation purposes only. The purpose of this reactor is to break down incoming biomass into its elemental composition based on proximate and ultimate analysis data.

## B.2 Summary of capital costs

Table B.1 Summary of capital cost for the case study on biomass gasification

PROJECT CAPITAL SUMMARY	Small	Medium	Large
<b>Purchased Equipment</b>	\$8,200,700	\$12,094,301	\$15,590,701
<b>Equipment Setting</b>	\$159,578	\$200,625	\$239,433
<b>Piping</b>	\$1,907,202	\$2,097,990	\$2,255,200
<b>Civil</b>	\$542,537	\$649,621	\$650,297
<b>Steel</b>	\$259,188	\$281,002	\$292,584
<b>Instrumentation</b>	\$2,465,383	\$2,487,310	\$2,518,098
<b>Electrical</b>	\$1,085,698	\$1,220,049	\$1,336,351
<b>Insulation</b>	\$636,139	\$645,740	\$735,883
<b>Paint</b>	\$135,880	\$160,480	\$155,063
<b>Other</b>	\$8,826,801	\$9,660,101	\$10,331,001
<b>Subcontracts</b>	-	-	-
<b>G and A Overheads</b>	\$578,487	\$730,791	\$864,951
<b>Contract Fee</b>	\$914,975	\$1,040,869	\$1,149,169
<b>Escalation</b>	-	-	-
<b>Contingencies</b>	\$4,628,262	\$5,628,398	\$6,501,370
<b>Total Project Cost</b>	\$30,340,829	\$36,897,276	\$42,620,101
<b>Adjusted Total Project Cost</b>	\$29,974,072	\$36,451,265	\$42,104,913

## B.3 (a) Variable feed costs

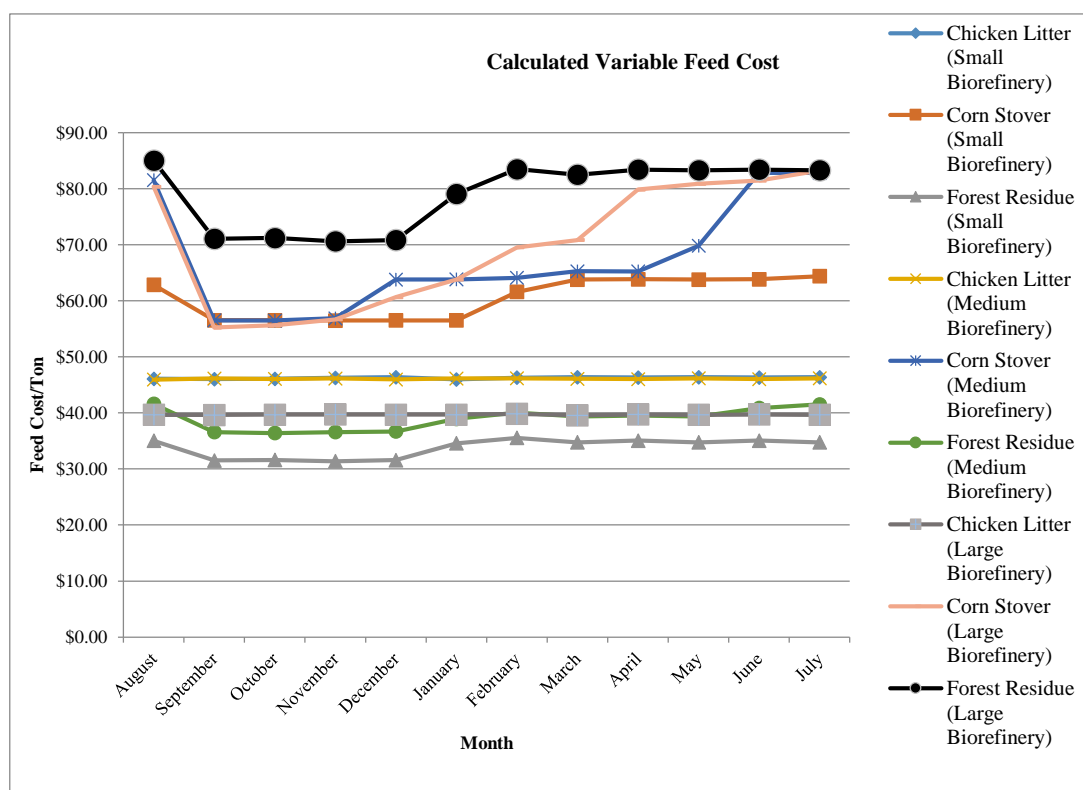

Figure B.3.a Monthly variable feed cost (including process and transportation) at the biorefinery location for various raw materials.

### B.3 (b) Varying utility costs

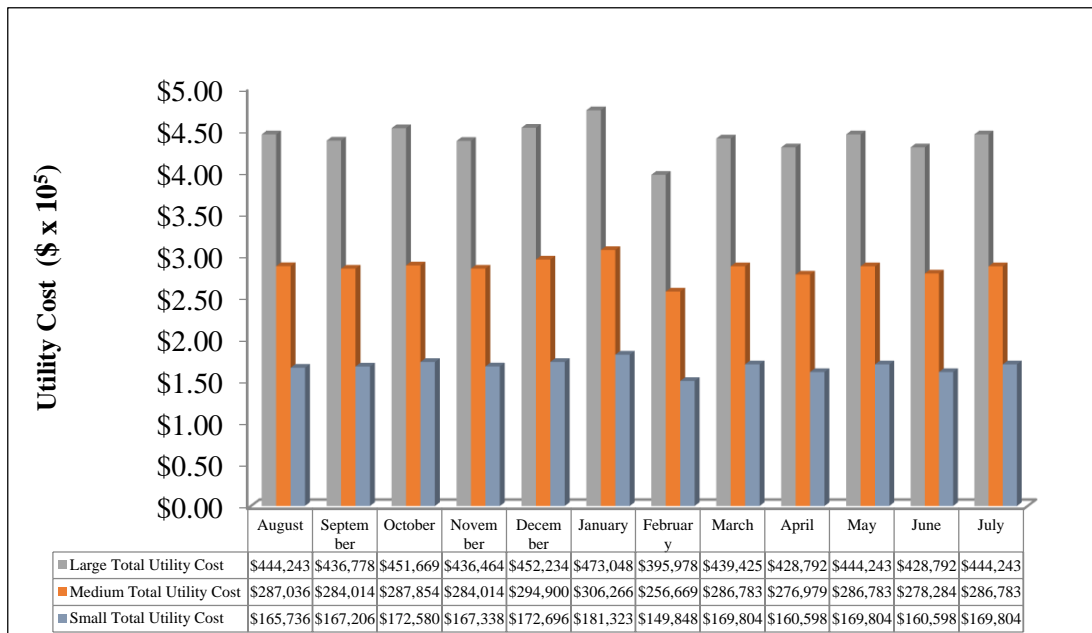

Figure B.3.b Monthly variable utility cost for Large, Medium and Small biorefinery

### B.4 Cumulative yearly cash flow including capital investment

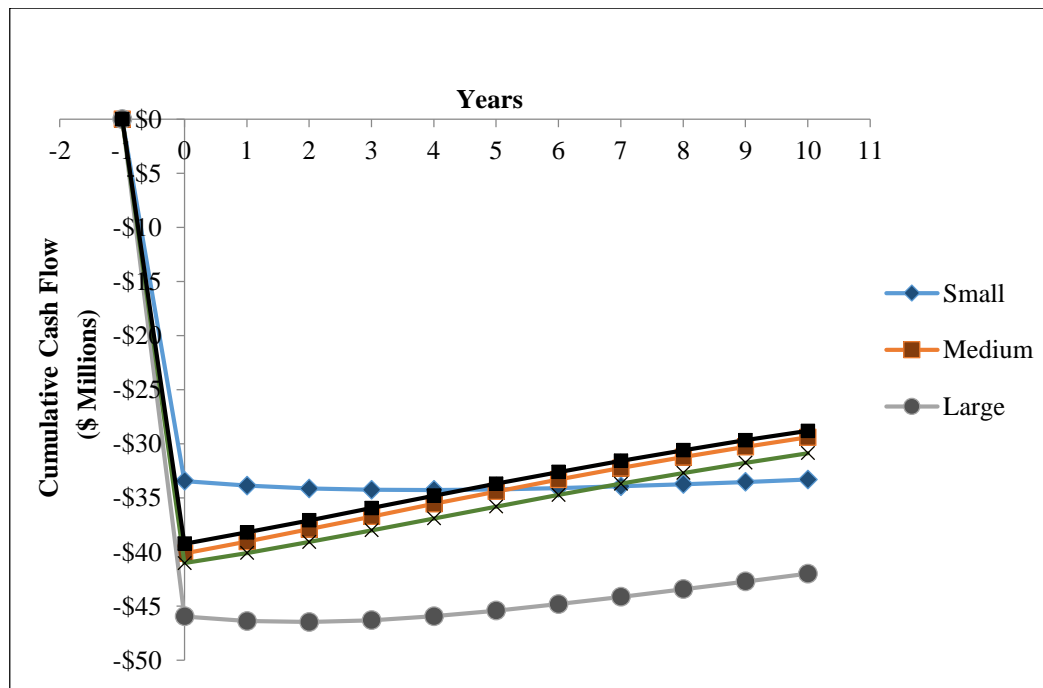

Figure B.4 Cumulative cash flows for various trial capacities



## B.5 Potential environmental impact comparison using the Waste Reduction

### Algorithm

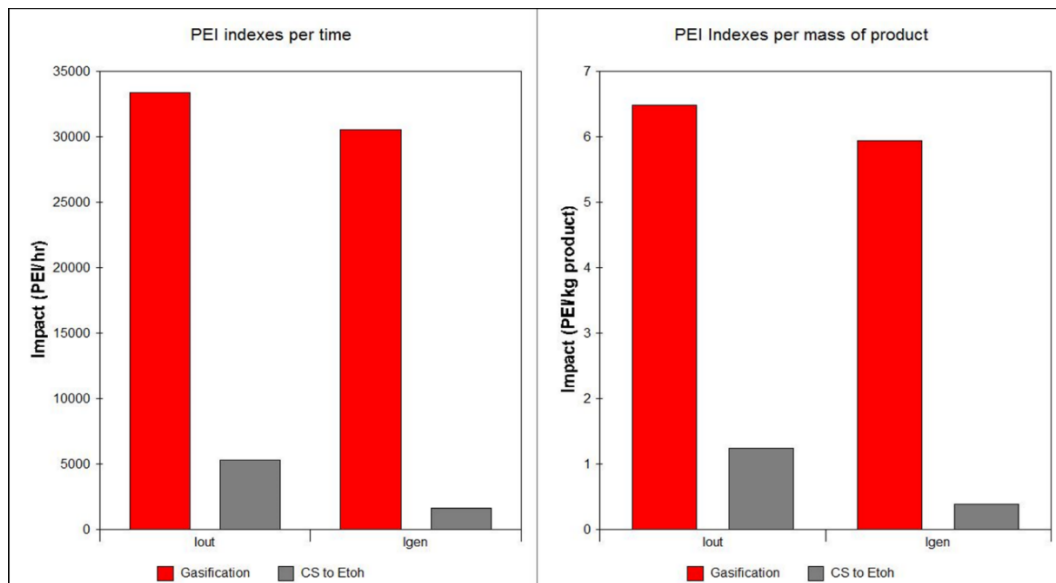

Figure B.5 Potential Environmental Impacts of thermochemical and biochemical processes

## B.6 Jobs created for the biochemical conversion process

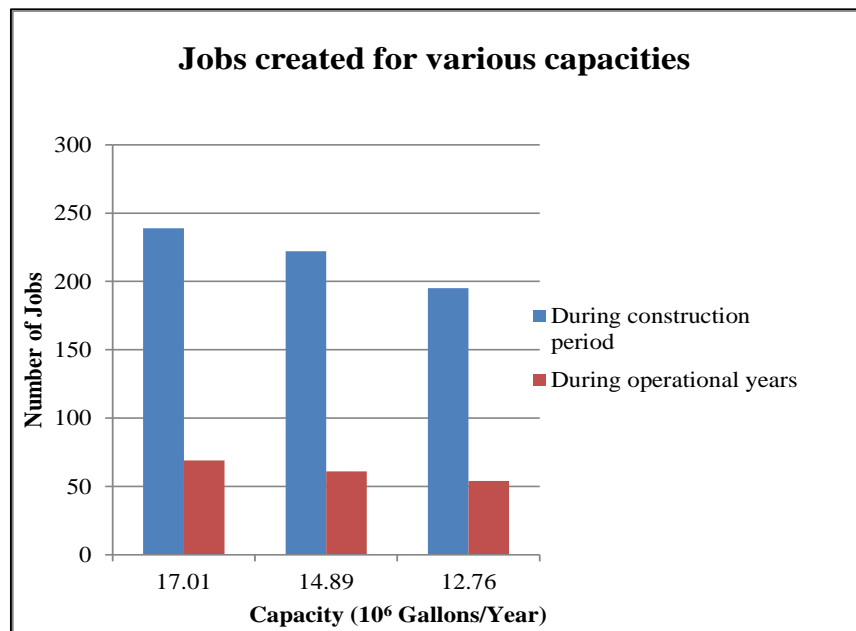

Figure B.6 Constructional and operational jobs created for three capacities of biorefinery based on biochemical conversion process

## Appendix C

### C.1 Equations and notations used for showing the objective function and constraints

$$BOC = \text{Variable Feed Cost}(VFC) + \text{Chemicals Cost}(CC) + \text{Utility Cost}(UC) \quad (2)$$

Where,

$$PSI = \sum_{h=1}^a C_h P_h, \quad VFC = \sum_{w=1}^b B_w F_w, \quad CC = \sum_{v=1}^d Q_v G_v$$

$$UC = CH \sum_{x=1}^e QH_x + CR \sum_{y=1}^f QR_y + CC \sum_{z=1}^g QC_z$$

Subject to:

$$A = CL * O_p, \quad D = FR * O_q, \quad R = CS * O_r$$

$$0.9 \leq O_p \leq 1, \quad 0.9 \leq O_q \leq 1, \quad 0.9 \leq O_r \leq 1$$

Notations and subscript indices

$C_h, B_w, Q_v$	Product (\$/gal), feed (\$/kg) and chemical (\$/kg) unit cost, respectively
$P_h, F_w, G_v$	Product (gal/s), feed (kg/s) and chemical (kg/s) flow rate, respectively
$CH, CR, CC$	Cost of hot, refrigeration and cold utility, respectively (\$/J)
$QH_x, QR_y, QC_z$	Hot, refrigerant and cold utility consumed (W)
$CL, FR, CS$	Generated chicken litter, forest residue and corn stover (kg/sec)
$A, D, R$	Rate of input of $CL, FR$ and $CS$ , respectively (kg/sec)
$O_p, O_q, O_r$	Non-negative multiplication factor of $CL, FR$ and $CS$ , respectively
$a, b, d$	Number of product, feedstock and chemicals, respectively
$e, f, g$	Number of hot, refrigeration and cold utility streams, respectively

**C.2 Feed data discussed in section 7.6 to begin various iterations for the case study**

Table C.1 Feed availability assumptions for the marginal land case study to begin iterations in order to find the optimum configuration

	Case 1 (Wet Tons)	Case 2 (Wet Tons)	Case 3 (Wet Tons)	Case 4 (Wet Tons)
<b>January</b>	59024	46598	31065	15532
<b>February</b>	60078	47430	31620	15810
<b>March</b>	53269	42055	28036	14018
<b>April</b>	50606	39952	26634	13317
<b>May</b>	48076	37954	25303	12651
<b>June</b>	47194	37258	24839	12419
<b>July</b>	39189	30939	20626	10313
<b>August</b>	38385	30304	20202	10101
<b>September</b>	34197	26998	17998	8999
<b>October</b>	61660	48679	32452	16226
<b>November</b>	65401	51632	34421	17210
<b>December</b>	62131	49051	32700	16350

## Appendix D

### D.1 Predicted optimum configuration based on the preliminary assessment

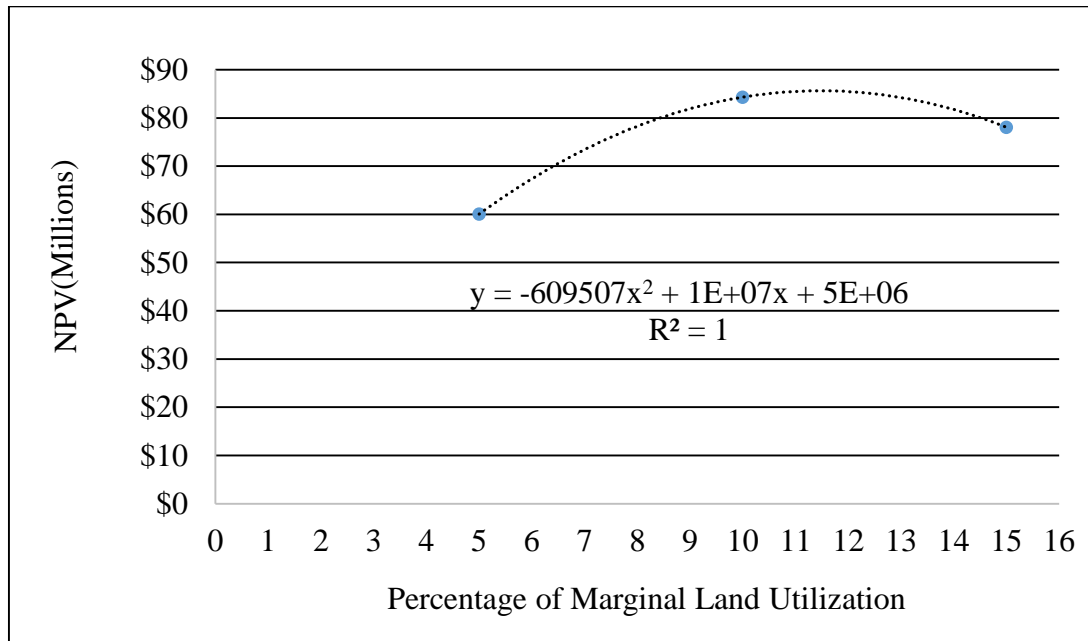

Figure D.1 Preliminary optimum prediction based on process and supply chain optimization results

### D.2 FORTRAN code used to incorporate the user specified into the process simulation based on the kinetics from the literature (Kadam *et al.* 2004)

Code:

```
SUBROUTINE LHUKIN (SOUT, NSUBS, IDXSUB, ITYPE, NINT,  
1 INT, NREAL, REAL, IDS, NPO,  
2 NBOPST, NIWORK, IWORK, NWORK, WORK,  
3 NC, NR, STOIC, RATES, FLUXM,  
4 FLUXS, XCURR, NTCAT, RATCAT, NTSSAT,  
5 RATSSA, KCALL, KFAIL, KFLASH, NCOMP,  
6 IDX, Y, X, X1, X2,  
7 NRALL, RATALL, NUSERV, USERV, NINTR,  
8 INTR, NREALR, REALR, NIWR, IWR,  
9 NWR, WR)  
!  
!  
! IMPLICIT NONE  
!  
! DECLARE VARIABLES USED IN DIMENSIONING  
!  
! INTEGER NSUBS, NINT, NPO, NIWORK, NWORK,
```

```

+      NC,      NR,      NTCAT, NTSSAT, NCOMP,
+      NRALL,  NUSERV, NINTR, NREALR, NIWR,
+      NWR

!-----
#include "rcst_rcstri.cmn"
#include "rxn_rcstrr.cmn"

!- RPLUG
#include "rplg_rplugi.cmn"
#include "rplg_rplugr.cmn"
      EQUIVALENCE (XLEN, RPLUGR_UXLONG)
      EQUIVALENCE (DIAM, RPLUGR_UDIAM)

!- RBATCH
#include "rbtc_rbati.cmn"

!- Pressure Relief
#include "rbtc_presrr.cmn"

!-----
#include "rxn_rprops.cmn"
      EQUIVALENCE (TEMP, RPROPS_UTEMP)
      EQUIVALENCE (PRES, RPROPS_UPRES)
      EQUIVALENCE (VFRAC, RPROPS_UVFRAC)
      EQUIVALENCE (BETA, RPROPS_UBETA)
      EQUIVALENCE (VVAP, RPROPS_UVVAP)
      EQUIVALENCE (VLIQ, RPROPS_UVLIQ)
      EQUIVALENCE (VLIQS, RPROPS_UVLIQS)
#include "pput1_ppglob.cmn"

!-----
#include "ppexec_user.cmn"
      EQUIVALENCE (RMISS, USER_RUMISS)
      EQUIVALENCE (IMISS, USER_IUMISS)

!-----
#include "dms_errout.cmn"
      EQUIVALENCE (IERROUT, ERRROUT_IEROUT)

      INTEGER IDXSUB(NSUBS), ITYPE(NSUBS), INT(NINT),
+      IDS(2), NBOPST(6, NPO), IWORK(NIWORK),
+      IDX(NCOMP), INTR(NINTR), IWR(NIWR),
+      NREAL, KCALL, KFAIL, KFLASH, I,
+      ICELL, ICLIG, IGLUC, IH2O, IPCELL
      INTEGER IPCLIG, IPGLUC, IPH2O, KV, KDIAG,
+      KER
      REAL*8 SOUT(1), WORK(NWORK),
+      STOIC(NC, NSUBS, NR), RATES(NC),
+      FLUXM(1), FLUXS(1), RATCAT(NTCAT),
+      RATSSA(NTSSAT), Y(NCOMP),
+      X(NCOMP), X1(NCOMP), X2(NCOMP)
      REAL*8 RATALL(NRALL), USERV(NUSERV),
+      REALR(NREALR), WR(NWR), XCURR, TEMP,
+      PRES, VMXL, DVMX, TK

!

      INTEGER IPROG(2), IMISS, DMS_KFORMC, DMS_IRRCHK
      REAL*8 REAL(NREAL), XLEN, DIAM, VFRAC, BETA,
+      VVAP, VLIQ, VLIQS, RMISS, CCELL,
+      CCLIG, CGLUC, CH2O, RRATE1, RRATE2, RRATE3,
+      RNET

```

```

CHARACTER*80 IERROUT(10), IERW1(10), IERW2(9), IERW3(8)
+           , IERW4(7), IERW5(6), IERW6(5), IERW7(4), IERW8(3)
+           , IERW9(2), IERW10

EQUIVALENCE (IERROUT(1), IERW1), (IERROUT(2), IERW2),
+           (IERROUT(3), IERW3), (IERROUT(4), IERW4),
+           (IERROUT(5), IERW5), (IERROUT(6), IERW6),
+           (IERROUT(7), IERW7), (IERROUT(8), IERW8),
+           (IERROUT(9), IERW9), (IERROUT(10), IERW10)

!
DATA IPROG /4HUSRK, 4HIN /

!=====
=

50      FORMAT(T15,'Total Molar Flow: ',d14.7,/,
+           T15,'Realr(1-6):      ',d14.7,(' ',d14.7),/,
+           T33,                    d14.7,(' ',d14.7),/,
+           T15,'Rgas:              ',d14.7,/,
+           T15,'Tk (K):            ',d14.7,/,
+           T15,'Rnet:              ',d14.7,/,
+           T15,'Vvap:              ',d14.7,/,
+           T15,'Vliq:              ',d14.7,/,
+           T15,'Overall Component Rate (kmol/sec): ',d14.7 )
60      FORMAT(T17,'Component Data ',/,
+           T20,'Cellulose Mole Fraction: ',F10.4,/,
+           T32,'Conc (kmol/m3): ',F10.4,/,
+           T20,'Cellobiose Mole Fraction: ',F10.4,/,
+           T32,'Conc (kmol/m3): ',F10.4,/,
+           T20,'Glucose Mole Fraction: ',F10.4,/,
+           T32,'Conc (kmol/m3): ',F10.4,/,
+           T20,'Water Mole Fraction: ',F10.4,/,
+           T32,'Conc (kmol/m3): ',F10.4,/,
+           T20,'Density (m3/kgmol): ',F10.4)

!
! BEGIN EXECUTABLE CODE
!
DO I = 1, NC
  RATES(I) = 0.
END DO

!=====
=

ICELL =DMS_KFORMC ('C2H4O2-1')
ICLIG =DMS_KFORMC ('C2H6O-2')
IGLUC =DMS_KFORMC ('C4H8O2-3')
IH2O  =DMS_KFORMC ('H2O')

!=====
=

DO I=1, NCOMP
  IF (IDX(I).EQ.ICELL) THEN
    IPCELL=I
  ELSE IF (IDX(I).EQ.ICLIG) THEN
    IPCLIG=I
  ELSE IF (IDX(I).EQ.IGLUC) THEN
    IPGLUC=I
  ELSE IF (IDX(I).EQ.IH2O) THEN

```

```

                IPH20=I
            END IF
        END DO

!=====
=

        KV=1
        CALL PPMON_VOLL ( TEMP , PRES , X , NCOMP , IDX, NBOPST,
+           KDIAG, KV, VMXL, DVMX, KER )

        CCELL = X(IPCELL)/VMXL
        CCLIG = X(IPCLIG)/VMXL
        CGLUC = X(IPGLUC)/VMXL
        CH20 = X(IPH20)/VMXL

!=====
=

        TK=TEMP
        RRATE1 = REALR(1)*(TK/318)*EXP((-REALR(2)/(PPGLOB_RGAS))*((1/TK)-
+ (1/318)))*((0.00001768687*CCELL**3)/
+ (1+(66.66*CCLIG)+(10*CGLUC)))
        RRATE2 = REALR(3)*(TK/318)*EXP((-REALR(4)/(PPGLOB_RGAS))*((1/TK)-
+ (1/318)))*((0.00001770354*CCELL**3)/
+ (1+(0.007575*CCLIG)+(25*CGLUC)))
        RRATE3 = REALR(5)*(TK/318)*EXP((-REALR(6)/(PPGLOB_RGAS))*((1/TK)-
+ (1/318)))*((0.001*CCLIG**1)/
+ (24.3+CCLIG+(6.23*CGLUC)))

        RNET = -RRATE3 - RRATE2

!=====
=

        RATES(ICELL) = (-RRATE1 - RRATE2)*VLIQ
        RATES(ICLIG) = ((1.056*RRATE1) - RRATE3)*VLIQ
        RATES(IGLUC) = ((1.111*RRATE2) + (1.053*RRATE3))*VLIQ
        RATES(IH20) = RNET*VLIQ

!=====
=
! Diagnostic Section

        IF(DMS_IRRCHK(IPROG,5,9001,USER_LMSG,IMISS,0,0,2) .NE. 0)
+           THEN

                WRITE(IERROUT, 50) SOUT(NC+1), REALR(1), REALR(2)
+           , REALR(3), REALR(4)
+           , PPGLOB_RGAS, TK, RNET, VVAP, VLIQS
!           +           DABS(RATES(IGLUC))

                CALL DMS_ERRPRT(10)
            END IF

!-----
        IF(DMS_IRRCHK(IPROG,6,9002,USER_LMSG,IMISS,0,0,2) .NE. 0)
+           THEN

```

```
WRITE(IERW1, 60) X(IPCELL), CCELL, X(IPCLIG),  
CCLIG, X(IPGLUC), CGLUC, X(IPH20), CH20, VMXL
```

```
CALL DMS_ERRPRT(10)
```

```
END IF  
RETURN  
END
```

```
!=====  
=
```



## D.3 Snapshots showing the methodology of accessing the simulation and the optimization models from the Microsoft Excel® interface.

(a) Running and accessing data from Aspen Plus®

The screenshot displays an Excel spreadsheet with the following data sections:

- Material Inputs:** Lists items like CS, CL, FR, WATER1, ARI1, CH4, MECH1, MECH2, WATER2, AIR2, and CO2(aque) with their respective amounts and units.
- Material Pricing Inputs:** Lists items like CS, CL, FR, WATER1, ARI1, CH4, MECH1, MECH2, WATER2, AIR2, and CO2(aque) with their prices per unit.
- Material Outputs:** Lists items like NATGAS, HEAVY, GASOLINE, DIESEL, ASH-STOR, H2S(aq), WATER3, H2O-TRAP, and CO2 Emission with their amounts and units.
- Heat and Utilities Pricing Inputs:** Lists items like COOLING, ELECTRIC, HHV, HPSTEAM, LPSTEAM, and MPSTEAM with their prices.
- Heat and Utilities Outputs:** Lists items like Heating, Cooling, ELECTRIC, HHV, HPSTEAM, LPSTEAM, and MPSTEAM with their amounts and units.
- Utilities Outputs:** Lists items like COOLING, ELECTRIC, HHV, HPSTEAM, LPSTEAM, and MPSTEAM with their prices.
- Optimum Input Amounts (Output):** Lists items like CS, CL, and FR with their optimized amounts.
- Input Streams:** Tables for CS Input, CL Input, and FR Input showing Name, Value, Units, Status, Variable Name, Object ID, Container, and Component.
- Block Specifications:** A central section for defining process blocks.
- Output/Waste Streams:** Tables for NATGAS Output, HEAVY Output (liquid only), and GASOLINE Output showing Name, Value, Units, Status, Variable Name, Object ID, Container, and Component.

(b) Transposing the Data in the format acceptable by ILOG OPL®

The screenshot displays an Excel spreadsheet with the following data sections:

- Feedstock:**
  - CL (ton): 23,677,303.51 to 733,996.4
  - FR (ton): 39,753,046.21 to 1,232,344.4
  - SW (ton): 1113.085 to 1,232,344.4
- Products:**
  - Natural gas (Mcf): 95,835,170.55 to 29,708.89
  - Gasoline (gal): 1,108,170,691.34 to 3,324,512.34
  - Diesel (gal): 4,248,550,084.13 to 1,189,594.4
  - Heavy (gal): 2,770,957.4 to 8,589.68
  - Electricity (MWhr): 24,727,280.16 to 766,545.7
- Utilities (\$):**
  - Cold: 540.04 to 16,741.37
  - Elec: 3,955.44 to 12,261.74
  - hot1: 229.97 to 7,128.97
  - hot2: 621.32 to 19,260.90



## References

1. EIA. *Monthly Energy Review*. 2014 [cited 2014 July]; Available from: <http://www.eia.gov/todayinenergy/detail.cfm?id=16511&src=Total-b1>.
2. EIA, *International Energy Outlook*. 2013, U.S. Energy Information Administration: Washington DC, USA.
3. NREL. *What is a Biorefinery?* 2009 [cited 2014 9 July]; Available from: <http://www.nrel.gov/biomass/biorefinery.html>.
4. Lipinsky, E.S., *Chemicals from Biomass: Petrochemical Substitution Options*. Science, 1981. **212**(4502): p. 1465-1471.
5. Rentizelas, A., et al., *Comparative techno-economic analysis of ORC and gasification for bioenergy applications*. Energy Conversion and Management, 2009. **50**(3): p. 674-681.
6. DOE. *Integrated Biorefineries*. 2014 [cited 2014 9 July]; Available from: [http://www1.eere.energy.gov/bioenergy/pdfs/ibr\\_portfolio\\_overview.pdf](http://www1.eere.energy.gov/bioenergy/pdfs/ibr_portfolio_overview.pdf).
7. Menichetti, E. and M. Otto, *Energy balance and greenhouse gas emissions of biofuels from a life-cycle perspective*. Biofuels: environmental consequences and interactions with changing land use, Proceedings of the Scientific Committee on Problems of the Environment (SCOPE) International Biofuels Project Rapid Assessment, 2008: p. 22-25.
8. von Blottnitz, H. and M.A. Curran, *A review of assessments conducted on bio-ethanol as a transportation fuel from a net energy, greenhouse gas, and environmental life cycle perspective*. Journal of Cleaner Production, 2007. **15**(7): p. 607-619.
9. Center, B.E. *Why Use Biomass*. 2014 [cited 2014 25 July]; Available from: [http://www.biomassenergycentre.org.uk/portal/page?\\_pageid=76,15068&\\_dad=portal&\\_schema=PORTAL](http://www.biomassenergycentre.org.uk/portal/page?_pageid=76,15068&_dad=portal&_schema=PORTAL).
10. McKendry, P., *Energy production from biomass (part 1): overview of biomass*. Bioresource Technology, 2002. **83**(1): p. 37-46.
11. Demirbaş, A., *Biomass resource facilities and biomass conversion processing for fuels and chemicals*. Energy Conversion and Management, 2001. **42**(11): p. 1357-1378.
12. Nigam, P.S. and A. Singh, *Production of liquid biofuels from renewable resources*. Progress in Energy and Combustion Science, 2011. **37**(1): p. 52-68.
13. Cherubini, F. and A.H. Strømman, *Life cycle assessment of bioenergy systems: State of the art and future challenges*. Bioresource Technology, 2011. **102**(2): p. 437-451.
14. Cherubini, F., *The biorefinery concept: Using biomass instead of oil for producing energy and chemicals*. Energy Conversion and Management, 2010. **51**(7): p. 1412-1421.
15. Chundawat, S.P.S., et al., *Deconstruction of Lignocellulosic Biomass to Fuels and Chemicals*. Annual Review of Chemical and Biomolecular Engineering, 2011. **2**(1): p. 121-145.

16. Himmel, M.E., et al., *Biomass Recalcitrance: Engineering Plants and Enzymes for Biofuels Production*. Science, 2007. **315**(5813): p. 804-807.
17. Gold, S. and S. Seuring, *Supply chain and logistics issues of bio-energy production*. Journal of Cleaner Production, 2011. **19**(1): p. 32-42.
18. Mafakheri, F. and F. Nasiri, *Modeling of biomass-to-energy supply chain operations: Applications, challenges and research directions*. Energy Policy, 2014. **67**(0): p. 116-126.
19. EPA Office of Transportation and Air Quality (OTAQ). *Renewable Fuel Standard (RFS)*. 2007; Available from: <http://www.epa.gov/otaq/fuels/renewablefuels/index.htm>.
20. Balan, V., D. Chiaramonti, and S. Kumar, *Review of US and EU initiatives toward development, demonstration, and commercialization of lignocellulosic biofuels*. Biofuels, Bioproducts and Biorefining, 2013. **7**(6): p. 732-759.
21. Sukumara, S., et al., *A multidisciplinary decision support tool for evaluating multiple biorefinery conversion technologies and supply chain performance*. Clean Technologies and Environmental Policy, 2013: p. 1-18.
22. Faulkner, W.H., *Economic Modeling & Optimization of a Region Specific Multi-feedstock Biorefinery Supply Chain*, in *Manufacturing Systems Engineering*. 2012, University of Kentucky: Lexington, KY, USA.
23. Brundtland, G.H., *Global Change and Our Common Future*. Environment: Science and Policy for Sustainable Development, 1989. **31**(5): p. 16-43.
24. Burton, I., *Report on Reports: Our Common Future: The World Commission on Environment and Development*. Environment: Science and Policy for Sustainable Development, 1987. **29**(5): p. 25-29.
25. Azapagic, A., *Sustainability considerations for integrated biorefineries*. Trends in Biotechnology, 2014. **32**(1): p. 1-4.
26. Jeffrey, R.S. and R.E. Mario, *Incorporating Sustainability and Environmental Impact Assessment into Capstone Design Projects*, in *Design for Energy and the Environment*. 2009, CRC Press. p. 689-697.
27. Fleischmann, B., H. Meyr, and M. Wagner, *Advanced Planning*, in *Supply Chain Management and Advanced Planning*, H. Stadler and C. Kilger, Editors. 2005, Springer Berlin Heidelberg. p. 81-106.
28. Rødsrud, G., M. Lersch, and A. Sjöde, *History and future of world's most advanced biorefinery in operation*. Biomass and Bioenergy, 2012. **46**(0): p. 46-59.
29. Naik, S.N., et al., *Production of first and second generation biofuels: A comprehensive review*. Renewable and Sustainable Energy Reviews, 2010. **14**(2): p. 578-597.
30. Lee, R.A. and J.-M. Lavoie, *From first-to third-generation biofuels: Challenges of producing a commodity from a biomass of increasing complexity*. Animal Frontiers, 2013. **3**(2): p. 6-11.
31. Hamelinck, C.N., G.v. Hooijdonk, and A.P.C. Faaij, *Ethanol from lignocellulosic biomass: techno-economic performance in short-, middle- and long-term*. Biomass and Bioenergy, 2005. **28**(4): p. 384-410.

32. Lu, J., C. Sheahan, and P. Fu, *Metabolic engineering of algae for fourth generation biofuels production*. Energy & Environmental Science, 2011. **4**(7): p. 2451-2466.
33. Demirbas, A. and M.F. Demirbas, *Energy from Algae*, in *Algae Energy*. 2010, Springer London. p. 97-138.
34. Bridgwater, A.V., *The technical and economic feasibility of biomass gasification for power generation*. Fuel, 1995. **74**(5): p. 631-653.
35. Tijmensen, M.J.A., et al., *Exploration of the possibilities for production of Fischer Tropsch liquids and power via biomass gasification*. Biomass and Bioenergy, 2002. **23**(2): p. 129-152.
36. Maschio, G., C. Koufopoulos, and A. Lucchesi, *Pyrolysis, a promising route for biomass utilization*. Bioresource Technology, 1992. **42**(3): p. 219-231.
37. Brown, R., *Hybrid thermochemical/biological processing*. Applied Biochemistry and Biotechnology, 2007. **137-140**(1-12): p. 947-956.
38. Roger, R., et al., *Size matters: small distributed biomass energy production systems for economic viability*. International Journal of Agricultural and Biological Engineering, 2008. **1**(1): p. 5.
39. Richard, T.L., *Challenges in scaling up biofuels infrastructure*. Science(Washington), 2010. **329**(5993): p. 793-796.
40. Yue, D., F. You, and S.W. Snyder, *Biomass-to-bioenergy and biofuel supply chain optimization: Overview, key issues and challenges*. Computers & Chemical Engineering, 2014(0).
41. Zhu, X., et al., *Challenges and models in supporting logistics system design for dedicated-biomass-based bioenergy industry*. Bioresource Technology, 2011. **102**(2): p. 1344-1351.
42. Foust, T.D., *A National Laboratory market and technology assessment of the 30x30 scenario*. 2007: National Renewable Energy Laboratory.
43. Hess, J.R., C.T. Wright, and K.L. Kenney, *Cellulosic biomass feedstocks and logistics for ethanol production*. Biofuels, Bioproducts and Biorefining, 2007. **1**(3): p. 181-190.
44. Aksoy, B., et al., *Identification of optimal poultry litter biorefinery location in Alabama through minimization of feedstock transportation cost*. Environmental Progress, 2008. **27**(4): p. 515-523.
45. Kang, S., et al., *Optimizing the Biofuels Infrastructure: Transportation Networks and Biorefinery Locations in Illinois*, in *Handbook of Bioenergy Economics and Policy*, M. Khanna, J. Scheffran, and D. Zilberman, Editors. 2010, Springer New York. p. 151-173.
46. An, H., W.E. Wilhelm, and S.W. Searcy, *Biofuel and petroleum-based fuel supply chain research: A literature review*. Biomass and Bioenergy, 2011. **35**(9): p. 3763-3774.
47. Dal-Mas, M., et al., *Strategic design and investment capacity planning of the ethanol supply chain under price uncertainty*. Biomass and Bioenergy, 2011. **35**(5): p. 2059-2071.

48. Gebreslassie, B.H., Y. Yao, and F. You, *Design Under Uncertainty of Hydrocarbon Biorefinery Supply Chains: Multiobjective Stochastic Programming Models, Decomposition Algorithm, and a Comparison Between CVaR and Downside Risk*. *AIChE Journal*, 2012. **58**(7): p. 24.
49. Marvin, W.A., L.D. Schmidt, and P. Daoutidis, *Biorefinery Location and Technology Selection Through Supply Chain Optimization*. *Industrial & Engineering Chemistry Research*, 2012. **52**(9): p. 3192-3208.
50. Floudas, C.A., J.A. Elia, and R.C. Baliban, *Hybrid and single feedstock energy processes for liquid transportation fuels: A critical review*. *Computers & Chemical Engineering*, 2012. **41**: p. 24-51.
51. Grossmann, I., *Enterprise-wide optimization: A new frontier in process systems engineering*. *AIChE Journal*, 2005. **51**(7): p. 1846-1857.
52. Grossmann, I.E. and A.W. Westerberg, *Research challenges in process systems engineering*. *AIChE Journal*, 2000. **46**(9): p. 1700-1703.
53. Bakshi, B.R. and J. Fiksel, *The quest for sustainability: Challenges for process systems engineering*. *AIChE Journal*, 2003. **49**(6): p. 1350-1358.
54. Aden, A., et al., *Lignocellulosic Biomass to Ethanol Process Design and Economics Utilizing Co-Current Dilute Acid Prehydrolysis and Enzymatic Hydrolysis for Corn Stover*. 2002, National Renewable Energy Laboratory: Golden, Colorado, USA.
55. Humbird, D., et al., *Process design and economics for biochemical conversion of lignocellulosic biomass to ethanol*. *Contract*, 2011. **303**: p. 275-3000.
56. Kazi, F.K., et al., *Techno-economic comparison of process technologies for biochemical ethanol production from corn stover*. *Fuel*, 2010. **89**(SUPPL. 1): p. S20-S28.
57. Wright, M.M., et al., *Techno-economic analysis of biomass fast pyrolysis to transportation fuels*. *Fuel*, 2010. **89**, **Supplement 1**(0): p. S2-S10.
58. Zhang, Y., et al., *Techno-economic analysis of two bio-oil upgrading pathways*. *Chemical Engineering Journal*, 2013. **225**(0): p. 895-904.
59. Gnansounou, E. and A. Dauriat, *Techno-economic analysis of lignocellulosic ethanol: A review*. *Bioresource Technology*, 2010. **101**(13): p. 4980-4991.
60. Galbe, M., et al., *Process Engineering Economics of Bioethanol Production*, in *Biofuels*, L. Olsson, Editor. 2007, Springer Berlin Heidelberg. p. 303-327.
61. Swanson, R.M., et al., *Techno-economic analysis of biomass-to-liquids production based on gasification*. *Fuel*, 2010. **89**, **Supplement 1**(0): p. S11-S19.
62. Anex, R.P., et al., *Techno-economic comparison of biomass-to-transportation fuels via pyrolysis, gasification, and biochemical pathways*. *Fuel*, 2010. **89**, **Supplement 1**(0): p. S29-S35.
63. Seabra, J.E.A., et al., *A techno-economic evaluation of the effects of centralized cellulosic ethanol and co-products refinery options with sugarcane mill clustering*. *Biomass and Bioenergy*, 2010. **34**(8): p. 1065-1078.

64. Tittmann, P.W., et al., *A spatially explicit techno-economic model of bioenergy and biofuels production in California*. Journal of Transport Geography, 2010. **18**(6): p. 715-728.
65. Tong, K., F. You, and G. Rong, *Robust design and operations of hydrocarbon biofuel supply chain integrating with existing petroleum refineries considering unit cost objective*. Computers & Chemical Engineering, 2014. **68**(0): p. 128-139.
66. Tong, K., et al., *Optimal design of advanced drop-in hydrocarbon biofuel supply chain integrating with existing petroleum refineries under uncertainty*. Biomass and Bioenergy, 2014. **60**(0): p. 108-120.
67. Gabriel, K. and M. El-Halwagi, *Modeling and optimization of a bioethanol production facility*. Clean Technologies and Environmental Policy, 2013. **15**(6): p. 931-944.
68. Sharma, P., B. Sarker, and J.A. Romagnoli, *A decision support tool for strategic planning of sustainable biorefineries*. Computers & Chemical Engineering, 2011. **35**(9): p. 1767-1781.
69. Sharma, P., R. Vlosky, and J.A. Romagnoli, *Strategic value optimization and analysis of multi-product biomass refineries with multiple stakeholder considerations*. Computers & Chemical Engineering, 2013. **50**(0): p. 105-129.
70. Geraili, A., P. Sharma, and J.A. Romagnoli, *A modeling framework for design of nonlinear renewable energy systems through integrated simulation modeling and metaheuristic optimization: Applications to biorefineries*. Computers and Chemical Engineering, 2014. **61**: p. 102-117.
71. Mansoornejad, B., E.N. Pistikopoulos, and P.R. Stuart, *Scenario-based strategic supply chain design and analysis for the forest biorefinery using an operational supply chain model*. International Journal of Production Economics, 2013. **144**(2): p. 618-634.
72. Ekşioğlu, S.D., et al., *Analyzing the design and management of biomass-to-biorefinery supply chain*. Computers & Industrial Engineering, 2009. **57**(4): p. 1342-1352.
73. Balaman, Ş.Y. and H. Selim, *A network design model for biomass to energy supply chains with anaerobic digestion systems*. Applied Energy, 2014. **130**(0): p. 289-304.
74. Sammons, N., et al., *A flexible framework for optimal biorefinery product allocation*. Environmental Progress, 2007. **26**(4): p. 349-354.
75. Kim, J., S.M. Sen, and C.T. Maravelias, *An optimization-based assessment framework for biomass-to-fuel conversion strategies*. Energy & Environmental Science, 2013. **6**(4): p. 1093-1104.
76. Pham, V. and M. El-Halwagi, *Process synthesis and optimization of biorefinery configurations*. AIChE Journal, 2012. **58**(4): p. 1212-1221.
77. Zondervan, E., et al., *Optimal design of a multi-product biorefinery system*. Computers & Chemical Engineering, 2011. **35**(9): p. 1752-1766.
78. Baliban, R.C., J.A. Elia, and C.A. Floudas, *Biomass and Natural Gas to Liquid Transportation Fuels: Process Synthesis, Global Optimization, and*

- Topology Analysis*. Industrial & Engineering Chemistry Research, 2013. **52**(9): p. 3381-3406.
79. Baliban, R.C., J.A. Elia, and C.A. Floudas, *Biomass to liquid transportation fuels (BTL) systems: process synthesis and global optimization framework*. Energy & Environmental Science, 2013. **6**(1): p. 267-287.
  80. Baliban, R.C., J.A. Elia, and C.A. Floudas, *Optimization framework for the simultaneous process synthesis, heat and power integration of a thermochemical hybrid biomass, coal, and natural gas facility*. Computers & Chemical Engineering, 2011. **35**(9): p. 1647-1690.
  81. Wang, B., B.H. Gebreslassie, and F. You, *Sustainable design and synthesis of hydrocarbon biorefinery via gasification pathway: Integrated life cycle assessment and techno-economic analysis with multiobjective superstructure optimization*. Computers & Chemical Engineering, 2013. **52**(0): p. 55-76.
  82. You, F., et al., *Optimal design of sustainable cellulosic biofuel supply chains: Multiobjective optimization coupled with life cycle assessment and input-output analysis*. AIChE Journal, 2012. **58**(4): p. 1157-1180.
  83. Santibañez-Aguilar, J.E., et al., *Optimal planning and site selection for distributed multiproduct biorefineries involving economic, environmental and social objectives*. Journal of Cleaner Production, 2014. **65**(0): p. 270-294.
  84. Lira-Barragán, L.F., et al., *Optimal design of process energy systems integrating sustainable considerations*. Energy, 2014(0).
  85. Giarola, S., F. Bezzo, and N. Shah, *A risk management approach to the economic and environmental strategic design of ethanol supply chains*. Biomass and Bioenergy, 2013. **58**(0): p. 31-51.
  86. Morales-Rodriguez, R., et al., *A framework for model-based optimization of bioprocesses under uncertainty: Lignocellulosic ethanol production case*. Computers & Chemical Engineering, 2012. **42**(0): p. 115-129.
  87. Sharma, B., et al., *Scenario optimization modeling approach for design and management of biomass-to-biorefinery supply chain system*. Bioresource Technology, 2013. **150**(0): p. 163-171.
  88. Geraili, A., P. Sharma, and J.A. Romagnoli, *Technology analysis of integrated biorefineries through process simulation and hybrid optimization*. Energy, 2014(0).
  89. Amundson, J.S., *Modeling of Biorefinery Supply Chain Economic Performance with Discrete Event Simulation*, in *Manufacturing Systems Engineering*. 2013, University of Kentucky: Lexington, KY, USA.
  90. Sukumara, S., et al., *Multidisciplinary Approach in Developing Region Specific Optimization Tool for Sustainable Biorefining*. 22nd European Symposium on Computer Aided Process Engineering, 2012. **30**: p. 157-161.
  91. Young, D., R. Scharp, and H. Cabezas, *The waste reduction (WAR) algorithm: environmental impacts, energy consumption, and engineering economics*. Waste Management, 2000. **20**(8): p. 605-615.



92. Bare, J., *TRACI 2.0: the tool for the reduction and assessment of chemical and other environmental impacts 2.0*. Clean Technologies and Environmental Policy, 2011. **13**(5): p. 687-696.
93. Goldberg, M., *Jobs and Economic Development Impact (JEDI) Model*. 2009, National Renewable Energy Laboratory: Golden, Colorado, US.
94. Demirbas, A., *Political, economic and environmental impacts of biofuels: A review*. Applied Energy, 2009. **86**, **Supplement 1**(0): p. S108-S117.
95. Gan, J. and C.T. Smith, *Optimal plant size and feedstock supply radius: A modeling approach to minimize bioenergy production costs*. Biomass and Bioenergy, 2011. **35**(8): p. 3350-3359.
96. McKendry, P., *Energy production from biomass (part 2): conversion technologies*. Bioresource Technology, 2002. **83**(1): p. 47-54.
97. Association, R.F. *Monthly U.S. Fuel Ethanol Production/Demand*. 2014 [cited 2014 July 30]; Available from: <http://ethanolrfa.org/pages/monthly-fuel-ethanol-production-demand>.
98. Bohlmann, G.M., *Process economic considerations for production of ethanol from biomass feedstocks*. Industrial Biotechnology, 2006. **2**(1): p. 14-20.
99. Coyle, W.T., *USDA Economic Research Service-Next-Generation Biofuels: Near-Term Challenges and Implications for Agriculture*. 2013.
100. Downing, M., et al., *U.S. Billion-Ton Update: Biomass Supply for a Bioenergy and Bioproducts Industry*. 2011. p. Medium: ED.
101. Perlack, R.D., et al., *Biomass as feedstock for a bioenergy and bioproducts industry: the technical feasibility of a billion-ton annual supply*. 2005, DTIC Document.
102. Tripp, S., R. Powell, and P. Nelson, *Regional Strategy for Biobased Products in Mississippi delta*. 2009, Battelle Technology Partnership Practice, BioDimensions, Inc.: Memphis, Tennessee, USA.
103. Lynd, L., et al., *Strategic biorefinery analysis: analysis of biorefineries*, in *National Renewable Energy Laboratory, Golden, CO, Technical Report No. NREL/SR-510-35578*. 2005.
104. Lior, N., *Energy resources and use: The present (2008) situation and possible sustainable paths to the future*. Energy, 2010. **35**(6): p. 2631-2638.
105. NETL. *Gasification Plant Databases*. 2014 [cited 2014 07 August]; United States Proposed Gasification Plant Databases]. Available from: <http://www.netl.doe.gov/research/coal/energy-systems/gasification/gasification-plant-databases>.
106. Basu, P., J. Butler, and M.A. Leon, *Biomass co-firing options on the emission reduction and electricity generation costs in coal-fired power plants*. Renewable Energy, 2011. **36**(1): p. 282-288.
107. García, A., M. González Alriols, and J. Labidi, *Evaluation of different lignocellulosic raw materials as potential alternative feedstocks in biorefinery processes*. Industrial Crops and Products, 2014. **53**(0): p. 102-110.
108. Technology, A. p. Aspen Plus.

109. Abelha, P., et al., *Combustion of poultry litter in a fluidised bed combustor* ☆. Fuel, 2003. **82**(6): p. 687-692.
110. Miles, T.R., et al., *Alkali deposits found in biomass powerplants: A preliminary investigation of their extent and nature*. 1995, NREL: Golden, CO.
111. Demirbaş, A., *Sustainable cofiring of biomass with coal*. Energy Conversion and Management, 2003. **44**(9): p. 1465-1479.
112. Kirkels, A.F. and G.P.J. Verbong, *Biomass gasification: Still promising? A 30-year global overview*. Renewable and Sustainable Energy Reviews, 2011. **15**(1): p. 471-481.
113. Ho, D.P., H.H. Ngo, and W. Guo, *A mini review on renewable sources for biofuel*. Bioresource Technology, 2014(0).
114. Kenney, K.L., et al., *Understanding biomass feedstock variability*. Biofuels, 2012. **4**(1): p. 111-127.
115. Zevenhoven-Onderwater, M., et al., *The ash chemistry in fluidised bed gasification of biomass fuels. Part I: predicting the chemistry of melting ashes and ash-bed material interaction*. Fuel, 2001. **80**(10): p. 1489-1502.
116. Franco, C., et al., *The study of reactions influencing the biomass steam gasification process* ☆. Fuel, 2003. **82**(7): p. 835-842.
117. Kumar, A., D. Jones, and M. Hanna, *Thermochemical Biomass Gasification: A Review of the Current Status of the Technology*. Energies, 2009. **2**(3): p. 556-581.
118. Ptasiński, K.J., M.J. Prins, and A. Pierik, *Exergetic evaluation of biomass gasification*. Energy, 2007. **32**(4): p. 568-574.
119. Sutton, D., B. Kelleher, and J.R.H. Ross, *Review of literature on catalysts for biomass gasification*. Fuel Processing Technology, 2001. **73**(3): p. 155-173.
120. Ni, Q. and A. Williams, *A simulation study on the performance of an entrained-flow coal gasifier*. Fuel, 1995. **74**(1): p. 102-110.
121. AspenPlus, *Moving Bed Coal Gasifier*. 2010. p. Aspen Plus Simulation for Moving Bed Coal Gasifier.
122. AspenPlus, *Model for Entrained Flow Coal Gasifier*. 2010. p. Aspen Plus Simulation of Entrained Flow Coal Gasifier.
123. AspenPlus, *Aspen Plus IGCC Model*. 2010.
124. McKendry, P., *Energy production from biomass (part 3): gasification technologies*. Bioresource Technology, 2002. **83**(1): p. 55-63.
125. Hepola, J. and P. Simell, *Sulphur poisoning of nickel-based hot gas cleaning catalysts in synthetic gasification gas: I. Effect of different process parameters*. Applied Catalysis B: Environmental, 1997. **14**(3-4): p. 287-303.
126. Burr, B. and L. Lyddon. *A comparison of physical solvents for acid gas removal*. in *GPA Annual Convention Proceedings*. 2008.
127. Sun, L. and R. Smith, *Rectisol wash process simulation and analysis*. Journal of Cleaner Production, 2013. **39**: p. 321-328.

128. Zare, A.H. and S. Mirzaei, *Removal of CO<sub>2</sub> and H<sub>2</sub>S using aqueous alkanolamine solutions*. World Academy of Science, Engineering and Technology, 2009. **37**: p. 194-203.
129. Hamelinck, C.N. and A.P.C. Faaij, *Future prospects for production of methanol and hydrogen from biomass*. Journal of Power Sources, 2002. **111**(1): p. 1-22.
130. Choi, Y. and H.G. Stenger, *Water gas shift reaction kinetics and reactor modeling for fuel cell grade hydrogen*. Journal of Power Sources, 2003. **124**(2): p. 432-439.
131. Davis, B.H., *Fischer-Tropsch synthesis: relationship between iron catalyst composition and process variables*. Catalysis Today, 2003. **84**(1-2): p. 83-98.
132. Espinoza, R.L., et al., *Low temperature Fischer-Tropsch synthesis from a Sasol perspective*. Applied Catalysis A: General, 1999. **186**(1-2): p. 13-26.
133. Dry, M.E., *The Fischer-Tropsch process: 1950-2000*. Catalysis Today, 2002. **71**(3-4): p. 227-241.
134. Zimmerman, W.H. and D.B. Bukur, *Reaction kinetics over iron catalysts used for the fischer-tropsch synthesis*. The Canadian Journal of Chemical Engineering, 1990. **68**(2): p. 292-301.
135. de Deugd, R., F. Kapteijn, and J. Moulijn, *Trends in Fischer-Tropsch Reactor Technology—Opportunities for Structured Reactors*. Topics in Catalysis, 2003. **26**(1-4): p. 29-39.
136. EIA, *Refiners'/Gas Plant Operators' Monthly Petroleum Product Sales Report*. 2012, Energy Information Administration: Washington DC, USA.
137. DOE. *US Billion-Ton Update*. 2011 [cited 2014 04 August]; Available from: [http://www1.eere.energy.gov/bioenergy/pdfs/btu\\_crop\\_residues.pdf](http://www1.eere.energy.gov/bioenergy/pdfs/btu_crop_residues.pdf).
138. Luo, L., E. van der Voet, and G. Huppes, *An energy analysis of ethanol from cellulosic feedstock—Corn stover*. Renewable and Sustainable Energy Reviews, 2009. **13**(8): p. 2003-2011.
139. Vassilev, S.V., et al., *An overview of the chemical composition of biomass*. Fuel, 2010. **89**(5): p. 913-933.
140. Plus, A. *Estimating Physical Properties for a Non-Databank Component*. Building and Running a Process Model  
1998 [cited 2014 04 August]; Available from: <http://www.chemengr.ucsb.edu/~ceweb/courses/che184b/ Aspenplus/GettingStartedBuildingandRunning.pdf>.
141. Schell, D. and C. Harwood, *Milling of lignocellulosic biomass*. Applied Biochemistry and Biotechnology, 1994. **45-46**(1): p. 159-168.
142. Alvira, P., et al., *Pretreatment technologies for an efficient bioethanol production process based on enzymatic hydrolysis: A review*. Bioresource Technology, 2010. **101**(13): p. 4851-4861.
143. Kumar, P., et al., *Methods for Pretreatment of Lignocellulosic Biomass for Efficient Hydrolysis and Biofuel Production*. Industrial & Engineering Chemistry Research, 2009. **48**(8): p. 3713-3729.

144. Mosier, N., et al., *Features of promising technologies for pretreatment of lignocellulosic biomass*. *Bioresource Technology*, 2005. **96**(6): p. 673-686.
145. Chovau, S., et al., *Influence of fermentation by-products on the purification of ethanol from water using pervaporation*. *Bioresource Technology*, 2011. **102**(2): p. 1669-1674.
146. Ezeji, T.C., N. Qureshi, and H.P. Blaschek, *Acetone butanol ethanol (ABE) production from concentrated substrate: reduction in substrate inhibition by fed-batch technique and product inhibition by gas stripping*. *Applied Microbiology and Biotechnology*, 2004. **63**(6): p. 653-658.
147. Simo, M., C.J. Brown, and V. Hlavacek, *Simulation of pressure swing adsorption in fuel ethanol production process*. *Computers & Chemical Engineering*, 2008. **32**(7): p. 1635-1649.
148. Vane, L.M., *A review of pervaporation for product recovery from biomass fermentation processes*. *Journal of Chemical Technology & Biotechnology*, 2005. **80**(6): p. 603-629.
149. Carriquiry, M., X. Du, and G. Timilsina, *Production Costs of Biofuels*, in *The Impacts of Biofuels on the Economy, Environment, and Poverty*, G.R. Timilsina and D. Zilberman, Editors. 2014, Springer New York. p. 33-46.
150. Duran, M.A. and I.E. Grossmann, *Simultaneous optimization and heat integration of chemical processes*. *AIChE Journal*, 1986. **32**(1): p. 123-138.
151. Foust, T., et al., *An economic and environmental comparison of a biochemical and a thermochemical lignocellulosic ethanol conversion processes*. *Cellulose*, 2009. **16**(4): p. 547-565.
152. Tako, A.A. and S. Robinson, *The application of discrete event simulation and system dynamics in the logistics and supply chain context*. *Decision Support Systems*, 2012. **52**(4): p. 802-815.
153. Milbrandt, *A Geographic Perspective on the Current Biomass Resource Availability in the United States*. 2005, National Renewable Energy Laboratory: Golden, Colorado, USA. p. 13,19.
154. GoogleMaps, *Google Maps*. 2013, Google.
155. EIA. *Biofuels Issues and Trends*. 2014 [cited 2014 12 August]; Available from: <http://www.eia.gov/biofuels/issuestrends/>.
156. Qureshi, N., et al., *Process integration for simultaneous saccharification, fermentation, and recovery (SSF): Production of butanol from corn stover using Clostridium beijerinckii P260*. *Bioresource Technology*, 2014. **154**(0): p. 222-228.
157. Swana, J., et al., *An analysis of net energy production and feedstock availability for biobutanol and bioethanol*. *Bioresource Technology*, 2011. **102**(2): p. 2112-2117.
158. Pfromm, P.H., et al., *Bio-butanol vs. bio-ethanol: A technical and economic assessment for corn and switchgrass fermented by yeast or Clostridium acetobutylicum*. *Biomass and Bioenergy*, 2010. **34**(4): p. 515-524.
159. Zhang, Y. and T. Ezeji, *Elucidating and alleviating impacts of lignocellulose-derived microbial inhibitors on Clostridium beijerinckii during fermentation*

- of Miscanthus giganteus to butanol*. Journal of Industrial Microbiology & Biotechnology, 2014: p. 1-12.
160. Batidzirai, B., E.W. Smeets, and A.C. Faaij, *New Conversion Technologies for Liquid Biofuels Production in Africa*, in *Bioenergy for Sustainable Development in Africa*, R. Janssen and D. Rutz, Editors. 2012, Springer Netherlands. p. 117-130.
  161. Clark, J.H., et al., *Green chemistry and the biorefinery: a partnership for a sustainable future*. Green Chemistry, 2006. **8**(10): p. 853-860.
  162. DOE. *Integrated Biorefineries: Biofuels, Biopower and Bioproducts*. Energy Efficiency and Renewable Energy 2010 [cited 2013 May]; DOE/EE-0379]. Available from: [http://www1.eere.energy.gov/biomass/pdfs/ibr\\_portfolio\\_overview.pdf](http://www1.eere.energy.gov/biomass/pdfs/ibr_portfolio_overview.pdf).
  163. Gebreslassie, B.H., Y. Yao, and F. You, *Design under uncertainty of hydrocarbon biorefinery supply chains: Multiobjective stochastic programming models, decomposition algorithm, and a Comparison between CVaR and downside risk*. AIChE Journal, 2012. **58**(7): p. 2155-2179.
  164. Tang, M., et al., *Systematic approach for conceptual design of an integrated biorefinery with uncertainties*. Clean Technologies and Environmental Policy, 2013. **15**(5): p. 783-799.
  165. Rajagopal, D. and D. Zilberman, *Environmental, economic and policy aspects of biofuels*. Foundations and Trends in Microeconomics, 2008. **4**(5): p. 353-468.
  166. NREL, *NREL's BioFuels Atlas*. 2012.
  167. Esri. *USA Population Density*. 2013; Population density in the United States in 2012.]. Available from: <http://www.arcgis.com/home/webmap/viewer.html?webmap=a18f489521ba4a589762628893be0c13>.
  168. Faulkner, W., et al., *Coupled Optimization and Simulation for Multi-Biomass Source-to-Biorefinery Supply Chain Modeling and Analysis*, in *AIChE Annual Meeting*. 2011: Minneapolis, MN.
  169. Amundson, J., et al., *A Bayesian Network Based Approach for Risk Modeling to Aid in Development of Sustainable Biomass Supply Chains*. 22nd European Symposium on Computer Aided Process Engineering, 2012. **30**: p. 152-156.
  170. Jenkins, B.M., et al., *Combustion properties of biomass*. Fuel Processing Technology, 1998. **54**(1-3): p. 17-46.
  171. Worley, M. and J. Yale, *Biomass Gasification Technology Assessment*. 2012, Harris Group inc, National Renewable Energy Laboratory: Atlanta, Georgia, USA.
  172. Energy Information Administration, U.S. *Petroleum & other liquids prices*. 2011; Available from: <http://www.eia.gov/petroleum/data.cfm#prices>.
  173. Font-Palma, C., *Characterisation, kinetics and modelling of gasification of poultry manure and litter: An overview*. Energy Conversion and Management, 2012. **53**(1): p. 92-98.

174. Sims, R.E.H., et al., *An overview of second generation biofuel technologies*. Bioresource Technology, 2010. **101**(6): p. 1570-1580.
175. DOE, *Bioenergy Knowledge Discovery Framework*. 2013, U.S Department of Energy.
176. Laser, M., et al., *Projected mature technology scenarios for conversion of cellulosic biomass to ethanol with coproduction thermochemical fuels, power, and/or animal feed protein*. Biofuels, Bioproducts and Biorefining, 2009. **3**(2): p. 231-246.
177. Dunnett, A., C. Adjiman, and N. Shah, *A spatially explicit whole-system model of the lignocellulosic bioethanol supply chain: an assessment of decentralised processing potential*. Biotechnology for Biofuels, 2008. **1**(1): p. 1-17.
178. Bernardi, A., S. Giarola, and F. Bezzo, *Spatially Explicit Multiobjective Optimization for the Strategic Design of First and Second Generation Biorefineries Including Carbon and Water Footprints*. Industrial & Engineering Chemistry Research, 2013. **52**(22): p. 7170-7180.
179. Bernardi, A., S. Giarola, and F. Bezzo, *Optimizing the economics and the carbon and water footprints of bioethanol supply chains*. Biofuels, Bioproducts and Biorefining, 2012. **6**(6): p. 656-672.
180. Sukumara, S. and J.R. Seay, *A novel model for evaluating the viability of strategies for biorefining processes from various stakeholder perspectives: Case study on marginal land utilization*, in *Computer Aided Chemical Engineering*. 2014. p. 627-632.
181. Dale, V.H., et al., *Biofuels: implications for land use and biodiversity*. 2010: Ecological Society of America Washington, DC.
182. Post, W.M., et al., *Marginal Lands: Concept, Assessment and Management*. Journal of Agricultural Science, 2013. **5**(5): p. 129-139.
183. Gelfand, I., et al., *Sustainable bioenergy production from marginal lands in the US Midwest*. Nature, 2013. **493**(7433): p. 514-517.
184. Butterbach-Bahl, K. and R. Kiese, *Bioenergy: Biofuel production on the margins*. Nature, 2013. **493**(7433): p. 483-485.
185. kang, S., et al., *Marginal Lands: Concept, Assessment and Management*. 2013. Vol. 5. 2013.
186. Milbrandt, A. and R.P. Overend, *Assessment of Biomass Resources from Marginal Lands in APEC Economies*, in *Related Information: Posted with Permission. Prepared for the APEC Energy Working Group under EWG 11/2008A*. 2009. p. Medium: ED; Size: 52 pp.
187. Kerckhoffs, H. and R. Renquist, *Biofuel from plant biomass*. Agronomy for Sustainable Development, 2013. **33**(1): p. 1-19.
188. Debolt, S., et al., *Life cycle assessment of native plants and marginal lands for bioenergy agriculture in Kentucky as a model for south-eastern USA*. GCB Bioenergy, 2009. **1**(4): p. 308-316.
189. Wright, L., *Historical perspective on how and why switchgrass was selected as a "model" high-potential energy crop*, in *ORNL/TM-2007/109 Oak Ridge*,

*TN: Bioenergy Resources and Engineering Systems*. 2007, Oak Ridge National Laboratory: Oak Ridge, Tennessee, USA.

190. Garland, C.D. *Growing and Harvesting Switchgrass for Ethanol Production in Tennessee*. 2008 [cited 2014 19 August]; Available from: <https://utextension.tennessee.edu/publications/Documents/SP701-A.pdf>.
191. Vogel, K.P., et al., *Switchgrass Biomass Production in the Midwest USA This research was funded in part by the U.S. Dep. of Energy's Biomass Fuels program via Oak Ridge Natl. Lab., USDA-ARS, and the Univ. of Nebraska. Contract no. DE-A105-900R21954. Joint contrib. of the USDA-ARS and the Univ. of Nebraska Agric. Exp. Stn. as Journal Article 13263*. *Agron. J.*, 2002. **94**(3): p. 413-420.
192. Makaju, S.O., et al., *Switchgrass Winter Yield, Year-Round Elemental Concentrations, and Associated Soil Nutrients in a Zero Input Environment*. *Agron. J.*, 2013. **105**(2): p. 463-470.
193. Adler, P.R., et al., *Biomass yield and biofuel quality of switchgrass harvested in fall or spring*. *Agronomy Journal*, 2006. **98**(6): p. 1518-1525.
194. Kadam, K.L., E.C. Rydholm, and J.D. McMillan, *Development and Validation of a Kinetic Model for Enzymatic Saccharification of Lignocellulosic Biomass*. *Biotechnology Progress*, 2004. **20**(3): p. 698-705.

## Vita

### Place of Birth

Parumala, Kerala, India

### Education

*Master of Science*, Chemical Engineering, Texas A&M University, Kingsville, USA

*Bachelor of Technology*, Chemical Engineering, University of Calicut, India

### Honors and Awards

*Honorable Mention Award*, AIChE Sustainable Engineering Forum (SEF), 2014

*Outstanding Graduate Student Award*, Department of Chemical and Material Engineering 2014, Lexington, KY, USA

*Best Student Research Poster*, AIChE Annual Meeting 2013, San Francisco, CA, USA

*Outstanding Graduate Research Award*, 3rd International Congress on Sustainability Science & Engineering 2013, Cincinnati OH, USA

*Outstanding Graduate Student Research Award*, the TFISE - 2nd Annual Research Showcase, 2011, Lexington, KY, USA

*USEC Inc. Graduate Fellowship*, for academic year 2010-2011

### Publications

Sukumara, S., J. Seay, F. Badurdeen, W. Faulkner, J. Amundson (2013), “A *Multidisciplinary Decision Support Tool for Evaluating Multiple Biorefinery Conversion Technologies and Supply Chain Performance*”, Clean Technologies and Environmental Policy. December 2013 ([Link to Manuscript](#))

Sukumara, S., J. Seay, F. Badurdeen, W. Faulkner, J. Amundson (2014), “A *Comprehensive Techno-Economic Analysis Tool to Validate Long-Term Viability of Emerging Biorefining Processes*”, Clean Technologies and Environmental Policy. Under Review.

### Book Chapter

J. Amundson, S. Sukumara, J. Seay and F. Badurdeen (2014), “*Decision Support Models for Integrated Design of Bioenergy Supply Chains*”, Handbook of Bioenergy. Under Review

### Peer Reviewed Conference Proceedings

Sukumara, S. and J.R. Seay (2014), “*A novel model for evaluating the viability of strategies for biorefining processes from various stakeholder perspectives: Case study*”



*on marginal land utilization*”, in Computer Aided Chemical Engineering. p. 627-632. ([Link to Manuscript](#))

Sukumara, S., Amundson, J., W. Faulkner, F. Badurdeen, J. Seay (2012), “*Multidisciplinary Approach in Developing Region Specific Optimization Tool for Integrated Biorefining*”, Computer Aided Chemical Engineering, Vol. 30, pp. 157 – 161. ([Link to Manuscript](#))

Amundson, J., Faulkner, W., Sukumara, S., Seay, JR. and Badurdeen, F, (2012), “*A basian network based approach for risk modeling to aid in development of sustainable biomass supply chains*”, in 22nd European Symposium on Computer Aided Process Engineering, Elsevier: London, UK. ([Link to Manuscript](#))

### **Presentations**

- MACE Spring Symposium, *A Multidisciplinary Techno-Economic Framework for Validating Long-Term Viability of Biorefining Processes*, 2014, Lexington, KY, USA
- AIChE Annual Meeting, *A Framework to Examine and Validate Sustainability of Biorefining Processes*, 2013, San Francisco, CA, USA
- AIChE Annual Meeting, *Feed Flexible Multidisciplinary Process Optimization Model for Region Specific Sustainable Biorefining*, 2012, Pittsburgh, PA, USA
- AIChE Annual Meeting, *Multidisciplinary Approach in Developing Region Specific Model for Sustainable Biorefining*, 2011, Minneapolis, MN, USA
- AIChE Annual Meeting, *Coupled Optimization and Simulation for Multi-Biomass Source-to-Biorefinery Supply Chain Modeling and Analysis* , 2011, Minneapolis, MN, USA
- AIChE Annual Meeting, *Region Specific Economic Modeling for Integrated Biorefining Using Process Simulation and Supply Chain Optimization*, 2010, Salt Lake City, UT, USA

### **Poster Presentations**

- AIChE Annual Meeting, *Process Optimization Models Supporting Multidisciplinary Framework for Sustainable Biorefining*, 2013, San Francisco, CA. **Awarded Best Poster**
- International Congress on Sustainability Science & Engineering (ICOSSE), *A Framework to Examine Sustainability of Various Biorefining Processes*, 2013, Cincinnati, OH. **Awarded Best Poster**
- International Forum on Sustainable Manufacturing, *Process Optimization Models Supporting Multidisciplinary Framework for Sustainable Biorefining*, 2013, Lexington, KY

- AIChE Annual Meeting, *Feed Flexible Multidisciplinary Process Optimization Model for Region Specific Sustainable Biorefining*, 2011, Minneapolis, MN
- European Symposium of Computer Aided Process Engineering (ESCAPE 22), *Multidisciplinary Approach in Developing Region Specific Optimization Tool for Sustainable Biorefining*, 2012, London, UK
- Tracy Farmer Institute of Sustainability and Environment, *Multidisciplinary Approach in Developing Region Specific Optimization Model for Sustainable Biorefining*, 2011, Lexington, KY. **Awarded Best Poster**
- International Congress on Sustainability Science & Engineering (ICOSSE), *Multidisciplinary Approach in Developing Region Specific Models for Sustainable Biorefining*, 2011, Tucson, AZ
- International Forum on Sustainable Manufacturing, *Supply Chain Optimization in Developing Region Specific Models for Integrated Biorefining*, 2010, Lexington, KY