



University of Kentucky  
UKnowledge

---

Theses and Dissertations--Mechanical  
Engineering

Mechanical Engineering

---

2013

## EXPERIMENTAL INVESTIGATION TO INFORM OPTIMAL CONFIGURATIONS FOR DYNAMIC NEAR-FIELD PASSIVE UHF RFID SYSTEMS

Donnie E. Proffitt II  
*University of Kentucky*, donnie.proffitt@gmail.com

[Right click to open a feedback form in a new tab to let us know how this document benefits you.](#)

---

### Recommended Citation

Proffitt, Donnie E. II, "EXPERIMENTAL INVESTIGATION TO INFORM OPTIMAL CONFIGURATIONS FOR DYNAMIC NEAR-FIELD PASSIVE UHF RFID SYSTEMS" (2013). *Theses and Dissertations--Mechanical Engineering*. 29.

[https://uknowledge.uky.edu/me\\_etds/29](https://uknowledge.uky.edu/me_etds/29)

This Master's Thesis is brought to you for free and open access by the Mechanical Engineering at UKnowledge. It has been accepted for inclusion in Theses and Dissertations--Mechanical Engineering by an authorized administrator of UKnowledge. For more information, please contact [UKnowledge@lsv.uky.edu](mailto:UKnowledge@lsv.uky.edu).

## **STUDENT AGREEMENT:**

I represent that my thesis or dissertation and abstract are my original work. Proper attribution has been given to all outside sources. I understand that I am solely responsible for obtaining any needed copyright permissions. I have obtained and attached hereto needed written permission statements(s) from the owner(s) of each third-party copyrighted matter to be included in my work, allowing electronic distribution (if such use is not permitted by the fair use doctrine).

I hereby grant to The University of Kentucky and its agents the non-exclusive license to archive and make accessible my work in whole or in part in all forms of media, now or hereafter known. I agree that the document mentioned above may be made available immediately for worldwide access unless a preapproved embargo applies.

I retain all other ownership rights to the copyright of my work. I also retain the right to use in future works (such as articles or books) all or part of my work. I understand that I am free to register the copyright to my work.

## **REVIEW, APPROVAL AND ACCEPTANCE**

The document mentioned above has been reviewed and accepted by the student's advisor, on behalf of the advisory committee, and by the Director of Graduate Studies (DGS), on behalf of the program; we verify that this is the final, approved version of the student's dissertation including all changes required by the advisory committee. The undersigned agree to abide by the statements above.

Donnie E. Proffitt II, Student

Dr. John Parker, Major Professor

Dr. James McDonough, Director of Graduate Studies

# EXPERIMENTAL INVESTIGATION TO INFORM OPTIMAL CONFIGURATIONS FOR DYNAMIC NEAR-FIELD PASSIVE UHF RFID SYSTEMS

---

THESIS

---

A thesis submitted in partial fulfillment of the  
requirements for the degree of Master of Science in  
Mechanical Engineering in the College of Engineering  
at the University of Kentucky

By

Donnie E. Proffitt

Lexington, Kentucky

Director: Dr. Johné Parker, Associate Professor of Mechanical Engineering

Lexington, Kentucky

2013

Copyright© Donnie E. Proffitt 2013

## ABSTRACT OF THESIS

### EXPERIMENTAL INVESTIGATION TO INFORM OPTIMAL CONFIGURATIONS FOR DYNAMIC NEAR-FIELD PASSIVE UHF RFID SYSTEMS

RFID has been characterized as a “disruptive technology” that has the potential to revolutionize numerous key sectors. A key advantage of passive RFID applications is the ability to wirelessly transmit automatic identification and related information using very little power. This paper presents an experimental investigation to inform the optimal configuration for programming passive ultra-high frequency (UHF) RFID media in dynamic applications. Dynamic programming solutions must be designed around the tag’s functionality, the physical programming configuration and environment. In this investigation, we present a methodology to determine an optimal configuration to maximize the systems programming efficiency for dynamic applications.

#### KEYWORDS:

Radio-frequency identification, passive UHF tags, programming window, optimization, dynamic programming

---

Donnie Proffitt

---

12-05-2013

EXPERIMENTAL INVESTIGATION TO INFORM OPTIMAL  
CONFIGURATIONS FOR DYNAMIC NEAR-FIELD PASSIVE  
UHF RFID SYSTEMS

By

Donnie Proffitt

Johné M Parker, PH. D.

Director of Thesis

James M. McDonough, PH. D

Director of Graduate Studies

---

# Acknowledgements

The following thesis, while an individual work, benefited from the insights and direction of several people. First, my Thesis Chair, Dr. Parker, exemplifies the high quality scholarship to which I aspire. In addition, Dr. Parker provided timely and instructive comments and evaluating at every stage of the thesis process, allowing me to complete the project on schedule. Next, I want to thank the complete Thesis Committee: Dr. Bauderdeen and Dr. Seigler. Each individual provide insights that guided and challenged my thinking, substantially improving the finished product.

I would like to also acknowledge the UK RFID team that was instrumental in collecting the massive amounts of data on the LexSlide1 robot. The long hours each of you spent in the RFID lab is much appreciated.

In addition to the technical and instrumental assistant above, I received equally important assistance from family and friends. My wife, Kim Proffitt, providing on-going support throughout the thesis process, as well as critically timed motivation for completing the project in a timely manner. My father, Donald Proffitt, instilling in me, from an early age, the desire and skills to obtain the Master's. My Mother, Anna Lee Proffitt, providing me with the insight to identify priorities in my life which is important for the high stress moments in my life. Finally, I wish to thank my three wonderful kids, Brayden, Gavin, and Molly, for the great joy they bring me and Jesus Christ for giving his life for me.

# TABLE OF CONTENTS

ACKNOWLEDGEMENTS.....	III
LIST OF FIGURES .....	VIII
LIST OF TABLES.....	XI
<b>1 INTRODUCTION .....</b>	<b>1</b>
1.1 MOTIVATION .....	1
1.2 INSPIRATION .....	1
1.3 PROBLEM STATEMENT & SCOPE .....	1
1.4 THESIS FORMAT .....	2
<b>2 WHAT IS RFID TECHNOLOGY AND WHY IS IT UNIQUE .....</b>	<b>4</b>
2.1 INTRODUCTION TO RFID AND WHY IT IS <i>UNIQUE</i> .....	4
2.1.1 <i>Customer Personalization and the Power of Unique Identification</i> .....	4
2.1.2 <i>Bar Codes and their limitations</i> .....	5
2.1.3 <i>RFID versus Bar Codes</i> .....	6
2.2 CURRENT MARKET .....	8
2.3 THE CHALLENGES WITH THERMAL RFID PRINTING SOLUTIONS .....	10
2.4 THE BENEFITS OF RFID-ENABLED LASER PRINTERS .....	10
2.5 RFID ENABLED MEDIA .....	11
<b>3 RFID SYSTEM INFRASTRUCTURE.....</b>	<b>15</b>
3.1 SIMPLE COMPONENT SYSTEM LAYOUT .....	15
3.2 READER .....	16
3.3 ANTENNA TYPES: READER ANTENNA AND TAG ANTENNA.....	16
3.3.1 <i>Antenna</i> .....	16
3.3.2 <i>Basic Far Field Antenna Types</i> .....	21
3.3.3 <i>Basic Near Field Antenna types</i> .....	21
3.4 ANTENNA AND TAG DESIGN BEST PRACTICES .....	23
3.5 TAGS .....	23
3.6 STANDARDS .....	26
3.6.1 <i>ISO</i> .....	26
3.6.2 <i>INCITS</i> .....	26
3.6.3 <i>ICAO</i> .....	27
3.6.4 <i>NIST</i> .....	27
3.6.5 <i>EPCglobal</i> .....	27
3.6.6 <i>Resources</i> .....	27
<b>4 EXPLANATION OF THE RFID SYSTEM AND COMMUNICATES TYPES .....</b>	<b>29</b>
4.1 RFID INFRASTRUCTURE .....	29
4.2 ELECTRONIC PRODUCT CODE (EPC).....	29
4.2.1 <i>Frequencies</i> .....	30
4.2.2 <i>Communication Types</i> .....	31
4.2.3 <i>Field Regions Types and Boundaries</i> .....	31
4.2.3.1 <i>Reactive Near-Field</i> .....	33
4.2.3.2 <i>Radiating Near-Field</i> .....	34
4.2.3.3 <i>Transition Zone</i> .....	35
4.2.3.4 <i>Far-Field Region</i> .....	35
4.2.3.5 <i>Region Field Summary</i> .....	36

4.3	RADIATING POWER AND FIELD STRENGTH (ERP AND EIRP) .....	37
4.4	RFID UNITS – COMPARING READER POWER OUTPUTS .....	38
4.5	READER OUTPUT POWERS .....	40
4.6	RFID COMMUNICATIONS TYPES .....	40
4.6.1	<i>Inductive Coupling (Near Field)</i> .....	41
4.6.2	<i>Electromagnetic Coupling (Far Field) [64]</i> .....	45
4.6.3	<i>Link Budget and the Friis Equation</i> .....	46
4.7	FORWARD LINK .....	47
4.7.1	<i>Power available at the tag</i> .....	48
4.7.2	<i>Power received or absorbed by the tag</i> .....	48
4.8	POWER ABSORBED BY THE TAG IC .....	50
	Power absorbed by the tag IC .....	50
4.8.1	<i>Factors Limiting Range</i> .....	50
4.8.2	<i>Reverse link</i> .....	51
	<i>Backscattered power</i> .....	52
	<i>Received power of tag signal at the reader</i> .....	52
4.8.3	<i>Link Budgets limiting factors</i> .....	52
<b>5</b>	<b>LEXMARK T654 RFID UHF OPTION .....</b>	<b>53</b>
5.1	SYSTEM PAPER PATH .....	53
5.2	ANTENNA LOCATION WITH RESPECT TO THE PAPER PATH .....	55
5.2.1	<i>Meander Antenna</i> .....	56
5.3	READER – THINGMAGIC 5E .....	57
5.4	PROGRAMMING WINDOWS .....	57
5.5	IDENTIFYING REJECTED RFID LABELS .....	59
5.5.1	<i>Defining the Four RF Regions created around the antenna</i> .....	60
5.6	PREVIOUS RESEARCH .....	62
<b>6</b>	<b>PRINTER PROGRAMMING SIMULATION .....</b>	<b>64</b>
6.1	DESIGN INTENT .....	64
6.2	PROGRAMMING VARIABLES .....	64
6.2.1	<i>Air Gap</i> .....	64
6.2.2	<i>Reader Power Level</i> .....	65
6.2.3	<i>Tag Orientation</i> .....	65
6.2.4	<i>Linear Velocity</i> .....	66
6.3	LEXSLIDE1 TEST FIXTURE .....	66
6.3.1	<i>Infrastructure</i> .....	67
6.3.2	<i>Interchangeable Components</i> .....	68
6.4	SOFTWARE AND THE GRAPHICAL USER INTERFACE (GUI) .....	68
<b>7</b>	<b>TEST SETUP .....</b>	<b>71</b>
7.1	TEST SPECIMENS .....	71
7.1.1	<i>Tags</i> .....	71
7.1.2	<i>Antennas</i> .....	71
7.1.3	<i>Reader</i> .....	72
7.2	TEST TYPES .....	72
7.2.1	<i>Test Type Definitions</i> .....	73
7.2.2	<i>Test Type Definitions</i> .....	73
7.3	TEST PARAMETERS .....	76
7.3.1	<i>Sample Size</i> .....	76
7.3.2	<i>Variables</i> .....	76



7.3.3	<i>Programming Tag input</i> .....	77
7.4	DATA OUTPUT AND THE SECONDARY PROCESS.....	77
7.4.1	<i>Raw Data</i> .....	77
7.4.2	<i>Data Summary</i> .....	78
<b>8</b>	<b>TEST METHODOLOGY</b> .....	<b>80</b>
8.1	TEST REDUCTION STRATEGY .....	81
<b>9</b>	<b>STATISTICAL ANALYSIS</b> .....	<b>82</b>
9.1	PROGRAMMING ENVIRONMENTS.....	82
9.2	REPEATED MEASURED ANOVA (RANOVA).....	82
9.2.1	<i>Data Collection</i> .....	83
9.3	STATISTICAL MODEL: RANDOMIZED COMPLETE BLOCK DESIGN (RCBD).....	83
9.3.1	<i>ANOVA Table for a Randomized Complete Block Design</i> .....	85
9.3.2	<i>The null Hypothesis</i> .....	85
9.4	CALCULATION SOFTWARE .....	87
9.5	OUTPUT DATA TYPES .....	87
9.5.1	<i>Programming Error Radar Plots</i> .....	87
9.5.2	<i>Main Effects and Interaction Pareto Chart</i> .....	88
9.5.3	<i>Offset Testing Plots</i> .....	89
<b>10</b>	<b>TEST ANALYSIS</b> .....	<b>91</b>
10.1.1	<i>No variance between treatments</i> .....	91
10.2	STATIC READ.....	94
10.2.1	<i>Test Parameters</i> .....	94
10.2.2	<i>Statistical Analysis</i> .....	95
10.2.3	<i>Static Read Conclusion</i> .....	103
10.3	STATIC WRITE .....	104
10.3.1	<i>Statistical Analysis</i> .....	105
10.3.2	<i>Static Write Conclusion</i> .....	113
10.3.3	<i>Static Read and Static Write Comparison</i> .....	115
10.3.4	<i>Static read and Static write comparison conclusion</i> .....	120
10.4	STATIC OFFSET .....	121
10.4.1	<i>Test Parameters</i> .....	121
10.4.2	<i>Statistical Analysis</i> .....	122
10.4.3	<i>Static Offset Conclusion</i> .....	131
10.4.4	<i>Recommended Next Steps</i> .....	132
10.5	DYNAMIC.....	133
10.5.1	<i>Test Parameters</i> .....	133
10.5.2	<i>Test Setup</i> .....	134
10.5.3	<i>Data Collection and Linear Velocities</i> .....	135
10.5.4	<i>Statistical Analysis</i> .....	135
10.5.4.1	<i>Dynamic Type I analysis</i> .....	136
10.5.4.2	<i>Dynamic Type II analysis</i> .....	142
10.5.4.3	<i>Dynamic Type III analysis</i> .....	145
10.5.4.4	<i>Dynamic Type IV analysis</i> .....	152
10.5.5	<i>Dynamic Conclusion by analysis type</i> .....	154
10.5.6	<i>Recommended next Steps</i> .....	157
<b>11</b>	<b>CONCLUSION</b> .....	<b>158</b>
11.1	RECOMMENDED PROGRAMMING ENVIRONMENT.....	159

11.2	RECOMMENDED NEXT STEPS TO EXPOUND UPON THIS RESEARCH DATA SET.....	159
11.3	RECOMMENDED NEXT STEPS FOR FURTHER TESTING.....	160
<b>APPENDICES.....</b>		<b>161</b>
A.	THE FIRST RFID PASSIVE SYSTEM.....	162
B.	UHF RFID APPLICATIONS EXAMPLES .....	163
C.	COMPANIES THAT HAVE IMPLEMENTED UHF RFID SYSTEMS .....	165
D.	DOE 2^3 FACTORIAL .....	166
E.	STATIC WRITE DATA.....	167
	<i>Dogbone-Loop</i> .....	167
	<i>Dogbone – Skyetek</i> .....	168
	<i>F. Static Offset Data</i> .....	169
	<i>Dogbone</i> .....	169
	<i>Slim Line</i> .....	169
	<i>Squigg</i> .....	170
	<i>Dogbone – Meander</i> .....	171
G.	GLOSSARY OF TERMS .....	172
<b>REFERENCES.....</b>		<b>188</b>
VITA.....		194

## List of Figures

Figure 1: The Family of Automatic Identification Technologies [14].....	4
Figure 2: Anatomy of a Bar Code.....	5
Figure 3: Barcode vs. RFID - Barcode can identify a product while the RFID tag can uniquely identify a specific object.....	7
Figure 4: Value of passive tags by application in US\$ millions [25] .....	8
Figure 5: Primary inkjet RFID-enable color printer - RX900 [31].....	9
Figure 6: Medical label with 21 2-D bar codes stickers.....	11
Figure 7: Medical wristband with an embedded RFID tag .....	12
Figure 8: Combination label with an embedded RFID tag .....	13
Figure 9: Front and back of RFID enabled combination label.....	13
Figure 10: Combination form with embedded RFID tag for vehicle identification.....	14
Figure 11: Simple component system layout.....	15
Figure 12: Antenna Polarization types [42] .....	18
Figure 13: Radiation Patterns - Antenna Pattern Parameters [43] .....	20
Figure 14: (right) Cross section of a patch antenna and (left) path antenna .....	21
Figure 15: Meander Antenna .....	21
Figure 16: Near Field Antenna Configurations [47].....	22
Figure 17: A transformer loop antenna for a reader [47].....	22
Figure 18: Right: an array of four loop antennas. Left: single loop antenna .....	23
Figure 19: Examples of the different types of commercial passive UHF tags.....	24
Figure 20: Tag construction (left) and antenna type (right) [50] .....	24
Figure 21: (a) typical configuration, (b) arc configuration and (c) dual body configuration [51] .....	24
Figure 22: The parameters of optimal tag design .....	25
Figure 23: Mobility - RFID conveyor belt application [53] .....	29
Figure 24: 96-bit EPC [54] .....	30
Figure 25: RFID regions (Near field, far field and transition zone) [56].....	32
Figure 26: Antenna Field Regions [57].....	32
Figure 27: Two RFID resonators built into a single UHF RFID tag antenna [58] .....	33
Figure 28: Radian Sphere, which represents the reactive near field .....	34
Figure 29: The four RF regions around an antenna .....	36
Figure 30: Surface created by antenna [63] .....	37
Figure 31: Passive Tag Load Modulation [64] .....	41
Figure 32: Calculation of the magnetic field B at location P due to current I on the loop [68]....	42
Figure 33: Decaying of the magnetic field B vs. Distance r .....	43
Figure 34: Magnetic Coupling between antenna and tag [67] .....	43
Figure 35: A single layer coil [68].....	45
Figure 36: Passive tag backscatter modulation [64] .....	46
Figure 37: Link Budget between antenna and tag.....	46
Figure 38: Radio link budget symbols, definitions, units, and descriptions .....	47
Figure 39: Lexmark T654x laser printer and option.....	53
Figure 40: System paper path layout.....	55
Figure 41: RFID Input Option - Houses RFID hardware components .....	55
Figure 42: Top view of the Meander Antenna (yellow line) location with respect to the paper path (red line).....	56
Figure 43: Meander Antenna: A far field antenna that is designed to operate in near field ranged .....	56
Figure 44: ThingMagic 5e Reader [87].....	57
Figure 45: Printer cross section - simple paper path.....	58
Figure 46: Programming window .....	58

Figure 47: Rejected Label Symbol [88].....	59
Figure 48: Radian sphere created around the near field antenna .....	60
Figure 49: The four RF regions centered around the antenna.....	62
Figure 50: Typical Polar Plots of Read-Error Rates Significance at Different Orientations (UPM Raflatac Dogbone, Loop System) [89] .....	63
Figure 51: Large air gap (left) and small air gap (right) .....	65
Figure 52: Tag in 0° orientation with respect to the antenna.....	66
Figure 53: LexSlide1 Main Components .....	67
Figure 55: GUI - Antenna on / off control.....	68
Figure 54: LexSlide1 test fixture .....	68
Figure 56: GUI - Reader power level control .....	69
Figure 57: LexSlide1 graphical user interface (GUI) .....	70
Figure 58: Skyetek m9 Reader.....	72
Figure 59: Successful Write = read + write + verify (read).....	73
Figure 60: Test Types - each test builds the foundation for the following test.....	73
Figure 61: Static test set up: IC of tag is aligned with center of antenna.....	74
Figure 62: Lexslide1 static offset direction.....	74
Figure 63: Static Offset - Tag to antenna orientation and alignment.....	75
Figure 64: Static Offset test at the “0” or “no offset” position. Top view (left) and side view (right) .....	75
Figure 65: Static Offset Test - tag offset from antenna in positive direction.....	75
Figure 66: Lexslide1 static offset direction.....	76
Figure 67: Sample of raw data in Microsoft Excel .....	77
Figure 68: Sample output data and summary.....	78
Figure 69: Sample data summary - raw data converted to a usable format .....	79
Figure 70: Test Matrix - test reduction strategy.....	81
Figure 71: Statistical Analysis types: Repeatability and ANOVA .....	82
Figure 72: 2 <sup>3</sup> factorial Design Test.....	87
Figure 73: Example Programming Error Radar Plot .....	88
Figure 74: Example main effects and interaction Pareto Chart .....	88
Figure 75: Example data - 3 tag types and 2 air gaps .....	89
Figure 76: Example offset testing plot for 90° and 180° tag angles .....	90
Figure 77: Test strategy .....	91
Figure 78: Dogbone Pareto charts and radar plots for all three programming environments.....	98
Figure 79: Dogbone Main Effects and Interaction Plots for all three programming environments .....	99
Figure 80: Slim Line Pareto charts and radar plots for all three programming environments.....	100
Figure 81: Slim Line Main Effects and Interaction plots for all three programming environments .....	101
Figure 82 : Static Read Dogbone Programming Error Radar Plots .....	102
Figure 83: Static Read Slim Line Programming Error Radar Plots .....	102
Figure 84: Static Read main effects for all tests conducted (includes both tag types).....	103
Figure 85: Static Read interaction plot for all tests conducted (includes both tag types) .....	103
Figure 86: Paper Clip Pareto charts and radar plots for the programming environment .....	108
Figure 87: Paper Clip Main Effects and Interaction plots for the programming environment ....	108
Figure 88: Dogbone Pareto charts and radar plots for all three programming environments.....	109
Figure 89: Dogbone Effects and Interaction plots for all three programming environments .....	110
Figure 90: Slim Line Pareto charts and radar plots for all three programming environments.....	111
Figure 91: Slim Line Effects and Interaction plots for all three programming .....	112
Figure 92: Static Write 5 mm air gap radar plot summary .....	113
Figure 93: Static read and static write DOE results (p-values and calculated F-statistic) .....	116

Figure 94: Static read and write main effects DOE plot .....	117
Figure 95: Static read and write interaction DOE plot.....	117
Figure 96: Static read and write residual plots from the DOE analysis .....	118
Figure 97: Static read and write combine main effects DOE plot .....	119
Figure 98: Static read and write interaction DOE plots .....	120
Figure 99: The four RF regions .....	125
Figure 100: Static offset Dogbone Loop programming environments .....	126
Figure 101: Static Offset Dogbone Skyetek .....	127
Figure 102: Static Offset Dogbone Meander .....	128
Figure 103: Static Offset Dogbone Summary .....	129
Figure 104: Reactive sphere and radiative sphere centered about the Loop antenna .....	130
Figure 105: Transition boundary between the reactive and radiative near field regions .....	130
Figure 106 Test Suite - Dynamic .....	133
Figure 107: Power Level for each antenna type and air gap .....	134
Figure 108: Dynamic testing linear slide home position .....	135
Figure 109: Dynamic Loop statistical analysis with all three air gaps individually .....	136
Figure 110: Dynamic Meander statistical analysis with all three air gaps individually .....	137
Figure 111: Dynamic Dogbone Loop main effects and interaction plots for 5, 25 and 50 mm air gaps .....	139
Figure 112: Dynamic Dogbone Loop Pareto residuals plots for 5, 25 and 50 mm air gaps .....	140
Figure 113: Dynamic Dogbone Meander main effects and interaction plots for 5, 25 and 50 mm air gaps .....	141
Figure 114: Dynamic Dogbone Meander Pareto residuals plots for 5, 25 and 50 mm air gaps .....	142
Figure 115: Dynamic Loop statistical analysis with all three air gaps combined.....	143
Figure 116: Dynamic Loop statistical analysis with all three air gaps combined.....	143
Figure 117: Dynamic Dogbone Meander main effects and interaction plots for 5, 25 and 50 mm air gaps Combined .....	144
Figure 118: Dynamic Dogbone Meander Pareto Chart and Residual plots for 5, 25 and 50 mm air gaps Combined .....	144
Figure 119: Dynamic Dogbone Meander main effects and interaction plots for 5, 25 and 50 mm air gaps Combined .....	145
Figure 120: Dynamic Dogbone Meander Pareto Chart and Residual plots for 5, 25 and 50 mm air gaps Combined .....	145
Figure 121: Dynamic Type III analysis null hypotheses results .....	146
Figure 122: Dynamic type III analysis main effects – Loop antenna .....	147
Figure 123: Dynamic type III analysis main effects – Meander antenna.....	148
Figure 124: Dynamic type III analysis interaction plot - Loop antenna .....	149
Figure 125: Dynamic type III analysis interaction plots - Meander antenna.....	149
Figure 126: Dynamic Type III analysis - Loop Antenna .....	150
Figure 127: Dynamic type III analysis Pareto Chart - Meander antenna.....	150
Figure 128: Dynamic type III analysis Residual plots - Loop antenna.....	151
Figure 129: Dynamic type III analysis Residual Plots - Meander antenna.....	152
Figure 130: Successful program vs. Linear Position (9cm/s) .....	153
Figure 131: Successful program vs. Linear Position (31cm/s) .....	154

## List of Tables

Table 1: Differences between bar codes and RFID tags .....	6
Table 2: RFID-enabled printer quick comparisons.....	9
Table 3: Tag summary with optimal application [52].....	26
Table 4: Electronic Product Code (EPC) Tag Classes [55] .....	30
Table 5: Frequencies, descriptions and ranges.....	31
Table 6: RFID coupling mechanisms and their parameters.....	31
Table 7: Summary of Region Fields .....	36
Table 8: Relationship between dBm and mW .....	39
Table 9: Summary of field regions and their locations .....	61
Table 10: LexSlide1 reader power level conversions between dBm, W and mW .....	65
Table 11: Linear velocity conversions between ppm, ips, cm/s, and mm/s .....	66
Table 12: Summary of tested tags.....	71
Table 13: Summary of tested antennas .....	72
Table 14: Test Matrix (576 possible tests).....	80
Table 15: Examples of programming environments.....	82
Table 16: Randomized Complete Block Design (RCBD): Example test sequence summary for Dogbone tag and Meander antenna type.....	83
Table 17: ANOVA table for a Randomized Complete Block Design (RCBD).....	85
Table 18: rANOVA summary (F-statistic) .....	92
Table 19: rANOVA summary (programming error).....	93
Table 20: Static Read Text Matrix (green) .....	94
Table 21: Static Read Test Parameters .....	94
Table 22: Static Read null hypothesis (p-values).....	95
Table 23: Static Read null hypothesis (F-statistic) .....	95
Table 24: Static Write Text Matrix (green) .....	105
Table 25: Static Write test parameters .....	105
Table 26: Static Read null hypothesis (p-values).....	106
Table 27: Static Write null hypothesis (F-statistic) .....	106
Table 28: Static offset test matrix (full – green) and reduced (orange) .....	121
Table 29: Static offset test parameters .....	122
Table 30: Static Offset null hypothesis (90 degree).....	123
Table 31: Static offset null hypothesis (90 and 270 deg).....	123
Table 32: Static Offset programming window summary .....	129
Table 33: Dynamic Test Matrix (yellow) .....	133
Table 34: Dynamic Test Parameters .....	133
Table 35: Dynamic Linear speed and number of total programming events .....	148

# 1 Introduction

## 1.1 Motivation

RFID has been characterized as a “disruptive technology” because it has the potential to “rattle the walls of the conventional...ultimately reshape[ing] our living experience” [1]. This is possible because RFID’s luster is based on the ability to provide information. Information is becoming the currency of society. Information is what drives everything from global economies to personal day to day living. RFID has the capability to induce a thriving market for such information, resulting in easy data access for analysts to infer business intelligence and create deeper relationships between companies and customers. Because of this, RFID tags are widely held to become ubiquitous in our future.

Many companies are leveraging this type of technology for asset identification, retail item management, access control, vehicle security, banking, inventory control, supply chain efficiency, cost reduction and theft / fraud prevention.

Companies such as The Coca-Cola Company [2], The Pub Restaurant [3], Loves Truck Stop [4], Hanmi Pharmaceutical [5], and the Agricultural Back of China [6] are a few examples. See Appendix “Application Examples” for details how these companies are benefiting from RFID implementation.

## 1.2 Inspiration

The inspiration of this thesis was inspired by the Lexmark T654dn Laser Printer UHF RFID solution. The Lexmark RFID solution simultaneously encodes RFID tags embedded into various types of media while also providing human readable data. RFID laser printing solutions have to be designed around the tag’s functionality. Most passive tag performance deficiencies are due to energy and signal discrepancies from the Reader [7].

Performing RFID operations in a laser printing system is difficult because of the raster imaging processing. Once the print job has been initiated it cannot be paused or stopped. This means that once a single sheet of media has been picked from the input tray it must remain in motion until the print job is complete.

The RFID operations are performed after the media is in motion. The nominal media speed is 35 pages per minute (ppm), which converts to 6.4 inches per sec (ips). The dynamic factor creates a limited time where the tag must be identified, programmed and verified in less than one second. This is called the programming window and it is the main limiting constraint in programming RFID tags in a laser printing system.

## 1.3 Problem Statement & Scope

As mentioned above, the main limiting constraint in programming RFID tags in a laser printer is the limited programming window. The scope of this thesis is to fundamentally understand the programming factors in a UHF dynamic system in which the programming window can be optimized. There has been little research conducted in the area. Throughout the thesis the Lexmark T654n Laser Printer UHF RFID solution will be referenced, but the research is not

limited to this device. The research can be applied to any application that involves programming UHF tags in a dynamic environment.

Several studies have been conducted to characterize RFID systems for readability rates and ranges from an experimental approach [8]. However, most studies cover the system from a manufacturing supply chain standpoint [9] [10] [11]. Others have been conducted in order to investigate limitations of programming on or near various materials and liquids, such as wood, metals, food products, and water [12] [13].

The ultimate desired goal is to provide a procedure that can easily be implemented to optimize dynamic RFID programming systems. This is important because RFID applications are numerous, unique and difficult to optimize. The technology found in the main hardware components are constantly changing and each would benefit from the presented process in order to optimize the performance.

## 1.4 Thesis format

The format of this section is divided into 9 sections. They are as follows:

- Chapter 2 - **Explanation of RFID technology from a high level view.** This chapter discusses why RFID is unique, provides examples of real world applications, the current market and their challenges, and lays out the benefits of a RFID enabled printer.
- Chapter 3 – **RFID system infrastructure.** This chapter discusses the RFID system layout and the components that make up that system. This includes the readers, antennas and tags. This chapter also wraps up with the standards that govern the RFID industry.
- Chapter 4 – **Explanation of the RFID system and communication methods.** This chapter explains the RFID from a system perspective. It includes the Electronic Product Code (EPC), the different frequencies, communication types and field regions. This chapter discusses in detail how each of the communication types work: near field and far field.
- Chapter 5 – **Lexmark T654 RFID option.** This chapter introduces the Lexmark RFID enabled printing and programming system. The discussion includes the system layout, how it works and the challenges.
- Chapter 6 – **Printer Programming Simulation** – This chapter lays out the design intent of the LexSlide1 test fixture, the programming variables, test fixture hardware and functionality.
- Chapter 7 – **Test Setup** – The test specimens, test types, test parameters and data output are discussed in this chapter.
- Chapter 8 – **Test methodology** – The test method designed to reduce the degrees of freedom as the testing progresses is presented in this chapter.
- Chapter 9 -- **Statistical Analysis** – This chapter contains all the test analysis from all 5 test types. Each of the 5 test types are presented with the test setup, test parameters, results, conclusions and next steps.



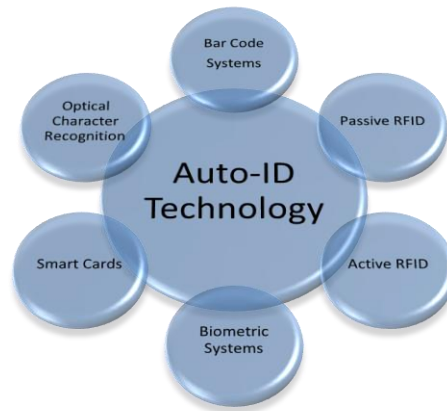
- Chapter 10 – **Conclusion** – the conclusion is a summary of the entire 5 test summaries presented in chapter 9. Additional information has been added about recommended next tests to expound upon the current results

The research thesis wraps up with the references, glossary of terms and appendices.

## 2 What is RFID technology and Why is it Unique

### 2.1 Introduction to RFID and why it is *Unique*

Radio frequency identification (RFID) is a subset of a group of technologies also known as *automatic identification* (or auto-ID), which allows machines to uniquely identify other objects. There is a family of Automatic Identification technologies that includes bar codes and smart cards. Figure 1 includes other technologies types.



**Figure 1: The Family of Automatic Identification Technologies [14]**

#### 2.1.1 Customer Personalization and the Power of Unique Identification

RFID technology will provide unique identification in the form “serial number  $i$  was at location  $l$  at time  $t$ ” [15]. This type of information will be the incentive for markets to push forward where goods are tagged on an individual level. Companies that leverage the power of unique identification will have the potential to experience success in internal, supplier, and customer personalization. There are empirically verified economic benefits for companies to personalize their goods and services [16]. RFID can provide the type of information where these types of relationships can be crafted. RFID is basically a signal sent to the transponder, which wakes up and either reflects back a signal (passive system) or broadcasts a signal (active system). [17]. See appendix B for additional information how passive RFID was first used in WWII.

Data generated through personalization of customer behavior with current products can provide such information. The captured information will allow companies to answer product –related and customer- related questions such as:

- Which products are likely to be bought together?
- What are the characteristics of my customers?
- Does the current service provided match the customer’s behavior?
- Is there a difference between returning and non returning customers?
- Can the customer’s budget be related to their behavior?
- Which additional products should I offer to a customer?

When these types of questions can be answered then there is a high potential to:

- turn casual browsers into buyers,
- match customers to the optimal service or product,
- increase customer loyalty,
- maximize profits by understanding what a specific customer is willing to pay,
- Improve customer relationship management.

### 2.1.2 Bar Codes and their limitations

The bar code has become part of our everyday life. It is estimated by the Uniform Code Council (UCC) that 5 billion bar code are scanned each day world wide [18]. The first transaction with a bar code was on June 26, 1974 in Troy, Ohio on a Juicy Fruit pack of gum [19]. The introduction of the bar code was the culmination of over 30 years of research. The first patent for automatic product coding was developed by two Drexel University graduate students. However, IBM and NCR eventually developed the foundation of the bar coding system that is used around the world today [20].

It has become “the ubiquitous standard for identifying and tracking products” [21]. While the bar code has been institutionalized across most industries and the UCC has become omnipresent there are limitations.

Due to the structure (as shown in Figure 2), a bar code does not have the ability to *uniquely* identify a specific object.



Figure 2: Anatomy of a Bar Code

Take, for example, a bar code on a printer box can tell you the type, size, and producer of the printer. It cannot tell you:

- Where the printer was boxed
- When the printer was produced
- The lot and/or production run during which the printer was made
- Where the printer box traveled in its journey to the shelf

The bar code can only provide the product and its manufacturer. This means that all printers of the same type in a store, on a pallet, distribution center, factory, and throughout the entire supply chain cannot be uniquely identified from each other. The bar code reads the same for all printers of the same type. This means that the bar code cannot provide information to answer the following questions:

- Where was that particular item manufactured?
- In which lot/shift was the item manufactured?

- When was the product manufactured?
- When will the product expire?

### 2.1.3 RFID versus Bar Codes

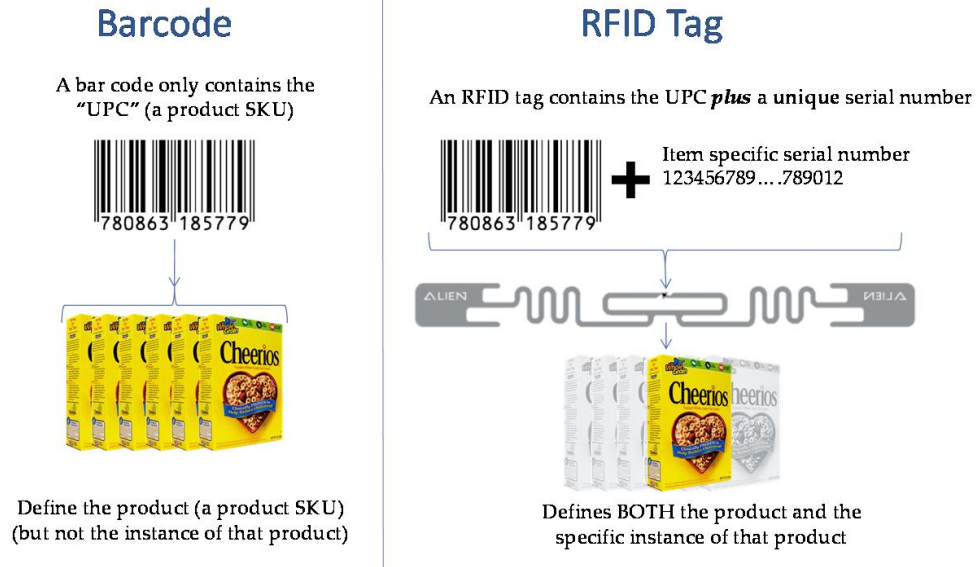
Both bar codes and RFID are indeed similar. They both are auto-ID technologies that are intended to provide rapid and reliable item identification and tracking capabilities. The primary difference is the method in which they identify objects. The bar code requires a reading device that scans a printed label with an optical laser or image technology. However, RFID readers scan, or interrogate, a tag using radio frequency signals. This coined the phrase “radio bar codes”.

Bar codes can only yield information indicating the category of an item. In contrast, an RFID tag can present much more robust serialized information on a specific item, thus identifying it as a unique thing. RFID tags are a “*supercharged*” item identifier, as compared to the bar code [22]. Senator Patrick Leahy described RFID as a bar code “*on steroids*” [23] [24].

**Table 1: Differences between bar codes and RFID tags**

Bar Codes	RFID tags
Bar codes require line of sight to be read	RFID tags can be read or updated without line of sight.
Bar codes can only be read individually	Multiple RFID tags can be read simultaneously.
Bar codes cannot be read if they become dirty or damaged	RFID tags are able to cope with harsh and dirty environments.
Bar codes must be visible to be logged.	RFID tags are ultra thin and can be printed on a label, and they can be read even when concealed within an item
Bar codes can only identify the type of item	RFID tags can identify a specific item.
Bar code information cannot be updated	Electronic information can be overwritten repeatedly on RFID tags.
Bar codes must be manually tracked for item identification, making human error an issue.	RFID tags can be automatically tracked, eliminating human error.
Bar codes can be copied and re-distributed making authenticity and / anti counterfeit an issue.	RFID tags have a chip specific ID value that can be linked to the user programmable ID value. Used together eliminates the possibility of improper duplication.

Figure 3 below clearly shows the limitation of the barcode and the value add of the RFID tag’s ability to uniquely identify objects.



**Figure 3: Barcode vs. RFID - Barcode can identify a product while the RFID tag can uniquely identify a specific object**

Figure 4 provides more detailed list of the many RFID applications that use passive tags. The figure shows the applications and how much money was spent during 2012 and the first half of 2013. The money spent for the second half of 2013 and 2014 was also predicted. If the data holds the same trend for the rest of 2013, the money spent on passive UHF applications will be higher when compared to the previous year. According to the data, the 2012 total value of the RFID market was \$7.67 billion, up from \$6.51 billion in 2011 [25].

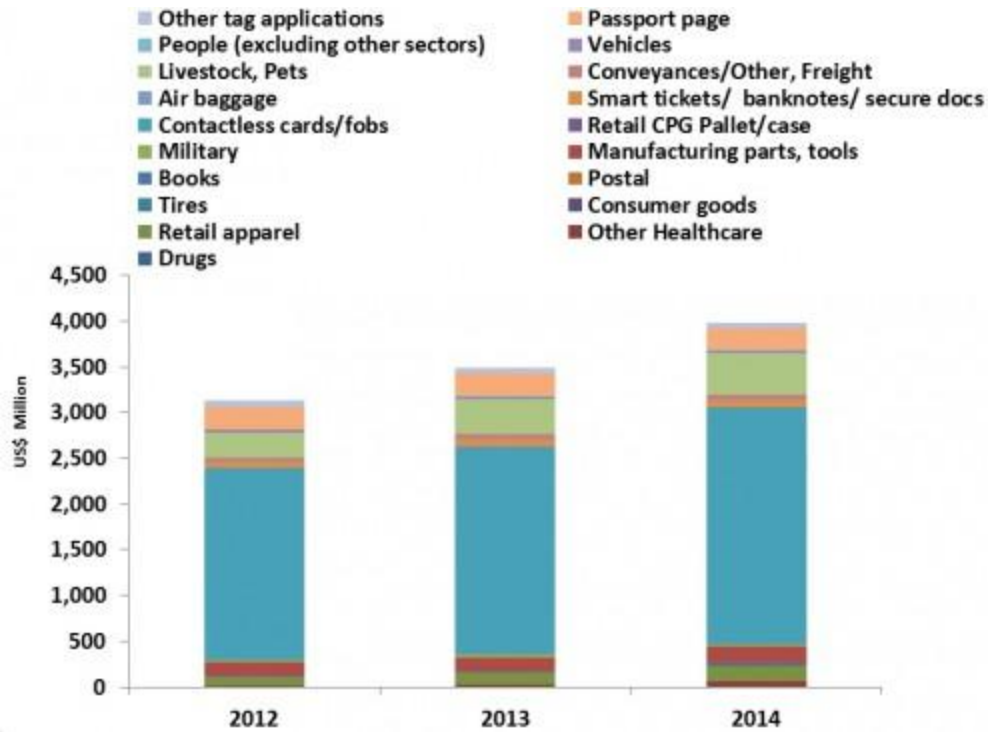


Figure 4: Value of passive tags by application in US\$ millions [25]

There are numerous UHF RFID applications ranging across many industries throughout the world. There are many examples from different industries to help provide solutions that are used today [26][27][28][29][30].

## 2.2 Current Market

Currently there are four methods to accomplish the task of combining tag programming and printing human readable data. Three of the four methods program tags and print simultaneously. The other method does not use a printer to program tags; instead the tags are programmed before they are embedded into media. This is known as preprogramming.

1. Pre Programmed Tags (Laser) – Tags can be preprogrammed before they are embedded into the desired media. A secondary operation requires the media with the embedded tag to undergo the printing process.
2. Thermal Printers –They are limited to smaller media sizes and only one media type can be in the system. The media has to be manually changed every time a different media type is required.
3. Inkjet Printers – Inkjet technology allows for a wider range of media types, but at a higher operating cost.
4. Laser Printers – RFID enable laser printers to offer a wide variety of cut sheet and continuous roll media types. They can offer a wide range of media types and can different media types can simultaneously exist in the system.

**Table 2: RFID-enabled printer quick comparisons**

	Pre Programmed Tags (Laser)	Thermal Printers	Inkjet Printers	Laser Printers
Secondary Process	Yes	No	No	No
Wide range of media Types	No	No	Yes	Yes
Simultaneous Media types	No	No	No	Yes
Cost affective for large quantities	No	No	No	Yes

Many RFID applications that require coded tags also require human readable data. Each of the industries and companies cited earlier in figure 4 require different types of forms, labels, stickers, packing slips, manifest, and documents that must be printed. There is a large range of printing requirements that is associated with RFID document output.

The current RFID-enabled printer market is dominated by thermal printers. Thermal printers have led the RFID-enabled market because of their ability to print small labels. Early adoption of RFID has been driven by the demand of programming tags in small labels. The companies that have succeeded in developing RFID-enabled printers were originally specialized in bar codes printers. There are currently six companies the make up the current market landscape:

- Datamax [datamax-oneil.com](http://datamax-oneil.com)
- Intermec [intermec.com](http://intermec.com)
- Sato [satoamerica.com](http://satoamerica.com)
- Printronix [printronix.com](http://printronix.com)
- Toshiba TEC [toshibatec-ris.com](http://toshibatec-ris.com)
- Zebra [zebra.com](http://zebra.com)

The inkjet RFID-enabled printer market is much smaller in comparison to the thermal printer market. Primarily there is only one main inkjet RFID-enabled printer, the RX-900 Inkjet Printer. The main advantage of the inkjet printer has over thermal printers, is that it can support label sizes ranging from 1 inch wide up to 8.5 inches wide [31]



**Figure 5: Primary inkjet RFID-enable color printer - RX900 [31]**

Another use for inkjet printer technology is its ability to print with metal ink. This capability allows the printer to print RFID antennas directly to the paper. These types of printers are transitioning from the feasibility stage to the production stage [32] [33].

## 2.3 The challenges with Thermal RFID Printing Solutions

As discussed in the previous section, most RFID-enabled environments rely on thermal printers to generate output. There are several disadvantages with thermal printers when it comes to printing documents, labels and forms required to run a business that has invested in this type of technology [34]. Examples of these issues are as follows:

- **Single Use Device** - The thermal printer is dedicated to a single printing task, and is unable to work with multiple forms without the time-consuming manual process of changing media types.
- **Limited Flexibility** – Thermal printer is a single use device and is optimal when the volume is low and the forms are simple. Many businesses have high volume printing environments, which require complex forms. Needing to combine human readable data and RFID-capability into a single media output drives the complexity of the forms. Another source of complexity is the different media sizes required for different types of forms, manifests, packing slips, shipping labels, and bills of lading.
- **Higher Maintenance Costs** – Large operations require different types of printers designated for individual printing tasks. These printers have associated costs for maintenance and procurement of supplies. Thermal printers are single use devices and require all of these costs for one type of operation. Also, when the single use device type of machine goes down, the entire production process comes to a halt until the printer can be replaced or repaired. This “down time” adds cost and the resulting dip in productivity can add up quickly to significant losses.
- **Difficulty with Wide Formats** – Thermal printers were originally designed to print on small formats such as shipping labels. Larger media types, such as 8.5 x 11 or 8 x 14 inch output, is cost prohibitive for thermal printers.
- **Output Quality**- Thermal printers print in lower resolutions, 203-305 dpi (dots per inch). The lower resolution produces print quality issues that lead to unreadable bar codes. Thermal printers transfer the image to the media via a ribbon. This method is known for wear, smearing and distortion print issues.

## 2.4 The benefits of RFID-enabled Laser Printers

There are multiple benefits of laser printers. They can offer higher productivity, device consolidation, forms management, improved print quality, lower costs, and networking capabilities. Each of these benefits are explained in more detail below:

- **Device Consolidation** – Laser printers have network capability, multiple input trays, and multiple output options. This allows for one single device to carry out different required printing functions. Fewer devices lead to lower maintenance and supply cost.
- **Forms management** - The multiple input trays on a single printer allows for one device to accommodate several types of printing functions. The input trays can each hold a different type of media, such as size and material type (i.e. paper forms, labels, etc.). For example, one input tray can hold RFID-enabled media while another input tray can hold



non-RFID media. This can lead to higher productivity because time does not have to be used to manually change the media type for different print jobs.

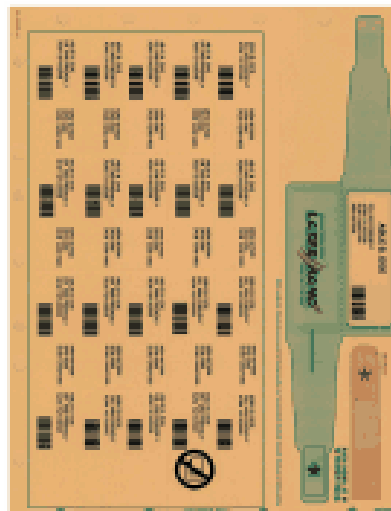
- **Media Flexibility** – Laser printers can print on RFID-enabled media and non-RFID enabled media. This includes the different types of paper, vinyl labels, carbonless paper and other type of media.
- **Better Graphics Capabilities** – Most laser printers operate at 1200 dpi (dots per inch), while thermal printers operate at 305 dpi. This provides a higher print quality for the required human readable data and graphics.

## 2.5 RFID Enabled media

RFID enabled media is an essential component of the total RFID system. The reason is because the tag is embedded inside label type media or attached directly to the media. The RFID enabled media couples human readable and RFID encoded tags into one single document. There are multiple forms of a RFID-enabled media:

- Labels,
- Documents,
- Cards,
- Stickers,
- And standard paper.

These types of RFID-enabled media can be up to 8.5 x 11 inches in size. Below are some examples of RFID enabled media. The first example, figure 6, is a healthcare document used in hospitals. The image below has 21 2-D barcodes. All the bar codes belong to single patient. 20 of the bar codes are stickers that will be applied to medicine containers, such as a pill bottle and medical equipment. The wristband will be applied to the patient. When medicine and medical equipment are brought into the patient's room they are scanned, along with the patient wristband. This process is to help ensure the wrong medicine or medical equipment is not introduced to the patient.

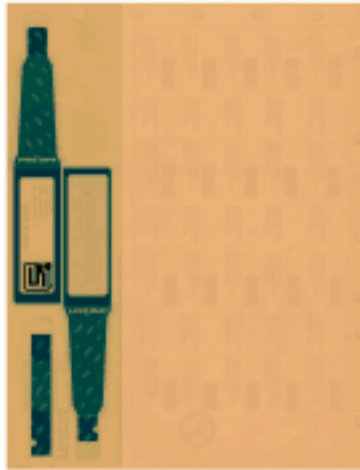


**Figure 6: Medical label with 21 2-D bar codes stickers**

The bar code solution was converted to a RFID solution. 21 RFID tags were embedded underneath each 2-D bar code. This allowed for the patient, medicine and medical equipment to be identified via an RFID system. The value add of the RFID tags is as follows:

- Line of sight – Line of sight is not required for verification, therefore, saves time and effort by the medical staff.
- Automatic verification -- The tags can be checked simultaneously when they enter the room. Any discrepancies will be identified real time and the medical staff will be alerted to the issue.
- Reduces system by-pass – 2-D bar codes can be by-passed by the medical staff. The automatic verification of the RFID system prevents the system by-pass ensuring medical errors are not made.

Figure 7 is an example of a letter size medical wristband with an embedded RFID tag.



**Figure 7: Medical wristband with an embedded RFID tag**

Another example is a letter size combination label with an embedded RFID tag. A combination label is part paper that contains critical human readable and the other part is the label with an embedded RFID tag (see figure 8)



**Figure 8: Combination label with an embedded RFID tag**

Figure 9 is a complete and peeled example of an RFID enabled combination label. The top section is a completed RFID enabled combination label. The bottom section is peeled example of an RFID enabled combination label.



**Figure 9: Front and back of RFID enabled combination label**

Figure 10 shows an A6 size combination label. The Mexican government registers vehicles throughout the country using this form. The vehicle owner keeps the human readable information inside the car, as normal, and applies the RFID label to the windshield. The RFID tag helps in vehicle fraud. This is possible because the vehicle VIN and other unique information are stored on the tag.



**Figure 10: Combination form with embedded RFID tag for vehicle identification**

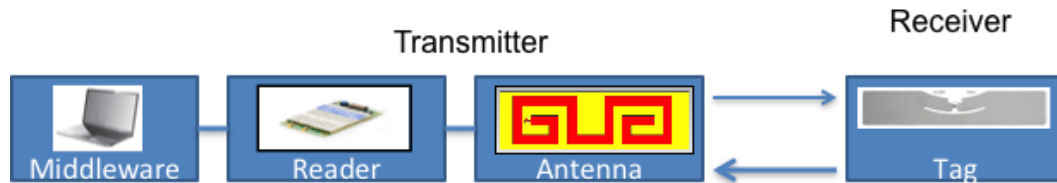
### 3 RFID System Infrastructure

The RFID system infrastructure for tag programming consists of four main components: 1) reader, 2) antenna 3) tag and 4) middleware (i.e. firmware). It is a balancing act between these four main components for the RFID system to perform optimally. This section will discuss the role each component plays in the system and how they interact with respect to one another.

#### 3.1 Simple component system layout

Figure 11 is a diagram of four main components required for tag programming and how they interact with respect to one another. Many publications are available and also explain the RFID system infrastructure in greater detail [35] [36]. In laymen terms, the reader coupled to the antenna transmits an electromagnetic RF signal. It requires an electrical power input source. The tag receives the transmitted RF signal and powers up (i.e. turns on). The microchip on the tag is enabled when the tag is powered up. In this state, information can be read from the chip and sent back to the reader or new information can be written to the chip. This required interaction between the transmitter and receiver is referred to as a “passive” tag.

The communication link established is considered a “reader-tag-reader” link. This is because the antenna can transmit and receive simultaneously [37]. The antenna established a link with the tag and is described as the “reader-tag”. The tag is powered by the electromagnetic field created by the antenna and established a link back to the antenna and is described as the “tag-reader”. In a “reader-tag-reader” communication link the tag is enabled to transmit data back to the antenna or store data in the chip.



**Figure 11: Simple component system layout**

The data from the microchip is then added to an RF signal that is “reflected” by the tag to the reader via the antenna. This process is referred to as passive backscatter (discussed in greater detail in section 4.6.1). The reader contains the electronics to receive this signal from the tag, extract the RFID tag’s code from the signal, and return it to its signal form, and provide the code to the host computer.

The UHF passive tag systems operate on a “talk first” protocol. This is where the tag is not activated until it receives a signal from the antenna. Also, only one reader at a time can energize or create a communication link with a passive tag. If more than one reader attempts to energize a tag simultaneously a condition known as “reader collision” occurs.

## 3.2 Reader

The reader antenna is an important part and has great influence on the performance of the whole RFID system. The antenna reader is supplied power and establishes a communication link with the tag. Another name for the antenna reader is “antenna” and will be referred as such throughout the rest of this paper.

The purpose of the antenna is to transform an RF signal, traveling on a conductor, into an electromagnetic wave in free space. Antennas demonstrate a property known as reciprocity, which means that the antenna will maintain the same characteristics regardless if it is transmitting or receiving. The reader will provide an input signal to the antenna where it will create a radian sphere (near field) or emit radiation distributed into space (far field).

Embedded inside the reader are powerful microchips and memory, which controls a radio transmitter and receiver. The reader is also called an interrogator because it recognizes a tag when it enters the field of view and establishes a link for communication.

## 3.3 Antenna Types: Reader Antenna and Tag Antenna

RFID antennas can be divided into two classes: the reader antenna and the tag antenna. The reader antenna transmits the electromagnet energy to activate or awaken the tag, realizes the data transfer and sends the instructions to the tag. The reader antenna receives information from the tag. The tag antenna not only transmits the wave carrying the information stored in the tag, but also needs to catch the wave from the reader to supply energy for the tag operation.

For simplicity the reader antenna will be referred to as the “antenna” and the tag antenna will be referred to as the “tag” for the remaining of this paper.

### 3.3.1 Antenna

An antenna is a device that transmits and/or receives electromagnetic waves. Most antennas are resonant devices, which operate efficiently over a relatively narrow frequency band. An antenna must be tuned to the same frequency band that the radio system to which it is connected operates in, otherwise reception and/or transmission will be impaired.

The antenna is coupled with the reader to work as both the transmitter and a receiver. There are several antenna characteristics and propagation channel properties that are critical for antenna performance. The design considerations for the antenna are as follows [36][37][38][39][41]:

- Antenna characteristics
  - Operating frequency band,
  - Gain characteristics (maximum gain, radiation patter, beamwidth, etc.),
  - Directivity
  - Impedance Matching
  - VSWR and Reflected Power
  - Polarization
  - Location
  - Sensitivity to nearby objects with different properties,
- Propagation channel properties
  - Path loss

- Radiation patterns
- Spatial and temporal fading statistics

### Gain

The gain of the antenna directly impacts the tag read range. It is important to understand the relationship between the linear gain of the antenna and its circular gain. Linear gain is referenced to a linear isotropic source and measure in dBil, while circular gain is referenced to a circular polarized isotropic source measured in dBic. The power gain also affects the ability of the antenna to concentrate energy in a particular direction.

### Directivity

Directivity is the ability of an antenna to focus energy in a particular direction when transmitting or to receive energy better from a particular direction when receiving. The relationship between gain and directivity:  $\text{Gain} = \text{efficiency}/\text{Directivity}$ . We see the phenomena of increased directivity when comparing a light bulb to a spotlight. A 100 watt spotlight will provide more light in a particular direction than a 100 watt light bulb, and less light in other directions. We could say the spotlight has more "directivity" than the light bulb. The spotlight is comparable to an antenna with increased directivity. An antenna with increased directivity is hopefully implemented efficiently, is low loss, and therefore exhibits both increased directivity and gain.

A directional antenna is one that radiates its energy more effectively in one (or some) direction than others. Typically, these antennas have one main lobe and several minor lobes. Examples of directional antennas are patches and dishes.

An Omni directional antenna is an antenna that has a non-directional pattern (circular pattern) in a given plane with a directional pattern in any orthogonal plane.

### Impedance Matching

For efficient transfer of energy, the impedance of the radio, the antenna, and the transmission line connecting the radio to the antenna must be the same. Radios typically are designed for 50 ohms impedance and the coaxial cables (transmission lines) used with them also have a 50 ohm impedance. Efficient antenna configurations often have an impedance other than 50 ohms; some sort of impedance matching circuit is then required to transform the antenna impedance to 50 ohms.

### VSWR and Reflected Power

The Voltage Standing Wave Ratio (VSWR) is an indication of how good the impedance match is. VSWR is often abbreviated as SWR. A high VSWR is an indication that the signal is reflected prior to being radiated by the antenna. VSWR and reflected power are different ways of measuring and expressing the same thing. A VSWR of 2.0:1 or less is considered good. Most commercial antennas, however, are specified to be 1.5:1 or less over some bandwidth. Based on a 100 watt radio, a 1.5:1 VSWR equates to a forward power of 96 watts and a reflected power of 4 watts, or the reflected power is 4.2% of the forward power.

### Bandwidth

Bandwidth can be defined in terms of radiation patterns or VSWR/reflected power. Bandwidth is often expressed in terms of percent bandwidth, because the percent bandwidth is constant relative to frequency. If bandwidth is expressed in absolute units of frequency, for example MHz, the

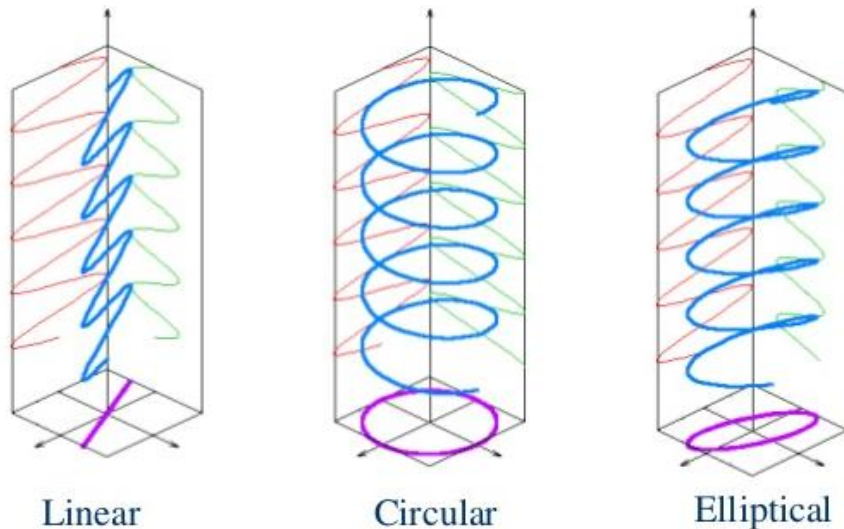
bandwidth is then different depending upon whether the frequencies in question are near 150, 450, or 825 MHz.

### Polarization

Polarization is defined as the orientation of the electric field of an electromagnetic wave. Polarization is, in general, described by an ellipse. Two often used special cases of elliptical polarization are linear polarization and circular polarization. The initial polarization of a radio wave is determined by the antenna that launches the waves into space. The environment through which the radio wave passes on its way from the transmitting antenna to the receiving antenna may cause a change in polarization.

For maximizing tag range, antenna polarization of the tag must be matched to that of the antenna. Most RFID tags are linearly polarized. RFID tags that are currently on the market are linearly polarized. There are two additional polarization types: circular and elliptical. The linear polarized antennas require the tag to have parallel or perpendicular orientation with respect to the antenna. The antennas use circular polarization to ensure the tag can be read at any orientation angle.

As mentioned in the earlier paragraph, there are two types of RFID antenna polarization types: 1) dipole antennas (linear polarization) or 2) helix, crossed dipoles and patch (circular polarization). The dipole antenna produces an electromagnetic wave that propagates entirely in one plane (vertical plane or horizontal plane) in the direction of the signal propagation.



**Figure 12: Antenna Polarization types [42]**

The helix, crossed dipoles and patch antennas produce an electromagnetic wave that propagates in two planes creating a circular effect (like a corkscrew) making one complete revolution in a single wavelength. The linear polarization type antennas are optimal when the tag location is known. The circular polarization type antennas are optimal when the tag location is unknown (see figure 12 for polarization types).



## Path Loss

Path loss between the antenna and tag with an established communication link strongly depends on the propagation environment. This will be discussed in further detail in chapter 4

## Antenna Placement

Correct antenna placement is critical to the performance of an antenna. The distance from the tag to the antenna directly impacts tag programming. The surrounding materials are also critical. This is especially true for metal material or any similar material that can reflect electromagnetic waves and interfere with tag programming.

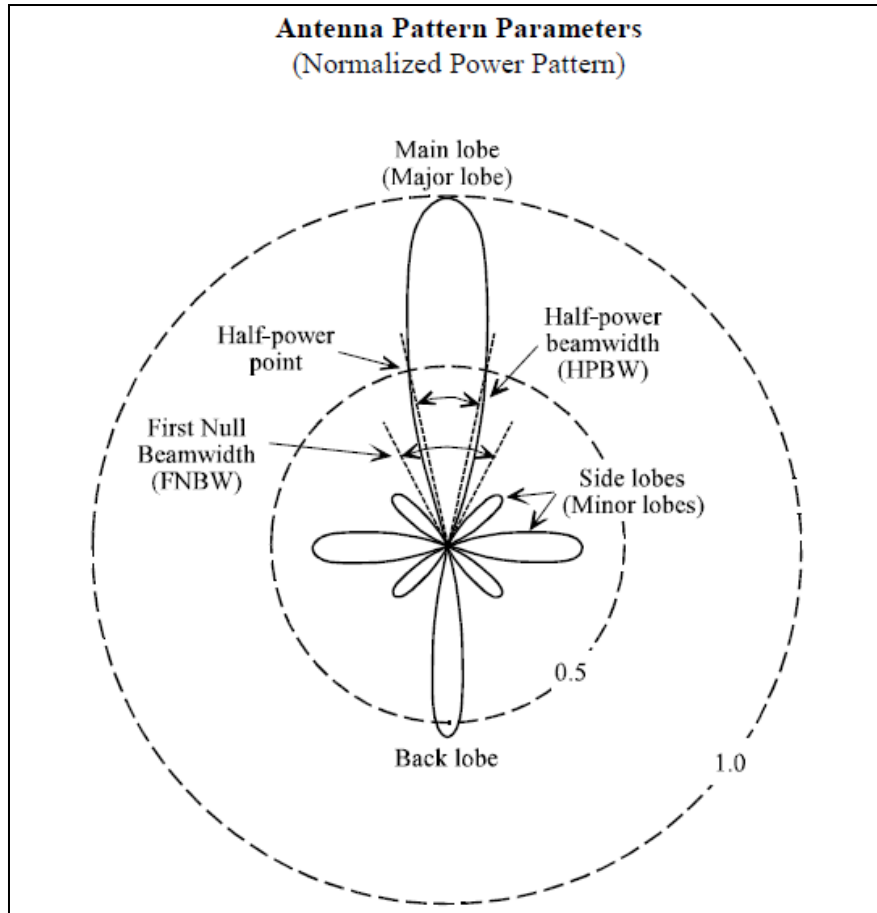
## Radiation patterns

The radiation or antenna pattern describes the relative strength of the radiated field in various directions from the antenna, at a fixed or constant distance. The radiation pattern is three-dimensional, but it is difficult to display the three dimensional radiation patterns in a meaningful manner; it is also time consuming to measure a three-dimensional radiation pattern. Often radiation patterns are measured that are a slice of the three-dimensional pattern, which is of course a two-dimensional radiation pattern which can be displayed easily on a screen or piece of paper. These pattern measurements are presented in either a rectangular or a polar format.

Antennas that are being used as a transmitter do not radiate uniformly in all directions. This is the same for antennas being used as a receiver; they do not detect energy uniformly from all directions. The directional selectivity of an antenna is characterized in terms of its radiation pattern. A radiation pattern is a plot of the relative strength of radiated field as a continuous of the angular parameters for a constant radius. There are four main antenna radiation patterns [43]:

- Isotropic pattern – an antenna pattern defined by uniform radiation in all directions, produced by an isotropic radiator (point source, a non-physical antenna which is the only truly non-directional antenna).
- Directional Pattern – a pattern characterized by more efficient radiation in one direction than another (all physically realizable antennas are directional antennas).
- Omni directional Pattern – a pattern which is uniform in a given plane.
- Principal Plane Patterns – the E-plane and H-plane patterns of a linearly polarized antenna.
  - E-Plane – the plane containing the electric field vector and the direction of maximum radiation
  - H-Plane – the plane containing the magnetic field vector and the direction of maximum radiation.

Radiation patterns are communicated through graphical representation of the antenna radiation properties as a function of position using spherical coordinates (i.e. radial plots). The radiation pattern plots are constructed of different type of lobes.



**Figure 13: Radiation Patterns - Antenna Pattern Parameters [43]**

Below are the descriptions of the antenna pattern parameters [43]:

- Radiation Lobe – a clear peak in the radiation intensity surrounded by regions of weaker radiation intensity.
- Main lobe – also called major lobe or main beam – radiation lobe in the direction of maximum radiation.
- Minor Lobe – any radiation lobe other than the main lobe.
- Side Lobe – a radiation lobe in any direction other than the direction(s) of intended radiation.
- Back Lobe – The radiation lobe opposite to the main lobe.
- Half – Power Beamwidth (HPBW) – the angular width of the main beam at the half – power points.
- First Null Beamwidth (FNBW) – angular width between the first nulls on either side of the main beam.

### 3.3.2 Basic Far Field Antenna Types

#### Patch

Much research has been conducted in the area of patch antennas [44] [45] and only the general characteristics will be discussed. A micro strip or patch antenna is a low-profile antennas that has a number of advantages over other antennas – it is lightweight, inexpensive, and easy to integrate with other electrical components. These types of antennas are mono or dual polarized and can program far field tags only.

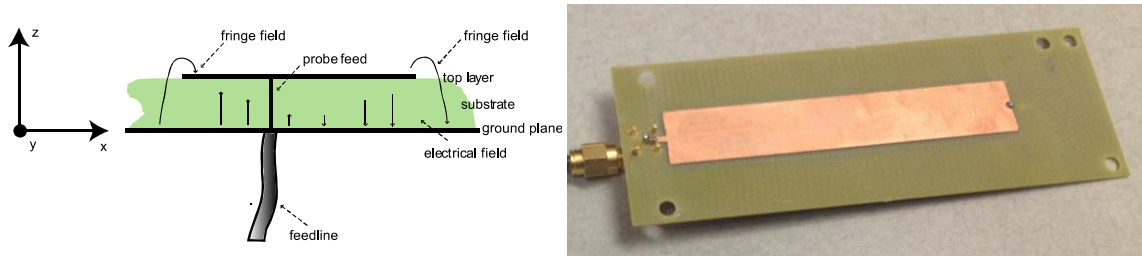


Figure 14: (right) Cross section of a patch antenna and (left) path antenna

#### Meander

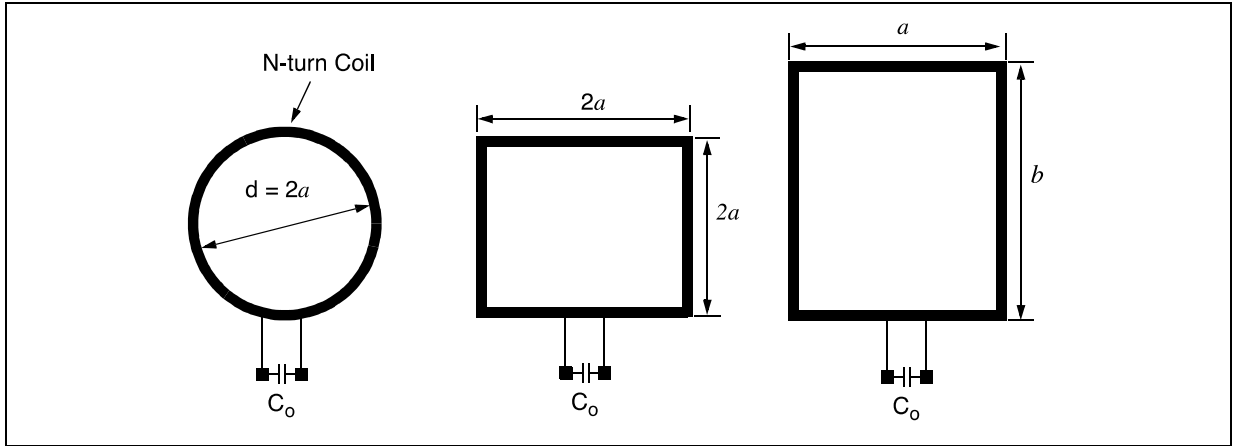


Figure 15: Meander Antenna

### 3.3.3 Basic Near Field Antenna types

Much research has been conducted in the area of basic near field antennas [46] [47] [48] [49] and only the general characteristics will be discussed. The near field antenna types use inductive coupling to transfer data to and from the tag in a RFID system. Near-field antennas use loop structures to generate an electromagnetic field for tag programming. The loop structure allows for the current in the loop circuit antenna to be designed to keep consistent. In turn, the magnetic field distribution around the loop's axis will be concentrated and enhanced, which is easier for the tag to receive more energy from the readers' antenna. Near field antennas are omni directional and can program near and most far field tags.

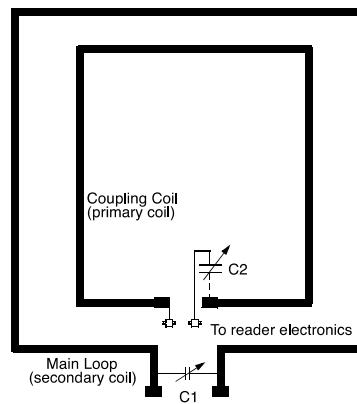
The figure below has three examples of loop antennas: Circular, square and rectangle. All three produce an electromagnetic field around the antenna.



**Figure 16: Near Field Antenna Configurations [47]**

The near field antenna can be made of either a single coil that is typically forming a series resonant circuit or a double loop (i.e. transformer) antenna coil that forms a parallel resonant circuit.

The figure below is an example of a transformer loop antenna. The main loop (secondary) is formed with several turns of a wire. The other loop is called a coupling loop (primary), and it is formed with less than two or three turns of a coil. This loop is placed in a very close proximity to the main loop. Most designs place the primary loop on the inside edge and not more than a couple centimeters away from the main loop. The purpose of this loop is to couple signals induced from the main loop to the reader (or vice versa) at more reasonable matching impedance.



**Figure 17: A transformer loop antenna for a reader [47]**

The next two figures are antennas used to conduct tests for this research. The antenna on the right is an array of four near field loop antennas. The antenna consists of a square outer loop with a circular inner loop. The antenna on the left is a single loop antenna with two rectangular outer loops.

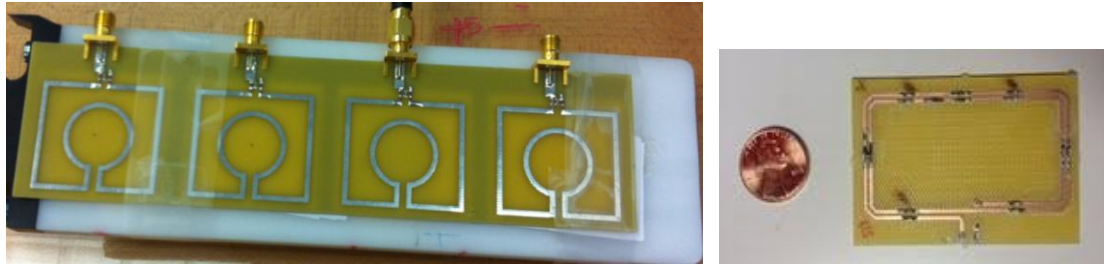


Figure 18: Right: an array of four loop antennas. Left: single loop antenna

### 3.4 Antenna and Tag Design Best Practices

Based upon the information in antenna and tag sections the following best practices should be used for an optimal RFID system.

#### Antenna

In most cases the position of the orientation of the identified object is random, and the manner for attaching the tag to the identified object is random, and the manner for attaching the tag to the identified object is unfixed. Because of this the antenna should be a circularly polarized antenna. This will help avoid the polarized loss when the orientation of the identified object is changed.

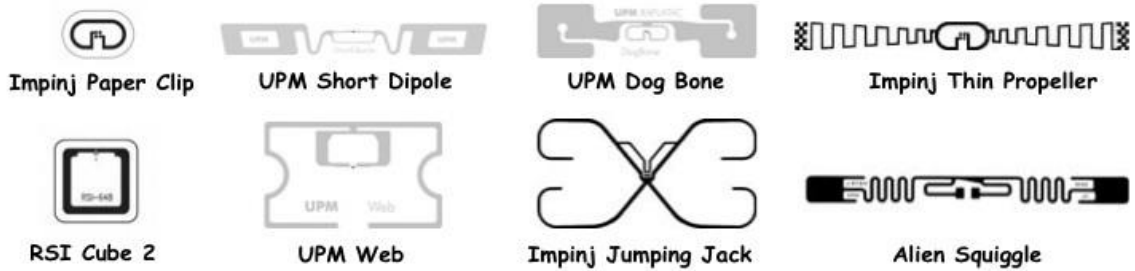
#### Tag

The tag will be attached to an identified object, therefore, the size of the tag must be small enough and the antenna should be small in size. In most cases, the tag antenna should have omnidirectional radiation or hemispherical coverage. For common applications, the tag antenna should be low-cost and easy to fabricate for mass production.

### 3.5 Tags

The purpose of the tag is to contain unique information about the item to which it is attached. The tag can be thought of as an assembly that includes an antenna and an integrated circuit (i.e. microchip). The antenna receives the radio signal from and to the reader, while the integrated circuit acts as the brains for the tag to talk to and understand the signals from the reader. There is a wide range of RFID tags and it is difficult to find two that are the same. Tag classification is based up on frequency, passive / active / semi passive and tag memory.

There are three main types of tags: 1) passive, 2) active and 3) semi passive. Passive tags do not have a standalone power source and become operational powered when they enter the field created by the reader. Active tags perform the same operations as the passive tags, but include a battery for a power source. The active tags are always operational, but must be inside the antenna field to be read. The added power allows the active tags to be read at longer distances. The semi passive tags are similar to the active type because they include a battery for a power source, but they combine a sensor enabling environment sensing. The sensing capacity can be for such environmental monitoring as temperature, shock or vibration and movement.

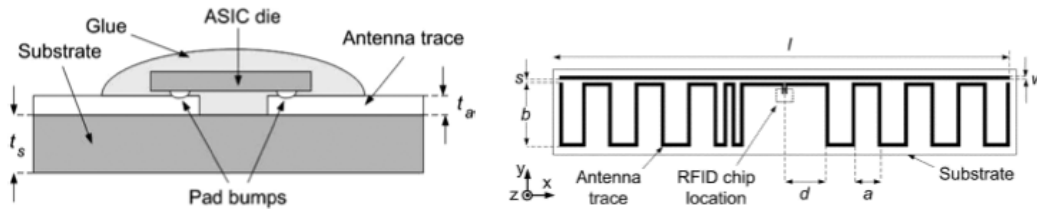


**Figure 19: Examples of the different types of commercial passive UHF tags**

There are three types of tag memory: 1) read-only, 2) read / write tags and 3) combination tags. Read-only tags store data that cannot be changed. Read / write tags store data that can be altered or re-written over the original data. Combination tags have some data that is permanently stored on the tag, along with additional memory capacity that is available for updates and / or sensing.

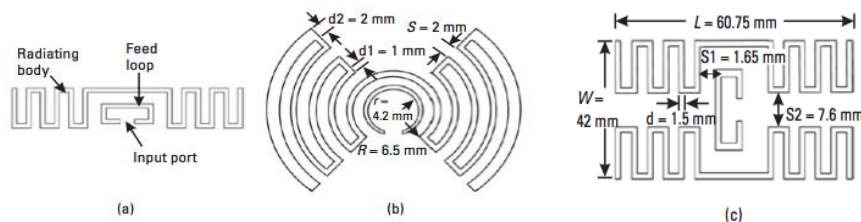
The design requirements for the tag are as follows:

1. **Size and form** – This depends on where the tag is embedded or attached on the desired objects (cardboard boxes, file folders, printed labels, etc).
2. **Tag construction** – how the IC is attached to the antenna will vary between tag types. This is important for life of the tag because some designs are much more robust than others. Tag construction can be difficult to determine due to the small size. Material engineering methods are useful coupled with specific life tests.



**Figure 20: Tag construction (left) and antenna type (right) [50]**

3. **Tag Antenna type** –The antenna type will impact the performance of the tag. Below are three examples of tag antenna types. An antenna can be characterized by the feed loop and by the radiating body. Below are examples of a) typical configuration, b) arc configuration and c) dual body configuration.



**Figure 21: (a) typical configuration, (b) arc configuration and (c) dual body configuration [51]**

4. **Integrated circuit type** – The IC type depends on the speed of the tag in which the tags needs to be read or programmed.

5. **Memory requirements** – Most application require the “license plate” mode. 96-128 bit tags are optimal for this type of application. More sophisticated tags are available on the market with larger capacity.
6. **Tag Classes** – The EPC framework has outlines for six classes of tags. They are discussed in the next section under the EPC (electronic product code).
7. **Tag Environment** – This includes the dielectric loading, proximity to Metal, Proximity to water and lossy environment.

The figure below represents the parameters for optimal tag design.



**Figure 22: The parameters of optimal tag design**

The tag is a critical component of the RFID system. Matching the optimal tag for each application is critical. Tags are designed for specific applications, this is the main reason there are a wide variety of tags on the market. The table below is a summary of seven tags and their optimal application.

**Table 3: Tag summary with optimal application [52]**

Antenna	Dimensions	Pallet	Case	Item	Long Range	Range-bridging	Short Range	Worldwide Operation
ThinPropeller	92 mm x 8 mm	✓	✓		✓			✓
Satellite	32 mm x 18 mm		✓	✓		✓		✓
PaperClip	20 mm x 8 mm			✓		✓		✓
Trellis	22 mm x 8 mm			✓		✓		✓
Blade	15 mm x 8 mm			✓			✓	✓
Button	12 mm round			✓			✓	✓
Square Button	11 mm square			✓			✓	✓

## 3.6 Standards

### 3.6.1 ISO

One of the major standards bodies in the world is the ISO (international organization for standards). ISO is an organization of the national standards institutes of 146 countries, on the basis of one member per country, with a Central Secretariat in Geneva, Switzerland, that coordinates the system.

ISO is a nongovernmental organization: its members are not, as is the case in the United Nations system, delegations of national governments. Nevertheless, ISO occupies a special position between the public and private sectors. This is because, on the one hand, many of its member institutes are part of the governmental structure of their countries, or are mandated by their government. On the other hand, other members have their roots uniquely in the private sector, having been set up by national partnerships of industry associations.

Therefore, ISO is able to act as a bridging organization in which a consensus can be reached on solutions that meet both the requirements of business and the broader needs of society, such as the needs of stakeholder groups like consumers and users.

ISO manages several standards related to the area of RFID. ISO 11784/11785 relates to animal tracking. ISO 14443A/14443B relates to proximity style RFID while ISO 15963 relates to vicinity tagging. ISO 18000 pertains to radio frequency identification for item management, and contains six subsections covering differing frequency ranges. There are many other ISO standards relating to test methods, APIs and conformance standards.

### 3.6.2 INCITS

The International Committee for Information Technology Standards (INCITS) is the primary U.S. focus of standardization in the field of Information and Communications Technology (ICT) encompassing storage, processing, transfer, display, management, organization, and retrieval of information. As such, INCITS also serves as the American National Standards Institutes (ANSI)



Technical Advisory Group for ISO/IEC Joint Technical Committee 1 (JTC 1). JTC 1 is responsible for international standardization in the field of information technology. INCITS is accredited by ANSI and operates under its rules, designed to ensure that voluntary standards are developed by the consensus of directly and materially affected interests.

### 3.6.3 ICAO

The International Civil Aviation Organization (ICAO) is another standards body creating RFID related standards. In 2003, ICAO specified the technical requirements for RFID technology used in electronic passports. These specifications were published in ICAO Doc 9303, and are the focus of the ePassport activities taking place within Department of State.

### 3.6.4 NIST

The National Institute of Standards and Technology, NIST, is a non-regulatory federal agency within the U.S. Commerce Department's Technology Administration. NIST's mission is to develop and promote measurement, standards, and technology to enhance productivity, facilitate trade, and improve the quality of life. NIST is currently working on RFID technology in the construction industry, and has ties into smart card technology through its encryption standards.

### 3.6.5 EPCglobal

Another very visible standards body applicable to RFID devices is EPCglobal. EPCglobal was formerly known as the Auto- ID Center, originally started at Massachusetts Institute of Technology (MIT). The Auto- ID Center originally sought to bring users of RFID together with technology providers to create an item identification standard as well as to promote technologies to carry the identification. This identification standard, known as the Electronic Product Code, can be thought of as a serialized version of the common Universal Product Code (UPC) found on many consumer goods. However, a key distinction is that while the UPC designates a class of items (i.e., all copies of a certain product sold in the U.S. will have a common barcode) the EPC designates an instance of an item (e.g., each copy of that CD will be identifiable from others).

The EPC, a 96 bit number, is expected to provide an address space of roughly 30 trillion unique identifiers. All users of the EPCglobal system will also have control over their address space – no repeating will be allowed.

EPCglobal has a number of specifications for RFID, namely Class 0/Class 1 UHF and Class 1/HF. The latter is equivalent to the ISO 15963 standard. EPCglobal's UHF Gen2 is the specification that the U.S. DoD (department of defence) and most retailers around the world are coalescing around. Since it is becoming a de facto standard, and because so many technology providers are planning or have announced production of Gen2 products, the RF Feasibility team is favoring this standard as the key guideline for technology selection.

### 3.6.6 Resources

RFID is a hot technology topic, and there is tremendous hype, disinformation, and general noise on the web. Below are several websites with good information for reference.

- <http://www.incits.org>
- <http://www.iso.org>
- <http://www.epcglobalinc.org/index.html>
- <http://www.aimglobal.org/>
- <http://www.rfidjournal.com>

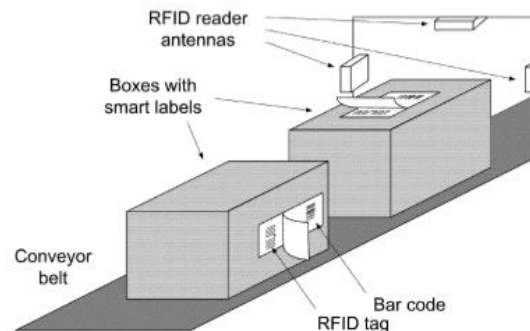
- <http://www.rfidhandbook.de>
- [http://www.epcglobalinc.org/public\\_policy/public\\_policy\\_guidelines.html](http://www.epcglobalinc.org/public_policy/public_policy_guidelines.html)

## 4 Explanation of the RFID system and Communicates Types

### 4.1 RFID Infrastructure

It is important to note that the design requirements are dependent upon the type of application the RFID is to be implemented. System level design requirements are as follows:

1. **Frequency band** – Desired frequency band of operation depends on the regulations of the country where the tag will be used.
2. **Read Range** – the maximum required distance tags must be read from the reader.
3. **Mobility** – the speed in which tagged objects are traveling and read simultaneously. This means that the tag spends less time in the read field of the RFID reader.
4. **Cost / budget** – the cost must be matched to the system design requirement. Issues will arise if the design requirements are high and the budget is low. At the same time, an over designed system is not cost efficient.
5. **Environment** – They selected equipment must work reliably over long periods times in the local environment (i.e. Temperature, humidity, applied stresses, etc).



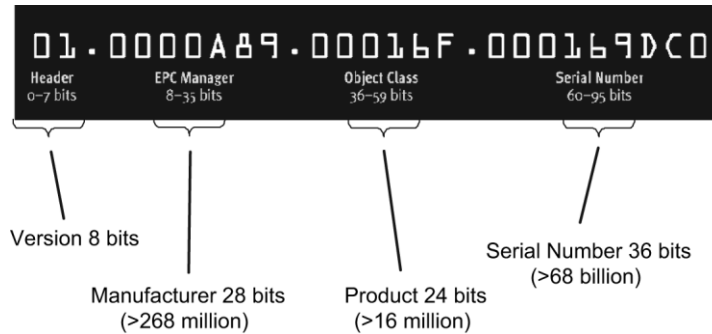
**Figure 23: Mobility - RFID conveyor belt application [53]**

### 4.2 Electronic Product Code (EPC)

The electronic product code (EPC) is the unique, item-level identifier for the item to which it is attached. The actual information stored in the EPC is considered a “pointer” because it points to the real information in a database. There are four elements of a 96-bit capacity EPC:

1. The header (or version): Identifies the length of the EPC number, including the code and version in use (up to 8 bits).
2. The EPC Manager (or manufacturer): identifies the company or entity responsible for managing the two EPC elements (up to 28 bits)

3. The Object Class (or Product): identifies the class of item (Up to 24 bits).
4. The Serial Number: identifies a unique serial number for all items in a given object class (up to 36 bits).



**Figure 24: 96-bit EPC [54]**

The electronic product code (EPC) framework has six tag classes. The range of capability increases as the tag class increases.

**Table 4: Electronic Product Code (EPC) Tag Classes [55]**

EPC Tag Class	Tag Class Capabilities
<b>Class 0</b>	Now obsolete. EPC number is factory programmed onto the tag and is read-only.
<b>Class 1</b>	Now obsolete. EPC, passive RFID class characterized by the ability to write tags in the field. Also refers to the EPCglobal specification defining the tag-reader protocol for RFID systems of this class.
<b>Class 1 Gen 2</b>	Alternative name for Generation 2, the second generation of the EPCglobal Class 1 specification, featuring a number of advancements that significantly boosted system performance over Class 1 Generation 1.
<b>Class 2</b>	An EPC RFID class characterized by the ability to read and write tags in the field and to support expanded memory structures in the tag. This class is largely obviated by Gen 2, which delivers robust read-write capability and a significant subset of the memory capability found in Class 2. No Class 2 specification has been ratified as a result.
<b>Class 3</b>	An EPC RFID class characterized by passive tags that are battery assisted to enable longer range and the addition of sensors and other external functions such as temperature monitors.
<b>Class 4</b>	The EPC RFID class that corresponds to active transmitter RFID, in which the tag broadcasts first using a battery-powered, active transmitter.

#### 4.2.1 Frequencies

A RFID system comprises of three hardware components and a software component (discussed in chapters 6 & 7) The frequency types have three main parameters: transmission range, data speed, and cost. The transmission range is the linear distance between the antenna and tag where data can be optimally transferred. Data speed is the rate data can be transferred between the antenna and tag. Cost is the cost per tag. Table 2 has the frequency type and corresponding parameters.

**Table 5: Frequencies, descriptions and ranges**

Frequency Band	Description	Read Range	Data Speed	Approximate tag cost in volume (2006) US \$
120-150 kHz	Low frequency (LF)	10 cm	Low	\$1
13.56 MHz	High Frequency (HF)	10 cm -1 m	Low to Moderate	\$0.50
433 MHz	Ultra-high frequency (UHF)	1-100 m	Moderate	\$5
865-868 MHz (EU) 902-928 MHz (US)	Ultra-high frequency (UHF)	1-12 m	Moderate to High	\$0.15 (passive tags)
2450-5800 MHz	Microwave	1-2 m	High	\$25 (active tags)
3.1-10 GHz	Ultra wide band	Up to 200 m	High	\$5

Ultra-high frequency (UHF) is the chosen frequency because of the transmission range, high data speed potential and low cost for passive tags.

#### 4.2.2 Communication Types

The method in which the RFID reader and tag communicate with one another is known as the RFID coupling mechanism. The type of coupling mechanism used depends on several aspects of the RFID system including the frequency, range and other RFID hardware elements. The range of the RFID system can generally be categorized into three different mechanisms. The three types with corresponding parameters are listed below in Table 3.

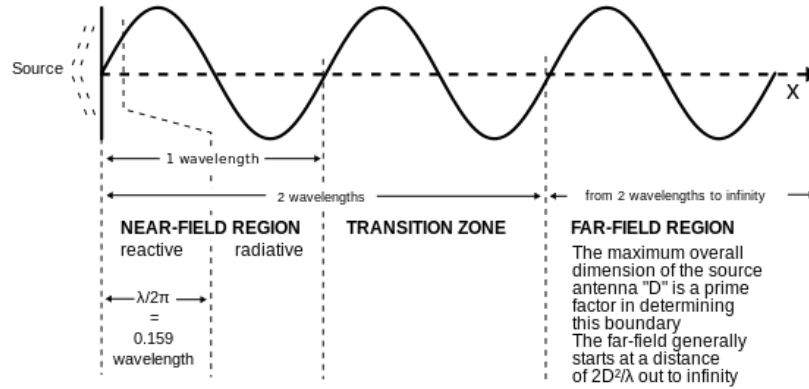
**Table 6: RFID coupling mechanisms and their parameters.**

Coupling Mechanism	Range Type	Transmission Range	Communication Type
<b>Capacitive</b>	Close	Within 1 centimeter	Near Field (reactive)
<b>Inductive</b>	Remote	Between 1 cm and 1 meter	Near Field (radiative)
<b>Backscatter</b>	Long	More than 1 meter	Far Field

The RFID coupling mechanism choice will depend on upon the intended application. In general, capacitive RFID coupling is used for very short ranges, inductive RFID coupling is for slightly longer ranges and RFID backscatter coupling is used when long distances are needed.

#### 4.2.3 Field Regions Types and Boundaries

There are four different types of fields created around the antenna: 1) reactive near field, 2) radiative near field, 3) transition zone, 4) and far field region. Each RFID system communicates between the antenna and tag by using near field or far field systems. The near-field systems use electromagnetic induction where closed loops magnetic waves are formed. The far-field system uses modulated backscatter coupling, where electromagnetic waves propagated into free space.



**Figure 25: RFID regions (Near field, far field and transition zone) [56]**

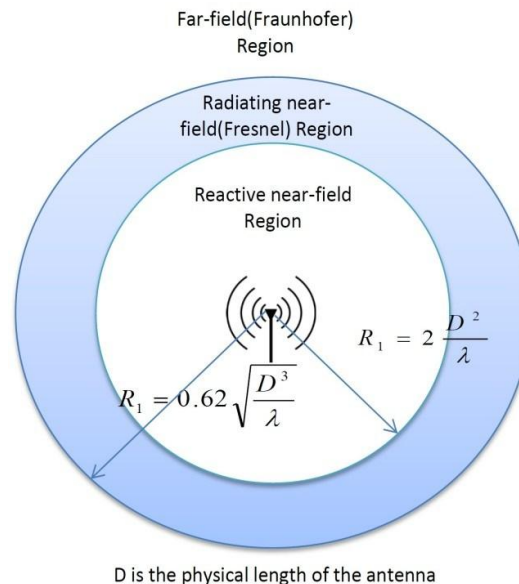
The electromagnetic fields are having both electric and magnetic components and vary characteristically with distance from their source. From Figure 10, it is clear that the distance from their source, which means that they electromagnetic field components are different, defines the four regions. In order to define the distance the boundaries of the four regions the wavelength must be defined. The wavelength can be defined as:

$$\lambda = \frac{c}{f}$$

**Equation 1: Wavelength**

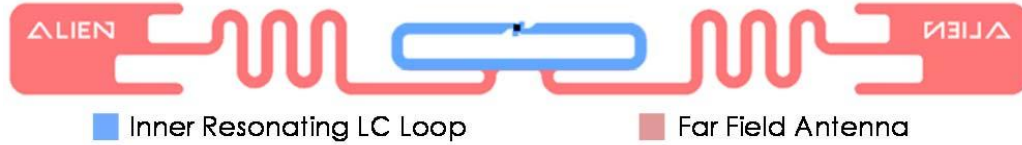
where  $\lambda$  is the wavelength of the frequency band (meters),  $c$  is the speed of light  $3 \times 10^8$  m/s, and  $f$  is the frequency at which the RFID system operates (Hz or  $\frac{1}{sec}$ ).

The figure below shows the different field regions bases upon antenna diameter of the loop.



**Figure 26: Antenna Field Regions [57]**

It is worth noting that UHF passive RFID tags have two resonating elements to the design. One is the resonating LC loop for near field communication and the other is the far field antenna for far field communication. This built in feature provides the tag with near and far field communication capabilities.



**Figure 27: Two RFID resonators built into a single UHF RFID tag antenna [58]**

The boundaries of the zones are not clearly defined, but the general characterizes of the field distributions in each of the four regions can be. There are multiple papers that have been publishes that help describe the field regions [59] [60][61][62] and the following is focuses on the main characteristic.

#### 4.2.3.1 Reactive Near-Field

The near field region has two sub groups: reactive and radiating. The reactive near field region is in the immediate vicinity of the antenna and is characterized by standing (stationary) wave, which represent stored energy. In this region, the fields are predominantly reactive fields, which mean the E- and H- fields are out of phase by 90 degrees to teach other. Closed magnetic loops are formed and can be thought of as energy storage fields. The boundary of this region is defined by the following two equations.

The first equation is for antennas electrically small compared to a wavelength  $\lambda$ .

$$r_{reactive} < \frac{\lambda}{2\pi}$$

**Equation 2**

The second equation is for antennas electrically large antennas,

$$r_{reactive} < 0.62 \sqrt{\frac{D^3}{\lambda}}$$

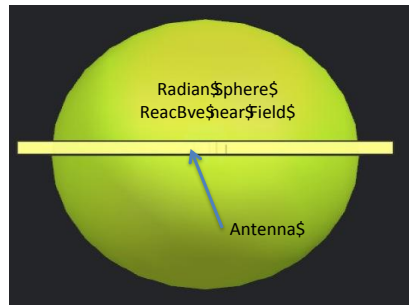
**Equation 3**

The reactive near-field region exists very close to the antenna. The reactive components of the electromagnetic fields are very large with respect to the radiation fields. The reactive fields are created from the electromagnetic charges on the structure, they do not radiate but rather from a critical part of the radiating mechanism. The field components decay rapidly with the square or cube of the distance from the source. Because of this rapid rate of decay, the reactive near field is considered negligible relative to the radiation fields at distances of greater than a wavelength from the source.

Reactive and radiation fields of equal magnitudes are produced at distances of  $\frac{\lambda}{2\pi}$  from the source. This is only true for small infinitesimal magnetic or electrical current. Any other source current distribution will cause the distance, or crossover point, to be at a smaller. There are no reactive field regions components for an infinite plane wave.

#### 4.2.3.1.1 Radian Sphere

The radian sphere is referred to as the distance where anything inside is the reactive near field. Because of the changes in the electromagnetic fields occur gradually, the boundary is not exactly defined. The field inside the sphere is comprised of closed magnetic loops. At the surface of the radian sphere is where the closed magnetic loops break away and transition into plane wave that propagate into free space [62].



**Figure 28: Radian Sphere, which represents the reactive near field**

#### 4.2.3.2 Radiating Near-Field

The radiating near field region (or Fresnel) is the region between the reactive near field region and the transition zone. In this region, the radiation fields are dominant and the field distribution is dependent on the distance from the antenna. This portion of the field is characterized by radiating (propagating) waves, which represent transmitted energy. The magnetic closed loops transition into propagating waves. Unlike the far field region the radiation pattern is sensitive to distance. The equations used depend on the antenna radius compared to  $\lambda$ , same as reactive near field.

The first equation set of is for antennas electrically small compared to a wavelength  $\lambda$ .

$$r_{radiating} = \lambda$$

**Equation 4**

The second equation is for antennas electrically large antennas,

$$R_{Radiating} < \frac{2D^2}{\lambda}$$

**Equation 5**

Therefore, the boundary can be defined as:



$$\frac{\lambda}{2\pi} < r < 1 \text{ wavelength}$$

**Equation 6**

or

$$R_{reactive} < 0.62 \sqrt{\frac{D^3}{\lambda}} < R_{Radiating} < \frac{2D^2}{\lambda}$$

**Equation 7**

The radiating near-field region is located directly after the reactive near-field region. In the radiating near-field region the radiation pattern is dependent on the distance from the antenna as well as the observation angle. This is because the distance from different parts of the antenna to the observation point varies considerably and consequently the phase and amplitude of field contributions from the different parts changes proportionally.

As the distance from the antenna increases a point is reached when the relative amplitude and phase of the components from different parts of the antenna become independent of distance. This is known as the far-field region.

#### **4.2.3.3 Transition Zone**

The region between near field and far field is called the transition zone. This is because the transition zone contains characteristics found in the near field and the far-field regions. The boundaries are theoretical and usually require several measurements to characterize the field type. Figure 6 depicts the two regions and the transition zone between them. The boundaries are not rigid, but in general are defined between 1 and 2 wavelengths. The transition represents the region where the electromagnetic waves separate from forming magnetic closed loops and begin to propagate into free space as plane waves.

It is difficult to predict which type of electromagnetic fields components combination will be created in the transition zone. Because of this it is best practice to empirically determine the field component through testing.

#### **4.2.3.4 Far-Field Region**

The far-field region is farthest away from the antenna where the field distribution is essentially independent of the distance from the antenna (propagating waves). The far-field region is where the components from different parts of the antenna become independent of distance. This means that the angular radiation characteristics are independent of distance. The distance where the far-field region begins is commonly defined by

$$R > \frac{2D^2}{\lambda}$$

**Equation 8**

Where D is the largest dimension of the aperture. At this distance the difference in path length between the center of the aperture and the edge of the aperture is  $\frac{\lambda}{16}$  corresponding to a phase difference of 22.5 degrees.

#### 4.2.3.5 Region Field Summary

Table 7: Summary of Region Fields

Region Name	Distances from antenna	Description
<b>Reactive Near Field</b>	$0 > r > \frac{\lambda}{2\pi}$	The region immediately surrounding the antenna where the reactive field (stored energy – standing waves) is dominant.
<b>Radiating Near Field</b>	$\frac{\lambda}{2\pi} > r > \lambda$	The region between the reactive near field and transition zone where the radiation fields are dominant and the field distribution is dependent on the distance from the antenna.
<b>Transition Zone</b>	$\lambda > r > 2\lambda$	The region where characteristics of both the near and far field regions can exist. The boundary is theoretical and relies upon empirical testing to determine which field type exists.
<b>Far Field</b>	$2\lambda > r$	The region farthest away from the antenna where the field distribution is essentially independent of the distance from the antenna (propagating wave).

The figure below clearly indicates all the four RF regions.

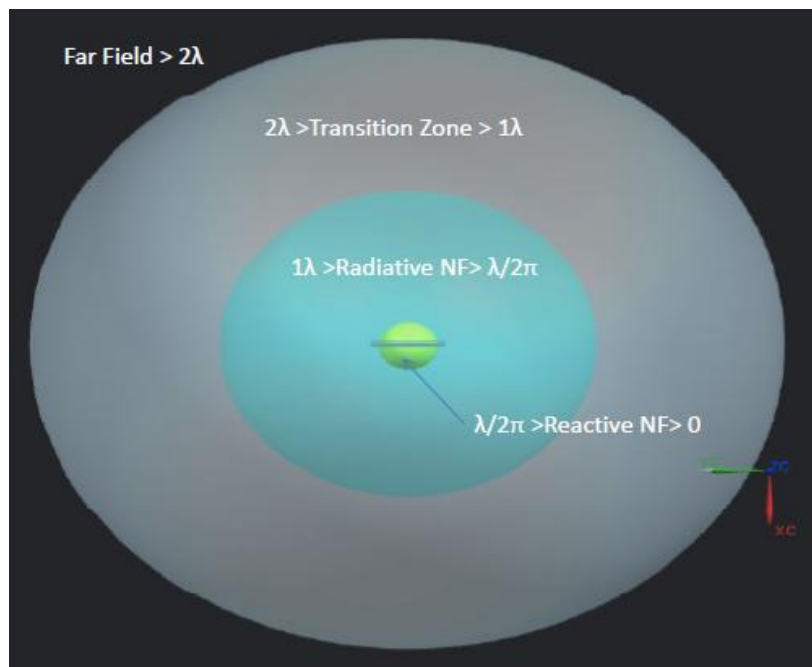
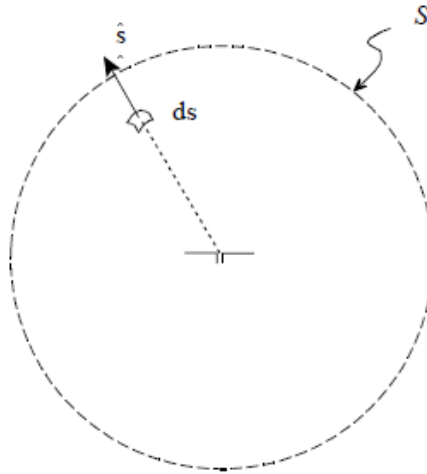


Figure 29: The four RF regions around an antenna

### 4.3 Radiating Power and Field strength (ERP and EIRP)

The isotropic antenna in the shape of a sphere creates an electric and magnetic field. The antennas are designed to emit radio waves in a particular direction. The strength is measured as Effective Radiated Power (ERP). This is different than Effective Isotropically Radiated Power (EIRP). The EIRP is the amount of power that would be emitted by an isotropic antenna to produce the peak power density observed in the direction of maximum antenna gain (i.e. intentionally direction). Maximum allowed EIRP is limited by national regulations and varies by country. (e.g. in North America it is 4 W)



**Figure 30: Surface created by antenna [63]**

A simplified formula for calculation RF field strength:

$$S = \frac{P_r}{A_{sphere}} \quad \text{Where } A_{sphere} = \pi r^2$$

**Equation 9**

By using Maxwell's equations, one could predict the effect, which a larger air gap would have on RFID tag readability.

*Gauss's Law:*

$$\int E \cdot dA = \frac{q}{\epsilon_0}$$

**Equation 10**

Treating the spherical area between the reader antenna and the tag as a Gaussian surface, as the radius  $r$  increases, the electric field  $E$  decreases. The ratio of the electric field and the magnetic field is constant, and can be defined as the speed of light  $c$ :

$$\frac{E}{B} = c$$

**Equation 11**

Since the relationship between the electric field  $E$  and the magnetic field  $B$  is considered constant, apply the decreasing magnetic field to find that it would also decrease the electromagnetic force inside of the tag.

*Faraday's Law of Induction:*

$$\varepsilon = -\frac{d}{dt} \int B \cdot dA$$

**Equation 12**

Lower power leads to higher probability that the tag circuit will not gain enough emf to reach its threshold power to activate. Therefore, increasing the read range should in theory reduce tag readability.

The power density of a hypothetical sphere of radius  $r$  can be calculated by dividing the transmitted power by the area of that sphere (Figure 28 is an example of the spherical surface created by the antenna). Below is the equation used to calculate the power density that will be seen by the tag, when the reader and tag are separated by a distance  $r$ .

$$p(r) = \frac{P_t}{4\pi r^2} \text{ Watts/m}^2$$

**Equation 13**

## 4.4 RFID units – Comparing Reader Power Outputs

RFID radiating power is an essential figure describing the performance, although it must be noted that it is not the only one. To put it simply - more power out from antenna mean that tags further away hear the reader - it is a good thing if long reading distance is the goal. But power output does not describe all aspects of the reader performance. It does not describe receiver sensitivity - from how far can a reader hear the tag, it does not describe readers speed or ability to read tags without orientation sensitivity etc.

There are two common ways to show radiating power: milliwatt (mW) and some form of decibels (dB). Complexity arises when different types of decibel figures are compared - fine if it is done correctly, but mistakes are easily done.

Decibels (dB) describe relations of two figures in logarithmic scale.

0dB:	$x=1*y$
3dB:	$x=2*y$
6dB:	$x=4*y$
10dB:	$x=10*y$
20dB:	$x=100*y$
-3dB:	$x=y/2$
-10dB:	$x=y/10$

When RFID readers power is discussed dB is not just a plain dB, but dBm, dBi etc. the part after dB describes into which the figure is compared to. For example an antenna with gain 3dBi emits to the main direction 2 times the power of an isotropic reference antenna. The "i" in dBi stands for the isotropic reference antenna.

RFID readers power output depends on 2 components. Power output going into the antenna and antenna gain. Power going into the antenna (RF power) is usually given as milliwatt (mW) or in dBm. In this case dBm describes the power compared to 1mW. In the table below the dBm to mW relation is described.

**Table 8: Relationship between dBm and mW**

dBm	Watts	dBm	Watts	dBm	Watts
0	1.0 mW	16	40 mW	32	1.6 W
1	1.3 mW	17	50 mW	33	2.0 W
2	1.6 mW	18	63 mW	34	2.5 W
3	2.0 mW	19	79 mW	35	3.2 W
4	2.5 mW	20	100 mW	36	4.0 W
5	3.2 mW	21	126 mW	37	5.0 W
6	4 mW	22	158 mW	38	6.3 W
7	5 mW	23	200 mW	39	8.0 W
8	6 mW	24	250 mW	40	10 W
9	8 mW	25	316 mW	41	13 W
10	10 mW	26	398 mW	42	16 W
11	13 mW	27	500 mW	43	20 W
12	16 mW	28	630 mW	44	25 W
13	20 mW	29	800 mW	45	32 W
14	25 mW	30	1.0 W	46	40 W
15	32 mW	31	1.3 W	47	50 W

Other component - antenna gain - is given as compared to some reference antenna.

dB<sub>i</sub> describes gain compared to isotropic reference antenna

dB<sub>d</sub> describes gain compared to reference dipole antenna

dB<sub>c</sub> describes gain compared to reference isotropic circular polarized antenna

There is a clear relation between the established reference antennas: dipole antenna radiates more to directions in 90 degree angle to the antenna dipole than ideal isotropic antenna, 0dB<sub>d</sub> = 2.14 dB<sub>i</sub>

The following equation is useful in converting from power (P) in Watts (W) and the power ratio in dBm (x):

$$P = 1W * 10^{\frac{x-30}{10}}$$

**Equation 14**

The following equation is useful in converting from power (P) in Watts (mW) and the power ratio in dBm (x):

$$P = 1mW * 10^{\frac{x}{10}}$$

**Equation 15**

## 4.5 Reader Output Powers

ERP – Effective Radiated Power

This is the power radiated by the antenna of the reader in its direction of maximum gain under specified conditions of measurement and in the absence of modulation.

ERP is calculated by multiplying the measured transmitter output power by the specified antenna system gain, relative to a half-wave dipole antenna, in its direction of maximum gain.

EIRP – Effective Isotropically Radiated Power

The amount of power that would have to be emitted by an isotropic antenna (that evenly distributes power in all directions) to produce the peak power density observed in the direction of maximum antenna gain. EIRP takes into account the losses in transmission line and connectors and the gain of the antenna.

1 W ERP = 1.64 W EIRP

ETSI regulations allow readers to transmit at 2 W ERP = 3.28 W EIRP.

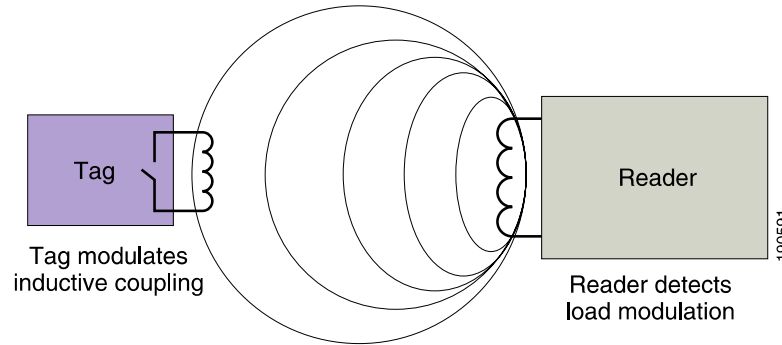
FCC regulations allow readers to transmit at 4 W EIRP = 2.44 W ERP.

US readers can transmit at higher power outputs levels than European readers (1.22 times higher (2.44 / 2)). Based on the above information, which reader has longer reading distance, a reader with 30dBm (1.0W) ERP or a reader with 32dBm (1.6W) EIRP?

## 4.6 RFID Communications Types

Passive RFID tags do not possess an onboard source of power. Instead, the passive RFID tag receives its power from the energizing electromagnetic field of an RFID reader (or interrogator). The energy coupled from the electromagnetic field undergoes rectification and voltage multiplication in order to allow it to be used to power the passive tag's microelectronics. The tag cannot communicate with host applications unless it is within the range of an RFID reader.

Passive UHF RFID systems use two types of communication or couplings: 1) inductive coupling (near field) and 2) electromagnetic coupling (far field). Both coupling types require the reader to provide a field, which the tag uses for both power and as a communication medium. In the figure below, the tag is in the field provided by the reader.



**Figure 31: Passive Tag Load Modulation [64]**

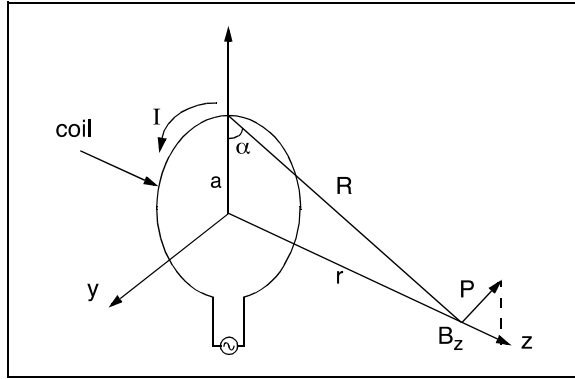
#### 4.6.1 Inductive Coupling (Near Field)

There has been much research conducted in the area of the inductive coupling [65][66] [67] [68] [69] [70] [71]. This section covers the fundamental governing equations of inductive coupling. Inductive coupling is the transfer of energy from one circuit to another via the “mutual inductance” between two circuits. RFID inductive coupling requires both the tag and the reader to have induction or “antenna” coils. The “mutual inductance” means that the antenna and tag are coupled together by a magnetic flux through both circuit’s coils. The transmission range between the tag and antenna is up to 1 wavelength (i.e. between 1 cm and 1 meter).

The RFID reader provides a short-range alternating current magnetic field that the passive RFID tag uses for both power and as a communication medium, this magnetic field induces a voltage in the antenna coil of the RFID tag, which in turn powers the tag. The tag transmits its information to the RFID reader by taking advantage of the fact that each time the tag draws energy from the RFID reader’s magnetic field, the RFID reader itself can detect a corresponding voltage drop across its antenna leads. Capitalizing on this phenomenon, the tag can communicate binary information to the reader by switching ON and OFF a load resistor to perform *load modulation*. When the tag performs load modulation, the RFID reader detects this action as amplitude modulation of the signal voltage at the reader’s antenna.

The capacitor and inductor connected together create an oscillator. Both the capacitor and inductor store energy. The capacitor stores energy in the form of an electrostatic field and the inductor stores energy in a magnetic field. The oscillator works by initially storing energy in the capacitor. Then the capacitor will start to discharge through the inductor. When this occurs a magnetic field is created.

Once the capacitor discharges, the inductor will try to keep the current in the circuit moving. This process will charge up the other plate of the capacitor and simultaneously discharge the inductor; therefore, the magnetic field collapses. This process repeats itself as long as energy is being provided to the system.



**Figure 32: Calculation of the magnetic field B at location P due to current I on the loop [68]**

Ampere’s law states that the current flowing on a conduction produces a magnetic field around the conductor. The magnetic field produced by a circular loop antenna coil with N-turns as shown in the figure below can be determined by:

$$B_z = \frac{\mu_0 I N a^2}{2(a^2 + r^2)^{3/2}} = \frac{\mu_0 I N a^2}{2 r^3} \text{ for } r^2 \gg a^2$$

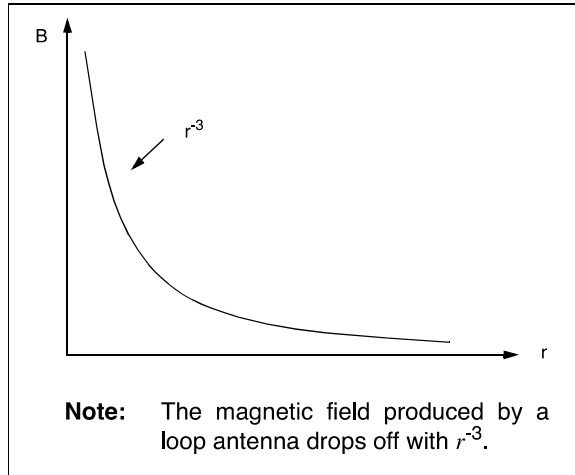
**Equation 16**

Where

- I = current
- r = distance from the center of wire
- $\mu_0$  = permeability of free space and given as  $\mu_0 = 4\pi \times 10^{-7} \text{ Henry/meter}$
- a = radius of loop

The above equation is frequently used to calculate the ampere-turn requirement for the read range. The equation indicates that the magnetic field produced by a loop antenna decays with  $\frac{1}{r^3}$ . The figure below displays the relationship between the distance, r, from the antenna and magnetic field strength, B. This near field decaying behavior of the magnetic field is the main limiting factor in the read range of the RFID device. The field strength is maximum in the plane of the loop and directly proportional to the current (I), the number of turns (N), and the surface area of the loop.





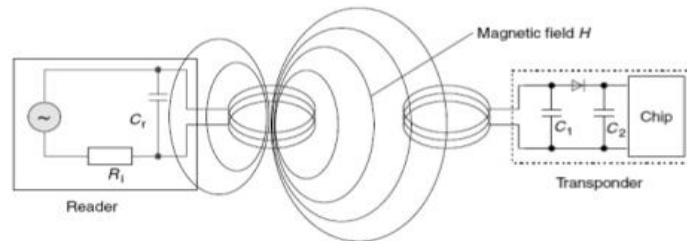
**Figure 33: Decaying of the magnetic field B vs. Distance r**

Faraday’s law is a fundamental principle for passive RFID systems. The law states that a time-varying magnetic field through a surface bounded by a close path induces a voltage around the loop. Electromagnetic induction is the production of voltage across a conduction situated in a changing magnetic flux. Faraday found that the voltage produced around closed path conduction is proportional to the rate of change of the magnetic flux through any surface bounded by that path.

$$\varepsilon = -\frac{d\phi_B}{dt} \text{ Faraday's Law for one loop}$$

**Equation 17**

When the tag and antenna are within a proximity distance, the time-varying magnetic field B that is produced by an antenna coil induces a voltage in the tag antenna coil. This is called electromotive force or simply EMF. The induced voltage in the coil causes a flow of current in the coil. This is called Faraday’s law.



**Figure 34: Magnetic Coupling between antenna and tag [67]**

When the tag is within transmission range to the antenna the antenna coil will couple to the coil of the tag. An induced voltage in the tag that is rectified and used to power the tag circuitry achieves this. All the energy used in the tag is drawn from the primary coil of the antenna.

Below is a diagram of the reader and tag are coupled together by a magnetic flux created by the reader. The induced voltage on the tag antenna coil is equal to the time rate of change of the magnetic flux  $\Psi$ .

$$V = -N \frac{d\Psi}{dt}$$

**Equation 18**

where:

- $N$  = number of turns in the antenna coil
- $\Psi$  = magnetic flux through each turn

The negative sign indicates that the induced voltage acts in such a way as to oppose the magnetic flux producing it. This is known as Lenz's Law and it emphasizes the fact that the direction of current flow in the circuit is such that the induced magnetic field produced by the induced current will oppose the original magnetic field. The magnetic flux  $\Psi$  is the total magnetic field  $B$  that is passing through the entire surface of the antenna coil.

$$\Psi = \int B \cdot dS$$

**Equation 19**

Where:

- $B$  = magnetic field
- $S$  = surface area of coil
- $\cdot$  = inner product of vectors  $B$  and surface area  $S$

The electrical current flowing through a conductor produces a magnetic field. This time-varying magnetic field is capable of producing a flow of current through another conductor. This is called inductance ( $L$ ). A coil has more inductance than a straight wire of the same material and a coil with more turns has more inductance than a coil with fewer turns. The inductance  $L$  of an inductor is defined as the ratio of the total magnetic flux linkage to the current  $I$  through the inductor:

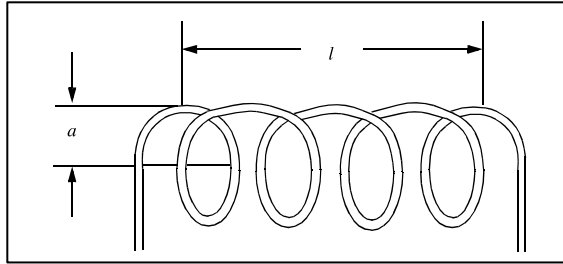
$$L = \frac{N\Psi}{I} \quad (\text{Henry})$$

**Equation 20**

where:

- $N$  = Number of turns
- $I$  = current
- $\Psi$  = magnetic flux

For a coil with antenna with multiple turns, greater inductance results with closer turns. The tag antenna coil that has to be formed in a limited space often needs a multi-layer winding to reduce the number of turns. The figure below represents a single layer coil. The actual inductance is always a combination of resistance, inductance, and capacitance.



**Figure 35: A single layer coil [68]**

The RFID system's read range greatly depends on the resonant circuit's antenna coil. The antenna coil of the tag and the capacitor form a resonant circuit that is tuned to the transmission frequency of the antenna. The voltage at the tag coil reaches a maximum due to the resonance in the circuit. The efficiency of the power transfer between the coil of antenna and the tag is proportional to:

- The operating frequency (f)
- The number of windings (n)
- The area enclosed by the tag coil (A)
- The angle of the two coils relative to each other (a)
- The distance between the two coils (d)

The resonant frequency of the circuit is determined by:

$$f_o = \frac{1}{2\pi\sqrt{LC}}$$

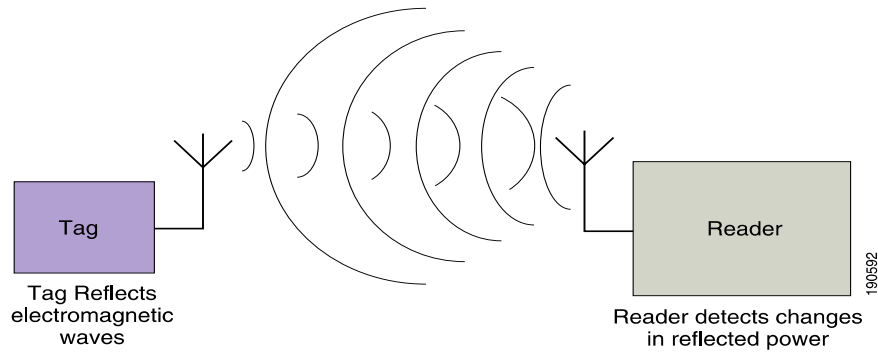
**Equation 21**

where:

- L = inductance of antenna coil
- C = tuning capacitance

#### 4.6.2 Electromagnetic Coupling (Far Field) [64]

Backscatter modulation and electromagnetic coupling in the far field occurs when the RFID reader provides a medium-range electromagnetic field that the passive RFID tag uses for both power and a communication medium. This is known as electromagnetic coupling (i.e. far field). The passive RFID tag draws energy from the electromagnetic field created by the antenna. The energy contained in the incoming electromagnetic field is partially reflected back to the RFID reader by the passive tag. The characteristics of the reflection depends on the load (resistance) connected to the antenna. The tag varies the size of the load that is placed in parallel with the antenna in order to apply amplitude modulation to the reflected electromagnetic waves. This process enables the tag to communicate information payloads back to the RFID reader via *backscatter modulation*.



**Figure 36: Passive tag backscatter modulation [64]**

Tags using backscatter modulation and electromagnetic coupling typically provide longer range than inductively coupled tags, and can be found most commonly among passive RFID tags operating at 868 MHz and higher frequencies. Far field coupled tags typically provide significantly longer range than inductively coupled tags, principally due to the much slower rate of attenuation ( $1/r^2$ ) associated with the electromagnetic far-field.

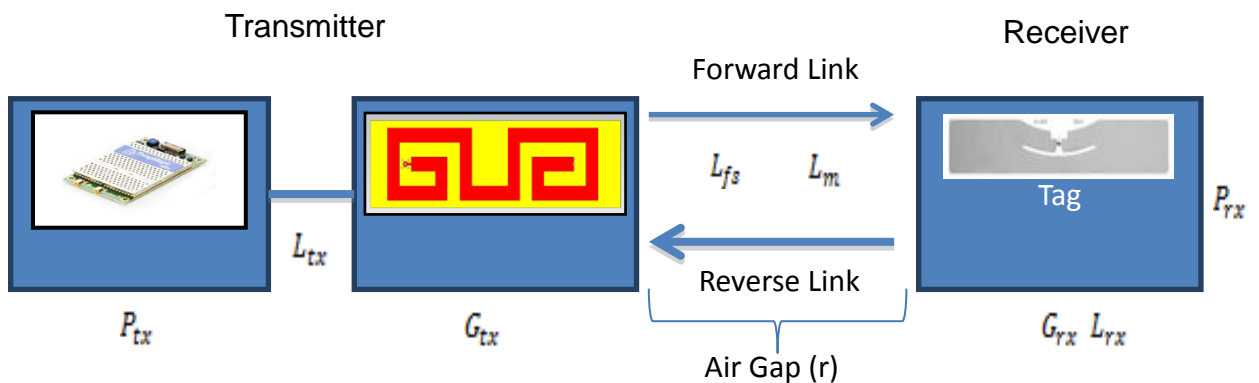
There are many variables that occur during the electromagnetic coupling. A method called the *link budget* is used to account for these variables.

#### 4.6.3 Link Budget and the Friis Equation

A link budget is a good method of engineers to calculate RFID system losses and gains in the radio connection between the antenna and tag. The link budget takes into account the antenna, tag, feed lines and the path between the antenna and tag, as well as miscellaneous gains and losses. It is important to note that the link budget is widely applied to far field applications, but it is becoming more common to near field applications. Much work has been conducted in this area [68][72][73][74][75][76][77][78] and this section covers the main governing equations and relationships.

A simple link budget equations looks like this

$$\text{Received Power (dBm)} = \text{Transmitted Power (dBm)} + \text{gains (dB)} - \text{Losses (dB)}$$



**Figure 37: Link Budget between antenna and tag**

According to the figure above

$$P_{rx} = P_{tx} + G_{tx} - L_{tx} - L_{fs} - L_m + G_{rx} - L_{rx} \quad \text{Line of sight radio link budget}$$

**Equation 22**

Symbol	Definition	Unit	Description
$P_{rx}$	Received power	dBm	Received power at the tag
$P_{tx}$	Transmitter output power	dBm	The power of signal from the radio
$G_{tx}$	Transmitter antenna gain	dBi	Add the antenna gain (isotropic gain)
$L_{tx}$	Transmitter losses (coax, connectors...)	dB	Subtract losses between radio and antenna
$L_{fs}$	Free space loss or path loss	dB	Subtract the free space of path loss between antenna and radio
$L_m$	Miscellaneous losses (fading margin, body loss, polarization mismatch, other losses, etc)	dB	Subtract the miscellaneous losses that may occur.
$G_{rx}$	Receiver antenna gain	dBi	Add the tag antenna gain
$L_{rx}$	Receiver losses (coax, connectors...)	dB	Subtract the loss between the tag and receiver circuitry

**Figure 38: Radio link budget symbols, definitions, units, and descriptions**

All factors must be represented in dBm or dBW. For example, if the transmitter puts out 10 Watts (or 10,000 mW) its power is 10,000 times the reference power of 1 mW. Since 10,000 is ten to the fourth power, this gives us a transmitted power of 40dBm. To clarify:

- 0.01 mW = -20 dBm
- 0.1 mW = -10 dBm
- 1 mW = 0 dBm
- 10 mW = 10 dBm
- 100 mW = 20 dBm
- 1000 mW = 30 dBm

Once all factors have been expressed in power levels of dBm or dBW (where 30 dBm = 0dBW and 40 dBm = 10 dBW) they gains and losses can be subtracted or added.

The available power received by the tag is governed by the Range Equation. The fundamental power relationship between the transmitter and the receiver of any communication system begins with consideration of an isotropic radiation source, which emits power equally in all directions.

The power density on a hypothetical sphere of radius r can be calculated by dividing the transmitted power by the area of that sphere.

## 4.7 Forward Link

The forward link is created when the radio and the antenna, transmitter, establishes a communication link with the tag. In order to define the forward link the following needs to be defined:

- Power available at the tag

- Power received by the tag

#### 4.7.1 Power available at the tag

The power available at the tag is directly dependent upon the antenna and is found by calculating the free space path loss between the antenna and tag. The free space path loss (FSPL) indicates the loss of signal strength of an electromagnetic wave that would result from a line of sight path through free space (i.e. air), with no imperfections. Another way to think about it is that the free space path loss is a measure of the relationship between the RF power emitted by a reader into “free space” and the RF power received by the tag.

Below is the equation with  $\lambda$  as signal wavelength (m),  $f$  as signal frequency (hertz),  $d$  as the distance between the antenna and tag, and  $c$  as the speed of light in a vacuum ( $2.99792458 \times 10^8$  m/s):

$$FSPL = \left( \frac{4\pi d}{\lambda} \right)^2$$

$$FSPL = \left( \frac{4\pi d f}{c} \right)^2$$

**Equation 23**

The free-space path loss is proportional to the square of the distance between the antenna and tag, and also proportional to the square of the frequency of radio signal. The equation is only accurate for far field region where spherical spreading can be assumed, it does not hold in the near field region.

Below is the FSPL,  $a_F$ , in log form where  $r$  is the distance between the reader and the tag, the gain  $G_T$  and  $G_R$  of the reader’s and tag’s antenna, plus the transmission frequency  $f$  of the reader:

$$a_F = -147.6 + 20 \log(r) + 20 \log(f) - 10 \log(G_T) - 10 \log(G_R)$$

**Equation 24**

#### 4.7.2 Power received or absorbed by the tag

This is the power received or absorbed by the RFID tag,  $P_R$ , and is defined by applying the Friis EM wave propagation equation in free space. The tag antenna intercepts only a portion of the transmitted power depending upon the effective area  $A_e$  of that antenna. The received power is given by,

$$P_r = p(r)A_e = \frac{P_t A_e}{4\pi r^2} \text{ Watts}$$

**Equation 25**

The equation gives the maximum power available at the tag, given an isotropic radiator and an effective area of the tag antenna. The FCC always specifies limits on radiation based on an EIRP

(see section 4.3). In North America the EIRP limit for UHF RFID is 4 Watts. The transmitted power  $P_t$  in the Power Density equation can be replaced by the EIRP:

$$P_t = EIRP$$

$$P_r = EIRP \frac{A_e}{4\pi r^2} \text{ Watts}$$

**Equation 26**

The relationship between the tag antenna gain  $G_r$  and the tag antenna effective area is

$$G_r = \frac{4\pi A_e}{\lambda^2}$$

**Equation 27**

where  $\lambda = c / f$  is the free space wavelength,  $c$  is the speed of light, and  $f$  is the operating frequency. Replacing  $A_e$  in the transmitted power equation from the previous equation the final expression for the available power at the tag due to a given transmitted EIRP is

$$P_r = \frac{EIRP G_r \lambda^2}{(4\pi r)^2} \text{ Watts}$$

**Equation 28**

This is called the Friis equation. The next equation is the Friis equation is an alternative form:

$$P_R(r) = \left(\frac{\lambda}{4\pi r}\right)^2 P_T G_T G_R \text{ Watts}$$

**Equation 29**

Where

- $\lambda$  = The wavelength in free space
- $r$  = The operational distance between an RFID tag and the reader (read range)
- $P_T$  = The signal power feeding into the antenna by the transmitter
- $G_R$  = The gain of the reader antenna
- $G_T$  = The gain of the tag antenna

Another common form of the Friis equation is below. It is in units of dB.

$$P_r = P_t + G_t + G_r + 20 \log_{10} \left( \frac{\lambda}{4\pi r} \right)$$

(Gain has units of dB, and power has units of dBm or dBW)

**Equation 30**

The simple form applies only under the following conditions:

- $R \gg \lambda$ , which implies that the distance between the antenna and tag,  $R$ , is much greater than the wavelength,  $\lambda$ . Note that if  $R < \lambda$  would imply that the received power is greater than the transmitted power. This is a violation of the law of conservation of energy.
- The antennas are in unobstructed free space, with no multipath.
- $P_r$  is understood to be the available power at the receiver antenna terminals. There is a loss introduced by both the cable running to the antenna and the connectors. Note that the power of the output of the antenna will only be fully delivered into the transmission line if the antenna and transmission line are conjugate matched (i.e. impedance matched).
- $P_t$  is understood to be the power delivered to the transmit antenna. There is loss introduced by the cable running to the antenna and the connectors. Note that the power at the input of the antenna will only be fully delivered into freespace if the antenna and transmission line are conjugated matched (i.e. impedance matched)
- The antennas are correctly aligned and polarized.
- The bandwidth is narrow enough that a single value for the wavelength can be assumed.

### Example Calculation

A tag antenna is often a variation of a dipole. A classic half- wave (length =  $\lambda/2$ ) dipole has a gain  $G = 1.64$ . Using  $EIRP = 4W$ ,  $G_T = 1.64$ ,  $r = 10$  m, and  $f = 950$  MHz in equation results in a receive power  $P_r = 41.4 \mu\text{Watts}$ . Clearly, the tag design must have extremely low threshold.

$$P_r = \frac{(4 \text{ watts})(1.64)\left(\frac{\lambda}{2}\right)^2}{(4\pi r)^2} = 41.4 \mu\text{Watts}$$

**Equation 31**

## **4.8 Power Absorbed by the tag IC**

The tag absorbs the power through its antenna and transfers it to the IC. This is how the data is accessed in the tag and transferred back to the reader.

### **Power absorbed by the tag IC**

$$P_{abs} = P_{inc} p G_r \tau_r$$

**Equation 32**

$P_{abs}$  = Power absorbed by tag

$p$  = polarization efficeincy (i. e. loss factor)

$G_r$  = Gain of antenna

$\tau_r$  = tag impedance matching coefficient

#### **4.8.1 Factors Limiting Range**

The equation from above only indicates the power available to the tag antenna. The actual power accepted by the tag circuit could be significantly less, depending upon several loss mechanisms, including antenna mismatch, polarization mismatch, antenna misalignment, and environmental scattering. Any number of loss mechanisms can be added to (2.5) by multiplying by loss factors



ranging from 0 to 1. For example, we can include a polarization loss factor  $p$ , where  $0 \leq p \leq 1$  and an antenna mismatch factor  $\tau$ , where  $0 \leq \tau \leq 1$ .

$$P_{r(effective)} = \frac{EIRP G_r \lambda^2 p \tau}{(4\pi r)^2} \text{ Watts}$$

**Equation 33**

$p$  is the polarization efficiency (also called polarization loss factor)  $\tau$  is the mismatch factor and is defined by

$$\tau = \frac{(R_c R_a)}{|Z_c + Z_a|^2}$$

**Equation 34**

where  $Z_c = R_c + jX_c$  is the tag chip input impedance and  $Z_a = R_a + jX_a$  is the tag antenna impedance. These equations can be used to compute the power available at the antenna terminals, given the transmit EIRP and the range. As mentioned earlier, the tag can only begin operation once the input power has exceeded a certain threshold  $P_{th}$ . Rearranging  $P_r$  from above allows us to compute the range  $r$  in terms of the other parameters including the threshold power and the signal wavelength  $\lambda$ :

$$r = \frac{\lambda}{4\pi} \sqrt{\frac{EIRP G_r \tau p}{P_{th}}} \text{ meters}$$

**Equation 35**

For example, using the previous values plus a chip threshold power  $P_{th} = 10\mu\text{W}$ , a mismatch factor of 0.5, and polarization loss factor of 0.5, yields to a range  $r = 10$  m.

#### 4.8.2 Reverse link

The reverse link starts when the tag reflects data back to the reader by phenomenon referred to as backscattering. The reflected signal from the tag is a function of the power reflected back to the reader.

Much research has been conducted in the area of the modulated backscatter [79][80][81][82][83][84][85][86]. This section will cover the fundamental governing equations of modulated backscatter. Modulated backscatter coupling in RFID systems works similar to radars, in which the antenna provides the radio frequency signal for communication in both directions. The tag itself does not have a power source, but rather uses the impinging (incident) power from the antenna on which to modulate its response. The modulated backscatter coupling works beyond the near field starting approximately between  $\frac{\lambda}{2\pi}$  and 2 wavelengths. The power decreases by one-quarter as the distance doubles.

Depending on the properties, an antenna reflects part of an incoming electromagnetic wave back to the sender. The efficiency of reflection is particularly large for antennas that are in resonance

with the incoming waves. The short wavelengths of UHF facilitate the construction of antennas with smaller dimensions and greater efficiency.

### **Backscattered power**

The backscatter power from the tag to the antenna is defined by

$$P_{bs} = P_r K$$

**Equation 36**

$P_{bs}$  = Backscatter power

$P_r$  = Power absorbed by the tag

$K$  = backscatter gain (Negative number)

### **Received power of tag signal at the reader**

The power received tag signal at the reader is defined by:

$$P_r = P_{bs} G_{path} \rho G_r \tau_r$$

**Equation 37**

#### **4.8.3 Link Budgets limiting factors**

In RFID systems, the forward link is limited by the tag sensitivity  $P_{tag}$  while the return link is limited by the reader sensitivity  $P_{reader}$ . When the incident power  $P_r$  is larger than the tag sensitivity (or, equivalently, when the absorbed power  $P_{abs}$  is larger than the tag chip sensitivity  $P_{chip}$ ), the tag is powered and responding. The reader can decode the tag response when the tag signal power  $P_r$  received at the reader is larger than the reader sensitivity.

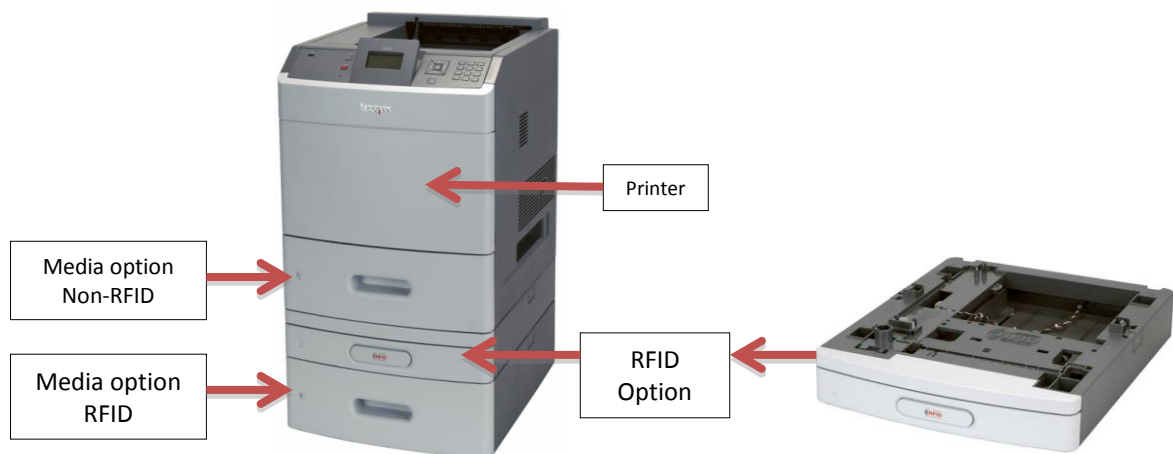
The reader sensitivity is the minimum power of the received tag signal required for successful decoding and is primarily defined by the level of self-jammer (the signal from the reader transmitter that couples into the reader receiver) which itself depends on transmitted power and receiver isolation. In general, the stronger is the self-jammer; the worse is the reader sensitivity.

## 5 Lexmark T654 RFID UHF Option

The RFID UHF option is a RFID (EPC Global Class 1, Generation 2 tag, - ISO 18000-6C) programming device for the T654 laser printer. Integrating the RFID option with the printer allows for both printing human readable information and RFID tag programming to be carried out simultaneously. The system is unique because it can print, program and verify the tag on media ranging in size from 5" x 7" inches up to 8.5" x 14" inches (legal-size).

The RFID option contains the critical RFID components, radio and antenna, that allows for tag programming. The T654x printer is a vertically stacked system. The printer is stacked in the following order: printer, non-RFID media option, RFID option, RFID media option (figure 39). This type of configuration supports multiple types of media, such as vinyl, integrated labels, plain paper or card stock.

The design intent of the RFID option is to easily upgrade NON-RFID printers. The RFID option is added below the printer (see figure 39). This also requires another media option to be located below the RFID option. This is for staging non-programmed RFID enabled media.



**Figure 39: Lexmark T654x laser printer and option**

The tag can be located on either the printed or non-printed side of the media. It is recommended that the tag is located on the non-printed side for optimal performance. The tag can be located within a large area of the media sheet and be oriented either parallel or perpendicular to the reader antenna.

### 5.1 System Paper Path

The system paper path is important for performance of the transport of RFID media. The layout describes the path from two different sources, singles and duplex jobs, and two different output paths.

- 1a) Main printer input option tray –The tray is located above the RFID option; therefore, this is designed for non-RFID media only.

- 1b) Added media input options – three extra input options can be added below the main printer. This includes the RFID media.
- 2) Imaging Unit - The image is applied to the media and is referred to as the EP (electro photo) process. The toner is unfused until it reaches the fuser.
- 3) Fuser – The image is fused to the media by melting toner (operating temperatures can reach up to 400F).
- 4 and 5) Simplex / Duplex Diverter –
- Simplex – Single side printing. The simplex page travels from the input option straight to the output option.
  - Duplex - double side printing. The duplex page must travel twice through the imaging unit (EP process) and fuser. In order to accomplish the page re-enters the system paper path. The transition from the simplex to the duplex side the page must change directions. This is accomplished by allowing the simplex page to “peek-a-boo) outside the machine at (7) , then reverse directions back into the machine. The duplex path is shown below by (4) and (5). The duplex page reenters the original path located at the front of the machine and the printing process begins.
- 6) Output Option Path – Additional output options can be applied to the top of the machine. This allows jobs to be easily separated.
- 7) Output Tray – The output tray is located in the printer and where finished jobs exit the system paper path.

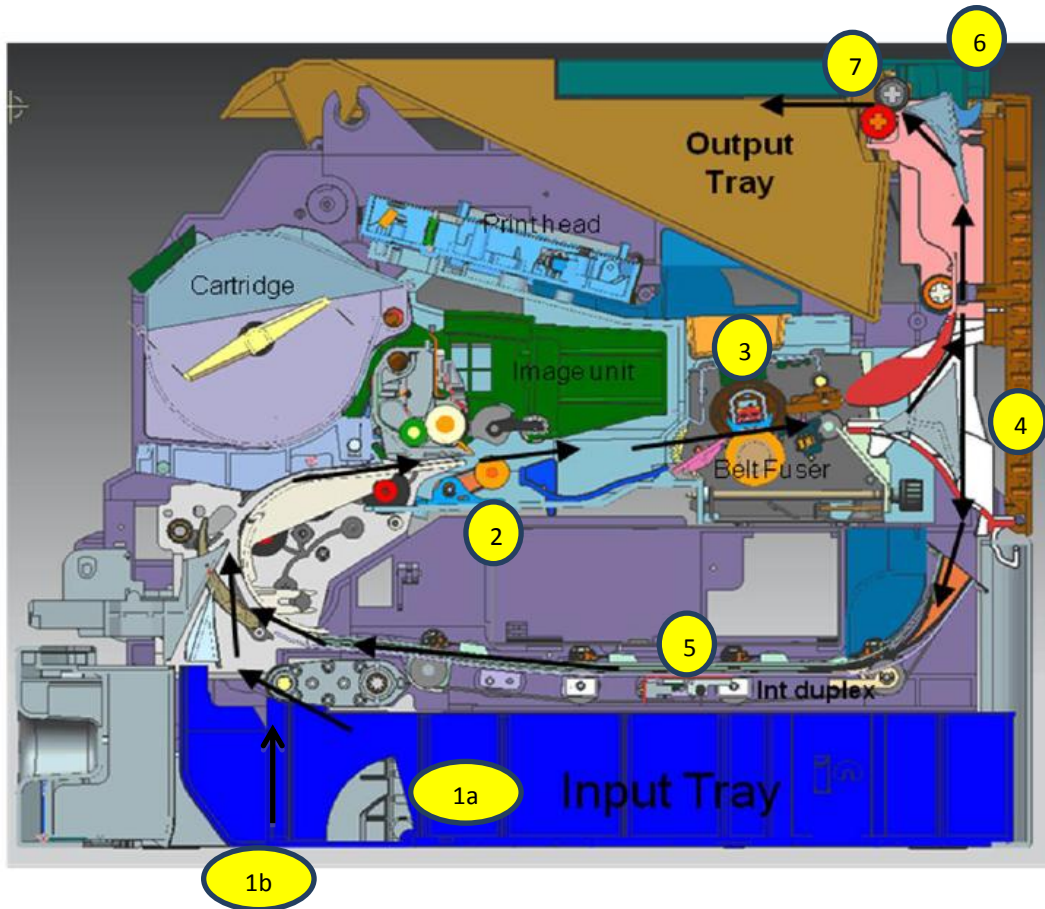


Figure 40: System paper path layout

## 5.2 Antenna Location with respect to the paper path

The Meander antenna is a far field antenna that is designed to operate in the near field regions. In other words, it is a bad antenna for “far” distances and good antenna for “near” distances. The purpose of the Meander antenna was to program tags across the max width piece of paper (215 mm). Figure 41 has a graphic of the RFID input tray (left) and a cross section of the tray (right). The cross section is a layout of the paper with the embedded tag with respect to the antenna. The paper path and antenna is separated at a distance of approximately 48.5 mm.

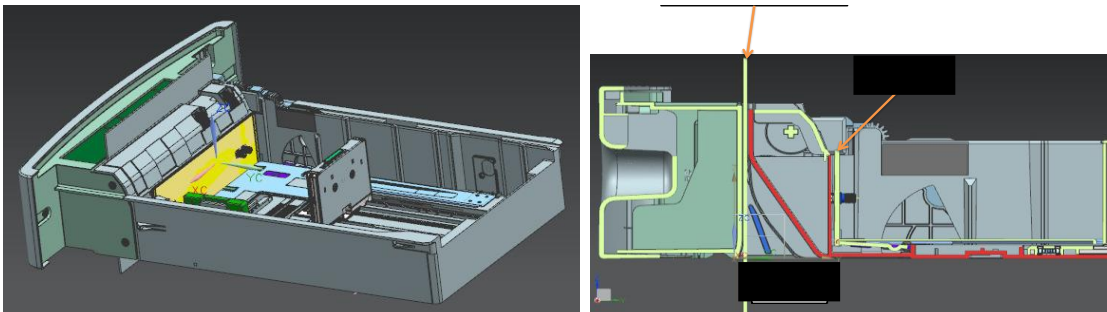


Figure 41: RFID Input Option - Houses RFID hardware components

Figure 42 is a top view of the RFID option with all required components removed except for the antenna. The red line below represents the paper location and the yellow thin rectangle is the antenna. Due to design constraints, the closest possible position was chosen for the antenna to the media path (i.e. 48.5 mm).



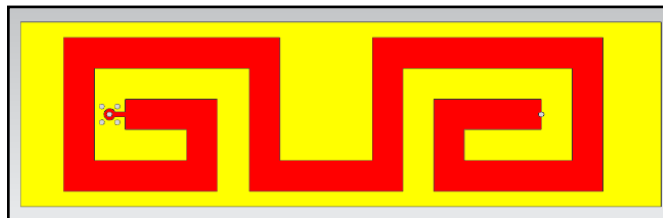
**Figure 42: Top view of the Meander Antenna (yellow line) location with respect to the paper path (red line)**

The position of the antenna is located on the boundary for the reactive and radiative near field regions. This is interesting because the antenna is designed to be a far field antenna that operates in the near field region. It is not known the programming differences between each of the near field regions. It is also not known which near field region type in which the antenna operates in. This location is of interest and brings up research questions such as:

- Can the tag programming be predictable and reliable?
- Which type of antenna is optimal for this location (near field or far field)?
- Which type of tag is optimal for this location?

### 5.2.1 Meander Antenna

The Meander antenna is polarized, meaning that RFID tags can be programmed in two specific directions: 1) tag and antenna are parallel with respect to each other and 2) tag and antenna are perpendicular with respect to each other. Programming error dramatically increases when the tag and antenna are not parallel or perpendicular with respect to each other.



**Figure 43: Meander Antenna: A far field antenna that is designed to operate in near field ranged**

The back of the antenna is layered with copper and is critical for programming. When assembled, the antenna is located against an aluminum layer as the ground plane. The copper backing and

alumina layer are essential to tag programming because it affects the field of strength created by the antenna.

If the surface area of either the copper or antenna is insufficient, programming holes are created across the antenna. Programming holes are spaces where tags cannot be programmed due to insufficient field strength.

The antenna is called the Meander, named after the antenna pattern. It is a far field antenna that is designed to operate in near field ranges; therefore, only far field RFID tags can be reliably programmed. The antenna pattern can be found in figure 44. The red line is the actual antenna used for programming.

### 5.3 Reader – ThingMagic 5e

The Lexmark solution uses an embedded Mercury 5e reader from ThingMagic [87]. The reader was selected because the design intent is for applications that require UHF tags to be programmed while moving. It has a maximum tag read rate of over 200 tags per second and has a maximum tag read distance of over 30 feet (9 m) with 6 dBiL antenna (36 dBm EIRP). Writing specs are not available from the manufacturer and were determined through empirical testing, which will be discussed later in Chapter 7.



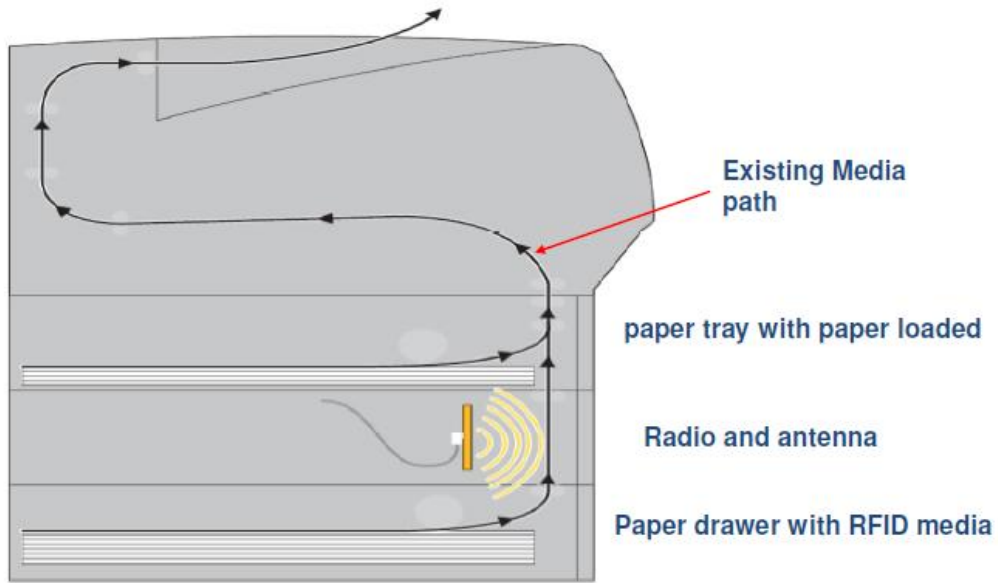
Figure 44: ThingMagic 5e Reader [87]

### 5.4 Programming Windows

A portion of the media path is also located in the RFID option, allowing media to pass through. The programming window is the time the tag spends in the RF field created by the antenna. The tag programming operation is completed while the media is in the programming window. The tag programming operation consists of three main parts: read – write – verify

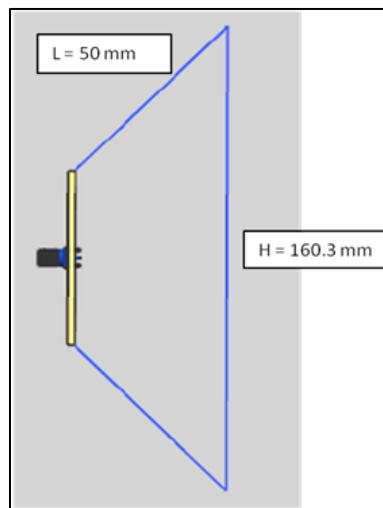
1. Read: read the tag to identify a tag is in the field to be programmed
2. Write: programming the tag with information
3. Verify: read the tag to verify the data was programmed correctly

The critical paper path section is located between the paper drawer with RFID media (bottom) and the paper tray with non RFID paper (first drawer under printer, figure 45).



**Figure 45: Printer cross section - simple paper path**

Figure 46 is a zoomed in picture of the calculated programming window based on radio wave angles. This calculation is theoretical and was verified. This is discussed in the research found in the upcoming chapters. The critical paper path section is found in the middle tray that houses the radio and antenna hardware.



**Figure 46: Programming window**

Figure 46 depicts the programming window. The L is the distance the media path is from the antenna and the H is the media path is in the RF field.

Letter size RFID labels can be printed up to 20 pages / minute. This translates to 3.7 inches / second. The conversion from pages per minute to inches per second is:



$$20 \frac{\text{pages}}{\text{minute}} \times \frac{11 \text{ inches}}{1 \text{ page}} \times \frac{1 \text{ minute}}{60 \text{ seconds}} = 3.7 \text{ inches / second}$$

**Equation 38**

The time the tag is in the programming window is defined by dividing the media path length by the tag velocity (defined above).

$$\frac{\text{Media path length}}{\text{Tag velocity}} = \frac{160.3 \text{ mm}}{93.98 \frac{\text{mm}}{\text{sec}}} = 1.7 \text{ seconds}$$

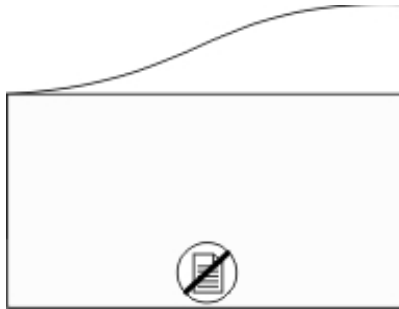
**Equation 39**

It is worth noting that the programming window length is calculated by assuming the angle at which the field is created and optimal is at 45 degrees.

## 5.5 Identifying Rejected RFID labels

A rejected RFID label is marked with two different symbols. A “X” is printed on top the tag and second symbol is printed at the bottom of the page (see Figure 47). Pages that fail the verification stage are marked and separated into a designated media output bin. This is to help ensure that the rejected labels are not used. When this event occurs, the job is reprinted and reprogrammed.

The rejected label symbol is not sufficient in preventing the rejected tag from being implemented into the larger RFID system. This reason is because the tag can be removed from the label. The rejected label symbol could not be seen and the rejected tag would be identified as a good tag. The printed “X” located on the tag provides a secondary visual to help ensure the rejected tag is not used.



**Figure 47: Rejected Label Symbol [88]**

There is a “Stop on Fail” command that does not rely on printed images. The printer will stop when a rejected label occurs. This is a third fail safe that require the user to take action and remove the rejected label before continuing.

### 5.5.1 Defining the Four RF Regions created around the antenna

As discussed in section 3.2.3 Field Regions, there are four different regions created around the antenna. The method the antenna communicates with the tag depends which region the tag is located. The regions are based on the radial distance the tags are located from the antenna.

The regions are defined by the wavelength of the UHF frequency bandwidth as 860 MHz to 960 MHz. The wavelength can be defined as the speed of light divided by the frequency in hertz (or 1/s).

$$\lambda = \frac{c}{f}$$

**Equation 40**

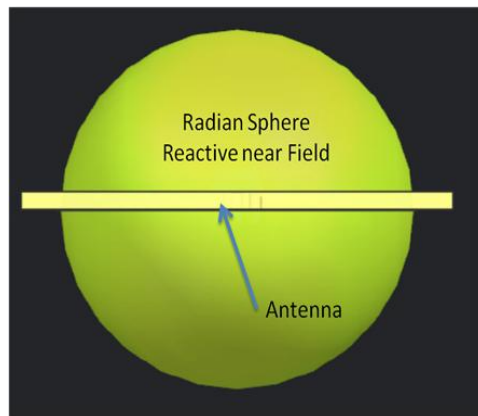
$$\lambda = \frac{3 \times 10^8 \frac{m}{s}}{860 \times 10^6 \frac{1}{s}} = 0.348 \text{ m to } \lambda = \frac{3 \times 10^8 \frac{m}{s}}{960 \times 10^6 \frac{1}{s}} = 0.312 \text{ m}$$

The wavelength range is 0.312 m to 0.348 m. The distance the reactive near-field regions ends and the radiative near field regions starts is defined by the wavelength divided by  $2\pi$ . This distance is measured from the antenna (i.e. source).

$$r = \frac{\lambda}{2\pi}$$

**Equation 41**

$$r = \frac{0.348 \text{ m}}{2\pi} = 0.055 \text{ m to } r = \frac{0.312 \text{ m}}{2\pi} = 0.049 \text{ m}$$



**Figure 48: Radian sphere created around the near field antenna**

The boundary between the reactive and radiative near field regions is located between 49 mm and 55 mm from the antenna. See Figure 14 for a representation the radian sphere centered around the near field antenna.

The boundary between the radiative near field and the transition zone is determined by one wavelength of the UHF frequency, which was calculated earlier.

$$r = \lambda = 0.312 \text{ to } 0.348 \text{ m}$$

**Equation 42**

The boundary between the transition zone and far field regions is determined by two wavelengths of the UHF frequency. The boundary is located between 0.624 to 0.396 m.

$$r = 2\lambda = 0.624 \text{ to } 0.696 \text{ m}$$

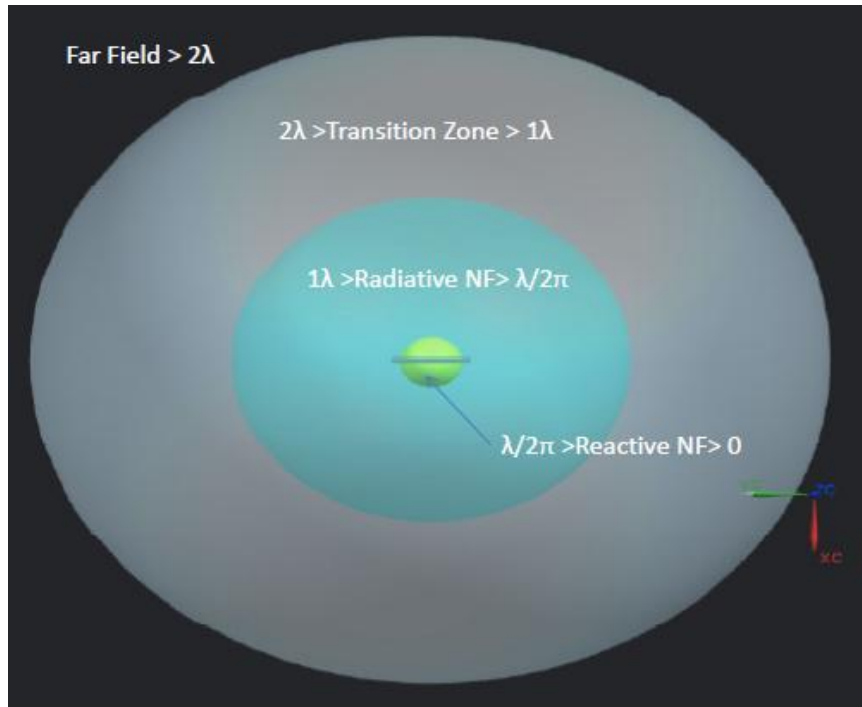
**Equation 43**

A summary of the four regions boundaries are listed below. The wavelengths are based upon 0.332 m and 0.348 m (using the UHF frequency).

**Table 9: Summary of field regions and their locations**

<b>Region</b>	<b>Boundary Definition</b>	<b>Boundary Definition</b>
<b>Near Field - Reactive</b>	$0 > r > \frac{\lambda}{2\pi}$	0 to 49 – 55 mm
<b>Near Field - Radiative</b>	$\frac{\lambda}{2\pi} > r > \lambda$	49 – 55 mm to 312 – 348 mm
<b>Transition Zone</b>	$\lambda > r > 2\lambda$	312-348 mm to 624 – 696 mm
<b>Far Field</b>	$2\lambda > r$	624-696 mm to infinity

Figure 49 represents all four field regions based upon on the boundary definitions calculated above centered about the antenna. This figure clearly shows how small the radius of the reactive near field is around the antenna.



**Figure 49: The four RF regions centered around the antenna**

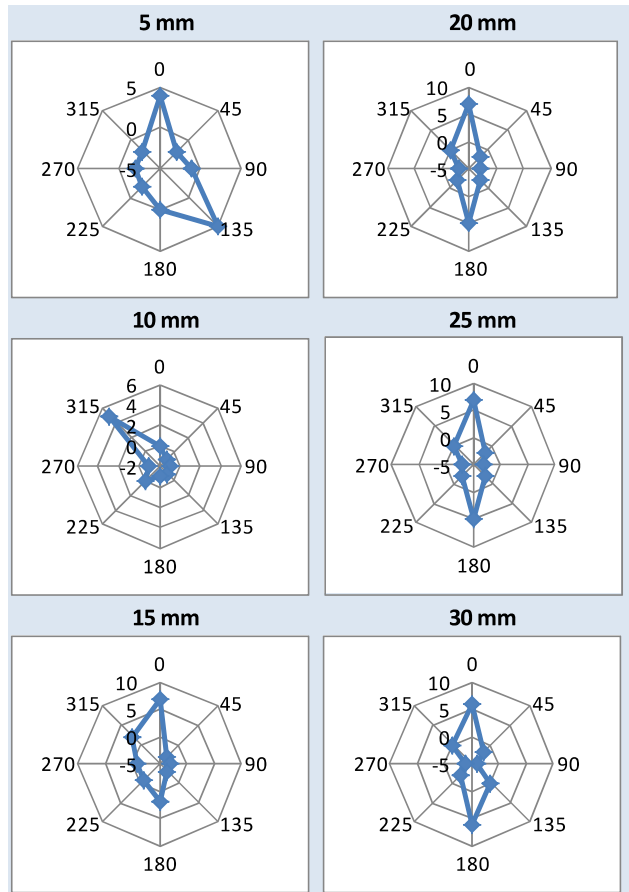
## 5.6 Previous Research

Previous research in this area has been conducted with a focus on tag rear-error rate profiles [89]. The work aided in laying the groundwork on tag behavior in a passive UHF RFID dynamic system. More specifically, the research investigated the critical read variables with two different antennas and over 15 different tag types. The end results indicated that each tag had a unique rear-error rate pattern and they all could be identified into the following 5 profile subsections:

- Isotropic Error Profile
  - UPM Button
  - UPM Paperclip
  - UPM Web
  - Alien ALN 9534 “2 x 2”
  - Avery Dennison AD805
- Dipole Error Profile
  - UPM Raflatac Dogbone
  - Alien ALN-9540 “Squiggle”
  - Avery Dennison AD 223
  - Rafsec “Short Dipole”
  - Alien ALN-9640 “Squiggle”
- Monopole Skew Error Profile
  - Alien ALN 9662 “Short”
- Patch Error Profile
  - Alien ALN-9654 “G”

- - ALN 1800073-001 "M"
  - UPM Raflatac Hammer
- Hybrid Error Profile
  - UPM Satellite

Each of the following tags was tested at different air gaps, tag orientations, reader power levels and antenna types. Below are examples of typical polar plots of read-error rates significance at Different Orientations (UPM Raflatac Dogbone, Loop System) [89].



**Figure 50: Typical Polar Plots of Read-Error Rates Significance at Different Orientations (UPM Raflatac Dogbone, Loop System) [89]**

## 6 Printer Programming Simulation

The purpose of the experiments performed in this chapter is to identify the combinations of variables to achieve an optimal tag programming response in a dynamic passive UHF system. The research conducted can be applied to similar passive UHF RFID dynamic systems. These types of systems can be found in multiple industries (e.g Figure 22: Mobility – RFID conveyer applications). However, the research in this thesis focuses on the Lexmark T654 RFID solution (see chapter 5 for more detailed information).

The scope of this investigation in this section of the paper path is where the media with the embedded RFID tag passes through the programming field created by the antenna (Figure 41, RFID media passing through the RFID hardware option). This is referred to as the *programming path*. A test fixture, LexSlide1, was created to decouple the non-programming and programming variables.

### 6.1 Design Intent

The design intent of LexSlide1 had three pillars:

- Simulation
  - Simulate the programming path in the T654 RFID solution
- Interchangeable programming hardware components (Includes both near and far field)
  - Reader
  - Antenna
  - Tag
- Adjustable programming variables
  - Air gap
  - Reader power levels
  - Tag orientating
  - Linear speed

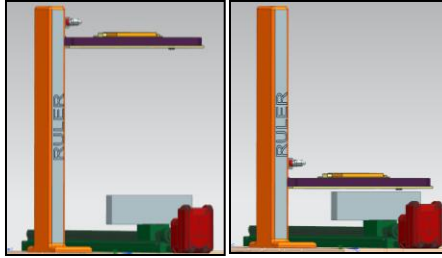
### 6.2 Programming Variables

#### 6.2.1 Air Gap

The air gap is defined as the unobstructed distance between the antenna and the reader. The Lexslide1 fixture has an air gap range from 0-250 mm. Figure 57 shows the difference between a large air gap (right) and minimal air gap (left).

Recall the four RF regions defined in section 5.3.1, the LexSlide1 has the capability to test the reactive- near field and radiative near field regions (also see table 5 for a list of each RF region and their boundaries). The LexSlide1 requires additional modifications for transition zone and far field testing.

Figure 51 shows the antenna set at the highest air gap setting (250 mm – on left) and the antenna set at the lowest air gap setting (5 mm – on right). The antenna can be set at any position between the two positions.



**Figure 51: Large air gap (left) and small air gap (right)**

### 6.2.2 Reader Power Level

The ThingMagic Mercury 5e reader has a power level range between 5 dBm and 30 dBm [70]. Power levels in the research were divided into 5 settings: 10 dBm, 14.2 dBm, 18.5 dBm, 22.8 dBm, 27 dBm. The table below used equations 14 and 15 (discussed in section 4.4) to convert the power to W and mW.

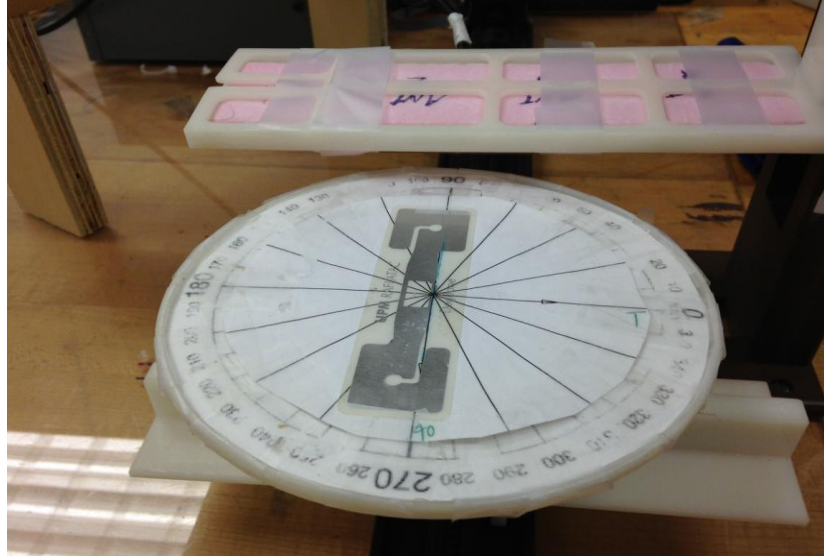
**Table 10: LexSlide1 reader power level conversions between dBm, W and mW**

Decibel milliwatts (dBm)	Watts (W)	milliWatts (mW)
10	0.01	10
14.2	.026303	26.30268
18.5	.070795	70.79458
22.8	.190546	190.5461
27	.501187	501.1872

### 6.2.3 Tag Orientation

Tag orientation is with respect to the reader. The IC of the tag is aligned to the antenna center and is rotated about this point. The main tag orientation angles were divided into 8 angles every 45° from 0° to 360°. Below are the 8 angles the in which testing was conducted.

- 0°, 45°, 90°, 135°, 180°, 225°, 270°, 315°



**Figure 52: Tag in 0° orientation with respect to the antenna**

### 6.2.4 Linear Velocity

Linear velocity is the velocity in which the tag travels with respect to the static antenna. A stepper motor is attached to the linear slide for controlling the linear velocity. The velocity is measured in centimeters per second (i.e. cm/s). This is calculated by the following equation

$$N \frac{\text{pages}}{\text{minute}} \times \frac{11 \text{ inches}}{1 \text{ page}} \times \frac{1 \text{ minute}}{60 \text{ seconds}} \times \frac{2.54 \text{ centimeter}}{1 \text{ inch}} = \frac{\text{centimeter}}{\text{second}} = (\text{cm/s})$$

**Equation 44**

Five linear velocities were tested on the LexSlide1: 9, 18, 22, 27, and 31 cm/s. The table below has the conversion between pages per minute (ppm), inches per second (ips), centimeters per second (cm/s), and millimeters per second (mm/s):

**Table 11: Linear velocity conversions between ppm, ips, cm/s, and mm/s**

ppm	ips	cm/s	mm/s
19.3	3.5	9	90
38.6	7.1	18	180
47.2	8.7	22	220
57.9	10.6	27	270

### 6.3 LexSlide1 Test Fixture

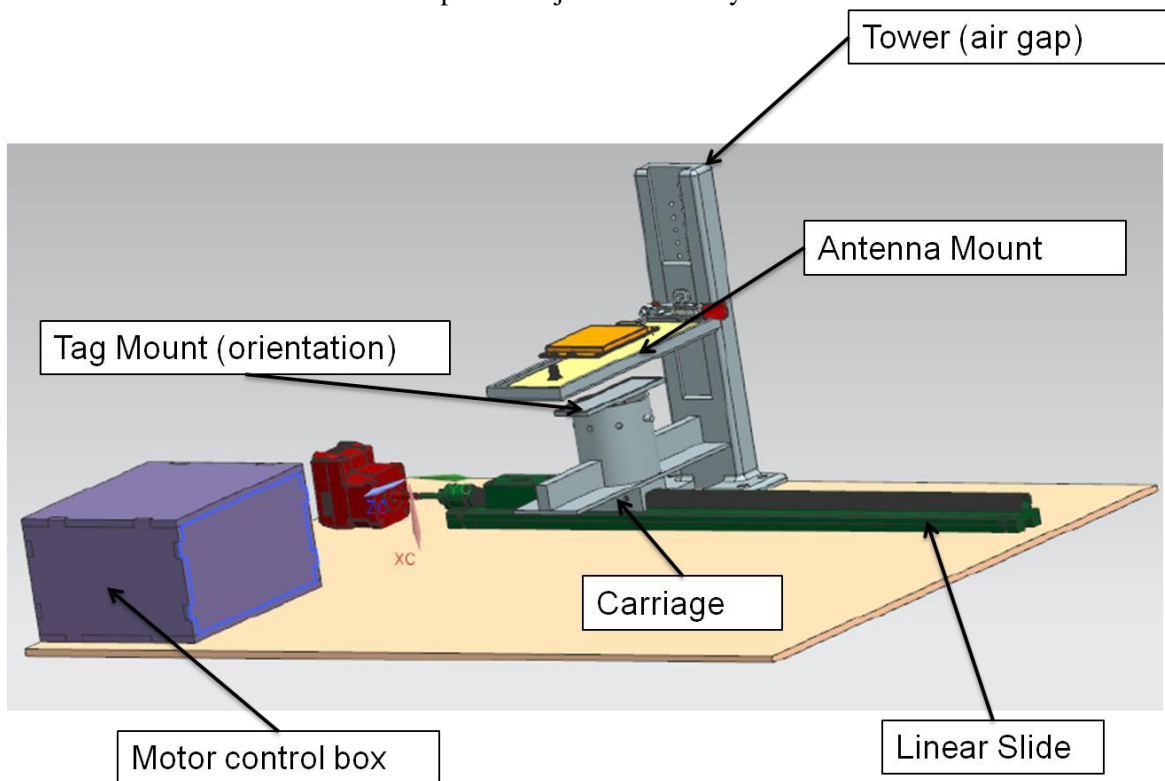
The design intent for the LexSlide1 test fixture is to simulate the programming of RFID media as it passes through the RFID Lexmark option. This is discussed in more detail in section 5.4 “Programming Window”. The main value add the LexSlide1 offers is flexibility for interchangeable programming components. The next two sections describe the infrastructure and the interchangeable programming components.



### 6.3.1 Infrastructure

The LexSlide1 test fixture consists of six main components. They are as follows:

- Linear Slide – The linear slide is driven by a motor and carries the tag in a linear direction. The linear slide represents the RFID media with an embedded tag traveling through the RFID hardware option in the printer system.
- Motor Control Box – The Motor Control Box houses all electronics required for operating the liner slide and antenna. This includes the reader.
- Carriage – The Carriage is attached to the linear slide. The Tag Mount is attached to the top of the Carriage.
- Tag Mount –The Tag Mount is a three-piece assembly. It has 2 degrees of freedom. The Tag Mount can slide laterally for tag alignment to the antenna and can rotate for tag orientation with respect to the antenna.
- Antenna Mount – The Antenna Mount holds the antenna. It is attached to the Tower and cantilevers over the linear slide. It can translate vertically to allow the Air Gap to be adjusted.
- Tower – The Tower is a static part mounted to the fixture plate. It holds the Antenna Mount and allows the Air Gap to be adjusted vertically.



**Figure 53: LexSlide1 Main Components**

### 6.3.2 Interchangeable Components

The LexSlide1 allows the critical programming components to be interchangeable. This includes the reader, antenna, and tag. All interchangeable components are easy to change, in that they do not require tools. It is important to note that firmware changes are required when the reader is interchanged.

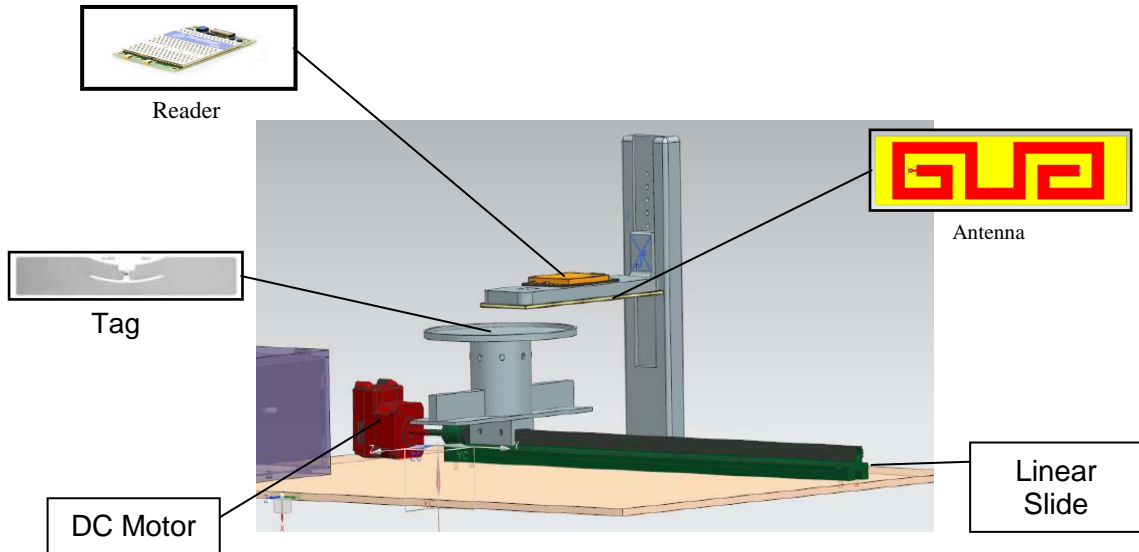


Figure 54: LexSlide1 test fixture

## 6.4 Software and the Graphical User Interface (GUI)

Internal software programs were developed to control both the linear slide stepper motor and the RFID reader. C# was used to create the software and the graphical user interface (GUI) used for this research. The following are the operations the GUI allows the user to perform and their descriptions.

- Turn on/off antennas – A total of four antennas can be tested simultaneously. All testing conducted in this thesis only required one antenna. The GUI allowed the user to turn on the desired antenna port and turn off all others. The figure below shows that antenna port 1 is on (green) and the other antenna ports are off (red).

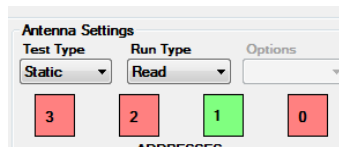


Figure 55: GUI - Antenna on / off control

- Test Type - There are three test types that can be selected: static, static offset, and dynamic. They are in the drop down menu found in “Test Type”.

- Read / Write – Test can be conducted as read or write tests. This is selected in the drop down menu under “Run Type”. When a write test is being conducted the tag memory address and block programming data must be provided.
- Reader Power levels – The “reader start power” and the “reader stop power” are used to set the reader power limits. The “Reader Power Stops” define the power levels to be tested. When a test is executed all power level stops are tested. The figure below has the reader power starting at 10 dB and stopping at 27 dBm. The total number of 5 tests are executed at 4.25 increments: 10 dB, 14.2 dBm, 18.5 dBm 22.8 dBm and 27 dBm.

Reader Start Power dBm:	10
Reader Stop Power dBm:	27
Reader Power Steps dBm:	4.25

**Figure 56: GUI - Reader power level control**

- Test attempts – The “number of loops” are the number of times the test is executed during each test. 100 test attempts were used for all conducted tests. For example, if 5 reader power levels are to be tested, and the number of loops is 100, then 500 total tests attempts will be conducted for each test.
- Motor Control – The linear slide motor control is found in the “settings” menu. The micro steps, distance traveled, start distance, end distance, velocity, and test increments can be modified.

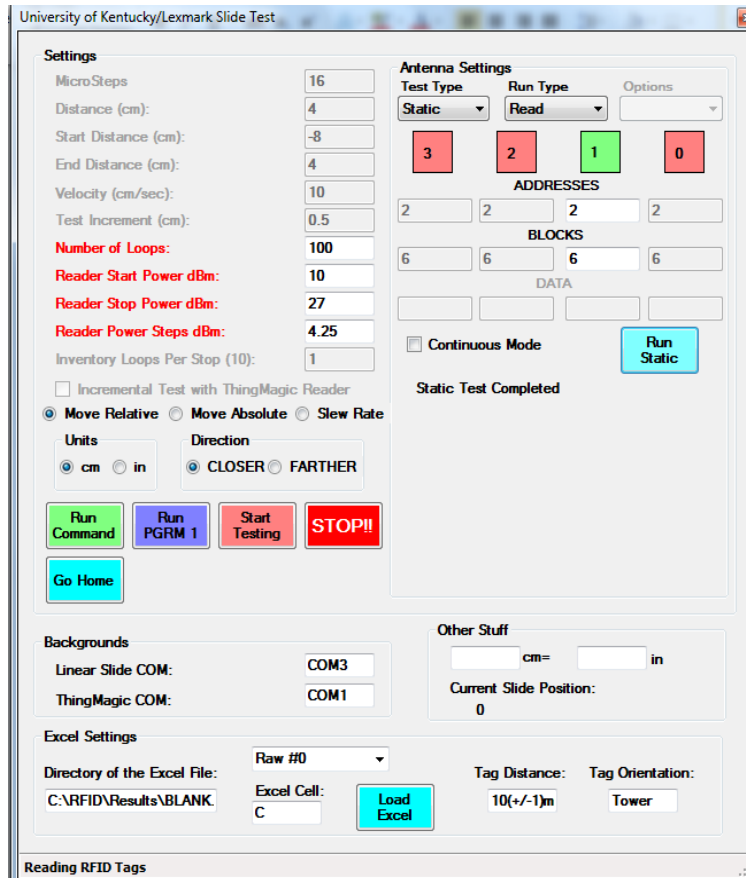


Figure 57: LexSlide1 graphical user interface (GUI)




## 7 Test Setup

### 7.1 Test Specimens

#### 7.1.1 Tags

A total of three different tag types were tested. The tags were selected for specific reasons for testing. The Raflatac Dogbone is the control tag. This is because it has been tested for all research conducted by the UK RFID team and Lexmark. The Alien SlimLine was selected because of its current wide use across many industries. The Impinj Paperclip was selected because it is a true near field tag. Far field antenna types cannot program the Impinj Paperclip tag.


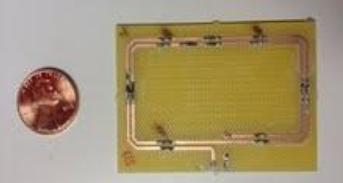

**Table 12: Summary of tested tags**

Vendor	Tag ID	IC Type	EPC	Applications	
Alien Technology [71]	ALN-9745 "SlimLine"	Higgs 4	128	Book spines Doors Shipping labels	
Raflatac DogBone [72]			96	Global Supply Chain, Pallets Cases, Item-level Asset tracking	
Impinj Paperclip [73]		Monza 2	96	Item level Pharma Supply Chain [74] Cloths	

#### 7.1.2 Antennas

A total of three different antennas were tested. The Meander is a far field antenna that is designed to program tag in near field ranges. In other words, the Meander was not designed to operate in the far field, but rather the near field. The Loop and Skyetek are both near field antennas. They can program both far and near field tags. Below is summary table of all tested antennas:

**Table 13: Summary of tested antennas**

Name	Field Type	Tag Field Type	Picture
Meander	Far Field	Far Field only	
Loop	Near Field	Far and Near Field	
Skyetek Loop	Near Field	Far and Near Field	

### 7.1.3 Reader

The reader used for all research is the Skyetek m9 [90]. The m9 was selected because it is optimized for reading and programming dynamic tags. This includes tags that are traveling at a certain speed and / or rotating. Secondary reasons are because of its small form factor and inexpensive RFID reader module. It also supports a wide variety of regions and tag types. The frequency ranges from 862 UHF to 955 UHF, with 915 UHF as the nominal. The power range is from 10 dBm to 27 dBm (0.5). The basic tag commands (identify, read, and write) for the following tag protocols are supported: EPC C1G1, EPC C1G2 (ISO18000-6C), ISO 18000-6B, and IPx.

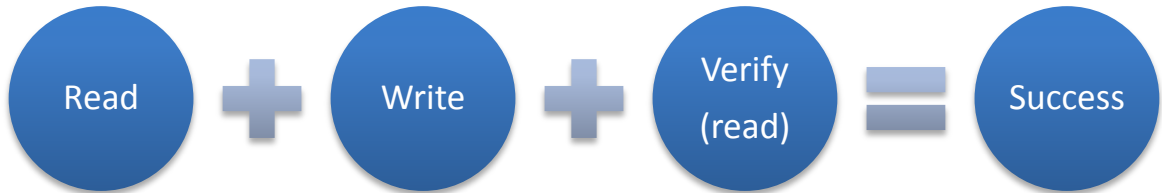


**Figure 58: Skyetek m9 Reader**

## 7.2 Test Types

When a tag is programmed three different operations are executed: read, write, verify (read). First, the tag must be read to identify that it is in the field of view of the antenna. Second, the tag

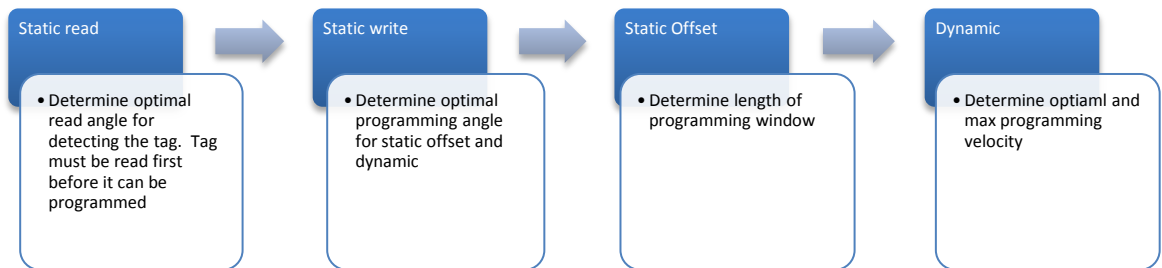
IC is programmed. Last, the tag data is verified that it is correct. All three operations must be executed to be a successful write. A failure occurs if any one of the three operations is not executed successfully.



**Figure 59: Successful Write = read + write + verify (read)**

### 7.2.1 Test Type Definitions

Many combinations of readers, tags, and antennas were tested. Each of these combinations are referred to as “systems”. Four test types were developed to test the effect of the programming variables on the various systems. Each test type has a unique purpose and each one is the foundation for the next test. The test types are: Static Read, Static Write, Static Write Offset, and Dynamic. Figure 60 has the each section and its primary purpose.



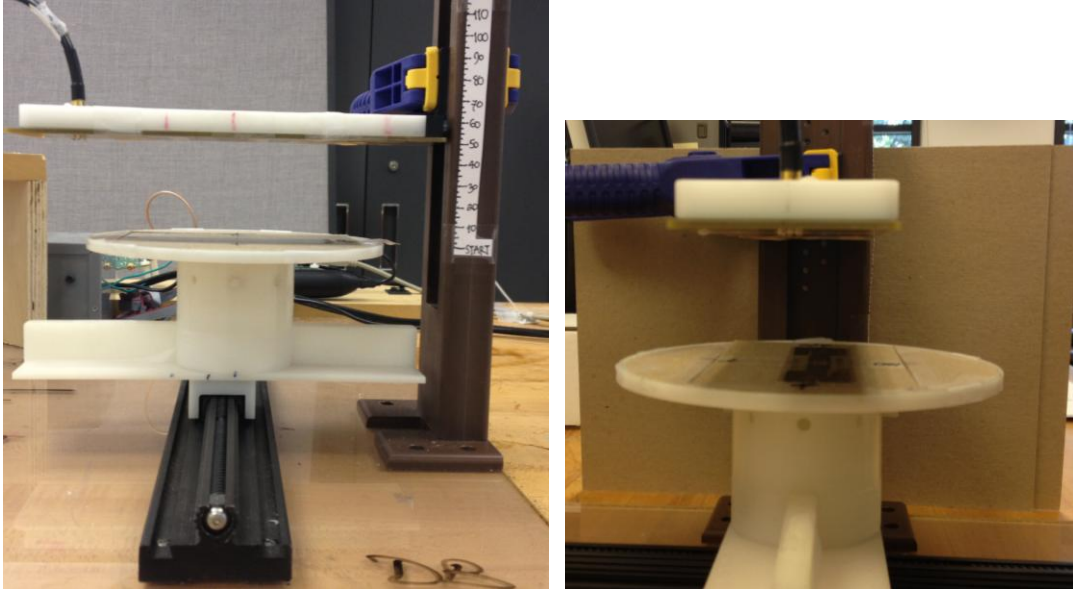
**Figure 60: Test Types - each test builds the foundation for the following test**

### 7.2.2 Test Type Definitions

#### Static Read

The purpose of the static read test is to determine the optimal read angle for various systems. Referring to figure 59 above, three tag operations are executed for each write performed to the tag. The test decouples the read operation from the overall programming process. This allowed the data to be compared to the Static Write test data and provide an additional layer of understanding.

The Static Read setup requires the IC of the tag to be aligned with the center of the antenna (this is true for all angles). The figure below has two pictures of the setup on the LexSlide1 showing the tag IC aligned with the center of the antenna.



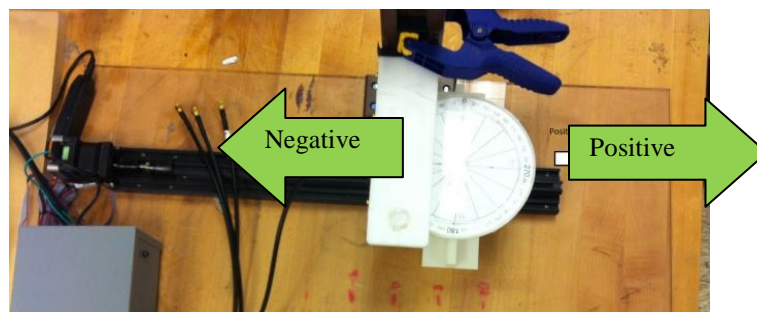
**Figure 61: Static test set up: IC of tag is aligned with center of antenna**

#### Static Write

The Static Write test is performed in the same way as the Static Read test. The difference is that all three tag operations are executed, resulting in the write process. The purpose of the Static Write test is to determine the optimal tag programming systems and corresponding programming variables. The data was used to reduce the number of variable for the Static Offset testing.

#### Static Offset

The purpose of the static offset testing is to determine the linear distance (or range) of the programming window. The tag is positioned and tested in the same way as the Static Write test, but with additional tag offset positions with respect to the antenna. The tag is positioned offset from the original position from the antenna in both directions. Figure 62 indicates direction.



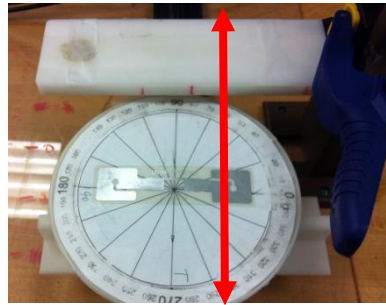
**Figure 62: Lexslide1 static offset direction**

There are two criteria specifications for tag to antenna orientation (Both are held constant throughout the entire test):

1. The tag and antenna are parallel with respect to one another

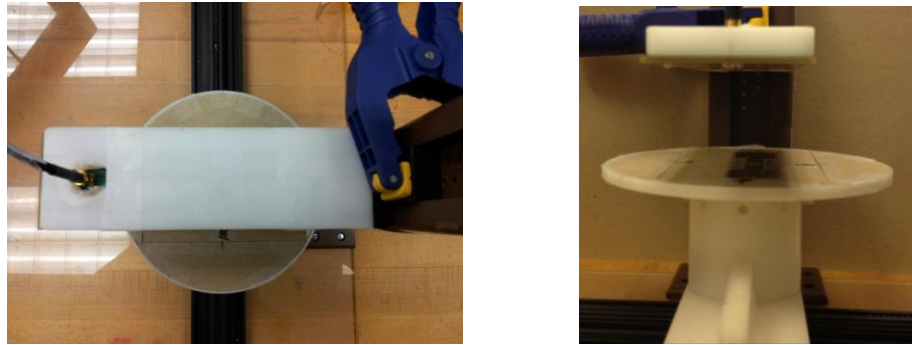


2. The tag IC and center of antenna are aligned in the X direction (linear slide translation axis indicated by red arrow in figure 63).



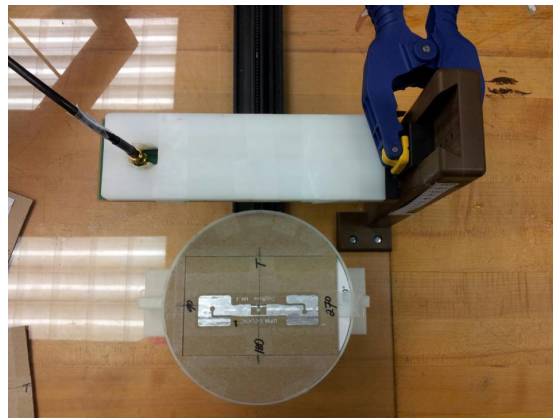
**Figure 63: Static Offset - Tag to antenna orientation and alignment**

The nominal or “0” position is shown in figure 64. Both pictures show the antenna centered directly under the antenna.



**Figure 64: Static Offset test at the “0” or “no offset” position. Top view (left) and side view (right)**

Figure 65 shows the tag position offset from the antenna.

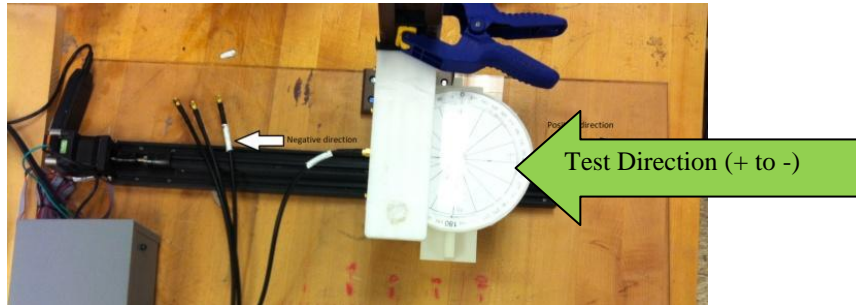


**Figure 65: Static Offset Test - tag offset from antenna in positive direction**

### Dynamic

The purpose of the dynamic test is to understand tag programming performance when the tag is in linear motion. The optimal system parameters and test conditions that were defined from the previous testing were used for Dynamic testing.

The setup is similar to the Static Offset test, but with motion. Test data is only collected in one direction starting from the most positive position and ending on the most negative position on the linear slide (figure 66)



**Figure 66: Lexslide1 static offset direction**

## **7.3 Test Parameters**

This section covers the basic test setup parameter sample size, variables and programming tag input.

### **7.3.1 Sample Size**

#### Tag Sample Size

Each tag type consisted of three tags and each tag was tested once for each test. This resulted in three data points per each test, which was then averaged.

#### Antenna Sample Size

Each antenna type consisted of a sample size of one.

### **7.3.2 Variables**

As discussed in more detail previously in section 6.2, the test variables are tag angles, air gap, and reader power levels. The possible values for each variable is as follows:

#### Angles

8 angles (0 (T), 45, 90, 135, 180, 225, 270, 315°)

#### Air gaps

4 air gaps (5, 25, 50, 75, 100 mm)

#### Reader Power Levels

5 power levels (10, 14.2, 18.5, 22.8, 27 mm)

### 7.3.3 Programming Tag input

Each tag write executed a 96 bit binary number. The number is stored in hexadecimal format, therefore; a 96 bit binary number/4 equals 24 hexadecimal numbers. The hexadecimal number stored in the tag is 1111 2222 3333 4444 5555 6666.

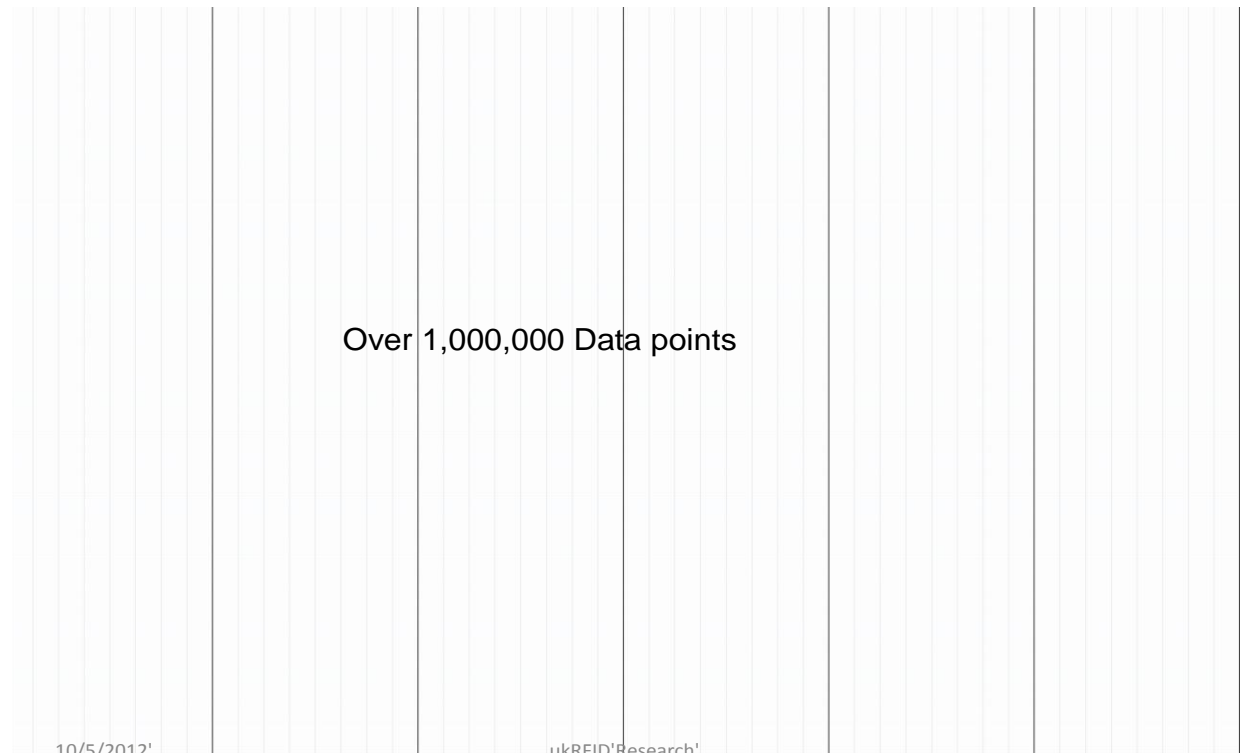
## 7.4 Data Output and the Secondary Process

Each test conducted consists of 100 data points. During the test the tag is interrogated, information is written to the IC and then verified 100 times. Each successful write results in a “yes” and each unsuccessful write results in a “no”. The end results in an average of the “no” results. For example, a 100% test result indicates that all 100 attempts were unsuccessful (all “no”). Another example, a 10% test result indicates that 10 attempts were unsuccessful, “no”, and 90 attempts were successful, “yes”.

### 7.4.1 Raw Data

Figure 67 and 68 shows a sample of the raw data output in Microsoft Excel. Each vertical column is a test conducted at a specified tag angle. Each block of data represents all tests conducted at a specified air gap. All the data represents the tests conducted for the tag type.

Careful data processing is critical because of the sheer amount of data. The secondary processes aid in preparing the data in a usable form for analysis. The following discusses the secondary process used for all data.



**Figure 67: Sample of raw data in Microsoft Excel**

Figure 68 has the raw data on the left. Each vertical row is a different tag angle of the same tag tested at all five reader power levels. The zoomed in section on located on the right. The top of the image displays the eight angles and the bottom is the averages for each.

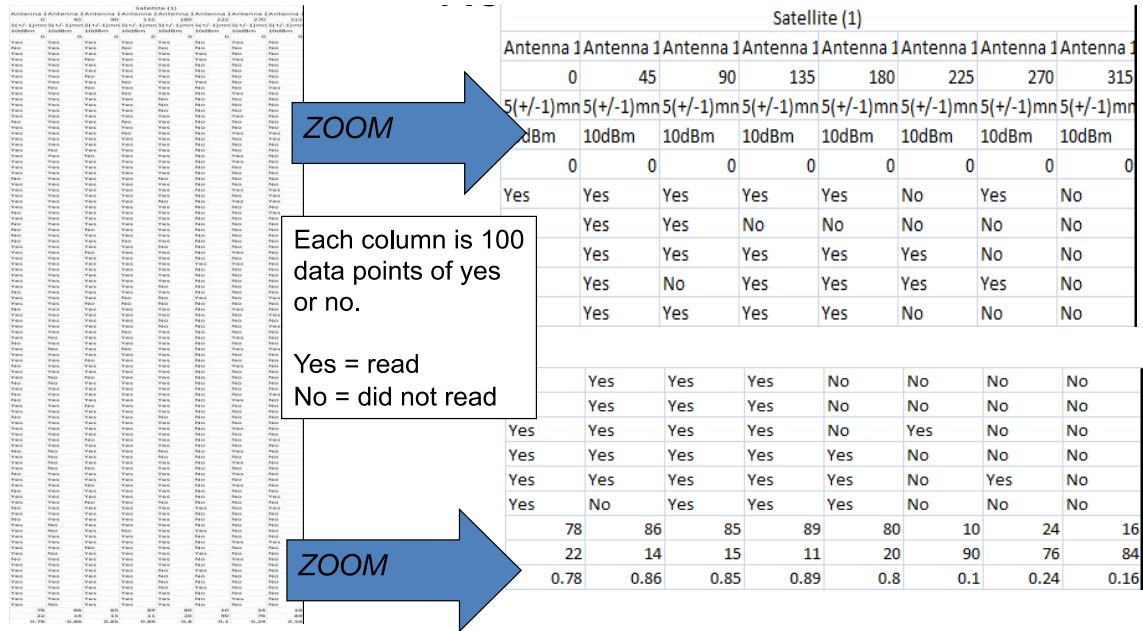


Figure 68: Sample output data and summary

### 7.4.2 Data Summary

A summary of the averages is created to place the data in a usable format for all tests conducted. Figure 69 shows a sample data summary for the Dogbone tag 2 (out of a set of three tags). The table lists the programming error for each test at all power levels (bold) and air gaps. For example, at an air gap of 5 mm results in the following programming error data points (10 dBm = 26%, 14.2 dBm = 31%, 18.5 dBm = 34%, 22.8 dBm = 39%, 27 dBm = 55%).

Dogbone-meander									
Airgap(mm)									
5	10	15	20	25	30	35	40	45	50
10dBm	10dBm	10dBm	10dBm	10dBm	10dBm	10dBm	10dBm	10dBm	10dBm
74	73	67	58	34	25	9	5	1	0
26	27	33	42	66	75	91	95	99	100
<b>26%</b>	<b>27%</b>	<b>33%</b>	<b>42%</b>	<b>66%</b>	<b>75%</b>	<b>91%</b>	<b>95%</b>	<b>99%</b>	<b>100%</b>
14.2dBm	14.2dBm	14.2dBm	14.2dBm	14.2dBm	14.2dBm	14.2dBm	14.2dBm	14.2dBm	14.2dBm
69	67	51	49	39	31	17	19	3	0
31	33	49	51	61	69	83	81	97	100
<b>31%</b>	<b>33%</b>	<b>49%</b>	<b>51%</b>	<b>61%</b>	<b>69%</b>	<b>83%</b>	<b>81%</b>	<b>97%</b>	<b>100%</b>
18.5dBm	18.5dBm	18.5dBm	18.5dBm	18.5dBm	18.5dBm	18.5dBm	18.5dBm	18.5dBm	18.5dBm
66	66	60	58	58	52	37	25	4	1
34	34	40	42	42	48	63	75	96	99
<b>34%</b>	<b>34%</b>	<b>40%</b>	<b>42%</b>	<b>42%</b>	<b>48%</b>	<b>63%</b>	<b>75%</b>	<b>96%</b>	<b>99%</b>
22.8dBm	22.8dBm	22.8dBm	22.8dBm	22.8dBm	22.8dBm	22.8dBm	22.8dBm	22.8dBm	22.8dBm
61	49	55	49	62	63	38	26	23	21
39	51	45	51	38	37	62	74	77	79
<b>39%</b>	<b>51%</b>	<b>45%</b>	<b>51%</b>	<b>38%</b>	<b>37%</b>	<b>62%</b>	<b>74%</b>	<b>77%</b>	<b>79%</b>
27dBm	27dBm	27dBm	27dBm	27dBm	27dBm	27dBm	27dBm	27dBm	27dBm
45	44	35	43	45	34	27	17	14	12
55	56	65	57	55	66	73	83	86	88
<b>55%</b>	<b>56%</b>	<b>65%</b>	<b>57%</b>	<b>55%</b>	<b>66%</b>	<b>73%</b>	<b>83%</b>	<b>86%</b>	<b>88%</b>

Figure 69: Sample data summary - raw data converted to a usable format

## 8 Test Methodology

The test methodology used was primarily to reduce the number of test from the initial text matrix. Each colored block represents all possible tests at a specific air gap (includes both antenna types and all three tag types). There are 18 total tests per block. Each cell inside the block is multiplied by the number of angles tests. There are 8 possible tag angles, which is 18 tests per block x 8 possible angles = 144 tests per block. There are 4 blocks for each air gap, therefore, there are = 576 test.

The number of tests increases by a factor of 5 when the reader power levels are included. The last parameter to multiply are the three tags per tag type. This results in a total of 8640 possible tests when all air gaps, tag angles, reader power levels, antenna types, tag types, test types and tags per tag type are included.

**Table 14: Test Matrix (576 possible tests)**

	5 mm						25 mm					
	Meander			Loop			Meander			Loop		
	DB	SL	PC	DB	SL	PC	DB	SL	PC	DB	SL	PC
Static Read	☐	☐	☐	☐	☐	☐	☐	☐	☐	☐	☐	☐
Static write	☐	☐	☐	☐	☐	☐	☐	☐	☐	☐	☐	☐
Static offset	☐	☐		☐	☐		☐	☐		☐	☐	
Dynamic	☐			☐			☐			☐		

	50 mm						75 mm					
	Meander			Loop			Meander			Loop		
	DB	SL	PC	DB	SL	PC	DB	SL	PC	DB	SL	PC
Static Read	☐	☐	☐	☐	☐	☐	☐	☐	☐	☐	☐	☐
Static write	☐	☐	☐	☐	☐	☐	☐	☐	☐	☐	☐	☐
Static offset	☐	☐		☐	☐		☐	☐		☐	☐	
Dynamic	☐			☐								

	100 mm					
	Meander			Loop		
	DB	SL	PC	DB	SL	PC
Static Read	☐	☐	☐	☐	☐	☐
Static write	☐	☐	☐	☐	☐	☐
Static offset						
Dynamic						

The raw data to complete the entire test matrix would be multiplied by 100, which would result in 864,000 data points. This was entirely too much data and needed to be reduced.

## 8.1 Test Reduction Strategy

As discussed in section 7.2, the four test types were designed to build a strong foundation to reduce the number of tests for the subsequent testing. Each of the static tests required the most amount of data. This is because they were the initial tests conducted; therefore, all defined programming variables were tested (i.e. 8, air gaps, reader power levels, tag types and antenna types).

The purpose of the static read and static write tests were to identify optimal angels, air gaps, and reader power levels for each tag type and antenna type combination (i.e. programming system). Once the optimal programming variables were identified, they were used for the static offset and dynamic tests.

The matrix below is for all tests conducted and lists each test factor. The initial test, Static Read, consisted of 2,880,000 data points and required 5760 manual tests. The last test conducted, Dynamic, consisted of 90,000 and 900 manual tests. This was a 97% total reduction in data points.

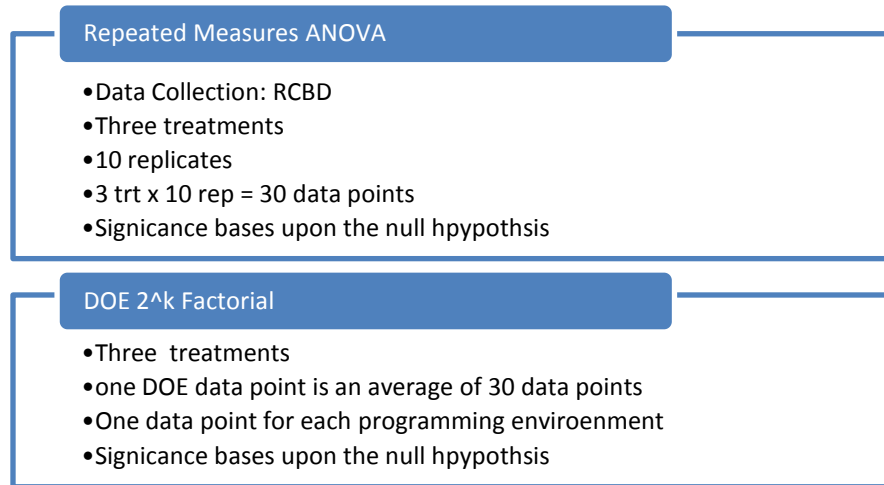
The testing required two years and a team of research students.

	tag Types	Antenna Types	antenna angles	air gaps	power levels	Linear Distances	linear Velocities	tag sample size	treatments	Total Tests	Manual Tests	Data points	Test Data Reduction	
													Absolute	Relative
Static Read	2	3	8	4	5	1	0	3	10	28800	5760	2880000	100%	
Static Write	3	3	8	1	5	1	0	3	10	10800	2160	1080000	63%	63%
Static Offset 1	3	3	1	2	5	24	0	3	10	64800	12960	6480000	-125%	-500%
Static Offset 2	1	3	1	3	5	24	0	3	10	32400	6480	3240000	-13%	50%
Dynamic	1	2	1	3	1	n/a	5	3	10	900	900	90000	97%	97%
												13,770,000		

**Figure 70: Test Matrix - test reduction strategy**

## 9 Statistical Analysis

Two types of statistical analysis were applied to each test: Repeated Measures ANOVA and DOE. The repeated measures ANOVA (i.e. rANOVA) checked if a significant difference existed between the tags (called treatments). Three treatments were used for each tag type. The DOE 2<sup>k</sup> factorial testing determined which of the main effects and interactions were significant.



**Figure 71: Statistical Analysis types: Repeatability and ANOVA**

### 9.1 Programming Environments

A complete programming system includes three main components: reader, antenna and a tag. A programming environment consists of the same components, but includes the specific type of each component and the specific programming parameters.

The table below consists of a few possible programming environments:

**Table 15: Examples of programming environments**

Environment	Reader Type	Antenna Type	Tag Type	Power Level	Angle	Air Gap	Linear Speed
1	Skyetek M9	Meander	Dogbone	10 dBm	45	5 mm	10 cm/s
2	ThingMagic 5e	Loop	Slim Line	27 dBm	270	25 mm	25 cm/s

### 9.2 Repeated Measured ANOVA (rANOVA)

The repeatability among treatments statistical testing was conducted first. The purpose was to confirm that the test results could be trusted for subsequent testing. This type of testing was conducted for each possible programming environment for the static read and static write tests.



The purpose of conducting the repeatability tests for all possible programming environments was to ensure that the data could be trusted for all subsequent tests.

The tests results were used to determine which programming environments were repeatable and which programming environments that could be repeated. The repeatable programming environments were used for subsequent testing. Each programming environment was treated independently and analyzed independently.

### 9.2.1 Data Collection

Randomized Complete Block Design (RCBD) was used for the statistical model to control known sources of variability between tag to tag (i.e. treatments) and to reduce error within the blocks. The blocking constraint is that each of the three tags of the tested tag type appears randomly once per block. The tags were randomly selected from a larger population.

The table below has the test sequence for the the Meander antenna type and Dogbone tag type. The test is repeated 10 times, called blocks, for each Dogbone tag. Each block is tested one at a time. For example, according to the table below the test sequence for block 1 is in the following order: Test 1 = Dogbone 2, Test 2 = Dogbone = 1, Test 3 = Dogbone 3 = 3. A randomized chart was produced for each test conducted.

**Table 16: Randomized Complete Block Design (RCBD): Example test sequence summary for Dogbone tag and Meander antenna type.**

	DB-Meander									
Block	1	2	3	4	5	6	7	8	9	10
Dogbone1	2	2	1	2	3	3	1	2	2	1
Dogbone2	1	3	2	1	1	2	2	1	3	2
Dogbone3	3	1	3	3	2	1	3	3	1	3

### 9.3 Statistical Model: Randomized Complete Block Design (RCBD)

The statistical model used is as follows:

$$Y_{ij} = \mu + \tau_i + \rho_j + e_{ij}$$

$$i = 1, 2, 3 \quad j = 1, \dots, 10$$

**Equation 45**

Where:

- $\mu$  is a population mean for tags
- $\tau_i$  is a (fixed) treatment effect (tag samples),  $i = 1, 2, \dots, \tau$  and  $\sum_{i=1}^t \tau_i = 0$
- $\rho_j$  is a (fixed) block effect (blocked by test sequence),  $j = 1, 2, \dots, r$  and  $\sum_{i=1}^r \rho_i = 0$
- $e_{ij} \sim iidN(0, \sigma_e^2)$  is an error term for variation among plots.
- In the above example for the Meander antenna and Dogbone tag,  $t = 3$ ,  $r = 10$ ; therefore, there are a total of  $tr = 30$  observations.

Where  $\mu$  is a parameter common to all treatments called the overall mean and  $\tau_i$  is parameter unique to the  $i$ th treatment called the  $i$ th treatment effect.  $\epsilon_{ij}$  is the random error component that incorporates all other sources of variability in the experiment including measurement, variability arising from uncontrolled factors, differences between the tags, and general background noise.

The model errors are assumed to be normally and independently distributed with mean zero and variance  $\sigma^2$ . Also, the variance  $\sigma^2$  is assumed to be constant for all levels of the factor. This implies that the observations are mutually independent.

Analysis of variance (ANOVA) is used to partition the total variability into component parts. This method allows the source of variability to be identified. In this case, the variability will be identified between tag (treatments) or within the tag itself (within treatments)

The total corrected sum of squares is used to measure the overall variability in the data.

$$SSTot = \sum_{i=1}^t \sum_{j=1}^r (Y_{ij} - \bar{Y}_{..})^2$$

**Equation 46**

$\bar{y}_{ij}$  is the average programming average per power level of a specific combination. The  $\bar{y}_{..}$  is the grand average of all the observations per power level of a specific combination. Three tags were tested per tag type; therefore,  $a$  equals three. Each test was replicated 10 times, therefore,  $n$  equals 10.

The variability between the tags can be measured with the sum of squares due to treatments

$$SSTrt = \sum_{i=1}^t \sum_{j=1}^r (\bar{Y}_{i.} - \bar{Y}_{..})^2 = r \sum_{j=1}^t (\bar{Y}_{i.} - \bar{Y}_{..})^2$$

**Equation 47**

Where the  $\bar{y}_{i.}$  represents the average of the observations within the  $i$ th treatment. The variability between the blocks can be measured with the sum of squares due to blocks

$$SSBlk = \sum_{i=1}^t \sum_{j=1}^r (\bar{Y}_{.j} - \bar{Y}_{..})^2 = t \sum_{j=1}^r (\bar{Y}_{.j} - \bar{Y}_{..})^2$$

**Equation 48**

Total Error

$$SSErr = \sum_{i=1}^t \sum_{j=1}^r (Y_{ij} - \bar{Y}_{i.} - \bar{Y}_{.j} + \bar{Y}_{..})^2 = SSTot - (SSBlk + SSTrt)$$

**Equation 49**

Assumptions of the RCBD:

1) Sampling:

a. The blocks are independently sampled

b. The treatments are randomly assigned to the experimental units within a block.

2) Homogeneous Variance: the treatments all have the same variability, i.e. they all have the same variance

3) Approximate Normality: each population is normally distributed

### 9.3.1 ANOVA Table for a Randomized Complete Block Design

The benefits of the RCBD is that both effects of the treatments ( $\tau$ ) and the blocking ( $\rho$ ) are calculated. The blocking constraints effect how the data is analyzed. A normal ANOVA is not sufficient. Below is an ANOVA table for the RCBD:

**Table 17: ANOVA table for a Randomized Complete Block Design (RCBD)**

Source	Df	SS	MS	F-statistic
Trt	t-1	SSTrt	MSTrt	F=MStrt/MSE
Block	r-1	SSBlk	MSBlk	
Error	(t-1)(r-1)	SSPE	MSE	
Total	tr-1	SSTot		

### 9.3.2 The null Hypothesis

The null hypothesis is used determine if significant relationship exists between the explanatory variable (i.e programming variables) and the response variables (i.e. programming error). The data presented here used the null hypothesis to formally investigate if no differences in the treatment means.

The hypothesis is based upon the treatment means are equal. Each  $\mu_i$  represents each tag treatment and there are three treatments per tag type.

$$H_0: \mu_1 = \mu_2 = \mu_3$$

**Equation 50**

The decision rule is the criteria used to decided if the null hypothesis should be rejected or not be rejected. Both the F-statistic and p-value is shown below.

F-Statistic

$$\text{Reject } H_0 \text{ if } F_0 > F_\alpha$$

$$\text{Do NOT Reject } H_0 \text{ if } F_0 < F_\alpha$$

p-value

*Reject  $H_0$  if  $p - value > \alpha$*

*Do NOT Reject  $H_0$  if  $p - value < \alpha$*

Where  $\alpha = 0.05$

<b>P value</b>	<b>Wording</b>
< 0.0001	Extremely significant
0.0001 to 0.001	Extremely significant
0.001 to 0.01	Very significant
0.01 to 0.05	Significant
$\geq 0.05$	Not significant

The test statistic  $F_o$  can be calculated and the p-value test statistic is calculated by statistic software. The  $F_o$  is calculated by

$$F_o = \frac{MSR}{MSE}$$

**Equation 51**

Where

$$MSR = \frac{SSR}{1}$$

$$MSE = \frac{SSE}{n - 2}$$

**Equation 52**

The  $F_\alpha$  is found in the F-tables at 0.05 confidence by using the equation below (where  $\alpha = 0.05$  and n=total observations)

$$F_{(\alpha;1,n-2)}$$

**Equation 53**

A decision can now be made by using the F-statistic or p-value on whether or not the null hypothesis should be rejected. It is worth noting that this process relies on more than the calculated decision alone. For example, some data sets that fail the null hypotheses are not rejected. These decisions are made on understanding and experience with the data as a whole. These decisions were not common, but did occur (these decisions are noted in the data).

## 9.4 Calculation Software

Two different types of software were used to compute the statistics. Statistical programs were created in Microsoft Excel to compute the design of experiments and ANOVA. Mini-tab was also used for larger sets of data.

2 <sup>3</sup>																							
Treatment combinations	Factorial Effect							Treatments				Factor Effects	contrasts	Sum of Squares	Contribution	DOF	Mean Square	F-Value	Significant	from book	alpha	K(# of factor/N-k-1)	
	A	B	AB	C	AC	BC	ABC	1	2	3	Total												AVG
(1)	1	-1	-1	1	-1	1	-1	100	100	100	300	100	(1)										
A	1	1	-1	-1	-1	-1	1	63	55	57	175	58.33	A	-13.8333	-166	1148.1667	6%	1	1148.166667	20.7813	YES		
B	1	-1	1	-1	-1	1	-1	100	100	100	300	100	B	37.66667	452	8512.6667	41%	1	8512.666667	154.0754	YES		
AB	1	1	1	1	-1	-1	-1	100	100	100	300	100	AB	-0.33333	-4	0.66666667	0%	1	0.66666667	0.012066	NO		
C	1	-1	-1	1	1	-1	1	31	9	32	72	24	C	-31	-372	5766	28%	1	5766	104.362	YES		
AC	1	1	-1	-1	1	1	-1	42	35	39	116	38.67	AC	7	84	294	1%	1	294	5.321267	YES		
BC	1	-1	1	-1	1	-1	1	100	100	100	300	100	BC	16.83333	202	1700.1667	8%	1	1700.166667	30.77225	YES		
ABC	1	1	1	1	1	1	1	77	70	68	215	71.67	ABC	-21.1667	-254	2688.1667	13%	1	2688.166667	48.6546	YES		
Standard Order								1778	74.08	error	SSE	Pure Error	442	2%	8	55.25	Significant if the Ho is Rejected. This means that the coeff						
Regression EQ												SST	Total error	20551.833									
y_hat												SSR	Residual Error	20109.833									
	b0	b1	b2	b3	b12	b13	b23	b123															
	74.0833	-6.92	18.83	-15.5	-0.17	3.5	8.417	-10.6															

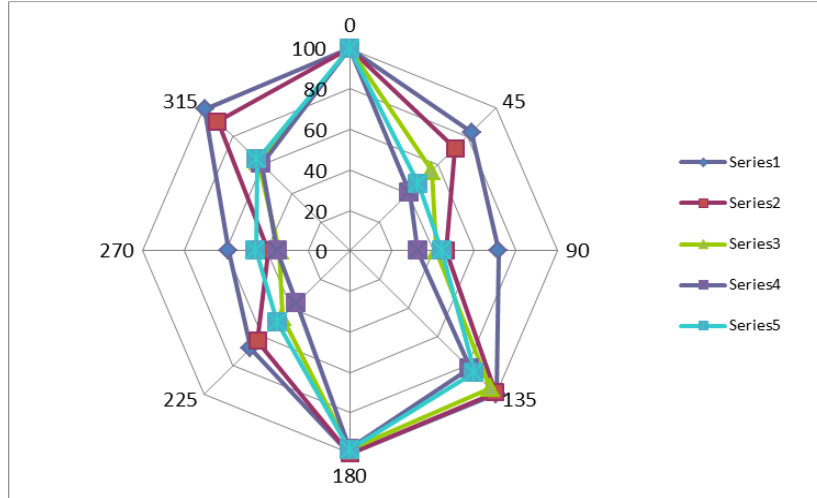
Figure 72: 2<sup>3</sup> factorial Design Test

## 9.5 Output data Types

### 9.5.1 Programming Error Radar Plots

The programming error radar plots are a simple graphical method for displaying the programming error of the RFID system at all tested angles. Below is an example of a programming error radar plot of a RFID system tested at eight different angles. The line rays that originate from 0 represent each angle tested. Each circle represents the programming error of the RFID system in 20% increments.

Every test conducted is tested at five different reader power levels and is represented by the different colored lines. According to the error radar plot, the optimal tag angle and reader power level occurs at a tag angle of 270° and 90° with a reader power level of 22.8 dBm. The worst performance occurs when the tag angle is 0° and 180° at all reader power levels.



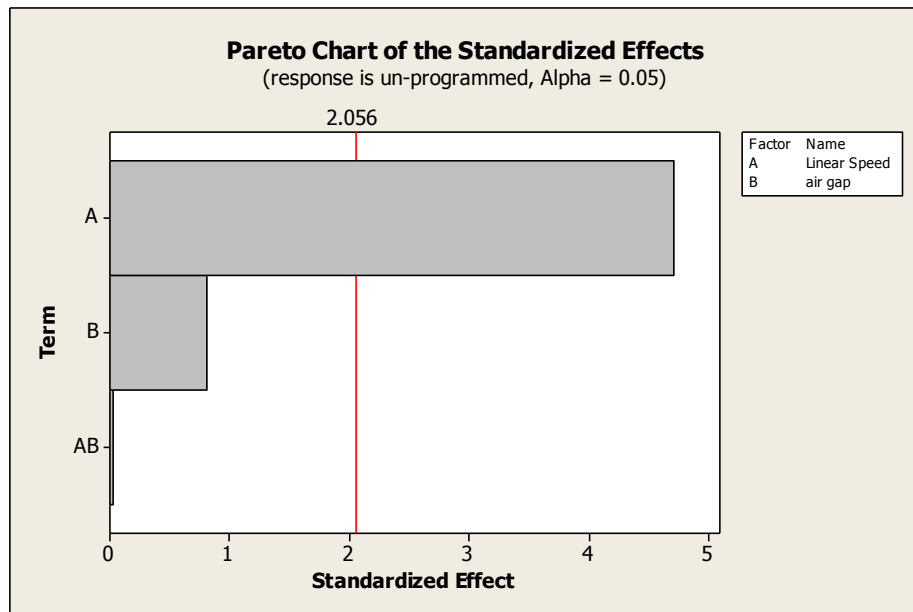
**Figure 73: Example Programming Error Radar Plot**

Programming error radar plots have proven to be a quick and effective method in determining the optimal tag angle and reader power level for RFID systems.

### 9.5.2 Main Effects and Interaction Pareto Chart

The main effects and interaction bar plots are used to determine the critical programming variables and / or their interactions. As discussed in section 6.2, the main programming variables are power (A), air gap (B) and tag angle (C).

The example chart below indicates that the main effect with the most contribution to tag programming is the power (A) and the interaction between the power (P) and tag angle (C). The main effects and interaction Pareto charts are useful in identifying which main programming variables and their interactions have the most influence in programming tags.



**Figure 74: Example main effects and interaction Pareto Chart**

It is worth noting that “error” represented on the chart represents the unknown contribution in programming change. A few examples sources of unknown contributions are from bad test practices, faulty equipment, unstable, and environment.

Bellow is an example of three different tags (Button, Satellite, and Dogbone) tested at two different air gaps (5 mm and 10 mm). The data is organized horizontally by tag and vertically by air gap. Programming error radar plots and main effects and interaction plots are provided.

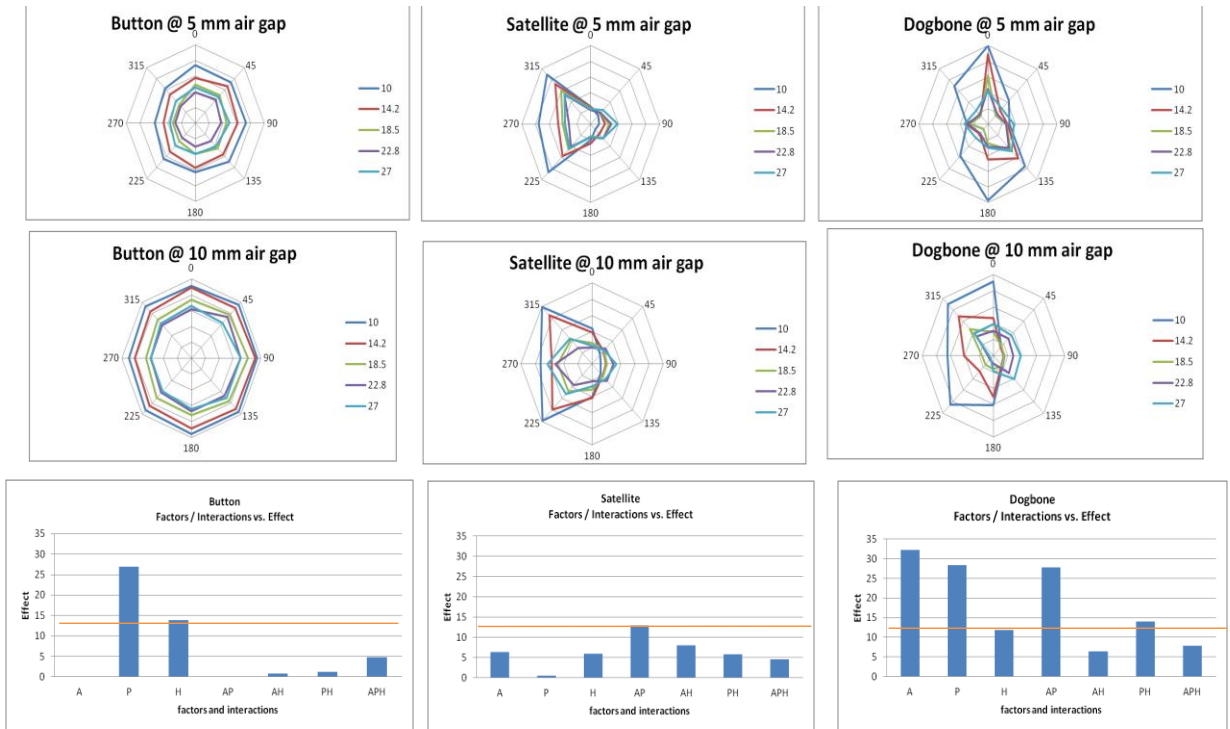
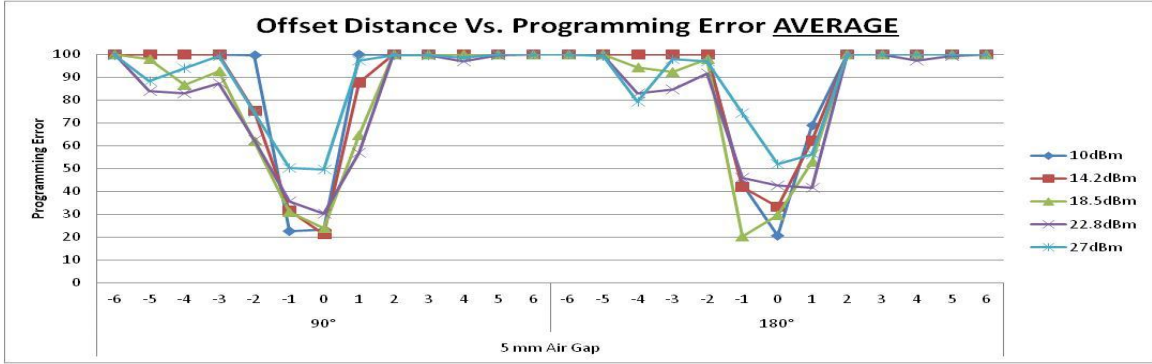


Figure 75: Example data - 3 tag types and 2 air gaps

### 9.5.3 Offset Testing Plots

As discussed in section 7.2, the purpose of offset testing is to determine the length of the programming window. The chart below is an offset test conducted over a total of 12 cm (6 cm in each direction) in 1 cm increments. The test was conducted at the two optimal programming tag angles, 90° and 180°. The data below indicates that when the tag is at an angle of 90°, the tag’s programming window is approximately 2 cm (0 cm to -1 cm) for all reader power levels. Also, when then tag is at an angle of 180°, the tag’s programming windows is approximately 3 cm (2 cm to – 1 cm) for all reader power levels.



**Figure 76: Example offset testing plot for 90° and 180° tag angles**

The offset testing plots have proven to be useful in determining the length of the programming window. This information can be used to help determine when the tag is initially detected by the RFID system when the tag is in motion, as in the RFID printer. Larger programming windows are preferred because they provide more time for the programming operations to be executed.

The programming window becomes more important as demands increase during the tag programming. For example, more time is required to execute the following demands: increased data size to the EPC, access the user memory, and password security.



# 10 Test Analysis

As mentioned in section 7.2.1 Test Type Definitions, each test type builds the foundation for the subsequent test. The overall goal is to simulate the dynamic printing environment. Before the dynamic testing could be conducted the fundamental understanding must first be achieved. The fundamental understanding was achieved by conducting the static read, static write, and static offset tests. The captured learning from the three tests paved the path to the dynamic testing.

This section discussed each individual test then ties them all together at the end. It is worth noting that many questions were derived from the test data and not all of them were answered. All of these questions were collected and discussed in the “Moving Forward” section located at the end of the paper.



**Figure 77: Test strategy**

## 10.1.1 No variance between treatments

The variance between treatments was tested by using the F-statistic. The table below is based on the F-statistic for all write test conducted. The calculated F-statistic was based upon the cut off value of 2.46. Six of the eleven red cells are 2.887 or lower, which is close to the cut-off value. The data point for Slim Line, Skyetek and 10 dBm has the highest calculated F-statistic, at 5.769. The data was not repeated because a decision was made not to move forward with the Skyetek antenna.

Table 18: rANOVA summary (F-statistic)

		5 mm								
		Paper Clip		Dogbone			Slim Line			
		Loop	Skyetek	Loop	Skyetek	Meander	Loop	Skyetek	Meander	
10 dBm	0	1.869		0.908	0.816355	1.000	0.279	1	1.000	
14.2 dBm		0.750		1.254	0.838972	1.000	1.625	1	1.000	
18.5 dBm		2.056		2.185	1.861027	1.000	0.707	0.676136	0.676	
22.8 dBm		0.586		0.744	1.668796	1.000	0.822	0.677686	0.678	
27 dBm		1.139		0.671	0.803279	1.000	0.595	1	1.000	
10 dBm	45	0.142		1.088	0.418	0.768	1.119	2.263	1.000	
14.2 dBm		1.347		1.681	0.909	0.569	1.865	0.793	1.000	
18.5 dBm		0.540		0.617	1.383	1.273	1.720	0.531	1.000	
22.8 dBm		1.786		1.445	1.958	1.938	0.496	0.924	0.629	
27 dBm		0.797		0.430	1.063	0.566	0.806	1.022	0.778	
10 dBm	90	1.037		2.506	0.899	1.017	0.880	0.738	0.538	
14.2 dBm		1.157		2.431	0.451	1.038	1.824	1.058	0.996	
18.5 dBm		1.168		0.273	0.594	0.622	0.562	0.471	0.428	
22.8 dBm		2.381		1.228	2.243	1.298	0.792	1.427	2.110	
27 dBm		0.829		0.842	2.123	1.490	1.393	1.205	0.875	
10 dBm	135	0.373		2.230	0.720	0.924	1.638	0.967	1.000	
14.2 dBm		1.128		0.963	1.670	0.849	1.322	1.285	3.038	
18.5 dBm		0.488		0.848	1.023	1.457	0.363	1.893	0.519	
22.8 dBm		1.561		2.497	0.185	0.280	1.045	1.332	0.532	
27 dBm		1.093		2.247	0.410	0.498	1.270	0.641	1.000	
10 dBm	180	0.813		1.356	0.775256	0.696	3.237	1.256	1.000	
14.2 dBm		0.885		2.233	3.40569	0.471	2.441	0.968	1.000	
18.5 dBm		1.962		2.142	1.394743	0.947	0.345	0.670	1.000	
22.8 dBm		0.783		2.366	1.588255	0.962	0.309	1.968	1.000	
27 dBm		1.149		2.037	2.864546	0.267	2.625	1.000	1.000	
10 dBm	225	0.955		2.170	0.628	1.000	2.571	0.736	0.621	
14.2 dBm		0.793		0.571	0.770	0.872	0.257	0.818	0.961	
18.5 dBm		0.893		0.699	0.633	0.636	0.459	0.262	0.991	
22.8 dBm		0.428		0.808	0.904	1.084	0.873	1.435	2.263	
27 dBm		1.533		0.793	0.744	1.190	0.177	1.404	0.397	
10 dBm	270	0.817		0.562		0.279	2.366	5.769	0.475	
14.2 dBm		0.476		0.846		0.737	1.629	1.788	1.172	
18.5 dBm		0.816		1.216		1.584	1.889	0.608	0.950	
22.8 dBm		1.591		0.780		0.959	1.137	2.204	0.221	
27 dBm		0.841		1.623		1.148	2.309	0.648	1.896	
10 dBm	315	1.570		0.596	0.281	0.279	1.004	2.497	0.475	
14.2 dBm		1.102		0.802	0.603	0.737	0.968	0.522	1.172	
18.5 dBm		1.224		1.643	0.502	1.584	1.093	0.783	0.950	
22.8 dBm		1.000		1.081	1.273	0.959	1.100	0.673	0.221	
27 dBm		0.576		0.666	1.443	1.148	1.211	2.887	1.896	
cut off		2.46 F (.05,9,18)								

Table 19: rANOVA summary (programming error)

		5 mm						
		Paper Clip	Dogbone			Slim Line		
		Loop	Loop	Skyetek	Meander	Loop	Skyetek	Meander
10 dBm	0	10.033	2.133	72.766667	99.967	77.566667	99.966667	99.9666667
14.2 dBm		21.900	7.000	78.6	99.967	87.966667	99.966667	99.9666667
18.5 dBm		46.733	16.067	85.533333	99.967	94.966667	98.4	98.4
22.8 dBm		77.000	36.367	81.833333	99.967	99.233333	99.466667	99.4666667
27 dBm		59.133	50.100	95.533333	99.967	86.066667	99.966667	99.9666667
10 dBm	45	10.867	8.967	64.133	66.733	19.700	72.400	99.967
14.2 dBm		25.033	13.867	43.133	63.300	34.233	67.833	99.967
18.5 dBm		51.433	28.367	31.867	50.500	50.400	60.800	99.967
22.8 dBm		78.200	53.100	69.033	46.033	69.767	54.833	99.767
27 dBm		59.800	58.233	97.700	59.700	67.300	60.733	99.900
10 dBm	90	13.000	26.033	49.167	25.800	8.400	69.667	91.767
14.2 dBm		23.700	17.333	38.400	33.500	26.133	64.500	83.767
18.5 dBm		51.000	21.600	30.233	39.333	47.267	55.200	75.133
22.8 dBm		79.700	43.733	36.567	45.033	65.633	57.800	59.100
27 dBm		60.233	55.200	53.600	63.500	53.967	86.233	89.900
10 dBm	135	12.533	21.133	69.233	41.200	10.867	79.767	99.700
14.2 dBm		26.033	34.367	44.833	47.233	30.000	73.867	99.567
18.5 dBm		51.800	47.600	48.233	41.400	47.633	64.633	96.167
22.8 dBm		79.567	76.100	79.233	44.467	66.433	67.433	97.367
27 dBm		58.067	74.500	98.567	63.567	59.667	88.767	99.967
10 dBm	180	14.767	25.900	95.166667	74.600	9.567	97.233	99.967
14.2 dBm		33.067	16.333	92.433333	68.367	25.033	97.200	99.967
18.5 dBm		56.433	23.933	85.966667	54.733	41.800	99.233	99.967
22.8 dBm		79.300	52.900	83.333333	46.567	54.233	99.767	99.967
27 dBm		61.600	59.200	88.9	60.833	51.433	100.000	99.967
10 dBm	225	12.133	36.967	61.133	99.967	22.667	33.033	97.600
14.2 dBm		26.400	30.100	65.667	96.133	39.000	42.933	91.900
18.5 dBm		53.067	34.933	61.033	74.400	51.267	44.600	83.800
22.8 dBm		80.133	55.367	77.633	56.800	68.133	42.367	85.733
27 dBm		58.300	72.300	96.067	62.000	69.267	56.500	97.633
10 dBm	270	9.733	5.000	61.500	40.367	15.900	29.567	92.367
14.2 dBm		22.833	13.733	68.230	43.133	30.333	38.800	86.567
18.5 dBm		48.433	22.433	64.200	38.900	44.400	43.133	78.700
22.8 dBm		78.533	54.667	73.250	41.167	62.067	46.900	81.333
27 dBm		58.733	63.467	92.365	59.333	54.067	51.100	94.100
10 dBm	315	10.900	2.367	60.400	40.367	73.133	34.767	92.367
14.2 dBm		22.400	6.167	75.467	43.133	67.333	59.600	86.567
18.5 dBm		45.900	15.367	67.767	38.900	68.800	66.300	78.700
22.8 dBm		78.433	35.067	68.333	41.167	93.633	67.733	81.333
27 dBm		58.900	52.500	85.033	59.333	99.700	68.700	94.100

## 10.2 Static Read



The purpose of the static read test was to lay a sound foundation for tag programming by identifying the optimal programming sub systems for reading RFID tags. Even though the test is a read only test it is relevant for programming. This is because the tag must be read before it can be programmed. The green highlighted row in the table below represents the degrees of freedom for each programming variable and test parameter.

**Table 20: Static Read Text Matrix (green)**

	tag Types	Antenna Types	antenna angles	air gaps	power levels	Linear Distances	linear Velocities	tag sample size	treatments	Total Tests	Manual Tests	Data points	Test Data Reduction	
													Absolute	Relative
Static Read	2	3	8	4	5	1	0	3	10	28800	5760	2880000	100%	
Static Write	3	3	8	1	5	1	0	3	10	10800	2160	1080000	63%	63%
Static Offset 1	3	3	1	2	5	24	0	3	10	64800	12960	6480000	-125%	-500%
Static Offset 2	1	3	1	3	5	24	0	3	10	32400	6480	3240000	-13%	50%
Dynamic	1	2	1	3	1	n/a	5	3	10	900	900	90000	97%	97%

### 10.2.1 Test Parameters

The static read test consisted of the most degrees of freedom. This is because it was the first test conducted and for this research. Limited test data existed outside of this research and the static read test was conducted. The hope is that the data was repeatable; therefore, it could be trusted.

In all, 2,880,000 data points were collected during the testing. The sheer amount of data made it difficult to analyze. The methods discussed earlier did help make the process more automatic and less time consuming.

**Table 21: Static Read Test Parameters**

Tag Types	Dogbone	Slim line						
Tag Samples (treatments)	3							
Blocks (replicates)	10							
Antenna Types	Meander	Loop	Skyetek					
Antenna Angles	0	45	90	135	180	225	270	315
Air Gaps	5	25	50	100				
Power levels	10	14.2	18.5	22.8	27			
Linear Velocity	n/a							

## 10.2.2 Statistical Analysis

This section discusses the test results conducted with the Dogbone and Slim Line tag and each of the three antenna types at a 5 mm air gap. A total of 720,000 data points were collected for this set of data (2 tag type x 3 tag samples x 10 replicates x 3 antenna types x 8 angles x 1 air gap x 5 power levels x 100 loops = 720,000 data points).

The DOE 2<sup>2</sup> factorial results are listed below. The tables are the p-values and F statistic from the null hypothesis analysis. The two factors tests were: power level (P), angle (A) and the interaction between power level and angel (P\*A). The green cells indicated that the programming factor or interaction has a significant effect on the programming error. The red cells indicated that the programming factor or interaction does not have a significant effect on the programming error.

Note that the interaction between the power level and angel (P\*A) should be considered along with the individual main effects results. This is because one of the main effect values could be large and the other be small, which could result in the interaction significant.

**Table 22: Static Read null hypothesis (p-values)**

			p-value		
			P	A	P*A
Paper Clip	Loop	5 mm	n/a	n/a	n/a
Dogbone	Meander	5 mm	0.000	0.001	0.033
Dogbone	Loop	5 mm	0.000	0.238	0.036
Dogbone	skyetek	5 mm	0.012	0.009	0.502
Slim Line	Meander	5 mm	0.998	0.959	0.903
Slim Line	Loop	5 mm	0.049	0.02	0.933
Slim Line	skyetek	5 mm	0.167	0.000	0.269

**Table 23: Static Read null hypothesis (F-statistic)**

			F-value		
			P	A	P*A
Paper Clip	Loop	5 mm	n/a	n/a	n/a
Dogbone	Meander	5 mm	15.71	12.55	4.95
Dogbone	Loop	5 mm	15.230	1.44	4.75
Dogbone	skyetek	5 mm	7.07	7.74	0.46
Slim Line	Meander	5 mm	0.00	0.00	0.02
Slim Line	Loop	5 mm	4.090	5.92	0.01
Slim Line	skyetek	5 mm	1.99	25.650	1.26
			2.028		
			cut off value		

The statistical analysis was performed in Minitab. Below is an example data set produced from the Minitab analysis. The p-values and F-statistic are highlighted for each of the main effects, power level and angel, and the interaction between the main effects.

## Factorial Fit: programming error versus power level, angle

Estimated Effects and Coefficients for programming error (coded units)

Term	Effect	Coef	SE Coef	T	P
Constant		79.317	2.310	34.34	0.000
power level	-9.200	-4.600	3.258	-1.41	0.167
angle	35.733	17.867	3.528	5.06	0.000
power level*angle	11.165	5.583	4.977	1.12	0.269

S = 14.6067      PRESS = 9355.34  
 R-Sq = 44.53%    R-Sq(pred) = 32.44%    R-Sq(adj) = 39.91%

Analysis of Variance for programming error (coded units)

Source	DF	Seq SS	Adj SS	Adj MS	F	P
Main Effects	2	5897.5	5897.5	2948.7	13.82	0.000
power level	1	425.2	425.2	425.2	1.99	0.167
angle	1	5472.3	5472.3	5472.3	25.65	0.000
2-Way Interactions	1	268.4	268.4	268.4	1.26	0.269
power level*angle	1	268.4	268.4	268.4	1.26	0.269
Residual Error	36	7680.8	7680.8	213.4		
Total	39	13846.7				

Unusual Observations for programming error

Obs	StdOrder	programming error	Fit	SE Fit	Residual	St Resid
1	1	100.000	71.633	7.292	28.367	2.24R
21	21	52.000	81.869	2.364	-29.869	-2.07R
29	29	45.333	79.946	2.904	-34.612	-2.42R

R denotes an observation with a large standardized residual.

Estimated Coefficients for programming error using data in uncoded units

Term	Coef
Constant	83.6120
power level	-1.19794
angle	0.0362923
power level*angle	0.00417010

The corresponding Pareto chart and radar plot are shown in the figure below. The table is useful because the significant main effects and / or interaction can be matched to the programming error results for each angle and power level.

The data clearly indicates that the power level is strongly significant in changing the programming error for all Dogbone programming environments. The angle was also significant when compared to the cut-off value, but less significant overall. This is shown in the p-value and F-statistic tables above and in the Pareto charts below. The radar plots show that as the power level increases, so does the programming error. This is true for all angles in the Dogbone Meander and Dogbone Loop programming environments. The Dogbone Skyetek programming environment had the highest programming error at all angles when compared to the other two Dogbone programming environments.

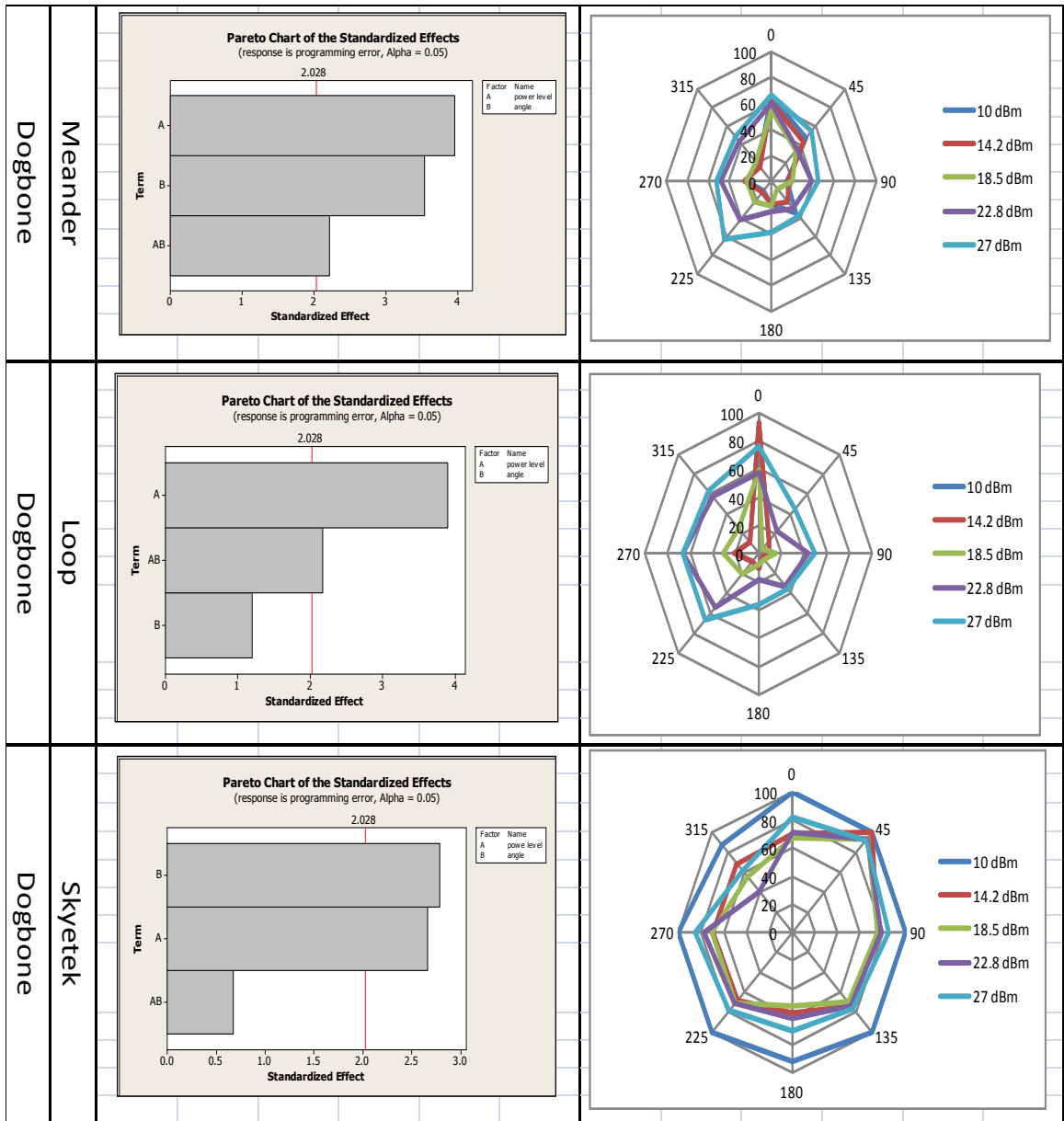
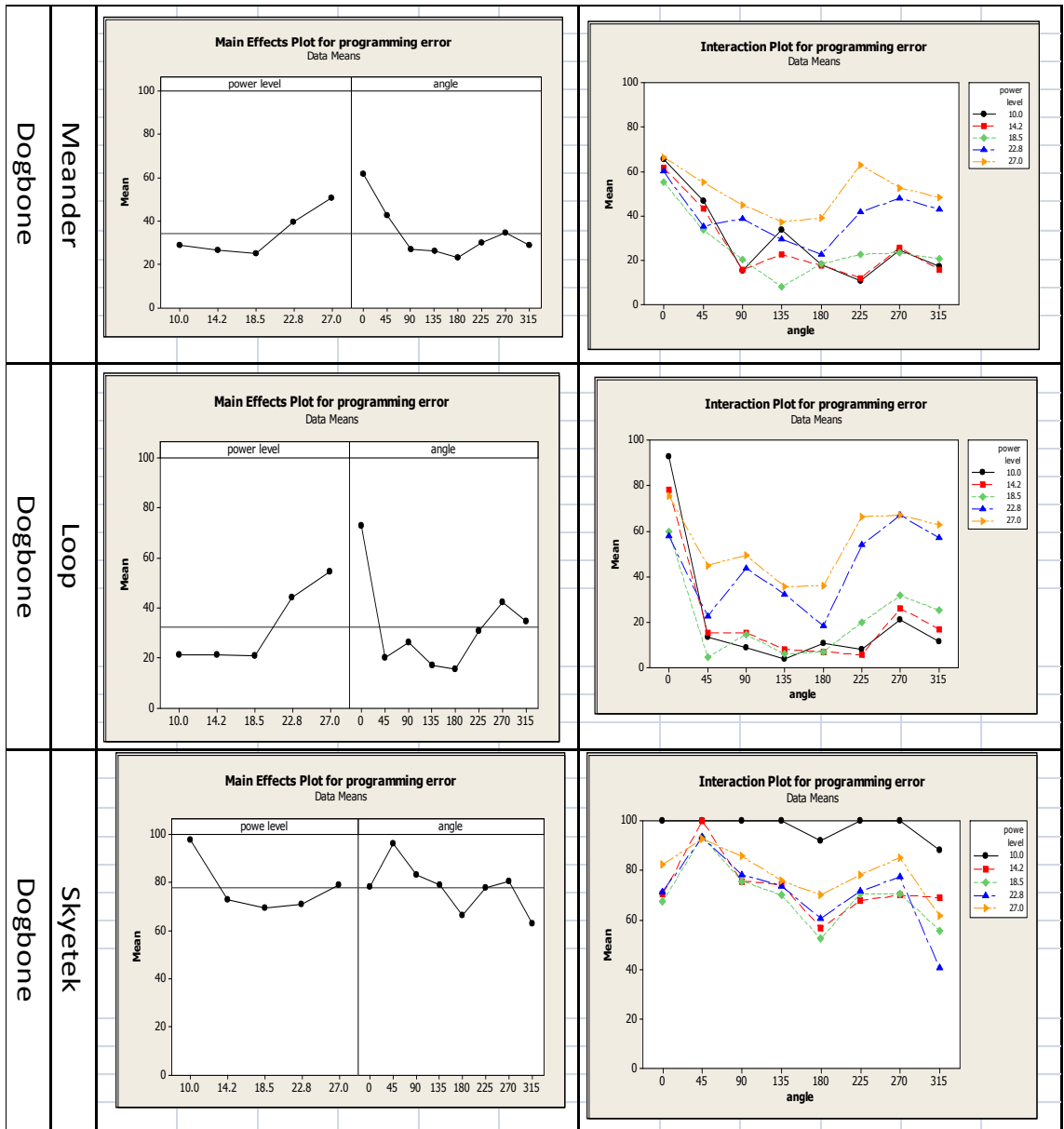


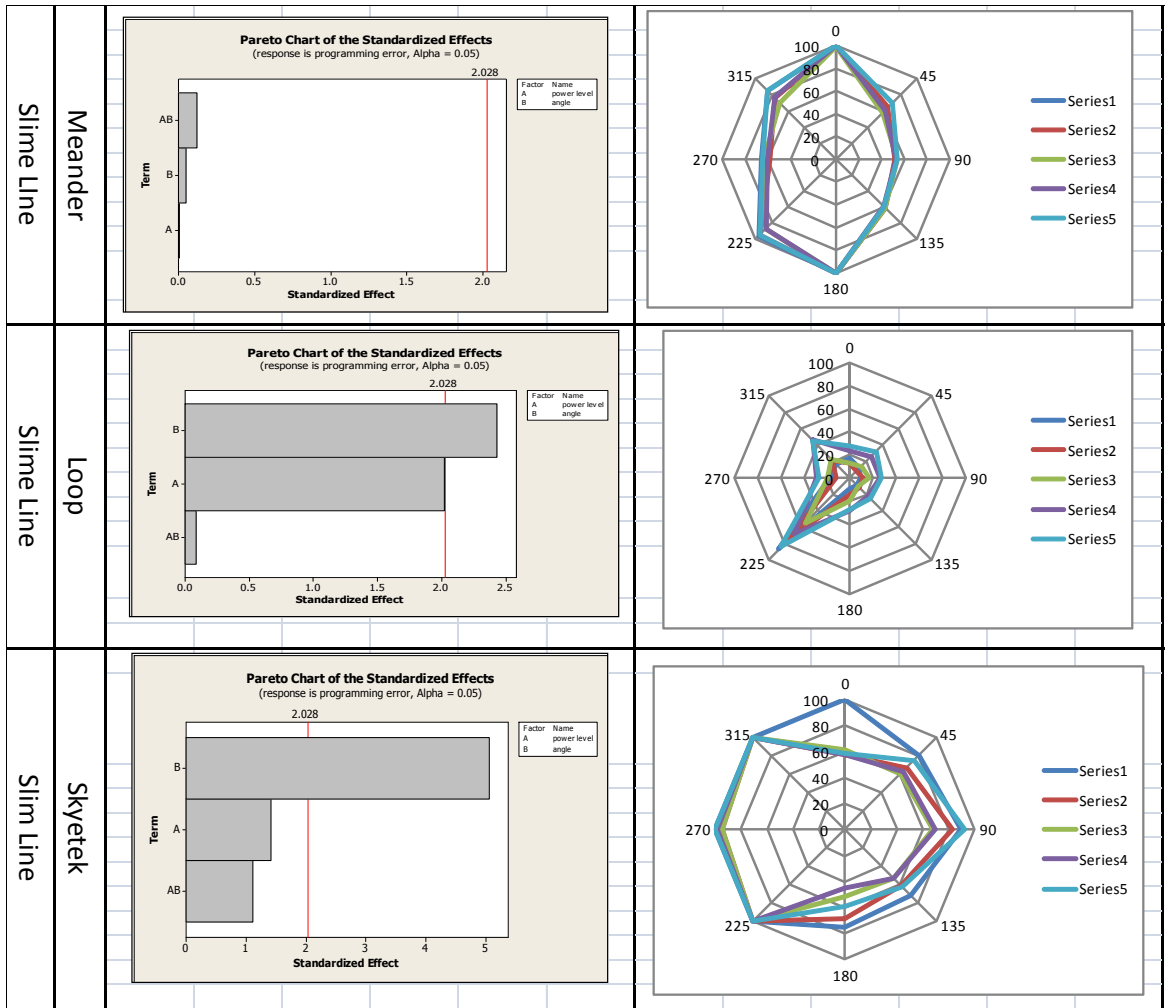
Figure 78: Dogbone Pareto charts and radar plots for all three programming environments





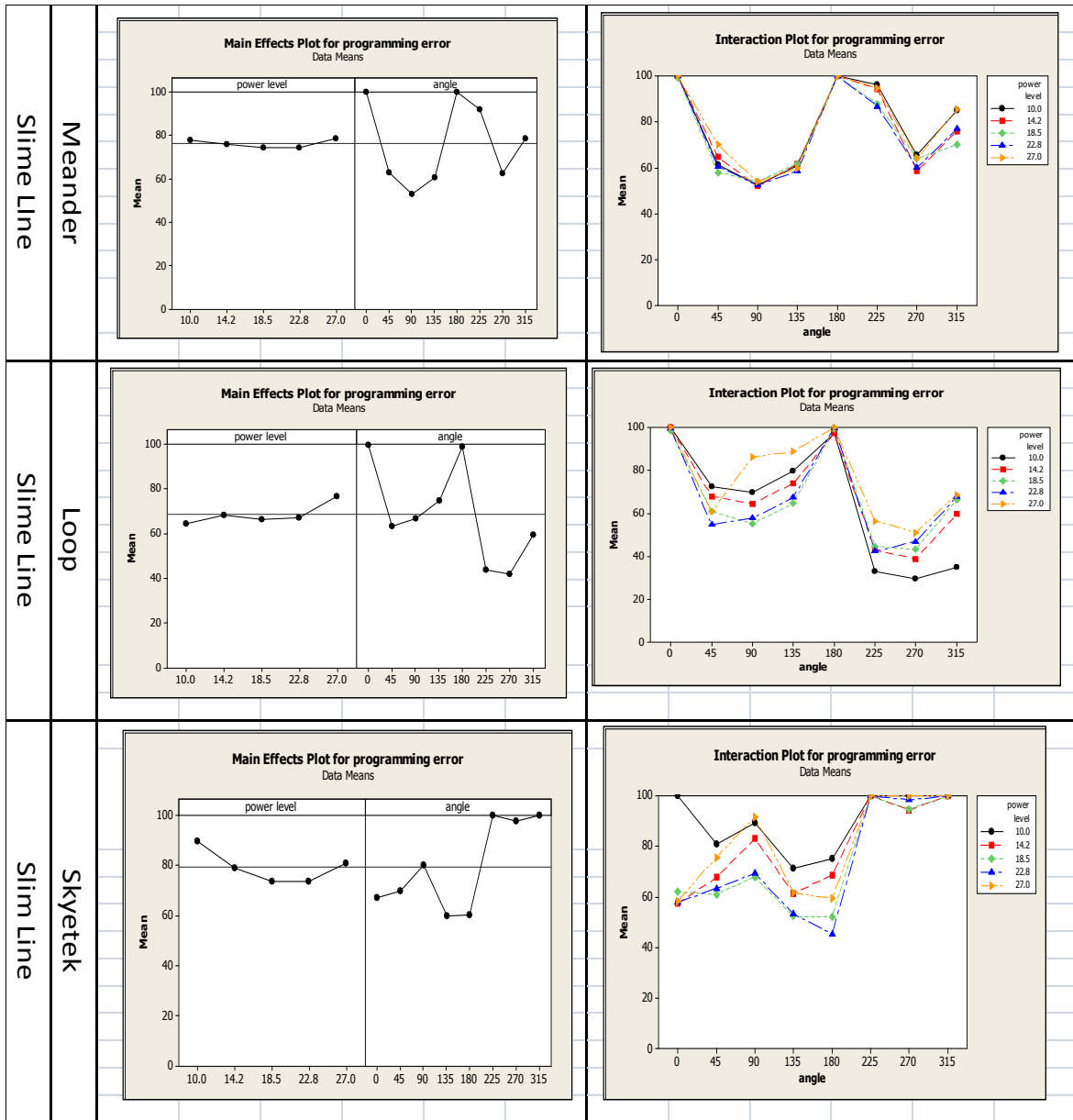
**Figure 79: Dogbone Main Effects and Interaction Plots for all three programming environments**

The results for the Slim Line were overall different compared to the Dogbone data. The angle programming factor had the most significant effect on programming error for both the Slim Line Loop and Slim Line Skyetek programming environments. The power level was not a significant programming factor. The Slim Line Meander programming environment did not indicate that power level or angle had an impact on programming error. Overall, the Slim Line programming environment had the lowest programming error, except at the 225 degree angle.



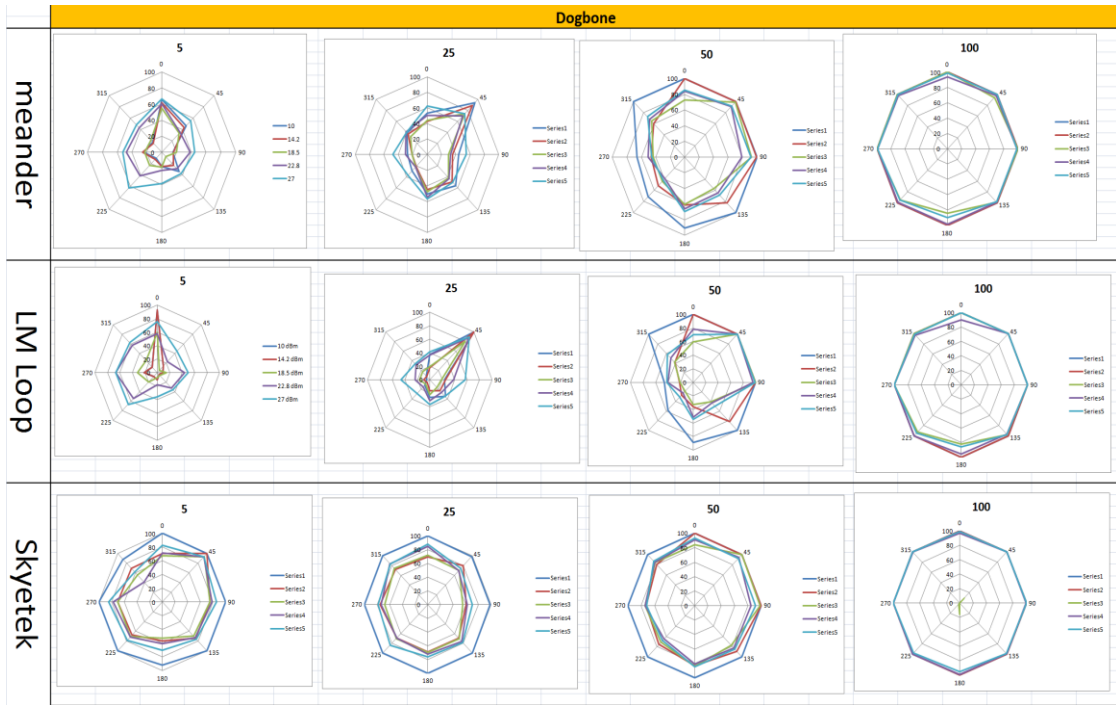
**Figure 80: Slim Line Pareto charts and radar plots for all three programming environments**

The figure below has the main effects and interaction plots for all angles and power levels (both programming factors). The plots were generated using Minitab and based upon Design of Experiments full factorial ANOVA.

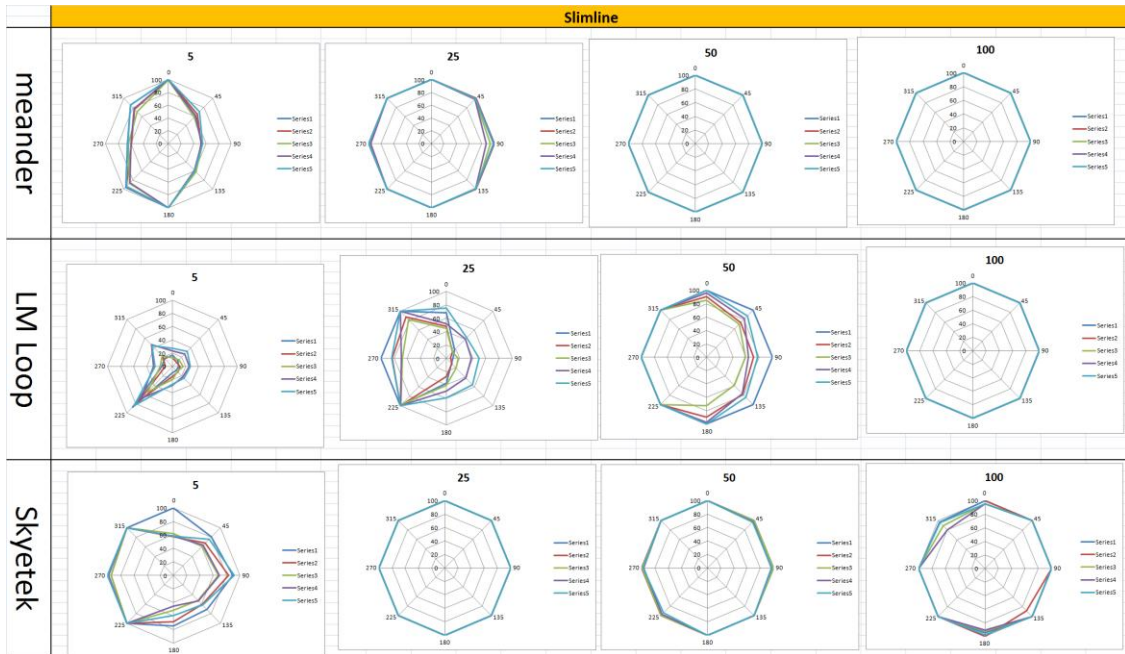


**Figure 81: Slim Line Main Effects and Interaction plots for all three programming environments**

The next two figures list the programming error radar plots for all Dogbone and Slim Line programming environments. The plots are useful in quickly comparing the programming error between programming environments.



**Figure 82 : Static Read Dogbone Programming Error Radar Plots**



**Figure 83: Static Read Slim Line Programming Error Radar Plots**

The main effects and interaction including the antenna type is listed below. The most useful chart is the antenna plot because it indicates a significant difference in programming error between antenna types. The angle and power level does show the programming error for each angle and power level regardless of tag type. The data could be misleading and the individual analysis should be the primary method.

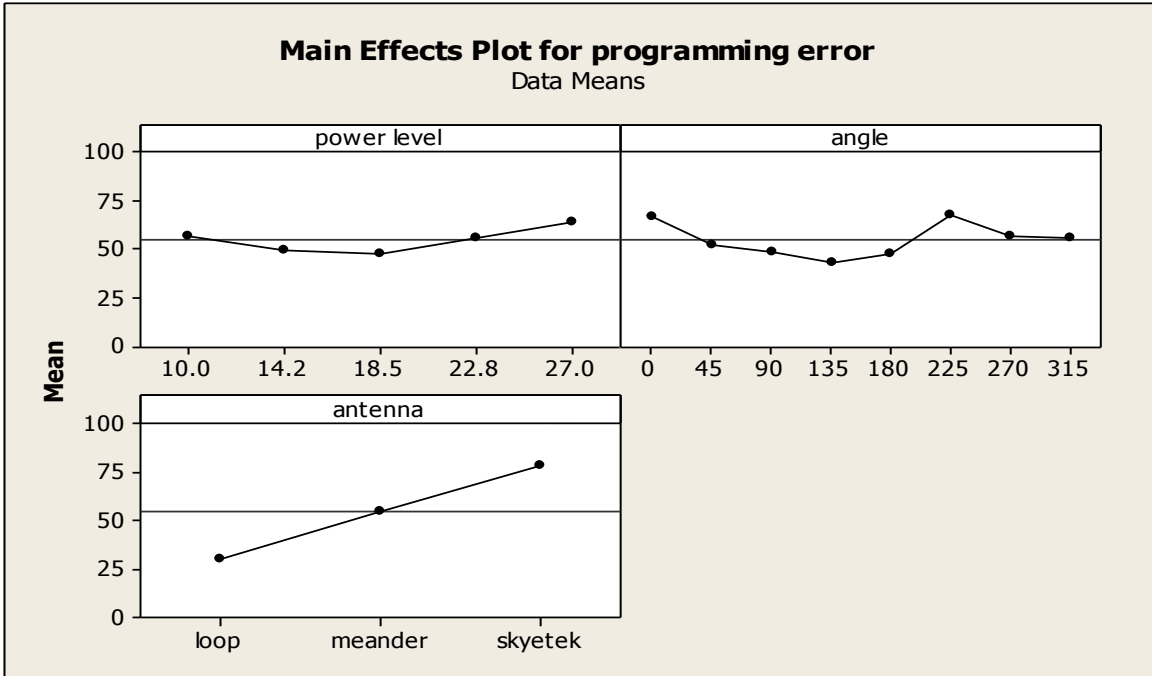


Figure 84: Static Read main effects for all tests conducted (includes both tag types)

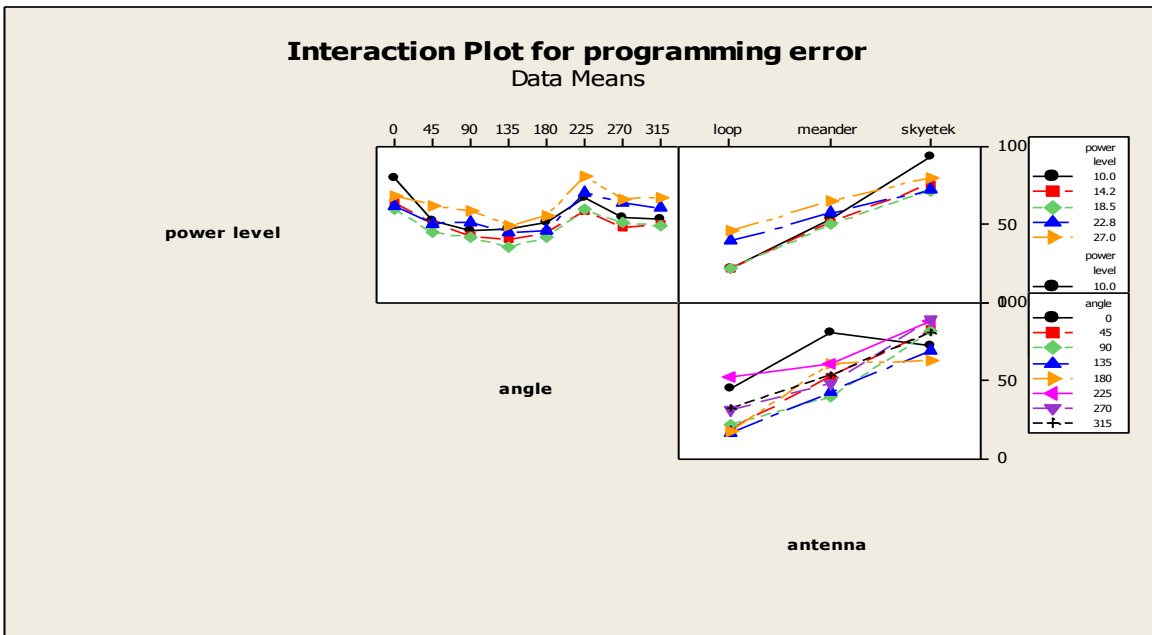


Figure 85: Static Read interaction plot for all tests conducted (includes both tag types)

### 10.2.3 Static Read Conclusion

The data clearly indicates that the power level is strongly significant in changing the programming error for all Dogbone programming environments. The angle was also significant when compared to the cut-off value, but less significant overall. This is shown in the p-value and F-statistic tables above and in the Pareto charts below. This is true for all angles in the Dogbone Meander and Dogbone Loop programming environments. The Dogbone Skyetek programming

environment had the highest programming error at all angles when compared to the other two Dogbone programming environments.

The results for the Slim Line were overall different compared to the Dogbone data. The angle programming factor had the most significant effect on programming error for both the Slim Line Loop and Slim Line Skyetek programming environments. The power level was not a significant programming factor. The Slim Line Meander programming environment did not indicate that power level or angle had an impact on programming error. Overall, the Slim Line programming environment had the lowest programming error, except at the 225 degree angle.

When comparing all the 5 mm air gap data points, the angle and power level does show the programming error for each angle and power level regardless of tag type. The data could be misleading and the individual analysis should be the primary method.

#### Dogbone Summary:

- The power level had a significant difference for all three Dogbone programming environments
- The angle had a significant difference for all three Dogbone programming environments, but less significant than the power level.
- The radar plots show that as the power level increases, so does the programming error. This is true for all angles in the Dogbone Meander and Dogbone Loop programming environments.
- The Dogbone Skyetek programming environment had the highest programming error at all angles when compared to the other two Dogbone programming environments.

#### Slim Line Summary:

- The angle programming factor had the most significant effect on programming error for both the Slim Line Loop and Slim Line Skyetek programming environments.
- The power level was not a significant programming factor. The Slim Line Meander programming environment did not indicate that power level or angle had an impact on programming error.
- Overall, the Slim Line programming environment had the lowest programming error, except at the 225 degree angle.

#### Antenna Summary:

- The Loop antenna had the lowest programming error, while Skyetek had the highest programming error.

## 10.3 Static Write



The purpose of the static write test build upon the foundation created from the static read test. Recall the three steps in programming a tag: read – write – verify. The static read tests decoupled the read from the write and verify steps. This allowed only one step to be analyzed. The static write test investigated the entire three step programming process.

It is worth noting, that when the static write data is compared the static read data, the read process is being compared to both the write – verify process. The green highlighted row in the table below represents the degrees of freedom for each programming variable and test parameter.

**Table 24: Static Write Text Matrix (green)**

	tag Types	Antenna Types	antenna angles	air gaps	power levels	Linear Distances	linear Velocities	tag sample size	treatments	Total Tests	Manual Tests	Data points
Static Read	2	3	8	4	5	1	0	3	10	28800	5760	2880000
Static Write	3	3	8	1	5	1	0	3	10	10800	2160	1080000
Static Offset 1	3	3	1	2	5	24	0	3	10	64800	12960	6480000
Static Offset 2	1	3	1	3	5	24	0	3	10	32400	6480	3240000
Dynamic	1	2	1	3	1	n/a	5	3	10	900	900	90000
												13,770,000

The static write test consisted of the most degrees of freedom (same as the static read). The purpose of the high amount of degrees of freedom is because the static read and static write test analyzes the stability of all the programming environments. The hope is that the data would be repeatable; therefore, it could be trusted.

This section discusses the test results conducted with the Dogbone, Slim Line, and Paper Clip tag and each of the three antenna types at a 5 mm air gap. A total of 720,000 data points were collected for this set of data (3 tag type x 3 tag samples x 10 replicates x 3 antenna types x 8 angles x 1 air gap x 5 power levels x 100 loops = 720,000 data points).

**Table 25: Static Write test parameters**

Tag Types	Dogbone	Slim Line	Paper Clip					
Tag Samples (treatments)	3							
Blocks	10							
Antenna Types	Meander	Loop	Skyetek					
Antenna Angles	0	45	90	135	180	225	270	315
Air Gaps	5							
Power levels	10	14.2	18.5	22.8	27			
Linear Velocity	n/a							

### 10.3.1 Statistical Analysis

The DOE 2<sup>2</sup> factorial results are listed below. The tables are the p-values and F statistic from the null hypothesis analysis. The two factors tests were: power level (P), angle (A) and the interaction between power level and angel (P\*A). The green cells indicated that the programming factor or interaction has a significant effect on the programming error. The red cells indicated that the programming factor or interaction does not have a significant effect on the programming error.

Note that the interaction between the power level and angel (P\*A) should be considered along with the individual main effects results. This is because one of the main effect values could be large and the other be small, which could result in the interaction significant.

A few inferences can be made based upon the tables:

- The angle programming factor is dominate when the Meander antenna is used regardless of tag type.
- The power level programming factor is dominate when the Loop antenna is used regardless of tag type.
- The programming factor is not constant when using the Skyetek antenna and depends on the tag type.

**Table 26: Static Read null hypothesis (p-values)**

			p-value		
			P	A	P*A
Paper Clip	Loop	5 mm	0.000	0.997	0.979
Dogbone	Meander	5 mm	0.983	0.009	0.897
Dogbone	Loop	5 mm	0.000	0.775	0.823
Dogbone	skyetek	5 mm	0.016	0.417	0.926
Slim Line	Meander	5 mm	0.614	0.0026	0.888
Slim Line	Loop	5 mm	0.000	0.561	0.82
Slim Line	skyetek	5 mm	0.284	0.000	0.189

**Table 27: Static Write null hypothesis (F-statistic)**

			F-statistic		
			P	A	P*A
Paper Clip	Loop	5 mm	117.140	0	0
Dogbone	Meander	5 mm	0	7.55	0.02
Dogbone	Loop	5 mm	77.580	0.08	0.049
Dogbone	skyetek	5 mm	6.34	0.67	0.01
Slim Line	Meander	5 mm	0.26	5.42	0.02
Slim Line	Loop	5 mm	19.920	0.34	0.049
Slim Line	skyetek	5 mm	1.18	15.860	1.8
			2.028		
			cut off value		

The statistical analysis was performed in Minitab. Below is an example data set produced from the Minitab analysis. The p-values and F-statistic are highlighted for each of the main effects, power level and angel, and the interaction between the main effects.

**Factorial Fit: Programming Error versus Power Level, Angle**

Estimated Effects and Coefficients for Programming Error (coded units)



Term	Effect	Coef	SE Coef	T	P
Constant		45.1442	1.949	23.16	0.000
Power Level	59.5259	29.7629	2.750	10.82	0.000
Angle	0.0194	0.0097	2.977	0.00	0.997
Power Level*Angle	-0.2218	-0.1109	4.201	-0.03	0.979

S = 12.3272      PRESS = 6896.53  
R-Sq = 76.49%    R-Sq(pred) = 70.36%    R-Sq(adj) = 74.53%

Analysis of Variance for Programming Error (coded units)

Source	DF	Seq SS	Adj SS	Adj MS	F	P
Main Effects	2	17800.5	17800.5	8900.3	58.57	0.000
Power Level	1	17800.5	17800.5	17800.5	117.14	0.000
Angle	1	0.0	0.0	0.0	0.00	0.997
2-Way Interactions	1	0.1	0.1	0.1	0.00	0.979
Power Level*Angle	1	0.1	0.1	0.1	0.00	0.979
Residual Error	36	5470.6	5470.6	152.0		
Total	39	23271.2				

Estimated Coefficients for Programming Error using data in uncoded units

Term	Coef
Constant	-19.8851
Power Level	3.51457
Angle	0.0015945
Power Level*Angle	-0.00008285

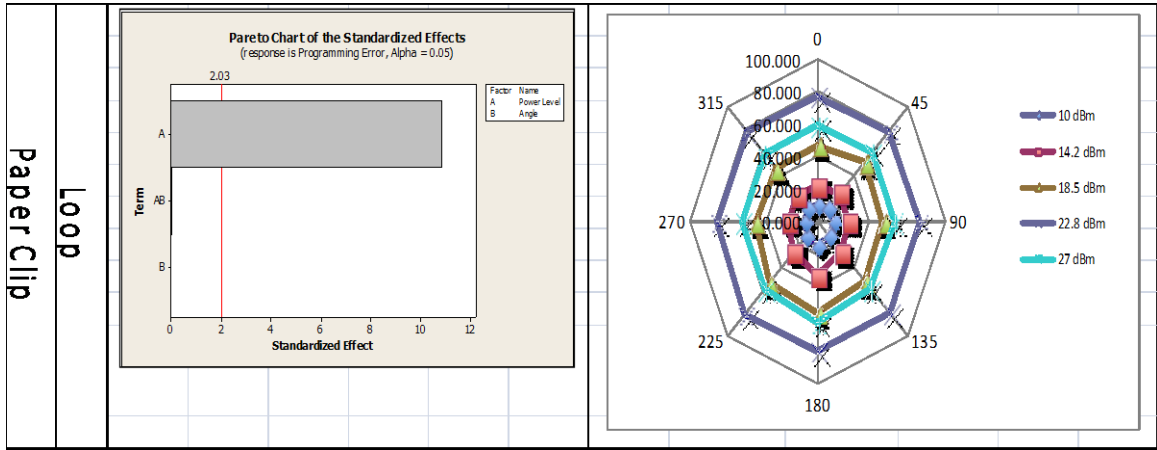
The corresponding Pareto chart and radar plot are shown in the figure below. The table is useful because the significant main effects and / or interaction can be matched to the programming error results for each angel and power level.

The data clearly indicates that the power level is strongly in changing the programming error for the Paper Clip Loop programming environments. The angle was not effective in changing the programming error. The radar plot has a circle shape for every power level tested, indicating that angle had no impact on programming error.

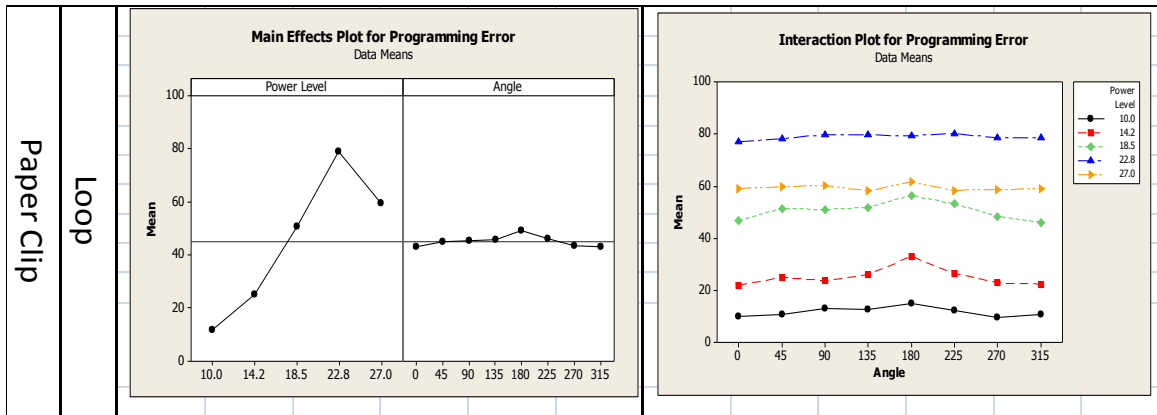
This is shown in the p-value and F-statistic tables above and in the Pareto charts below. The radar plots show that as the power level increases, so does the programming error. The 27 dBm was the only exception; it did improve compared to the 22.8 dBm power level.

The Paper Clip was not tested with the Skyetek antenna due to all results had 100% programming error. In theory, the Skyetek antenna should program the Paper Clip because both are near field antennas. The root cause is not known at this time and is part of the plan for future study.

The Paper Clip was not tested with the Meander antenna because it is a far field antenna; therefore, it cannot be programmed by the Meander antenna.



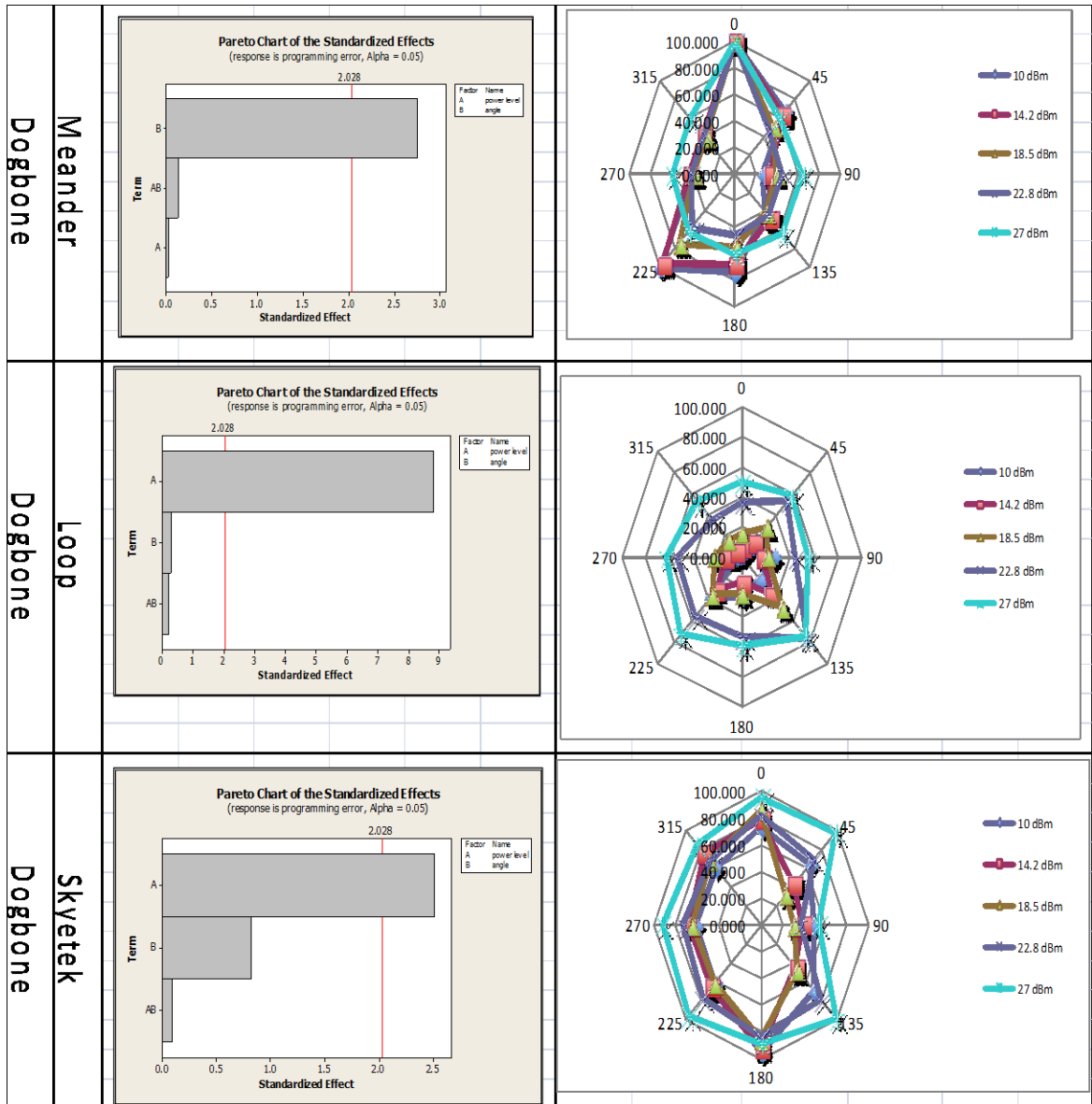
**Figure 86: Paper Clip Pareto charts and radar plots for the programming environment**



**Figure 87: Paper Clip Main Effects and Interaction plots for the programming environment**

The data is mixed with the Dogbone tag. Both the power level and angle are strongly significant in changing the programming error. The strongly significant programming factor depends on the antenna type. According to the figure below the Dogbone Meander programming environment is significantly impacted by the angle programming factor. The Dogbone Loop and Dogbone Skyetek programming environments are significantly impacted by the power level programming factor. The other programming factor was insignificant in changing the programming error in all cases.

The trend continues in that as the power level increases so does the programming error. There are a few exceptions found in the Slim Line testing, but the exceptions are not significantly different than the 22.8 dBm power level. This is shown in the p-value and F-statistic tables above and in the Pareto charts below. Overall the Dogbone Skyetek programming environment had the highest programming error at most angles when compared to the other two Dogbone programming environments. This follows the same trend found in the Paper Clip Write tests.



**Figure 88: Dogbone Pareto charts and radar plots for all three programming environments**

The figure below has the main effects and interaction plots for all angles and power levels (both programming factors). The plots were generated using Minitab and based upon Design of Experiments full factorial ANOVA

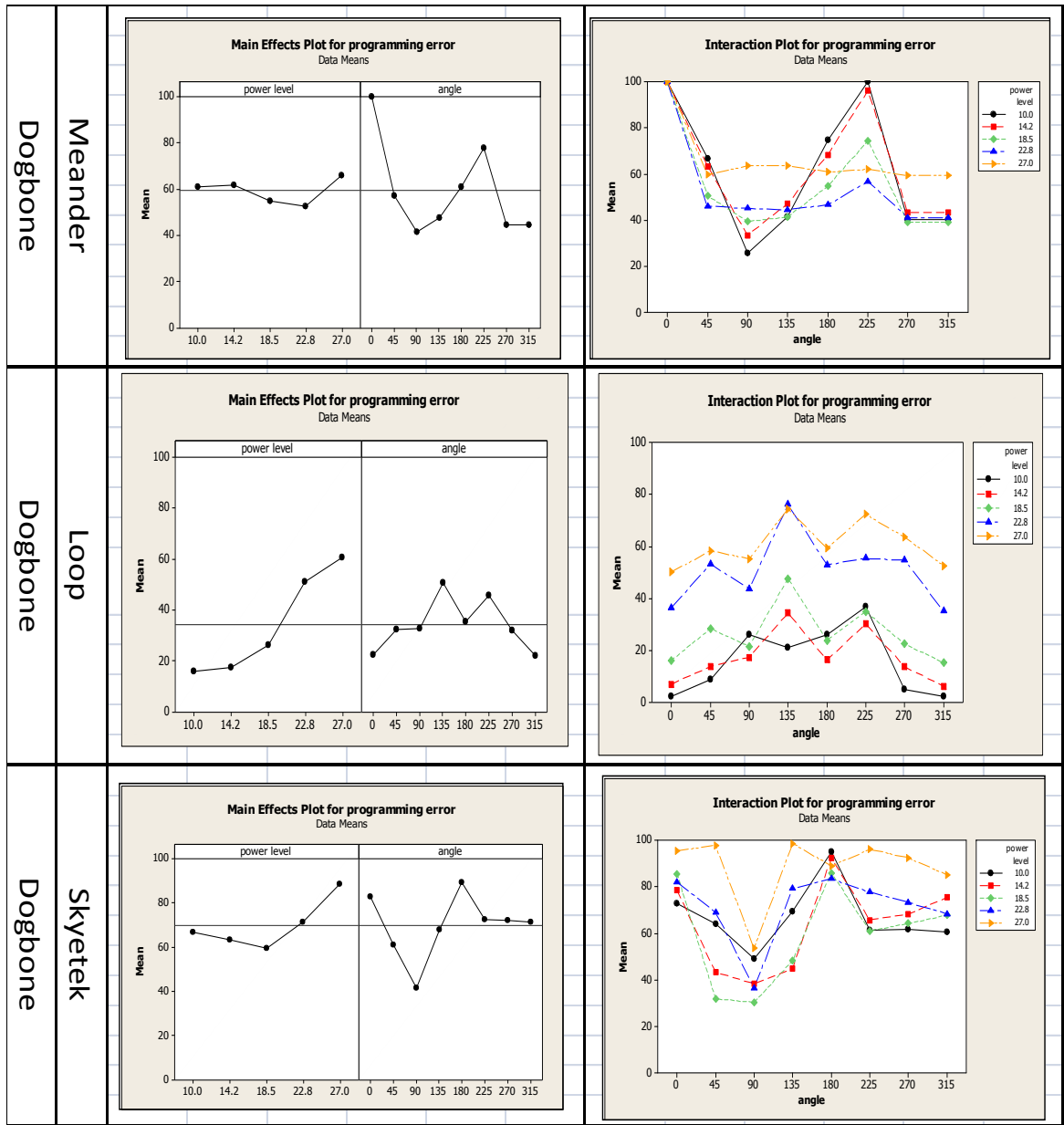
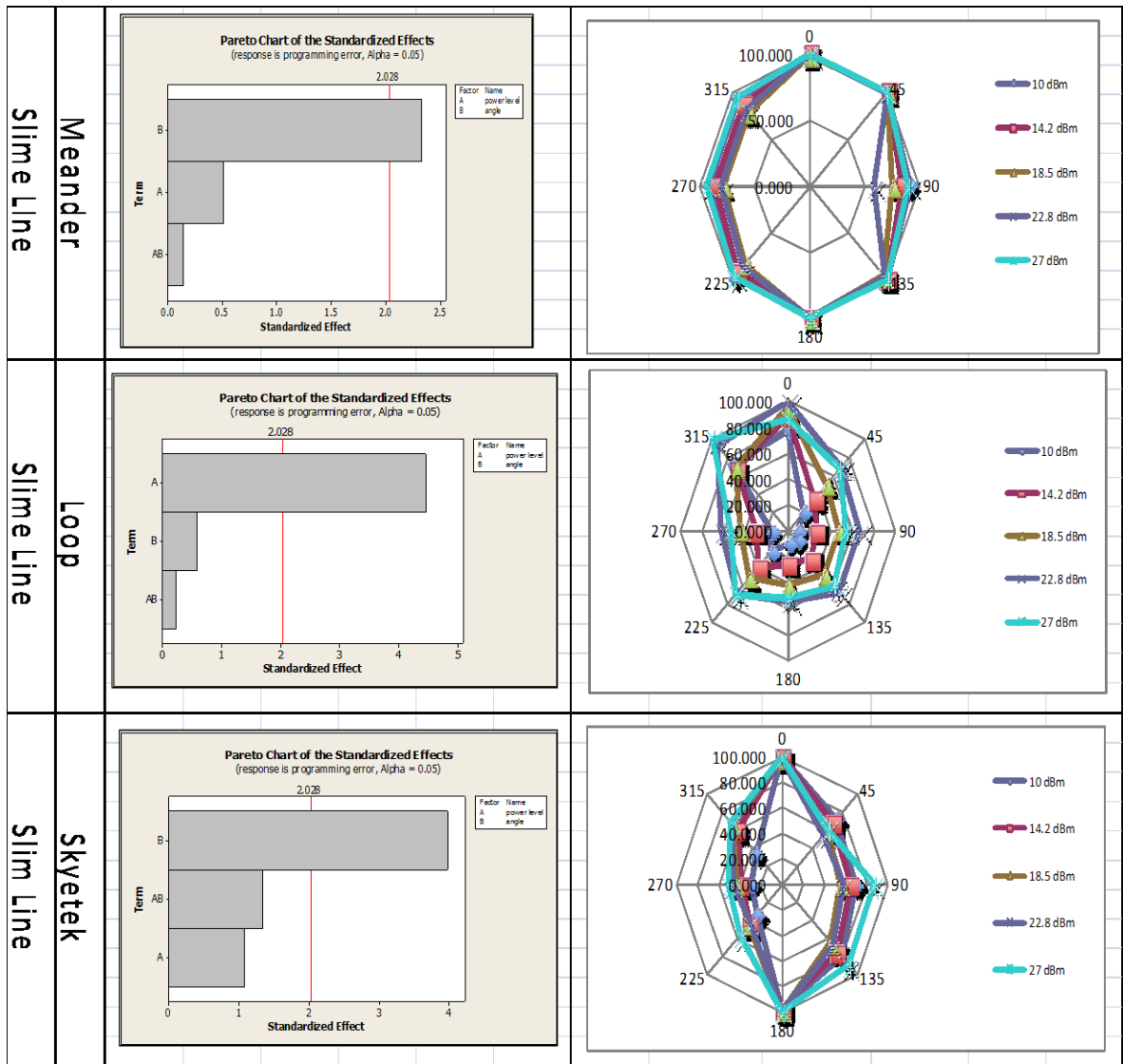


Figure 89: Dogbone Effects and Interaction plots for all three programming environments

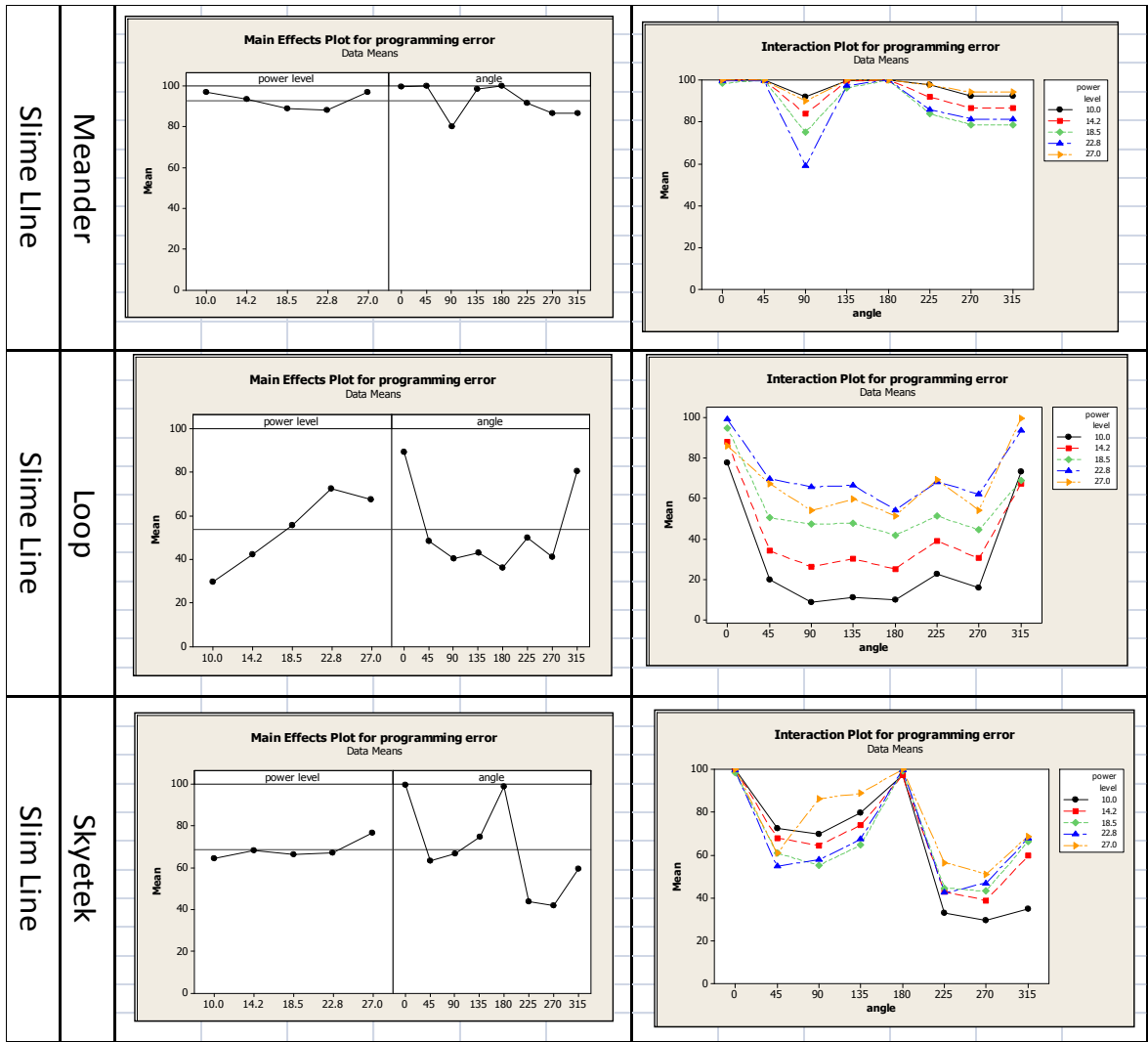
The results are similar to the Dogbone results in that the main programming factors are mixed. The Slim Line Loop programming environment is significantly impacted on the power level programming factor. The Slim Line Meander and Slim Line Skyetek programming environments are significantly impacted by the angle programming factor. The other programming factor was insignificant in changing the programming error in all cases.

The trend continues in that the as the power level increases so does the programming error. There are a few exceptions found in the Slim Line testing, but the exceptions are not significantly different than the 22.8 dBm power level. This is shown in the p-value and F-statistic tables above and in the Pareto charts below. This follows the same trend found in the Dogbone and Paper Clip Write tests.



**Figure 90: Slim Line Pareto charts and radar plots for all three programming environments**

The figure below has the main effects and interaction plots for all angles and power levels (both programming factors). The plots were generated using Minitab and based upon Design of Experiments full factorial ANOVA



**Figure 91: Slim Line Effects and Interaction plots for all three programming**

The next figure list the programming error radar plots for all Dogbone and Slim Line programming environments. The plots are useful in quickly comparing the programming error between programming environments.

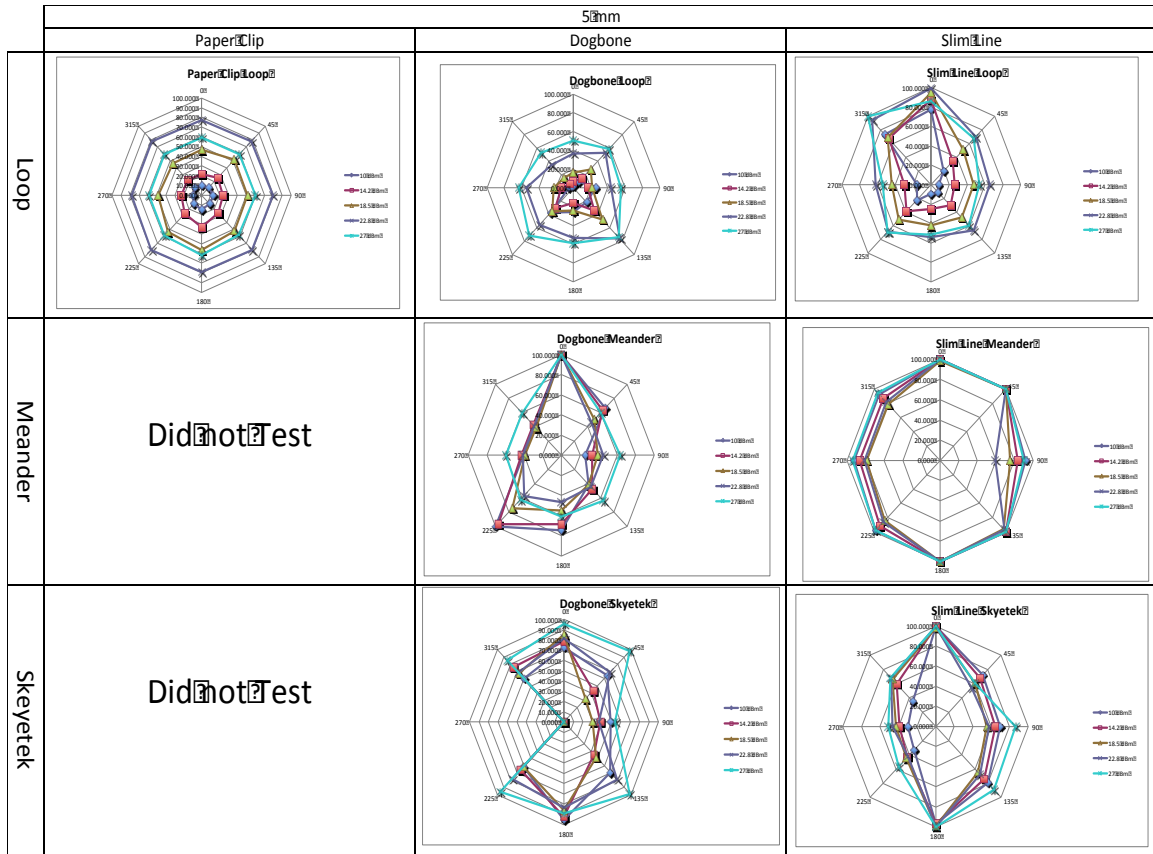


Figure 92: Static Write 5 mm air gap radar plot summary

### 10.3.2 Static Write Conclusion

The data clearly indicates that the power level is strongly in changing the programming error for the Paper Clip Loop programming environments. The angle was not effective in changing the programming error. The radar plot has a circle shape for every power level tested, indicating that angle had no impact on programming error.

The radar plot shows that as the power level increases, so does the programming error. The 27 dBm was the only exception; it did improve compared to the 22.8 dBm power level.

The Paper Clip was not tested with the Skyetek antenna due to all results had 100% programming error. In theory, the Skyetek antenna should program the Paper Clip because both are near field antennas. The root cause is not known at this time and is part of the plan for future study.

The Paper Clip was not tested with the Meander antenna because it is a far field antenna; therefore, it cannot be programmed by the Meander antenna.

The data is mixed with the Dogbone tag. Both the power level and angle are strongly significant in changing the programming error. The strongly significant programming factor depends on the antenna type. The Dogbone Meander programming environment is significantly impacted by the angle programming factor. The Dogbone Loop and Dogbone Skyetek programming environments are significantly impacted by the power level programming factor. The other programming factor was insignificant in changing the programming error in all cases.

The trend continues in that the as the power level increases so does the programming error. There are a few exceptions found in the Slim Line testing, but the exceptions are not significantly different than the 22.8 dBm power level. This is shown in the p-value and F-statistic tables and in the Pareto charts. Overall the Dogbone Skyetek programming environment had the highest programming error at most angles when compared to the other two Dogbone programming environments. This follows the same trend found in the Paper Clip Write tests.

The Slim Line results were similar to the Dogbone results in that the main programming factors are mixed. The Slim Line Loop programming environment is significantly impacted on the power level programming factor. The Slim Line Meander and Slim Line Skyetek programming environments are significantly impacted by the angle programming factor. The other programming factor was insignificant in changing the programming error in all cases.

The trend continues in that the as the power level increases so does the programming error. There are a few exceptions found in the Slim Line testing, but the exceptions are not significantly different than the 22.8 dBm power level. This is shown in the p-value and F-statistic tables and in the Pareto charts. This follows the same trend found in the Dogbone and Paper Clip Write tests.

#### Paperclip Summary:

- The power level had a significant difference for Paperclip Loop programming environment.
- The angle was not effective in changing the programming error.
- As the power level increases, so does the programming error
- The Paper Clip was not tested with the Skyetek antenna due to all results had 100% programming error. In theory, the Skyetek antenna should program the Paper Clip because both are near field antennas.
- The Paper Clip was not tested with the Meander antenna because it is a far field antenna; therefore, it cannot be programmed by the Meander antenna.

#### Dogbone Summary:

- Both the power level and angle are strongly significant in changing the programming error.
- The strongly significant programming factor depends on the antenna type.
- The Dogbone Meander programming environment is significantly impacted by the angle programming factor.
- The Dogbone Loop and Dogbone Skyetek programming environments are significantly impacted by the power level programming factor.
- The other programming factor was insignificant in changing the programming error in all cases.
- As the power level increases so does the programming error (for most data point comparisons).
- Overall the Dogbone Skyetek programming environment had the highest programming error at most angles when compared to the other two Dogbone programming environments. This follows the same trend found in the Paper Clip Write tests.

#### Slim Line Summary:

- Both the power level and angle are strongly significant in changing the programming error.
- The Slim Line Loop programming environment is significantly impacted on the power level programming factor.



- The Slim Line Meander and Slim Line Skyetek programming environments are significantly impacted by the angle programming factor.
- The other programming factor was insignificant in changing the programming error in all cases.
- As the power level increases so does the programming error (for most data point comparisons).

Antenna Summary:

- A few inferences can be made based upon the tables:
  - The *angle* programming factor is dominate when the Meander antenna is used regardless of tag type.
  - The *power level* programming factor is dominate when the Loop antenna is used regardless of tag type.
  - The programming factor is not constant when using the Skyetek antenna and depends on the tag type.

### 10.3.3 Static Read and Static Write Comparison

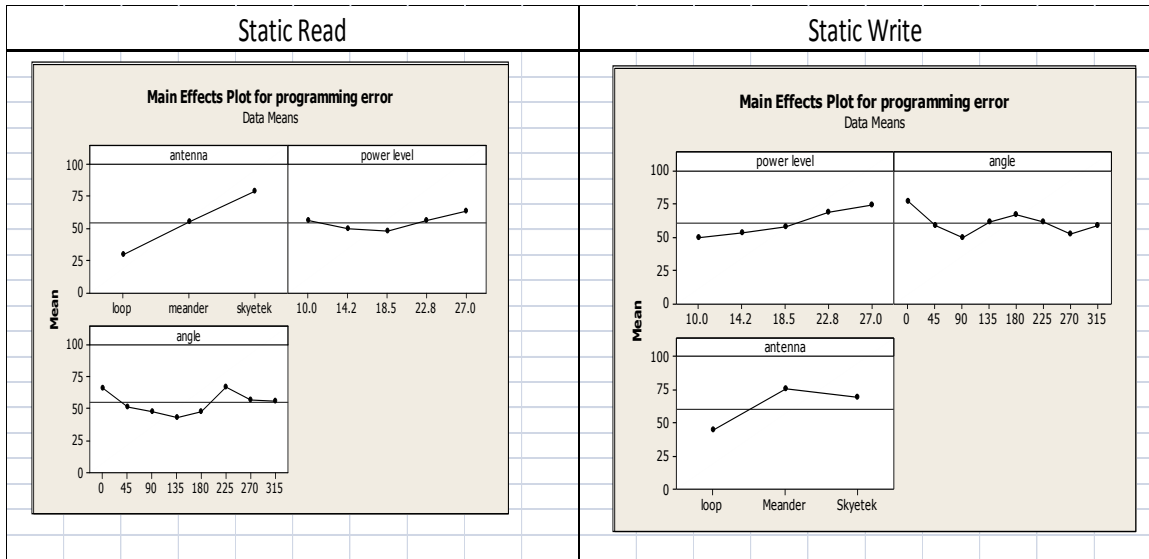
The significant programming factors for the static read are a combination of power level and angle. There is a shift from a combination of two significant programming factors to one. The static write test clearly shows one significant programming factor per programming environment. Further work will be required to help explain why the static read and static write significant programming factors can possibly be different.

			Static Read			Static Write		
			p-value			p-value		
			P	A	P*A	P	A	P*A
Paper Clip	Loop	5 mm	n/a	n/a	n/a	0.000	0.997	0.979
Dogbone	Loop	5 mm	0.000	0.238	0.036	0.000	0.775	0.823
Slim Line	Loop	5 mm	0.049	0.02	0.933	0.000	0.561	0.82
Dogbone	skyetek	5 mm	0.012	0.009	0.502	0.016	0.417	0.926
Slim Line	skyetek	5 mm	0.167	0.000	0.269	0.284	0.000	0.189
Dogbone	Meander	5 mm	0.000	0.001	0.033	0.983	0.009	0.897
Slim Line	Meander	5 mm	0.998	0.959	0.903	0.614	0.0026	0.888
			Static Read			Static Write		
			F-value			F-value		
			P	A	P*A	P	A	P*A
Paper Clip	Loop	5 mm	n/a	n/a	n/a	117.140	0	0
Dogbone	Loop	5 mm	15.230	1.44	4.75	77.580	0.08	0.049
Slim Line	Loop	5 mm	4.090	5.92	0.01	19.920	0.34	0.049
Dogbone	skyetek	5 mm	7.07	7.74	0.46	6.34	0.67	0.01
Slim Line	skyetek	5 mm	1.99	25.650	1.26	1.18	15.860	1.8
Dogbone	Meander	5 mm	15.71	12.55	4.95	0	7.55	0.02
Slim Line	Meander	5 mm	0.00	0.00	0.02	0.26	5.42	0.02
			2.028			2.028		
			cut off value			cut off value		

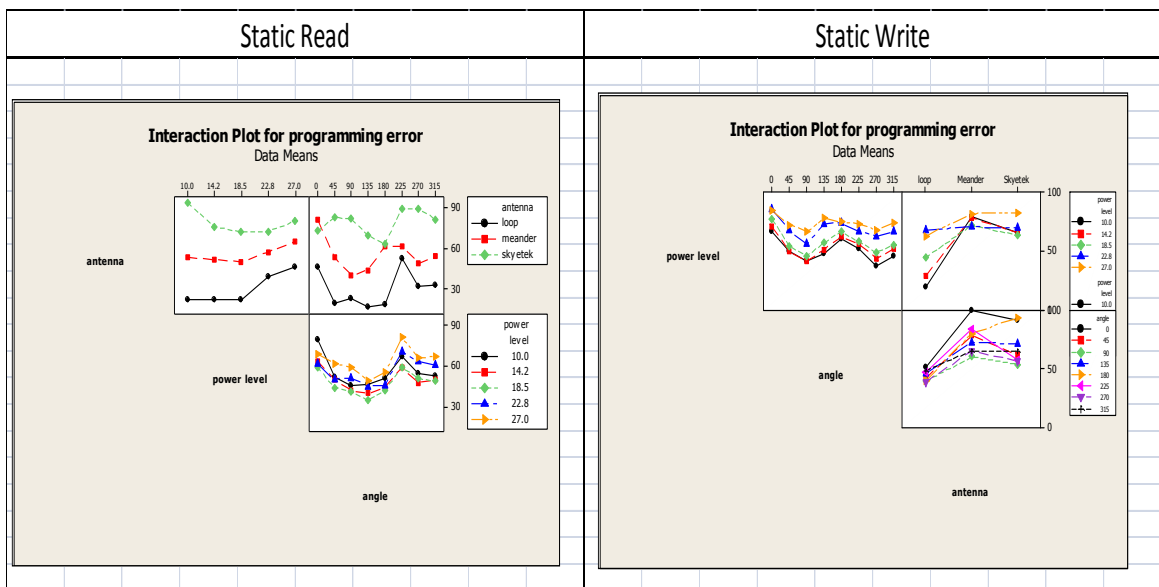
**Figure 93: Static read and static write DOE results (p-values and calculated F-statistic)**

The next two figures are the main effects and interaction plots from the DOE analysis. They can be used to make the following inferences:

- The Loop antenna is the best performer and the Skyetek is the worst performer based on programming error in the static read test. The Loop antenna is the best performed in the static write, but the Meander and Skyetek antennas are similar in programming error.
- The power level decreases the programming error from 10 dBm to 18.5 dBm and then increases the programming error from 18.5 dBm to 27.0 dBm in the static read. The programming error increases at a constant rate of change as the power level increases for the static write (from 10 dBm to 27 dBm)
- The angle programming response is similar in both the static read and static write tests.

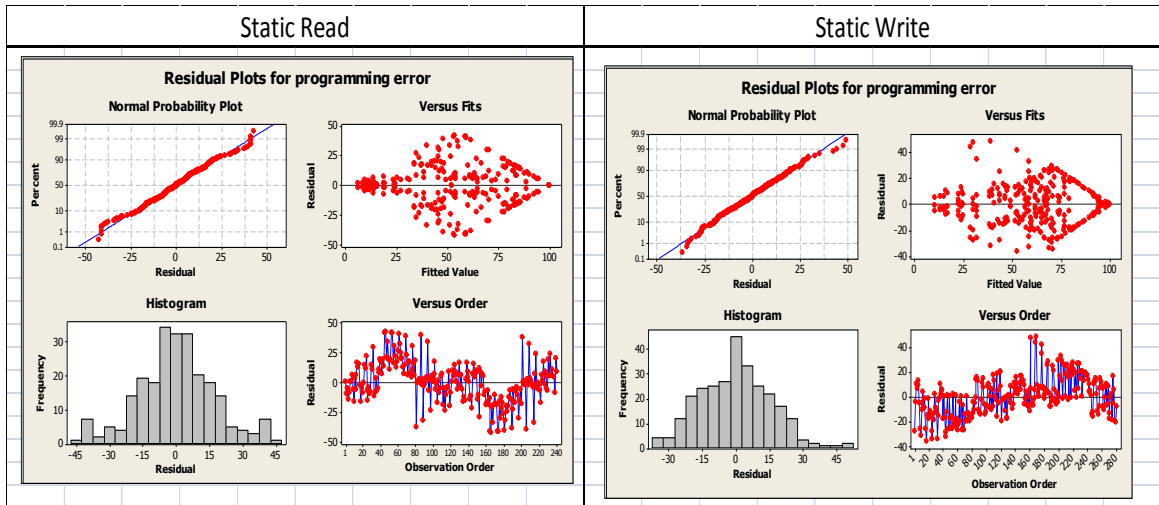


**Figure 94: Static read and write main effects DOE plot**



**Figure 95: Static read and write interaction DOE plot**

The charts below normal probability, distribution, fitted value and observation for both the static read and static write tests. The charts show that the assumptions for the statistical model are not clearly violated.



**Figure 96: Static read and write residual plots from the DOE analysis**

The next two plots are the main effects and the interaction plots for all static read and static write tests. Below are the inferences made from the analysis:

- No significant difference between test types (p-value = 0.682).
- A significant difference between the Slim Line and the other two tags (p-value = 0.032).
- A significant difference between the Loop antenna and the other two antennas types (p-value = 0.0165).
- No significant difference between power levels and programming error (p-value = 0.743)
- No significant difference between angle and programming error (p-value = 0.139)

# Static Read and Static Write

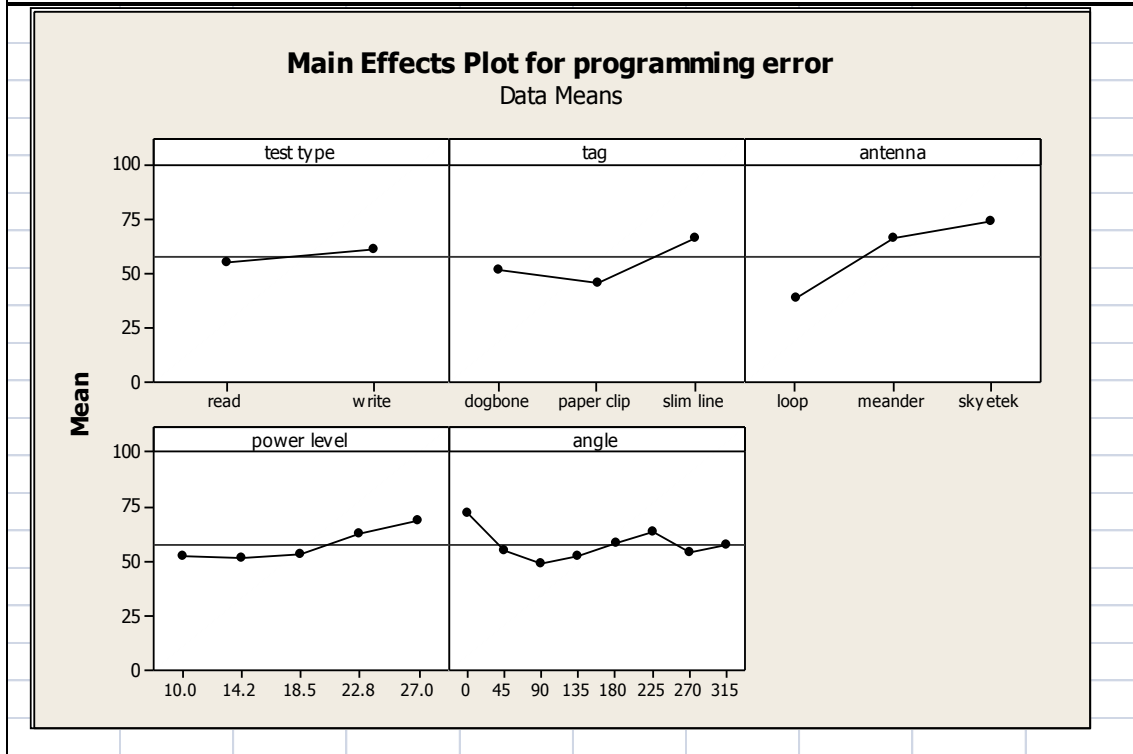


Figure 97: Static read and write combine main effects DOE plot

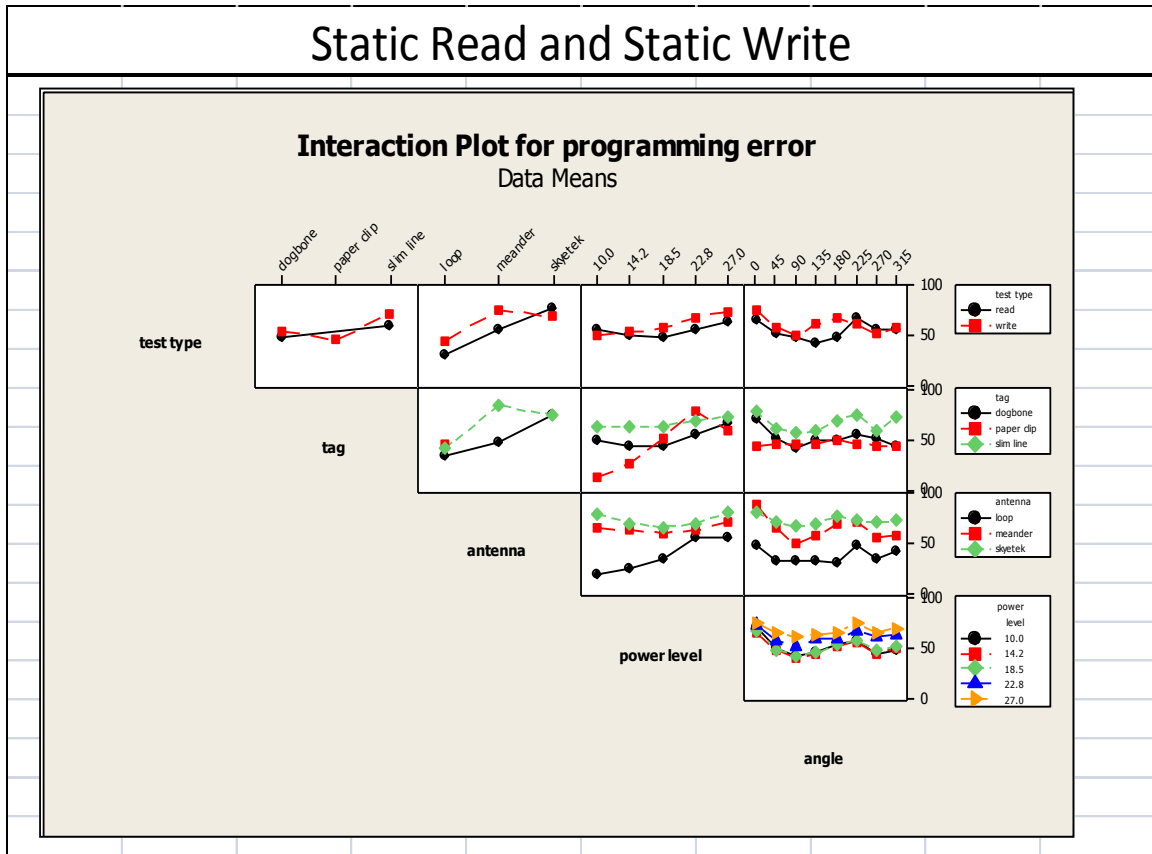


Figure 98: Static read and write interaction DOE plots

#### 10.3.4 Static read and Static write comparison conclusion

The significant programming factors for the static read are a combination of power level and angle. There is a shift from a combination of two significant programming factors to one. The static write test clearly shows one significant programming factor per programming environment. Further work will be required to help explain why the static read and static write significant programming factors can possibly be different.

Below are the inferences made from statistical analysis comparing the overall static read and static write separately:

- The Loop antenna is the best performer and the Skyetek is the worst performer based on programming error in the static read test. The Loop antenna is the best performed in the static write, but the Meander and Skyetek antennas are similar in programming error.
- The power level decreases the programming error from 10 dBm to 18.5 dBm and then increases the programming error from 18.5 dBm to 27.0 dBm in the static read. The programming error increases at a constant rate of change as the power level increases for the static write (from 10 dBm to 27 dBm)
- The angle programming response is similar in both the static read and static write tests.

Below are the inferences made from statistical analysis comparing the overall static read and static write combined:

- No significant difference between test types (p-value = 0.682).

- A significant difference between the Slim Line and the other two tags (p-value = 0.032).
- A significant difference between the Loop antenna and the other two antennas types (p-value = 0.0165).
- No significant difference between power levels and programming error (p-value = 0.743)
- No significant difference between angle and programming error (p-value = 0.139)

## 10.4 Static Offset



The purpose of the static offset test is to define the length of the programming window for specified RFID programming systems. This was the last fundamental step before the dynamic testing was performed. This is because the static offset test decouples the optimal programming window by defining it independent of linear speed.

The testing degrees of freedom were reduced because only the optimal angles were tested. The test initially began with three tag types, two optimal angles, three antennas types, three air gaps and 5 power levels. The offset tests were conducted every 1 cm from the nominal tag position (i.e. nominal tag position is when the tag IC is aligned with the antenna center, which is the same tag position as the static read and static write). The test is highlighted in green below.

**Table 28: Static offset test matrix (full – green) and reduced (orange)**

	tag Types	Antenna Types	antenna angles	air gaps	power levels	Linear Distances	linear Velocities	tag sample size	treatments	Total Tests	Manual Tests	Data points
Static Read	2	3	8	4	5	1	0	3	10	28800	5760	2880000
Static Write	3	3	8	1	5	1	0	3	10	10800	2160	1080000
Static Offset 1	3	3	1	2	5	24	0	3	10	64800	12960	6480000
Static Offset 2	1	3	1	3	5	24	0	3	10	32400	6480	3240000
Dynamic	1	2	1	3	1	n/a	5	3	10	900	900	90000
												13,770,000

The preliminary results indicated that the Slim Line were the least optimal tags, which brought the Dogbone tag into the main focus. The data also indicated that the two optimal angles produced similar results; therefore, only one optimal angle is required. Reducing the degrees of freedom by three decreased the total number of possible data points by half. The table above has the full (green) and reduced test matrix (orange).

### 10.4.1 Test Parameters

The static offset reduced test focused on the Dogbone tag with various programming environments. This section discusses the test results conducted with the Dogbone tag and each of the three antenna types at a 5 mm 25 mm and 50 mm air gap. A total of 324,00 data points were

collected for this set of data (1 tag type x 3 tag samples x 10 replicates x 3 antenna types x 1 angles x 3 air gap x 5 power levels x 24 offset distances x 100 loops = 324,000 data points).

**Table 29: Static offset test parameters**

Tag Types	Dogbone						
Tag Samples (treatments)	3						
Blocks	10						
Antenna Types	Meander	Loop	Skyetek				
Antenna Angles	Optimal angel for each tag type						
Air Gaps	5	25	50				
Power levels	10	14.2	18.5	22.8	27		
Offset Distances	24	1 cm increments					
Linear Velocity	n/a						

The optimal programming angles for the Dogbone were 90 and 270°. This was based on the results from the static read and static write tests. See figure 77, 86, and 87 for Dogbone test results.

#### 10.4.2 Statistical Analysis

The DOE 2<sup>2</sup> factorial results are listed below. The tables are the p-values and F statistic from the null hypothesis analysis. The two factors tests were: power level (P), offset distance (D) and the interaction between power level and angel (P\*D). The green cells indicated that the programming factor or interaction has a significant effect on the programming error. The red cells indicated that the programming factor or interaction that did not have a significant effect on the programming error.

Note that the interaction between the power level and offset distance (P\*D) should be considered along with the individual main effects results. This is because one of the main effect values could be large and the other be small, which could result in the interaction significant.

A few inferences can be made based upon the tables:

- The *power level* programming factor was significant in changing the programming error in all Dogbone Loop programming environments.
- The *power level* programming factor was not significant in the two Skyetek programming environments.
- The *power level* programming factor was significant at the Meander - 50mm air gap. It was less significant to not significant at lower air gaps.
- The *offset distance* programming factor was not dominate in any of the programming environments. This was analyses by comparing the last point where the programming error was not zero and the nominal position.
- Both optimal programming *angles*, 90° and 270°, produced the same statistical results.



**Table 30: Static Offset null hypothesis (90 degree)**

	p-value			F-statistic		
	P	D	P*D	P	D	P*D
Dogbone Loop 5mm 90 deg	0.000	0.986	0.557	22.79	0.00	0.35
Dogbone Loop 25mm 90 deg	0.000	0.908	0.869	22.1	0.01	0.3
Dogbone Loop 50mm 90 deg	0.023	0.508	0.795	5.43	0.44	0.07
Dogbone Skyetek 5 mm 90 deg	0.696	0.289	0.741	0.15	1.14	0.11
Dogbone Meander 5 mm 90 deg	0.835	0.368	0.919	0.04	0.83	0.01
Dogbone Meander 25 mm 90 deg	0.064	0.35	0.557	3.55	0.89	0.35
Dogbone Meander 50 mm 90 deg	0.001	0.505	0.482	11.06	0.45	0.5
				2.00	cut off value	

**Table 31: Static offset null hypothesis (90 and 270 deg)**

	p-value			F-statistic		
	P	D	P*D	P	D	P*D
Dogbone Loop 5mm 90 deg	0.000	0.986	0.557	22.79	0.00	0.35
Dogbone Loop 5mm 270 deg	0.000	0.39	0.308	21.54	0.74	1.05
Dogbone Loop 25mm 90 deg	0.000	0.908	0.869	22.1	0.01	0.3
Dogbone Loop 25mm 270 deg	0.000	0.786	0.578	18.15	0.07	0.31
Dogbone Loop 50mm 90 deg	0.023	0.508	0.795	5.43	0.44	0.07
Dogbone Skyetek 5 mm 90 deg	0.696	0.289	0.741	0.15	1.14	0.11
Dogbone Skyetek 5 mm 270 deg	0.891	0.663	0.846	0.02	0.19	0.04
Dogbone Meander 5 mm 90 deg	0.835	0.368	0.919	0.04	0.83	0.01
Dogbone Meander 5 mm 270 deg	0.774	0.067	0.966	0.08	3.54	0.00
Dogbone Meander 25 mm 90 deg	0.064	0.35	0.557	3.55	0.89	0.35
Dogbone Meander 50 mm 90 deg	0.001	0.505	0.482	11.06	0.45	0.5
				2.00	cut off value	

Note that two cells in the F-statistic are identified as significant and the same cells in the p-value table are not. Even with the F-statistic is close to the 2.0 cut off value and the P-value is close to the 0.05 cut off value, the relationship is significantly weak to no relationship.

The statistical analysis was performed in Minitab. Below is an example data set produced from the Minitab analysis. The p-values and F-statistic are highlighted for each of the main effects, power level and angel, and the interaction between the main effects.

**Factorial Fit: programming error versus power level, offset distance**

Estimated Effects and Coefficients for programming error (coded units)

Term	Effect	Coef	SE Coef	T	P
Constant		0.37171	0.03846	9.66	0.000
power level	0.25295	0.12648	0.05426	2.33	0.023
offset distance	-0.03204	-0.01602	0.02406	-0.67	0.508
power level*offset distance	0.01774	0.00887	0.03394	0.26	0.795

S = 0.241924      PRESS = 3.95604  
R-Sq = 14.96%      R-Sq(pred) = 5.77%      R-Sq(adj) = 10.78%

Analysis of Variance for programming error (coded units)

Source	DF	Seq SS	Adj SS	Adj MS	F	P
Main Effects	2	0.62413	0.34389	0.171947	2.94	0.061
power level	1	0.59817	0.31794	0.317939	5.43	0.023
offset distance	1	0.02596	0.02596	0.025956	0.44	0.508
2-Way Interactions	1	0.00400	0.00400	0.003997	0.07	0.795
power level*offset distance	1	0.00400	0.00400	0.003997	0.07	0.795
Residual Error	61	3.57016	3.57016	0.058527		
Total	64	4.19828				

Unusual Observations for programming error  
programming

Obs	StdOrder	error	Fit	SE Fit	Residual	St Resid
17	17	0.853333	0.307733	0.047253	0.545601	2.30R
18	18	0.796667	0.300896	0.041802	0.495770	2.08R
22	22	0.776667	0.273550	0.041802	0.503117	2.11R
59	59	0.000000	0.491038	0.051892	-0.491038	-2.08R

R denotes an observation with a large standardized residual.

Estimated Coefficients for programming error using data in uncoded units

Term	Coef
Constant	0.0611156
power level	0.0159231
offset distance	-0.00058882
power level*offset distance	1.73941E-05

Dogbone – Loop Environment Inferences

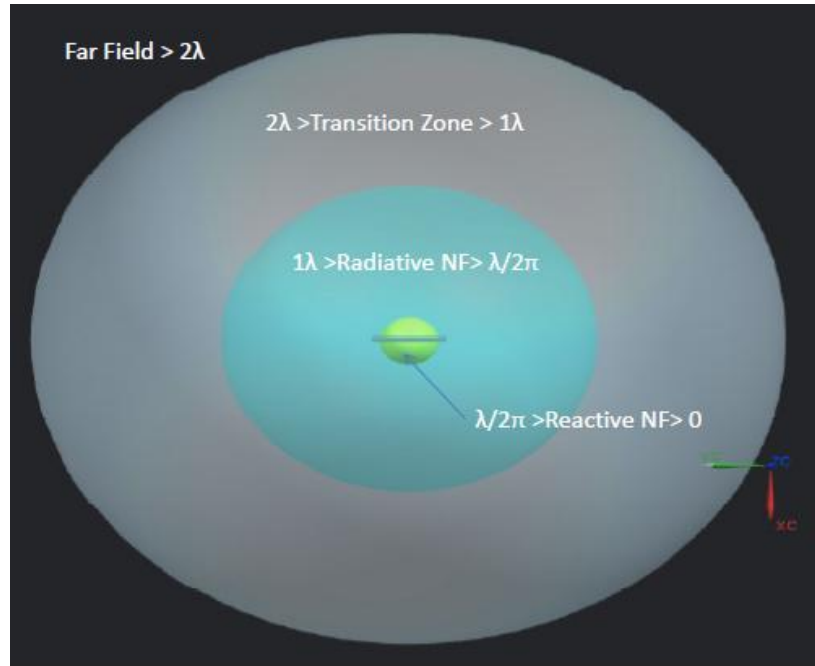
- The programming window with 55% to 10% programming occurs between -80 mm to 80 mm. A total length of 160mm centered on 0.
- The programming error decreases as the tag approach 0. Or the programming error increases as the tag moves from 0.
- Both optimal programming angles perform similar. No significant difference.
- The length of the programming window is similar at the air gaps. The programming error does change, but the window maintains a constant length of 160 mm centered at 0.
  - As the power level increases the programming error increases at 25 mm and 5 mm air gaps. The trend does not hold at air gaps larger than 25 mm.

Future testing is needed to more accurate determine where the power level transition lies. This information is useful to optimize programming environments. If this is not understood, it could be possible to unintentionally modify a programming environment for poor performance.

- The system performs significantly different at the 0 position as the air gap increases.
  - A “dead spot” appears at the 0 offset distance when the air gap is equal to or greater than 25 mm (this is true for all power levels). The “dead spot” does not appear at the 5 mm air gap.

One of the main differences is that the 5 mm air gap lies in the Reactive near field region and the remaining tested air gaps lies in the Radiative near field region. The radiation pattern changes between the two types of regions, one resulting in full programming coverage and the other produces a “blind spot”.

A future are of resting would need to be conducted to defined boundary where the reactive and radiative is located. Using the current data, the optimal boundary lies between 5mm and 49 mm.



**Figure 99: The four RF regions**

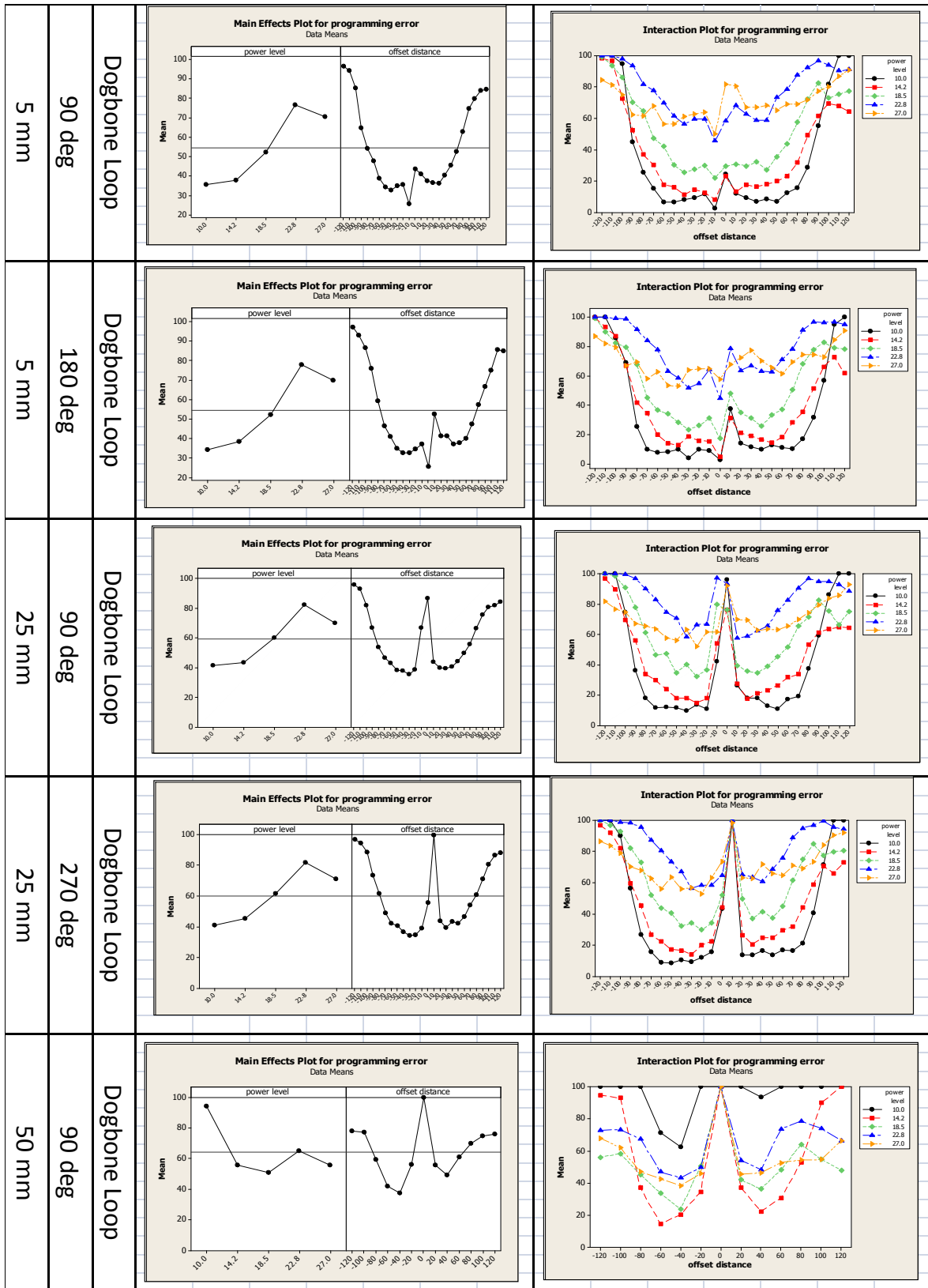
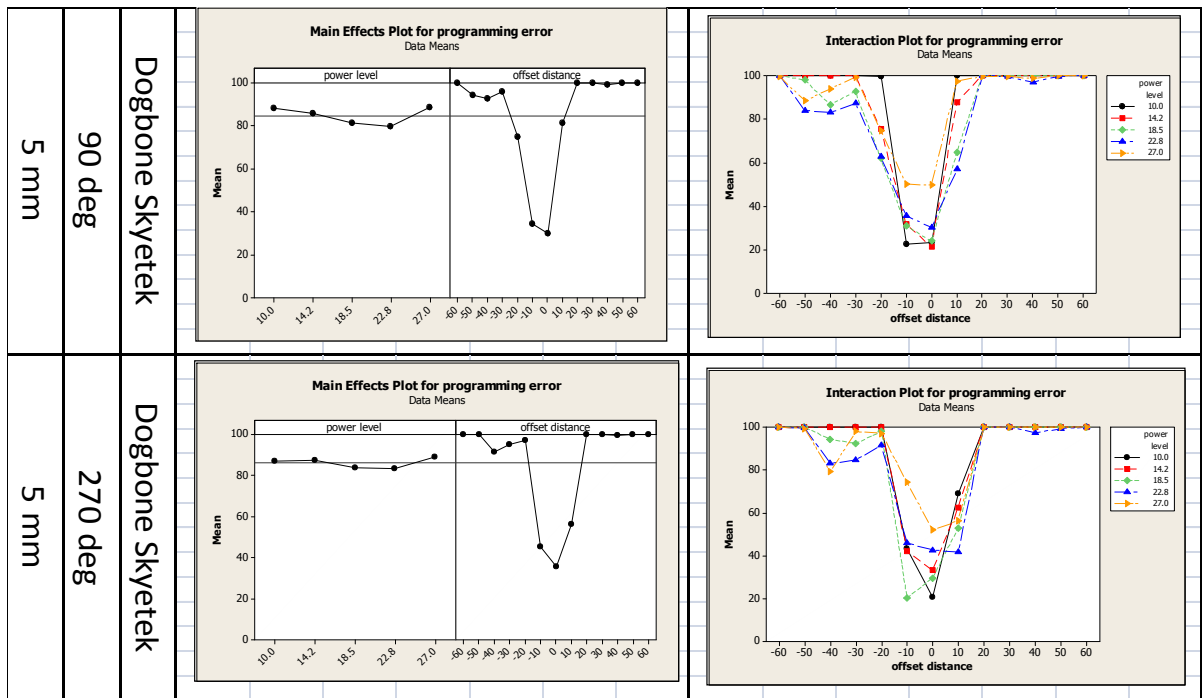


Figure 100: Static offset Dogbone Loop programming environments

## Dogbone – Skyetek Environment Inferences

- The programming window with 50% to 20% programming occurs between -10 mm to 10 mm. A total length of 20mm centered on 0.
- The programming error decreases as the tag approach 0. Or the programming error increases as the tag moves from 0.
- Both optimal programming angles perform similar. No significant difference.
- The *power level* programming factor does not affect programming error.
- The Offset distance programming factor does have a significant effect on programming error.
- The system performs significantly different at the 0 position as the air gap increases.
- Additional air gaps were not tested due to the high programming error and limited programming window.



**Figure 101: Static Offset Dogbone Skyetek**

## Dogbone – Meander Environment Inferences

- The programming window was skewed in the positive direction for all Dogbone – Meander programming environments.
- The air gap significantly affected the length of the programming window.
  - The optimal programming window occurred at the 25 mm air gap. It had a programming error of 40% to 10 occurred between -20 mm to 60 mm. A total length of 80mm centered on 20 mm.
- Both optimal programming angles perform similar. No significant difference.
- At the 25 mm and 50 mm air gaps the programming error was reduced with higher power levels.

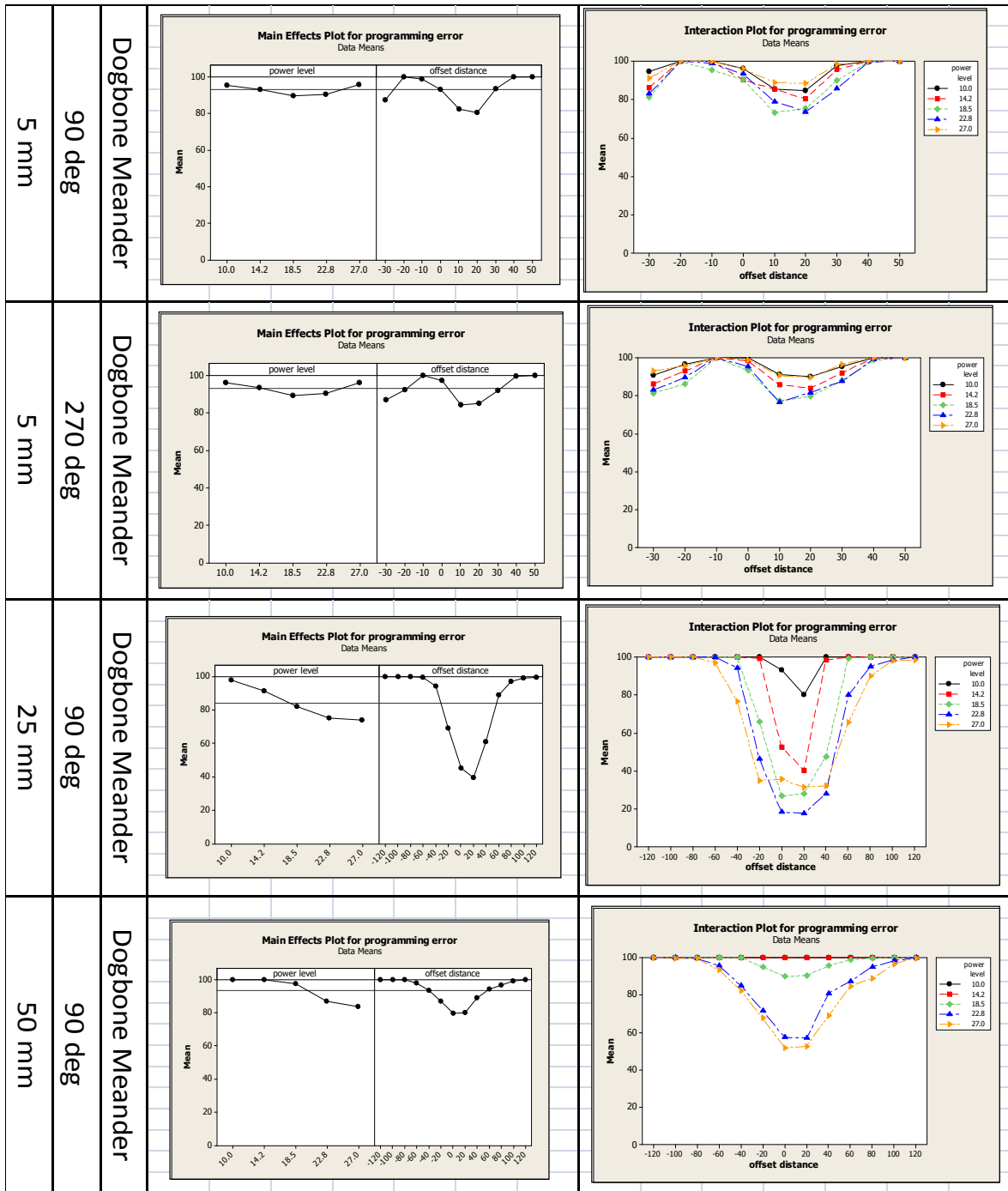


Figure 102: Static Offset Dogbone Meander

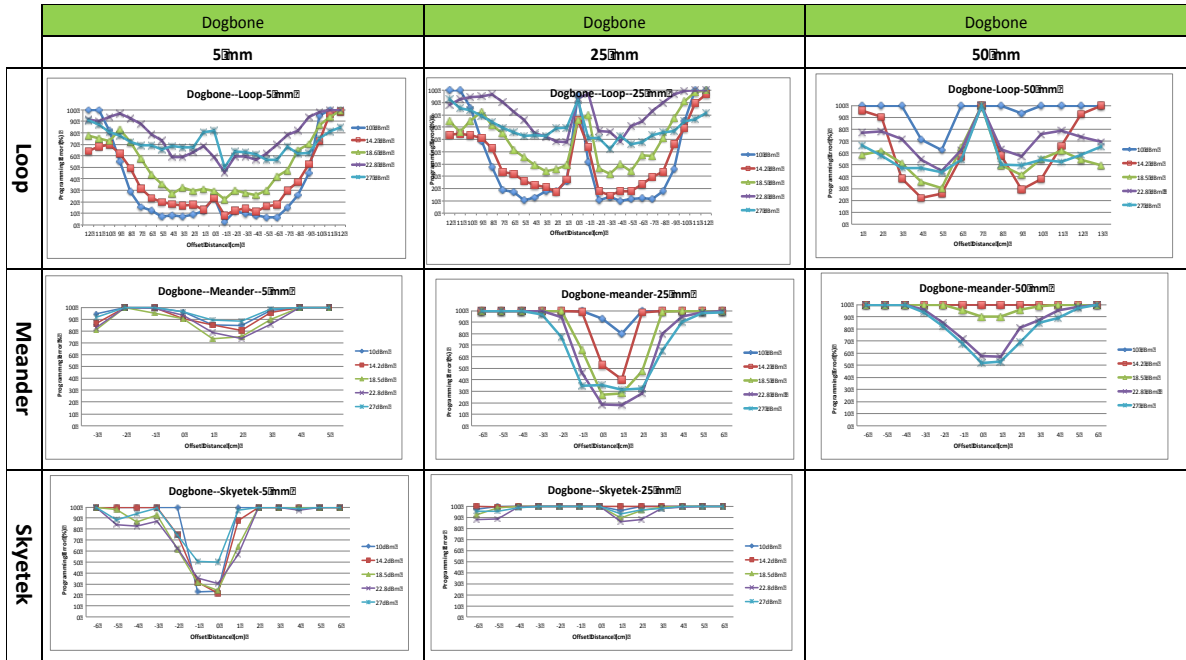
Summary of all Programming Environments

- The optimal programming environment is Dogbone – Loop – 90 deg – 5 mm.
  - The Loop antenna had the largest programming window (8 times larger than the Skyetek and 4 times larger than the Meander)
  - The Loop had the lowest programming error.

**Table 32: Static Offset programming window summary**

	Programming Window		
	Length	Center Point	Lowest Programming Error
Loop	160 mm	0	< 10%
Skyetek	20 mm	0	20 %
Meander	80 mm	20 mm	20%

The table above is summary of the static offset programming window results at a high level.



**Figure 103: Static Offset Dogbone Summary**

Loop antenna “dead spot”

Recall from section 4.2.3.2, For relatively small antenna apertures the equation to define the transition boundary from the reactive to the radiative NF is:

$$r = 0.62 \sqrt{\left(\frac{D^3}{\lambda}\right)}$$

**Equation 54**

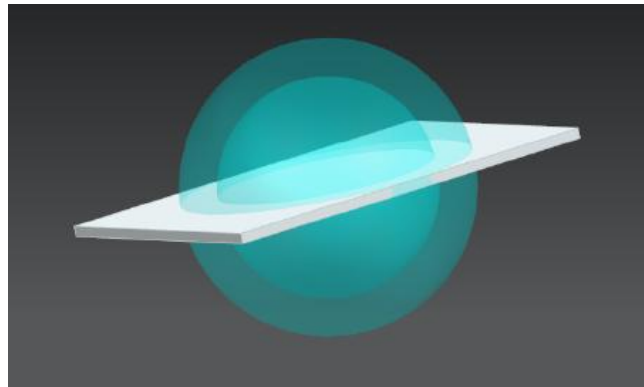
Where r is the transition boundary, D is the diameter of the antenna aperture loop (m), and λ is the wavelength (m). Using the following inputs provides a transitional boundary between the reactive and radiative fields at 16.3-16.4 mm: Loop antenna diameter (0.6096 m ≈ 2.4 in) and frequency 915 – 928 x 10<sup>6</sup> hertz UHF US). This means that a reactive near field sphere has a 16.3 mm radius that is created around the Loop antenna.

The radiative near field transition boundary is calculated using the same D and f, but with the following equation

$$r = 2 \left( \frac{D^2}{\lambda} \right)$$

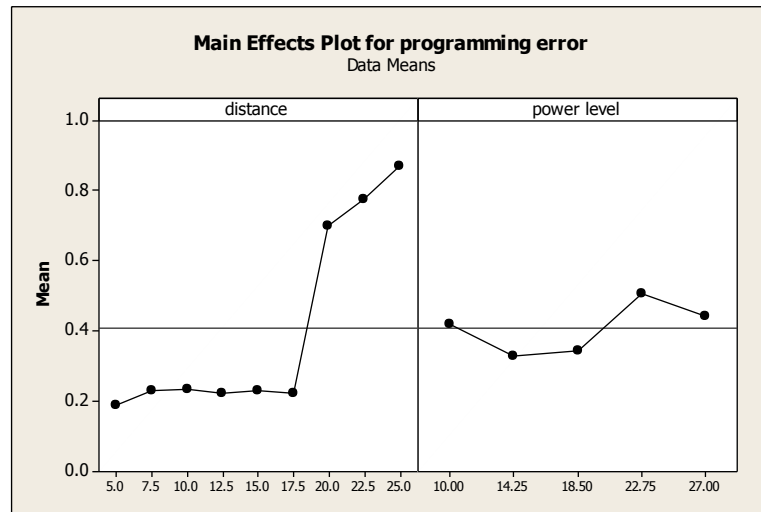
**Equation 55**

The transitional boundary from the radiative near field to the transition zone occurs between 22.67 – 23 mm. Figure 10 has each near field sphere centered about the loop antenna.



**Figure 104: Reactive sphere and radiative sphere centered about the Loop antenna**

Experimental data (Figure 11) indicates that the transition boundary occurs at 17 mm for the Dogbone tag oriented parallel to the antenna (i.e. 270°). This is true for all five power levels tested ranging from 10 dBm to 27 dBm).



**Figure 105: Transition boundary between the reactive and radiative near field regions**



There are two hypotheses for the discrepancy between the analytical and empirical. The first is that the Loop antenna shape represents an oval instead of a pure circle. This could have an impact on the equations used because they assume the shape is a pure circle. The second hypothesis is that the transitional boundary is tag type dependant. The tag infrastructure can change greatly from tag type to tag type. This includes the antenna design, IC type and IC substrate. Additional testing is required to determine if the transitional boundary is dependent upon tag type.

### 10.4.3 Static Offset Conclusion

The statistical results were not as clear as the static read and static write tests. The significant programming factor was not constant across all the Dogbone programming environments. The offset distance programming factor was not dominate in any of the programming environments. This was analyzed by comparing the last point where the programming error was not zero and the nominal position. Both optimal programming angles,  $90^\circ$  and  $270^\circ$ , produced the same statistical results.

The power level programming factor was significant in changing the programming error in all Dogbone Loop programming environments, but was not a significant programming factor for the two Skyetek programming environments. The power level programming fact was significant at the Meander - 50mm air gap. It was less significant to not significant at the lower air gaps.

Overall the optimal programming environment was the Dogbone tag, Loop antenna, 90 degree angle and 5 mm air gap programming environment. The Loop antenna had the largest programming window (8 times larger than the Skyetek and 4 times larger than the Meander). The Loop had the lowest programming error.

#### Summary: Dogbone – Loop Environment

- The programming window with 55% to 10% programming occurs between -80 mm to 80 mm. A total length of 160mm centered on 0.
- The programming error decreases as the tag approach 0. Or the programming error increases as the tag moves from 0.
- Both optimal programming angles perform similar. No significant difference.
- The length of the programming window is similar at the air gaps. The programming error does change, but the window maintains a constant length of 160 mm centered at 0.
  - As the power level increases the programming error increases at 25 mm and 5 mm air gaps. The trend does not hold at air gaps larger than 25 mm.

Future testing is needed to more accurate determine where the power level transition lies. This information is useful to optimize programming environments. If this is not understood, it could be possible to unintentionally modify a programming environment for poor performance.

- The system performs significantly different at the 0 position as the air gap increases.
  - A “dead spot” appears at the 0 offset distance when the air gap is equal to or greater than 25 mm (this is true for all power levels). The “dead spot” does not appear at the 5 mm air gap.

One of the main differences is that the 5 mm air gap lies in the Reactive near field region and the remaining tested air gaps lies in the Radiative near field region. The radiation pattern changes between the two types of regions, one resulting in full programming coverage and the other produces a “blind spot”.

A future are of resting would need to be conducted to defined boundary where the reactive and radiative is located. Using the current data, the optimal boundary lies between 5mm and 49 mm.

#### Summary: Dogbone – Skyetek Environment

- The programming window with 50% to 20% programming occurs between -10 mm to 10 mm. A total length of 20mm centered on 0.
- The programming error decreases as the tag approach 0. Or the programming error increases as the tag moves from 0.
- Both optimal programming angles perform similar. No significant difference.
- The *power level* programming factor does not affect programming error.
- The Offset distance programming factor does have a significant effect on programming error.
- The system performs significantly different at the 0 position as the air gap increases.
- Additional air gaps were not tested due to the high programming error and limited programming window.

#### Summary: Dogbone – Meander Environment

- The programming window was skewed in the positive direction for all Dogbone – Meander programming environments.
- The air gap significantly affected the length of the programming window.
  - The optimal programming window occurred at the 25 mm air gap. It had a programming error of 40% to 10 occurred between -20 mm to 60 mm. A total length of 80mm centered on 20 mm.
- Both optimal programming angles perform similar. No significant difference.
- At the 25 mm and 50 mm air gaps the programming error was reduced with higher power levels.

### 10.4.4 **Recommended Next Steps**

The recommended next steps are based upon the static offset results:

- Dogbone – Loop: A “blind spot” at the nominal location was observed at air gaps larger than 5 mm. The root cause of the “blind spot” needs to be investigated. Also, a more accurate location where the “blind spot” begins would help answer if it is dependent upon near field type (i.e. reactive or radiative).
- Dogbone – Loop: The trend where the programming error increases as the power level increases is broken at the 50 mm air gap. A more accurate location where this occurs would be useful with respect to designing an optimal programming environment.
- Dogbone – Meander: The optimal programming window occurred at the 25 mm air gap. The upper and lower boundaries for the optimal programming window need to be defined. The results would allow an air gap range in which to produce a optimal programming window.

## 10.5 Dynamic



**Figure 106 Test Suite - Dynamic**

The purpose of Dynamic testing is to investigate tag programming error while the tag is moving at linear velocities. Linear velocity is the only new variable added compared to the previous static testing. The dynamic tested had the least test parameters. The Skyetek antenna was removed from the testing because of its poor programming error performance and small programming window. Only the single optimal test parameter was chosen for the tag type, antenna programming angle, and reader power level.

There were 5 linear velocities parameters introduced to the test matrix (see “linear velocities” column in the chart below. How they were determined and calculated will be discussed below.

**Table 33: Dynamic Test Matrix (yellow)**

	tag Types	Antenna Types	antenna angles	air gaps	power levels	Linear Distances	linear Velocities	tag sample size	treatments	Total Tests	Manual Tests	Data points
Static Read	2	3	8	4	5	1	0	3	10	28800	5760	2880000
Static Write	3	3	8	1	5	1	0	3	10	10800	2160	1080000
Static Offset 1	3	3	1	2	5	24	0	3	10	64800	12960	6480000
Static Offset 2	1	3	1	3	5	24	0	3	10	32400	6480	3240000
Dynamic	1	2	1	3	1	n/a	5	3	10	900	900	90000
												13,770,000

### 10.5.1 Test Parameters

The dynamic testing had the least degrees of freedom with respect to test parameters. The test was narrowed down to where only the Dogbone tag type was used to perform all tests. Also, only the optimal power level was used for each programming environment. One degree of freedom was removed from the air gap and antenna types due to high programming error. A total of 900,000 data points were collected for this set of data (1 tag type x 3 tag samples x 10 replicates x 2 antenna types x 1 angle x 2 air gap x 1 power levels x 5 linear velocities x 100 loops = 900,000 data points).

**Table 34: Dynamic Test Parameters**

Tag Types	Dogbone				
Tag Samples (treatments)	3				
Blocks	10				

Antenna Types	Meander	Loop			
Antenna Angles	Optimal angel for each tag type				
Air Gaps	5	25	50		
Power levels	Optimal power level for each tag type				
Linear Velocity	9 cms (20 ppm)	18 cms (40 ppm)	22 cms (50 ppm)	27 cms (60 ppm)	31 cms (70 ppm)

The table below lists the power levels used for each antenna type and air gap. They were determined from the static write tests results.

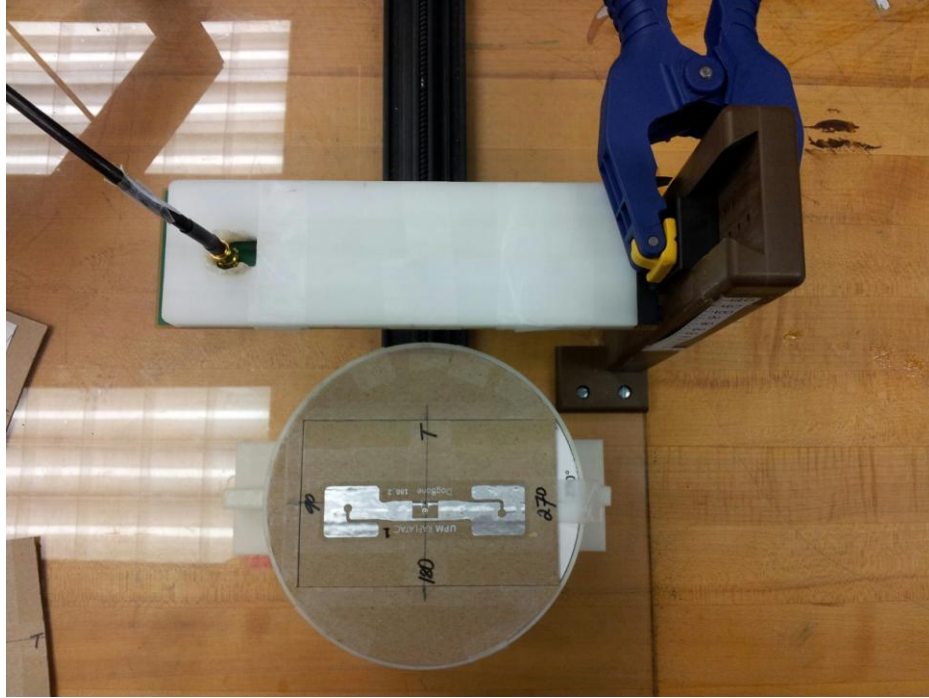
Air gap	Power Level (dBm)	
	Loop	Meander
5	27	18.5
25	27	22.8
50	18.5	27

**Figure 107: Power Level for each antenna type and air gap**

## 10.5.2 Test Setup

The home positions are the most positive location on the linear slide. The antenna always starts each dynamic test from this position (see the figure below). As the antenna moves from the negative to the positive direction the tag IC passes direction under the antenna. The tag IC is aligned with the center of the antenna.

A loop is one pass from the positive to the negative side of the linear slide. The return loop does not collect data and only the antenna returns to the “home” position.



**Figure 108: Dynamic testing linear slide home position**

### 10.5.3 Data Collection and Linear Velocities

The dynamic test data collection is different than the static tests. This difference is due to the linear velocity, as the linear velocity increases the amount of data points during the test decreases. Recall, the static tests collected 100 data points per test. The dynamic tests data points are greatly reduced, by a magnitude of 5 or greater, and the linear offset distance varies from test to test.

The test conducted at the slowest linear speed collected around 18-20 data points during one loop.

### 10.5.4 Statistical Analysis

There were three types of analysis performed for the dynamic testing. The three tests are listed below:

- Type I – Each individual air gap per antenna type was analyzed individually. A total of six analysis were performed, 3 for the Loop antenna and 3 for the Meander antenna. The programming error was the response variable.
- Type II – All three air gaps were analyzed together per each antenna type. A total of two analysis were performed, 1 for the Loop antenna and 3 for the Meander antenna. The programming error was the response variable.
- Type III – All three air gaps were analyzed together per each antenna type. A total of two analysis were performed, 1 for the Loop antenna and 3 for the Meander antenna. The percent of un-programmed tags was the response variable.
- Type IV - Each individual linear speed per air gap per antenna type was analyzed. A total of 30 analysis were performed, 5 per air gap and antenna type. The linear position was the response variable.

Each of the three analysis types are discussed in the follow three sections.

### 10.5.4.1 Dynamic Type I analysis

The Type I analysis consisted of six analysis where 3 test were performed for the Loop antenna and 3 tests were performed for the Meander antenna. Each individual air gap per antenna type was analyzed individually. The programming error was the response variable.

The DOE 2<sup>2</sup> factorial results are listed below. The tables are the p-values and F statistic from the null hypothesis analysis. The two main factors tested were linear velocity (V) and block (B). The interaction tested was between linear velocity and block (V\*B). The green cells indicated that the programming factor or interaction has a significant effect on the programming error. The red cells indicated that the programming factor or interaction that did not have a significant effect on the programming error.

Note that the interaction between the linear velocity and bock (P\*D) should be considered along the individual main effects results. This is because one of the main effect values could be large and the other small, which could results in the interaction being significant.

The expectations were that significant variation existed between the linear velocities and no variation exists between the blocks.

A few inferences can be made based upon the tables:

- The linear velocity programming factor was significant in changing the programming error in all Dogbone Loop and Meander programming environments.
- The linear velocity was most significant at the 25 mm air gap for the Loop antenna and most significant at the 5 mm air gap for the Meander antenna.
- There was no significant variation between blocks in all Dogbone Loop and Meander programming environments.
- The interaction between the linear velocity and blocks was only significant in the Loop 50 mm air gap programming environment. This is due to the blocks F statistic value is the highest compared to the other F-statistic values, which is close to the cut-off value.
- The statistical analyses match the expected results.

	Loop					
	p-value			F-Statistic		
	V	B	V*B	V	B	V*B
5 mm	0.024	0.263	0.763	5.23	1.26	0.09
25 mm	0.000	0.878	0.309	29.54	0.02	1.04
50 mm	0.000	0.198	0.032	14.080	1.67	4.66
				1.976	cut-off value	

**Figure 109: Dynamic Loop statistical analysis with all three air gaps individually**

	Meander					
	p-value			F-Statistic		
	V	B	V*B	V	B	V*B
5 mm	0.000	0.375	0.433	16.19	0.79	0.62
25 mm	0.009	0.753	0.735	7.1	0.1	0.12
50 mm	0.028	0.314	0.546	4.950	1.02	0.37
				1.976	cut-off value	

**Figure 110: Dynamic Meander statistical analysis with all three air gaps individually**

The statistical analysis was performed in Minitab. Below is an example data set produced from the Minitab analysis. The p-values and F-statistic are highlighted for each of the main effects, power level and angel, and the interaction between the main effects.

### Factorial Fit: programming error versus speed, block

Estimated Effects and Coefficients for programming error (coded units)

Term	Effect	Coef	SE Coef	T	P
Constant		0.748863	0.01168	64.10	0.000
speed	0.076023	0.038011	0.01662	2.29	0.024
block	0.041095	0.020548	0.01830	1.12	0.263
speed*block	-0.015714	-0.007857	0.02603	-0.30	0.763
S = 0.140711 PRESS = 3.05141					
R-Sq = 4.26% R-Sq(pred) = 0.00% R-Sq(adj) = 2.30%					

Analysis of Variance for programming error (coded units)

Source	DF	Seq SS	Adj SS	Adj MS	F	P
Main Effects	2	0.12695	0.12856	0.064278	3.25	0.042
speed	1	0.10360	0.10360	0.103600	5.23	0.024
block	1	0.02335	0.02496	0.024956	1.26	0.263
2-Way Interactions	1	0.00180	0.00180	0.001803	0.09	0.763
speed*block	1	0.00180	0.00180	0.001803	0.09	0.763
Residual Error	146	2.89074	2.89074	0.019800		
Lack of Fit	46	0.72194	0.72194	0.015694	0.72	0.889
Pure Error	100	2.16879	2.16879	0.021688		
Total	149	3.01949				

Unusual Observations for programming error

Obs	StdOrder	programming error	Fit	SE Fit	Residual	St Resid
1	1	0.52941	0.68245	0.04084	-0.15303	-1.14 X
2	2	0.58824	0.68245	0.04084	-0.09421	-0.70 X
3	3	0.70588	0.68245	0.04084	0.02344	0.17 X
28	28	0.87500	0.73926	0.04084	0.13574	1.01 X
29	29	0.72222	0.73926	0.04084	-0.01703	-0.13 X
30	30	0.64706	0.73926	0.04084	-0.09220	-0.68 X
91	91	0.40000	0.75750	0.02652	-0.35750	-2.59R
112	112	0.40000	0.78169	0.01892	-0.38169	-2.74R
127	127	0.16667	0.77982	0.02453	-0.61316	-4.43R

141            141            0.50000   0.79110   0.02087   -0.29110       -2.09R

R denotes an observation with a large standardized residual.  
X denotes an observation whose X value gives it large leverage.

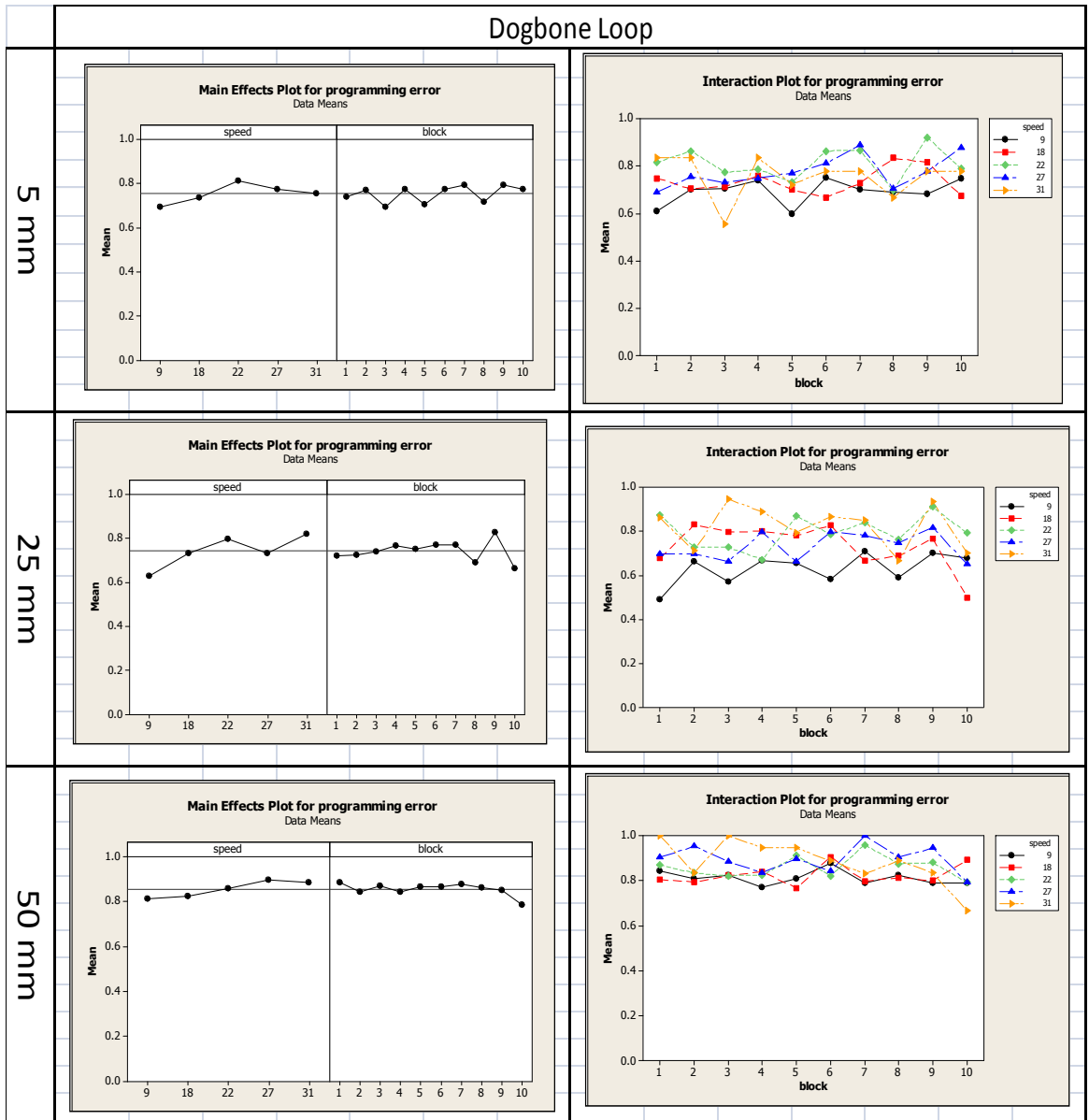
Estimated Coefficients for programming error using data in uncoded units

Term	Coef
Constant	0.637178
speed	0.00432856
block	0.0077406
speed*block	-1.58723E-04

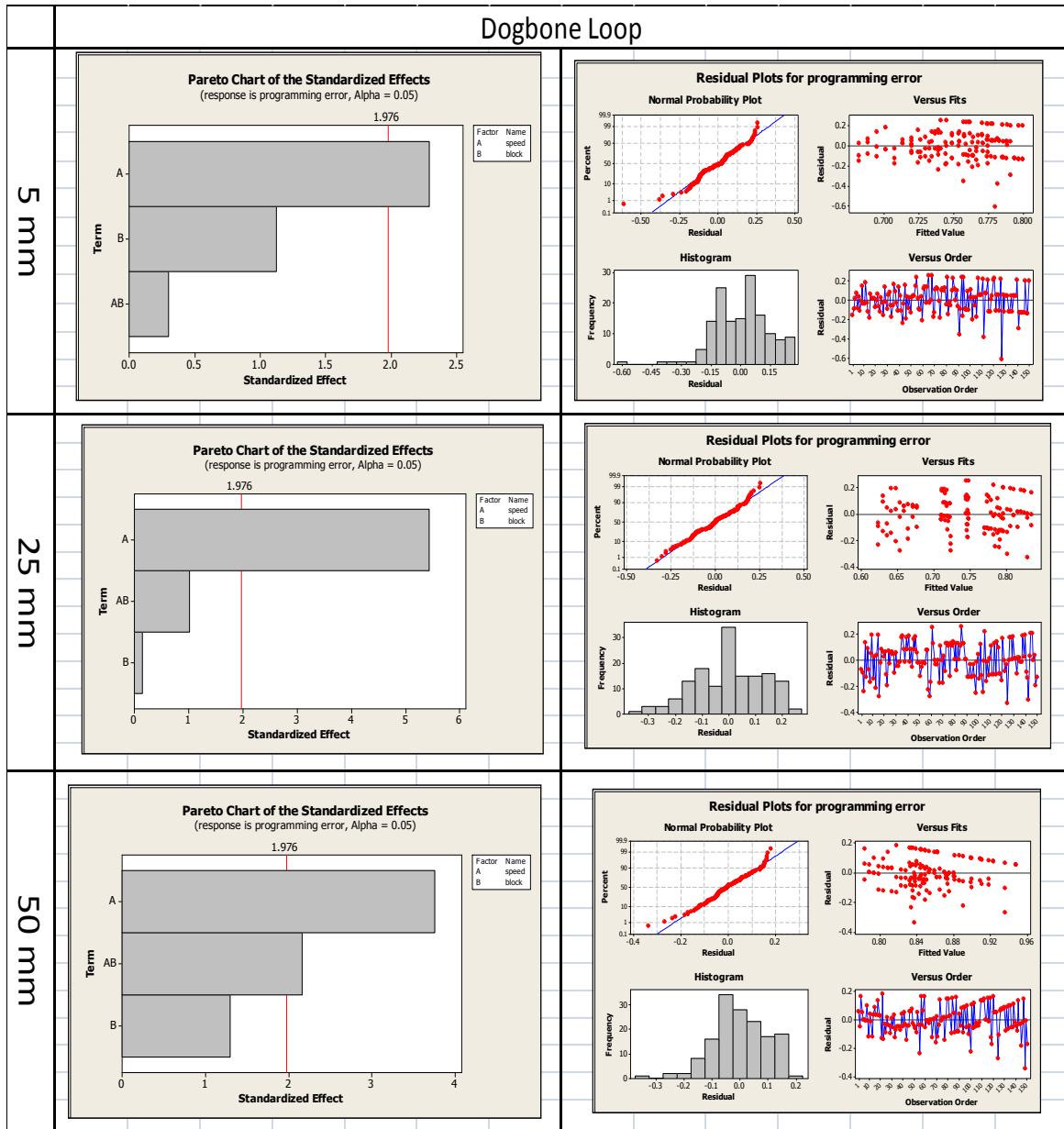
### Dogbone – Loop Environment Inferences

- At the 5 mm air gap, as the linear velocity increases the programming error increases from 9 cm/s to 22 cm/s. Then the programming error decreases from 22 cm/s to 27 cm/s.
- At the 25 mm air gap, as the linear velocity increases the programming error increases except at the 27 cm/s.
- At the 50 mm air gap, as the linear velocity increases the programming error increase.
- The block data indicates that outliers exist at one or two blocks during the testing. These outliers could be the root cause of the exception at the 25 mm air gap – 27 cm/s. The overall trend indicates that the programming error should increase. Repeating block 9 and 10 could possibly change the outcome.
- See figures 108 and 109 for supporting data results





**Figure 111: Dynamic Dogbone Loop main effects and interaction plots for 5, 25 and 50 mm air gaps**



**Figure 112: Dynamic Dogbone Loop Pareto residuals plots for 5, 25 and 50 mm air gaps**

Dogbone – Meander Environment Inferences

- At the 5 mm air gap, as the linear velocity increases the programming error increases except at the 22 cm/s.
- At the 25 mm air gap, as the linear velocity programming error is comparable at the 9, 22, and 27 cm/s linear velocities.
- At the 50 mm air gap, as the linear velocity increases the programming error increases except at the 22 cm/s.
- See Figures 10 and 11 for supporting data results

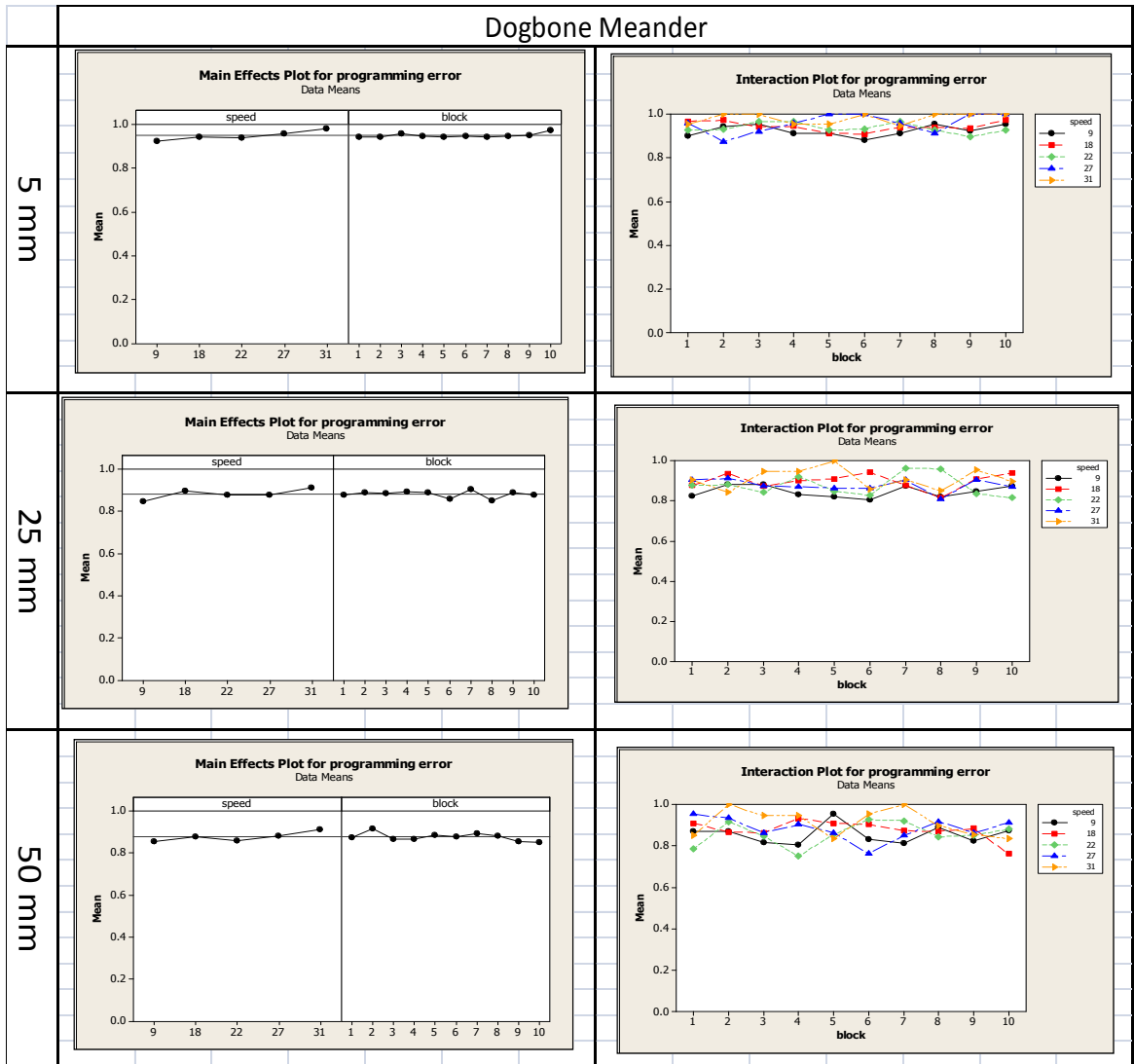


Figure 113: Dynamic Dogbone Meander main effects and interaction plots for 5, 25 and 50 mm air gaps

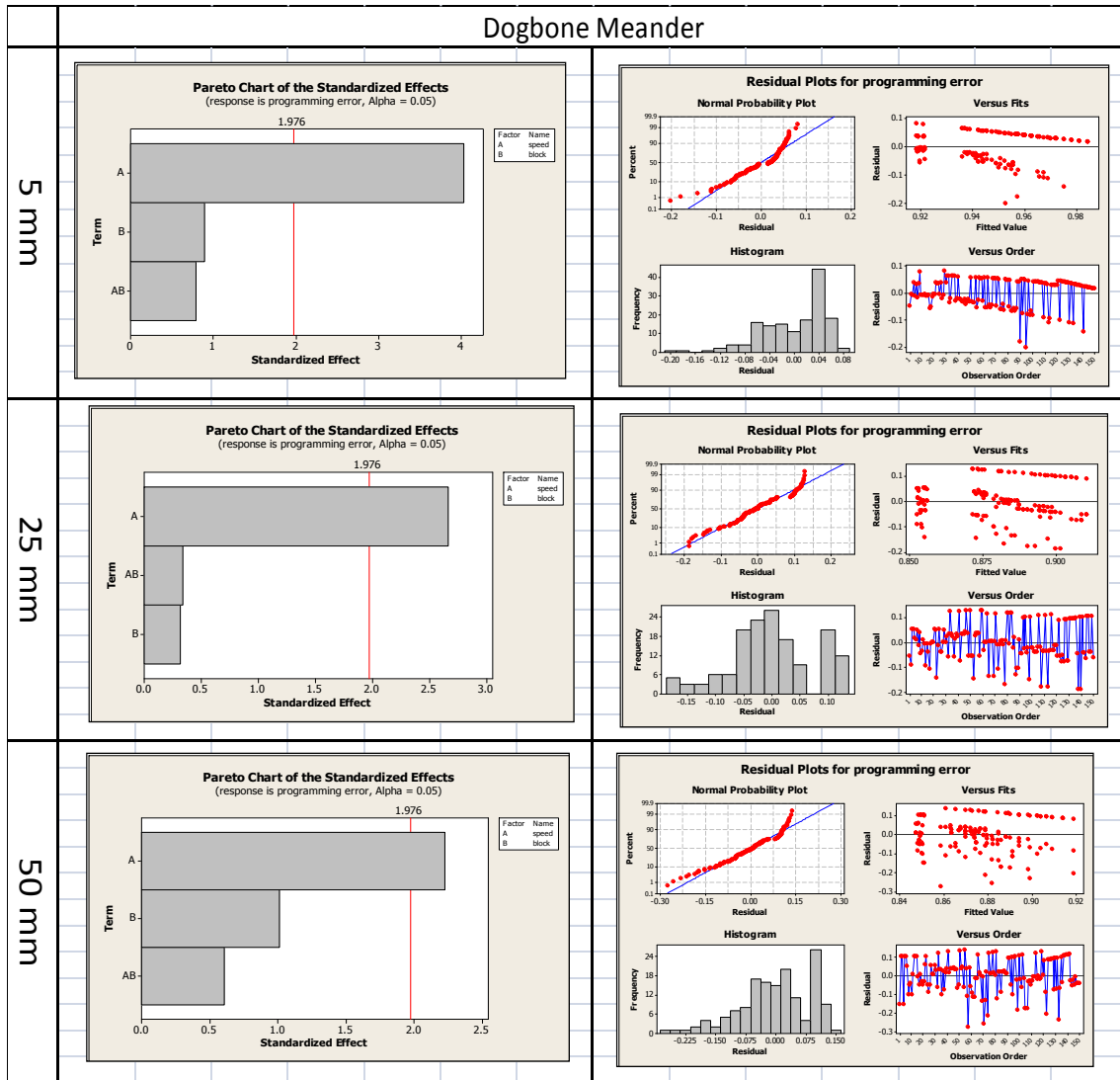


Figure 114: Dynamic Dogbone Meander Pareto residuals plots for 5, 25 and 50 mm air gaps

#### 10.5.4.2 Dynamic Type II analysis

The Type II analysis consisted of two analyses where 1 test was performed for the Loop antenna and 1 test was performed for the Meander antenna. Three air gaps were analyzed together per each antenna type. The programming error was the response variable.

The DOE 2<sup>2</sup> factorial results are listed below. The tables are the p-values and F statistic from the null hypothesis analysis. The two main factors tested were air gap (A) and linear velocity (V). The interaction tested was between linear velocity and block (A\*V). The green cells indicated that the programming factor or interaction has a significant effect on the programming error. The red cells indicated that the programming factor or interaction that did not have a significant effect on the programming error.

Note that the interaction between the linear velocity and bock (A\*V) should be considered along the individual main effects results. This is because one of the main effect values could be large and the other small, which could results in the interaction being significant.

The expectations were that significant variation existed within the air gaps and within the linear velocities. Also, it was expected that significant variation existed within the interaction between air gaps and linear velocities.

A few inferences can be made based upon the tables:

- The *linear velocity* programming factor was significant in changing the programming error in all Dogbone Loop and Meander programming environments.
- The linear velocity was most significant at the 25 mm air gap for the Loop antenna and most significant at the 5 mm air gap for the Meander antenna.
- There was no significant variation between *blocks* in all Dogbone Loop and Meander programming environments.
- The *interaction* between the linear velocity and blocks was only significant in the Loop 50 mm air gap programming environment. This is due to the blocks F statistic value is the highest compared to the other F-statistic values, which is close to the cut-off value.

		Loop					
		p-value			F-Statistic		
		A	V	A*V	A	V	A*V
Loop summary		0.000	0.000	0.921	49.85	39.51	0.01
					1.976 cut-off value		

**Figure 115: Dynamic Loop statistical analysis with all three air gaps combined**

		Meander					
		p-value			F-Statistic		
		A	V	A*V	A	V	A*V
Meander summary		0.000	0.000	0.902	60.26	21.81	0.02
					1.976 cut-off value		

**Figure 116: Dynamic Loop statistical analysis with all three air gaps combined**

Analysis 2 Dogbone – Loop Environment Inferences

- Programming error is similar at 5 mm and 25 mm air gaps and then increases at the 25 mm air gap.
- As the linear velocity increases the programming error increases from 9 cmfs to 22 cmfs. Then the programming error decreases from 22 cmfs to 27 cmfs.
- Air gap and linear velocity significantly change the programming error. The interaction between the air gap and linear velocity does not significantly change the programming error.
- See Figures 112 and 113 for supporting data results

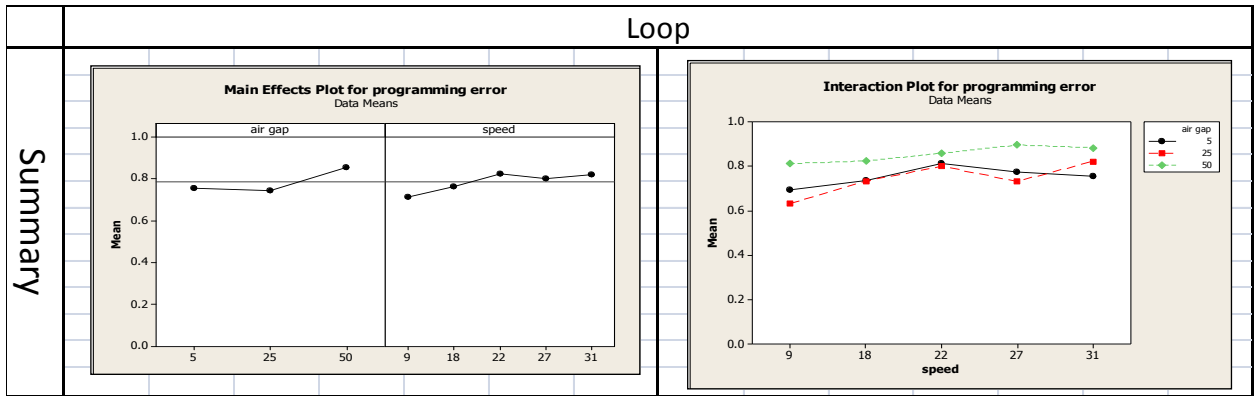


Figure 117: Dynamic Dogbone Meander main effects and interaction plots for 5, 25 and 50 mm air gaps Combined

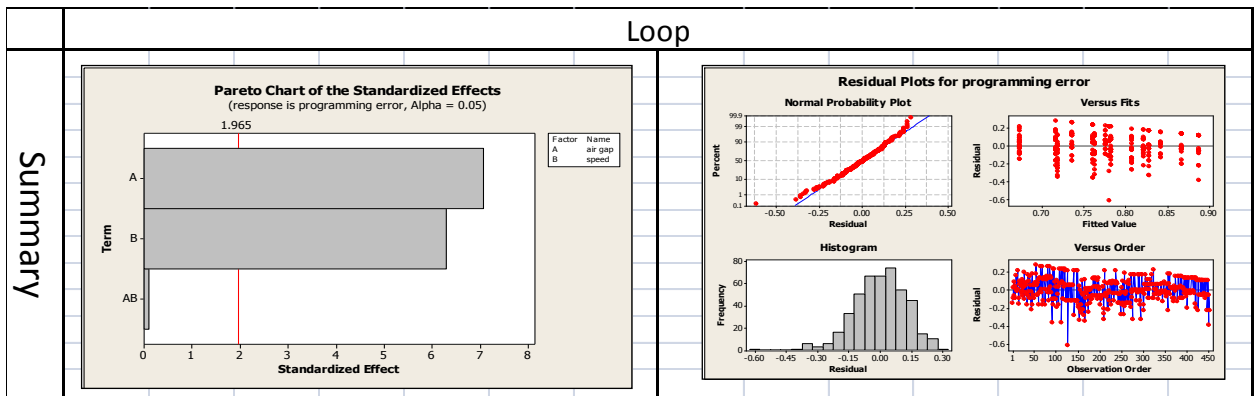


Figure 118: Dynamic Dogbone Meander Pareto Chart and Residual plots for 5, 25 and 50 mm air gaps Combined

Analysis 2 Dogbone – Meander Environment Inferences

- The programming error is highest at the 5 mm air gap.
- The linear velocity programming error is comparable at the 9, 22, and 27 cm/s linear velocities.
- Air gap and linear velocity significantly change the programming error. The interaction between the air gap and linear velocity does not significantly change the programming error.
- See Figures 114 and 115 for supporting data results

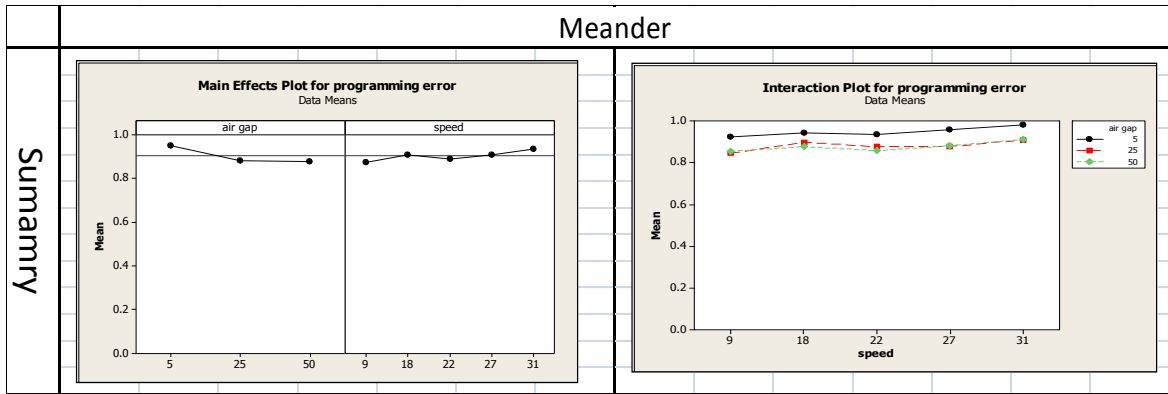


Figure 119: Dynamic Dogbone Meander main effects and interaction plots for 5, 25 and 50 mm air gaps Combined

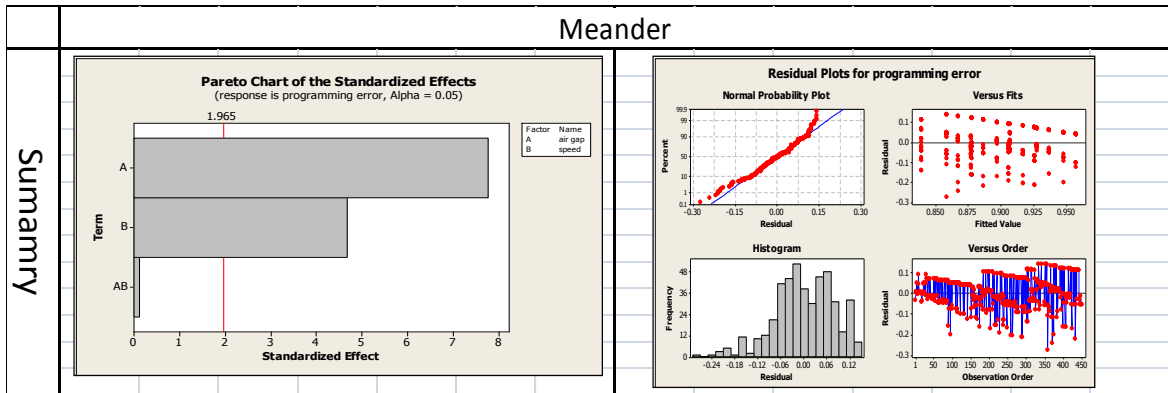


Figure 120: Dynamic Dogbone Meander Pareto Chart and Residual plots for 5, 25 and 50 mm air gaps Combined

### 10.5.4.3 Dynamic Type III analysis

The Type III analysis consisted of a total of two analyses where all three air gaps were analyzed together per each antenna type, 1 for the Loop antenna and 1 for the Meander antenna. The percent of un-programmed tags was the response variable.

The DOE 2<sup>2</sup> factorial results are listed below. The tables are the p-values and F statistic from the null hypothesis analysis. The two main factors tested were air gap (A) and linear velocity (V). The interaction tested was between linear velocity and block (V\*A). The green cells indicated that the programming factor or interaction has a significant effect on the programming error. The red cells indicated that the programming factor or interaction that did not have a significant effect on the programming error.

Note that the interaction between the linear velocity and bock (A\*V) should be considered along the individual main effects results. This is because one of the main effect values could be large and the other small, which could results in the interaction being significant.

The expectations were that significant variation existed within the air gaps and within the linear velocities. Also, it was expected that significant variation existed within the interaction between air gaps and linear velocities.

A few inferences can be made based upon the tables:

- The *linear velocity* programming factor was significant in changing the programming error in all Dogbone Loop and Meander programming environments.
- The *air gap* was significant only for the meander. This is due to the extremely poor performance at the 5 mm air gap.
- The *interaction* between the linear velocity and air gap was not significant for both the Loop and Meander programming environments.

	F-statistic			p-value		
	V	A	V*A	V	A	V*A
Loop	22.22	0.66	0.54	0.000	0.424	0.978
Meander	17.21	5.8	1.1	0.002	0.035	0.318
	2.056	cut-off value				

**Figure 121: Dynamic Type III analysis null hypotheses results**

The statistical analysis was performed in Minitab. Below is an example data set produced from the Minitab analysis. The p-values and F-statistic are highlighted for each of the main effects, power level and angel, and the interaction between the main effects.

Loop analysis

S = 0.165026      PRESS = 0.986277  
R-Sq = 46.86%      R-Sq(pred) = 25.98%      R-Sq(adj) = 40.73%

Analysis of Variance for un-programmed (coded units)

Source	DF	Seq SS	Adj SS	Adj MS	F	P
Main Effects	2	0.62435	0.621384	0.310692	11.41	0.000
Linear Speed	1	0.60598	0.605059	0.605059	22.22	0.000
air gap	1	0.01837	0.017992	0.017992	0.66	0.424
2-Way Interactions	1	0.00002	0.000021	0.000021	0.00	0.978
Linear Speed*air gap	1	0.00002	0.000021	0.000021	0.00	0.978
Residual Error	26	0.70808	0.708076	0.027234		
Lack of Fit	11	0.20141	0.201410	0.018310	0.54	0.845
Pure Error	15	0.50667	0.506667	0.033778		
Total	29	1.33244				

Meander Analysis

S = 0.154604      PRESS = 0.511878  
R-Sq = 70.04%      R-Sq(pred) = 41.67%      R-Sq(adj) = 61.86%

Analysis of Variance for un-programmed (coded units)

Source	DF	Seq SS	Adj SS	Adj MS	F	P
Main Effects	2	0.58837	0.54606	0.27303	11.42	0.002
Linear Speed	1	0.42166	0.41135	0.41135	17.21	0.002
air gap	1	0.16671	0.13858	0.13858	5.80	0.035
2-Way Interactions	1	0.02619	0.02619	0.02619	1.10	0.318



Linear Speed*air gap	1	0.02619	0.02619	0.02619	1.10	0.318
Residual Error	11	0.26293	0.26293	0.02390		
Total	14	0.87748				

The next two figures are the main effects for the Loop and Meander analysis. It is clear that linear velocity has a direct affect on the number of un-programmed tags that pass through the system. This is directly related to the reduced number of tag programming events as the linear velocity increases (See table 35 below).

Both analyses indicate that the optimal air gap occurs at the 25 mm air gap. The reason the 25 mm air is optimal is because of two factors: 1) length of programming window and 2) field strength. The 25 mm air gap has an improved length of programming window compared to the 5 mm air gap. Also, the 25 mm air gap has an improved field strength compared to the 50 mm air gap.

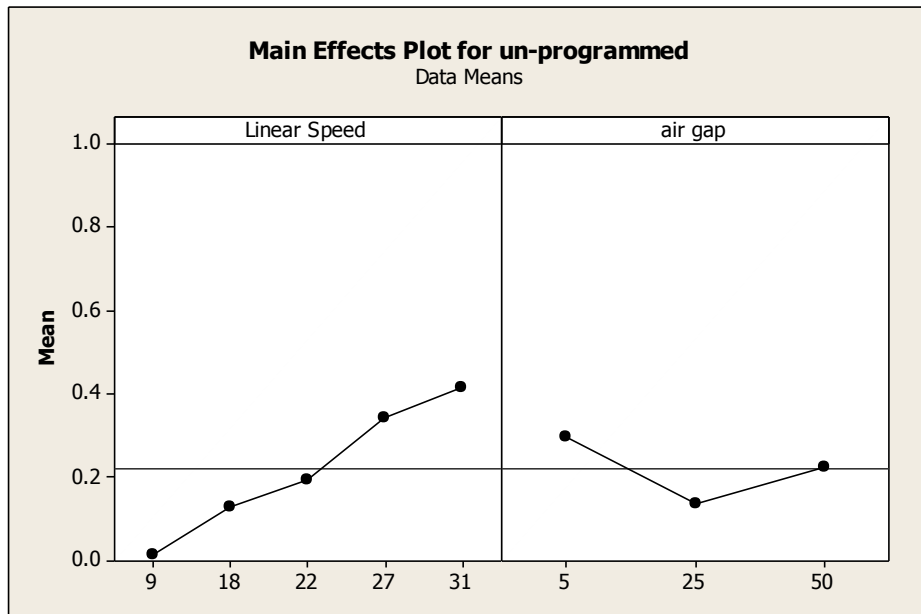
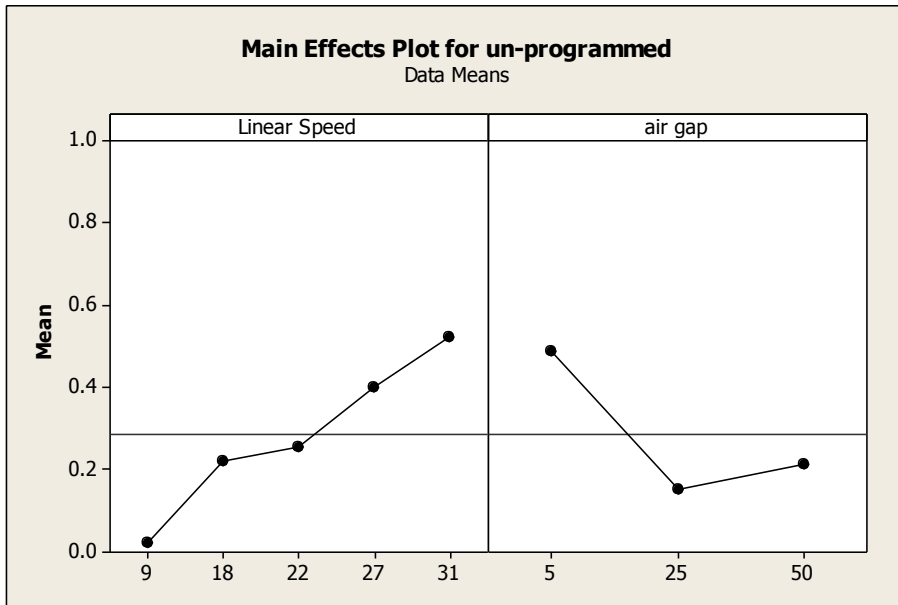


Figure 122: Dynamic type III analysis main effects – Loop antenna



**Figure 123: Dynamic type III analysis main effects – Meander antenna**

**Table 35: Dynamic Linear speed and number of total programming events**

Linear speed	Number of total programming events
9	19-23
18	9-12
22	7-9
27	6-8
31	5-7

The interaction plots for both antennas analysis continue to indicate that the 25 mm air gap the optimal air gap tested. What is interesting is that at the 25 mm air gap tags can move at higher linear velocities and have minimal negative impact when compared to both the 5 and 50 mm air gaps. The Meander has little to no negative impact between 18-31 cm/s.

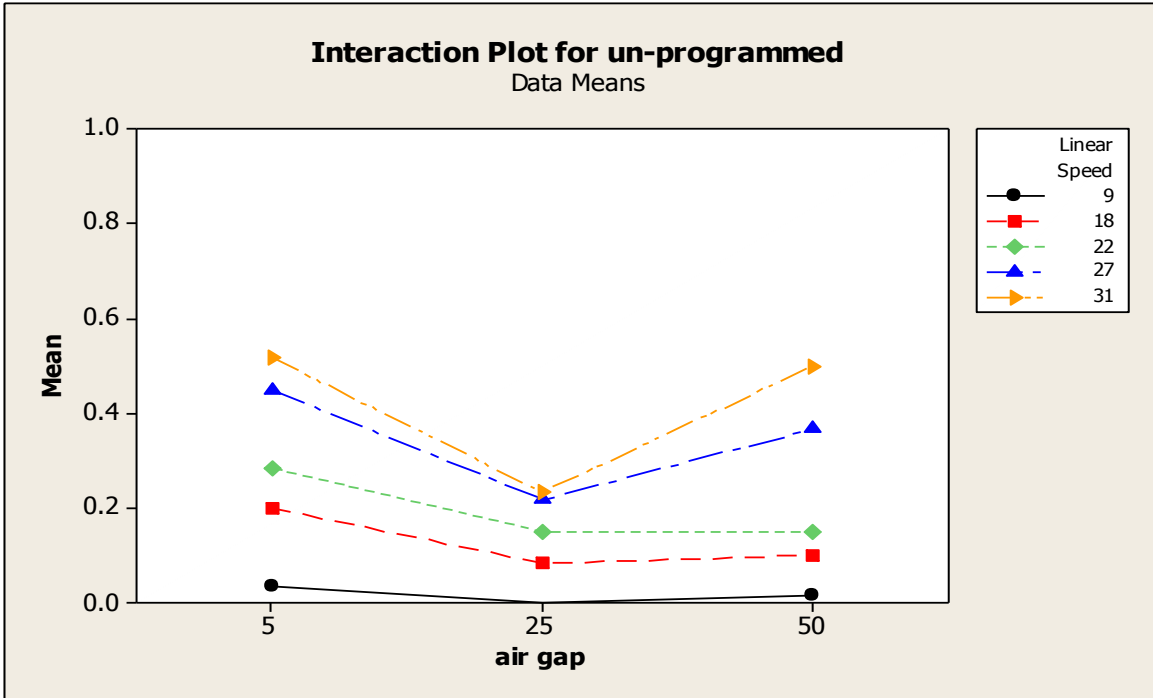


Figure 124: Dynamic type III analysis interaction plot - Loop antenna

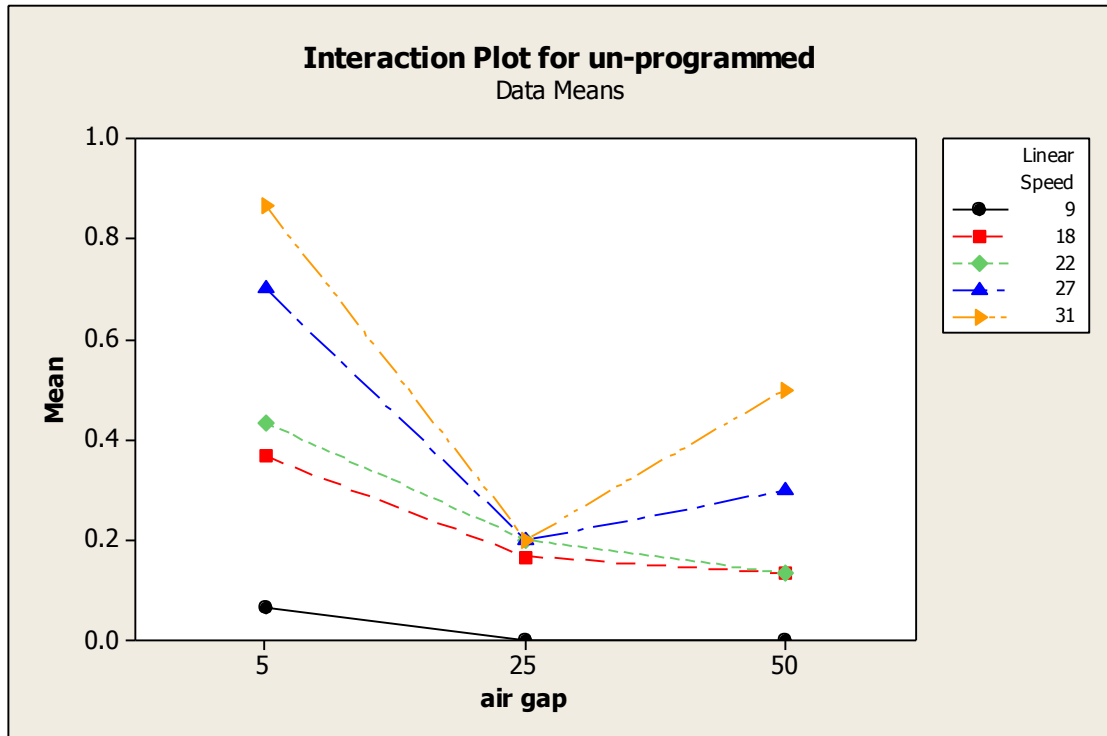


Figure 125: Dynamic type III analysis interaction plots - Meander antenna

The Pareto charts indicate that the angle significantly changes the number of un-programmed tags for both the Loop and Meander antenna types. These results align with the f-statistic and p-

values discussed on page 136. The air gap is only significant for the Meander antenna because of the wide range at the 5 mm air gap.

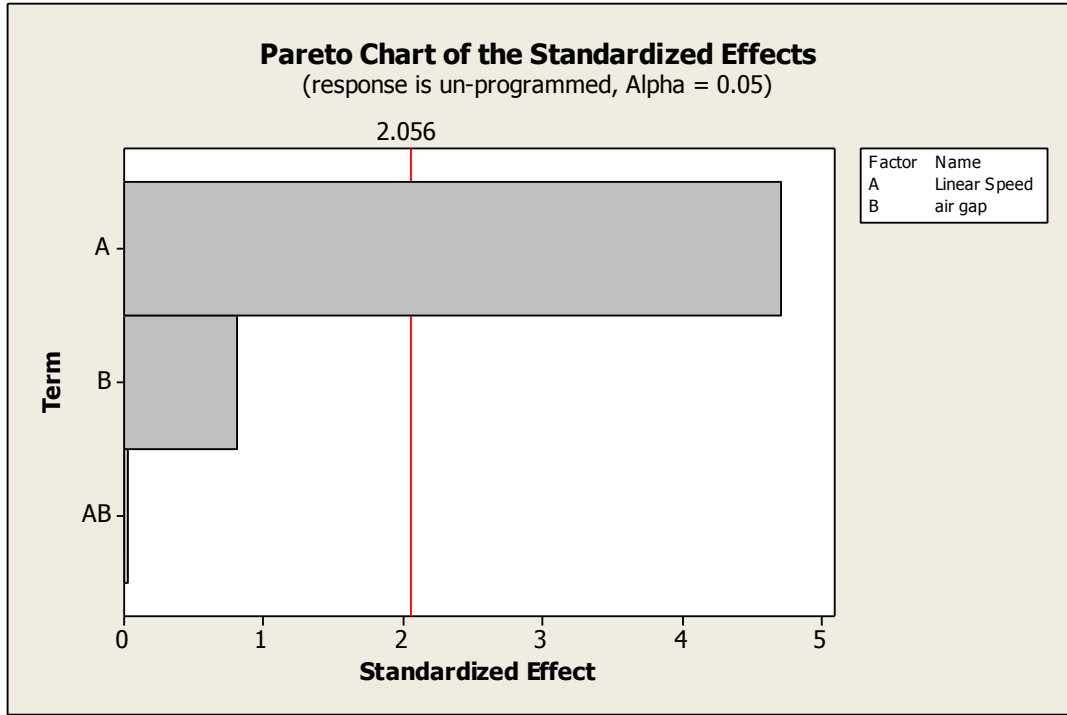


Figure 126: Dynamic Type III analysis - Loop Antenna

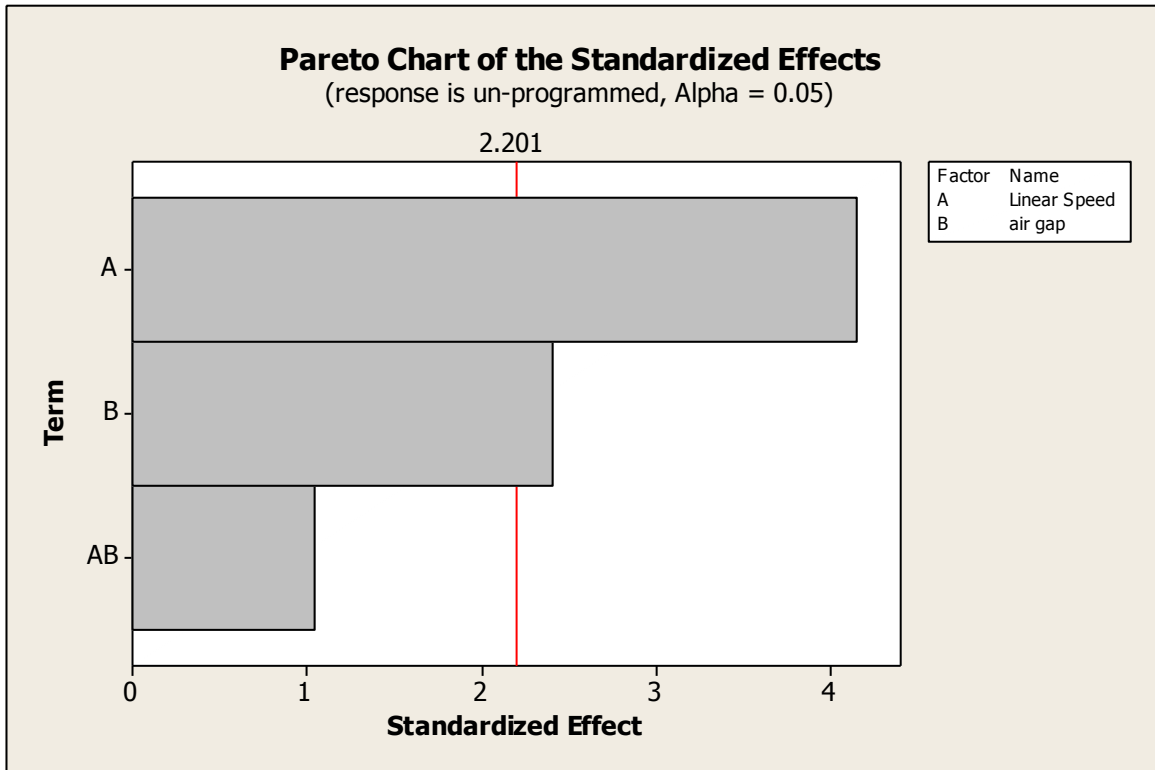


Figure 127: Dynamic type III analysis Pareto Chart - Meander antenna

The residual charts indicate the Loop antenna fits the linear model better than the Meander. This is due to the unstable programming environments at the 5 mm air gap. The histograms between each antenna type clearly show the difference.

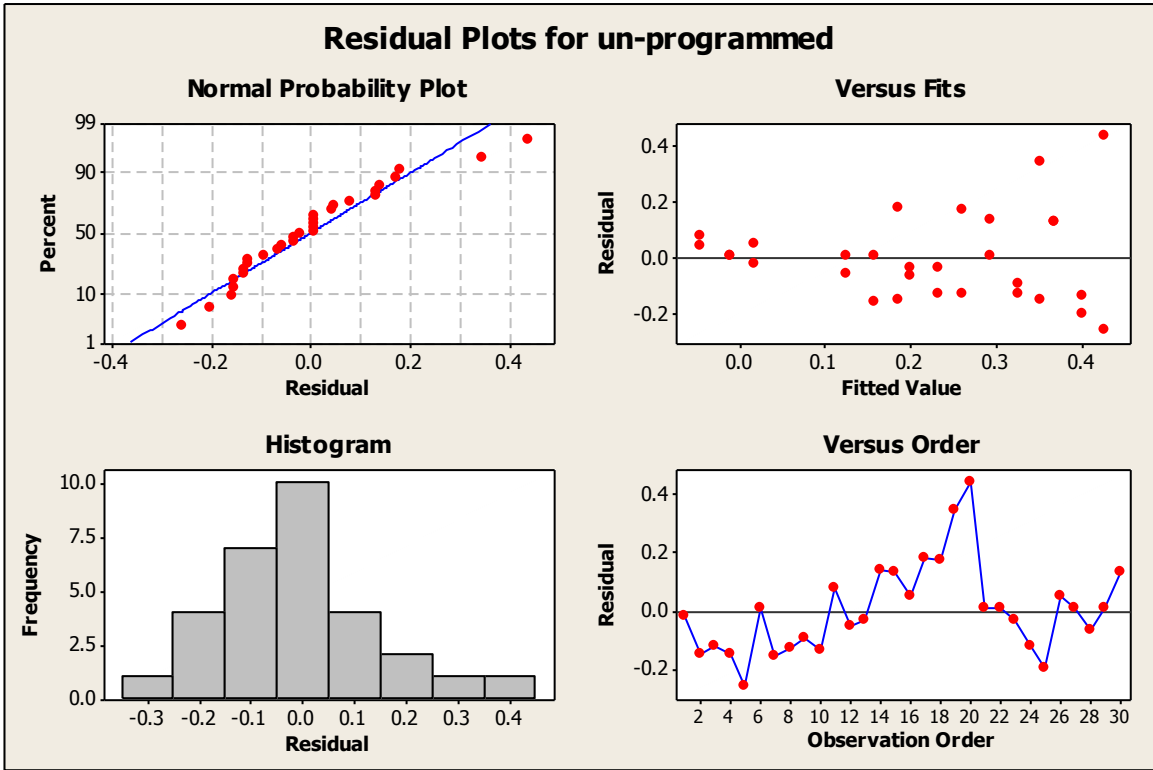
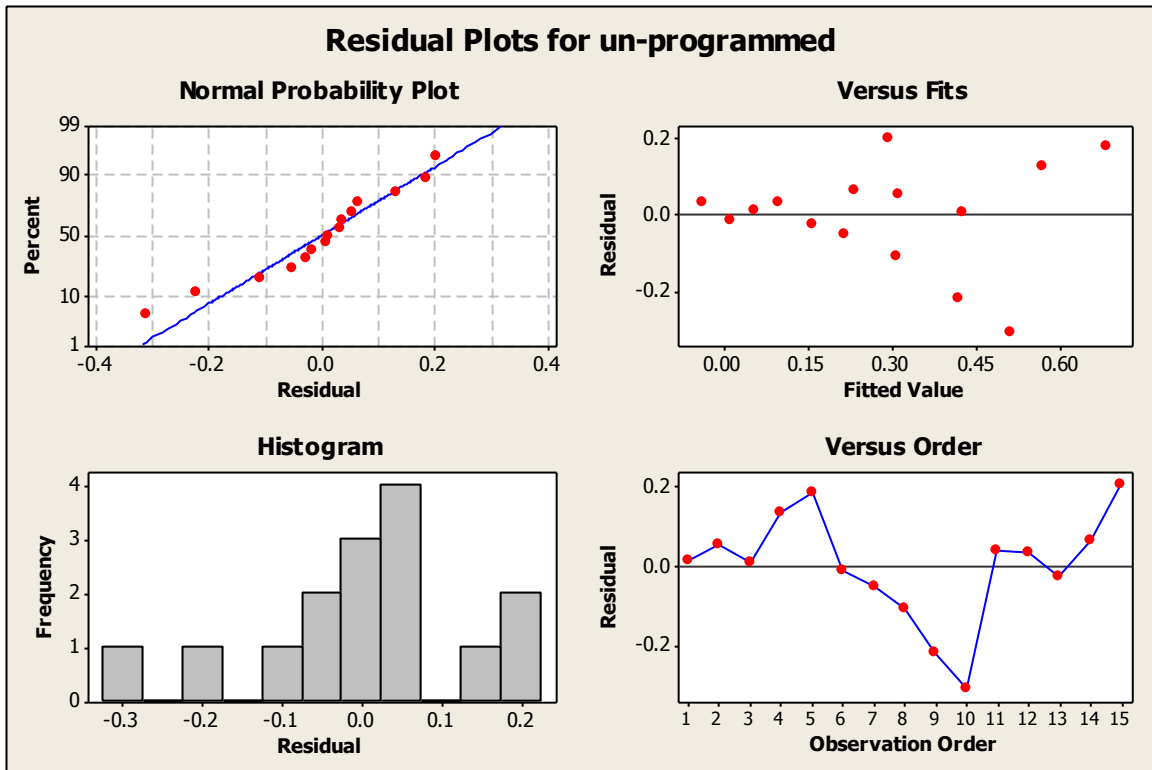


Figure 128: Dynamic type III analysis Residual plots - Loop antenna



**Figure 129: Dynamic type III analysis Residual Plots - Meander antenna**

#### 10.5.4.4 Dynamic Type IV analysis

The Type III analysis consisted of 30 analyses where 1 test was performed for each linear speed per air gap per antenna type. 5 tests per air gap and antenna type, where 15 were performed for the loop and 15 were performed for the meander. The response variable was the linear distance and number of un-programmed tags.

The purpose of the analysis was to determine the location where the successful write events occurred during the programming process. The linear distance is referenced from the center of the antenna location. The programming location is useful to know in relation to the antenna location because it indicates how much time is remaining after the successful write event.

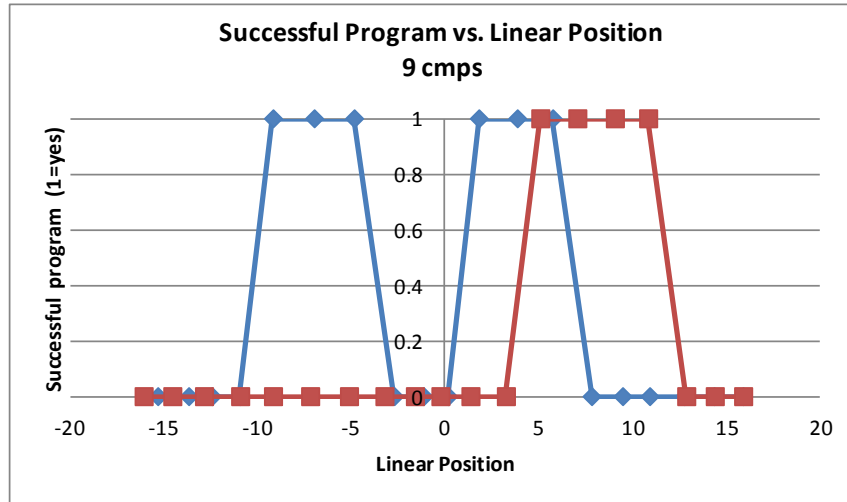
The extra time can be used to performed additional operations to the tag. Examples of addition operations are:

- Read and / or write to tags larger than 96 bit EPC memory,
- Access the extended memory,
- And password lock.

The programming location also indicates if the tags are successfully programmed at the beginning of the programming window or at the end. It desired that tag be programmed at the beginning of the programming window. This is important because if the tag is programmed early in the process the potential of an un-programmed tag passing through the system is reduced. This is because if the first attempts are unsuccessful then there is time for additional attempts. If the tags are not programmed until the end of the programming window then the potential of an un-

programmed tag passing through the system is increases. This is due to the fact there are few to zero attempts if the programming is unsuccessful.

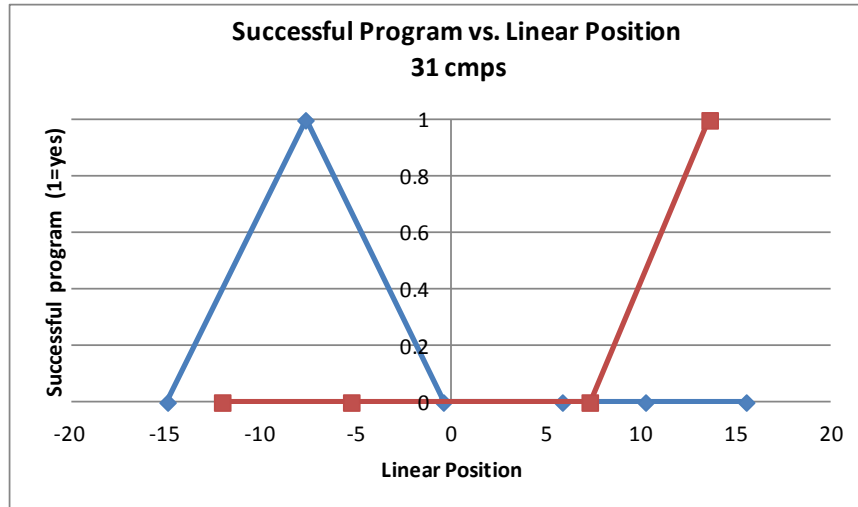
The figure below is from the Dogbone – Loop dynamic test at 9 cm/s. Two tests of the thirty are shown to represent the successful write events occurring before the antenna (blue) and one representing the successful events occurring after the antenna (right). 1 indicates a successful write and 0 indicates an unsuccessful write.



**Figure 130: Successful program vs. Linear Position (9cm/s)**

The figure below is from the Dogbone – Loop dynamic test at 31 cm/s. Two tests of the thirty are shown to represent the successful write events occurring before the antenna (blue) and one representing the successful events occurring after the antenna (right). 1 indicates a successful write and 0 indicates an unsuccessful write.

The red test had only one successful write event occurring at the last possible attempt. This is an issue because the tag was close to passing through the system un-programmed. Also, there is no time for additional operations to the tag.



**Figure 131: Successful program vs. Linear Position (31cmps)**

### 10.5.5 Dynamic Conclusion by analysis type

#### Analysis Type I

The Type I analysis consisted of six analysis where 3 test were performed for the Loop antenna and 3 tests were performed for the Meander antenna. Each individual air gap per antenna type was analyzed individually. The programming error was the response variable.

- The linear velocity programming factor was significant in changing the programming error in all Dogbone Loop and Meander programming environments.
- The linear velocity was most significant at the 25 mm air gap for the Loop antenna and most significant at the 5 mm air gap for the Meander antenna.
- There was no significant variation between blocks in all Dogbone Loop and Meander programming environments.
- The interaction between the linear velocity and blocks was only significant in the Loop 50 mm air gap programming environment. This is due to the blocks F statistic value is the highest compared to the other F-statistic values, which is close to the cut-off value.
- The statistical analyses match the expected results.

#### Dogbone – Loop Environment Inferences

- At the 5 mm air gap, as the linear velocity increases the programming error increases from 9 cmps to 22 cmps. Then the programming error decreases from 22 cmps to 27 cmps.
- At the 25 mm air gap, as the linear velocity increases the programming error increases except at the 27 cmps.
- At the 50 mm air gap, as the linear velocity increases the programming error increase.
- The block data indicates that outliers exist at one or two blocks during the testing. These outliers could be the root cause of the exception at the 25 mm air gap – 27 cmps. The overall trend indicates that the programming error should increase. Repeating block 9 and 10 could possibly change the outcome.



- See figures 108 and 109 for supporting data results

#### Dogbone – Loop Environment Inferences

- Programming error is similar at 5 mm and 25 mm air gaps and then increases at the 25 mm air gap.
- As the linear velocity increases the programming error increases from 9 cm/s to 22 cm/s. Then the programming error decreases from 22 cm/s to 27 cm/s.
- Air gap and linear velocity significantly change the programming error. The interaction between the air gap and linear velocity does not significantly change the programming error.
- See Figures 112 and 113 for supporting data results

#### Dogbone – Meander Environment Inferences

- The programming error is highest at the 5 mm air gap.
- The linear velocity programming error is comparable at the 9, 22, and 27 cm/s linear velocities.
- Air gap and linear velocity significantly change the programming error. The interaction between the air gap and linear velocity does not significantly change the programming error.
- See Figures 114 and 115 for supporting data results

#### *Analysis Type II*

The Type II analysis consisted of two analyses where 1 test was performed for the Loop antenna and 1 test was performed for the Meander antenna. Three air gaps were analyzed together per each antenna type. The programming error was the response variable

- The *linear velocity* programming factor was significant in changing the programming error in all Dogbone Loop and Meander programming environments.
- The linear velocity was most significant at the 25 mm air gap for the Loop antenna and most significant at the 5 mm air gap for the Meander antenna.
- There was no significant variation between *blocks* in all Dogbone Loop and Meander programming environments.
- The *interaction* between the linear velocity and blocks was only significant in the Loop 50 mm air gap programming environment. This is due to the blocks F statistic value is the highest compared to the other F-statistic values, which is close to the cut-off value.

#### Dogbone – Loop Environment Inferences

- Programming error is similar at 5 mm and 25 mm air gaps and then increases at the 25 mm air gap.
- As the linear velocity increases the programming error increases from 9 cm/s to 22 cm/s. Then the programming error decreases from 22 cm/s to 27 cm/s.
- Air gap and linear velocity significantly change the programming error. The interaction between the air gap and linear velocity does not significantly change the programming error.
- See Figures 112 and 113 for supporting data results

#### Dogbone – Meander Environment Inferences

- The programming error is highest at the 5 mm air gap.
- The linear velocity programming error is comparable at the 9, 22, and 27 cm/s linear velocities.
- Air gap and linear velocity significantly change the programming error. The interaction between the air gap and linear velocity does not significantly change the programming error.
- See Figures 114 and 115 for supporting data results

### **Analysis Type III**

The Type III analysis consisted of a total of two analyses where all three air gaps were analyzed together per each antenna type, 1 for the Loop antenna and 1 for the Meander antenna. The percent of un-programmed tags was the response variable.

- The *linear velocity* programming factor was significant in changing the programming error in all Dogbone Loop and Meander programming environments.
- The linear velocity was most significant at the 25 mm air gap for the Loop antenna and most significant at the 5 mm air gap for the Meander antenna.
- There was no significant variation between *blocks* in all Dogbone Loop and Meander programming environments.
- The *interaction* between the linear velocity and blocks was only significant in the Loop 50 mm air gap programming environment. This is due to the blocks F statistic value is the highest compared to the other F-statistic values, which is close to the cut-off value.

From the main effects plots (figure 117 and 118) it is clear that linear velocity has a direct effect on the number of un-programmed tags that pass through the system. This is directly related to the reduced number of tag programming events as the linear velocity increases (see table 35).

Both analyses indicate that the optimal air gap occurs at the 25 mm air gap. The reason the 25 mm air is optimal is because of two factors: 1) length of programming window and 2) field strength. The 25 mm air gap has an improved length of programming window compared to the 5 mm air gap. Also, the 25 mm air gap has an improved field strength compared to the 50 mm air gap.

The interaction plots (figure 119 and 120) for both antennas analysis continue to indicate that the 25 mm air gap the optimal air gap tested. What is interesting is that at the 25 mm air gap tags can move at higher linear velocities and have minimal negative impact when compared to both the 5 and 50 mm air gaps. The Meander has little to no negative impact between 18-31 cm/s.

### **Analysis Type IV**

The Type III analysis consisted of 30 analyses where 1 test was performed for each linear speed per air gap per antenna type. 5 tests per air gap and antenna type, where 15 were performed for the loop and 15 were performed for the meander. The response variable was the linear distance and number of un-programmed tags.

The programming location also indicates if the tags are successfully programmed at the beginning of the programming window or at the end. It desired that tag be programmed at the beginning of the programming window. This is important because if the tag is programmed early in the process the potential of an un-programmed tag passing through the system is reduced. This is because if the first attempts are unsuccessful then there is time for additional attempts. If the tags are not programmed until the end of the programming window then the potential of an un-

programmed tag passing through the system is increases. This is due to the fact there are few to zero attempts if the programming is unsuccessful.

### 10.5.6 Recommended next Steps

The recommended next steps are based upon the dynamic results:

- Optimal Air gap: Conduct additional tests on both sides of the 25 mm air gap to determine where the optimal air gap range is. The current results only say that 5 and 50 mm are not as good.
- Number Programming events: Additional testing should be tested with readers that have better performance specs, such as faster read and write times. The Thingmagic M5e (4x) and M6e (7.5x) both have faster performance specs than the Skyetek M9. Below are the tag singulation performance
  - Skyetek 50 tags per second
  - Thingmagic M5e 200 tags per second
  - Thingmagic M6e 750 tags per second

# 11 Conclusion

The overall test plan was designed to lay the foundation to understand the key factors that affect tag programming in the static environment. The first test was lengthy due to 960 degrees of freedom, but proved lay a solid foundation for the subsequent testing. Also, the test results helped eliminate many degrees of freedom and narrow the focus of the testing. The results indicated which programming environments were significant in changing the programming error. For example, the 100 mm air gap, Alien Squigg tag type and seven of eight angels were eliminated. This reduced the degrees of freedom of the air gaps from 4 to 3, the tag type from 3 to 2 and angles from 8 to 1.

With the reduced degrees of freedom and narrowed focus the static offset focused on the optimal tag programming angle for each tag type. Linear offset distance was introduced as a degree of freedom. The purpose of the testing was to define the length of the programming window independent of linear speed. This was important to understand when the tag entered and exited the RF programming field.

The static write results indicated that the Loop antenna type had the largest programming window at all three air gaps. The interested observations were that a programming “hole” appeared at 0 mm, directly under the antenna, at 25 and 50 mm air gaps. Further testing is required to determine where the boundary occurs. It is believed the root cause of the programming “hole” is due to the two different near field regions: reactive and radiative. The 5 mm air gap is believed to be in the reactive near field region where conductive coupling is used to program tags. The 25 mm air gap is believed to be in the radiative near field region where electromagnetic coupling is used to program tags.

Empirical testing is the best method to determine where the boundary exists between the 5 and 25 mm air gaps. Calculations predict that the boundary should occur between 15-20 mm.

The Meander had a 4 times smaller programming window when compared to the Loop antenna. The 5 mm air gap was nonexistent, the 25 mm air gap was the optimal air gap and the 50 mm was minimal.

The Skyetek was the worst performer at all air gaps. The only programming window occurred at the 5 mm air gap and was 2 cm long. Because of the poor performance, the Skyetek loop antenna was dropped from the testing.

With the length of the programming window defined independent of speed, dynamic testing was the next subsequent test. The dynamic testing was the last test in the test suite and was designed to confirm all testing up to that point. The previous testing confirmed the optimal tag type (Dogbone), programming angle (270 degrees), and power level (one per air gap).

The dynamic testing was analysis differently. 5 linear speeds were tested at three different air gaps and two antennas. The linear speed was significant at all three air gaps and both antennas. The variation between blocks was not significant. This was analyzed again since the dynamic data was collected differently. The data was repeatable and subsequent testing could be trusted.

Both air gap and linear velocity was significant for all air gaps together for both antennas. As the linear velocity increases the number of possible programming attempts decreases; therefore, this lead to lower programming performance for both antenna types. The air gap was less obvious.

Each antenna type has one air gap that the performance was lower. The Loop experienced the lowest performance at the 50 mm air gap and the Meander experienced the lowest performance at the 5 mm air gap.

The programming location also indicates if the tags are successfully programmed at the beginning of the programming window or at the end. It desired that tag be programmed at the beginning of the programming window. This is important because if the tag is programmed early in the process the potential of an un-programmed tag passing through the system is reduced. This is because if the first attempts are unsuccessful then there is time for additional attempts. If the tags are not programmed until the end of the programming window then the potential of an un-programmed tag passing through the system is increases. This is due to the fact there are few to zero attempts if the programming is unsuccessful.

Both antenna types performed their best at the 25 mm air gap. The most interesting finding was that as the linear velocity increased the negative impact became minimal. This indicates that the programming system efficiency could be increased by higher linear velocities with minimal negative impact on programming performance.

## 11.1 Recommended Programming Environment

The optimal programming environment out of 960 possible programming environments is the following:

- Tag Type Dogbone
- Programming angle 90° or 270°
- Air Gap 25 mm
- Power level 27 dBm
- Linear Speed 9 cm/s (0 un-programmed tags)  
31 cm/s (most efficient with minimal negative impact on programming performance)

## 11.2 Recommended Next Steps to expound upon this research data set

Below are the recommended next steps based upon the questions formed from the results.

The recommended next steps are based upon the static read and static write test results

- Conduct the rANOVA testing for the 25 and 50 mm air gaps (same as the 5 mm air gap). This will confirm that all possible programming environments are repeatable.

The recommended next steps are based upon the static offset results:

- Dogbone – Loop: A “blind spot” at the nominal location was observed at air gaps larger than 5 mm. The root cause of the “blind spot” needs to be investigated. Also, a more accurate location where the “blind spot” begins would help answer if it is dependent upon near field type (i.e. reactive or radiative).
- Dogbone – Loop: The trend where the programming error increases as the power level increases is broken at the 50 mm air gap. A more accurate location where this occurs would be useful with respect to designing an optimal programming environment.
- Dogbone – Meander: The optimal programming window occurred at the 25 mm air gap. The upper and lower boundaries for the optimal programming window need to be

defined. The results would allow an air gap range in which to produce a optimal programming window.

The recommended next steps are based upon the dynamic results:

- Optimal Air gap: Conduct additional tests on both sides of the 25 mm air gap to determine where the optimal air gap range is. The current results only say that 5 and 50 mm are not as good.
- Number Programming events: Additional testing should be tested with readers that have better performance specs, such as faster read and write times. The Thingmagic M5e (4x) and M6e (7.5x) both have faster performance specs than the Skyetek M9. Below are the tag singulation performance
  - Skyetek 50 tags per second
  - Thingmagic M5e 200 tags per second
  - Thingmagic M6e 750 tags per second

The recommended next steps are based upon improving the LexSlide1 test fixture:

- Improve antenna mount design to hold antenna constantly parallel to the tag. Current design had issues of maintaining parallelism with the tag.
- Add fine adjustment functionality to the air gap and tag programming angle. Current the air gap sensitivity is 5mm and the angle is 45 degrees. Increased sensitivity would allow further investigation for areas of interest.
- Build a second LexSlide test fixture that would include a longer linear slide track, higher tower and with Thingmagic readers. This would allow testing both sides of the programming window to define the end, faster speeds with faster readers, and higher air gaps with more powerful readers.

### **11.3 Recommended Next Steps for further testing**

These are the next set of tests based upon the results from this research:

- Repeat small subsets of the previous testing with ThingMagic readers.
- Multi up – programming multiple tags simultaneously with the same data.
- Multi up – programming multiple tags simultaneously with different data.

# Appendices

- A. The First RFID Passive System
- B. UHF RFID Applications Examples
- C. Companies that have implemented UHF RFID systems
- D. DOE 2<sup>3</sup> Factorial
- E. Static write Data
- F. Static Offset Data
- G. Glossary of Terms

## A. The First RFID Passive System

Radio frequency identification technology can be traced back to World War II and originates from radar. In 1935 a Scottish physicist Sir Robert Alexander Watson –Watt discovered radar, which the Germans, Japanese, Americans and British were all using. Radar was used to warn of approaching planes that were many miles away. The problem was there was no way to identify which planes belonged to the enemy and which were a country's own pilots returning from a mission.

The Germans discovered that if pilots would roll their planes as they approached base the radio signal reflected back would also change. This crude method was used by the Germans and it allowed the identification of which planes were friendly and which planes were foes. *This is, essentially, the first passive RFID system*

The British, under Watson-Watt, developed the first active identify friend or foe (IFF) system. A transmitter was placed in each British plane and it received signals from radar stations on the ground. The plane transmitter broadcasted a signal back that identified the aircraft as friendly. RFID works on this same basic concept. A signal is sent to the transponder, which wakes up and either reflects back a signal (passive system) or broadcasts a signal (active system). [17]



## B. UHF RFID Applications Examples

There are numerous UHF RFID applications ranging across many industries throughout the world. Below are a few examples from different industries to help provide solutions that are used today. It is worth noting that for each instance, different types and sizes of RFID tagged forms are being deployed.

- **Shipping & Tracking** – RFID technology has allowed products to be tracked from the manufacturer to the customer. When the finished or replacement goods are transferred from destination to destination, each product can be tracked immediately. This is completed by RFID tags embedded in the pallets and they are scanned when they leave and enter the trucks and warehouses. In a few seconds, each item's manufacturer, product and serial number are sent to the retailer's inventory system along with the item's location and time of delivery.
- **Manufacturing** – The automotive industry has used RFID technology to streamline their manufacturing process. They have successfully implemented the technology by embedding tags into parts and then scan the tag throughout the production line. This allows the manufacturer to identify the stage of the work in process (WIP) very quickly, report any problems, and tell if the process is on schedule. The part numbers are tracked to ensure "just-in-time" production efficiencies from the part vendors in the supply chain. The real-time information gives the parts supplier's information where their shipments can be modified to meet the automobile manufacturer's production goals.
- **Document Tracking** – Many different industries requires document tracking. Medical, legal and government are a few examples. Critical documents can be embedded with an RFID tag so the document can be tracked every time it is moved. RFID portals read the document as it passes through it and it will be prompted to check and verify if the person has the required credentials to move the document. If the building infrastructure is equipped with RFID portals the document can be tracked as it moves and the location and past movement can easily be checked. The embedded tag allows the complete history of all its users to be recalled along with specific dates and all the locations where the document has been.
- **Part Usage History** – The construction industry uses RFID tags to track their large parts. This is beneficial because maintenance and replacement of parts is critical for safety and cost. The tag that is located on the part can track the location and maintenance history. This information can be used to monitor the life cycle of the part, and can help determine when it should be replaced.
- **Hospital Patient Tracking** – When a patient is emitted to the hospital they will receive a medical wrist band with an embedded RFID tag. The RFID enabled wrist band can contain personal information, medical history and prescribed medication. This information can be used and updated real time as the patient is at the hospital. This type of tracking and monitoring can ensure that the patient is sent to the correct operation or recovery room, and that the appropriate medications and treatments are being administered. This type of system reduced the number of death and injuries due to mistaken IDs. Also, this results in fewer malpractice suits and lower costs for the hospital.

- **Product Recalls** – RFID technology provides both manufacturers and retailers with highly detailed product information. The product information can include specific manufacturing plant where a product was produced, the lot number, item number, color, flavor, size, model version and other types of similar information. When a product recall is announced, the RFID information can facilitate in the tracking and specific identification of the remaining products. This can prevent from pulling all the manufacturers' products off the shelf. RFID speeds up the process of removing the affected items from the distribution channel and allows retailers to safely continue selling non-recalled versions of the manufacturers' products that remain in their inventory.
  
- **Theft** – Theft is a drain on the retailer's bottom line. A common method of theft is when the consumer buys a product from a retailer at a discount and returns it to another retailer for a higher price. This can be a loss of millions of dollars for retailers. RFID can prevent this by tagging the items purchased. This allows the retailer to know if the item was purchased from them or at a different retailer.

## C. Companies that have implemented UHF RFID systems

There are numerous UHF RFID applications ranging across many industries throughout the world. Below are a few examples from different industries to help provide solutions that are used today.

- The Coca-Cola Company (retail): The Coca-Cola Company has set out to revolutionize their dispenser system by incorporating RFID technology into their machines. Their new Freestyle drink dispenser offers more than 100 drink options in a single machine. The machine utilizes RFID technology to identify 30 or more cartridges, determine the quality of flavoring inside each, and transmit data back to Coca-Cola indicating which drinks are being consumed, and when. [26]
- The Tavern Restaurant Group -The Pub (restaurants): The Pub has implemented RFID technology to control and manage the delivery of draft beer. Each glycol -cooled line is monitored by embedded RFID technology in the valve. The backroom server is accessible via the Internet. They can monitor every ounce of beer going to every tap in each restaurant 24/7 without being on site. [27]

The Pub also uses RFID embedded cards that they give to customers for use with self-serve beer taps. The customer scans the card before filling their glass. The card tracks the amount of beer consumed for payment and to ensure responsible consumption.

- Loves Travel Stops (retail): The company is testing a fuel management system that enables the drivers to fuel up more efficiently, while also ensuring against fuel fraud. Truck companies purchasing fuel at Love's Travel Stops have their trucks equipped with UHF RFID tags. This will allow the drivers to fuel up without scanning ID cards or entering data into a keypad. The advantage, for both drivers and their companies, is that this will not only speed up the fuelling process (by eliminating the need for ID cards), but also ensure against fuel fraud – a practice by which the fuel company drivers sells to another driver at the fueling station, at the firms expense. [28]
- Hanmi Pharmaceutical (pharmaceutical): The company adopted RFID to gain greater inventory visibility in pharmacies and to improve circulation throughout their supply chain. RFID has also improved health safety throughout South Korea by enabling efficient product recalls and counterfeit prevention. [29]
- Agricultural Bank of China (banking): The bank embeds tags into each money bag to minimize security risks and enhance reliability. RFID technology allows the money circulating through the banking system to be readily traced. The tag provides bag contents, status, location, and personnel who handled the bag. [30]

## D. DOE 2<sup>3</sup> factorial

A DOE was conducted with three programming factors: Power Level (A), air gap (B) and angle (C).

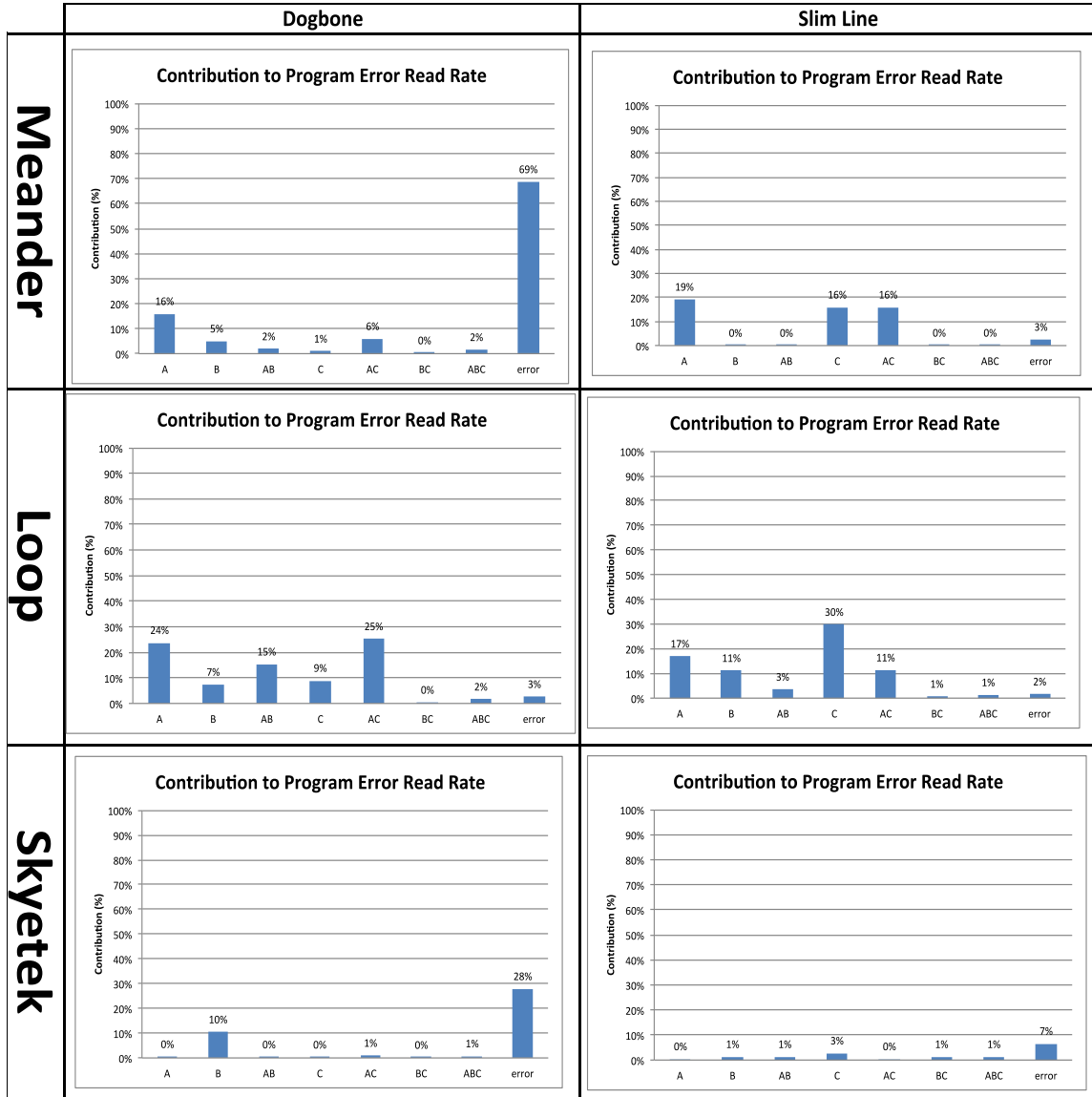


Figure D1: Static Read ANOVA for Dogbone and Slim Line

# E. Static Write Data

## Dogbone-Loop

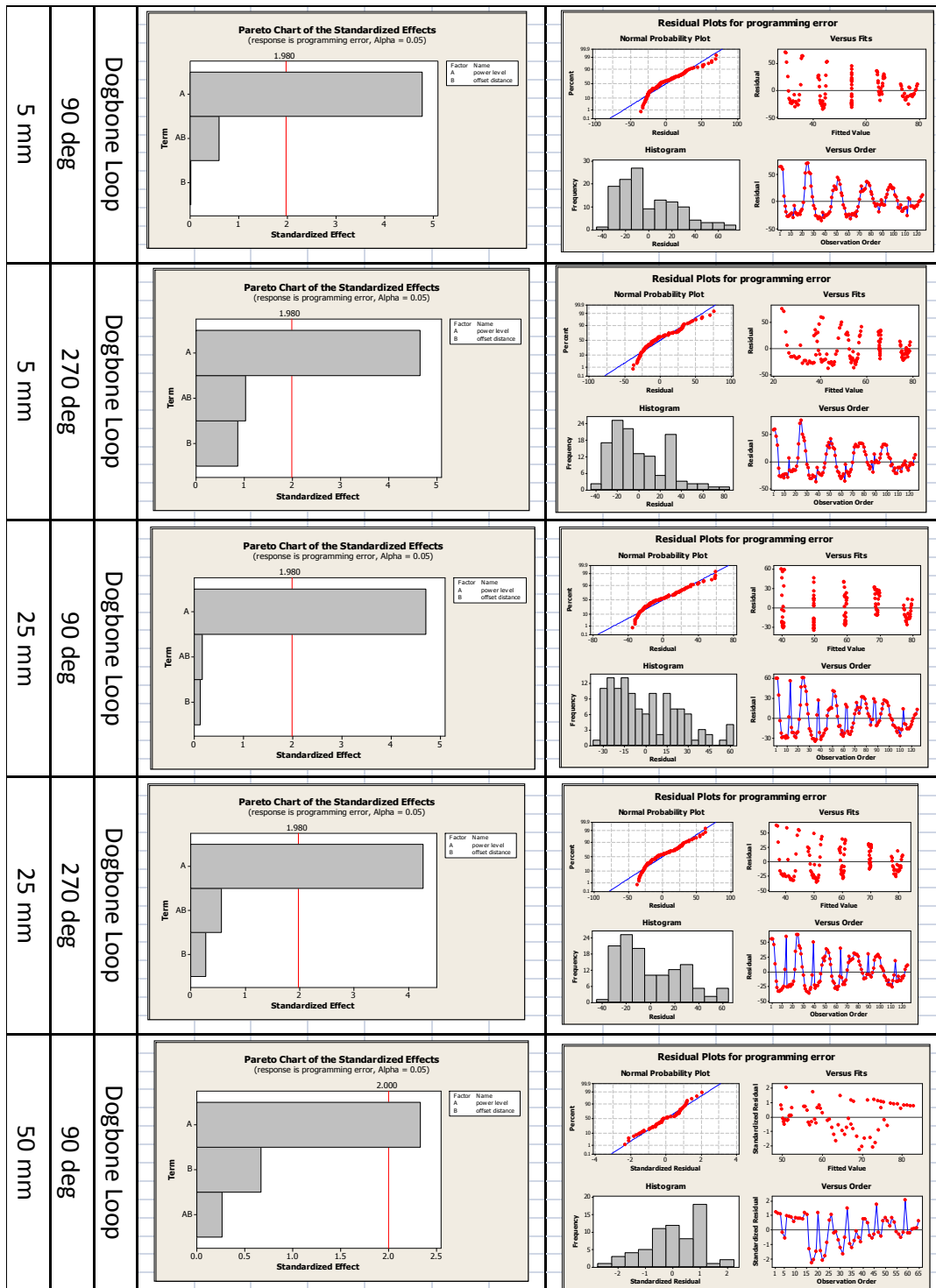


Figure E1: Static Offset Dogbone--Loop Pareto and residual charts

# Dogbone – Skyetek

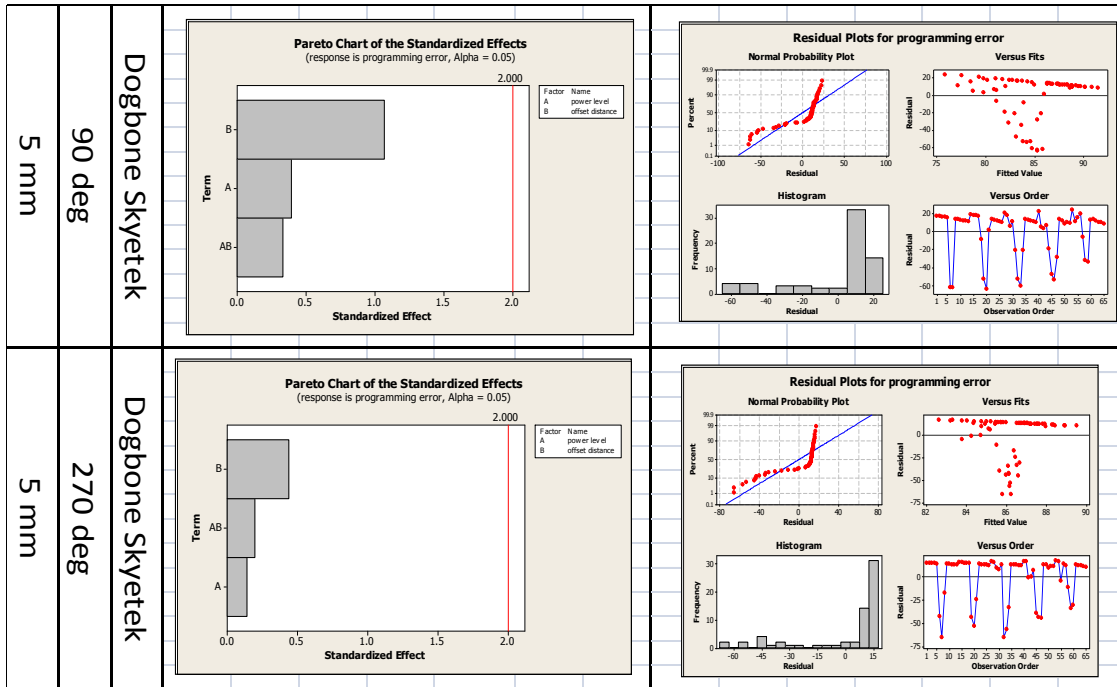


Figure E2: Static Offset Dogbone--Skyetek Pareto and residual charts

# F. Static Offset Data

## Dogbone

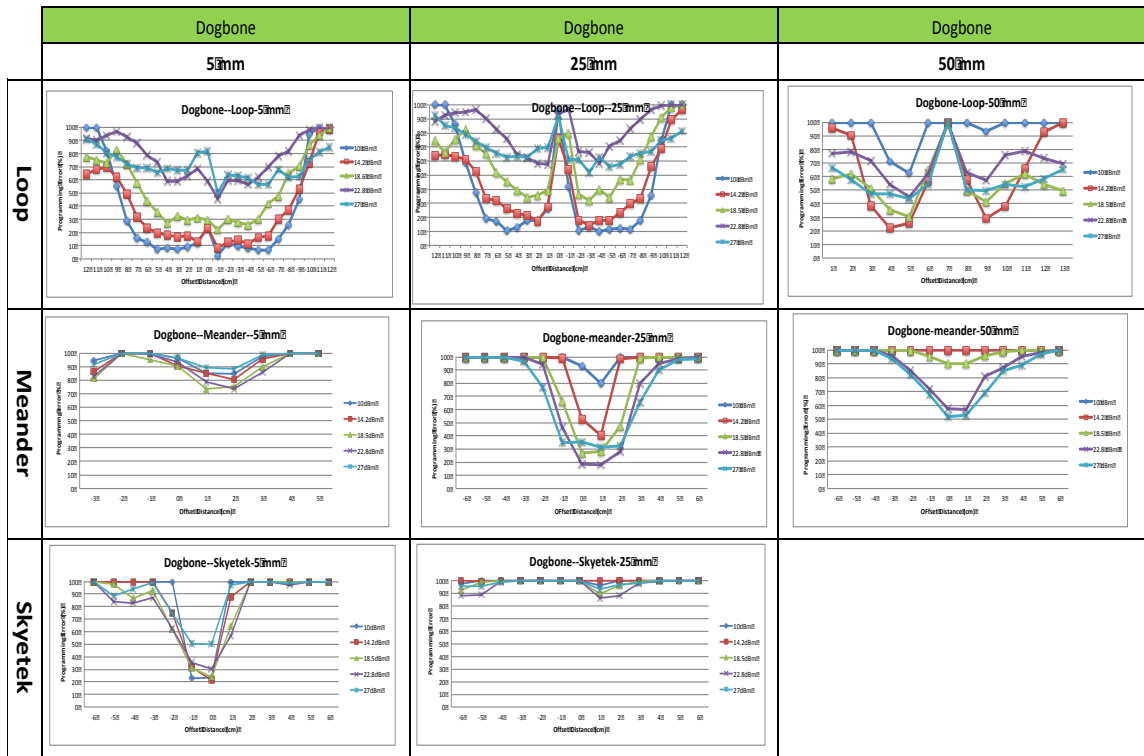


Figure F1: Static offset Dogbone Summary

## Slim Line

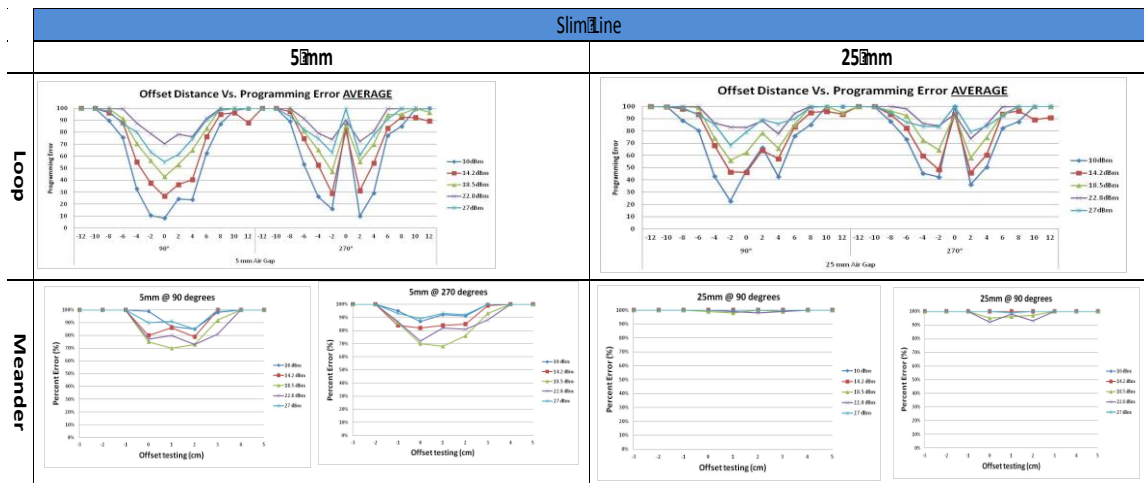


Figure F2: Static offset Slim Line summary

# Squigg

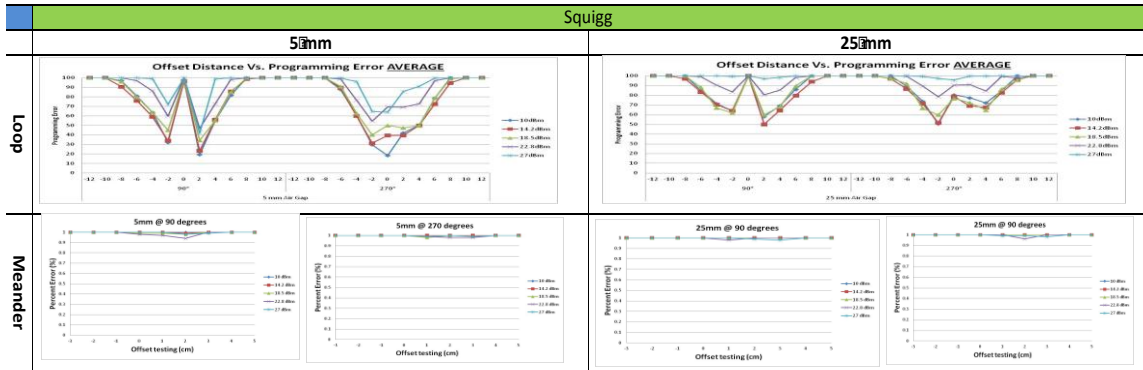


Figure F3: Static offset Squigg Summary



# Dogbone – Meander

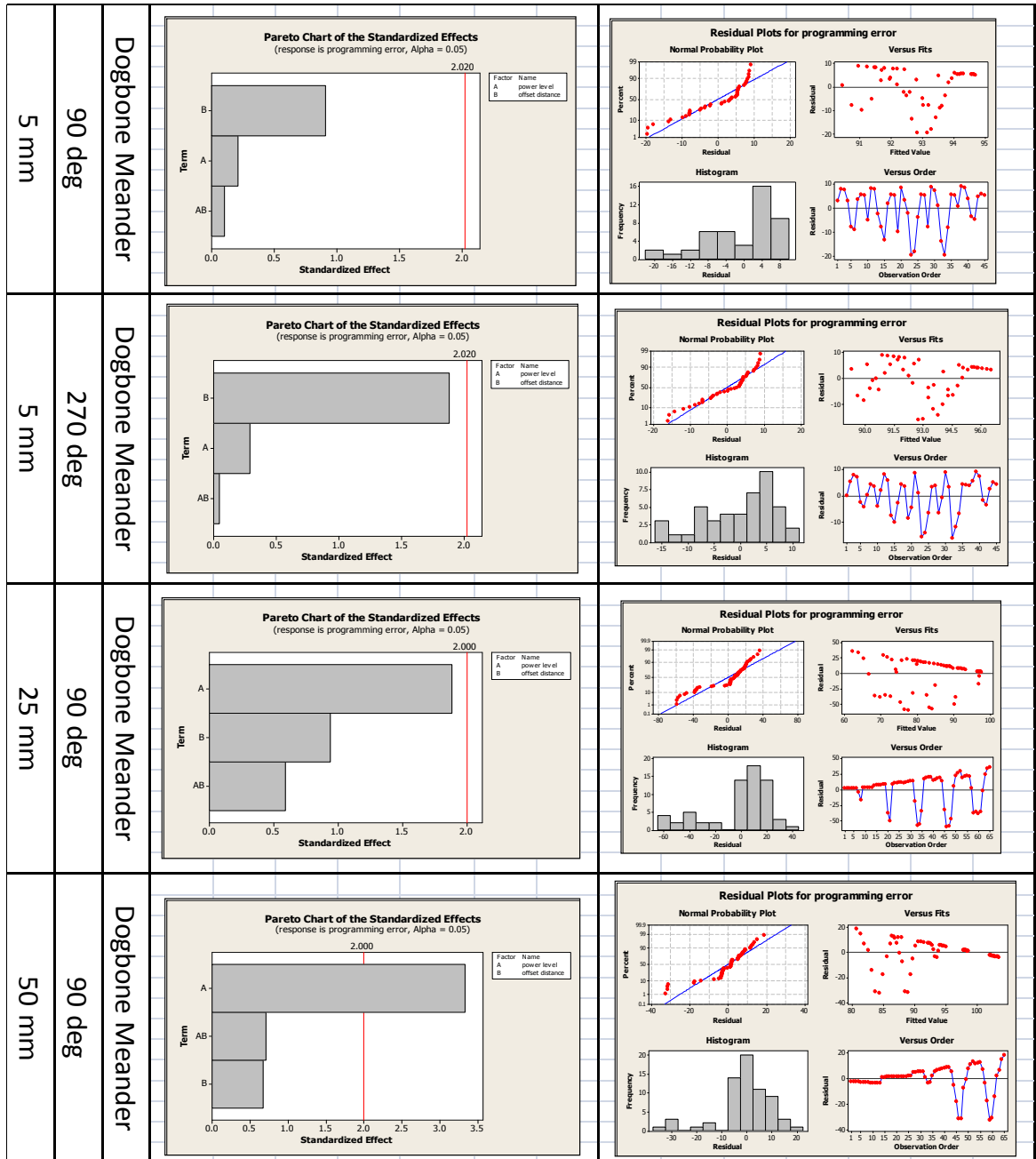


Figure F3: Static Offset Dogbone--Meander Pareto and residual charts

## G. Glossary of Terms

**Active tag:** An RFID tag that has a transmitter to send back information, rather than reflecting back a signal from the reader, as a passive tag does. Most active tags use a battery to transmit a signal to a reader. However, some tags can gather energy from other sources. Active tags can be read from 300 feet (100 meters) or more, but they're expensive (typically more than US\$20 each). They're used for tracking expensive items over long ranges. For instance, the U.S. military uses active tags to track containers of supplies arriving in ports.

**Addressability:** The ability to write data to different fields, or blocks of memory, in the microchip in an RFID transponder.

**Agile reader:** A generic term that usually refers to an RFID reader that can read tags operating at different frequencies or using different methods of communication between the tags and readers.

**Air interface protocol:** The rules that govern how tags and readers communicate.

**Alignment:** See Orientation.

**Amplitude:** The maximum absolute value of a periodic curve measured along its vertical axis (the height of a wave, in layman's terms).

**Amplitude modulation:** . Changing the amplitude of a radio wave. A higher wave is interpreted as a 1 and a normal wave is interpreted as a zero. By changing the wave, the RFID tag can communicate a string of binary digits to the reader. Computers can interpret these digits as digital information. The method of changing the amplitude is known as amplitude shift keying, or ASK.

**Antenna:** The tag antenna is the conductive element that enables the tag to send and receive data. Passive, low- (135 kHz) and high-frequency (13.56 MHz) tags usually have a coiled antenna that couples with the coiled antenna of the reader to form a magnetic field. UHF tag antennas can be a variety of shapes. Readers also have antennas which are used to emit radio waves. The RF energy from the reader antenna is "harvested" by the antenna and used to power up the microchip, which then changes the electrical load on the antenna to reflect back

its own signals.

**Antenna gain:** In technical terms, the gain is the ratio of the power required at the input of a loss-free reference antenna to the power supplied to the input of the given antenna to produce, in a given direction, the same field strength at the same distance. Antenna gain is usually expressed in decibels and the higher the gain the more powerful the energy output. Antennas with higher gain will be able to read tags from farther away.

**Anti-collision:** A general term used to cover methods of preventing radio waves from one device from interfering with radio waves from another. Anti-collision algorithms are also used to read more than one tag in the same reader's field.

**Auto-ID Center:** A non-profit collaboration between private companies and academia that pioneered the development of an Internet-like infrastructure for tracking goods globally through the use of RFID tags.

**Automatic Identification:** A broad term that covers methods of collecting data and entering it directly into computer systems without human involvement. Technologies normally considered part of auto-ID include bar codes, biometrics, RFID and voice recognition.

**Backscatter:** A method of communication between passive tags (ones that do not use batteries to broadcast a signal) and readers. RFID tags using backscatter technology reflect back to the reader radio waves from a reader, usually at the same carrier frequency. The reflected signal is modulated to transmit data.

**Bar code:** A standard method of identifying the manufacturer and product category of a particular item. The barcode was adopted in the 1970s because the bars were easier for machines to read than optical characters. Barcodes' main drawbacks are they don't identify unique items and scanners have to have line of sight to read them.

**Battery-assisted tag:** These are RFID tags with batteries, but they communicate using the same backscatter technique as passive tags (tags with no battery). They use the battery to run the circuitry on the microchip and sometimes an onboard sensor. They have a longer read range than a regular passive tag because all of the energy gathered from the reader can be reflected back to the

reader. They are sometimes called "semi-passive RFID tags."

**Carrier frequency:** The main frequency of a transmitter, or RFID reader, such as 915 MHz. The frequency is then changed, or modulated, to transmit information.

**Checksum:** A code added to the contents of a block of data stored on an RFID microchip that can be checked before and after data is transmitted from the tag to the reader to determine whether the data has been corrupted or lost. The cyclic redundancy check is one form of checksum.

**Chipless RFID tag:** An RFID tag that doesn't depend on a silicon microchip. Some chipless tags use plastic or conductive polymers instead of silicon-based microchips. Other chipless tags use materials that reflect back a portion of the radio waves beamed at them. A computer takes a snapshot of the waves beamed back and uses it like a fingerprint to identify the object with the tag. Companies are experimenting with embedding RF reflecting fibers in paper to prevent unauthorized photocopying of certain documents. Chipless tags that use embedded fibers have one drawback for supply chain uses—only one tag can be read at a time.

**Circular-polarized antenna:** A UHF reader antenna that emits radio waves in a circular pattern. These antennas are used in situations where the orientation of the tag to the reader cannot be controlled. Since the waves are moving in a circular pattern, they have a better chance of hitting the antenna, but circular-polarized antennas have a shorter read range than linear-polarized antennas.

**Closed-loop systems:** RFID tracking systems set up within a company. Since the tracked item never leaves the company's control, it does not need to worry about using technology based on open standards.

**Commissioning a tag:** This term is sometime used to refer to the process of writing a serial number to a tag (or programming a tag) and associating that number with the product it is put on in a database.

**Concentrator:** A device connected to several RFID readers to gather data from the readers. The concentrator usually performs some filtering and then passes only useful information from the readers on to a host computer.

**Contactless smart card:** An awkward name for a credit card or loyalty card that contains an RFID chip to transmit information to a reader without having to be swiped through a reader. Such cards can speed checkout, providing consumers with more convenience.

**Coupling:** See inductive coupling

**Cyclic redundancy check (CRC):** A method of checking data stored on an RFID tag to be sure that it hasn't been corrupted or some of it lost. (See Checksum.)

**Data transfer rate:** The number of characters that can be transferred from an RFID tag to a reader within a given time. Baud rates are also used to quantify how fast readers can read the information on the RFID tag. This differs from read rate, which refers to how many tags can be read within a given period of time.

**Data field:** An area of memory on an RFID microchips that is assigned to a particular type of information. Data fields may be protected (see below) or they may be written over, so a data field might contain information about where an item should be sent to. When the destination changes, the new information is written to the data field.

**Data field protection:** The ability to prevent data stored in a specific area of memory of an RFID microchip from being overwritten. Companies might want to protect the data field that stores an Electronic Product Code, which doesn't change during the life of the product it's associated with.

**Decibel (dB):** A measure of the gain of an antenna.

**De-tune:** UHF antennas are tuned to receive RFID waves of a certain length from a reader, just as the tuner on the radio in a car changes the antenna to receive signals of different frequencies. When UHF antenna is close to metal or metallic material, the antenna can be detuned, resulting in poor performance.

**Die:** The silicon block onto which circuits have been etched to create a microchip.

**Duplex:** A channel capable of transmitting data in both directions at the same time. (Half duplex is a channel capable of transmitting data in both directions, but not simultaneously.)

**Duty cycle:** The length of time the reader can be emitting energy. Regulations in the European Union say readers can be on only 10 percent of the time.

**EEPROM (Electrically Erasable Programmable Read-Only Memory):** A method of storing data on microchips. Usually bytes can be erased and reprogrammed individually. RFID tags that use EEPROM are more expensive than factory programmed tags, where the number is written into the silicon when the chip is made, but they offer more flexibility because the end user can write an ID number to the tag at the time the tag is going to be used.

**Effective isotropic radiated power (EIRP):** A measurement of the output of RFID reader antennas used in the United States and elsewhere. EIRP is usually expressed in watts.

**Effective radiated power (ERP):** A measurement of the output of RFID reader antennas used in Europe and elsewhere. ERP is usually expressed in watts and is not the same as EIRP.

**Electromagnetic interference (EMI):** Interference caused when the radio waves of one device distort the waves of another. Cell phones, wireless computers and even robots in factories can produce radio waves that interfere with RFID tags.

**Electronic article surveillance (EAS):** Simple electronic tags that can be turned on or off. When an item is purchased (or borrowed from a library), the tag is turned off. When someone passes a gate area holding an item with a tag that hasn't been turned off, an alarm sounds. EAS tags are embedded in the packaging of most pharmaceuticals. They can be RF-based, or acousto-magnetic.

**Electronic Product Code: (EPC):** A serial, created by the Auto-ID Center, that will complement barcodes. The EPC has digits to identify the manufacturer, product category and the individual item.

**EPC Discovery Service:** An EPCglobal Network service that allows companies to search for every reader that has read a particular EPC tag.

**EPCglobal:** A non-profit organization set up the Uniform Code Council and EAN International, the two organizations that maintain barcode standards, to commercialize EPC technology. EPCglobal is made up of chapters in different countries and regions. It is commercializing the technology originally developed by the Auto-ID Center.

**EPC Information Service:** Part of the EPC Network. The EPC Information Service is a network infrastructure that enables companies to store data associated with EPCs in secure databases on the Web. The EPC Information Service will enable companies to provide different levels of access to data to different groups. Some information associated with an EPC might be available to everyone. Other information might be available only to a manufacturer's retail customers. The service also includes a number of applications, such as the EPC Discovery Service.

**EPCglobal Network (or EPC Network):** The Internet-based technologies and services that enable companies to retrieve data associated with EPCs. The network infrastructure includes the Object Name Service, distributed middleware (sometimes called Savants), the EPC Information Service and Physical Markup Language.

**Error correcting code:** A code stored on an RFID tag to enable the reader to figure out the value of missing or garbled bits of data. It's needed because a reader might misinterpret some data from the tag and think a Rolex watch is actually a pair of socks.

**Error correcting mode:** A mode of data transmission between the tag and reader in which errors or missing data is automatically corrected.

**Error correcting protocol:** A set of rules used by readers to interpret data correctly from the tag.

**European Article Numbering (EAN):** The bar code standard used throughout Europe, Asia and South America. It is administered by EAN International.

**Excite:** The reader is said to "excite" a passive tag when the reader transmits RF energy to wake up the tag and enable it to transmit back.

**eXtensible markup language (XML):** A widely accepted way of sharing information over the Internet in a way that computers can use, regardless of their operating system.

**European Telecommunications Standards Institute (ETSI):** The European Union body that recommends standards for adoption by member countries.

**Factory programming:** Some read-only have to have their identification number written into the silicon microchip at the time the chip is made. The process of writing the number into the chip is called factory programming. This data can't be written over or changed.

**Far-field communication:** RFID reader antennas emit electromagnetic radiation (radio waves). If an RFID tag is outside of one full wavelength of the reader, it is said to be in the "far field." If it is within one full wavelength away, it is said to be in the "near field." The far field signal decays as the square of the distance from the antenna, while the near field signal decays as the cube of distance from the antenna. So passive RFID systems that rely on far field communications (typically UHF and microwave systems) have a longer read range than those that use near field communications (typically low- and high-frequency systems).

**Field programming:** Tags that use EEPROM, or non-volatile memory, can be programmed after it is shipped from the factory. That is, users can write data to the tag when it is placed on a product.

**Fluidic Self-Assembly:** A manufacturing process, patented by Alien Technology. It involves flowing tiny microchips in a special fluid over a base with holes shaped to catch the chips. The process is designed to mass assemble billions of RFID tags at very low cost.

**Frequency:** The number of repetitions of a complete wave within one second. 1 Hz equals one complete waveform in one second. 1 KHz equals 1,000 waves in a second. RFID tags use low, high, ultra-high and microwave frequencies. Each frequency has advantages and disadvantages that make them more suitable for some applications than for others.

**Frequency hopping:** A technique used to prevent readers from interfering with



one another. In the United States, UHF RFID readers actually operate between 902 and 928 MHz, even though it is said that they operate at 915 MHz. The readers may jump randomly or in a programmed sequence to any frequency between 902 MHz and 928 MHz. If the band is wide enough, the chances of two readers operating at exactly the same frequency is small. The UHF bands in Europe and Japan are much smaller so this technique is not effective for preventing reader interference.

**Gain:** See Antenna gain.

**GTAG (Global Tag):** A standardization initiative of the Uniform Code Council (UCC) and the European Article Numbering Association (EAN) for asset tracking and logistics based on radio frequency identification (RFID). The GTAG initiative was supported by Philips Semiconductors, Intermec, and Gemplus, three major RFID tag makers. But it was superseded by the Electronic Product Code.

**Harvesting:** A term sometimes used to describe the way passive tags gather energy from an RFID reader antenna.

**High-frequency:** From 3 MHz to 30 MHz. HF RFID tags typically operate at 13.56 MHz. They typically can be read from less than 3 feet away and transmit data faster than low-frequency tags. But they consume more power than low-frequency tags.

**Inductive coupling:** A method of transmitting data between tags and readers in which the antenna from the reader picks up changes in the tag's antenna.

**Industrial, Scientific, and Medical (ISM) bands:** A group of unlicensed frequencies of the electromagnetic spectrum.

**Inlay:** An RFID microchip attached to an antenna and mounted on a substrate. Inlays are essentially unfinished RFID labels. They are usually sold to label converters who turn them into smart labels.

**Integrated circuit (IC):** A microelectronic semiconductor device comprising many interconnected transistors and other components. Most RFID tags have ICs.

**Input/output (I/O):** Ports on a reader. Users can connect devices, such as an electronic eye to the input port so that when an object breaks the beam of the

electronic eye the reader begins reading. Devices can also be connected to an output part, so that when a tag is read, a conveyor is turned on or a dock door opened.

**Interrogator:** See Reader.

**Licence plate:** This term generally applies to a simple RFID that has only a serial number that is associated with information in a database. The Auto-ID Center promoted the concept as a way to simplify the tag and reduce the cost.

**Linear-polarized antenna:** A UHF antenna that focuses the radio energy from the reader in a narrow beam. This increases the read distance possible and provides greater penetration through dense materials. Tags designed to be used with a linear polarized reader antenna must be aligned with the reader antenna in order to be read.

**Low-frequency:** From 30 kHz to 300 kHz. Low-frequency tags typical operate at 125 kHz or 134 kHz. The main disadvantages of low-frequency tags are they have to be read from within three feet and the rate of data transfer is slow. But they are less subject to interference than UHF tags.

**Memory:** The amount of data that can be stored on the microchip in an RFID tag.

**Memory block:** Memory on the microchip in an RFID tag is usually divided into sections, which can be read or written to individually. Some blocks might be locked, so data can't be overwritten, while others are not.

**Microwave tags:** A term that is some time used to refer to RFID tags that operate at 5.8 GHz. They have very high transfer rates and can be read from as far as 30 feet away, but they use a lot of power and are expensive. (Some people refer to any tag that operates above about 415 MHz as a microwave tag.)

**Modulation:** Changing the radio waves traveling between the reader and the transponder in ways that enable the transmission of information. Waves be changed in a variety of ways that can be picked up by the reader and turned into the ones and zeroes of binary code. Waves can be made higher or lower (amplitude modulation) or shifted forward (phase modulation).

The frequency can be varied (frequency modulation), or data can be contained in

the duration of pulses (pulse-width modulation).

**Multiple access schemes:** Methods of increasing the amount of data that can be transmitted wirelessly within the same frequency spectrum. Some RFID readers use Time Division Multiple Access, or TDMA, meaning they read tags at different times to avoid interfering with one another.

**Multiplexer:** An electronic device that allows a reader to have more than one antenna. Each antenna scans the field in a preset order. This reduces the number of readers needed to cover a given area, such as a dock door, and prevents the antennas from interfering with one another.

**NanoBlock:** The term Alien Technology uses to describe its tiny microchips, which are about the width of three human hairs.

**Near-field communication:** RFID reader antennas emit electromagnetic radiation (radio waves). If an RFID tag is within full wavelength of the reader, it is said to be in the "near field." If it is more than the distance of one full wavelength away, it is said to be in the "far field." The near field signal decays as the cube of distance from the antenna, while the far field signal decays as the square of the distance from the antenna. So passive RFID systems that rely on near-field communication (typically low- and high-frequency systems) have a shorter read range than those that use far field communication (UHF and microwave systems).

**Noise:** Unwanted ambient electrical signals or electromagnetic energy found in the operating environment of RFID equipment. Noise can be caused by other RF devices, robots, electric motors and other machines.

**Nominal range:** The read range at which the tag can be read reliably.

**Null spot:** Area in the reader field that doesn't receive radio waves. This is essentially the reader's blind spot. It is a phenomenon common to UHF systems.

**Object Name Service (ONS):** An Auto-ID Center-designed system for looking up unique Electronic Product Codes and pointing computers to information about the item associated with the code. ONS is similar to the Domain Name Service, which points computers to sites on the Internet.

**One-time programmable tag:** Also called a field-programmable tag. An RFID tag that can be written to once and read many times (seeWORM).

**Orientation:** The position of a tag antenna vis-a-vis a reader antenna. With UHF systems, readers can be either circular-polarized or linear-polarized. When using a linear polarized antenna, the tag reader and antenna reader must be in alignment in order to achieve the longest reading distance. If that tag antenna is aligned vertically and the reader is sending out signals horizontally, only a small portion of the energy emitted by the reader will hit the tag antenna.

**Passive tag:** An RFID tag without a battery. When radio waves from the reader reach the chip's antenna, the energy is converted by the antenna into electricity that can power up the microchip in the tag. The tag is able to send back information stored on the chip. Today, simple passive tags cost from U.S. 20 cents to several dollars, depending on the amount of memory on the tag and other features.

**Patch antenna:** A small square reader antenna made from a solid piece of metal or foil.

**Penetration:** The ability of a particular radio frequency to pass through non-metallic materials. Low-frequency systems have better penetration than UHF systems.

**Phantom read (also called a phantom transaction or false read):** When a reader reports the presence of a tag that doesn't exist.

**Physical Markup Language (PML):** An Auto-ID Center-designed method of describing products in a way computers can understand. PML is based on the widely accepted eXtensible Markup Language used to share data over the Internet in a format all computers can use. The idea is to create a computer language that companies can use to describe products so that computer can search for, say, all "softdrinks" in inventory.

**PML Server:** A server that responds to requests for Physical Markup Language (PML) files related to individual Electronic Product Codes. The PML files and servers will be maintained by the manufacturer of the item. The name PML

server has been replaced by EPC Information Service.

**Power level:** The amount of RF energy radiated from a reader or an active tag. The higher the power output, the longer the read range, but most governments regulate power levels to avoid interference with other devices.

**Programming a tag:** Writing data to an RFID tag. This is sometimes called "commissioning a tag."

**Protocol:** A set of rules that govern communications systems. (See Air-interface protocol.)

**Proximity sensor:** A device that detects the presence of an object and signals another device. Proximity sensors are often used on manufacturing lines to alert robots or routing devices on a conveyor to the presence of an object. They can be used in RFID systems to turn on readers.

**Radio Frequency Identification (RFID):** A method of identifying unique items using radio waves. Typically, a reader communicates with a tag, which holds digital information in a microchip. But there are chipless forms of RFID tags that use material to reflect back a portion of the radio waves beamed at them.

**Range:** See read range.

**Read:** The process of retrieving data stored on an RFID tag by sending radio waves to the tag and converting the waves the tag sends back into data.

**Reader:** A device used to communicate with RFID tags. The reader has one or more antennas, which emit radio waves and receive signals back from the tag. The reader is also sometimes called an interrogator because it "interrogates" the tag.

**Reader (also called an interrogator):** The reader communicates with the RFID tag via radio waves and passes the information in digital form to a computer system.

**Reader field:** The area of coverage. Tags outside the reader field do not receive

radio waves and can't be read.

**Read-only tags:** Tags that contain data that cannot be changed unless the microchip is reprogrammed electronically.

**Reader talks first:** A means by which a passive UHF reader communicates with tags in its read field. The reader sends energy to the tags but the tags sit idle until the reader requests them to respond. The reader is able to find tags with specific serial numbers by asking all tags with a serial number that starts with either 1 or 0 to respond. If more than one responds, the reader might ask for all tags with a serial number that starts with 01 to respond, and then 010. This is called "walking" a binary tree, or "tree walking." (See Singulation.)

**Read range:** The distance from which a reader can communicate with a tag. Active tags have a longer read range than passive tags because they use a battery to transmit signals to the reader. With passive tags, the read range is influenced by frequency, reader output power, antenna design, and method of powering up the tag. Low frequency tags use inductive coupling (see above), which requires the tag to be within a few feet of the reader.

**Read rate:** Often used to describe the number of tags that can be read within a given period. The read rate can also mean the maximum rate at which data can be read from a tag expressed in bits or bytes per second. (See Data transfer rate.)

**Read-write tag:** an RFID tag that can store new information on its microchip. These tags are often used on reusable containers and other assets. When the contents of the container are changed, new information is written to the tag. Read-write tags are more expensive than read-only tags.

**RFID tag:** A microchip attached to an antenna that is packaged in a way that it can be applied to an object. The tag picks up signals from and sends signals to a reader. The tag contains a unique serial number, but may have other information, such as a customer's account number. Tags come in many forms, such as smart labels that can have a barcode printed on it, or the tag can simply be mounted inside a carton or embedded in plastic. RFID tags can be active, passive or semi-passive.

**Scanner:** An electronic device that can send and receive radio waves. When combined with a digital signal processor that turns the waves into bits of information, the scanner is called a reader or interrogator.

**Savants:** Middleware created by the Auto-ID Center to filter data from EPC readers and pass it on to enterprise systems. It was envisioned that Savants would reside on servers across the EPC Network and pass data to one another and act as a kind of nervous system for the network. The term is being phased out by EPCglobal and many of the functions of Savants are being incorporated in commercial middleware products.

**Semi-passive tag:** Similar to active tags, but the battery is used to run the microchip's circuitry but not to broadcast a signal to the reader. Some semi-passive tags sleep until they are woken up by a signal from the reader, which conserves battery life. Semi-passive tags can cost a dollar or more. These tags are sometimes called battery-assisted tags.

**Sensor:** A device that responds to a physical stimulus and produces an electronic signal. Sensors are increasingly being combined with RFID tags to detect the presence of a stimulus at an identifiable location.

**Silent Commerce:** This term covers all business solutions enabled by tagging, tracking, sensing and other technologies, including RFID, which make everyday objects intelligent and interactive. When combined with continuous and pervasive Internet connectivity, they form a new infrastructure that enables companies to collect data and deliver services without human interaction.

**Signal attenuation:** The weakening of RF energy from an RFID tag or reader. Water absorbs UHF energy, causing signal attenuation.

**Singulation:** A means by which an RFID reader identifies a tag with a specific serial number from a number of tags in its field. There are different methods of singulation, but the most common is "tree walking", which involves asking all tags with a serial number that starts with either a 1 or 0 to respond. If more than one responds, the reader might ask for all tags with a serial number that starts with 01 to respond, and then 010. It keeps doing this until it finds the tag it is looking for. (See Reader talks first.)

**Smart label:** A generic term that usually refers to a barcode label that contains an RFID transponder. It's considered "smart" because it can store information, such as a unique serial number, and communicate with a reader.

**Smart cards:** See Contactless smart cards.

**SAW (Surface Acoustic Wave):** A technology used for automatic identification in which low power microwave radio frequency signals are converted to ultrasonic acoustic signals by a piezoelectric crystalline material in the transponder. Variations in the reflected signal can be used to provide a unique identity.

**Synchronization:** Timing readers or reader antennas near one another so that they don't interfere with one another.

**Tag:** See RFID tag

**Tag talks first:** A means by which a reader in a passive UHF system identifies tags in the field. When tags enter the reader's field, they immediately communicate their presence by reflecting back a signal. This is useful when you want to know everything that is passing a reader, such as when items are moving quickly on a conveyor. In other cases, the reader wants to simply find specific tags in a field, in which case it wants to broadcast a signal and have only certain tags respond. (See Reader talks first.)

**Time Division Multiple Access (TDMA):** A method of solving the problem of the signals of two readers colliding. Algorithms are used to make sure the readers attempt to read tags at different times.

**Transceiver:** A device that both transmits and receives radio waves.

**Transponder:** A radio transmitter–receiver that is activated when it receives a predetermined signal. RFID transponders come in many forms, including smart labels, simple tags, smart cards and keychain fobs. RFID tags are sometimes referred to as transponders.

**Ultra–high frequency (UHF):** From 300 MHz to 3 Ghz. Typically, RFID tags that operate between 866 MHz to 960 MHz. They can send information faster and farther than high– and low–frequency tags. But radio waves don't pass through



items with high water content, such as fruit, at these frequencies. UHF tags are also more expensive than low-frequency tags, and they use more power.

**Uniform Code Council (UCC):** The nonprofit organization that oversees the Uniform Product Code, the barcode standard used in North America.

**Unique Identifier (UID):** A serial number that identifies the transponder. The U.S. Department of Defense has also developed an identification scheme called UID.

**Universal Product Code (UPC):** The barcode standard used in North America. It is administered by the Uniform Code Council.

**WORM:** Write once, read many. A tag that can be written to only once by the user. Thereafter, the tag can only be read.

**Write rate:** The rate at which information is transferred to a tag, written into the tag's memory and verified as being correct.

**XML:** See eXtensible Markup Language.

**XML Query Language (XQL):** A method of searching a database based on the extensible markup language (XML). Files created using the Auto-ID Center's Physical Markup Language can be searched using XQL.

## References

- [1] Munarriz, “RFID Signal Strong in 2005”, The Motley Fool. January 3, 2005. Retrieved from <http://www.fool.com/news/mft/2005/mft05010303.htm>
- [2] Swedberg, “RFID to Revolutionize Coca-Cola’s Dispensers”, RFID Journal. June 10, 2009. Retrieved from <http://www.rfidjournal.com/articles/view?4967>
- [3] Nelson, “Brewing UP Better Sales and Service”, Impinj Case Study. 2011. Retrieved from [http://c.ymcdn.com/sites/www.aimglobal.org/resource/resmgr/casestudies/cs\\_impinj\\_pub\\_tavernrestaura.pdf](http://c.ymcdn.com/sites/www.aimglobal.org/resource/resmgr/casestudies/cs_impinj_pub_tavernrestaura.pdf)
- [4] Swedberg, “Love’s Tries RFID for Automating Fuel Payments”, RFID Journal, September 9, 2011. Retrieved from <http://www.rfidjournal.com/articles/view?8761>
- [5] Impinj, “Health Safety: Hanmi Pharmaceutical”, Impinj Case Study. 2011.
- [6] Impinj, “Banking on RFID: Agricultural Bank of China”, Impinj Case Study. 2011. Retrieved from [http://c.ymcdn.com/sites/www.aimglobal.org/resource/resmgr/casestudies/cs\\_impinj\\_agricultural\\_bank\\_.pdf](http://c.ymcdn.com/sites/www.aimglobal.org/resource/resmgr/casestudies/cs_impinj_agricultural_bank_.pdf)
- [7] Bolic, Simplot-Ryl, & Stojmenovic, “RFID Systems: Research Trends and Challenges”, July 5, 2010.
- [8] Aroor, Deavours, “ Evaluation of the State of Passive UHF RFID: An Experimental Approach”, December 2007. [Online]. Available: <http://www.ittc.ku.edu/~deavours/pubs/ieeesystems07.pdf>
- [9] Ward, Alien Technologies, “An Introduction to RFID Technology”, September 2002
- [10] McCarthy, Ayalew, Butler, McDonnell, Ward, “The Effects of item composition, tag inlay design, reader antenna polarization, power and transponder orientation on the dynamic coupling efficiency of backscatter ultra high frequency radio frequency identification”, July 2009
- [11] Clarke, Twede, Tazelaar, Boyer, “Operations and Supply Chain Management for the 21<sup>st</sup> century”, 2005
- [12] “Radio Link Budgets For 915 MHz RFID Antennas Placed on Various Objects”, October 2005.
- [13] McCarthy, Ayalew, Butler, McDonnell, & Ward, “A note on UHF tagging and Scot EID”, 2009
- [14] Wyld, “RFID: Right Frequency for Government”, October 2005. Retrieved from [http://ok-safe.com/files/documents/1/RFID\\_The\\_Right\\_Frequency\\_for\\_Government\\_IBM.pdf](http://ok-safe.com/files/documents/1/RFID_The_Right_Frequency_for_Government_IBM.pdf)

- [15] Bauer, Fabian, Fischmann, Gurses, "Emerging Markets for RFID Traces", June 5, 2006. Retrieved from <http://arxiv.org/pdf/cs/0606018v1.pdf>
- [16] B. Joseph Pine II, Bart Victor, and Andrew C. Boynton, "Making mass customization work". September-October 1993. Retrieved from
- [17] Violino, "The History of RFID Technology", RFID Journal. January 16, 2005. Retrieved from <http://www.rfidjournal.com/articles/view?1338>
- [18] Mroz Consulting, "RFID: A Primer on the Imminent Revolution in Supply Chain Management", March 2005. Retrieved from <http://www.mrozconsulting.com/rfid%20primer.html>.
- [19] Brown, "Revolution at the Checkout Counter: The Explosion of the Bar Code", Werhemium Publications in Industrial Relations, 1997.
- [20] Bonsor, "How Smart Labels Will Work", How Stuff Works, September 2003. Retrieved from [http://www.electronics.howstuffworks.com/smart\\_label.htm.printable](http://www.electronics.howstuffworks.com/smart_label.htm.printable).
- [21] Douglas, "Bar Codes vs. RFID", February 2005. Retrieved from: <http://www.globeltechnology.com,servlet/story/RTGAM.2005011.gtfbarcodejan11/BNstory/Technology/>.
- [22] Impinj, "Banking on RFID: Agricultural Bank of China", Impinj Case Study. 2011. Retrieved from [http://c.ymcdn.com/sites/www.aimglobal.org/resource/resmgr/casestudies/cs\\_impinj\\_agricultural\\_bank\\_.pdf](http://c.ymcdn.com/sites/www.aimglobal.org/resource/resmgr/casestudies/cs_impinj_agricultural_bank_.pdf)
- [23] Fox and Rychak, "A Call to Action: The Fourth Amendment, the Future of Radio Frequency Identification, and Society", 2004. Retrieved from [http://digitalcommons.lmu.edu/cgi/viewcontent.cgi?article=1043&context=llr\\_symposia](http://digitalcommons.lmu.edu/cgi/viewcontent.cgi?article=1043&context=llr_symposia)
- [24] Wyld, "RFID: Right Frequency for Government", October 2005. Retrieved from [http://ok-safe.com/files/documents/1/RFID\\_The\\_Right\\_Frequency\\_for\\_Government\\_IBM.pdf](http://ok-safe.com/files/documents/1/RFID_The_Right_Frequency_for_Government_IBM.pdf)
- [25] Harrop, Das, "RFID Forecasts, Players and Opporunities 2012-2022", March 2013
- [26] Swedberg, "RFID to Revolutionize Coca-Cola's Dispensers", RFID Journal. June 10, 2009. Retrieved from <http://www.rfidjournal.com/articles/view?4967>
- [27] Nelson, "Brewing UP Better Sales and Service", Impinj Case Study. 2011. Retrieved from [http://c.ymcdn.com/sites/www.aimglobal.org/resource/resmgr/casestudies/cs\\_impinj\\_pub\\_tavernrestaura.pdf](http://c.ymcdn.com/sites/www.aimglobal.org/resource/resmgr/casestudies/cs_impinj_pub_tavernrestaura.pdf)
- [28] Swedberg, "Love's Tries RFID for Automating Fuel Payments", RFID Journal, September 9, 2011. Retrieved from <http://www.rfidjournal.com/articles/view?8761>
- [29] Impinj, "Health Safety: Hanmi Pharmaceutical", Impinj Case Study. 2011.

- [30] Impinj, “Banking on RFID: Agricultural Bank of China”, Impinj Case Study. 2011. Retrieved from [http:// c.ymcdn.com/sites/www.aimglobal.org/resource/resmgr/casestudies/cs\\_impinj\\_agricultural\\_bank\\_.pdf](http://c.ymcdn.com/sites/www.aimglobal.org/resource/resmgr/casestudies/cs_impinj_agricultural_bank_.pdf)
- [31] RX900 spec sheet, primaralabel.com
- [32] K. Koski, E. Koski, Virtanen, Bjorninen, Sydanheimo, Ukkonen, Elsherbeni, “Inkjet-printed passive UHF RFID tags: Review and performance evaluation”, November 2011.
- [33] Yang, Rida, Vyas, Tentzeris, “RFID Tag and RF Structures on a Paper Substrate Using Inkjet-printing Technology”, December 2007.
- [34] White paper “Solving the New Technology Requirements for RFID Business Applications: How Laser Printers Technologies are Adding Value To an Evolving Business Landscape”, 2009.
- [35] White paper “Solving the New Technology Requirements for RFID Business Applications: How Laser Printers Technologies are Adding Value To an Evolving Business Landscape”, 2009.
- [36] Department of Homeland Security (DHS), “Smart Border Alliance, RFID Feasibility Study Final Report”, 2009
- [37] Nikitin, Rao, “Antenna and Propagation in UHF RFID Systems”, April 2008
- [38] Rudge, Milne, Olver, Knight, “The Handbook of Antenna Design, Volume 1”, 1982
- [39] Donohoe, “Antenna Theory – Radiation Patterns”, 2011
- [40] Bhavsar, Blas, Hguyen, “Measurement of Antenna Radiation Patterns – Laboratory Manual”, 2000
- [41] Cisco White Paper, “Antenna Patterns and Their Meaning”, 2007
- [42] Cheung, Kwong, “RFID Reader Antennas”, 2007
- [43] Donohoe, “Antenna Theory – Radiation Patterns”, 2011
- [44] Orban, Moernaut, “The Basics of Patch Antennas”, 2011
- [45] Ibrahim, Uagoub, Habash, “Microstrip Patch Antenna for RFID Applications”, 2009
- [46] Xing, Wang, Wu, Huang, “Near Field Antenna Investigation and Evaluation for UHF RFID systems”, March, 2010.
- [47] Lee, “RFID Coil Design – AN678”, 1998
- [48] Yang, Basat, Tentzeris, “Design and Development of Novel Inductively Coupled RFID Antenna”, 2008

- [49] Choo, Ling, “Design of electrically small planer antenna using an inductively coupled feed”, October 2003
- [50] Rao, Niktin, Lam, “Antenna Design for UHF RFID tags: A review and practical application”, December 2005
- [51] Yang, Basat, Tentzeris, “Design and Development of Novel Inductively Coupled RFID Antenna”, 2008
- [52] Impinj, “Paper Clip Specification Sheet”, 2013
- [53] Rao, Niktin, Lam, “Antenna Design for UHF RFID tags: A review and practical application”, December, 2005
- [54] Wyld, “RFID: Right Frequency for Government”, October 2005. Retrieved from [http://ok-safe.com/files/documents/1/RFID\\_The\\_Right\\_Frequency\\_for\\_Government\\_IBM.pdf](http://ok-safe.com/files/documents/1/RFID_The_Right_Frequency_for_Government_IBM.pdf)
- [55] Alien Whitepaper, “RFID: From Pilots to Production – A look at the state of the RFID industry”, 2009
- [56] Occupational Safety & Health Administration, “Electromagnetic Radiation”, May 1990
- [57] Weis, “RFID (Radio Frequency Identification): Principles and Applications”, 2007
- [58] Mitchell, Alien Technology Whitepaper, “The Art and Science of UHF Passive Tag Design – And Selecting the Tag That is Best for Your Requirements”, June 6, 2013
- [59] Rudge, Milne, Olver, Knight, “The Handbook of Antenna Design, Volume 1”, 1982
- [60] Cisco White Paper, “Antenna Patterns and Their Meaning”, 2007
- [61] Cheung, Kwong, “RFID Reader Antennas”, 2007
- [62] Wheeler, Fellow, Ire, ”The Radiansphere Around a Small Antenna”, 1959
- [63] Donohoe, “Antenna Theory – Radiation Patterns”, 2011
- [64] Cisco White Paper, “RFID Tag Considerations – RFID Tag Technology”, 2001
- [65] Cheung, Kwong, “RFID Reader Antennas”, 2007
- [66] Zhang, Jia, Zhang, Wang, “Design of Antennas for RFID Application”, February 2009
- [67] Finkenzeller, “RFID Handbook”, March 1998
- [68] Lee, “RFID Coil Design – AN678”, 1998

- [69] Yang, Basat, Tentzeris, “Design and Development of Novel Inductively Coupled RFID Antenna”, 2008
- [70] Nikitin, Rao, “LabView-Based UHF RFID Tag Test and Measurement System”, July 2009
- [71] Nikitin, Rao, Lazar, “An Overview of Near Field UHF RFID”, February 2007
- [72] Inciting, Rao, Lam, “UHF RFID Tag Characterization: Overview and State-of-the-Art”, 2012
- [73] Ajitha, Bhanumathi, “Improving RFID Tag Efficiency by QAM Backscatter Modulating”, April 2013
- [74] Jang, “Hardware Design and Deployment Issues in UHF RFID Systems”, February 2010
- [75] Nikitin, Ramamurthy, Martinez, Rao, “Passive Tag-to-Tag Communication”, 2012
- [76] Griffin, Durgin, Haldi, Kippelen, “Radio Link Budgets for 915 MHZ RFID Antennas Placed on Various Objects”, 2012
- [77] Lazaro, Girbau, Villarino, “Effects of Interferences in UHF RFID Systems”, 2009
- [78] Adair, “Radio Frequency Identification (RFID) Power Budgets for Packaging Applications”, November 2005
- [79] Nikitin, Rao, “Theory and Measurement of Backscattering from RFID Tags”, 2006
- [80] Turner, “Backscatter modulation of Impedance Modulated RFID tags”, February 2003
- [81] Govardhan, “Performance Modeling and Design of Backscatter RFID Systems: A Statistical Approach”, July 2006
- [82] Bletsas, Dimitriou, Sahalos, “Improving Backscatter Radio Tag Efficiency”, June 2012
- [83] Inciting, Rao, Lam, “UHF RFID Tag Characterization: Overview and
- [84] Cisco White Paper, “RFID Tag Considerations – RFID Tag Technology”, 2001
- [85] Adair, “Radio Frequency Identification (RFID) Power Budgets for Packaging Applications”, November 2005
- [86] Nikitin, Rao, “Theory and Measurement of Backscattering from RFID Tags”, 2006
- [87] ThingMagic Mercury 5e Data Sheet, 2013

- [88] Aroor, Deavours, “ Evaluation of the State of Passive UHF RFID: An Experimental Approach”, December 2007. [Online]. Available: <http://www.ittc.ku.edu/~deavours/pubs/ieeesystems07.pdf>
- [89] Lum, “Experimental Investigation of the Key Factors that Affect the Programming Efficacy of Passive UHF RFID tags”, 2012
- [90] Skyetek, “Skyemodule m9 Datasheet”, 2013
- [91] Alverson, Schoedinger, Underwood, “Radio Frequency identification printing device”, US Patent 8,482,75, July 9, 2013.
- [92] Powers, Underwood, “Apparatus and method for evaluating RFID programming” US patent 8,107,101, January 31, 2012.
- [93] Barnett, Kallop, Marowski, Neiland, Powers, Ritter, Rowland, Steely, Underwood, “Modular RFID imaging device option”, US Patent 8,313,187, November 20, 2012.

## VITA

Donnie Proffitt, was born in London, Kentucky. He received an Associate of Science degree in Science of Engineering from Eastern Kentucky University in 2000 and a Bachelor of Science degree in Mechanical Engineering from the University of Kentucky in 2002. He received several scholastic and professional honors from his department, Tau Beta Pi and Pi Tau Sigma. He earned a Student Lean Manufacturing certification in 2001. During his college career, he held professional positional at Panasonic Home Appliance of America and currently works at Lexmark International as a design engineer. Profession publications were pending at the time of this thesis publication.