



University of Kentucky
UKnowledge

University of Kentucky Doctoral Dissertations

Graduate School

2000

POST-TRANSCRIPTIONAL REGULATION OF MAMMALIAN HEAT SHOCK FACTORS

Michael L. Goodson
University of Kentucky

[Right click to open a feedback form in a new tab to let us know how this document benefits you.](#)

Recommended Citation

Goodson, Michael L., "POST-TRANSCRIPTIONAL REGULATION OF MAMMALIAN HEAT SHOCK FACTORS" (2000). *University of Kentucky Doctoral Dissertations*. 256.
https://uknowledge.uky.edu/gradschool_diss/256

This Dissertation is brought to you for free and open access by the Graduate School at UKnowledge. It has been accepted for inclusion in University of Kentucky Doctoral Dissertations by an authorized administrator of UKnowledge. For more information, please contact UKnowledge@lsv.uky.edu.

ABSTRACT OF DISSERTATION

Michael L. Goodson

The Graduate School
University of Kentucky

2000

POST-TRANSCRIPTIONAL REGULATION
OF MAMMALIAN HEAT SHOCK FACTORS

ABSTRACT OF DISSERTATION

A dissertation submitted in partial fulfillment of the
Requirements from the degree of Doctor of Philosophy
at the University of Kentucky

By

Michael L. Goodson

Lexington, Kentucky

Co-Director: Dr. Kevin D. Sarge, Associate Professor of Biochemistry

Co-Director: Dr. Salvatore J. Turco, Professor of Biochemistry

Lexington, Kentucky

2000

ABSTRACT OF DISSERTATION

POST-TRANSCRIPTIONAL REGULATION OF MAMMALIAN HEAT SHOCK FACTORS

Heat shock transcription factors (HSFs) function to regulate the expression of heat shock proteins (hsps) or molecular chaperones in the cell. Mammalian cells have two well-characterized HSFs, HSF1 and HSF2. HSF1 functions to regulate the stress-induced expression of hsps. The function of HSF2 appears to be in regulating hsp expression during development and differentiation.

In this work, I describe two distinct HSF1 mRNA isoforms (HSF1- α and HSF1- β) that are generated by alternative splicing of the HSF1 pre-mRNA. The two HSF1 mRNA isoforms result from the inclusion (HSF1- α), or omission (HSF1- β), of a 66 nucleotide exon of the HSF1 gene, which encodes a 22 amino acid sequence. These results show that the levels of the HSF1- α and HSF1- β mRNA isoforms are regulated in a tissue-dependent manner, with testis expressing predominantly the HSF1- β isoform while heart and brain express primarily the HSF1- α isoform.

In addition, I describe two distinct HSF2 mRNA isoforms (HSF2- α and HSF2- β) that are generated by alternative splicing of the HSF2 pre-mRNA. The two HSF2 mRNA isoforms result from the inclusion (HSF2- α), or omission (HSF2- β), of a 54 nucleotide

exon of the HSF2 gene, which encodes a 18 amino acid sequence. These results show that the levels of the HSF2- α and HSF2- β mRNA isoforms are regulated in a tissue-dependent manner, with testis and brain expressing predominantly the HSF2- α isoform while heart, liver, and kidney express primarily the HSF2- β isoform. Furthermore, HSF2 isoform levels are regulated both in a developmental and cell type dependent manner in the testis. In a reporter assay, HSF2- α is a 2.6-fold better transcriptional activator than the HSF2- β isoform.

We have demonstrated also that HSF2, but not HSF1 is a substrate for SUMO-1 and SUMO-2 modification *in vitro*. Consistent with this, we have demonstrated that HSF2 can interact with a portion of Ubc9, the SUMO-1 conjugating enzyme, in a two-hybrid assay. We have also shown that GFP-HSF2 colocalizes with SUMO-1 in discrete nuclear domain structures in 7% of GFP-HSF2 expressing HeLa cells. Finally, we have shown that lysine 82 of HSF2 is the primary site of SUMO-1 modification *in vitro*.

POST-TRANSCRIPTIONAL REGULATION
OF MAMMALIAN HEAT SHOCK FACTORS

By

Michael L. Goodson

Co-Director of Research

Co-Director of Research

Director of Graduate Studies

RULES FOR THE USE OF DISSERTATIONS

Unpublished dissertations submitted for the Doctor's degree and deposited in the University of Kentucky Library are as a rule open for inspection, but are to be used only with due regard to the rights of the authors. Bibliographical references may be noted, but quotations or summaries of parts may be published only with the permission of the author, and with the usual scholarly acknowledgments.

Extensive copying or publication of the dissertation in whole or in part also requires the consent of the Dean of the Graduate School of the University of Kentucky.

A library that borrows this dissertation for use by its patrons is expected to secure the signature of each user.

Name

Date

DISSERTATION

Michael L. Goodson

The Graduate School
University of Kentucky

2000

POST-TRANSCRIPTIONAL REGULATION
OF MAMMALIAN HEAT SHOCK FACTORS

DISSERTATION

A dissertation submitted in partial fulfillment of the
Requirements from the degree of Doctor of Philosophy
at the University of Kentucky

By

Michael L. Goodson

Lexington, Kentucky

Co-Director: Dr. Kevin D. Sarge, Associate Professor of Biochemistry

Co-Director: Dr. Salvatore J. Turco, Professor of Biochemistry

Lexington, Kentucky

2000

Acknowledgments

First, I would like to acknowledge the contribution of Dr. Kevin Sarge, my mentor, by whose efforts, I have learned a great deal about the scientific process. Needless to say (though I still am saying it), this work could not have happened without his support. Secondly, I would like to recognize the support of my dissertation committee: Dr. Sam Turco, Dr. Mark Kindy, Dr. Wendy Katz, and Dr. Brett Spear. Their advice has been instrumental in my work. I would also like to thank my outside examiner Dr. Tae Ji, for his comments on my dissertation during the thesis defense process.

I would also very much like to acknowledge our department's graduate secretary, Carol Fowler. Every biochemistry graduate student reaps the benefits of Carol's tireless efforts to make to graduate process as pleasant as possible. When she retires next month she will be sorely missed.

Also, I would like to acknowledge our collaborators. Dr. Michael Matunis performed all of the SUMO-1 *in vitro* modification assays. In addition, he provided many plasmids, the SUMO-1 antibody, and a great deal of SUMO-1 expertise. Without his help, Chapter 3 of this dissertation would not have been possible. Dr. Joana Desterro and Dr. Ronald Hay provided several SUMO-1 plasmids, including the GST-SUMO-1 expression plasmid. Dr. Yongho In and Dr. Okkyong Park-Sarge provided the Ubc9 yeast two hybrid plasmid and initially discovered the Ubc9/HSF2 interaction. Finally, Dr. Sindy Whiteheart provided expertise with immunofluorescent microscopy, as well as the microscope. Thanks, Wally.

Finally, I would like to thank my family. My parents have always been supportive of my education. I'm still not leaving college, Mom. Most of all, however, I would like to thank God from whom all of life's blessings flow, and to thank my wife Brenda, the greatest of all blessings. She has been both a great scientist and a great friend. To this work she has contributed innumerable ideas as well as editorial comments. She has also always been my solace throughout this process. Brenda, you are my colleague, my friend, my bulwark, my lover, my soul mate. You give my life meaning. I love you, and I dedicate this work to you.

And, because every dissertation should have a little Latin in it. . .

"Probae esti in segetem sunt deteriolem datae fruges, tamen ipsae suaptae enitent."

-- Accius, *Atreus*

Table of Contents

Acknowledgments.....	iii
List of Tables	vii
List of Figures	viii
Chapter 1 <i>Background and Introduction</i>	1
Transcription factors, regulators of eukaryotic RNA synthesis	1
RNA splicing—removing garbage or creating diversity?	4
The cellular stress response.....	12
Spermatogenesis, the process of germ cell maturation.....	18
Chapter 2 <i>Alternative Splicing Isoforms of HSF1 and HSF2</i>	29
Introduction.....	29
Materials and Methods.....	39
Experimental Animals	39
RT-PCR Analysis.....	39
Isolation and Cloning of HSF1 cDNA and Genomic DNA Sequences	41
Western Blot (Immunoblot) and Gel Mobility Shift Analysis.....	42
HSF2 Transfection of NIH 3T3 Cells and Luciferase Assays	42
Results	43
Tissue distribution of HSF1 mRNA isoforms.	43
Tissue distribution of HSF2 mRNA isoforms.	44
Cloning of HSF1 cDNA isoforms.....	45
Cloning of HSF2 cDNA isoforms.....	46
Cloning of the HSF1 genomic DNA from the splice variant region.	46
HSF1- α splicing creates a fifth potential leucine zipper.	47
Cloning of the HSF2 genomic DNA from the splice variant region.	48
Developmental Regulation of HSF2 mRNA Splicing.	49
Increased transcriptional activity of the HSF2- α isoform.	49
Discussion.....	75
HSF1 alternative splicing—implications for differential stress response activation.	75
HSF2 alternative splicing—implications for spermatogenic gene regulation.	76
Chapter 3 <i>SUMO-1 Modification of HSF2</i>	79
Introduction.....	79
Materials and Methods.....	93
Plasmid DNA Construction	93
SUMO-1 Consensus Site Pattern Matching.....	94
Site Directed Mutagenesis of HSF2.....	95
Yeast Transformation and the Two-Hybrid Assay.	95
<i>In vitro</i> SUMO-1 Modification Assay	97
Recombinant Protein Expression.....	97
Recombinant Protein Purification.....	98

Transient Transfection of HeLa Cells	100
Immunofluorescent Microscopy	101
Results	102
Two Hybrid Analysis of the HSF2/Ubc9 interaction	102
<i>In vitro</i> SUMO-1 modification of HSF2	106
Nuclear colocalization of SUMO-1 and GFP-HSF2.	108
Identification of the SUMO-1 modification site in HSF2.	110
Discussion	130
Chapter 4 <i>Discussion and Future Directions</i>	132
The functional difference between HSF1- α and HSF1- β	132
The possibility of stress induced SUMO modification of HSF1.	133
The role of HSF2- α and HSF2- β in spermatogenesis.	134
Other functions of HSF2	134
The regulation of the SUMO-1 modification of HSF2.	135
The 26S proteasome and SUMO modification of HSF2.	136
Appendix	138
Appendix A: List of Abbreviations	138
References	139
Vitae	152

List of Tables

Table 1. Quantification of GFP-HSF2 nuclear domain staining	110
--	------------

List of Figures

Figure 1.1: Schematic representation of the RNA splicing reaction.	7
Figure 1.2: Schematic representation of alternative splicing.	11
Figure 1.3: Schematic diagram of the cellular stress response.	15
Figure 1.4: Schematic diagram of spermatogenesis.	22
Figure 1.5: Diagram of one cycle of spermatogenic stages.	27
Figure 2.1: Human and mouse HSF DNA and protein sequence alignments.....	31
Figure 2.2: RT-PCR analysis of HSF1 mRNA isoforms in mouse tissues.....	52
Figure 2.3: Western blot analysis of HSF2 protein from mouse tissues.....	54
Figure 2.4: RT-PCR analysis of HSF2 mRNA isoforms in mouse tissues.....	56
Figure 2.5: Nucleotide and deduced amino acid sequences of HSF1 mRNA isoform cDNAs.....	58
Figure 2.6: Nucleotide and deduced amino acid sequences of HSF2 mRNA isoform cDNAs.....	60
Figure 2.7: Sequence of HSF1 gene regions corresponding to alternative splice junctions.	62
Figure 2.8: Schematic representation of HSF1 mRNA alternative splicing.....	64
Figure 2.9: Novel leucine zipper motif in HSF1- α	66
Figure 2.10: Sequence of HSF2 gene regions corresponding to alternative splice junctions.....	68
Figure 2.11: Schematic representation of HSF2 mRNA alternative splicing.....	70
Figure 2.12: RT-PCR analysis of HSF2 isoforms during testis development.....	72
Figure 2.13: Reporter gene analysis of HSF2- α and HSF2- β isoforms.....	74
Figure 3.1: Schematic representation of the ubiquitination cycle.....	81
Figure 3.2: Schematic representation of the SUMO-1 modification cycle.....	86
Figure 3.3: Schematic diagram of the yeast two hybrid assay.....	105
Figure 3.4: Two-hybrid analysis of the HSF2/Ubc9 interaction.....	113
Figure 3.5: <i>In vitro</i> SUMO-1 and SUMO-2 modification of HSF2.....	115
Figure 3.6: <i>In vitro</i> SUMO-1 modification analysis of HSF1.....	117
Figure 3.7: Colocalization of GSP-HSF2 and SUMO-1.....	119
Figure 3.8: Unique localization of GFP-HSF2.....	121
Figure 3.9: Purification of recombinant HSF1 and SUMO-1.....	123
Figure 3.10: Preadsorbed control for SUMO-1 Immunofluorescent Staining.....	125
Figure 3.11: Consensus SUMO-1 modification site analysis of HSF2.....	127
Figure 3.12: <i>In vitro</i> modification analysis of HSF2 mutants.....	129

Chapter 1

Background and Introduction

TRANSCRIPTION FACTORS, REGULATORS OF EUKARYOTIC RNA SYNTHESIS

Each cell in a multicellular organism has DNA with exactly the same sequence as every other cell in that organism, yet the cells of that organism are highly diverse both in function and morphology. With only a few small exceptions, such as gene rearrangement in immune cells, germ cells, transposons, and random mutations, this is true for every metazoan. How then does an organism generate this cellular diversity from identical genetic material? The answer to this lies in the pattern of gene expression. Different cells express different genes at different levels. Therefore, an organism must carefully regulate the expression of its genes. One major mechanism for controlling gene expression is by regulating transcription of DNA into RNA (Maniatis et al., 1987).

Eukaryotic genes are transcribed by one of three RNA polymerases. RNA polymerase I transcribes ribosomal RNA. RNA polymerase III transcribes small RNA molecules such as the 5S ribosomal RNA and transfer RNA. RNA polymerase II transcribes RNA from genes that will be translated into protein, called messenger RNA (Chambon, 1975; Geiduschek and Tocchini-Valentini, 1988; Sentenac, 1985; Sollner-Webb and Tower, 1986). In eukaryotes, RNA polymerases are large multi-subunit protein complexes with masses of 500 kDa or more. Unlike in prokaryotes and viruses, the eukaryotic RNA polymerases do not directly recognize DNA sequences. Rather

DNA binding proteins, called transcription factors, bind to specific sequences in the promoter regions of genes and thereby recruit the RNA polymerase complexes (Brown, 1984; Workman and Roeder, 1987).

Promoter regions are transcriptional regulatory sequences of genes that can be divided into two categories proximal promoter elements and distal enhancer elements. The basal promoter elements contain sequences such as GAGA elements, the TATA box, or the initiator (Inr) motif. Basal promoter elements are highly context sensitive and must be located near the transcription start site (Atchison, 1988; Maniatis et al., 1987; McKnight and Kingsbury, 1982). For example, in genes that contain one, the TATA box is always located approximately 30 bp upstream of the start site. In contrast, enhancer elements are often found several kb upstream of the transcription start site. They can also be found several kilobases upstream of the gene, downstream of the gene, or within the transcribed region of the gene. Enhancer regions usually contain binding sites for multiple regulatory proteins and are normally modular. This modular quality means that enhancers can often be moved to different locations within the promoter region of a gene, or within the context of a completely different basal promoter and gene (as in the case of a reporter gene assay) (Atchison, 1988; Emerson et al., 1987; Evans et al., 1988; Jones et al., 1988; Nomiya et al., 1987).

Similarly transcription factors can be divided into two categories: i) general transcription factors, which bind to basal promoter elements in nearly all genes and to the RNA polymerase complex, and ii) transcription enhancers and repressors which bind to enhancer elements. For the purpose of this introduction, I will specifically refer to general transcription factors and will often refer to transcription enhancers and repressors

as transcription factors. All three RNA polymerases have general transcription factors (TFI, TFII, and TFIII) for binding to promoters and regulating transcription of their respective genes. In this introduction, I will limit discussion to RNA polymerase II transcription factors.

General transcription factors bind to the basal promoter region of most genes forming a stable complex on the DNA and recruiting the RNA polymerase. Examples of general transcription factors include TFIIA, TFIIB, TFIID (which includes the TATA binding protein, TBP), TFIIE, and TFIIH and GAGA factors (Burley and Roeder, 1996; Orphanides et al., 1996; Roeder, 1996). These factors are expressed in all tissues, and therefore cannot account for the diverse patterns of gene expression found in the body.

Transcription enhancers and repressors, which bind to sequences in the enhancer region, are much more diverse in composition, function, and expression than the general transcription factors. Heat shock factors (HSFs) are considered transcription enhancers. Transcription enhancers (or repressors) bind to DNA and modulate transcription by several mechanisms. Some function by bending DNA and changing the proximity to other elements (Ogbourne and Antalis, 1998). Others function by interacting with the general transcription factors or the RNA polymerase and modulating the function of these components. Still others interact with other transcription enhancers or repressors to modulate an effect synergistically (Evans, 1988; Schulman et al., 1995). Transcription enhancers and repressors are particularly interesting because they are often functionally regulated (Verrijzer and Tjian, 1996). Regulation of transcription factors may occur by regulation of transcription factor expression, by interaction with a cellular factor or ligand, as in the steroid hormone receptors, or by modification by a receptor or receptor

mediated signal transduction cascade, as in STATs, fos, or jun. To this already complex paradigm of multiple transcription factors, each regulated in its own unique fashion, we can add that most transcription factors bind as multimers (Ap-1, RXR, T3R, VDR). The composition of these multimeric transcription factor complexes often dictates DNA binding specificity and the functional consequence of binding—whether the complex activates or represses transcription (Evans, 1988; Umesono and Evans, 1989; Umesono et al., 1991). Also, many transcription factors interact in a regulated fashion with other cellular factors that can modulate transcriptional activity. Such layers of regulation can create the tremendous diversity of gene expression necessary for a multicellular organism (Chen, 1999).

RNA SPLICING—REMOVING GARBAGE OR CREATING DIVERSITY?

As described previously, eukaryotic genes are transcribed by one of three RNA polymerases. Of these, only RNA polymerase II transcribes genes that will be translated into proteins. The mRNA transcribed from RNA polymerase II is modified at the 5' end by the addition of a unique cap structure—7-methyl-guanosine in a 5' to 5' triphosphate linkage—called the 5' cap (Shatkin, 1987). The 3' end of the RNA is also modified by the addition of a series of non-encoded adenosine residues called the poly-A tail. Only messenger RNA contains a 5' cap and a poly-A tail (Sisodia et al., 1987; Smale and Tjian, 1985).

In addition to 5' capping and poly-A tailing, eukaryotic mRNA, particularly mRNA from metazoans, requires further processing. The genes encoding proteins in

higher eukaryotes contain both coding sequences referred to as exons and intervening sequences referred to as introns. The process of removing the introns in pre-mRNA and joining the exons to form mature mRNA is called RNA splicing (Chambon, 1981; Crick, 1979; Perry, 1981). A large macromolecular complex called the spliceosome, which contains four small nuclear ribonucleoproteins (snRNPs) U1, U2, U5, and U4/U6, usually carries out the splicing reaction (Figure 1.1) (Dreyfuss et al., 1988; Guthrie and Patterson, 1988; Osheim et al., 1985; Samarina et al., 1966; Steitz, 1988).

Figure 1.1: Schematic representation of the RNA splicing reaction.

U1 and U2 snRNPs bind to the 5' donor and branch point adenosine sites within the intron of a pre-mRNA, causing assembly of the spliceosome and bending of the pre-mRNA. Reciprocal nucleophilic attacks by the branch point adenosine and then the 5' donor site result in the joining of the exonic sequences and liberation of the intron as a branched lariat structure. Figure adapted from *Molecular Biology of the Cell* 2nd ed. (Alberts et al., 1989).

The U1 snRNP binds to the 5' donor site at the 5' end of an intron. The U2 snRNP binds to an adenosine residue near the 3' end of the exon called the branchpoint adenosine. The U5 and the U4/U6 snRNPs then assemble around the other two snRNPs to form the spliceosome complex, which holds the pre-mRNA in an appropriate conformation to allow the splicing reactions to occur. The first splicing reaction is a nucleophilic attack on the phosphoester bond of the 5' donor site by the 2' hydroxyl group of the branchpoint adenosine. This reaction leaves a free 3' hydroxyl group on the 5' donor site and creates a branched 5'-3' and 5'-2' phosphodiester bonded structure on the branchpoint adenosine called a lariat structure. The second splicing reaction is a nucleophilic attack on the phosphoester bond of the 3' acceptor site by the 3' hydroxyl group of the 5' donor site. This reaction joins the 5' donor site to the 3' acceptor site in a phosphodiester bond excising the intron as a free lariat structure (Edmonds, 1987; Maniatis and Reed, 1987; Padgett et al., 1986; Reed and Maniatis, 1988; Rio, 1992b). Both the 5' donor site and 3' acceptor sites have consensus sequences that are recognized by the spliceosome and help to confer specificity on the splicing reaction. The consensus sequence for the 5' donor site is 5'-C/A A G * G U A/G A G U.-3' and the 3' acceptor consensus sequence is 5'-(U/C)_n N C/U A G * G/A-3' (where the G U and A G are nearly invariant residues, N is any nucleotide, n is number usually greater than 10, and * represents the boundary between exonic and intronic sequences).

The spliceosome appears to function by binding to the pre-mRNA and holding it in a conformation that favors the splicing reaction. Evidence for this comes from mRNA molecules that can automatically carry out the splicing reactions in the absence of the

spliceosome snRNPs or other protein factors. These mRNA molecules contain regions that are called self-splicing introns. There are two classes of autocatalytic introns referred to as Group I and Group II self-splicing introns, which differ subtly in the splicing reaction mechanism. Group II self-splicing exons carry out chemical reactions identical to those observed for spliceosome mediated RNA splicing. Thus the spliceosome likely evolved from self splicing RNA (Cech, 1986).

The spliceosome is capable of catalyzing the excision of an intron between any 5' donor site and any other 3' acceptor site, even between to separate RNA molecules. Thus, the issue of specificity, as mammalian genes often have a number of introns and exons, is an important question. Failure to appropriately splice the exonic sequences together could easily result in a nonfunctional protein. The consensus sequence addresses the issue of exactness in excision nucleotide selection (Padgett et al., 1986; Rio, 1992b). One likely explanation for the accuracy in overall splice site selection is that splicing occurs simultaneously with transcription. Thus, adjacent splice sites would usually be selected because they would have been synthesized at approximately the same time, thereby removing many of the other choices in possible splice sites. Visualization of the spliceosomes on the elongating mRNA by electron microscopy supports this mechanism (Osheim et al., 1985).

Often in eukaryotes pre-mRNA from a single gene may be spliced in multiple patterns (Rio, 1992a). This alternative splicing can occur from the use of alternative 5' donor sites, alternative 3' acceptor sites, or the inclusion or exclusion of entire exons, called exon skipping (Figure 1.2).

Figure 1.2: Schematic representation of alternative splicing.

Alternative splicing can arise from the use of alternative 5' donor sites, alternative 3' acceptor sites, or the inclusion or omission of entire exons. The gray lines represent alternatively spliced regions of mRNA and the thin bent lines represent joined regions of the RNA molecule.

Figure 1.2: Schematic representation of alternative splicing.

Genomic DNA or pre-mRNA



Processed mRNA

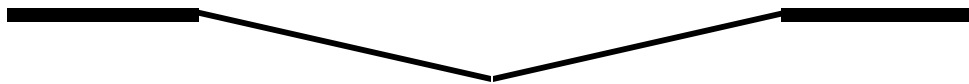

Alternative 5' Donor Site

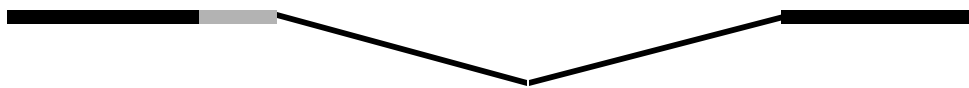

Alternative 3' acceptor Site

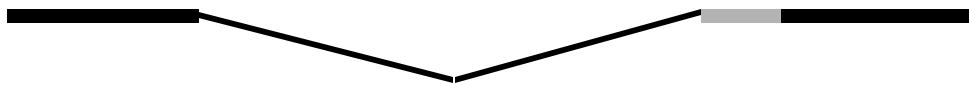

Alternative Exon Inclusion



This alternative splicing often occurs in a tissue dependent or other regulated manner. Alternative RNA splicing presumably functions to provide even greater genetic diversity to an organism. Multiple proteins with differing functions can be made from a single gene.

THE CELLULAR STRESS RESPONSE.

One fundamental requirement of all cells from bacteria to humans is the ability to respond and adapt to stresses. Stress comes in a wide variety of forms from environmental toxins, pathogens, metabolic products, to simple increases in temperature. In order for cells and organisms to remain viable, they must have mechanisms for sensing and responding to these conditions.

One of the common deleterious effects of all of these stresses is protein denaturation. Therefore, organisms express a family of proteins called heat shock proteins (hsps) or molecular chaperones, which bind to malfolded proteins allowing them to refold to their native structure. Hsps accomplish this by repeatedly binding and releasing stretches of hydrophobic amino acids in malfolded proteins (Becker and Craig, 1994; Craig, 1993; Craig et al., 1993; Gilbert, 1994; Hendrick and Hartl, 1993; Hendrick and Hartl, 1995). By binding these hydrophobic stretches, hsps are thought to function to prevent malfolded proteins from becoming aggregating, a situation that requires the degradation of the protein aggregates (Craig et al., 1994).

Eukaryotic cells express a number of different classes of hsps. Certain hsp family members (hsc70 and hsp90) are expressed constitutively in order to assist with *de novo* protein folding (Freeman and Morimoto, 1996). Other family members (BiP and mt hsp70) are expressed in specific organelles such as the endoplasmic reticulum and mitochondria to assist with protein translocation and folding in these organelles (Bhattacharyya et al., 1995; Pfanner et al., 1994; Stuart et al., 1994). The expression of other hsps, such as hsp70, is upregulated in response to cellular stress. These stress-induced hsps were the first identified, and still receive a great deal of study (Schiller et al., 1988).

A family of transcription factors called heat shock factors (HSFs) controls the stress-induced upregulation of hsp gene expression in eukaryotic cells. In metazoan cells, HSFs function by sensing stress, trimerizing, translocating to the nucleus, and binding to DNA to activate transcription. HSFs bind to promoters that contain a heat shock element (HSE), inverted repeats of the DNA sequence NGAAN (Amin et al., 1988; Amin et al., 1994; Morimoto, 1998; Mosser et al., 1988; Perisic et al., 1989). Heat shock protein genes are among the genes that contain HSEs in their promoters (Figure 1.3).

Figure 1.3: Schematic diagram of the cellular stress response.

Stressful conditions such as heat shock, heavy metals, oxidative stress, or ischemia, or conditions such as early embryonic development act on the cell to activate HSF1.

Developmental and differentiation states such as spermatogenesis influence the cell and cause the activation of HSF2. During late embryogenesis, both HSF1 and HSF2 are activated. Activation of HSF results in its trimerization, nuclear localization, acquisition of DNA binding, and activation of transcription. HSF activation results ultimately in the upregulation of hsps, which provides a cytoprotective function through protein chaperoning activity.

Figure 1.3: Schematic diagram of the cellular stress response.

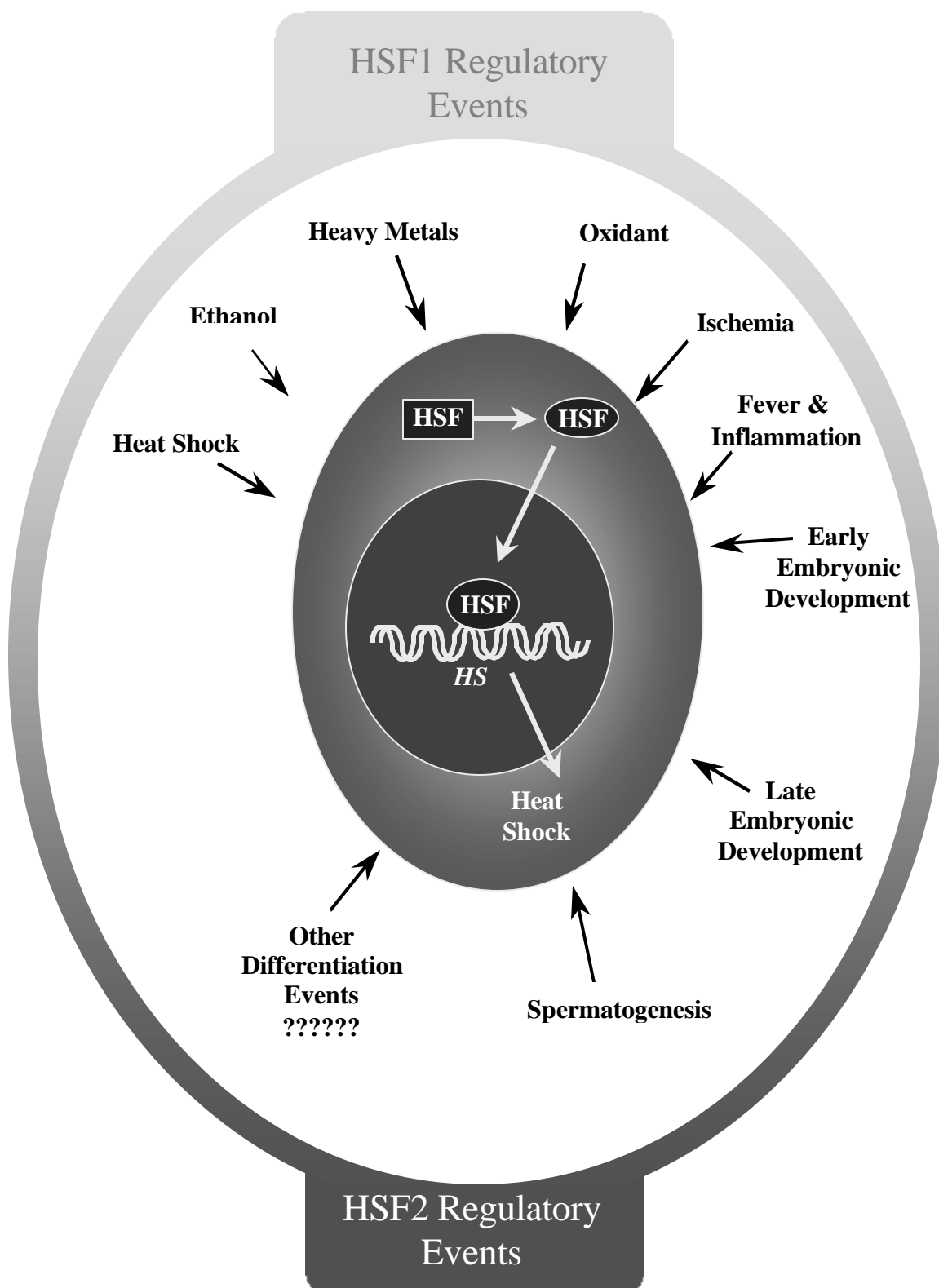

How heat shock factors sense stress is still unclear. One popular hypothesis is that heat shock factors can directly sense denatured proteins in the cell. This model explains how a wide variety of compounds and stresses could activate HSFs. This model also explains the observation that an HSF from the same organism can have different activation temperatures in different tissues or when ectopically expressed in a different organism (Brown, 1995; Voellmy, 1996).

In mammalian cells there are at least four HSF genes with multiple alternative mRNA splicing isoforms arising from at least two of the HSFs (Nakai et al., 1995; Nakai et al., 1997; Rabindran et al., 1991; Sarge et al., 1991; Schuetz et al., 1991). The best characterized of these are HSF1 and HSF2. HSF1 is the HSF that is responsible for sensing stress and activating expression of hsp genes as described previously (Morimoto et al., 1992). HSF2, on the other hand, has traditionally been thought to regulate hsp genes during development and differentiation, although the data for this are not as strong as for the role of HSF1 (Alastalo et al., 1998; Mezger et al., 1994; Murphy et al., 1994; Pirkkala et al., 1999; Sarge et al., 1994; Sistonen et al., 1992). Recently, HSF2 has also been shown to interact with a regulatory subunit of protein phosphatase 2A (PP2A), suggesting that it may also have a role in regulating phosphatase activity in the cell (Hong and Sarge, 1999). So, to date, the role (or roles) for HSF2 in the cell remains unclear.

The cellular function of HSF1 has been well characterized. HSF1 exists as a phosphorylated non-DNA binding monomer in unstressed cells. Upon exposure to stress, HSF1 trimerizes, becomes hyperphosphorylated, translocates to the nucleus, binds to specific DNA elements called HSEs, and activates transcription (Baler et al., 1993; Sarge

et al., 1993; Westwood and Wu, 1993). Many stressful stimuli that activate HSF1 have been characterized. Chemical and environmental stresses such as heavy metals, amino acid analogs, metabolic inhibitors, and elevated temperature all activate HSF1. In addition, certain pathophysiological conditions such as fever, inflammation, ischemia, and oxidative damage also activate HSF1 (Morano and Thiele, 1999; Morimoto et al., 1996).

HSF1 does not require phosphorylation for activity, but phosphorylation does modulate its activity. Phosphorylation in the basal inactive state at Ser 303 and Ser 307 represses transcriptional activity (Chu et al., 1996; Farkas et al., 1998; Kim et al., 1997; Kline and Morimoto, 1997; Knauf et al., 1996; Mivechi and Giaccia, 1995; Shi et al., 1995). Activation of HSF1 produces changes in phosphorylation pattern. The active state phosphorylation functions to increase the transcriptional activity of HSF1 (Cotto et al., 1996; Xia et al., 1998; Xia and Voellmy, 1997). Not all stimuli that activate HSF1 DNA binding also induce hyperphosphorylation (Cullen and Sarge, 1997; Jurivich et al., 1995). Activation by these stimuli is associated with lower levels of transcriptional activity. Sodium salicylate, for example, activates HSF1 DNA binding, but does induce that hyperphosphorylation observed with heat, and appears to actually inhibit HSF1 from activating transcription (Giardina and Lis, 1995; Jurivich et al., 1995; Jurivich et al., 1992).

HSF2 mRNA and protein is expressed in every tissue examined. Regulation of HSF2 occurs during development and differentiation. Both mRNA and protein expression are tightly regulated during spermatogenesis. HSF2 mRNA is expressed at very high levels in pachytene spermatocytes and round spermatids (Alastalo et al., 1998;

Sarge et al., 1994). HSF2 mRNA levels are undetectable in early spermatogenic stages (spermatogonia and leptotene spermatocytes) and in later stages of spermatogenesis (elongated spermatids and mature spermatozoa). Consistent with this, germ cell expressed mRNA only begins to appear twenty-one days postpartum, coincident with onset of spermatogenesis (Sarge et al., 1994).

HSF2 activation appears to be coincident with HSF2 protein level. In tissues where HSF2 is expressed at high levels (brain and testis) HSF2 appears to be active ((Sarge et al., 1994); data not shown). In most situations, HSF2 activity does not appear to be inducible in the same sense as HSF1. The only exception to this is in the immortalized erythroid cell line K562 in which treatment with hemin causes K562 cells to differentiate into erythrocytes and causes HSF2 activation (Pirkkala et al., 1999; Sistonen et al., 1992; Theodorakis et al., 1989). However, K562 cells are the only cells that exhibit HSF2 activation by hemin treatment. Treatment of K562 cells with hemin also causes an increase in HSF2 protein levels. Recently, HSF2 has also been shown to be activated by drugs that block 26S proteasome function, causing an increase in HSF2 protein levels. These observations are consistent with the model that HSF2 activity is regulated by protein level (Mathew et al., 1998).

SPERMATOGENESIS, THE PROCESS OF GERM CELL MATURATION

Spermatogenesis is the process of formation for male gametes or germ cells. The entire process of spermatogenesis occurs in the testis. The testis is organized into two compartments, the interstitium and the seminiferous tubules (Russell et al., 1990). The

interstitial compartment contains blood vessels, testicular macrophages, lymphatic ducts, and Leydig cells. The purpose of the interstitial compartment is to provide the circulatory architecture required to provide nutrients and other required factors to the developing germ cells in the seminiferous tubules (Russell et al., 1990).

The seminiferous tubules are convoluted tubules that contain the developing germ cells. Each tubule is connected at each end to the effluent duct, the rete testis, by a short straight tubule (Clermont and Huckins, 1961). While each seminiferous tubule is highly convoluted, the tubule runs primarily longitudinally through the testis, allowing for cross sectioning of the tubules through the testis. The actual tubule is comprised of collagen layers bracketing two basement membranes which are separated by myoid cells. Within the tubule, there are germ cells and nurse cells called Sertoli cells (Clermont, 1958; Dym and Fawcett, 1970). As the developing sperm cells do not come into contact with the lymph or blood system, they must receive all of the nutrients and growth factors they need for development from the Sertoli cells (Clermont, 1958; Dym and Fawcett, 1970).

Spermatogenesis, or the process of maturation of spermatozoa from proliferative progenitor cells, can be divided into three overall phases. The proliferative phase, or spermatogonia, the meiotic phase, or spermatocytes, and the differentiation phase, or spermatids. Mammals are required to produce millions of mature sperm cells every day. This necessitates continuous production of large numbers of germ cells, which is the role of spermatogonia (Russell et al., 1990). Spermatogonia can be further subdivided into three classes, stem cells, proliferative cells, and differentiating cells. The stem cell spermatogonia are referred to as type $A_{isolated}$ (A_{is}) spermatogonia, and are the most primitive of the germ cell types (Huckins, 1971). A_{is} are the most insult resistant germ

cell type due to their relatively infrequent division. For this reason, A_{is} spermatogonia often survive when other germ cells are killed off, leading to temporary infertility, and why complete loss of A_{is} spermatogonia would result in irreversible infertility (Dym and Clermont, 1970; Huckins and Oakberg, 1978). A_{is} divide to regenerate A_{is} cells and to form A_{paired} (A_{pr}) spermatogonia, the first of the two proliferative spermatogonial cell types (Figure 1.4).

Figure 1.4: Schematic diagram of spermatogenesis.

Germ cells develop from a single self-regenerating stem cell (a type A_{isolated} spermatogonia) into mature spermatozoa through a series of mitotic and meiotic (M-I and M-II) divisions and differentiation steps. Spermatogonia are the proliferative germ cells, spermatocytes are the meiotic germ cells, and spermatids are the differentiating germ cells. Branched arrows represent a cell division. Straight arrows represent a differentiation step. See text for a description of cell type abbreviations. Figure adapted from *Histological and Histopathological Evaluation of the Testis* (Russell et al., 1990)

Figure 1.4: Schematic diagram of spermatogenesis.

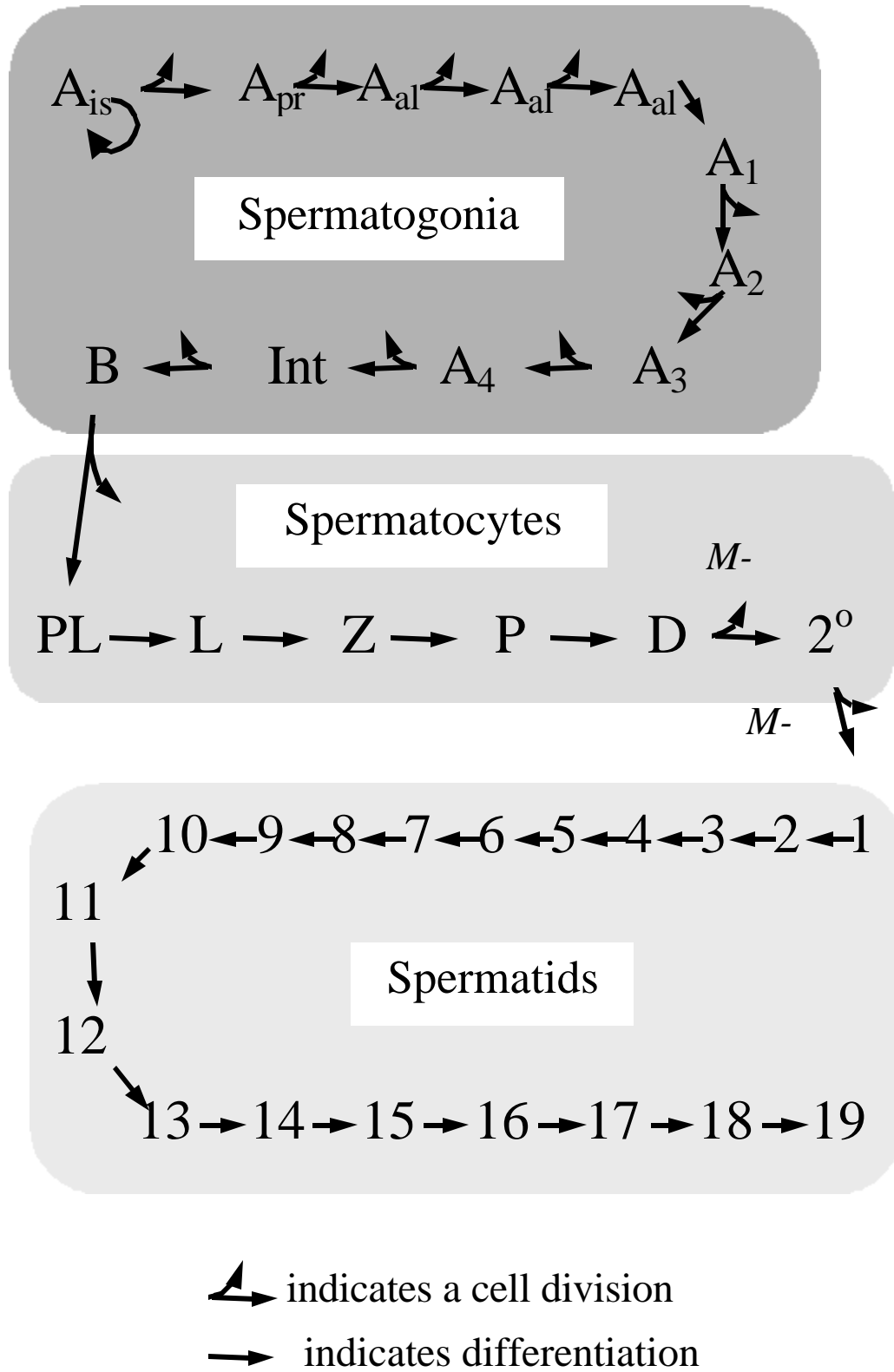

A_{pr} divide to form $A_{aligned}$ (A_{al}) spermatogonia. The terms paired and aligned refer to their connections to other spermatogonia through intercellular bridges, open cytoplasmic junctions that connect germ cells and are thought to promote synchronous growth of spermatogonia and other germ cell types (Weber and Russell, 1987). A_{al} divide to form more A_{al} cells (Huckins, 1978a; Huckins, 1978b; Roosen-Runge, 1973). Though the signal is not known, when a sufficient number of A_{al} spermatogonia are generated, they differentiate in mass to the first differentiating type of spermatogonia, A_1 . A_1 spermatogonia then divide three more times, forming A_2 , A_3 and A_4 spermatogonia. A_4 spermatogonia divide to form intermediate (Int) spermatogonia, which then divide to form type B spermatogonia (Huckins and Oakberg, 1978). A, Int, and B spermatogonia differ morphologically by the amount of chromatin, or packaged chromosomal DNA, located near the inner face of the nuclear envelope. Type A have almost no chromatin at the periphery of the nucleus, while Type Int and B spermatogonia have progressively more. Spermatogonia reside at the basal membrane of the seminiferous tubule. They have a flat surface that is in contact with the wall of the tubule and a rounded surface that is in contact with the Sertoli cell (Russell, 1977).

Type B spermatogonia divide and differentiate into preleptotene (PL) spermatocytes, the first of the primary spermatocyte lineages. This is the first of the meiotic cell types. PL are the last germ cell type to undergo S-phase (DNA replication) (Moses, 1969; Russell and Frank, 1978). PL differentiate to form leptotene (L) spermatocytes. L can be distinguished from PL mostly on the basis of morphology. L spermatocytes begin to round up, detach from the wall, and migrate away from the basal lamina of the seminiferous tubule. L spermatocytes lose their peripheral chromatin and

begin forming chromosomal threads, but chromosomes are not yet paired (Russell, 1977; Russell, 1978). L differentiate into zygotene (Z) spermatocytes as their chromosomes begin to pair (Moses, 1969). When homologous chromosomes have paired, Z spermatocytes have differentiated into pachytene (P) spermatocytes. Germ cells remain as P spermatocytes for a very long time. The prophase of meiosis lasts approximately three weeks, and of that time, germ cells are P spermatocytes for 1.5 –2 weeks. During this phase genetic recombination, or crossing over, occurs. During the last half of the P spermatocyte development, cells become highly synthetic, producing the large amount of cytosolic and nuclear components required for meiosis, and increase greatly in volume (Monesi, 1965; Russell and Frank, 1978). As P spermatocytes differentiate to form diplotene (D) spermatocytes, the chromosomes have separated except at regions called chiasmata. While D spermatocytes, the cells undergo the metaphase, anaphase, and telophase of the first meiotic division (MI) (Russell and Frank, 1978). Once the cells have divided, they are referred to as secondary (2°) spermatocytes. The second meiotic division (MII) follows rapidly to form spermatids, and the meiotic phase of spermatogenesis is completed (Russell and Frank, 1978).

The process of differentiation from the immature postmeiotic germ cells to mature spermatozoa is referred to as spermiogenesis and occurs through approximately nineteen morphologically distinct phases (Russell et al., 1990). During spermiogenesis the round spermatids produced from meiosis begin to elongate with the formation of a flagellum. The elongated spermatids then compact their chromosomal DNA and reduce their size by 75% by eliminating water from the cytosol and nucleus and by eliminating cytosol through tubular complexes. Finally the sperm cell reduces its volume by releasing a

residual body when the mature sperm cell is released from the Sertoli cell into the lumen of the seminiferous tubule and is excreted (Russell et al., 1990).

The process of spermatogenesis is highly synchronized and proceeds cyclically through the seminiferous tubule. When tubules are cross-sectioned only certain types of germ cells are found together in a given region of the seminiferous tubule. In mice, the spermatogenic process can therefore be divided into 12 stages based on which cell types are found together in sections of the seminiferous tubule (Figure 1.5) (Leblond and Clermont, 1952; Oakberg, 1956).

Figure 1.5: Diagram of one cycle of spermatogenic stages.

Spermatogenic development is highly synchronized with only certain types of germ cells found together in the seminiferous tubule (called stages). The stages are also ordered with respect to each other within the tubes. Spermatogenesis proceeds through the seminiferous tubule like a wave in a temporally cyclic fashion. Figure adapted from *Histological and Histopathological Evaluation of the Testis* (Russell et al., 1990).

Figure 1.5: Diagram of one cycle of spermatogenic stages.

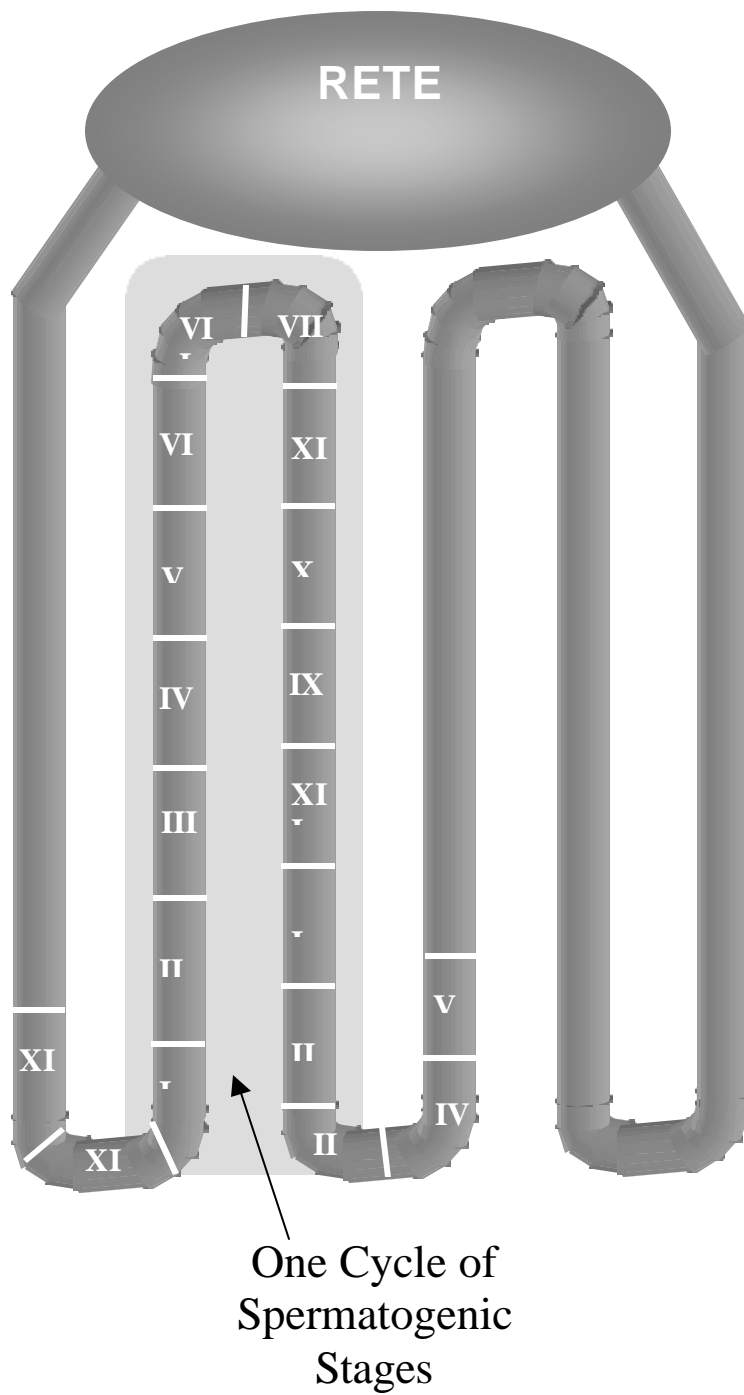

For example, in stage V, only type B spermatogonia, pachytene spermatocytes, Type 5 round spermatids and type 15 elongated spermatocytes are found. In contrast, at stage X, only leptotene and pachytene spermatocytes and type 10 early elongating spermatids are found. One never finds, for example, zygotene spermatocytes and round spermatids together in the same region of a seminiferous tubule (Russell et al., 1990).

Chapter 2

Alternative Splicing Isoforms of HSF1 and HSF2

INTRODUCTION

As described previously, heat shock transcription factors (HSFs) function to regulate the expression of heat shock proteins (hsps) or molecular chaperones in the cell (Craig et al., 1993; Hendrick and Hartl, 1995; Morimoto et al., 1996). Mammalian cells have two well-characterized HSFs, HSF1 and HSF2 (Clos et al., 1990; Rabindran et al., 1991; Sarge et al., 1991; Schuetz et al., 1991). HSF1 is ubiquitously expressed in all cell types examined and functions to regulate the stress-induced expression of hsps. HSF2 is also ubiquitously expressed in cells, though levels vary widely among cell types. The function of HSF2 appears to be in regulating hsp expression during development and differentiation (Alastalo et al., 1998; Mezger et al., 1994; Murphy et al., 1994; Pirkkala et al., 1999; Sarge et al., 1994; Sistonen et al., 1992). Our lab has previously shown that HSF2 mRNA expression is subject to developmental, spermatogenic stage-specific, and cell-type specific regulation in the testis (Sarge et al., 1994). The highest levels of HSF2 are found in pachytene spermatocytes and round spermatids. The DNA binding activity of HSF2 is also regulated in the testis. In most cell types, HSF2 is found in a non-DNA binding form. Testis expressed HSF2, alternatively, is found in a constitutively DNA binding state (Sarge et al., 1994). Furthermore, the DNA binding form of HSF2 found in the testis is capable of binding to promoter sequences from the hsp70.2 gene, a testis-

specific hsp70 family member. This indicates that one function of HSF2 is to regulate hsp gene expression during spermatogenesis (Sarge et al., 1994).

Previous results have suggested the existence of two distinct protein isoforms of both HSF1 and HSF2 in mammalian cell (Sarge et al., 1993). In addition, sequence comparison between the mouse and human homologues of HSF1 and HSF2 suggests that these isoforms likely arise from alternative mRNA splicing (Figure 2.1). In order to establish the mechanism by which these HSF protein isoforms arise, and to explore their biological significance, we have characterized the expression of these HSF1 and HSF2 isoforms in cells of different mouse tissues.

Figure 2.1: Human and mouse HSF DNA and protein sequence alignments.

(A) DNA sequence alignment between the human HSF1 (hHSF1) and mouse HSF1(β) (mHSF1) homologues. The potential alternative mRNA processing region has been bolded.

(B) Predicted protein sequence alignment between the human HSF1 (hHSF1) and mouse HSF1(β) (mHSF1) homologues. The potential alternative mRNA processing region has been bolded.

(C) DNA sequence alignment between the human HSF2 (hHSF2) and mouse HSF2(β) (mHSF2) homologues. The potential alternative mRNA processing region has been bolded.

(D) Predicted protein sequence alignment between the human HSF2 (hHSF2) and mouse HSF2(β) (mHSF2) homologues. The potential alternative mRNA processing region has been bolded.

Figure 2.1 (A) Alignment of the DNA sequences of the human and mouse HSF1 open reading frames.

hHSF1	ATGGATCTGC	CCGTGGGCCC	CGGCGCGGCG	GGGCCAGCA	ACGTCCCGGC
mHSF1	ATGGATCTGG	CCGTGGGCCC	CGGTGCAGCG	GGGCCAGCA	ACGTCCCGGC
hHSF1	CTTCCTGACC	AAGCTGTGGA	CCCTCGTGAG	CGACCCGGAC	ACCGACGCGC
mHSF1	CTTCCTAACC	AAGCTGTGGA	CCCTCGTGAG	CGACCCGGAC	ACAGACGCGC
hHSF1	TCATCTGCTG	GAGCCCAGAGC	GGGAACAGCT	TCCACGTGTT	CGACCAGGGC
mHSF1	TCATCTGCTG	GAGCCCAGAGT	GGGAACAGCT	TCCACGTGTT	TGACCAGGGC
hHSF1	CAGTTTGCCA	AGGAGGTGCT	GCCCAAGTAC	TTCAAGCACA	ACAACATGGC
mHSF1	CAGTTTGCCA	AGGAGGTGCT	GCCCAAGTAC	TTCAAGCACA	ACAACATGGC
hHSF1	CAGCTTCGTG	CGGCAGCTCA	ACATGTATGG	CTTCCGAAA	GTGGTCCACA
mHSF1	TAGCTTCGTG	CGGCAGCTCA	ACATGTATGG	CTTCCGAAA	GTAGTCCACA
hHSF1	TCGAGCAGGG	CGGCCTGGTC	AAGCCAGAGA	GAGACGACAC	GGAGTTCCAG
mHSF1	TTGAGCAGGG	TGGCCTGGTC	AAGCCTGAGA	GAGATGACAC	CGAGTTCCAG
hHSF1	CACCCATGCT	TCCTGCGTGG	CCAGGAGCAG	CTCCTTGAGA	ACATCAAGAG
mHSF1	CATCCTTGTT	TCTTGCGTGG	ACAGGAACAG	CTCCTTGAGA	ACATCAAGAG
hHSF1	GAAAGTGACC	AGTGTGTCCA	CCCTGAAGAG	TGAAGACATA	AAGATCCGCC
mHSF1	GAAAGTGACC	AGCGTGTCCA	CCCTGAAGAG	TGAGGACATA	AAAATACGCC
hHSF1	AGGACAGCGT	CACCAAGCTG	CTGACGGACG	TGCAGCTGAT	GAAGGGGAAG
mHSF1	AGGACAGTGT	CACCCGGCTG	TTGACAGATG	TGCAGCTGAT	GAAGGGGAAA
hHSF1	CAGGAGTGCA	TGGACTCCAA	GCTCCTGGCC	ATGAAGCATG	AGAATGAGGC
mHSF1	CAGGAGTGTA	TGGACTCCAA	GCTCCTGGCC	ATGAAGCACG	AGAACGAGGC
hHSF1	TCTGTGGCGG	GAGGTGGCCA	GCCTTCGGCA	GAAGCATGCC	CAGCAACAGA
mHSF1	CCTGTGGCGG	GAGGTGGCCA	GCCTTCGGCA	GAAGCATGCC	CAGCAGCAA
hHSF1	AAGTCGTCAA	CAAGCTCATT	CAGTTCCTGA	TCTCACTGGT	GCAGTCAAAC
mHSF1	AAGTTGTCAA	CAAGCTCATT	CAGTTCCTGA	TCTCACTGGT	GCAGTCGAAC
hHSF1	CGGATCCTGG	GGGTGAAGAG	AAAGATCCCC	CTGATGCTGA	ACGACAGTGG
mHSF1	CGGATCCTGG	GGGTGAAGAG	AAAGATCCCT	CTGATGTTGA	GTGACAGCAA
hHSF1	CTCAGCACAT	TCCATGCCCA	AGTATAGCCG	GCAGTTCTCC	CTGGAGCACG
mHSF1	CTCAGCACAC	TCTGTGCCCA	AGTATGGTCG	ACAGTACTCC	CTGGAGCATG
hHSF1	TCCACGGCTC	GGGCCCCTAC	TCGGCCCCCT	CCCCAGCCTA	CAGCAGCTCC
mHSF1	TCCATGGTCC	TGGCCCATA	TCAGCTCCAT	CTCCAGCCTA	CAGCAGCTCT
hHSF1	AGCCTCTACG	CCCCTGATGC	TGTGGCCAGC	TCTGGACCCA	TCATCTCCGA
mHSF1	AGCCTTTACT	CCTCTGATGC	TGTCACCAGC	TCTGGACCCA	TAATCTCCGA
hHSF1	CATCACCGAG	CTGGCTCCTG	CCAGCCCCAT	GGCCTCCCC	GGCGGGAGCA
mHSF1	TATCACTGAG	CTGGCTCCCA	CCAGCCCTTT	GGCCTCCCCA	GGCAGGAGCA
hHSF1	TAGACGAGAG	GCCCCTATCC	AGCAGCCCC	TGGTGCGTGT	CAAGGAGGAG

mHSF1	TAGATGAGAG	GCCTCTGTCC	AGCAGCACTC	TGGTCCGTGT	CAAGCAAGAG
hHSF1	CCCCCAGCC	CGCCTCAGAG	CCCCCGGGTA	GAGGAGGCGA	GTCCCCGGCG
mHSF1	CCCCCAGCC	CACCTCACAG	CCCTCGGGTA	CTGGAGGCGA	GCCCTGGGCG
hHSF1	CCCATCTTCC	GTGGACACCC	TCTTGTCCCC	GACCGCCCTC	ATTGACTCCA
mHSF1	CCCATCCTCC	ATGGATACCC	CTTTGTCCCC	AACTGCCTTC	ATTGACTCCA
hHSF1	TCCTGCGGGA	GAGTGAACCT	GCCCCCGC--	-CTCCGTAC	AGCCCTCACG
mHSF1	TCCTTCGAGA	GAGCGAGCCT	ACCCCTGCTG	CCTCAAACAC	AGCCCTATG
hHSF1	GACGCCAGGG	GCCACACGGA	CACCGAGGGC	CGGCCTCCCT	CCCCCCC GCC
mHSF1	GACAC-----	---AACCGGA	GCCCAAG---	----CCCCG	CACTCCCGAC
hHSF1	CACCTCCACC	CCTGAAAAGT	GCCTCAGCGT	AGCCTGCCTG	GACAAGAATG
mHSF1	CCCCTCCACC	CCTGAGAAGT	GCCTCAGCGT	AGCCTGCCTA	GACAAGAACG
hHSF1	AGCTCAGTGA	CCACTTGGAT	GCTATGGACT	CCAACCTGGA	TAACCTGCAG
mHSF1	AGCTAAGTGA	TCACCTGGAT	GCCATGGACT	CCAACCTGGA	CAACCTGCAG
hHSF1	ACCATGCTGA	GCAGCCACGG	CTTCAGCGTG	GACACCAGTG	CCCTGCTGGA
mHSF1	ACCATGCTGA	CAAGCCACGG	CTTCAGTGTG	GACACCAGTG	CCCTGCTGGA
hHSF1	CCTGTT CAGC	CCCTCGGTGA	CCGTGCCCGA	CATGAGCCTG	CCTGACCTTG
mHSF1	C-----	-----	-----	-----	-----
hHSF1	ACAGCAGCCT	GGCCAGTATC	CAAGAGCTCC	TGTCTCCCCA	GGAGCCCCCC
mHSF1	-----	-----ATT	CAGGAGCTTC	TGTCTCCACA	AGAGCCTCCC
hHSF1	AGGCCTCCCG	AGGCAGAGAA	CAGCAGCCCC	GATTCAGGGA	AGCAGCTGGT
mHSF1	AGGCCTATTG	AGGCAGAGAA	CAGTAACCCC	GACTCAGGAA	AGCAGCTGGT
hHSF1	GCACTACACA	GCGCAGCCGC	TGTTCTTGCT	GGACCCCGGC	TCCGTGGACA
mHSF1	GCACTACACG	GCTCAGCCTC	TGTTCTTGCT	GGATCCTGAT	GCTGTGGACA
hHSF1	CCGGGAGCAA	CGACCTGCCG	GTGCTGTTTG	AGCTGGGAGA	GGGCTCCTAC
mHSF1	CAGGGAGCAG	TGAGCTGCCT	GTGCTCTTTG	AGCTGGGGGA	GAGCTCCTAC
hHSF1	TTCTCCGAAG	GGGACGGCTT	CGCCGAGGAC	CCCACCATCT	CCCTGCTGAC
mHSF1	TTCTCTGAGG	GGGATGACTA	CACGGATGAT	CCCACCATCT	CTCTTCTGAC
hHSF1	AGGCTCGGAG	CCTCCCAAAG	CCAAGGACCC	CACTGTCTCC	TAG
mHSF1	AGGCACTGAA	CCCATAAAG	CCAAGGACCC	CACTGTCTCC	TAG

Figure 2.1 (B) Alignment of the protein sequences of the human and mouse HSF1.

```

mHSF1 MDLAVGPGAA GPSNVPAFLT KLWTLVSDPD TDALICWSPS GNSFHVFDQG
hHSF1 MDLPVGPAA GPSNVPAFLT KLWTLVSDPD TDALICWSPS GNSFHVFDQG

mHSF1 QFAKEVLPKY FKHNMMASV RQLNMYGFRK VVHIEQGGLV KPERDDTEFQ
hHSF1 QFAKEVLPKY FKHNMMASV RQLNMYGFRK VVHIEQGGLV KPERDDTEFQ

mHSF1 HPCFLRGQEQ LLENIKRKVT SVSTLKSEDI KIRQDSVTRL LTDVQLMKGK
hHSF1 HPCFLRGQEQ LLENIKRKVT SVSTLKSEDI KIRQDSVTKL LTDVQLMKGK

mHSF1 QECMDSKLLA MKHENEALWR EVASLRQKHA QQQKVVNKLI QFLISLVQSN
hHSF1 QECMDSKLLA MKHENEALWR EVASLRQKHA QQQKVVNKLI QFLISLVQSN

mHSF1 RILGVKRRKIP LMLSDSNSAH SVPKYGRQYS LEHVHGPGPY SAPSPAYSSS
hHSF1 RILGVKRRKIP LMLNDSGSAH SMPKYSRQFS LEHVHGSGPY SAPSPAYSSS

mHSF1 SLYSSDAVTS SGPIISDITE LAPTSPLASP GRSIDERPLS SSTLVRVKQE
hHSF1 SLYAPDAVAS SGPIISDITE LAPASPMASP GGSIDERPLS SSPLVRVKEE

mHSF1 PPSPPHSPRV LEASPGRPSS MDTPLSPTAF IDSILRESEP TPAASNTAPM
hHSF1 PPSPPQSPRV EEASPGRPSS VDTLLSPTAL IDSILRESEP APA-SVTALT

mHSF1 DTTG-----A QAPALPTPST PEKCLSVACL DKNELSDHLD AMDSNLDNLQ
hHSF1 DARGHTDTEG RPPSPPTST PEKCLSVACL DKNELSDHLD AMDSNLDNLQ

mHSF1 TMLTSHGFSV DTSALLD--- -----I QELLSPQEPP
hHSF1 TMLSSHGFSV DTSALLDLFS PSVTVPDMSL PDLSSLASI QELLSPQEPP

mHSF1 RPIEAENSNP DSGKQLVHYT AQPLFLLDPD AVDTGSSELP VLFELGESSY
hHSF1 RPPEAENSSP DSGKQLVHYT AQPLFLLDPG SVDTGSNDLP VLFELGEGSY

mHSF1 FSEGDDYTDD PTISLLTGTE PHKAKDPTVS
hHSF1 FSEG DGFAED PTISLLTGSE PPKAKDPTVS

```

Figure 2.1 (C) Alignment of the DNA sequences of the human and mouse HSF2 open reading frames.

hHSF2	ATGAAGCAGA	GTTCGAACGT	GCCGGCTTTC	CTCAGCAAGC	TGTGGACGCT
mHSF2	ATGAAGCAGA	GTTCCAACGT	GCCGGCTTTC	CTCAGCAAGC	TGTGGACGCT
hHSF2	TGTGGAGGAA	ACCCACACTA	ACGAGTTCAT	CACCTGGAGC	CAGAATGGCC
mHSF2	TGTGGAGGAA	ACCCACACCA	ACGAGTTCAT	CACCTGGAGT	CAGAATGGAC
hHSF2	AAAGTTTTCT	GGTCTTGGAT	GAGCAACGAT	TTGCAAAAGA	AATTCTTCCC
mHSF2	AAAGTTTTCT	GGTCTTGGAT	GAGCAAAGAT	TTGCAAAGGA	AATTCTTCTC
hHSF2	AAATATTTCA	AGCACAAATA	TATGGCAAGC	TTTGTGAGGC	AACTGAATAT
mHSF2	AAGTACTTCA	AACACAATAA	CATGGCGAGC	TTTGTGAGAC	AACTAAATAT
hHSF2	GTATGGTTTC	CGTAAAGTAG	TACATATCGA	CTCTGGAATT	GTAAAGCAAG
mHSF2	GTATGGCTTC	CGAAAAGTAG	TGCATATCGA	ATCTGGAATT	ATCAAACAGG
hHSF2	AAAGAGATGG	TCCTGTAGAA	TTTCAGCATC	CTTACTTCAA	ACAAGGACAG
mHSF2	AAAGAGATGG	CCCTGTTGAA	TTTCAGCATC	CTTATTTCAA	GCAAGGCCAG
hHSF2	GATGACTTGT	TGGAGAACAT	TAAAAGGAAG	GTTTCATCTT	CAAAACCAGA
mHSF2	GATGACCTGT	TGGAGAACAT	TAAAAGGAAG	GTTTCATCTT	CAAAACCAGA
hHSF2	AGAAAATAAA	ATTCGTCAGG	AAGATTTAAC	AAAAATTATA	AGTAGTGCTC
mHSF2	GGAAAATAAA	ATTCGTCAGG	AAGATTTAAC	AAAAATTATT	AGTAGTGCTC
hHSF2	AGAAGGTTCA	GATAAAACAG	GAAACTATTG	AGTCCAGGCT	TTCTGAATTA
mHSF2	AGAAGGTTCA	AATAAAACAA	GAAACTATTG	AGTCCAGGCT	TTCAGAATTA
hHSF2	AAAAGTGAGA	ATGAGTCCCT	TTGGAAGGAG	GTGTCAGAAT	TACGAGCAAA
mHSF2	AAAAGTGAGA	ATGAATCCCT	TTGGAAGGAG	GTGTCAGAAC	TAAGAGCAAA
hHSF2	GCATGCACAA	CAGCAACAAG	TTATTCGAAA	GATTGTCCAG	TTTATTGTTA
mHSF2	GCATGCCCAG	CAGCAACAAG	TTATTCGGAA	GATTGTCCAG	TTTATTGTTA
hHSF2	CATTGGTTCA	AAATAACCAA	CTTGTGAGTT	TAAAACGTAA	AAGGCCTCTA
mHSF2	CATTGGTTCA	GAATAATCAA	CTTGTGAGTT	TAAAACGTAA	AAGGCCTCTA
hHSF2	CTTCTAAACA	CTAATGGAGC	CCAAAAGAAG	AACCTGTTTC	AGCACATAGT
mHSF2	CTTCTAAACA	CAAATGGAGC	CCAAAAGAAG	AATCTATATC	AGCACATAGT
hHSF2	CAAAGAACCA	ACTGATAATC	ATCATCATAA	AGTTCCACAC	AGTAGGACTG
mHSF2	CAAAGAACCA	ACTGATAATC	ACCATCATAA	AGTTCCACAC	AGCAGGACTG
hHSF2	AAGGTTTAAA	GCCAAGGGAG	AGGATTTTTCAG	ATGACATCAT	TATTTATGAT
mHSF2	AAGGTTTAAA	GTCAAGAGAA	CGGATTTTTCAG	ATGACATAAT	TATTTATGAT
hHSF2	GTTACTGATG	ATAATGCAGA	TGAAGAAAAT	ATCCCAGTTA	TTCCAGAAAC
mHSF2	GTTACTGACG	ATAATGTGGA	TGAAGAAAAT	ATTCCAGTTA	TTCCAGAAAC
hHSF2	TAATGAGGAT	GTTATATCTG	ATCCCTCCAA	CTGTAGCCAG	TACCCTGATA
mHSF2	AAATGAGGAT	GTTGTAGTGG	ATTCTCTCCAA	C-----CAG	TATCCTGACA
hHSF2	TTGTCATCGT	TGAAGATGAC	AATGAAGATG	AGTATGCACC	TGTCATTCAG

mHSF2	TTGTCATTGT	TGAAGATGAC	AACGAGGATG	AGTATGCTCC	TGTCATTTCAG
hHSF2	AGTGGAGAGC	AGAATGAACC	AGCCAGAGAA	TCCCTAAGTT	CAGGCAGTGA
mHSF2	AGTGGAGAGC	AGAGTGAACC	AGCCAGAGAA	CCCTTACGTG	TGGGGAGTGC
hHSF2	TGGCAGCAGC	---CCTCTCA	TGTCTAGTGC	TGTCCAGCTA	AATGGCTCAT
mHSF2	TGGCAGCAGC	AGCCCTCTCA	TGTCTAGTGC	TGTCCAGCTA	AACGGCTCCT
hHSF2	CCAGTCTGAC	CTCAGAAGAT	CCAGTGACCA	TGATGGATTG	CATTTTGAAT
mHSF2	CCAGTCTGAC	CTCAGAAGAC	CCTGTGACCA	TGATGGACTC	CATTCTGAAT
hHSF2	GATAACATCA	ATCTTTTGGG	AAAGGTTGAG	CTGTTGGATT	ATCTTGACAG
mHSF2	GACAACATTA	ACCTGTTAGG	AAAGGTTGAG	CTGTTGGATT	ACCTTGACAG
hHSF2	TATTGACTGC	AGTTTLAGAGG	ACTTCCAGGC	CATGCTATCA	GGAAGACAAT
mHSF2	TATTGATTGC	AGTTTLAGAGG	ACTTCCAAGC	TATGCTCTCA	GGAAGACAGT
hHSF2	TTAGCATAGA	CCCAGATCTC	CTGGTTGATC	TTTTCACTAG	TTCTGTGCAG
mHSF2	TTAGCATAGA	CCCAGATCTT	CTGGTTGAT-	-----	-----
hHSF2	ATGAATCCCA	CAGATTACAT	CAATAATACA	AAATCTGAGA	ATAAAGGATT
mHSF2	-----	-----	-----	---TCTGAGA	ATAAGGGACT
hHSF2	AGAAACTACC	AAGAACAATG	TAGTTCAGCC	AGTTTCGGAA	GAGGGAAGAA
mHSF2	AGAAGCTACC	AAGAGCAGTG	TTGTTCAACA	TGTGTCAGAA	GAGGGAAGAA
hHSF2	AATCTAAATC	CAAACCAGAT	AAGCAGCTTA	TCCAGTATAC	CGCCTTTCCA
mHSF2	AATCTAAATC	CAAGCCAGAC	AAACAACCTA	TCCAGTATAC	TGCCTTTCCA
hHSF2	CTTCTTGCAT	TCCTCGATGG	GAACCCTGCT	TCTTCTGTTG	AACAGGCGAG
mHSF2	CTTCTTGCAT	TCCTGGATGG	GAACTCTGCA	TCTGCTATTG	AACAGGGGAG
hHSF2	TACAACAGCA	TCATCAGAAG	TTTTGTCCTC	TGTAGATAAA	CCCATAGAAG
mHSF2	TACAACAGCA	TCGTAGAAG	TTGTGCCTTC	TGTAGATAAA	CCCATAGAAG
hHSF2	TTGATGAGCT	TCTGGATAGC	AGCCTAGACC	CAGAACCAAC	CCAAAGTAAG
mHSF2	TCGATGAGCT	CCTGGATAGC	AGCCTGGATC	CAGAACCGAC	CCAGAGTAAG
hHSF2	CTTGTTCCGCC	TGGAGCCATT	GAAGCTAGCT	GAAGCTAGTG	AAGCTACACT
mHSF2	CTTGTTCCGCC	TGGAACCATT	GAAGCTAGCG	GAAGCTAGTG	AAGCCACACT
hHSF2	GTTTTATTTA	TGTGAACTTG	CTCCTGCACC	TCTGGATAGT	GATATGCCAC
mHSF2	CTTCTATTTA	TGTGAACTTG	CTCCTGCACC	TCTGGATAGT	GATATGCCCG
hHSF2	TTTTAGATAG	CTAA			
mHSF2	TTTTAGATAG	TTAA			

Figure 2.1 (D) Alignment of the protein sequences of the human and mouse HSF1.

```

mHSF2 MKQSSNVPAF LSKLWTLVEE THTNEFITWS QNGQSFLVLD EQRFAKEILP
hHSF2 MKQSSNVPAF LSKLWTLVEE THTNEFITWS QNGQSFLVLD EQRFAKEILP

mHSF2 KYFKHNNMAS FVRQLNMYGF RKVVHIESGI IKQERDGPVE FQHPYFKQGQ
hHSF2 KYFKHNNMAS FVRQLNMYGF RKVVHIDSGI VKQERDGPVE FQHPYFKQGQ

mHSF2 DDLLENIKRK VSSSKPEENK IRQEDLTKII SSAQKVQIKQ ETIESRSLSEL
hHSF2 DDLLENIKRK VSSSKPEENK IRQEDLTKII SSAQKVQIKQ ETIESRSLSEL

mHSF2 KSENESSLWKE VSELRAKHAQ QQQVIRKIVQ FIVTLVQNNQ LVSLKRKRPL
hHSF2 KSENESSLWKE VSELRAKHAQ QQQVIRKIVQ FIVTLVQNNQ LVSLKRKRPL

mHSF2 LLNTNGAPKK NLYQHIVKEP TDNHHHKVPH SRTEGLKSRE RISDDIIIYD
hHSF2 LLNTNGAQKK NLFQHIVKEP TDNHHHKVPH SRTEGLKPRE RISDDIIIYD

mHSF2 VTDDNVDEEN IPVIPETNED VVVDSN--Q YPDIVIVEDD NEDEYAPVIQ
hHSF2 VTDDNADEEN IPVIPETNED VISDPSNCSQ YPDIVIVEDD NEDEYAPVIQ

mHSF2 SGEQSEPAE PLRVGSAGSS SPLMSSAVQL NGSSSLTSED PVTMMDSILN
hHSF2 SGEQNEPAE SLSSGSDGSS -PLMSSAVQL NGSSSLTSED PVTMMDSILN

mHSF2 DNINLLGKVE LLDYLDSDIC SLEDFQAMLS GRQFSIDPDL LVD-----
hHSF2 DNINLLGKVE LLDYLDSDIC SLEDFQAMLS GRQFSIDPDL LVDLFTSSVQ

mHSF2 ----- -SENKGLEAT KSSVVQHVSE EGRKSKSKPD KQLIQYTAFP
hHSF2 MNPTDYINNT KSENKLETT KNNVVQPVSE EGRKSKSKPD KQLIQYTAFP

mHSF2 LLAFLDGNSA SAIEQGSTTA SSEVPSVVK PIEVDELLDS SLDPEPTQSK
hHSF2 LLAFLDGNPA SSVEQASTTA SSEVLSSVVK PIEVDELLDS SLDPEPTQSK

mHSF2 LVRLEPLTEA EASEATLFYL CELAPAPLDS DMPLLD
hHSF2 LVRLEPLTEA EASEATLFYL CELAPAPLDS DMPLLD

```

We found that mouse cells express two distinct HSF1 mRNA isoforms (HSF1- α and HSF1- β) that are generated by alternative splicing of the HSF1 pre-mRNA. The two HSF1 mRNA isoforms result from the inclusion (HSF1- α), or omission (HSF1- β), of a 66 nucleotide exon of the HSF1 gene, which encodes a 22 amino acid sequence. The insertion site of this 22 amino acid sequence in the HSF1- α isoform is located immediately adjacent to a C-terminal leucine zipper motif shown by other studies to be involved in maintenance of HSF1 in the non-DNA-binding control form (Rabindran et al., 1993; Zuo et al., 1994). Our results also show that the levels of the HSF1- α and HSF1- β mRNA isoforms are regulated in a tissue-dependent manner, with testis expressing predominantly the HSF1- β isoform while heart and brain express primarily the HSF1- α isoform.

In addition, we found that mouse cells also express two distinct HSF2 mRNA isoforms (HSF2- α and HSF2- β) that are generated by alternative splicing of the HSF2 pre-mRNA. The two HSF2 mRNA isoforms result from the inclusion (HSF2- α), or omission (HSF2- β), of a 54 nucleotide exon of the HSF2 gene, which encodes a 18 amino acid sequence. Like HSF1, the insertion site of this 18 amino acid sequence in the HSF2- α isoform is located immediately adjacent to a C-terminal leucine zipper motif (Rabindran et al., 1993; Zuo et al., 1994). Our results also show that the levels of the HSF2- α and HSF2- β mRNA isoforms are regulated in a tissue-dependent manner, with testis and brain expressing predominantly the HSF2- α isoform while heart, liver, and kidney express primarily the HSF2- β isoform. Furthermore, HSF2 isoform levels are regulated both in a developmental and cell type dependent manner in the testis. Newborn

mice express predominantly the HSF2- β isoform in the testis through day 14. Beginning around day 21 and in the adult mouse, the HSF2- α isoform is the predominant HSF2 isoform expressed in the testis. During spermatogenesis, pachytene spermatocytes and round spermatids express predominantly the HSF2- α isoform. We have also characterized both HSF2 isoforms with respect to transcriptional activity. In a luciferase reporter gene assay, HSF2- α is a 2.6-fold better transcriptional activator than the HSF2- β isoform. These data suggest that the HSF2 isoforms may have functionally distinct biological roles.

MATERIALS AND METHODS

Experimental Animals

CBA/J mice were obtained from Jackson Laboratory (Bar Harbor, ME) and maintained under a controlled light cycle (14 hrs. light:10 hrs. dark). Heart, brain, and testes were removed from mice at the age of 6-8 weeks, rapidly frozen on dry ice, and then stored at -80°C until use. These studies were conducted in accordance with the procedures described in the NIH Guide for the Care and Use of Laboratory Animals.

RT-PCR Analysis

Total RNA was prepared from adult mouse tissues by homogenization in guanidine isothiocyanate and centrifugation through cesium chloride, as described

previously (Sarge et al., 1994). For RT-PCR, reverse transcription coupled with polymerase chain reaction, total RNA (2-5 μ g) was reverse-transcribed at 42°C using random hexamer primers and AMV reverse transcriptase (6 U) in a 20 μ l reaction. Two oligonucleotide primers, which hybridize to nucleotides 1272-1293 (5'-GCTAA GTGAT CACCT GGATG CC-3') and 1730-1751 (5'-TCCCC TGGAC TACCC ACCTG TT-3') of the mouse HSF1 cDNA, were used to amplify 479 bp and 545 bp isoform products from the HSF1 cDNA. Two oligonucleotide primers, which hybridize to nucleotides 1171-1192 (5'- ACCCT GTGAC CATGA TGGAC TC-3') and 1623-1644 (5'-TGGCT TCACT AGCTT CCGCT TC-3') of the mouse HSF2 cDNA, were used to amplify 473 bp and 527 bp isoform products from the HSF2 cDNA. For both HSF1 and HSF2, an internal control 104 bp fragment was amplified from the mouse ribosomal protein S16 mRNA (5'-TCCAA GGGTC CGCTG CAGTC-3' and 5'-CGTTC ACCTT GATGA GCCCA TT-3') (14). A reaction cocktail containing oligonucleotide primers (200 ng each), [α -³²P]-dCTP (2 μ Ci at 3000 Ci/mmol), 10 X PCR buffer (10 mM Tris, pH 8.3, 50 mM KCl, 1.5 mM MgCl₂, 0.01% gelatin--Perkin Elmer) and AmpliTaq DNA polymerase (2.5 U, Perkin Elmer) was added to each reaction. The total volume was brought to 100 μ l with distilled water, and the sample overlaid with mineral oil. Amplification was carried out for 20 cycles using an annealing temperature of 65°C in a Perkin-Elmer Cetus thermal cycler. The amplified products were separated by electrophoresis on 5% polyacrylamide gels and visualized by film autoradiography. Intensity of bands in the RT-PCR analysis were quantified with a Molecular Dynamics Phosphorimager using the ImageQuant program (version 3.3), and the levels of the isoform bands were calculated after normalization to the S16 mRNA internal control.

Isolation and Cloning of HSF1 cDNA and Genomic DNA Sequences

The fragments of the HSF1 and HSF2 cDNAs spanning the alternative splice sites were obtained by RT-PCR methods from total RNA of mouse testis. Following reverse transcription of total RNA, cDNA fragments were amplified by PCR as described above with the exception that radioactivity was not incorporated and 30 cycles of PCR were used to amplify the DNA. HSF1 cDNA fragments were digested using the restriction endonucleases NcoI (1296 nt) and SacI (1549 nt) on opposite sides of the splice variant junctions and were subcloned into the pGEM-5Z (Promega, Madison, WI) plasmid vector. HSF2 cDNA fragments were subcloned into the plasmid vector pSP72 (Promega, Madison, WI) using the restriction endonucleases BglII (1315 nt) and HindIII (1595 nt) which are located on opposite sides of the splice variant region of the HSF2 cDNA. The sequences were determined by the Sanger dideoxy method according to the protocol from the Sequenase DNA sequencing kit (USB, Cleveland, OH).

The genomic DNA sequences of the HSF1 and HSF2 genes that comprise the alternative splice junctions were isolated from HSF1 and HSF2 genomic DNA phage clones obtained from a mouse genomic DNA library. The fragments containing the alternative splice junctions of HSF1 and HSF2 were subcloned into pGEM-5Z and pSP72 plasmids respectively using the restriction endonuclease sites indicated above. The sequences were determined by the Sanger dideoxy method according to the protocol from the Sequenase DNA sequencing kit (USB, Cleveland, OH).

Western Blot (Immunoblot) and Gel Mobility Shift Analysis

Mouse tissues and isolated spermatogenic cells (pachytene spermatocytes and round spermatids) were resuspended and boiled for 5 min in 2x Laemmli SDS-PAGE buffer [125 mM TrisHCl, pH 6.8, 20% glycerol, 4% sodium dodecylsulfate (SDS) and 200 mM dithiothreitol (DTT)] (Laemmli, 1970). Samples were electrophoresed on an 8% SDS-polyacrylamide gel (Laemmli, 1970) and transferred to nitrocellulose using a BIORAD Semidry transfer apparatus (BIORAD, Hercules, CA) according to the manufacturer's protocol. The blot was probed with the HSF2 polyclonal antiserum as previously described (Sarge et al., 1993). The native gel mobility shift assay was performed as described previously (Sarge et al., 1993) with a self-complementary consensus heat shock-element-containing oligonucleotide (5'-CTAGAAGCTTCTAGAAGCTTCTAG-3'), which contains four perfect inverted 5'-NGAAN-3' repeats.

HSF2 Transfection of NIH 3T3 Cells and Luciferase Assays

NIH 3T3 Cells were transfected with plasmid vectors which contained either the HSF2- α or HSF2- β cDNA under the control of the β -actin promoter and a reporter plasmid with the firefly luciferase gene under the control of the hsp promoter (Sarge et al., 1993). The β -actin-HSF2- α vector was made by subcloning the splice variant region of the HSF2- α cDNA from the pSP-HSF2- α vector described above into the β -actin-HSF2- β vector described previously using BglIII and HindIII. NIH 3T3 cells were

transfected using calcium phosphate described previously (Espeseth et al., 1989). In short, cells were seeded at 5×10^5 cells per 10 cm tissue culture plate in DMEM containing 10% fetal bovine serum and 50 $\mu\text{g/ml}$ gentamycin. The following day cells were transfected with 10 μg of DNA and incubated at 37° C overnight. Fresh medium was added the next morning. After 24h cells were harvested and whole cell extracts were made as previously described (Sarge et al., 1993). Luciferase assays were performed as previously described and the results were normalized to transfection efficiency as previously described (de Wet et al., 1987). Western blot and gel mobility shift assays were performed as described above.

RESULTS

Tissue distribution of HSF1 mRNA isoforms.

Previous western blot analysis of the HSF1 protein in NIH-3T3 cell extracts treated with potato acid phosphatase revealed the existence of two major HSF1 protein isoforms of approximately 69 and 71 kDa molecular weight (Sarge et al., 1993). We will refer to the 71 kDa protein as the HSF1- α isoform and the 69 kDa protein as the HSF1- β isoform. Phosphatase treatment was necessary to reveal these HSF1 protein isoforms because the HSF1 protein in unstressed cells exhibits multiple phosphorylation states, which results in a heterogeneous migration of the HSF1 protein on SDS-PAGE gel (Sarge et al., 1993). In order to determine whether the HSF1- α and HSF1- β protein isoforms arise via alternative splicing of the HSF1 pre-mRNA, we performed RT-PCR

analysis of HSF1 mRNA in various mouse tissues. For this analysis, we used primer pairs that amplify a region in the HSF1 mRNA that was suggested by previous sequence analysis to be subject to alternative splicing events. This sequence comparison of previously cloned human and mouse cDNAs revealed a 22 amino acid gap in homology between the mouse and human HSF1 (Figure 2.1, (Rabindran et al., 1991; Sarge et al., 1991)). The results of the RT-PCR analysis, shown in Figure 2.2 A, demonstrate the existence of two distinct HSF1 mRNA variants (HSF1- α and HSF1- β) in these tissues. This analysis also revealed that the levels of these two HSF1 mRNA isoforms are regulated in a tissue-dependent manner. Quantification of the results of the RT-PCR analysis revealed that heart and brain express 2.0 and 1.6-fold higher levels of the HSF1- α mRNA isoform, respectively, while testis expresses 2.2-fold higher levels of the HSF1- β mRNA isoform (Figure 2.2B).

Tissue distribution of HSF2 mRNA isoforms.

Similarly, western blot analysis of the HSF2 protein in mouse tissue extracts from heart, brain, testes, and isolated spermatogenic cell types (pachytene spermatocytes and round spermatids) revealed the existence of two major HSF2 protein isoforms of approximately 69 and 71 kDa molecular weight (Figure 2.3). Again, we will refer to the 71 kDa protein as the HSF2- α isoform and the 69 kDa protein as the HSF2- β isoform. It is unnecessary to treat extracts with potato acid phosphatase prior to analysis for HSF2 protein, as HSF2 does not contain the same phosphorylation-induced heterogeneous SDS-PAGE migration as does HSF1 (Sarge et al., 1993). In order to determine whether

the HSF2- α and HSF2- β protein isoforms arise via alternative splicing of the HSF2 pre-mRNA, we performed RT-PCR analysis of HSF2 mRNA in various mouse tissues. For this analysis, we used primer pairs that amplify a region in the HSF2 mRNA that was suggested by previous sequence analysis to be subject to alternative splicing events. This sequence comparison of previously cloned human and mouse cDNAs revealed a 18 amino acid gap in homology between the mouse and human HSF2 (Figure 2.1, (Sarge et al., 1991; Schuetz et al., 1991)). The results of the RT-PCR analysis, shown in Figure 2.4A, demonstrate the existence of two distinct HSF2 mRNA variants (HSF2- α and HSF2- β) in these tissues. This analysis also revealed that the levels of these two HSF2 mRNA isoforms are regulated in a tissue-dependent manner. Quantification of the results of the RT-PCR analysis revealed that heart and brain express 2.8 and 5.3-fold higher levels of the HSF2- β mRNA isoform, respectively, while testis overall expresses 1.9-fold higher levels of the HSF1- α mRNA isoform. Pachytene spermatocytes and round spermatids each express 2.6 and 2.1-fold higher levels of the HSF2- β mRNA isoform, respectively (Figure 2.4B).

Cloning of HSF1 cDNA isoforms.

In order to verify the identity of the HSF1 mRNA variants, the PCR products amplified from testis total RNA (as seen in Figure 2.2A) were cloned and sequenced. The sequence analysis, shown in Figure 2.5, reveals that the HSF1- β mRNA isoform corresponds to a previously cloned HSF1 cDNA (Sarge et al., 1991). The larger HSF1- α mRNA isoform differs from the HSF1- β isoform by the insertion of an additional 66

nucleotides, which encode a 22 amino acid sequence. The theoretical molecular weight of the additional 22 amino acids is 2.3 kDa, which is consistent with the difference in size between the HSF1- α and HSF1- β protein isoforms (71 and 69 kDa, respectively) (Sarge et al., 1993).

Cloning of HSF2 cDNA isoforms.

In order to verify the identity of the HSF2 mRNA variants, the PCR products amplified from testis total RNA (as seen in Figure 5A) were cloned and sequenced. The sequence analysis, shown in Figure 2.6, reveals that the HSF2- β mRNA isoform corresponds to a previously cloned HSF2 cDNA (Sarge et al., 1991). The larger HSF2- α mRNA isoform differs from the HSF2- β isoform by the insertion of an additional 54 nucleotides, which encode a 18 amino acid sequence. The theoretical molecular weight of the additional 18 amino acids is 2.0 kDa, which is consistent with the difference in size between the HSF2- α and HSF2- β protein isoforms (71 and 69 kDa, respectively) (Sarge et al., 1993).

Cloning of the HSF1 genomic DNA from the splice variant region.

In order to obtain definitive evidence that the HSF1- α and HSF1- β mRNA isoforms arise via an alternative splicing mechanism, the regions of the HSF1 gene corresponding to the putative alternative splice junctions were isolated from a genomic library and sequenced. This sequence analysis, shown in Figure 2.7, reveals the existence

of a 66 bp exon in the HSF1 gene that corresponds to the extra nucleotide sequence in the HSF1- α mRNA isoform. This exon is bounded by intronic sequences of 76 and 68 bp, both of which exhibit mammalian splice site consensus sequences. These results show that the HSF1- α and HSF1- β mRNA isoforms are generated by alternative splicing of the HSF1 pre-mRNA.

Shown in Figure 2.8 is a schematic representation of the alternative splicing events by which the HSF1- α and HSF1- β isoforms are generated. The additional 22 amino acid sequence (denoted SV) is inserted in the C-terminal region of the HSF1 protein, immediately adjacent to a previously identified leucine zipper motif (Leucine Zipper 4).

HSF1- α splicing creates a fifth potential leucine zipper.

Figure 2.9 shows that the addition of the extra 22 amino acid sequence in the HSF1- α protein results in the appearance of a new, previously unidentified leucine zipper motif in this HSF1 isoform, which we will refer to as Leucine Zipper 5 (LZ-5).

Comparison of the mouse HSF1- α sequence with the orthologous human and *Drosophila* HSF sequences shows that the heptad repeats of hydrophobic amino acids that comprise Leucine Zipper 5 (indicated by open and closed diamonds) have been evolutionarily conserved (17,15), suggesting that this leucine zipper motif may be important for HSF function. This figure also shows the proximity of this new Leucine Zipper 5 motif to the hydrophobic amino acid heptad repeats of the previously identified Leucine Zipper 4 (indicated by open and closed triangles). Leucine Zipper 4 has been shown to be

important for maintenance of HSF1 in the non-DNA binding state, presumably via its interaction with leucine zipper sequences in the N-terminal oligomerization domain (Rabindran et al., 1993; Zuo et al., 1994). The close spatial relationship of these two leucine zipper motifs suggests that Leucine Zipper 5 may also be involved in interactions important for the HSF1 non-DNA-binding state. The HSF1- β protein isoform, since it lacks the additional 22 amino acid sequence, does not contain the Leucine Zipper 5 motif.

Cloning of the HSF2 genomic DNA from the splice variant region.

In order to obtain definitive evidence that the HSF2- α and HSF2- β mRNA isoforms arise via an alternative splicing mechanism, the region of the HSF2 gene corresponding to the putative alternative splice junctions was isolated from a genomic library and partially sequenced. This sequence analysis, shown in Figure 2.10, reveals the existence of a 54 bp exon in the HSF2 gene that corresponds to the extra nucleotide sequence in the HSF2- α mRNA isoform. This exon is bounded by intronic sequences of approximately 1.8 kb and 2.3 kb, both of which exhibit mammalian splice site consensus sequences. These results show that the HSF2- α and HSF2- β mRNA isoforms are generated by alternative splicing of the HSF2 pre-mRNA.

Shown in Figure 2.11 is a schematic representation of the alternative splicing events by which the HSF1- α and HSF1- β isoforms are generated. The additional 18 amino acid sequence (denoted SV) is inserted in the C-terminal region of the HSF2 protein, immediately adjacent to a previously identified leucine zipper motif (Leucine Zipper 4).

Developmental Regulation of HSF2 mRNA Splicing.

HSF2 mRNA and protein levels are highly regulated during development and spermatogenesis (Sarge et al., 1994). Also, pachytene spermatocytes and round spermatids express high levels of HSF2- α , more than whole testes (Figure 2.4). Based on these facts, we sought to determine if the expression of the HSF2 isoforms was regulated during development. To this end, we performed RT-PCR on mRNA from testes harvested from mice at various stages of postnatal development. At seven days postpartum, testes contain only somatic cells. At this stage HSF2- β is the predominant isoform of HSF2 expressed in the testis. From days 14 and 21 through adulthood (six weeks), levels of the HSF2- α isoform increase (Figure 2.12a). Quantification of the RT-PCR analysis after normalization to the S-16 internal standard reveals that the change from HSF2- β to HSF2- α over the course of postnatal development is primarily due to increased levels of HSF2- α expression (Figure 2.12b). This result is consistent with the increase in germ cells relative to somatic cells with the onset of spermatogenesis.

Increased transcriptional activity of the HSF2- α isoform.

Finally, we sought to determine if there were functional differences between the HSF2 isoforms. To assess differences in transcriptional activity, the two isoforms were analyzed using a reporter gene assay. NIH 3T3 cells were cotransfected with an HSF2- α or HSF2- β expression plasmid and a reporter plasmid with the firefly luciferase gene

under the control of the mammalian hsp70 promoter. Transcriptional activity was measured as changes in luciferase activity relative to cells transfected with parental β -actin-1-neo parental vector the reporter plasmid. Luciferase activity was determined by measuring the amount of light given off from cell extracts when luciferin and ATP were added. These results were normalized to total protein in the cell extracts.

From this analysis, we determined that HSF2- β and HSF2- α were capable of activating transcription of the reporter gene 3.6-fold and 9.6-fold respectively (Figure 2.13a). Analysis of the HSF2 protein levels of the transfected cell extracts used for the luciferase assays by western blotting indicates that differences in the transcriptional activity were not due to differences in transfection efficiency, expression levels, or overall protein stability. Both HSF2- α and HSF2- β transfected cells had relatively similar protein levels (Figure 2.13b). Also, levels of HSF2- α and HSF2- β were each significantly increased in the respective cotransfected cell extracts over the cells transfected with the reporter plasmid alone. Furthermore, gel mobility shift analysis revealed that both the HSF2- α and HSF2- β transfected cells had similar levels of HSE DNA binding activity (Figure 2.13c). Thus inclusion of the 18 amino acid peptide confers a 2.6 fold greater transcriptional potency on the HSF2- α isoform over HSF2- β . These data suggest that HSF2- α may be playing a functionally distinct role from HSF2- β , by providing increased levels of transcription of hsp genes in cells expressing predominantly the HSF2- α isoform. This may particularly relevant to the process of spermatogenesis, as pachytene spermatocytes and round spermatids express predominantly the HSF2- α isoform in the DNA binding form.

Figure 2.2: RT-PCR analysis of HSF1 mRNA isoforms in mouse tissues.

(A) Total RNA from mouse heart (H), brain (B), testis (T), was subjected to RT-PCR analysis using an oligonucleotide primer pair that amplifies the region corresponding to nucleotides 1272 to 1751 of the full-length mouse HSF1 cDNA (16). (B) Quantification of HSF1- α and HSF1- β mRNA isoform levels in mouse tissues. The HSF1- α and HSF1- β RT-PCR bands in panel A were quantified and normalized to values of S16 mRNA internal control bands.

Figure 2.2: RT-PCR analysis of HSF1 mRNA isoforms in mouse tissues.

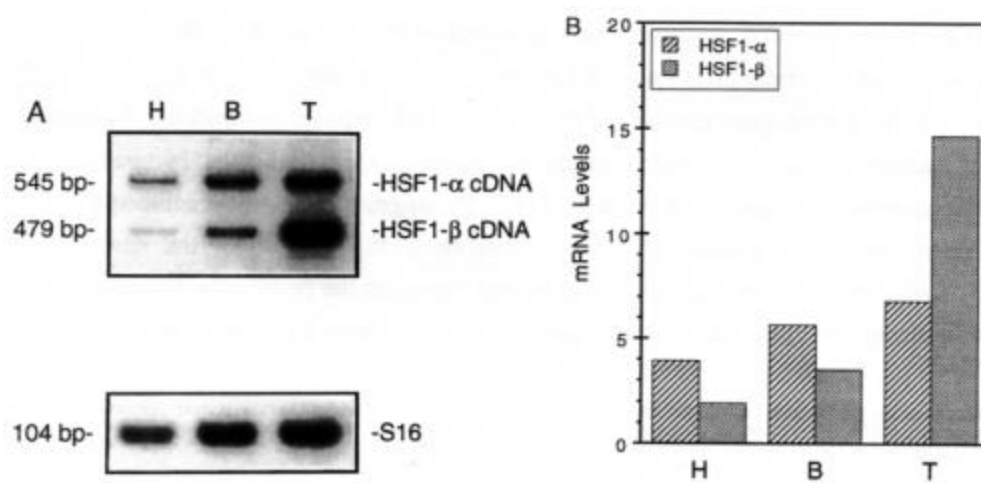

Figure 2.3: Western blot analysis of HSF2 protein from mouse tissues.

Western blot analysis of HSF2 protein in mouse tissue extracts from heart (H), brain (B), testes, and the isolated spermatogenic cell types pachytene spermatocytes (PS) and round spermatids (RS) reveals the existence of two major HSF2 protein isoforms of approximately 69 and 71 kDa molecular weight.

Figure 2.3: Western blot analysis of HSF2 protein from mouse tissues.

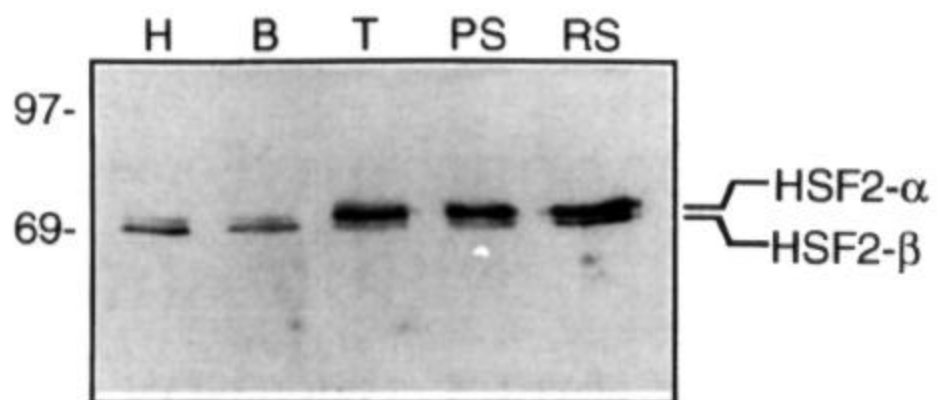

Figure 2.4: RT-PCR analysis of HSF2 mRNA isoforms in mouse tissues.

(A) Total RNA from mouse heart (H), brain (B), testis (T), pachytene spermatocytes (PS), and round spermatids (RS) was subjected to RT-PCR analysis using an oligonucleotide primer pair that amplifies the region corresponding to nucleotides 1171 to 1643 of the full-length mouse HSF2 cDNA (16). (B) Quantification of HSF2- α and HSF2- β mRNA isoform levels in mouse tissues. The HSF1- α and HSF1- β RT-PCR bands in panel A were quantified and normalized to values of S16 mRNA internal control bands.

Figure 2.4: RT-PCR analysis of HSF2 mRNA isoforms in mouse tissues.

Figure 2.5: Nucleotide and deduced amino acid sequences of HSF1 mRNA isoform cDNAs.

RT-PCR products corresponding to HSF1- α and HSF1- β mRNA isoforms (as shown in Figure 3A) were isolated, subcloned, and sequenced. The nucleotide and deduced amino acid sequences shown correspond to the region of variation between the HSF1- α and HSF1- β mRNA isoforms. Numbers refer to nucleotide position relative to the previously cloned full-length mouse HSF1 cDNA (Sarge et al., 1991).

Figure 2.6: Nucleotide and deduced amino acid sequences of HSF2 mRNA isoform cDNAs.

RT-PCR products corresponding to HSF2- α and HSF2- β mRNA isoforms (as shown in Figure 5A) were isolated, subcloned, and sequenced. The nucleotide and deduced amino acid sequences shown correspond to the region of variation between the HSF2- α and HSF2- β mRNA isoforms. Numbers refer to nucleotide position relative to the previously cloned full-length mouse HSF2 cDNA (Sarge et al., 1991).

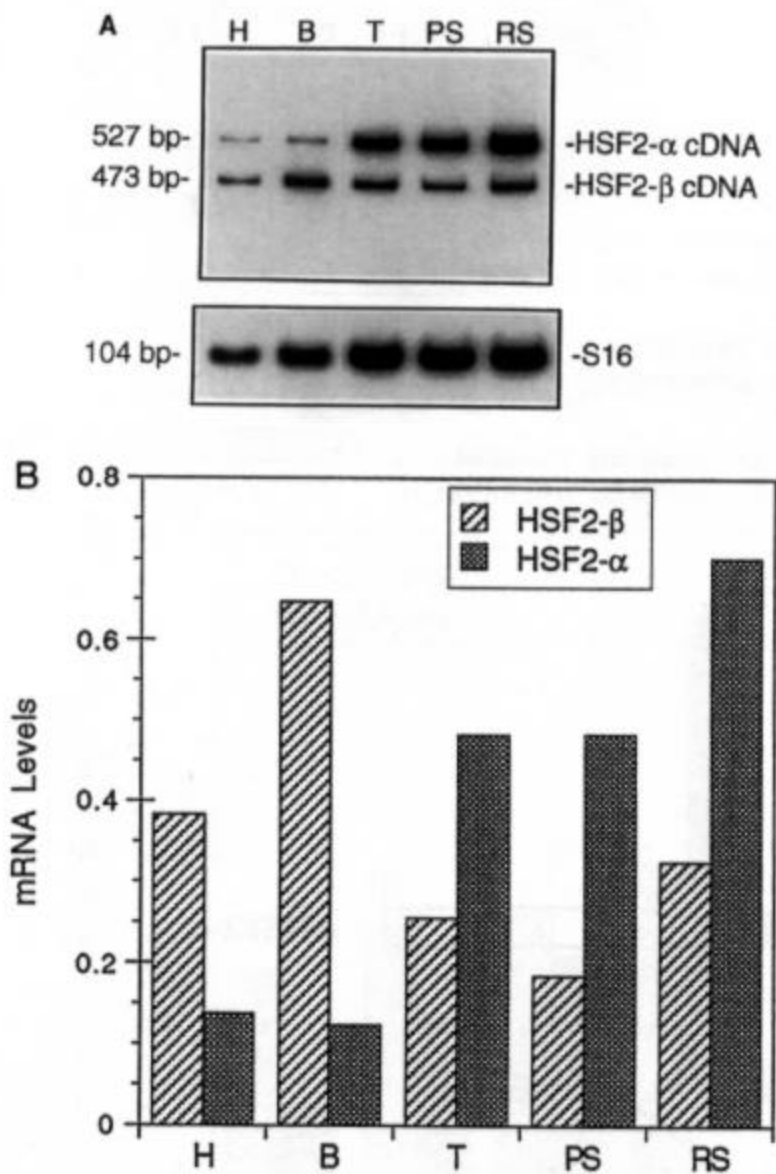
Figure 2.6: Nucleotide and deduced amino acid sequences of HSF2 mRNA isoform cDNAs.

```

    asp leu leu val asp leu phe thr ser ser val gln met asn pro thr
[--- GAT CTT CTG GTT GAT CTT TTC ACT AGT TCT GTG CAG ATG AAT CCC ACA
[--- GAT CTT CTG GTT GAT - - - - - - - - - - - - - - - - - - - -
    |
    1317

    asp asn ile asn asn thr lys ser glu asn lys gly
GAT AAC ATC AAT AAT ACA AAA TCT GAG AAT AAG GGA ---]mHSF2- $\alpha$  cDNA
- - - - - - - - - - - - - - - - - - - - - - - - - - - TCT GAG AAT AAG GGA ---]mHSF2- $\beta$  cDNA
    |
    1347

```

Figure 2.7: Sequence of HSF1 gene regions corresponding to alternative splice junctions.

An HSF1 genomic fragment containing the exon-intron boundaries of interest was isolated from a mouse genomic library, subcloned, and sequenced. Exons are shown as bold capital type while introns are shown as normal lower-case type. Numbers at the beginning and end of the genomic sequences are nucleotide positions relative to the full-length mouse HSF1 cDNA (Sarge et al., 1991), which are the same as those indicated in Figure 6 in order to allow easy comparison of the corresponding HSF1 mRNA isoform and gene sequences.

Figure 2.7: Sequence of HSF1 gene regions corresponding to alternative splice junctions.

```

1361 AGTGCCCTGC TGGACgtgag tctggtcatc cctaccacc ctgctccatc ctgcccacaa
TCACGGGACG ACCTGcactc agaccagtag ggatgggtgg gacgaggtag gacgggtgtt

gccagccctg actccctccc tctcctgca gCTATTCAGC CCCTCGGTGA CCATGCCCGA
cggtcgggac tgagggaggg aggaggacgt cGATAAGTCG GGGAGCCACT GGTACGGGCT

CATGAGCCTG CCTGACCTGG ACTGCAGCCT GGCCAGCgtg cgtaggcggg caggggtgggg
GTACTCGGAC GGACTGGAC TGACGTCGGA CCGGTCGcac gcatccgccc gtcccacccc

ggggcagagg ggggccatca acaacctatg tgttcctgtc cacagATTCA GGAGCTTCGT 1390
ccccgtctcc ccccggtagt tgttggatac acaaggacag gtgtcTAAGT CCTCGAAGAC

```

Figure 2.8: Schematic representation of HSF1 mRNA alternative splicing.

Schematic representation of HSF1 mRNA alternative splicing pathways and functional domains of HSF1- α and HSF1- β protein isoforms. The HSF1 exon encoding the 22 amino acid sequence which differs in the HSF1 isoforms is indicated (SV), along with the conserved DNA-binding domain, oligomerization domain (LZ's 1, 2, 3), and carboxy-terminal leucine zipper motif (LZ-4).

Figure 2.8: Schematic representation of HSF1 mRNA alternative splicing.

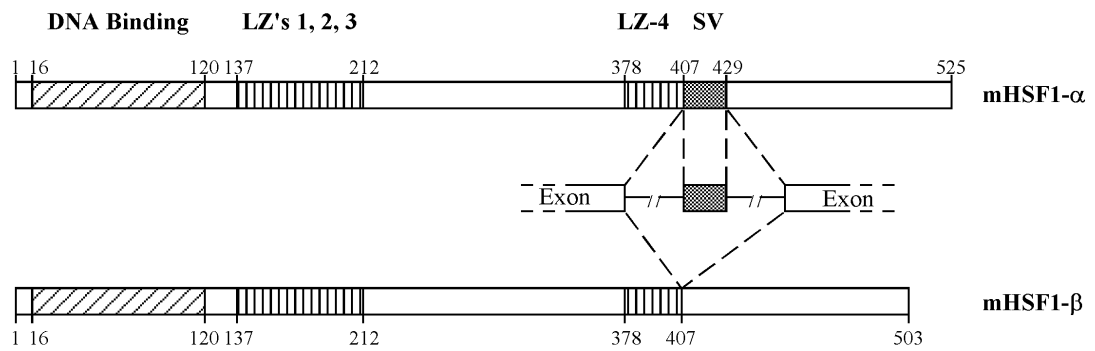

Figure 2.9: Novel leucine zipper motif in HSF1-a.

Regions of the amino acid sequences of the mouse HSF1- α , human HSF1 and *Drosophila* HSF homologs corresponding to leucine zipper 4 (LZ-4) and the alternative splice junction of the mouse HSF1 protein were aligned. The sequences were then analyzed to identify potential heptad hydrophobic amino acid repeats characteristic of leucine zipper motifs. Open (Δ) and closed (\blacktriangle) triangles correspond to the two registers of the previously identified LZ-4 (15). Open () and closed (\blacklozenge) diamonds indicate the hydrophobic amino acids which comprise the newly identified leucine zipper 5 (LZ-5). Numbers at the beginning and end of the sequences refer to positions relative to the published full-length amino acid sequences.

Figure 2.9: Novel leucine zipper motif in HSF1-a.



Figure 2.10: Sequence of HSF2 gene regions corresponding to alternative splice junctions.

An HSF2 genomic fragment containing the exon-intron boundaries of interest was isolated from a mouse genomic library, subcloned, and partially sequenced. Exons are shown as bold capital type while introns are shown as normal lower-case type. Numbers at the beginning and end of the genomic sequences are nucleotide positions relative to the full-length mouse HSF2 cDNA (Sarge et al., 1991), which are the same as those indicated in Figure 7 in order to allow easy comparison of the corresponding HSF1 mRNA isoform and gene sequences.

Figure 2.10: Sequence of HSF2 gene regions corresponding to alternative splice junctions.

```

1317 GATCT TCTGGTTGAT gtaggtatth ttgatactct ttactatact ggtggthttht gtaactaca
CTAGA AGACCAACTA catccataaa aactatgaga aatgatatga ccaccaaaaa catgaatgt

tgtgccattta aaatcaatac totthgtatth tacgththt // ttaaacttht catctththt
acacggtaaat thtagthtatg agaacataag atgcgaaag // aattgaaata gtagaaaaaa

gththgtctt thcagCTTHHCACTAGTHH GTGCAGATGA ATCCACAGA TAACATCAAT ATACA
caaaccagaa aagthGAAAAGTGATCAAGA CAGTHHACT TAGGTHHCT ATTGTHHTA THHT

AAAgt aagththaatc catgthgthc aggacccata // agga atgthaatag thattctaca
THHca thcaaattag gthacaagag thctggtht // thct thacattthc athaagatgt

thththtatg TCTGAGAATA AGGGA 1347
aaaaaatatc AGACTTHHT THHCT

```

Figure 2.11: Schematic representation of HSF2 mRNA alternative splicing.

Schematic representation of HSF2 mRNA alternative splicing pathways and functional domains of HSF2- α and HSF2- β protein isoforms. The HSF2 exon encoding the 18 amino acid sequence which differs in the HSF2 isoforms is indicated (SV), along with the conserved DNA-binding domain, oligomerization domain (LZ's 1, 2, 3), and carboxy-terminal leucine zipper motif (LZ-4).

Figure 2.11: Schematic representation of HSF2 mRNA alternative splicing.

Figure 2.12: RT-PCR analysis of HSF2 isoforms during testis development.

RT-PCR analysis of testis expressed HSF2 isoforms during postnatal development. (A) Total RNA isolated from testes of mice at 7, 14, and 21 days of postnatal development and from adult mice (6 wk) was analyzed by RT-PCR. (B) The RT-PCR bands from panel A were quantified and normalized to the S-16 internal control. A refers to adult mice.

Figure 2.12: RT-PCR analysis of HSF2 isoforms during testis development.

Figure 2.13: Reporter gene analysis of HSF2-a and HSF2-b isoforms.

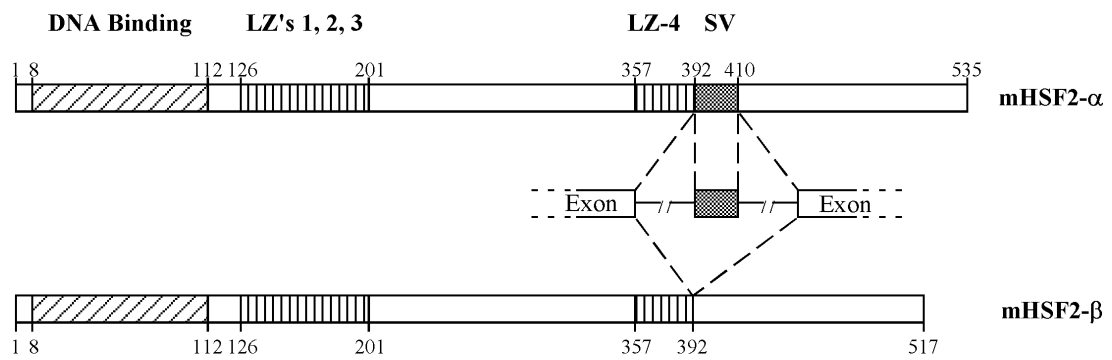
(A) HSF2- α and HSF2- β expression plasmids were cotransfected with an hsp70 promoter-luciferase reporter plasmid into NIH 3T3 cells. Cells were assayed for luciferase activity and normalized to total protein and luciferase activity from NIH3T3 cells transfected with the reporter gene and parental expression vector. Cells transfected with HSF2 β and HSF2 α express 3.6 (± 0.5) and 9.6 (± 1.1) fold more luciferase (respectively) than control transfected NIH 3T3 cells. (B) An immunoblot of extracts from NIH 3T3 cells transfected with the reporter plasmid alone (lane 1), HSF2- β (lane 2), or HSF2- α (lane 3) was probed with an antibody against HSF2. Relative molecular weight marker positions are indicated on the left (size in kDa). (C) Gel mobility shift analysis of extracts from NIH 3T3 cells transfected with the reporter plasmid alone (lane 1), HSF2- β (lane 2), or HSF2- α (lane 3) using an idealized-HSE containing oligonucleotide as a probe. The position of the HSF2-specific mobility shift (HSF2), a nonspecific mobility shift (NS) and the free probe (F) are indicated on the left. Calcium phosphate transfections performed by Dr. Kevin Sarge.

Figure 2.13: Reporter gene analysis of HSF2-a and HSF2-b isoforms.

DISCUSSION

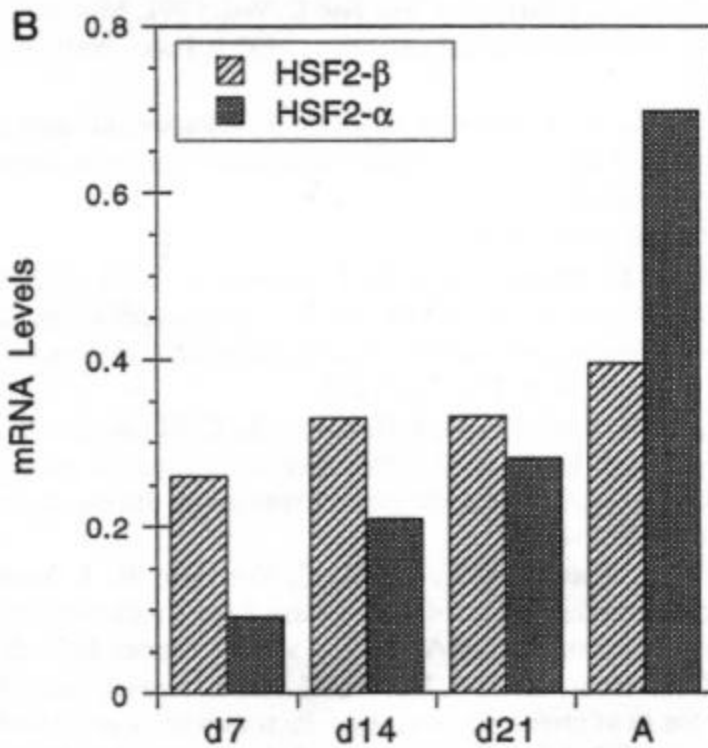
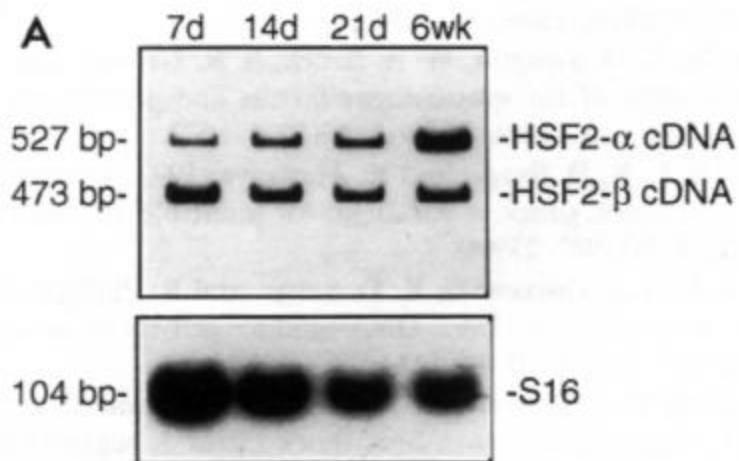
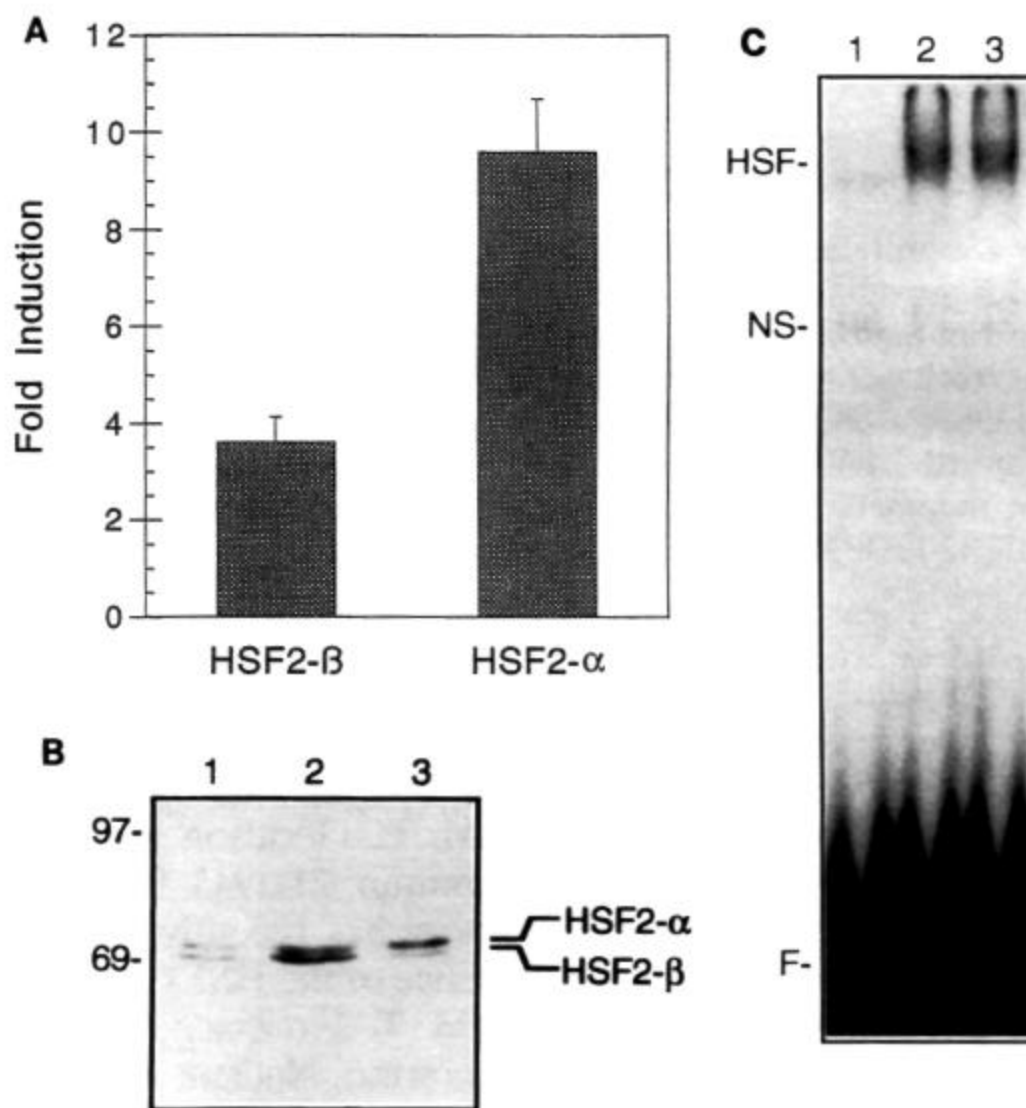
HSF1 alternative splicing—implications for differential stress response activation.

These results reveal the existence of a new mechanism for the regulation of HSF1 in mammalian cells. Mouse cells express two distinct HSF1 isoforms, HSF1- α and HSF1- β , which arise via alternative splicing of the HSF1 pre-mRNA. This alternative splicing results in the inclusion of a 66 bp exonic sequence which encodes 22 amino acids not found in the shorter HSF1- β isoform of the protein. This splicing event occurs immediately carboxy-terminal to the predicted leucine zipper (LZ-4), and inclusion of this 22 amino acid sequence creates a fifth predicted leucine zipper motif. In addition, the expression of these two HSF1 isoforms is regulated in a tissue-dependent manner.

We can postulate two possible functions for the regulated expression of the two HSF1 isoforms. The first possibility is that the additional 22 amino acid sequence present in the HSF1- α isoform may function to increase the transcriptional activity of the HSF1 protein, similar to the effect observed for with HSF2 isoforms. Therefore, we hypothesize that the levels of the HSF1 protein isoforms may be regulated in order to modulate the potency of the cellular stress response in cells of different tissues.

A second possibility is that the extra 22 amino acids in the HSF1- α protein functions to modulate the stability of the non-DNA binding form of this HSF1 protein isoform. As shown above (Figure 10), the insertion of the extra 22 amino acid sequence in the HSF1- α protein isoform creates a potential fifth leucine zipper motif which immediately follows the previously identified leucine zipper 4 (Rabindran et al., 1991).

Leucine zipper 4 has been implicated in the maintenance of HSF1 in the monomeric non-DNA binding form, presumably via interactions with leucine zipper sequences in the N-terminal oligomerization domain. We hypothesize that this fifth leucine zipper may act in concert with leucine zipper 4 to further stabilize the monomeric non-DNA binding form of the HSF1- α protein isoform. We further hypothesize that the HSF1- α isoform, due to the inclusion of this fifth leucine zipper motif, may have an activation temperature setpoint that is slightly higher than the HSF1- β isoform, which lacks this motif.

Consistent with this, testis, which has an HSF1 activation temperature of 35°C expresses predominantly HSF1- β while heart and brain, which have an HSF1 activation temperature of 42°C, express predominantly HSF1- α (Sarge et al., 1995a, Sarge et al.). It is unlikely, however, that differences in HSF1 isoform expression explain this difference in HSF1 activation temperature. Cellular environment likely dictates the activation temperature for HSF1. When *drosophila* HSF, which is normally activated at 30°C, is added to human cell extracts, its set point is reprogrammed to 42°C, that of the human HSF1 (Clos et al, 1993). Therefore, it is possible that cells express both HSF1- α and HSF1- β isoforms because together they provide a larger temperature range over which the cellular stress response can be induced, thus conferring an increased ability to respond to environmental stresses of differing severity.

HSF2 alternative splicing—implications for spermatogenic gene regulation.

The results in this work have shown that mice express two distinct protein isoforms of HSF2 and that these isoforms arise from alternative mRNA splicing. This

alternative splicing event results in the inclusion of a 54 bp exon, which encodes an 18 amino acid sequence not found in the HSF2- β isoform. We have shown that this splicing event is tissue-dependent as well as germ cell type-dependent in the testis. We have also shown that there is a regulated switch from HSF2- β to HSF2- α during postnatal development in the mouse testis. Furthermore, we have shown that the inclusion of this 18 amino acid sequence immediately following the carboxy-terminal leucine zipper (LZ4) has the functional consequence of making the HSF2- α isoform a 2.6 fold more potent transcriptional activator than the HSF2- β isoform. As both isoforms have similar DNA binding properties, this effect is likely due to increased transactivating potential. The most probable explanation for this is that inclusion of the 18 amino acid sequence causes a more favorable interaction with the transcriptional machinery. This could be by the addition of a transactivation domain or by favorably affecting the position of an existing transactivation domain. Previous studies have demonstrated that the transcription factor cyclic-AMP response element modulator (CREM) is regulated by alternative splicing during spermatogenesis (Delmas et al., 1993; Foulkes et al., 1992). CREM switches from transcriptional repressor forms (CREM- α , - β , - γ) to a testis specific transcriptional activator form (CREM- τ) with the inclusion of two glutamine-rich transactivation domains (Foulkes et al., 1992).

Previous data from our lab has shown that HSF2 is subject to complex regulation during spermatogenesis. In the testis, HSF2 expression is upregulated in a cell type, spermatogenic stage, and developmentally-dependent manner. Additionally, our lab has shown that unlike in somatic tissues, HSF2 is found in the DNA binding form in the testis (Sarge et al., 1994). To these complex regulatory regiments, we can now add attenuation

of HSF2 transcriptional activity by alternative mRNA splicing. HSF2 expressed in testis cell extracts is capable of binding sequences in the promoter of the hsp70.2 gene, a testis-specific hsp70 family member (Sarge et al., 1994). We, therefore, hypothesize that the switch from HSF2- β to HSF2- α during spermatogenesis functions to upregulate one or more hsp genes required to facilitate the unique pattern of protein expression found in male germ cells. Future studies will be required to identify the *cis*- and *trans*-acting factors involved in the overall upregulation of HSF2 as well as those involved in the switch in mRNA splicing. Based on the complexity of HSF2 regulation in the testis, however, these studies are likely to provide insights into the mechanisms of gene regulation used during spermatogenesis.

Chapter 3

SUMO-1 Modification of HSF2

INTRODUCTION

Biology's central dogma states that the genetic information of a cell is stored as DNA. This information is first transcribed or copied to a transient RNA intermediate and then is translated from RNA into proteins that make up the functional components of the cell (Alberts et al., 1989). While the concepts imbedded in this central dogma are inherently correct, they are also greatly over simplified. There are many other levels of regulation that impinge on the ultimate function of a gene product. One mechanism of regulation that researchers are finding increasingly important is that of post-translational protein modification. Examples of this include phosphorylation, proteolytic processing, glycosylation, covalent lipid modification, and protein coupling (Alberts et al., 1989).

Of interest to this work is post-translational protein coupling, or the covalent attachment of a polypeptide chain to another protein. The most common example of this is ubiquitination. Ubiquitin is a 7 kDa polypeptide that is covalently bonded to the ϵ -amino group of a lysine residue in the target protein by a multi-enzyme ligase complex (Hershko and Ciechanover, 1998; Hochstrasser, 1996). The first step involves the proteolytic processing of ubiquitin to expose a diglycine motif at the C-terminus. The processed ubiquitin is then covalently attached to a cysteine residue in the E1 or ubiquitin activating enzyme (Uba1 in *S. cerevisiae*) in an ATP dependent fashion (Figure 3.1).

Figure 3.1: Schematic representation of the ubiquitination cycle.

Ubiquitin (Ub) is conjugated to a ubiquitin activating enzyme (E1) in an ATP dependent fashion. E1 transfers the ubiquitin to one of several ubiquitin conjugating enzymes (E2). E2 then transfers ubiquitin to a target protein with the assistance of one of many ubiquitin ligases (E3). This cycle of ubiquitin attachment to a target protein can be repeated multiple times leading to polyubiquitination and ultimately protein degradation by the 26S proteasome. Degradation of the target protein leads to release of free ubiquitin which can then be reused in the ubiquitination cycle. (Adapted from Varshavsky, 1997).

Figure 3.1: Schematic representation of the ubiquitination cycle.

26S Proteasome & Degradation

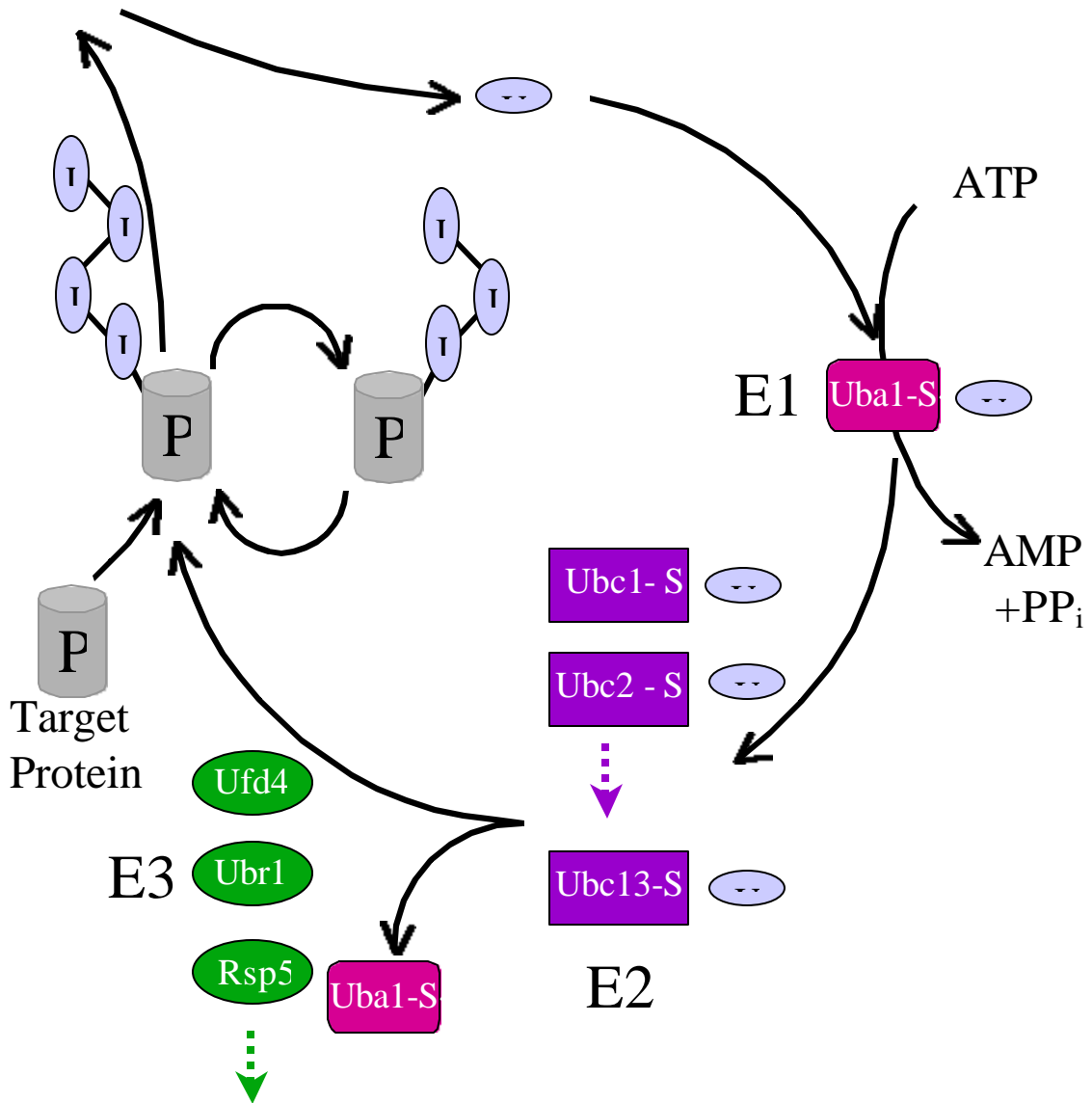

An E2 or ubiquitin conjugation enzyme then receives the ubiquitin from the E1 in a transthioesterification reaction. The E2 in conjunction with an E3 or ubiquitin ligase (often for specificity) catalyzes the transfer of ubiquitin to the target protein in an amidation reaction. Interestingly, ubiquitin contain several lysine residues (predominantly Lys-48) which can serve as target residues for further ubiquitination, thus allowing formation of ubiquitin polymers. This polyubiquitination serves as a targeting signal for the 26S proteasome and ultimately degradation of the target protein (Hershko and Ciechanover, 1998; Hochstrasser, 1996; Varshavsky, 1997).

In the past several years, a number of reports have described several proteins with similarity to ubiquitin. These proteins include Rub1, UCRP, FAU, and SUMO-1 (Mahajan et al., 1997; Matunis et al., 1996; Rao-Naik et al., 1998; Vierstra and Callis, 1999). At least in the cases of Rub1, or its mammalian homolog Nedd8, and SUMO-1, these seem to be similar but functionally distinct homologs, both with respect to ubiquitin and each other. Both use ligase complexes discrete from ubiquitin and discrete from each other (Desterro et al., 1999; Desterro et al., 1997; Gong and Yeh, 1999; Okuma et al., 1999). In addition, they modify different proteins.

SUMO-1 is a 97 amino acid, 17 kDa polypeptide which shares 18% amino acid sequence identity with ubiquitin. Originally SUMO-1 was identified as a modifier of the Ran GTPase activating protein, RanGAP1. It was subsequently and independently discovered by a number of different laboratories and given an assortment of names—SUMO-1, UBL1, GMP1, PIC1, Sentrin, Smt3 in *S. cerevisiae*, and Pmt3P in *S. pombe*. SUMO-1 is required for viability (Hodges et al., 1998; Kretz-Remy and Tanguay, 1999;

Mahajan et al., 1997; Matunis et al., 1996; Saitoh et al., 1997). In *S. cerevisiae*, Smt3 is required for entry into the mitotic phase of the cell cycle (Li and Hochstrasser, 1999), and in *S. pombe*, PmtP3 is required for control of telomere length and chromosomal segregation (Tanaka et al., 1999).

SUMO-1 is a member of a family of at least three SUMO proteins in mammalian cells, named SUMO-1, SUMO-2 and SUMO-3 (Kamitani et al., 1998a; Saitoh and Hinchey, 2000). SUMO-1 is 48% identical to SUMO-2 and 46% identical to SUMO-3, while SUMO-2 and SUMO-3 are 95% identical to each other. SUMO-2/3 represent a larger portion of the SUMO modified proteins in cells than does SUMO-1. In addition, a large pool of unconjugated SUMO-2/3 exists in cells (Saitoh and Hinchey, 2000).

Interestingly the relative amount of conjugated SUMO-2/3 increases when cells are exposed to protein damaging stresses such as heat shock, oxidative stress, or the protease inhibitor MG132 (Saitoh and Hinchey, 2000). SUMO-1 and SUMO-2/3 appear to colocalize to the same nuclear domain structures, but SUMO 2/3 does not appear to be conjugated to the predominant SUMO-1 target, RanGAP1 (Saitoh and Hinchey, 2000). Thus, SUMO-1 and SUMO 2/3 may have some overlap in function, but do represent functionally distinct members within the SUMO protein family. I will focus on SUMO-1 except where noted.

The tertiary structure for SUMO-1 has been solved and appears to be virtually superimposable with the structure of ubiquitin. Both ubiquitin and SUMO-1 have a five β -sheet, two α -helix, $\beta\beta\alpha\beta\beta\alpha\beta$ fold (Bayer et al., 1998). A key difference, however, is that the surface of SUMO-1 contains a groove region that is highly acidic, which ubiquitin lacks (Bayer et al., 1998). Strikingly, the SUMO-1 binding surface of Ubc9, the SUMO-

1 conjugating enzyme (E1), has two pockets of highly basic residues that receive the acidic residues of SUMO-1. Thus this difference in surface charge likely explains how the conjugating enzymes for SUMO-1 and ubiquitin can discriminate between the two (Liu et al., 1999).

In addition to structural similarities, SUMO-1 shares other similarities with ubiquitin. Like ubiquitin, SUMO-1 is translated as a protein that requires proteolytic processing. SUMO-1 is initially a 101 amino acid peptide that must have four amino acids at the C-terminus removed to expose a diglycine motif (Matunis et al., 1996; Matunis et al., 1998). The protease that is responsible for processing SUMO-1 *in vivo* has not been definitively identified. One candidate activity has been described in bovine brain extracts. In an *in vitro* assay, this 30 kDa activity is capable of processing SUMO-1 to the 97 amino acid form (Suzuki et al., 1999).

SUMO-1 also uses a multi-enzyme ligase complex to attach to target proteins. The processed SUMO-1 is a substrate for the SUMO E1, which is a heterodimer of two proteins called SAE1 and SAE2 (for SUMO-1 Activating Enzyme) (Figure 3.2) (Desterro et al., 1999; Okuma et al., 1999).

Figure 3.2: Schematic representation of the SUMO-1 modification cycle.

SUMO-1 is covalently attached to the SUMO-1 activating enzyme heterodimer (E1). E1 transfers SUMO-1 to the SUMO-1 conjugating enzyme, Ubc9 (E2). Ubc9 transfers SUMO-1 directly onto the target protein. Notice how simplified the SUMO-1 modification cycle is relative to the ubiquitination cycle. SUMO-1 uses only one E2 and no E3. Also, proteins can only be mono-SUMO-1 modified. SUMO-1 modification functions to alter the function of the target protein rather than to target it for degradation. Several SUMO-1 specific proteases indicate that the process of SUMO-1 modification is reversible and that SUMO-1 can be reutilized like ubiquitin. (Adapted from Varshavsky, 1997).

Figure 3.2: Schematic representation of the SUMO-1 modification cycle.

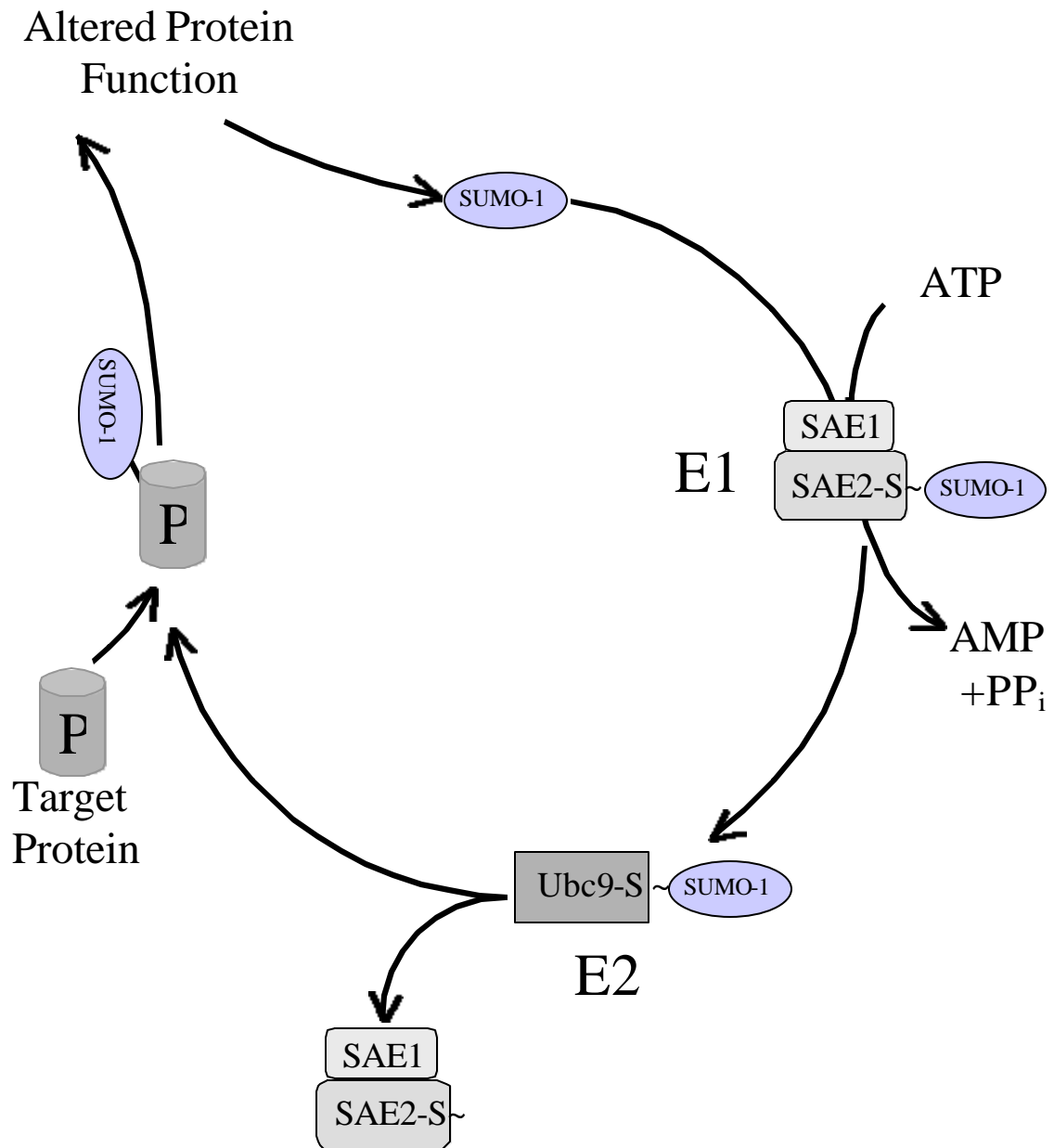

SAE1 is homologous to the N-terminus of the ubiquitin E1 and SAE2 shares homology with the C-terminus of the ubiquitin E1. Cys-173 of SAE2 serves as the acceptor residue for SUMO-1. Ubc9 is the E2 for SUMO-1. It receives the SUMO-1 from SAE1/2 and transfers it to the target protein (Desterro et al., 1997; Okuma et al., 1999). All SUMO-1 modified proteins characterized to date interact with Ubc9 directly, arguing that SUMO-1 may not require a separate E3 ligase for specificity (Duprez et al., 1999; Kim et al., 1999; Lee et al., 1998; Poukka et al., 1999). Supporting this idea is the fact that SUMO-1 modification can be reconstituted *in vitro* with only ATP, SUMO-1, SAE1, SAE2, Ubc9, and a target protein such as PML or RanGAP1 (Duprez et al., 1999; Lee et al., 1998).

Initial characterization of SUMO-1 modified proteins was hindered by an activity that hydrolyzed the SUMO-1 from the modified proteins, suggesting that like ubiquitin SUMO-1 is a reversible modification. Several proteins with SUMO-1 specific protease activity have been described. The first sumo-1 specific protease, Ulp1, was identified from the budding yeast *S. cerevisiae* and is unrelated to any ubiquitin specific protease. Ulp1 is capable of hydrolyzing the isopeptide bond from Smt3 (the yeast homolog of SUMO-1) modified proteins but not from those modified by ubiquitin. Mutations in Ulp1 cause an accumulation of Smt3 modified proteins and an arrest in the G₂/M phase of the cell cycle (Li and Hochstrasser, 1999). Recently, the human SENP1 was identified as a protease that is capable of removing SUMO-1 from modified proteins. SENP1 specifically hydrolyzes the isopeptide bond of SUMO-1 modified proteins, but not NEDD8 or ubiquitin (Gong et al., 2000). SENP1 is homologous to Ulp1, but not to ubiquitin specific proteases. Interestingly, SENP1 *in vivo* appears to selectively remove

SUMO-1 from nuclear domain proteins like PML and not from RanGAP1 which is located at the nuclear pore. Presumably this is due to SENP1's localization within the nucleus (Gong et al., 2000). Additionally the 30 kDa activity from bovine brain extracts which is capable of processing SUMO-1 also appears to be a SUMO-1 specific protease (Suzuki et al., 1999).

SUMO-1 modification of proteins does not appear to target proteins for degradation. In SUMO-1, the homologous residue to Lys-48 in ubiquitin (required for polyubiquitination) is a glutamine. No evidence to date has been found for the formation of SUMO-1 polymers. Consistent with this, SUMO-1 appears to have a number of other functions in the cell (Hodges et al., 1998; Kretz-Remy and Tanguay, 1999; Saitoh et al., 1997). For RanGAP-1, SUMO-1 modification is required for localization to the nuclear pore complex. RanGAP1 is the GTPase activating protein for Ran, a protein involved in nuclear import. Two species of RanGAP1 exist in the cell, a 70 kDa form and a 90 kDa form. The 90 kDa form is highly enriched in nuclear extracts and was found to be SUMO-1 modified (Matunis et al., 1996; Matunis et al., 1998). SUMO-1 modification of RanGAP1 is required for its association with nup358—also called RanBP—a Ran binding protein in the nuclear pore complex. Consistent with this finding, SUMO-1 modification of RanGAP1 is required for its association with the nuclear pore complex (Mahajan et al., 1997; Mahajan et al., 1998; Matunis et al., 1996; Matunis et al., 1998).

For I κ B and possibly p53, SUMO-1 modification appears to stabilize these proteins. NF κ B and I κ B form a latent or inactivate complex in cells. I κ B performs a dual function in this complex by binding to NF κ B to mask its nuclear localization signal and to inhibit NF κ B's DNA binding and transactivating activity. Upon stimulation (TNF α ,

PMA, etc.) I κ B α is phosphorylated on two serine residues (Jaffray et al., 1995; Kroll et al., 1997). These phosphorylation events trigger and are required for polyubiquitination of I κ B at two lysine residues that ultimately target it for degradation by the 26S proteasome, leaving NF κ B free to dimerize and activate transcription (Jaffray et al., 1995; Kroll et al., 1997). Recent results have shown that I κ B α can also be modified by SUMO-1 at Lys21, the primary site of ubiquitination. SUMO-1 modification does not require phosphorylation of I κ B. In fact, the serine phosphorylation of I κ B required for ubiquitination appears to inhibit SUMO-1 modification (Desterro et al., 1998). SUMO-1 modified I κ B is resistant to TNF α signaling and degradation. Furthermore, overexpression of Ubc9 or SUMO-1 results in reduced TNF α signaling through NF κ B. Thus, SUMO-1 appears to create a pool of stabilized I κ B/NF κ B that is resistant to signaling and protease degradation of I κ B (Desterro et al., 1998; Kretz-Remy and Tanguay, 1999). Like NF κ B, p53 is a transcription factor. P53 is unique, however, in that it has tumor suppressive properties and is integrally tied to programmed cell death. Normally p53 is made in all cells but is rapidly ubiquitinated and degraded. When cells are stressed, p53 ceases to be ubiquitinated and is, therefore, stabilized, and p53 accumulates and activates transcription. Recent studies have shown that p53 is also capable of being SUMO-1 modified (Gostissa et al., 1999; Rodriguez et al., 1999). P53 is SUMO-1 modified at Lys386. Mutations in this residue do not affect the level of ubiquitination of p53. Modification of p53 by SUMO-1 leads to increased levels of p53 transcriptional activity. Thus SUMO-1 may function to activate or enhance p53's transactivating activity (Gostissa et al., 1999; Rodriguez et al., 1999).

SUMO-1 modification of PML, Sp100, and HIPK-2 causes localization to nuclear bodies, discrete subdomains within the nucleus. The protein PML was originally identified through its association with acute promyelocytic leukemia, which in 70-100% of cases is caused by a translocation event that creates a fusion protein of PML and the retinoic acid receptor- α (RAR- α). The normal PML, but not the PML-RAR- α fusion protein is modified by SUMO-1 (Duprez et al., 1999; Kamitani et al., 1998b; Kamitani et al., 1998c; Muller et al., 1998). PML is normally found in nuclear bodies or ND10, interchromosomal accumulations of protein. Experiments have demonstrated that SUMO-1 modification of PML is required for its association into ND10 (Duprez et al., 1999; Kamitani et al., 1998b; Kamitani et al., 1998c; Muller et al., 1998). A number of the other ND10 proteins have been identified and include Daxx, BML, RecQ helicase, and Sp100 (Everett et al., 1999a; Ishov et al., 1999). The ND10 component Sp100 is also SUMO-1 modified, and SUMO-1 modification is required for Sp100 localization to ND10 (Sternsdorf et al., 1999). Interestingly, PML plays a critical role in ND10 formation, as cells that lack PML or have a mutant form of PML that cannot be SUMO-1 modified do not form ND10 and the other ND10 proteins localize elsewhere (Ishov et al., 1999). Thus PML and its SUMO-1 modification are critical for ND10 formation.

Unlike most SUMO-1 modified proteins, PML shows evidence of incrementally larger products suggesting that PML might be poly-SUMO-1 modified. Experiments demonstrated, however, that PML is modified by SUMO-1 at three distinct sites, which explains the appearance of multiple SUMO-1 modified species of PML (Kamitani et al., 1998b). ND10 formation and both PML and Sp100 SUMO-1 modification appear to be cell cycle regulated (Everett et al., 1999b). During interphase, both PML and Sp100 are

SUMO-1 modified and tightly colocalize to ND10. However, during mitosis PML and Sp100 cease to form ND10 and are no longer SUMO-1 modified. Also, during mitotic phase a labile, alternatively modified form of PML appears that is stabilized by the phosphatase inhibitor calyculin A (Everett et al., 1999b). Furthermore, treatment of interphase cell extracts with calyculin A results in the formation of a PML species with similar gel mobility as the mitotic phase PML species, suggesting that phosphorylation may play a role in PML SUMO-1 modification (Everett et al., 1999b).

HIPK2, homeodomain interacting protein kinase 2, is a member of a recently identified family of nuclear kinases which act as corepressors of homeodomain transcription factors. HIPK2 is modified at its very carboxy-terminus on lys1182 at a site that does not match the consensus SUMO-1 modification sequence ([V/I/L]KX [E/D]) (Kim et al., 1999). Ubc9 interacts with HIPK2 between amino acids 860 and 892. Thus, HIPK2 has a Ubc9 interaction domain that is discrete from its SUMO-1 modification site. HIPK2 localizes to discrete nuclear domains. Both the Ubc9 interaction domain and the SUMO-1 modification site are required for nuclear domain formation. Curiously SUMO-1 modified HIPK2 does not co-localize with PML suggesting that the HIPK2 nuclear dots represent nuclear domains distinct from ND10 (Kim et al., 1999).

In the yeast *S. cerevisiae*, four proteins known as septins have been shown to be Smt3 modified. Septins are proteins that are part of the 10 nm fibers that encircle the bud neck during mitosis. In *S. cerevisiae* Smt3 is essential for entry into mitosis (Li and Hochstrasser, 1999). Smt3 conjugated septins appear just before the onset of anaphase and abruptly disappear during cytokinesis (Johnson and Blobel, 1999). Curiously, only the septins on the maternal side of the bud neck are Smt3 modified. Smt3 modification

sites in all four septins have been identified and all conform to the SUMO-1 consensus sequence. Mutation of these Smt3 sites eliminates almost all the Smt3 staining at the bud neck and results in a phenotype of defective septin ring disassembly (Johnson and Blobel, 1999). Thus SUMO-1 may play a role in the dynamics of the septin ring in *S. cerevisiae*.

Previous work has shown HSF1 is posttranslationally modified by phosphorylation. A great deal of work has gone into characterizing the nature and function of both the basal and activation induced phosphorylation of HSF1 (Chu et al., 1996; Cotto et al., 1996; Farkas et al., 1998; Hoj and Jakobsen, 1994; Kim et al., 1997; Kline and Morimoto, 1997; Knauf et al., 1996; Mivechi and Giaccia, 1995; Xia et al., 1998; Xia and Voellmy, 1997). In contrast, very little is known about posttranslational modification of HSF2. Preliminary studies demonstrated that HSF2 did not have the western blot mobility changes caused by phosphorylation as seen for HSF1 (Sarge et al., 1993). HSF2 is known to have a relatively short half-life of 60-70 min, and drugs that inhibit 26S proteasome function such as MG132 and lactacystin lead to the accumulation and subsequent activation of HSF2. Interestingly, HSF2 does not appear to be ubiquitin modified (Mathew et al., 1998).

Results from this work indicate that HSF2, but not HSF1 is modified by the covalent attachment of SUMO-1. HSF2, but not HSF1, is a substrate for SUMO-1 modification in an *in vitro* conjugation assay. Consistent with these findings, HSF2 but not HSF1 appears to interact with a portion of Ubc9, the SUMO-1 conjugating enzyme, in yeast two hybrid assay. The fusion protein GFP-HSF2 colocalizes with SUMO-1 in nuclear domain structures in approximately 7% of transfected HeLa cells. These data

would suggest that the function of SUMO-1 modification is to localize HSF2 to nuclear bodies in a regulated manner.

MATERIALS AND METHODS

Plasmid DNA Construction

The yeast two hybrid vectors pGBD-HSF1 and pGBD-HSF2 were cloned as previously described (Hong and Sarge, 1999). Polymerase chain reaction (PCR) was used to generate BclI sites immediately before and after the open reading frame of the mouse HSF2 β cDNA. The BclI digested PCR fragment of HSF2 β was cloned into the BamHI site of pQE9 (Qiagen, Hilden, Germany), thus generating pQE9-HSF2 β . The pGEX-SUMO-1 plasmid was cloned as previously described, and was a generous gift of Dr. Joanna Desterro (Desterro et al., 1997).

PCR was used to generate a Sall site and a Kozak consensus sequence (5'-CCACC-3') immediately before and a ClaI site immediately after the open reading frame of the mouse HSF2 β cDNA (Kozak, 1987). This undigested PCR fragment of HSF2 β was cloned into the SmaI site of the pGEM-7Z (Promega, Madison, WI) cloning vector in which the ClaI site had been destroyed, thus generating the plasmid pGEM-HSF2 β SC. PCR was also used to add an XhoI site and a Kozak consensus sequence before and a HindIII site, a stop codon, and then a KpnI site immediately before the naturally occurring stop codon of the open reading frame of mouse HSF1 β cDNA. The XhoI and KpnI digested PCR fragment of HSF1 β was cloned into pSP72 (Promega, Madison, WI)

cloning vector digested with the same restriction endonucleases to generate the plasmid pSP-HSF1 β -XHK.

The plasmid pcDNA-HSF2 β -MH₆ was cloned by digesting pGEM-HSF2 β SC with Sall and HindIII to liberate the majority of the HSF2 ORF, and cloning it into pcDNA3.1/MycHisA(-) (Invitrogen, Carlsbad, CA) digested with XhoI and HindIII. The remaining portion of the HSF2 β open reading frame was cloned by PCR using primers which spanned the endogenous HindIII site in HSF2 and added a HindIII site immediately 5' to the endogenous stop codon. The HindIII digested PCR fragment was cloned into the HindIII site of the previous construct and orientation of the insert was verified using PCR. The insert for pEGFP-HSF2 β was generated by digesting pGEM-HSF2 β SC with ClaI, filling the resulting ends in with Klenow DNA polymerase (New England Biolabs, Beverly, MA), and digesting with Sall. The insert was then cloned into pEGFP-C1 (Clontec, Palo Alto, CA) digested with Sall and SmaI to create pEGFP-HSF2 β . pEGFP-HSF1 β was cloned by digesting pSP-HSF1 β -XHK with XhoI and KpnI and cloning it into pEGFP-C1 digested with XhoI and KpnI as well.

SUMO-1 Consensus Site Pattern Matching

The SUMO-1 consensus sites were identified in the HSF2 predicted protein sequence using the PATTERNMATCH algorithm in the Biology Workbench 3.2 program suite. Biology Workbench is a internet based suite of sequence analysis tools developed by the National Center for Supercomputing Applications at the University of Illinois and maintained by the San Diego Supercomputer Center

(<http://workbench.sdsc.edu/>). The mouse HSF2 α protein sequence was analyzed for the expression [ILV]K. [ED], which searches for either an isoleucine, a leucine, or a valine in the first position followed by a lysine, any amino acid, and then a glutamate or an aspartate in last position (Johnson and Blobel, 1999).

Site Directed Mutagenesis of HSF2.

Point mutants were generated in pcDNA-HSF2 β -MH₆ which change the three predicted SUMO-1 modified lysine residues to arginine. The predicted residues are Lys 82, Lys 139, and Lys 151. Site directed mutagenesis was performed using the QuickChange mutagenesis kit (Stratagene, La Jolla, CA) according the manufacture's protocol, using the following mutagenic oligonucleotides: HSF2K82R-top, GGAAT TATCA GACAG GAAAG AGATG G; HSF2K82R-btm, CCATC TCTTT CCTGT CTGAT AATTC C; HSF2K139R-top, GGTTC AAATA AGACA AGAAA CTATT GAG; HSF2K139R-btm, CTCAA TAGTT TCTTG TCTTATTTGA ACC; HSF2K151R-top, GCTTT CAGAA TTAAG AAGTG AGAAT GAATC C; HSF2K151R-btm, GGATT CATTC TCACT TCTTA ATTCT GAAAG C. The K82R mutant oligonucleotides were also used to make the K82R mutant in pGBD-HSF2 and pEGFP-HSF2 β . Mutants were confirmed by DNA sequencing.

Yeast Transformation and the Two-Hybrid Assay.

A 100 ml culture of YPD medium (20 g/l Bacto peptone (Difco Laboratories, Livonia, MI), 10 g/l yeast extract (Difco Laboratories, Livonia, MI), 20g/l dextrose, pH 5.8) was inoculated with the *S. cerevisiae* strain PJ 69-4A (*MATa trp 1-901 leu2-3,112 ura3-52 ade2-101 his3-200 gal4Dgal80DLYS2::GAL1-HIS3 GAL2-ADE2 met2::GAL7-lacZ*) and grown at 30°C with agitation until culture reached OD₆₀₀ = 1.0 (James et al., 1996). The yeast were harvested by centrifugation for 5 min at 5,000 x g (5,500 rpm in a GSA rotor). The supernatant medium was discarded, and the yeast were washed twice in 10 ml TE, pH 7.0 (10 mM Tris-HCl, pH 7.0 + 1 mM EDTA). The yeast were resuspend in 1 ml of 100 mM LiOAC•TE (100 mM lithium acetate, 10 mM Tris-HCl, pH 7.0 + 1 mM EDTA) and were incubate at 30°C for 1 hr. Cells were then distributed into 100 µl aliquots. Aliquots were either used immediately or 50 µl of 50% glycerol was added to each aliquot, and the yeast were stored at -80°C for future transformations. Yeast were transformed with 5 µg of each plasmid DNA and 50 µg of sheared salmon sperm DNA (Sigma, St. Louis, MO). The yeast were gently vortexed and incubated at 30°C for 30 min. Four volumes of 40% PEG4000•LiOAC (40% polyethylene glycol (average molecular weight 3,350 Da—Sigma, St. Louis, MO), 100 mM lithium acetate, 10 mM Tris-HCl, pH 7.0 + 1 mM EDTA) was added, and the yeast were gently vortexed and incubated at 30°C for 1 hr. The sample was heat shocked for 5 min at 42°C, and the yeast were harvested by centrifugation at 6,000 rpm for 1 min. The supernatant was discarded and the yeast were washed with 1 ml of the appropriate yeast minimal selective medium (1.7 g/l yeast nitrogen base without amino acids or ammonium sulfate (Difco Laboratories, Livonia, MI), 5 g/l ammonium sulfate, and 20 g/l dextrose) containing the appropriate nutrient supplementation to complement the auxotrophies of PJ69-4A

(typically adenosine, histidine, uracil, and methionine at a concentration of 20 mg/l each), but lacking the nutrients complemented by the two plasmids of interest (typically leucine and tryptophan). The yeast were resuspended in 200 μ l of the appropriate yeast minimal selective medium and grown on plates containing the same minimal selective medium (with 20g/l Bacto Agar (Difco Laboratories, Livonia, MI)) at 30°C for 2-3 days. Colonies were transferred onto plates that contained the yeast minimal selective medium and also onto plates that also lacked adenosine or histidine, which is complemented by the two-hybrid assay reporter gene. Yeast were again grown 3 days at 30°C. Growth on the reporter gene selective plates was interpreted to indicate an interaction between the two proteins that were expressed from the yeast plasmids.

***In vitro* SUMO-1 Modification Assay**

All *in vitro* SUMO-1 modifications were done by Dr. Michael J. Matunis as previously described (Lee et al., 1998).

Recombinant Protein Expression

The bacterial expression plasmid pQE9-HSF2 β or pGEX-SUMO1 were transformed into the *E. coli* strain BL21 (F⁻ ompT hsdS_B (r_B⁻ m_B⁻) gal dcm—Novagen, Madison, WI) which had been previously transformed with the pREP4 plasmid (Qiagen, Hilden, Germany) and plated onto LB+Glc plates (10 g/l Bacto tryptone (Difco Laboratories, Livonia, MI), 5 g/l yeast extract (Difco Laboratories, Livonia, MI), 4 g/l

dextrose, pH 7.0) containing 100 µg/ml ampicillin and 25 µg/ml kanamycin. Bacteria were grown overnight at 37°C. Five colonies were picked from the fresh transformation plate and pooled for growth overnight at 37°C with vigorous (>400 rpm) shaking in 5 ml LB+Glc containing 200 µg/ml ampicillin and 25 µg/ml kanamycin. The overnight culture was harvested and resuspended in 250 ml fresh LB+Glc containing 200 µg/ml ampicillin and 25 µg/ml kanamycin. The culture was grown at 37°C with vigorous shaking to OD₅₉₅ = 0.6-1.0. The bacteria were harvested and washed once in 30-40 ml M-9 with lactose medium (48 mM Na₂HPO₄, 22 mM KH₂PO₄, 86 mM g/l NaCl, 187 mM NH₄Cl, 100 µM CaCl₂, 1mM MgSO₄, 4 g/l D-lactose, 4 g/l casamino acids (Difco Laboratories, Livonia, MI), 1 mg/l thiamin, 100 µg/ml ampicillin, and 0.5 mM isopropyl-β-D-thiogalactopyranoside). The bacteria were resuspended in 1 l of M-9 with lactose medium and grown for 3 hr at 37°C with vigorous shaking to induce protein expression. Bacteria were harvested by centrifugation and resuspended in 30 ml PBS. The bacteria were then pelleted and the supernatant was discarded. Bacterial pellets were rapidly frozen in a dry ice/ethanol bath and stored at -80°C until needed for protein purification.

Recombinant Protein Purification

Recombinant His₆ affinity tagged HSF2 was purified from bacteria containing pQE9-HSF2β. The bacterial pellet was resuspended in pQE Wash buffer (100 mM KCl, 20 mM Tris-HCl, pH 7.9, 2 mM 2-mercaptoethanol, and 5 mM imidazole). Lysozyme was added to a final concentration of 100 µg/ml, and the bacteria were incubated for 15 min at room temperature before returning to ice. The bacteria were lysed by sonication

with three 15 s pulses with a W-220 Sonicator (Mysonix, Farmingdale, NY) with a ½ inch horn at 70% output (~150 W) with cooling on ice for 1 min between pulses.

Sarkosyl was added to 1% (w/v) final concentration and the lysate was cleared by centrifugation at 12,000 x g for 15 min at 4°C. The supernatant was applied to a 3 ml Ni/NTA resin column (Qiagen, Hilden, Germany) at a flow rate of 0.5 ml/min. The column was washed in pQE wash buffer at a flow rate of 1.5 ml/min until the column effluent absorbance returned to baseline (measured using an inline 280 nm UV spectrophotometric detector on a Pharmacia GradiFrac low pressure liquid chromatography system). The His₆-HSF2 was eluted with an imidazole gradient of 5 mM to 400 mM. The HSF2 protein eluted at 150-200 mM imidazole concentration.

Recombinant glutathione-S-transferase (GST) affinity tagged SUMO-1 was purified from bacteria containing pGEX-SUMO1. Protein expression was induced as described in the previous section. The bacterial pellet was resuspended in SUMO lysis buffer (50 mM Tris-HCl, pH 7.5, 500 mM NaCl, 1mM dithiothreitol). Lysozyme was added to a final concentration of 100 µg/ml, and the bacteria were incubated for 15 min at room temperature before returning to ice. The bacteria were lysed by sonication with three 15 s pulses with a W-220 Sonicator (Mysonix, Farmingdale, NY) with a ½ inch horn at 70% output (~150 W) with cooling on ice for 1 min between pulses. Triton X-100 was added to 1% (w/v) final concentration and the lysate was cleared by centrifugation at 12,000 x g for 15 min at 4°C. The supernatant was applied to 750 µl of a 50% slurry of glutathione agarose resin (Sigma, St. Louis, MO) in SUMO lysis buffer. The slurry was incubated at 4°C for 20 min with constant inversion mixing. The resin was collected by centrifugation and the supernatant was discarded. The resin was washed

five times with 1 ml SUMO lysis buffer. The protein was eluted twice by incubation with 250 μ l SUMO lysis buffer with 10 mM glutathione for 2 min. It is necessary to adjust the pH to 7-7.5 with NaOH before using the elution buffer, as glutathione is supplied as a free acid and dramatically lowers the pH of the buffer (to around pH 3). The eluates were pooled. More than 50% of the SUMO-1 remained bound to the resin. Incubation with elution buffer for more than 2 hr resulted in the elution of the majority of the bound SUMO-1.

Both His₆-HSF2 and GST-SUMO-1 were dialyzed into a buffer containing 20 mM Tris, pH 7.5, 100 mM KCl, 2 mM 2-mercaptoethanol, and 10% glycerol. The concentration of the protein was determined using the BioRad Protein Assay Kit (BioRad, Hercules, CA). All measurements were normalized to a BSA standard concentration curve. The proteins were aliquotted and rapidly frozen in a dry ice/ethanol bath before storing at -80°C until needed.

Transient Transfection of HeLa Cells

HeLa cells were transfected with pEGFP-C1, pEGFP-HSF1 β , or pEGFP-HSF2 β independently using Lipofectamine 2000 (Life Technologies, Rockville, MD). In brief, HeLa cells were seeded in a six-well tissue plate with a sterile nitric acid washed 22mm x 22mm cover slip, such that the cells would be approximately 80% confluent by the following morning. HeLa cells were grown in DMEM containing 10% fetal bovine serum (FBS) and 50 $\mu\text{g/ml}$ gentamicin (Life Technologies, Rockville, MD) at 37°C with 5% CO_2 . For each transfection, 4 μg of DNA was mixed with 250 μl of DMEM without

FBS or antibiotics in one well of a 24 well tissue culture dish. In a second well, 7.5 μ l of Lipofectamine 2000 was mixed with 250 μ l of DMEM and incubated for 3 min at room temperature. The two mixtures were then combined and allowed to incubate for 20 min at room temperature. The medium was removed from the HeLa cells. The HeLa cells were washed once with 2.5 ml of DMEM without FBS or antibiotics and 500 μ l of DMEM without FBS or antibiotics was added to cells. The DNA/Lipofectamine mixture was then added to the HeLa cells and incubated for 6 hr at 37°C with 5% CO₂. After six hours, the DNA containing DMEM was removed and the media was replaced with 3 ml DMEM containing 10% FBS and 50 μ g/ml gentamicin. HeLa cells were grown for 24 hr before analyzing by fluorescence microscopy.

Immunofluorescent Microscopy

HeLa cells were plated on 22x22mm nitric acid washed coverslips in 6 well dishes 24h before transfecting or doing microscopy. The coverslips were removed from 6 well dish and fixed with cold (-80°C) MeOH for 6 min. The SUMO-1 primary monoclonal antibody 21C7 or the antibody and 250 μ g of purified pGEX-SUMO1 protein for the preadsorbed control was diluted 1:1000 in phosphate buffered saline (PBS) [137 mM NaCl, 2.7 mM KCl, 8 mM Na₂HPO₄, 1.5 mM KH₂PO₄] +2% bovine serum albumin (BSA—Fraction V, Sigma, St. Louis, MO). The antibody dilutions were incubated 20 min on ice and centrifuged for 10 min at 12,000 rpm at room temperature. The supernatant of the antibody dilutions was retained. The coverslips were removed from the MeOH and cells were rehydrated for 30s in PBS. The coverslips were washed three

times in PBS and 3 times in PBS+2%BSA. The coverslips were incubated with the antibody dilution or the preadsorbed antibody for 20 min at room temperature. The coverslips were washed three times with PBS+2%BSA. The coverslips were incubated 20 min with a 1:200 dilution of a horse anti mouse IgG antibody conjugated to the Texas Red fluorochrome (Vector Labs, Burlingame, CA). The coverslips were then washed three times PBS+2%BSA and three times with PBS. The coverslips were incubated 5 min with 50 ng/ml 4',6-diamidino-2-phenylindole (DAPI). Coverslips were washed three times briefly in distilled water and the excess moisture was removed. Coverslips were mounted on a slide with Vectashield (Vector Labs, Burlingame, CA) mounting medium and sealed using blue fingernail polish. Immunostaining was visualized using a Nikon fluorescent microscope with a 60x objective and a Nikon Spotcam digital-imaging camera.

RESULTS

Two Hybrid Analysis of the HSF2/Ubc9 interaction

The yeast two-hybrid system, developed by Fields and Song in 1989, is a sensitive method for identifying protein-protein interactions. This system can be used to demonstrate interactions between known proteins or for identifying unknown factors that interact with a given protein (Fields and Song, 1989). The yeast two hybrid system relies on the observation that eukaryotic transcription factors are often modular. The DNA binding domain is separate from the transactivation domain in many transcription factors

including the yeast GAL4 transcription factor. Protein-protein interactions can be demonstrated by creating a fusion protein of one protein to the activation domain (the target) and a fusion protein of another protein to the DNA binding domain (the bait) (Figure 3.3). By transforming these constructs into a yeast cell which contain a reporter gene under the control of the appropriate promoter element (as dictated by the DNA binding domain), interactions can be demonstrated by the activity of the reporter gene. If the proteins of interest interact, the activation and DNA binding domain will be held in close enough proximity by the protein-protein interactions to activate transcription of the reporter gene. If the proteins fail to interact, the reporter gene will remain silent, because the activation domain will not be in the proximity of the DNA binding domain (Reviewed in (Bartel et al., 1993; Bartel and Fields, 1995; Fields and Sternglanz, 1994; Mendelsohn and Brent, 1994)).

Figure 3.3: Schematic diagram of the yeast two hybrid assay.

Plasmids that express a “bait” protein (HSF2) fused to a DNA binding domain and a “target” protein (Ubc9) fused to a transcriptional activation domain are transformed into a yeast strain with a reporter gene (typically a gene to complement an amino acid auxotrophy) under the control of a promoter containing a binding element for the bait plasmid DNA binding domain. If the bait and target proteins interact, the activation domain and DNA binding domain are held in close proximity, and transcription of the reporter gene is activated, allowing the yeast to grow on medium lacking the amino acid produced by the reporter gene. If the bait and target proteins do not interact, the activation and DNA binding domains are not tethered and cannot activate transcription of the reporter gene. The reporter gene remains silent and the yeast are unable to grow on reporter gene selective medium.

Figure 3.3: Schematic diagram of the yeast two hybrid assay.

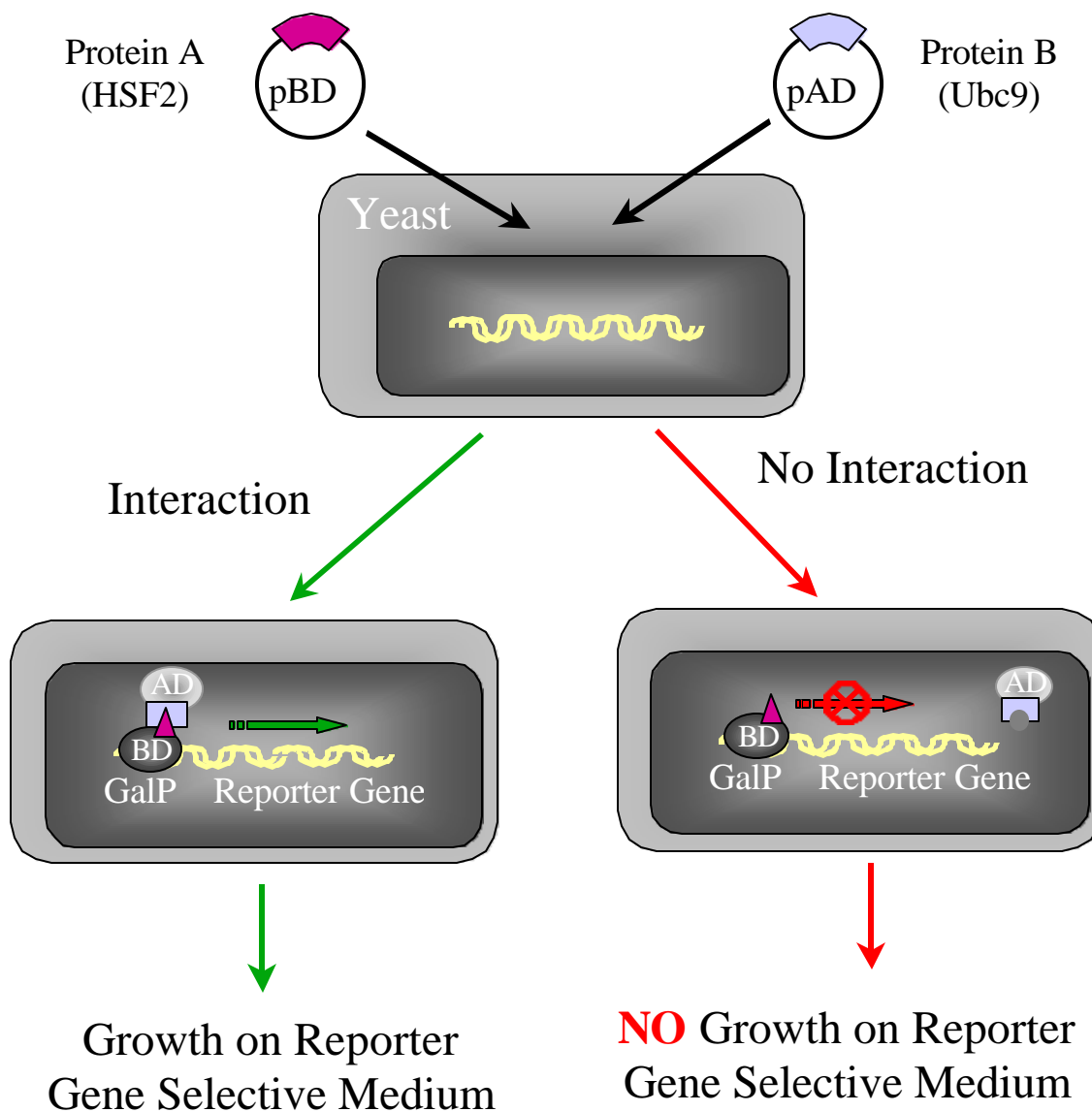

Initially Fields and Song used the yeast two-hybrid system to demonstrate the interaction between SNF1, a kinase, and SNF4, an SNF1 associated protein (Fields and Song, 1989). Later this technique was used to identify unknown proteins that interact with a given protein by screening a cDNA library in which the cDNA clones were fused to an activation domain (Chien et al., 1991). This library screening technique was how a large portion of Ubc9 (a region corresponding to amino acids 4-128 of Ubc9's 160 amino acids) was identified as a rat estrogen receptor- β (ER- β) (In, Y., data not shown). Serendipitously (and erroneously) HSF2 was used a negative control for interaction with Ubc9. To demonstrate that HSF2 interacted with Ubc9 specifically, we tested whether the partial Ubc9 protein (pVP16 Δ Ubc9) could interact with HSF1 (pGBD-HSF1) or the Gal4 DNA binding domain alone (pGBD-C2) as well as with HSF2 (pGBD-HSF2) (Figure 3.4). Ubc9 interacts with HSF2 and perhaps only weakly with HSF1 in the yeast two-hybrid assay. The interaction with HSF1 must be considered suspect because pGBD-HSF1 has demonstrated a certain inherent transcriptional activity which manifests itself as very weak growth under selective conditions without an appropriate activation domain partner. Ubc9 is not capable of interacting with the Gal4 DNA binding domain alone, suggesting that Ubc9 does interact with HSF2 specifically.

***In vitro* SUMO-1 modification of HSF2.**

All SUMO-1 modified proteins identified to date have also interacted with Ubc9. This observation prompted us speculate that HSF2 might be SUMO-1 modified. To this end, *in vitro* transcribed and translated HSF2 was used as a substrate in an *in vitro* SUMO-1

modification assay. HSF2 was transcribed from a full-length cDNA (including untranslated regions) of the mouse HSF2- β gene (called c9) (Sarge et al., 1991). The *in vitro* transcribed mRNA was translated in the presence of ^{35}S -methionine to produce radiolabeled HSF2 protein. The *in vitro* SUMO-1 modification system contains purified recombinant SUMO-1 and Ubc9, a HeLa cell extract, which contains the SUMO activating enzyme activity of the SAE1/2 heterodimer, ATP, and an ATP regenerating system. When the HSF2 protein is incubated with the HeLa extracts alone, a faint higher molecular weight protein corresponding in size to the SUMO-1 modified form of HSF2 appears (Figure 3.5). This is presumably due to small amounts of endogenous SUMO-1 and Ubc9 in the HeLa extracts. When either SUMO-1 or Ubc9 are omitted from the reaction only the faint SUMO-1 modified HSF2 product is observed. Interestingly the abundance of this product decreases when only Ubc9 is added to the reaction mix, presumably due to competition for the endogenous SUMO-1. When SUMO-1 and Ubc9 are added to the reaction mixture, a substantial increase in the higher molecular weight product is observed, corresponding to SUMO-1 modified HSF2 (Figure 3.5). Interestingly HSF2 also appears to be a substrate for SUMO-2 modification as well as SUMO-1 modification. In contrast, HSF1 does not appear to be a substrate for SUMO-1 modification (Figure 3.6). When *in vitro* translated HSF1 is incubated in the presence of the HeLa cell lysate, several higher molecular weight products are observed. However, when Ubc9 or SUMO-1 or both are added to the reaction, the abundance or mobility of these is not affected. HSF1, therefore, does not appear to be a substrate for SUMO-1 modification *in vitro*. The higher molecular weight products observed in the presence of

the HeLa cell lysates are most likely hyperphosphorylation states commonly observed with HSF1 (Sarge et al., 1993).

Nuclear colocalization of SUMO-1 and GFP-HSF2.

One functional consequence of SUMO-1 modification often observed is localization to discrete nuclear domain structures. This appears to be the case for the SUMO-1 modified forms of HIPK2, PML, and Sp100 (Kretz-Remy and Tanguay, 1999). We were interested in determining if HSF2 was localized to nuclear domain structures with SUMO-1. Initial attempts to use a rabbit polyclonal antiserum for colocalization experiments were unsuccessful due to high nonspecific background staining (data not shown). To solve this problem, plasmids for expressing a fusion protein of the jellyfish *Aequorea victoria* green fluorescent protein (GFP) and either HSF1- β or HSF2- β were developed. The human cervical carcinoma cell line HeLa was transfected with pEGFP-HSF2 β and then fixed and stained with a monoclonal antibody against SUMO-1 (21C7) as well as DAPI for visualization of the nucleus (Figure 3.7). Only a few of the cells that were transfected with pEGFP-HSF2 β had the punctate nuclear GFP-HSF2 staining observed with nuclear bodies. The majority of the cells had cytosolic staining in which GFP-HSF2 was excluded from the nucleus. Of those cells that did contain GFP-HSF2 nuclear domain staining, the HSF2 nuclear domain structures did colocalize with SUMO-1.

To verify that the punctate nuclear staining was specific to HSF2, HeLa cells were transfected with pEGFP-C1 (the parental GFP expression vector), pEGFP-HSF1 β , or

pEGFP-HSF2 β . The staining pattern observed for GFP-HSF2 is distinct from either GFP-HSF1 or GFP alone (Figure 3.8). GFP is expressed throughout the cytosol and the nucleus, whereas GFP-HSF1 is localized almost entirely within the nucleus. Neither GFP nor GFP-HSF1 display the punctate nuclear staining or the predominantly cytosolic staining patterns observed with HSF2.

In order to establish that the protein staining by the SUMO-1 antibody was specific for SUMO-1, purified His₆-HSF2 β and GST-SUMO-1 were purified (Figure 3.9). The purified SUMO-1 antibody was preincubated with 2% BSA or 2% BSA containing 250 μ g of purified GST-SUMO-1 prior to staining pEGFP-HSF2 β transfected HeLa cells. Preadsorbing the SUMO-1 antibody with SUMO-1 prior to staining completely abolished the nuclear domain structure staining normally observed with SUMO-1 (Figure 3.10). Preadsorbing the antibody with 250 μ g of His₆HSF2 protein had no effect on SUMO-1 antibody staining (data not shown).

Preliminary efforts at coimmunoprecipitating SUMO-1 with HSF2 were not successful. In fact, observing an HSF2 immunoreactive species of the appropriate size for SUMO-1 modified HSF2 was not possible either (data not shown). This is presumably due to the small percentage of cells that contain SUMO-1 modified HSF2 and the small portion of HSF2 within those cells that is SUMO-1 modified. We suspected that SUMO-1 modification of HSF2 might be cell cycle regulated. To test this, we stained cells with the nonvital DNA stain Hoescht 33342 (bisbenzimidazole) and the calcium channel inhibitor Verapamil (to prevent the rapid efflux of the Hoescht stain from the cells), and sorted them according to cell cycle stage using a fluorescent-activated cell sorter (FACS) (Krishan, 1987). These sorted cells were used for HSF2

immunoblot analysis and for HSF2 immunoprecipitation followed by SUMO-1 immunoblot analysis (data not shown). Neither of these analyses was successful in detecting a SUMO-1 modified HSF2 product. These results do not necessarily indicate that SUMO-1 modification of HSF2 is not cell cycle regulated. If SUMO-1 modification of HSF2 is adversely affected by the drug Verapamil or only occurs in a small portion of the cells in one of the sorted populations, immunoblot analysis may still fail to detect the SUMO-1 modified HSF2 product.

As only a few cells seemed to contain punctate GFP-HSF2 nuclear staining, we were interested in quantifying the percentage of cells the HSF2 nuclear domain staining. The results from two experiments are shown in Table 1.

Table 1. Quantification of GFP-HSF2 nuclear domain staining

GFP-HSF2 Pos. Cells	Nuclear Dots	% Nuclear Dots
422	27	6.4 %
412	30	7.3 %

Cells that were positive for GFP-HSF2 staining were simultaneously counted with GFP-HSF2 positive cells that contained punctate nuclear staining (Nuclear Dots).

These data indicate that only 6.8% (± 0.4) of the GFP-HSF2 positive HeLa cells contain punctate nuclear domain structures.

Identification of the SUMO-1 modification site in HSF2.

We were interested in determining which amino acid residue or residues were modified by SUMO-1 in HSF2. The mouse HSF2- α protein contains 36 lysine residues—too many to mutate and analyze individually (Sarge et al., 1991). However, of the SUMO-1 modified proteins described to date, all but HIPK2 conform to a consensus modification site of isoleucine, leucine, or valine followed by the SUMO-1 modified lysine, any amino acid and finally a glutamate or aspartate residue (Johnson and Blobel, 1999). We analyzed the mouse HSF2- α sequence to determine if there were consensus SUMO-1 modification sites. This analysis was done using the PATTERNMATCH algorithm from the Biology Workbench 3.2 suite of sequence analysis tools. HSF2 contains three SUMO-1 consensus modification sites at lys82, lys139, and lys151 (Figure 3.11) (Sarge et al., 1991).

Mutations were made in pcDNA-HSF2 β -MH₆ that changed each of these lysine residues to arginine—K82R, K139R, and K151R. The plasmid pcDNA-HSF2 β -MH₆ was chosen because in addition to being an epitope tagged mammalian expression vector, which could be useful in future research, it contains a T7 RNA polymerase promoter suitable for *in vitro* transcription and translation. All three mutations and the wild type pcDNA-HSF2 β -MH₆ were used as substrates for *in vitro* SUMO-1 modification reactions (Figure 3.12). The results of this clearly indicate that lysine 82 is the primary site of SUMO-1 modification on HSF2. The consensus SUMO-1 modification site found at Lys82 in the mouse HSF2 is conserved in the chicken and human homologs HSF2, suggesting that SUMO-1 modification of HSF2 may be conserved among vertebrates (Schuetz et al., 1991).

Figure 3.4: Two-hybrid analysis of the HSF2/Ubc9 interaction.

Ubc9 interacts with HSF2 (pGBD-HSF2+pVP16 Δ Ubc9) and only weakly with HSF1 (pGBD-HSF2+pVP16 Δ Ubc9). HSF1 and HSF2 do not interact with the VP16 activation domain alone (pGBD-HSF1+pVP16 and pGBD-HSF2+pVP16), and Ubc9 does not interact with the Gal4 DNA binding domain alone (pGBD-C2+ pVP16 Δ Ubc9). PR65 is a positive control that is known to interact with HSF2 (pGBD-HSF2 + pGAD-PR65). Medium lacking tryptophan (-trp) and leucine (-leu) selects for both plasmids. Media lacking adenosine (-ade) or histidine (-his) are selective for two reporter genes in the *S. cerevisiae* strain PJ69-4A.

Figure 3.4: Two-hybrid analysis of the HSF2/Ubc9 interaction.

Figure 3.5: *In vitro* SUMO-1 and SUMO-2 modification of HSF2.

HSF2 is a substrate for both SUMO-1 and SUMO-2 modification. Modification requires the addition of HeLa cytosol (SUMO activating enzyme activity), Ubc9, and SUMO-1 or SUMO-2. Omission of any of these results in a dramatic diminution of the abundance of SUMO modified HSF2 (dark triangle). The unmodified HSF2 is indicated by the light triangle. *In vitro* modification reactions containing ^{35}S -labeled HSF2 are analyzed by SDS-PAGE and visualized by autoradiography. *In vitro* SUMO-1 modification assay performed by Dr. Michael J. Matunis.

Figure 3.5: *In vitro* SUMO-1 and SUMO-2 modification of HSF2.

In vitro SUMO-1 modification of
in vitro transcribed and translated HSF2 cDNA (C9)

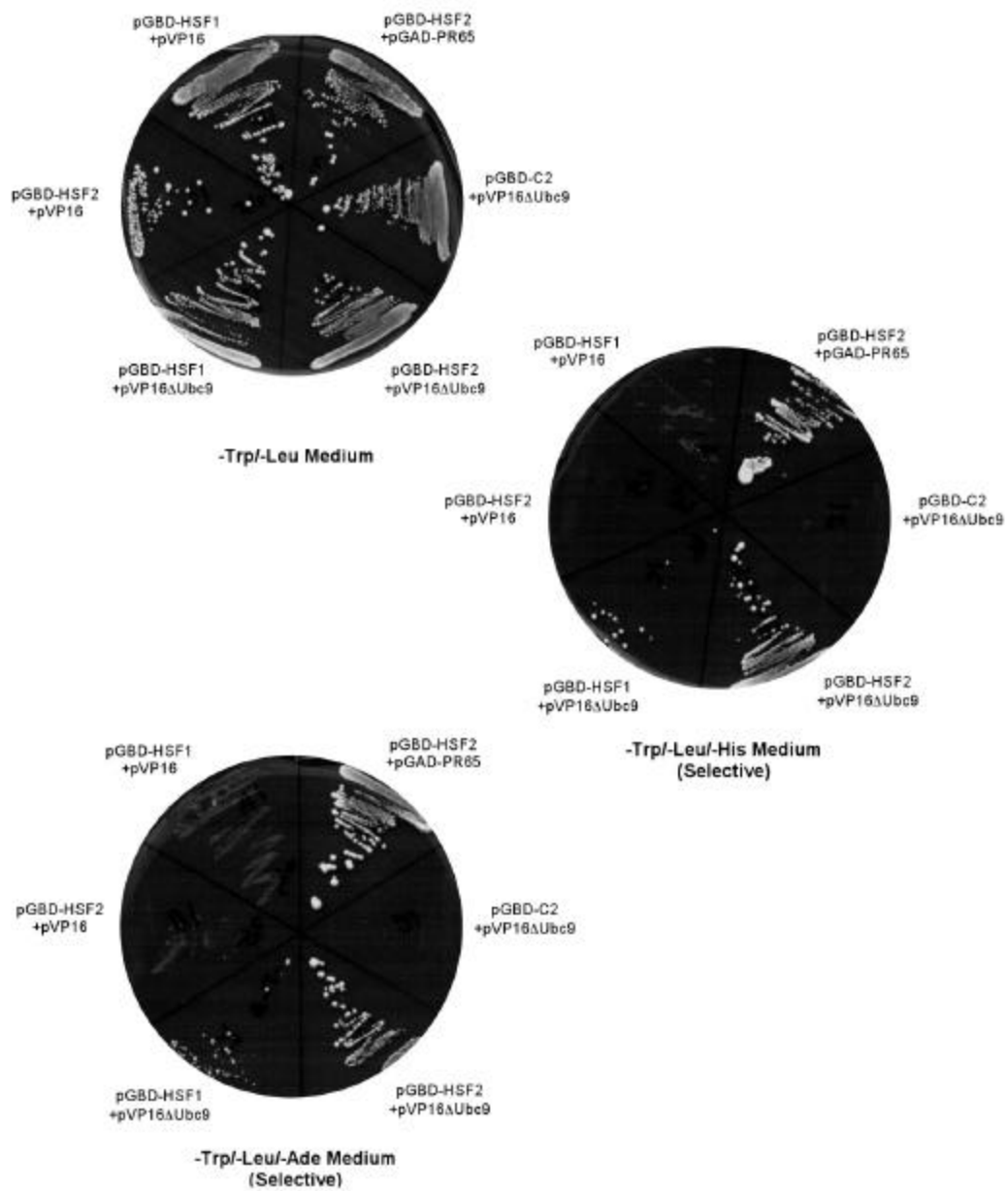
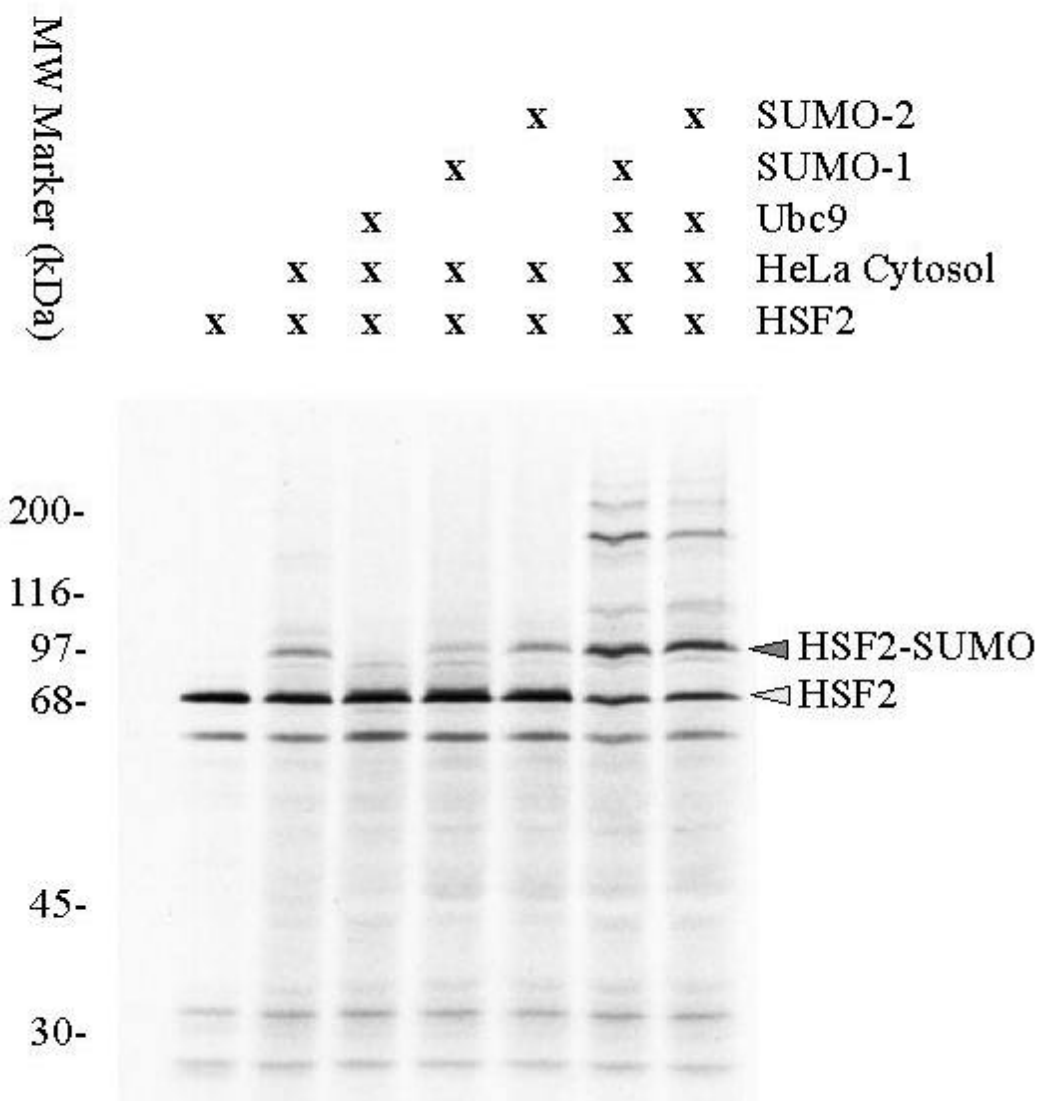

Figure 3.6: *In vitro* SUMO-1 modification analysis of HSF1.

In vitro translated HSF1 protein is used as substrate in an *in vitro* SUMO-1 modification reaction. Addition of HeLa cytosol results in the appearance of several higher molecular weight products. The addition of SUMO-1 or Ubc9 or both does not affect the abundance or migration of these products, indicating that HSF1 is not a substrate for SUMO-1 modification *in vitro*. The higher molecular weight HSF1 products are likely the hyperphosphorylated states often observed with HSF1. By comparison HSF2 is a substrate for SUMO-1 modification. *In vitro* SUMO-1 modification assay performed by Dr. Michael J. Matunis.

Figure 3.6: *In vitro* SUMO-1 modification analysis of HSF1.

In vitro SUMO-1 modification assay of
in vitro transcribed and translated HSF1 cDNA (C12b)

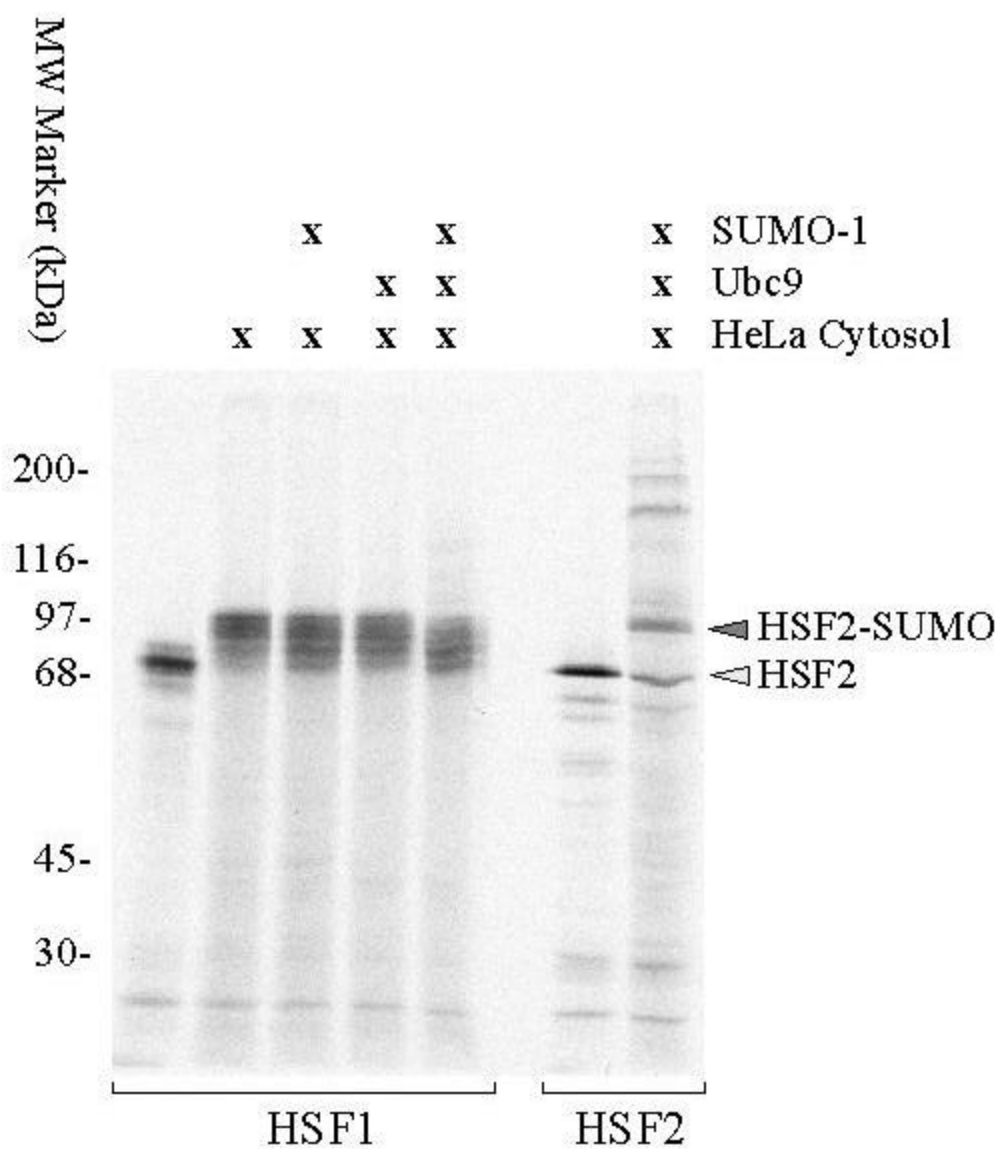

Figure 3.7: Colocalization of GFP-HSF2 and SUMO-1.

Transiently transfected HeLa cells expressing GFP-HSF2 were stained with an antibody against SUMO-1 and DAPI for nuclear staining. Shown are the GFP-HSF2 (green), SUMO-1 (red), and DAPI (blue) staining from three representative fields of cells. GFP-HSF2 and SUMO-1 colocalize (GFP-HSF2 + SUMO-1) in discrete domains (seen as yellow dots) with the nucleus (GFP-HSF2 + DAPI).

Figure 3.7: Colocalization of GSP-HSF2 and SUMO-1.

Figure 3.8: Unique localization of GFP-HSF2.

Transiently transfected HeLa cells expressing GFP, GFP-HSF1, or GFP-HSF2 were visualized by fluorescent microscopy. Two fields of cells are shown for each. GFP is expressed throughout the cytosol and nucleus. GFP-HSF1 expression is almost entirely confined to the nucleus. GFP-HSF2 is expressed predominantly in the cytosol with very little nuclear staining except for cells with nuclear domain staining.

Figure 3.8: Unique localization of GFP-HSF2.

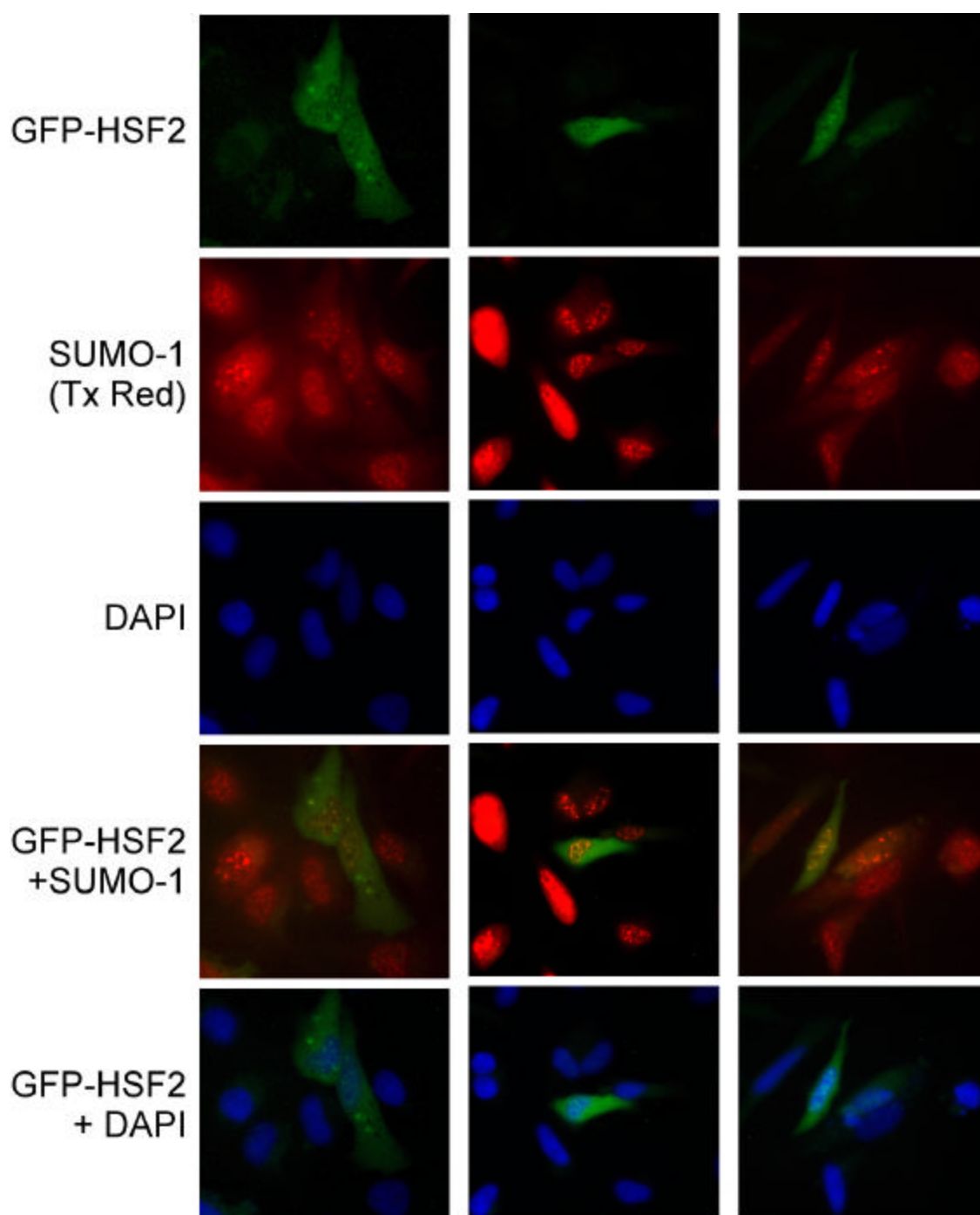
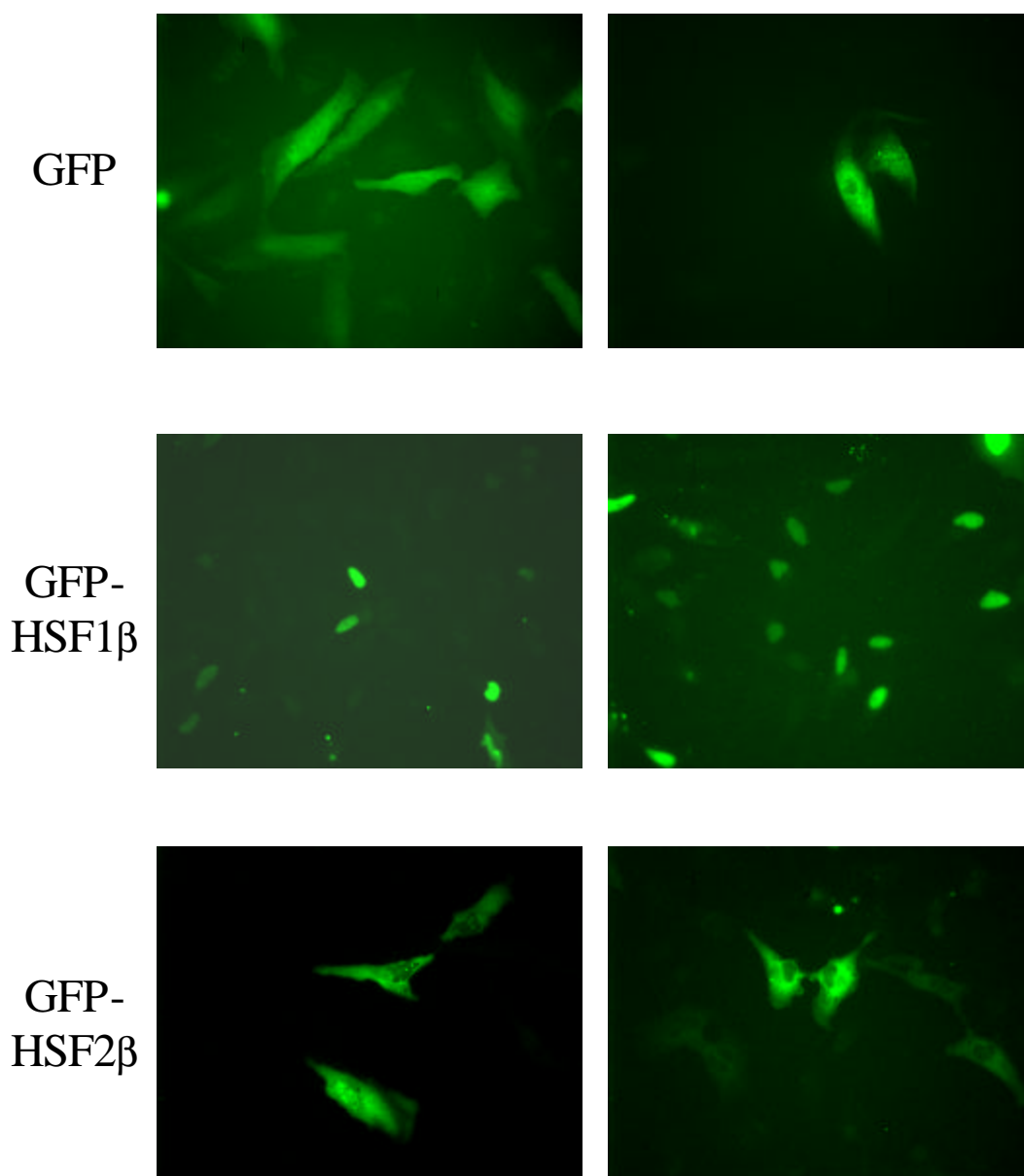
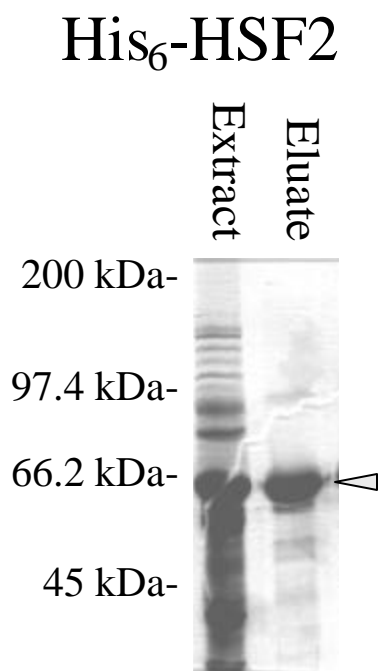

Figure 3.9: Purification of recombinant HSF2 and SUMO-1.

Cleared bacterial lysates (Extract) from bacteria expressing either His₆HSF2 or GST-SUMO-1 and purified eluate from the Ni/NTA agarose or glutathione agarose resins respectively (Eluate) were analyzed by SDS-PAGE and visualized by Coomassie staining.

Figure 3.9: Purification of recombinant HSF2 and SUMO-1.

GST-SUMO-1

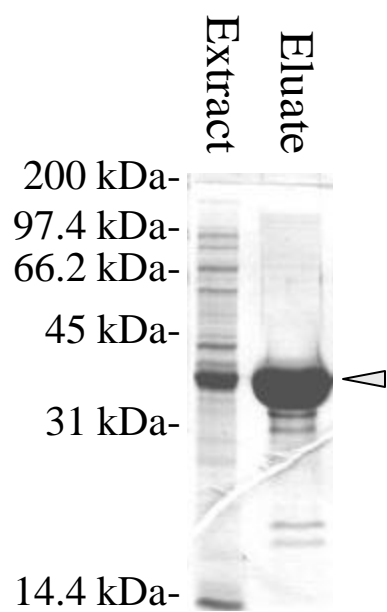

Figure 3.10: Preadsorbed control for SUMO-1 Immunofluorescent Staining.

HeLa cells transiently expressing GFP-HSF2 were stained with an antibody to SUMO-1 or an antibody to SUMO-1 that had been preadsorbed to 250 μ g of purified GST-SUMO-

1. Preadsorbing the SUMO-1 antibody with GST-SUMO-1 completely abolishes SUMO-1 nuclear domain staining.

Figure 3.10: Preadsorbed control for SUMO-1 Immunofluorescent Staining.

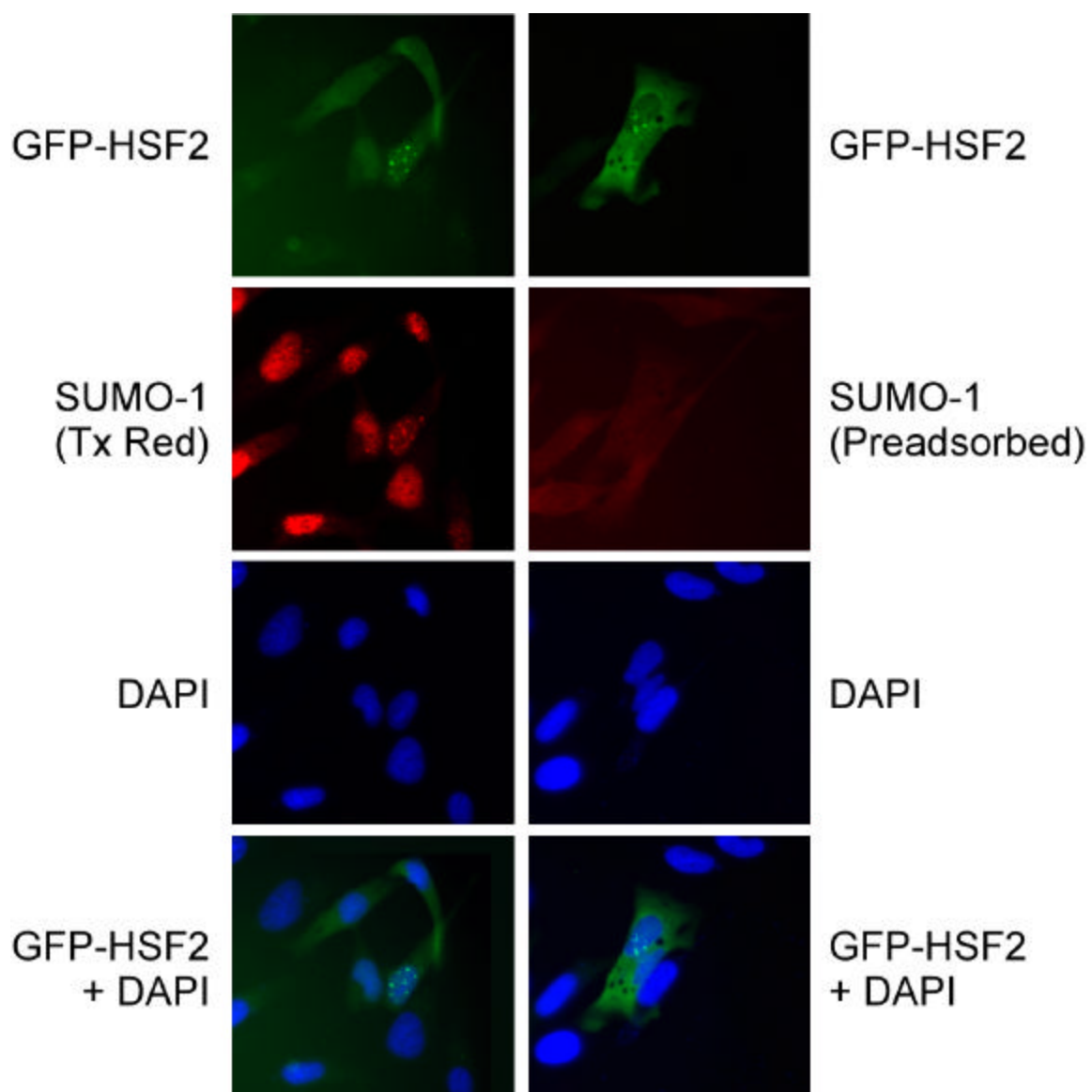

Figure 3.11: Consensus SUMO-1 modification site analysis of HSF2.

The mouse HSF2- α protein sequences was analyzed for the consensus SUMO-1 modification site sequence (isoleucine, leucine, or valine followed by lysine, any amino acid and finally a glutamate or aspartate residue). The analysis was performed using the PATTERNMATCH algorithm from Biology Workbench 3.2. HSF2 contains three consensus modification sites (indicated with bolded/underlined text) at lys82, lys139 and lys151. The 18 amino acids of the HSF2- α specific exon (amino acids 391-409) are italicized.

Figure 3.11: Consensus SUMO-1 modification site analysis of HSF2.

PATTERNMATCH analysis of mHSF2 α with [IVL]K. [ED]

MKQSSNVPAF LSKLWTLVEE THTNEFITWS QNGQSFLVLD EQRFAKEILP
 KYFKHNNMAS FVRQLNMYGF RKVVHIESGI IKQERDGPVE FQHPYFKQGQ
 DDLENIKRK VSSSKPEENK IRQEDLTKII SSAQKVIKQ ETIESRLSEL
KSENESLWKE VSELRAKHAQ QQQVIRKIVQ FIVTLVQNNQ LVSLKRRRPL
 LLNTNGAPKK NLYQHIVKEP TDNHHHKVPH SRTEGLKSRE RISDDIIIYD
 VTDDNVDEEN IPVIPETNED VVVDSSNQYP DIVIVEDDNE DEYAPVIQSG
 EQSEPAEPL RVGSAGSSSP LMSSAVQLNG SSSLTSEDPV TMMDSILNDN
 INLLGKVVELL DYLDSDICSL EDFQAMLSGR QFSIDPDLV DLFTSSVQMN
PTDNINNTKS ENKGLEATKS SVVQHVSEEG RKSKSKPKDQ LIQYTAFPLL
 AFLDGNSASA IEQGSTTASS EVVPSVDKPI EVDELLEDSSL DPEPTQSKLV
 RLEPLTEAEA SEATLFYLCE LAPAPLDSM PLLDS

Figure 3.12: *In vitro* modification analysis of HSF2 mutants.

In vitro translated pcDNA-HSF2 β -MH₆ (WT) and the SUMO-1 consensus site mutants K82R, K139R, and K151R were used as substrates in *in vitro* SUMO-1 modification reactions. The K82R mutation abolishes the majority of the SUMO-1 modification on HSF2. *In vitro* SUMO-1 modification assay performed by Dr. Michael J. Matunis.

Figure 3.12: *In vitro* modification analysis of HSF2 mutants.

In vitro SUMO-1 modification of
in vitro translated pcDNA-HSF2 β MH₆
(and mutants)

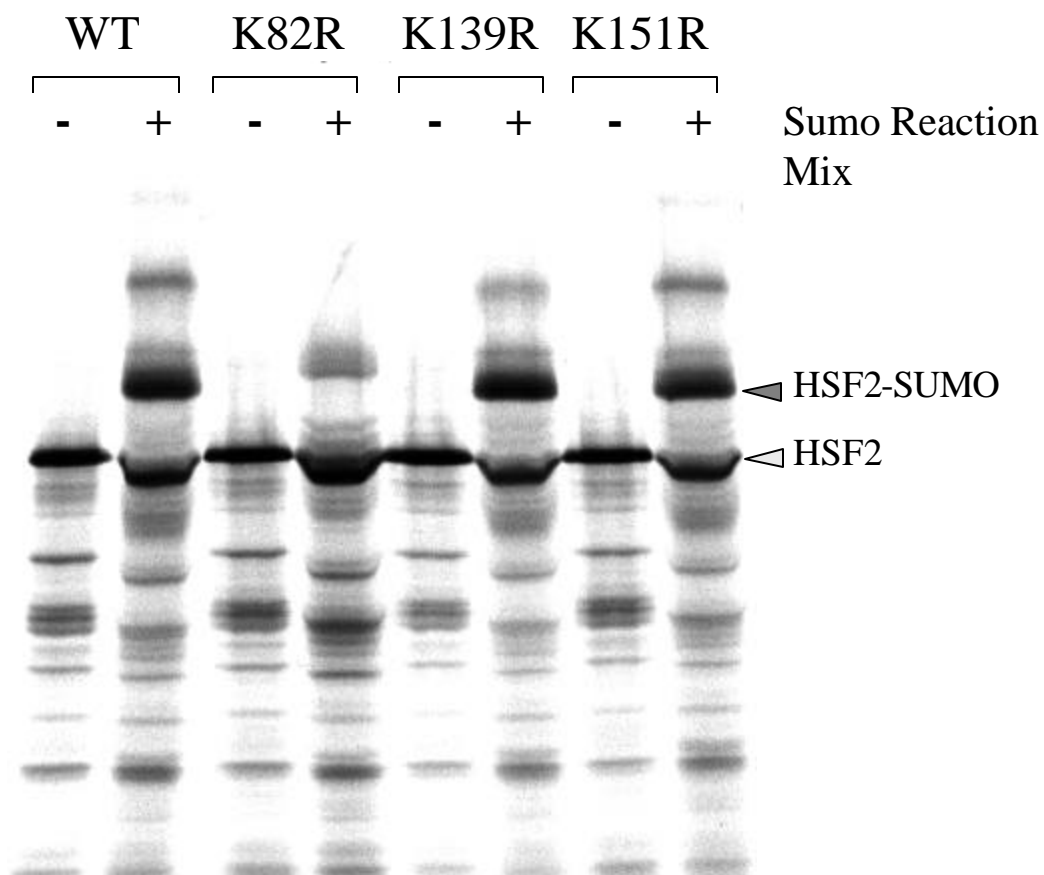

DISCUSSION

In this work we have demonstrated that *in vitro* translated HSF2, but not HSF1 is a substrate for SUMO-1 and SUMO-2 modification *in vitro*. Consistent with this, we have demonstrated that HSF2 can interact with a portion of Ubc9, the SUMO-1 conjugating enzyme, in a two-hybrid assay. We have also shown that GFP-HSF2 colocalizes with SUMO-1 in discrete nuclear domain structures in 7% of GFP-HSF2 expressing HeLa cells. Finally, we have shown that lysine 82 is the primary site of SUMO-1 modification *in vitro*.

These data suggest that the role of SUMO-1 modification of HSF2 is to target HSF2 to discrete nuclear domain structures. HSF2 nuclear dots have been observed previously (Sarge et al., 1993). These data provide a likely explanation for this observation. Examination of the localization of the GFP-HSF2(K82R) mutant should demonstrate whether this is the case. SUMO-1 modification causes several other proteins to become localized into nuclear domains. PML and Sp100 both localize to the same nuclear domain, ND10, while HIPK2 appears to form a second class of SUMO-1 containing nuclear domains (Duprez et al., 1999; Kim et al., 1999; Muller et al., 1998; Sternsdorf et al., 1999). Determining whether HSF2 colocalizes to one of these two nuclear domains or a novel nuclear domain will be important for determining the function of HSF2/SUMO-1 modification.

Interestingly, HSF2 is able to interact with a portion of HSF2 that contains over 75% of the full length Ubc9 protein, but cannot interact with full-length Ubc9 in the yeast two-hybrid assay. This observation could be an artifact due to the nature of both constructs. The partial Ubc9 construct is fused to the VP16 activation domain while full-

length Ubc9 construct is fused to the Gal4 activation domain. If, however, it is not an artifact, this would suggest that there are domains at either the very amino-terminus or the very carboxy-terminus of Ubc9 that regulate its interaction with HSF2. Further characterization of the domains in HSF2 and Ubc9 required for interaction may lead to insights into how SUMO-1 modification of HSF2 is regulated.

Interestingly, *in vivo* very little of the total HSF2 is SUMO-1 modified, but *in vitro* a large portion of HSF2 can be modified by SUMO-1. This would suggest that either a positive regulation event, such as phosphorylation of HSF2, occurs inappropriately in the *in vitro* modification assay, or a negative regulator of SUMO-1 modification of HSF2 is not present in the *in vitro* assay system. Negative regulators could include some modification of HSF2 itself or perhaps some protein that interacts with HSF2 to prevent SUMO-1 modification.

Understanding the events that regulate SUMO-1 modification will likely provide insights into the function of SUMO-1 modified HSF2 and ultimately into the general functions of both SUMO-1 and HSF2.

Chapter 4

Discussion and Future Directions

The results in this work present two novel ways in which the activity of HSFs are regulated. Both HSF1 and HSF2 undergo alternative splicing which gives rise to two protein isoforms for each. These alternative splicing events are regulated in a tissue dependent manner. In addition HSF2 alternative splicing within the testis is regulated in a germ cell type and developmental manner. HSF2, and not HSF1, is modified by the conjugation of the SUMO-1 protein to lysine 82 in approximately 7% of HeLa cells transiently expressing GFP-HSF2. The regulatory mechanism for SUMO-1 modification is not understood, though it appears as a consequence of SUMO-1 modification HSF2 becomes localized to nuclear domain structures.

The overall question that arises from these results is what are the functions of these modifications. What is the functional difference between HSF1- α and HSF1- β ? What is the functional difference between HSF2- α and HSF2- β ? What is the function of HSF2 localization to nuclear domains? What is the function of HSF2 in the cell? These are all important questions that will undoubtedly require a great deal of further research to understand. A few experiments to begin addressing these questions readily come to mind, however.

THE FUNCTIONAL DIFFERENCE BETWEEN HSF1-a AND HSF1-b.

Recently, we have obtained a full-length mouse HSF1- α expression plasmid. This construct could be used to determine if there are differences in the ability of HSF1- α and HSF1- β to activate gene transcription similar to those observed from HSF2. Also the

creation of an antibody specific to HSF1- α would make it possible to test if different stress conditions resulted in differential activation of HSF1- α versus HSF1- β . This would address the hypothesis that the isoforms function either to modulate the activation temperature or to broaden the temperature range over which the stress response can be activated.

THE POSSIBILITY OF STRESS INDUCED SUMO MODIFICATION OF HSF1.

The data from this work would suggest that HSF1 is not a substrate for SUMO-1 modification. Recent data however indicate that HSF1 forms nuclear granules upon activation by stress such as heat shock or cadmium treatment (Cotto et al., 1997). In addition, overall SUMO-2/3 conjugation is induced upon exposure of cells to stress such as those that cause HSF1 to become activate and to form nuclear granules (Saitoh and Hinchey, 2000). Taken together, these data suggest that HSF1 might be a substrate for SUMO modification under stress conditions. HSF1 that is *in vitro* translated does not bind to DNA suggesting that it is not in the active state, and therefore would not likely be a substrate for SUMO modification *in vitro* unless it was first activated by heat shock or some other stressful treatment. Further data indicates that HSF1 activated by treatment with 20 mM salycilate does not form nuclear granules even though it has been activated and can bind to DNA (Cotto et al., 1997). Previous work has shown that salycilate treatment does not induce the phosphorylation changes seen in HSF1 activated by other stresses (Cotto et al., 1996; Jurivich et al., 1995; Jurivich et al., 1992). This would suggest that a change in phosphorylation might be the regulatory event that is required for SUMO-1 or -2/3 modification of HSF1.

THE ROLE OF HSF2-a AND HSF2-b IN SPERMATOGENESIS.

Recent conflicting data may require us to reexamine our thinking about the role of HSF2 and the HSF2 isoforms in spermatogenesis. A recent paper indicates that HSF2 is not activated during spermatogenesis in rats, as it is for mice (Alastalo et al., 1998). Also, the data indicates that expression of hsp70 does not correlate with HSF2 expression during spermatogenesis (Alastalo et al., 1998). At least preliminarily HSF2 does not appear to be functioning to regulate the expression of hsps during spermatogenesis. Interestingly, this same work showed that HSF2 is localized to intracellular bridges in germ cells from zygotene spermatocytes through mature spermatozoa (Alastalo et al., 1998). The function of this HSF2 is not known. Initially we proposed that the increase in HSF2- α expression was to increase the amount of hsps and other HSF2 regulated proteins expressed during spermatogenesis. More research will be needed to understand the function of HSF2 and the HSF2 isoforms in the testis.

OTHER FUNCTIONS OF HSF2

Other than in testis, HSF2 is not found in the DNA binding form in any other tissue in adult mammals even though HSF2 is found in every tissue. This begs the question of what is function of HSF2. Recent data from our lab demonstrated that HSF2 interacts stably with PR65, a regulatory subunit of protein phosphatase 2A (PP2A) (Hong and Sarge, 1999). Interestingly HSF2 interacts with PR65 in the absence of the phosphatase catalytic subunit. The function of this interaction is not clear. Preliminary

efforts to determine if HSF2 functions to regulate PP2A activity by sequestering PR65 were inconclusive (Hong and Sarge, 1999). In preliminary experiments, however, PR65 colocalizes with GFP-HSF2 in nuclear domain structures, suggesting that PR65 can interact with SUMO-1 modified HSF2 (Y. Hong, data not shown). PR65 can, and clearly does, interact with unmodified HSF2 as well. Perhaps the function of the HSF2/SUMO-1 modification is to recruit PR65 to nuclear domains, though the functional consequence of this happening is not known.

THE REGULATION OF THE SUMO-1 MODIFICATION OF HSF2.

It is clear that to understand the function of SUMO-1 modification of HSF2 we must first understand its regulation. There are two regulatory events that need to be addressed. First is the issue of only certain cells containing SUMO-1 modified HSF2 in GFP-HSF2 transfection assays, and the second is the issue of only some of the HSF2 in a cell being SUMO-1 modified. Perhaps SUMO-1 modification of HSF2 is cell cycle regulated. The most direct way of examining this would be using immunofluorescence microscopy to visualize the HSF2 domain structures. Cell cycle regulation could be tested using synchronized cells harvested at different time points during the cell cycle or by using cell cycle sorted cells deposited onto slides. These experiments would require an antibody against HSF2 that lacked nonspecific background staining.

Also, understanding the events within the cell that regulate SUMO-1 modification of HSF2 will be critical to our overall understanding of SUMO-1 modification of HSF2. It is likely that some modification of HSF2 could be the regulatory event required for SUMO-1 modification of HSF2. Therefore, a basic understanding of how HSF2 is

modified is critical. Previous data indicates that HSF2 may be modified by the covalent attachment of O-linked N-acetylglucosamine to serine and threonine residues (data not shown). This modification is reciprocal with serine/threonine phosphorylation in certain cases (Hart, 1997; Jackson and Tjian, 1988; Kelly et al., 1993; Reason et al., 1992). Other modifications to examine might include methylation, acetylation, or even ubiquitination.

THE 26S PROTEOSOME AND SUMO MODIFICATION OF HSF2.

Recent studies indicate that HSF2 can be activated in cells treated with the drugs MG132 or lactacystin, which function to inhibit 26S proteasome function, or in ts85 cells which have a temperature sensitive mutation in the ubiquitin conjugating enzyme (E1) gene (Mathew et al., 1998). HSF2 has relatively short half-life of 60-70 minutes. Treatment of cells with proteasome inhibitors causes an increase in the levels of HSF2 as well as activation of HSF2 DNA binding and transcriptional activities. This is in part due to increases in levels of HSF2 expression and in part due to decreased HSF2 degradation (Mathew et al., 1998). No evidence has been seen for HSF2 ubiquitination, but due to the instability of ubiquitinated proteins, it can be difficult to observe them. Interestingly, the drug MG132 which inhibits the proteasome activity and activates HSF2 also leads to increased conjugation of SUMO-2/3 (Saitoh and Hinchey, 2000). Our data indicates that HSF2 is also a substrate for SUMO-2 modification *in vitro*. Perhaps MG132 induces SUMO-2/3 modification of HSF2 that is consequently resistant to protein degradation. Protein stabilization by SUMO-1 modification has been observed for I κ B as well as

possibly for p53. This might suggest that SUMO has multiple functions with respect to HSF2.

Answers to the above questions can lead to greater understanding of the functions of HSF2 and SUMO-1 in the cell. They can also lead to broader questions concerning the function of sub-domains and how the organization of nuclear activities leads to the appropriate gene regulation and protein expression in cell specific and developmental manners.

Appendix

APPENDIX A: LIST OF ABBREVIATIONS

HSF, heat shock factor

HSE, heat shock element

hsp, heat shock protein,

PML, promyelocytic leukemia protein

SUMO-1, small **u**biquitin-like **m**odifier-**1**

PCR, polymerase chain reaction

RT-PCR, reverse transcriptase couple PCR

DAPI, 4',6-diamidino-2-phenylindole

PBS, phosphate buffered saline

BSA, bovine serum albumin

FBS, fetal bovine serum

SDS-PAGE, sodium dodecylsulfate polyacrylamide gel electrophoresis

MeOH, methanol

RanGAP1, Ran GTPase activating protein-1

kb, kilobase

nt, nucleotide

kDa, kilodalton

References

- Alastalo, T.P., M. Lonnstrom, S. Leppa, K. Kaarniranta, M. Peltto-Huikko, L. Sistonen, and M. Parvinen. 1998. Stage-specific expression and cellular localization of the heat shock factor 2 isoforms in the rat seminiferous epithelium. *Exp Cell Res.* 240:16-27.
- Alberts, B., D. Bray, J. Lewis, M. Raff, K. Roberts, and J.D. Watson. 1989. *Molecular Biology of the Cell.* Garland Publishing, New York, NY.
- Amin, J., J. Ananthan, and R. Voellmy. 1988. Key features of heat shock regulatory elements. *Mol Cell Biol.* 8:3761-9.
- Amin, J., M. Fernandez, J. Ananthan, J.T. Lis, and R. Voellmy. 1994. Cooperative binding of heat shock transcription factor to the Hsp70 promoter in vivo and in vitro. *J Biol Chem.* 269:4804-11.
- Atchison, M.L. 1988. Enhancers: mechanisms of action and cell specificity. *Annu Rev Cell Biol.* 4:127-53.
- Baler, R., G. Dahl, and R. Voellmy. 1993. Activation of human heat shock genes is accompanied by oligomerization, modification, and rapid translocation of heat shock transcription factor HSF1. *Mol Cell Biol.* 13:2486-96.
- Bartel, P.L., C.-T. Chien, R. Sternglanz, and S. Fields. 1993. Using the Two Hybrid System to Detect Protein-Protein Interactions. *In Cellular Interactions in Development: A Practical Approach.* Vol. xviii. D.A. Hartley, editor. Oxford University Press, Oxford, England. 153-179.
- Bartel, P.L., and S. Fields. 1995. Analyzing protein-protein interactions using two-hybrid system. *Methods Enzymol.* 254:241-63.
- Bayer, P., A. Arndt, S. Metzger, R. Mahajan, F. Melchior, R. Jaenicke, and J. Becker. 1998. Structure determination of the small ubiquitin-related modifier SUMO-1. *J Mol Biol.* 280:275-86.
- Becker, J., and E.A. Craig. 1994. Heat-shock proteins as molecular chaperones. *Eur J Biochem.* 219:11-23.
- Bhattacharyya, T., A.N. Karnezis, S.P. Murphy, T. Hoang, B.C. Freeman, B. Phillips, and R.I. Morimoto. 1995. Cloning and subcellular localization of human mitochondrial hsp70. *J Biol Chem.* 270:1705-10.
- Brown, D.D. 1984. The role of stable complexes that repress and activate eucaryotic genes. *Cell.* 37:359-65.

- Brown, I.R. 1995. The stress response. *Neuropathol Appl Neurobiol.* 21:473-5.
- Burley, S.K., and R.G. Roeder. 1996. Biochemistry and structural biology of transcription factor IID (TFIID). *Annu Rev Biochem.* 65:769-99.
- Cech, T.R. 1986. The generality of self-splicing RNA: relationship to nuclear mRNA splicing. *Cell.* 44:207-10.
- Chambon, P. 1975. Eukaryotic nuclear RNA polymerases. *Annu Rev Biochem.* 44:613-38.
- Chambon, P. 1981. Split genes. *Sci Am.* 244:60-71.
- Chen, L. 1999. Combinatorial gene regulation by eukaryotic transcription factors. *Curr Opin Struct Biol.* 9:48-55.
- Chien, C.T., P.L. Bartel, R. Sternglanz, and S. Fields. 1991. The two-hybrid system: a method to identify and clone genes for proteins that interact with a protein of interest. *Proc Natl Acad Sci U S A.* 88:9578-82.
- Chu, B., F. Soncin, B.D. Price, M.A. Stevenson, and S.K. Calderwood. 1996. Sequential phosphorylation by mitogen-activated protein kinase and glycogen synthase kinase 3 represses transcriptional activation by heat shock factor-1. *J Biol Chem.* 271:30847-57.
- Clermont, U., and C. Huckins. 1961. Microscopic analysis of the sex cords and seminiferous tubules in growing and adult male albino rats. *Am J Anat.* 108:79-97.
- Clermont, Y. 1958. Contractile structures in the limiting membrane of the seminiferous tubules of the rat. *Expt Cell Res.* 15:438-440.
- Clos, J., J.T. Westwood, P.B. Becker, S. Wilson, K. Lambert, and C. Wu. 1990. Molecular cloning and expression of a hexameric *Drosophila* heat shock factor subject to negative regulation. *Cell.* 63:1085-97.
- Clos, J., S. Rabindran, J. Wisniewski, and C. Wu. 1993. Induction temperature of human heat shock factor is reprogrammed in a *Drosophila* cell environment. *Nature.* 364:252-5.
- Cotto, J., S. Fox, and R. Morimoto. 1997. HSF1 granules: a novel stress-induced nuclear compartment of human cells. *J Cell Sci.* 110:2925-34.
- Cotto, J.J., M. Kline, and R.I. Morimoto. 1996. Activation of heat shock factor 1 DNA binding precedes stress-induced serine phosphorylation. Evidence for a multistep pathway of regulation. *J Biol Chem.* 271:3355-8.
- Craig, E.A. 1993. Chaperones: helpers along the pathways to protein folding. *Science.* 260:1902-3.

- Craig, E.A., B.D. Gambill, and R.J. Nelson. 1993. Heat shock proteins: molecular chaperones of protein biogenesis. *Microbiol Rev.* 57:402-14.
- Craig, E.A., J.S. Weissman, and A.L. Horwich. 1994. Heat shock proteins and molecular chaperones: mediators of protein conformation and turnover in the cell. *Cell.* 78:365-72.
- Crick, F. 1979. Split genes and RNA splicing. *Science.* 204:264-71.
- Cullen, K.E., and K.D. Sarge. 1997. Characterization of hypothermia-induced cellular stress response in mouse tissues. *J Biol Chem.* 272:1742-6.
- de Wet, J.R., K.V. Wood, M. DeLuca, D.R. Helinski, and S. Subramani. 1987. Firefly luciferase gene: structure and expression in mammalian cells. *Mol Cell Biol.* 7:725-37.
- Delmas, V., F. van der Hoorn, B. Mellstrom, B. Jegou, and P. Sassone-Corsi. 1993. Induction of CREM activator proteins in spermatids: down-stream targets and implications for haploid germ cell differentiation. *Mol Endocrinol.* 7:1502-14.
- Desterro, J.M., M.S. Rodriguez, and R.T. Hay. 1998. SUMO-1 modification of IkappaBalpha inhibits NF-kappaB activation. *Mol Cell.* 2:233-9.
- Desterro, J.M., M.S. Rodriguez, G.D. Kemp, and R.T. Hay. 1999. Identification of the enzyme required for activation of the small ubiquitin-like protein SUMO-1. *J Biol Chem.* 274:10618-24.
- Desterro, J.M., J. Thomson, and R.T. Hay. 1997. Ubch9 conjugates SUMO but not ubiquitin. *FEBS Lett.* 417:297-300.
- Dreyfuss, G., M.S. Swanson, and S. Pinol-Roma. 1988. Heterogeneous nuclear ribonucleoprotein particles and the pathway of mRNA formation. *Trends Biochem Sci.* 13:86-91.
- Duprez, E., A.J. Saurin, J.M. Desterro, V. Lallemand-Breitenbach, K. Howe, M.N. Boddy, E. Solomon, H. de The, R.T. Hay, and P.S. Freemont. 1999. SUMO-1 modification of the acute promyelocytic leukaemia protein PML: implications for nuclear localisation. *J Cell Sci.* 112:381-93.
- Dym, M., and Y. Clermont. 1970. Role of spermatogonia in the repair of the seminiferous epithelium following x-irradiation of the rat testis. *Am J Anat.* 128:265-82.
- Dym, M., and D.W. Fawcett. 1970. The blood-testis barrier in the rat and the physiological compartmentation of the seminiferous epithelium. *Biol Reprod.* 3:308-26.
- Edmonds, M. 1987. Branched RNA. *Bioessays.* 6:212-6.
- Emerson, B.M., J.M. Nickol, P.D. Jackson, and G. Felsenfeld. 1987. Analysis of the tissue-specific enhancer at the 3' end of the chicken adult beta-globin gene. *Proc Natl Acad Sci U S A.* 84:4786-90.

- Espeseth, A.S., S.P. Murphy, and E. Linney. 1989. Retinoic acid receptor expression vector inhibits differentiation of F9 embryonal carcinoma cells. *Genes Dev.* 3:1647-56.
- Evans, R.M. 1988. The steroid and thyroid hormone receptor superfamily. *Science.* 240:889-95.
- Evans, T., M. Reitman, and G. Felsenfeld. 1988. An erythrocyte-specific DNA-binding factor recognizes a regulatory sequence common to all chicken globin genes. *Proc Natl Acad Sci U S A.* 85:5976-80.
- Everett, R.D., W.C. Earnshaw, A.F. Pluta, T. Sternsdorf, A.M. Ainsztein, M. Carmena, S. Ruchaud, W. Hsu, and A. Orr. 1999a. A dynamic connection between centromeres and ND10 proteins. *J Cell Sci.* 112:3443-3454.
- Everett, R.D., P. Lomonte, T. Sternsdorf, R. van Driel, and A. Orr. 1999b. Cell cycle regulation of PML modification and ND10 composition. *J Cell Sci.* 112:4581-4588.
- Farkas, T., Y.A. Kutsikova, and V. Zimarino. 1998. Intramolecular repression of mouse heat shock factor 1. *Mol Cell Biol.* 18:906-18.
- Fields, S., and O. Song. 1989. A novel genetic system to detect protein-protein interactions. *Nature.* 340:245-6.
- Fields, S., and R. Sternglanz. 1994. The two-hybrid system: an assay for protein-protein interactions. *Trends Genet.* 10:286-92.
- Foulkes, N.S., B. Mellstrom, E. Benusiglio, and P. Sassone-Corsi. 1992. Developmental switch of CREM function during spermatogenesis: from antagonist to activator. *Nature.* 355:80-4.
- Freeman, B.C., and R.I. Morimoto. 1996. The human cytosolic molecular chaperones hsp90, hsp70 (hsc70) and hdj-1 have distinct roles in recognition of a non-native protein and protein refolding. *Embo J.* 15:2969-79.
- Geiduschek, E.P., and G.P. Tocchini-Valentini. 1988. Transcription by RNA polymerase III. *Annu Rev Biochem.* 57:873-914.
- Giardina, C., and J.T. Lis. 1995. Sodium salicylate and yeast heat shock gene transcription. *J Biol Chem.* 270:10369-72.
- Gilbert, H.F. 1994. Protein chaperones and protein folding. *Curr Opin Biotechnol.* 5:534-9.
- Gong, L., S. Millas, G.G. Maul, and E.T. Yeh. 2000. Differential regulation of sentrinized proteins by a novel sentrin-specific protease. *J Biol Chem.* 275:3355-9.
- Gong, L., and E.T. Yeh. 1999. Identification of the activating and conjugating enzymes of the NEDD8 conjugation pathway. *J Biol Chem.* 274:12036-42.

Gostissa, M., A. Hengstermann, V. Fogal, P. Sandy, S.E. Schwarz, M. Scheffner, and G. Del Sal. 1999. Activation of p53 by conjugation to the ubiquitin-like protein SUMO-1. *Embo J.* 18:6462-6471.

Guthrie, C., and B. Patterson. 1988. Spliceosomal snRNAs. *Annu Rev Genet.* 22:387-419.

Hart, G.W. 1997. Dynamic O-GlcNAcylation of Nuclear and Cytoskeletal Proteins. *Ann Rev Biochem*:In Press.

Hendrick, J.P., and F.U. Hartl. 1993. Molecular chaperone functions of heat-shock proteins. *Annu Rev Biochem.* 62:349-84.

Hendrick, J.P., and F.U. Hartl. 1995. The role of molecular chaperones in protein folding. *Faseb J.* 9:1559-69.

Hershko, A., and A. Ciechanover. 1998. The ubiquitin system. *Annu Rev Biochem.* 67:425-79.

Hochstrasser, M. 1996. Ubiquitin-dependent protein degradation. *Annu Rev Genet.* 30:405-39.

Hodges, M., C. Tissot, and P.S. Freemont. 1998. Protein regulation: tag wrestling with relatives of ubiquitin. *Curr Biol.* 8:R749-52.

Hoj, A., and B.K. Jakobsen. 1994. A short element required for turning off heat shock transcription factor: evidence that phosphorylation enhances deactivation. *Embo J.* 13:2617-24.

Hong, Y., and K.D. Sarge. 1999. Regulation of protein phosphatase 2A activity by heat shock transcription factor 2. *J Biol Chem.* 274:12967-70.

Huckins, C. 1971. The spermatogonial stem cell population in adult rats. II. A radioautographic analysis of their cell cycle properties. *Cell Tissue Kinet.* 4:313-34.

Huckins, C. 1978a. The morphology and kinetics of spermatogonial degeneration in normal adult rats: an analysis using a simplified classification of the germinal epithelium. *Anat Rec.* 190:905-26.

Huckins, C. 1978b. Spermatogonial intercellular bridges in whole-mounted seminiferous tubules from normal and irradiated rodent testes. *Am J Anat.* 153:97-121.

Huckins, C., and E.F. Oakberg. 1978. Morphological and quantitative analysis of spermatogonia in mouse testes using whole mounted seminiferous tubules. II. The irradiated testes. *Anat Rec.* 192:529-42.

Ishov, A.M., A.G. Sotnikov, D. Negorev, O.V. Vladimirova, N. Neff, T. Kamitani, E.T. Yeh, J.F. Strauss, 3rd, and G.G. Maul. 1999. PML is critical for ND10 formation and

- recruits the PML-interacting protein daxx to this nuclear structure when modified by SUMO-1. *J Cell Biol.* 147:221-34.
- Jackson, S.P., and R. Tjian. 1988. O-glycosylation of eukaryotic transcription factors: implications for mechanisms of transcriptional regulation. *Cell.* 55:125-33.
- Jaffray, E., K.M. Wood, and R.T. Hay. 1995. Domain organization of I kappa B alpha and sites of interaction with NF-kappa B p65. *Mol Cell Biol.* 15:2166-72.
- James, P., J. Halladay, and E.A. Craig. 1996. Genomic Libraries and a Host Strain Designed for Highly Efficient Two-Hybrid Selection in Yeast. *Genomics.* 144:1425-36.
- Johnson, E.S., and G. Blobel. 1999. Cell cycle-regulated attachment of the ubiquitin-related protein SUMO to the yeast septins. *J Cell Biol.* 147:981-94.
- Jones, N.C., P.W. Rigby, and E.B. Ziff. 1988. Trans-acting protein factors and the regulation of eukaryotic transcription: lessons from studies on DNA tumor viruses. *Genes Dev.* 2:267-81.
- Jurivich, D.A., C. Pachetti, L. Qiu, and J.F. Welk. 1995. Salicylate triggers heat shock factor differently than heat. *J Biol Chem.* 270:24489-95.
- Jurivich, D.A., L. Sistonen, R.A. Kroes, and R.I. Morimoto. 1992. Effect of sodium salicylate on the human heat shock response. *Science.* 255:1243-5.
- Kamitani, T., K. Kito, H.P. Nguyen, T. Fukuda-Kamitani, and E.T. Yeh. 1998a. Characterization of a second member of the sentrin family of ubiquitin-like proteins. *J Biol Chem.* 273:11349-53.
- Kamitani, T., K. Kito, H.P. Nguyen, H. Wada, T. Fukuda-Kamitani, and E.T. Yeh. 1998b. Identification of three major sentrinization sites in PML. *J Biol Chem.* 273:26675-82.
- Kamitani, T., H.P. Nguyen, K. Kito, T. Fukuda-Kamitani, and E.T. Yeh. 1998c. Covalent modification of PML by the sentrin family of ubiquitin-like proteins. *J Biol Chem.* 273:3117-20.
- Kelly, W.G., M.E. Dahmus, and G.W. Hart. 1993. RNA polymerase II is a glycoprotein. Modification of the COOH-terminal domain by O-GlcNAc. *J Biol Chem.* 268:10416-24.
- Kim, J., A. Nueda, Y.H. Meng, W.S. Dynan, and N.F. Mivechi. 1997. Analysis of the phosphorylation of human heat shock transcription factor-1 by MAP kinase family members. *J Cell Biochem.* 67:43-54.
- Kim, Y.H., C.Y. Choi, and Y. Kim. 1999. Covalent modification of the homeodomain-interacting protein kinase 2 (HIPK2) by the ubiquitin-like protein SUMO-1. *Proc Natl Acad Sci U S A.* 96:12350-12355.

- Kline, M.P., and R.I. Morimoto. 1997. Repression of the heat shock factor 1 transcriptional activation domain is modulated by constitutive phosphorylation. *Mol Cell Biol.* 17:2107-15.
- Knauf, U., E.M. Newton, J. Kyriakis, and R.E. Kingston. 1996. Repression of human heat shock factor 1 activity at control temperature by phosphorylation. *Genes Dev.* 10:2782-93.
- Kozak, M. 1987. At least six nucleotides preceding the AUG initiator codon enhance translation in mammalian cells. *J Mol Biol.* 196:947-50.
- Kretz-Remy, C., and R.M. Tanguay. 1999. SUMO/sentrin: protein modifiers regulating important cellular functions. *Biochem Cell Biol.* 77:299-309.
- Krishan, A. 1987. Effect of drug efflux blockers on vital staining of cellular DNA with Hoechst 33342. *Cytometry.* 8:642-5.
- Kroll, M., M. Conconi, M.J. Desterro, A. Marin, D. Thomas, B. Friguet, R.T. Hay, J.L. Virelizier, F. Arenzana-Seisdedos, and M.S. Rodriguez. 1997. The carboxy-terminus of I kappaB alpha determines susceptibility to degradation by the catalytic core of the proteasome. *Oncogene.* 15:1841-50.
- Laemmli, U.K. 1970. Cleavage of structural proteins during the assembly of the head of bacteriophage T4. *Nature.* 227:680-5.
- Leblond, C.P., and Y. Clermont. 1952. Definition of the stages of the cycle of the seminiferous epithelium in the rat. *Ann N Y Acad Sci.* 55:548-573.
- Lee, G.W., F. Melchior, M.J. Matunis, R. Mahajan, Q. Tian, and P. Anderson. 1998. Modification of Ran GTPase-activating protein by the small ubiquitin-related modifier SUMO-1 requires Ubc9, an E2-type ubiquitin-conjugating enzyme homologue. *J Biol Chem.* 273:6503-7.
- Li, S.J., and M. Hochstrasser. 1999. A new protease required for cell-cycle progression in yeast. *Nature.* 398:246-51.
- Liu, Q., C. Jin, X. Liao, Z. Shen, D.J. Chen, and Y. Chen. 1999. The binding interface between an E2 (UBC9) and a ubiquitin homologue (UBL1). *J Biol Chem.* 274:16979-87.
- Mahajan, R., C. Delphin, T. Guan, L. Gerace, and F. Melchior. 1997. A small ubiquitin-related polypeptide involved in targeting RanGAP1 to nuclear pore complex protein RanBP2. *Cell.* 88:97-107.
- Mahajan, R., L. Gerace, and F. Melchior. 1998. Molecular characterization of the SUMO-1 modification of RanGAP1 and its role in nuclear envelope association. *J Cell Biol.* 140:259-70.

- Maniatis, T., S. Goodbourn, and J.A. Fischer. 1987. Regulation of inducible and tissue-specific gene expression. *Science*. 236:1237-45.
- Maniatis, T., and R. Reed. 1987. The role of small nuclear ribonucleoprotein particles in pre-mRNA splicing. *Nature*. 325:673-8.
- Mathew, A., S.K. Mathur, and R.I. Morimoto. 1998. Heat shock response and protein degradation: regulation of HSF2 by the ubiquitin-proteasome pathway. *Mol Cell Biol*. 18:5091-8.
- Matunis, M.J., E. Coutavas, and G. Blobel. 1996. A novel ubiquitin-like modification modulates the partitioning of the Ran-GTPase-activating protein RanGAP1 between the cytosol and the nuclear pore complex. *J Cell Biol*. 135:1457-70.
- Matunis, M.J., J. Wu, and G. Blobel. 1998. SUMO-1 modification and its role in targeting the Ran GTPase-activating protein, RanGAP1, to the nuclear pore complex. *J Cell Biol*. 140:499-509.
- McKnight, S.L., and R. Kingsbury. 1982. Transcriptional control signals of a eukaryotic protein-coding gene. *Science*. 217:316-24.
- Mendelsohn, A.R., and R. Brent. 1994. Applications of interaction traps/two-hybrid systems to biotechnology research. *Curr Opin Biotechnol*. 5:482-6.
- Mezger, V., M. Rallu, R.I. Morimoto, M. Morange, and J.P. Renard. 1994. Heat shock factor 2-like activity in mouse blastocysts. *Dev Biol*. 166:819-22.
- Mivechi, N.F., and A.J. Giaccia. 1995. Mitogen-activated protein kinase acts as a negative regulator of the heat shock response in NIH3T3 cells. *Cancer Res*. 55:5512-9.
- Monesi, V. 1965. Synthetic activities during spermatogenesis in the mouse. RNA and protein. *Expt. Cell Res*. 39:197-224.
- Morano, K.A., and D.J. Thiele. 1999. Heat shock factor function and regulation in response to cellular stress, growth, and differentiation signals. *Gene Expr*. 7:271-82.
- Morimoto, R.I. 1998. Regulation of the heat shock transcriptional response: cross talk between a family of heat shock factors, molecular chaperones, and negative regulators. *Genes Dev*. 12:3788-96.
- Morimoto, R.I., P.E. Kroeger, and J.J. Cotto. 1996. The transcriptional regulation of heat shock genes: a plethora of heat shock factors and regulatory conditions. *Exs*. 77:139-63.
- Morimoto, R.I., K.D. Sarge, and K. Abravaya. 1992. Transcriptional regulation of heat shock genes. A paradigm for inducible genomic responses. *J Biol Chem*. 267:21987-90.
- Moses, M.J. 1969. Structure and function of the synaptonemal complex. *Genetics*. 61:Suppl:41-51.

- Mosser, D.D., N.G. Theodorakis, and R.I. Morimoto. 1988. Coordinate changes in heat shock element-binding activity and HSP70 gene transcription rates in human cells. *Mol Cell Biol.* 8:4736-44.
- Muller, S., M.J. Matunis, and A. Dejean. 1998. Conjugation with the ubiquitin-related modifier SUMO-1 regulates the partitioning of PML within the nucleus. *Embo J.* 17:61-70.
- Murphy, S.P., J.J. Gorzowski, K.D. Sarge, and B. Phillips. 1994. Characterization of constitutive HSF2 DNA-binding activity in mouse embryonal carcinoma cells. *Mol Cell Biol.* 14:5309-17.
- Nakai, A., Y. Kawazoe, M. Tanabe, K. Nagata, and R.I. Morimoto. 1995. The DNA-binding properties of two heat shock factors, HSF1 and HSF3, are induced in the avian erythroblast cell line HD6. *Mol Cell Biol.* 15:5268-78.
- Nakai, A., M. Tanabe, Y. Kawazoe, J. Inazawa, R.I. Morimoto, and K. Nagata. 1997. HSF4, a new member of the human heat shock factor family which lacks properties of a transcriptional activator. *Mol Cell Biol.* 17:469-81.
- Nomiyama, H., C. Fromental, J.H. Xiao, and P. Chambon. 1987. Cell-specific activity of the constituent elements of the simian virus 40 enhancer. *Proc Natl Acad Sci U S A.* 84:7881-5.
- Oakberg, E.F. 1956. A description of spermiogenesis in the mouse and its use in analysis of the cycle of seminiferous epithelium and germ cell renewal. *Am J Anat.* 99:391-413.
- Ogbourne, S., and T.M. Antalis. 1998. Transcriptional control and the role of silencers in transcriptional regulation in eukaryotes. *Biochem J.* 331:1-14.
- Okuma, T., R. Honda, G. Ichikawa, N. Tsumagari, and H. Yasuda. 1999. In vitro SUMO-1 modification requires two enzymatic steps, E1 and E2. *Biochem Biophys Res Commun.* 254:693-8.
- Orphanides, G., T. Lagrange, and D. Reinberg. 1996. The general transcription factors of RNA polymerase II. *Genes Dev.* 10:2657-83.
- Osheim, Y.N., O.L. Miller, Jr., and A.L. Beyer. 1985. RNP particles at splice junction sequences on Drosophila chorion transcripts. *Cell.* 43:143-51.
- Padgett, R.A., P.J. Grabowski, M.M. Konarska, S. Seiler, and P.A. Sharp. 1986. Splicing of messenger RNA precursors. *Annu Rev Biochem.* 55:1119-50.
- Perisic, O., H. Xiao, and J.T. Lis. 1989. Stable binding of Drosophila heat shock factor to head-to-head and tail-to-tail repeats of a conserved 5 bp recognition unit. *Cell.* 59:797-806.
- Perry, R.P. 1981. RNA processing comes of age. *J Cell Biol.* 91:28s-38s.

- Pfanner, N., E.A. Craig, and M. Meijer. 1994. The protein import machinery of the mitochondrial inner membrane. *Trends Biochem Sci.* 19:368-72.
- Pirkkala, L., T.P. Alastalo, P. Nykanen, L. Seppa, and L. Sistonen. 1999. Differentiation lineage-specific expression of human heat shock transcription factor 2. *Faseb J.* 13:1089-98.
- Poukka, H., P. Aarnisalo, U. Karvonen, J.J. Palvimo, and O.A. Janne. 1999. Ubc9 interacts with the androgen receptor and activates receptor-dependent transcription. *J Biol Chem.* 274:19441-6.
- Rabindran, S.K., G. Giorgi, J. Clos, and C. Wu. 1991. Molecular cloning and expression of a human heat shock factor, HSF1. *Proc Natl Acad Sci U S A.* 88:6906-10.
- Rabindran, S.K., R.I. Haroun, J. Clos, J. Wisniewski, and C. Wu. 1993. Regulation of heat shock factor trimer formation: role of a conserved leucine zipper. *Science.* 259:230-4.
- Rao-Naik, C., W. delaCruz, J.M. Laplaza, S. Tan, J. Callis, and A.J. Fisher. 1998. The rub family of ubiquitin-like proteins. Crystal structure of Arabidopsis rub1 and expression of multiple rubs in Arabidopsis. *J Biol Chem.* 273:34976-82.
- Reason, A.J., H.R. Morris, M. Panico, R. Marais, R.H. Treisman, R.S. Haltiwanger, G.W. Hart, W.G. Kelly, and A. Dell. 1992. Localization of O-GlcNAc modification on the serum response transcription factor. *J Biol Chem.* 267:16911-21.
- Reed, R., and T. Maniatis. 1988. The role of the mammalian branchpoint sequence in pre-mRNA splicing. *Genes Dev.* 2:1268-76.
- Rio, D.C. 1992a. RNA binding proteins, splice site selection, and alternative pre-mRNA splicing. *Gene Expr.* 2:1-5.
- Rio, D.C. 1992b. RNA processing. *Curr Opin Cell Biol.* 4:444-52.
- Rodriguez, M.S., J.M. Desterro, S. Lain, C.A. Midgley, D.P. Lane, and R.T. Hay. 1999. SUMO-1 modification activates the transcriptional response of p53. *Embo J.* 18:6455-6461.
- Roeder, R.G. 1996. The role of general initiation factors in transcription by RNA polymerase II. *Trends Biochem Sci.* 21:327-35.
- Roosen-Runge, E.C. 1973. Germinal-cell loss in normal metazoan spermatogenesis. *J Reprod Fertil.* 35:339-48.
- Russell, L. 1977. Movement of spermatocytes from the basal to the adluminal compartment of the rat testis. *Am J Anat.* 148:313-28.

- Russell, L., and B. Frank. 1978. Characterization of rat spermatocytes after plastic embedding. *Arch Androl.* 1:5-18.
- Russell, L.D. 1978. The blood-testis barrier and its formation relative to spermatocyte maturation in the adult rat: a lanthanum tracer study. *Anat Rec.* 190:99-111.
- Russell, L.D., R.A. Ettl, A.P. Sinha-Hikim, and E.D. Clegg. 1990. Histological and Histopathological Evaluation of the Testis. Cache River Press, Clearwater, FL.
- Saitoh, H., and J. Hinchey. 2000. Functional Heterogeneity of Small Ubiquitin-related Protein Modifiers SUMO-1 versus SUMO-2/3. *J Biol Chem.* 275:6252-6258.
- Saitoh, H., R.T. Pu, and M. Dasso. 1997. SUMO-1: wrestling with a new ubiquitin-related modifier. *Trends Biochem Sci.* 22:374-6.
- Samarina, O.P., A.A. Krichevskaya, and G.P. Georgiev. 1966. Nuclear ribonucleoprotein particles containing messenger ribonucleic acid. *Nature.* 210:1319-22.
- Sarge, K.D., S.P. Murphy, and R.I. Morimoto. 1993. Activation of heat shock gene transcription by heat shock factor 1 involves oligomerization, acquisition of DNA-binding activity, and nuclear localization and can occur in the absence of stress [published errata appear in *Mol Cell Biol* 1993 May;13(5):3122-3 and 1993 Jun;13(6):3838-9]. *Mol Cell Biol.* 13:1392-407.
- Sarge, K.D. 1995. Male germ cell-specific alteration in temperature set point of the cellular stress response. *J Biol Chem.* 270:18745-8.
- Sarge, K.D., A.E. Bray, and M.L. Goodson. 1995. Altered stress response in testis [letter]. *Nature.* 374.
- Sarge, K.D., S.O. Park, J.D. Kirby, K.E. Mayo, and R.I. Morimoto. 1994. Expression of heat shock factor 2 in mouse testis: potential role as a regulator of heat-shock protein gene expression during spermatogenesis. *Biol Reprod.* 50:1334-43.
- Sarge, K.D., V. Zimarino, K. Holm, C. Wu, and R.I. Morimoto. 1991. Cloning and characterization of two mouse heat shock factors with distinct inducible and constitutive DNA-binding ability. *Genes Dev.* 5:1902-11.
- Schiller, P., J. Amin, J. Ananthan, M.E. Brown, W.A. Scott, and R. Voellmy. 1988. Cis-acting elements involved in the regulated expression of a human HSP70 gene. *J Mol Biol.* 203:97-105.
- Schuetz, T.J., G.J. Gallo, L. Sheldon, P. Tempst, and R.E. Kingston. 1991. Isolation of a cDNA for HSF2: evidence for two heat shock factor genes in humans. *Proc Natl Acad Sci U S A.* 88:6911-5.
- Schulman, I.G., D. Chakravarti, H. Juguilon, A. Romo, and R.M. Evans. 1995. Interactions between the retinoid X receptor and a conserved region of the TATA-binding

protein mediate hormone-dependent transactivation. *Proc Natl Acad Sci U S A*. 92:8288-92.

Sentenac, A. 1985. Eukaryotic RNA polymerases. *CRC Crit Rev Biochem*. 18:31-90.

Shatkin, A.J. 1987. mRNA caps--old and newer hats. *Bioessays*. 7:275-7.

Shi, Y., P.E. Kroeger, and R.I. Morimoto. 1995. The carboxyl-terminal transactivation domain of heat shock factor 1 is negatively regulated and stress responsive. *Mol Cell Biol*. 15:4309-18.

Sisodia, S.S., B. Sollner-Webb, and D.W. Cleveland. 1987. Specificity of RNA maturation pathways: RNAs transcribed by RNA polymerase III are not substrates for splicing or polyadenylation. *Mol Cell Biol*. 7:3602-12.

Sistonen, L., K.D. Sarge, B. Phillips, K. Abravaya, and R.I. Morimoto. 1992. Activation of heat shock factor 2 during hemin-induced differentiation of human erythroleukemia cells. *Mol Cell Biol*. 12:4104-11.

Smale, S.T., and R. Tjian. 1985. Transcription of herpes simplex virus tk sequences under the control of wild-type and mutant human RNA polymerase I promoters. *Mol Cell Biol*. 5:352-62.

Sollner-Webb, B., and J. Tower. 1986. Transcription of cloned eukaryotic ribosomal RNA genes. *Annu Rev Biochem*. 55:801-30.

Steitz, J.A. 1988. "Snurps". *Sci Am*. 258:56-60, 63.

Sternsdorf, T., K. Jensen, B. Reich, and H. Will. 1999. The nuclear dot protein sp100, characterization of domains necessary for dimerization, subcellular localization, and modification by small ubiquitin-like modifiers. *J Biol Chem*. 274:12555-66.

Stuart, R.A., D.M. Cyr, E.A. Craig, and W. Neupert. 1994. Mitochondrial molecular chaperones: their role in protein translocation. *Trends Biochem Sci*. 19:87-92.

Suzuki, T., A. Ichiyama, H. Saitoh, T. Kawakami, M. Omata, C.H. Chung, M. Kimura, N. Shimbara, and K. Tanaka. 1999. A new 30-kDa ubiquitin-related SUMO-1 hydrolase from bovine brain. *J Biol Chem*. 274:31131-4.

Tanaka, K., J. Nishide, K. Okazaki, H. Kato, O. Niwa, T. Nakagawa, H. Matsuda, M. Kawamukai, and Y. Murakami. 1999. Characterization of a Fission Yeast SUMO-1 Homologue, Pmt3p, Required for Multiple Nuclear Events, Including the Control of Telomere Length and Chromosome Segregation. *Mol Cell Biol*. 19:8660-8672.

Theodorakis, N.G., D.J. Zand, P.T. Kotzbauer, G.T. Williams, and R.I. Morimoto. 1989. Hemin-induced transcriptional activation of the HSP70 gene during erythroid maturation in K562 cells is due to a heat shock factor-mediated stress response. *Mol Cell Biol*. 9:3166-73.

- Umesono, K., and R.M. Evans. 1989. Determinants of target gene specificity for steroid/thyroid hormone receptors. *Cell*. 57:1139-46.
- Umesono, K., K.K. Murakami, C.C. Thompson, and R.M. Evans. 1991. Direct repeats as selective response elements for the thyroid hormone, retinoic acid, and vitamin D3 receptors. *Cell*. 65:1255-66.
- Varshavsky, A. 1997. The ubiquitin system. *Trends Biochem Sci*. 22:383-7.
- Verrijzer, C.P., and R. Tjian. 1996. TAFs mediate transcriptional activation and promoter selectivity [see comments]. *Trends Biochem Sci*. 21:338-42.
- Vierstra, R.D., and J. Callis. 1999. Polypeptide tags, ubiquitous modifiers for plant protein regulation. *Plant Mol Biol*. 41:435-42.
- Voellmy, R. 1996. Sensing stress and responding to stress. *Exs*. 77:121-37.
- Weber, J.E., and L.D. Russell. 1987. A study of intercellular bridges during spermatogenesis in the rat. *Am J Anat*. 180:1-24.
- Westwood, J.T., and C. Wu. 1993. Activation of Drosophila heat shock factor: conformational change associated with a monomer-to-trimer transition. *Mol Cell Biol*. 13:3481-6.
- Workman, J.L., and R.G. Roeder. 1987. Binding of transcription factor TFIID to the major late promoter during in vitro nucleosome assembly potentiates subsequent initiation by RNA polymerase II. *Cell*. 51:613-22.
- Xia, W., Y. Guo, N. Vilaboa, J. Zuo, and R. Voellmy. 1998. Transcriptional activation of heat shock factor HSF1 probed by phosphopeptide analysis of factor 32P-labeled in vivo. *J Biol Chem*. 273:8749-55.
- Xia, W., and R. Voellmy. 1997. Hyperphosphorylation of heat shock transcription factor 1 is correlated with transcriptional competence and slow dissociation of active factor trimers. *J Biol Chem*. 272:4094-102.
- Zuo, J., R. Baler, G. Dahl, and R. Voellmy. 1994. Activation of the DNA-binding ability of human heat shock transcription factor 1 may involve the transition from an intramolecular to an intermolecular triple-stranded coiled-coil structure. *Mol Cell Biol*. 14:7557-68.

Vitae

Michael L. Goodson
Birthplace: Alton, Illinois
May 27, 1969

EDUCATION

University of Illinois at Urbana-Champaign. B.S. in Biochemistry, May, 1993.

Senior Thesis: “The Purification of Recombinant *Bacillus subtilis* Aspartate Transcarbamylase from *Escherichia coli*”, under the direction of Dr. Robert L. Switzer.

PROFESSIONAL POSITIONS

Research Technician--**University of Kentucky--Department of Biochemistry**

Visiting Teaching Associate--**University of Illinois--Department of Biochemistry**

Co-operative Student--**Nalco Chemical Company**, Naperville, IL

PUBLICATIONS

DeBeer, M. C., DeBeer, F. C., Gerardot, C. J., Cecil, D. R., Webb, N. R., Goodson, M. L., and Kindy, M. S. (1996) Structure of the Mouse *Saa4* Gene and Its Link to the Serum Amyloid A Gene Family. *Genomics* 34, 138-142.

Goodson, M. L., Park-Sarge, O. K., and Sarge, K. D. (1995) Tissue Dependent Expression of Heat Shock Factor 2 Isoforms with Distinct Transcriptional Activities. *Mol. Cell. Biol.* 15, 5288-5293.

Goodson, M. L. and Sarge, K. D. (1995) Regulated Expression of Heat Shock Factor 1 Isoforms with Distinct Leucine Zipper Arrays via Tissue-Dependent Alternative Splicing. *Biochem. Biophys. Res. Comm.* 211, 943-949.

Sarge, K. D., A. E. Bray, and M. L. Goodson. (1995) Altered Stress Response in Testis. *Nature* 374, 126.

Goodson, M. L. and K. D. Sarge. (1995) Heat Inducible DNA Binding of Purified Heat Shock Transcription Factor 1 (HSF1). *J. Bio. Chem.* 270, 2447-2550.

POSTERS

Hong, Y., Goodson, M.L., and Sarge, K.D. (1999) Regulation of Protein Phosphatase 2A Activity by Interaction with Heat Shock Transcription Factor 2. American Society for Biochemistry and Molecular Biology 1999 Meeting. San Francisco, CA.

Oz, H.S., Goodson, M.L., Goodwin, J.C., Gharib, S., Sternberg, P.W., and Katz, W.S. (1999) *lin-18*, a gene necessary for vulval cell orientation, encodes a Ryk-like predicted transmembrane tyrosine kinase. The 12th International *C. elegans* Meeting. Madison, WI.

Goodson, M. L., Park-Sarge, O.-K., and Sarge, K. D. (1996) Regulation of Heat Shock Factor 2 Activity in the Testis. The Fifteenth Annual University of Kentucky Symposium in Reproductive Sciences. Lexington, KY.

Goodson, M. L., Gothard, L. Q., Cullen, K. E., and Sarge, K. D. (1996) Regulation of HSF1 and HSF2 Function in Mouse Cells. 1996 Meeting on Molecular Chaperones and the Heat Shock Response. Cold Spring Harbor, NY.

