



University of Kentucky  
UKnowledge

---

University of Kentucky Master's Theses

Graduate School

---

2010

## ANALYSIS AND OPTIMIZATION OF ELECTRICAL SYSTEMS IN A SOLAR CAR WITH APPLICATIONS TO GATO DEL SOL III-IV

Krishna Venkatesh Prayaga  
*University of Kentucky, kvpray2@uky.edu*

[Right click to open a feedback form in a new tab to let us know how this document benefits you.](#)

---

### Recommended Citation

Prayaga, Krishna Venkatesh, "ANALYSIS AND OPTIMIZATION OF ELECTRICAL SYSTEMS IN A SOLAR CAR WITH APPLICATIONS TO GATO DEL SOL III-IV" (2010). *University of Kentucky Master's Theses*. 29.  
[https://uknowledge.uky.edu/gradschool\\_theses/29](https://uknowledge.uky.edu/gradschool_theses/29)

This Thesis is brought to you for free and open access by the Graduate School at UKnowledge. It has been accepted for inclusion in University of Kentucky Master's Theses by an authorized administrator of UKnowledge. For more information, please contact [UKnowledge@lsv.uky.edu](mailto:UKnowledge@lsv.uky.edu).

## **ABSTRACT OF THESIS**

### **ANALYSIS AND OPTIMIZATION OF ELECTRICAL SYSTEMS IN A SOLAR CAR WITH APPLICATIONS TO GATO DEL SOL III-IV**

Gato del Sol III, was powered by a solar array of 480 Silicon mono-crystalline photovoltaic cells. Maximum Power Point trackers efficiently made use of these cells and tracked the optimal load. The cells were mounted on a fiber glass and foam core composite shell. The shell rides on a lightweight aluminum space frame chassis, which is powered by a 95% efficient brushless DC motor. Gato del Sol IV was the University of Kentucky Solar Car Team's (UKSCT) entry into the American Solar Car Challenge (ASC) 2010 event. The car makes use of 310 high density lithium-polymer batteries to account for a 5 kWh pack, enough to travel over 75 miles at 40 mph without power generated by the array. An in-house battery protection system and charge balancing system ensure safe and efficient use of the batteries. Various electrical sub-systems on the car communicate among each other via Controller Area Network (CAN). This real time data is then transmitted to an external computer via RF communication for data collection.

Keywords: Battery Management, Controller Area Network, Power Point Tracking, Brushless Motor, Energy Management

Krishna Venkatesh Prayaga

11/14/2010

ANALYSIS AND OPTIMIZATION OF ELECTRICAL SYSTEMS IN A SOLAR CAR  
WITH APPLICATIONS TO GATO DEL SOL III-IV

By

Krishna Venkatesh Prayaga

Dr Vijay P Singh

Director of Thesis

Dr Stephen Gedney

Director of Graduate Studies

11/14/2010



THESIS

Krishna Venkatesh Prayaga

The Graduate School  
University of Kentucky  
2010

ANALYSIS AND OPTIMIZATION OF ELECTRICAL SYSTEMS IN A SOLAR CAR  
WITH APPLICATIONS TO GATO DEL SOL III-IV

---

Thesis

---

A Thesis submitted in partial fulfillment of the requirements for the degree of Master of  
Science in Electrical Engineering in the College of Engineering at the University of  
Kentucky

By

Krishna Venkatesh Prayaga

Lexington, Kentucky

Director: Dr Vijay P Singh, Professor of Electrical Engineering

Lexington, Kentucky

2010

## Acknowledgments

At the outset I would like to thank my thesis advisor Dr Vijay Singh for mentoring and guiding me during this research. The knowledge and experience I gained while working with the team will be invaluable. I would like to thank Dr. Larry Holloway and Dr. Paul Dolloff for being a part of my graduate thesis committee and providing their views on my work.

I extend gratitude to Mr. Ralph G Anderson (Belcan), for supporting the solar car team, I thank Advanced Circuits for sponsoring our PCBs and I would like to thank the team's corporate sponsors for making this work possible.

I thank Tektronix and Mr. Nathan Weaver for donating an oscilloscope on such short notice, it contributed tremendously in decreasing the down-time.

I thank Raghu Mangu for helping me out when I first started working on this project. I also thank him for helping me populate the PCBs. I would like to thank Sam Nicaise, Raghu and Matt Deye for discussing my thoughts on the car which helped in forming clear ideas. I thank Dale Reid for helping me with his designs of the Battery Protection System and the CAN boards on Gato del sol III.

Thanks must go to the previous and present team members of the solar car team. I also thank all the team members for two fantastic races, the Formula Sun Grand Prix (FSGP) 2009 and the American Solar Car Challenge (ASC) 2010 event, and wish the team good luck.

I also would like to thank my family and friends for their incredible support.

## Contents

<b>Acknowledgments .....</b>	<b>iii</b>
<b>List of Tables .....</b>	<b>vii</b>
<b>Table of Figures.....</b>	<b>viii</b>
<b>Chapter 1 Introduction.....</b>	<b>1</b>
1.1 Overview	1
1.2 UK Solar Car Team-History	2
1.3 Thesis Outline	4
<b>Chapter 2 Communication Bus Standards.....</b>	<b>5</b>
2.1 Overview	5
2.2 Problem Statement	5
2.3 Background	5
2.4 Controller Area Network	6
2.4.1 Arbitration	7
2.5 Universal Serial Bus Standard	7
2.6 Inter-integrated circuit	8
2.7 Ethernet	9
2.8 Adopted Bus Protocol – Design Solution	9
2.8.1 Physical Implementation	10
2.8.2 Hardware Implementation	12
2.8.3 Software Implementation	13
2.9 Results	14
<b>Chapter 3 Batteries and Battery Systems.....</b>	<b>16</b>
3.1 Background	16



3.2	Batteries	17
3.2.1	Nickel Cadmium battery technology	18
3.2.2	Nickel Metal Hydride battery technology	18
3.2.3	Sealed Lead Acid battery technology	19
3.2.4	Rechargeable Alkaline battery technology	19
3.2.5	Lithium-Ion battery Technology	20
3.3	Battery Protection System	21
3.3.1	Definitions	21
3.3.2	Problem Statement	22
3.3.3	Battery-Pack Design	23
3.3.4	Design Solution	24
3.3.5	Battery Balancing Systems – Problem Statement	27
3.3.6	Estimation of State of Charge	30
3.3.7	Charging Algorithms	31
3.3.8	Balancing Circuits-A Review	32
3.3.9	Strategy– Battery Balancing design	36
3.4	Results	39
<b>Chapter 4 Photovoltaic Array and Power Point Tracking .....</b>		<b>42</b>
4.1	Definitions	42
4.2	Solar-Cell Array Design-Problem Statement	43
4.3	Power Point Tracker – Problem Statement	47
4.4	Working of an MPPT	48
4.4.1	Perturb and Observe	49
4.4.2	Constant Voltage and Current	49
4.4.3	Power Point Trackers – UK Solar car team	50
<b>Chapter 5 Drive Systems .....</b>		<b>52</b>
5.1	Overview	52
5.2	Background	52

5.3 Issues Resolved	54
<b>Chapter 6 Conclusion and Future Work .....</b>	<b>56</b>
6.1 Overview	56
6.2 Hardware	56
6.3 Software	58
6.4 Future Work	58
6.5 Energy Management	60
<b>Appendix.....</b>	<b>61</b>
Appendix-A	61
Appendix-B	62
<b>Bibliography .....</b>	<b>64</b>
<b>Vita .....</b>	<b>67</b>

## **List of Tables**

Table 1 History of Battery R&D.....	16
Table 2 Comparison Of Secondary Battery Characteristics .....	18
Table 3 Weight Limits-ASC 2010 .....	22
Table 4 Table Comparing Three Drive Systems .....	53

## Table of Figures

Figure 1	Can Bus Network - One.....	11
Figure 2	Can Bus Network - Two.....	11
Figure 3	Can Board (Gato Del Sol IV) .....	13
Figure 4	Charging Phase-Discharging Phase.....	17
Figure 5	BPS Schematic .....	24
Figure 6	BPS Boards (Gato Del Sol III And Gato Del Sol IV) .....	27
Figure 7	An Unbalanced Pack .....	29
Figure 8	Voltage Vs. SoC (Typical Li-Po Cell).....	31
Figure 9	Passive Balancing (17) .....	33
Figure 10	Flying Capacitor (17).....	34
Figure 11	Derivations Of The Flying Capacitor Model (17) .....	34
Figure 12	Switched Transformer (17).....	35
Figure 13	Energy Converting Designs.....	36
Figure 14	CBS Schematic .....	37
Figure 15	CBS.....	38
Figure 16	Active Charge Balancing System-Block Diagram .....	39
Figure 17	Gato Del Sol IV Top Shell .....	44
Figure 18	Gato Del Sol III Top Shell.....	45
Figure 19	A GaAs Solar Cell .....	45
Figure 20	MPPT Generic Block Diagram .....	48

## **Chapter 1 Introduction**

### **1.1 Overview**

Gato del sol III was University of Kentucky solar car team's (UKSCT) entry to the Formula Sun Grand Prix (FSGP) 2009 event, the race was organized on a motorsports ranch in Cresson, TX.

Gato del sol IV was UKSCT's entry into the ASC2010 event, the race started in Cresson, TX with scrutineering and qualifying held on the motor sports ranch and the open-road race starting in Tulsa, OK and terminating in Naperville, IL.

Scrutineering is a process in which the organizers, mostly engineers (Professional Engineers) working in related industries, check the design and construction of the car to ascertain that the vehicle meets all the regulations which include dimension specifications and driver safety. Scrutineering is divided into four segments,

#### **Battery and Battery Protection System:**

The race rules mandate that only certain types of secondary batteries must be used during the race. Depending on the battery chemistry, it is required that the battery pack should have a dedicated battery protection system (BPS), during this process the organizers also check and confirm that the battery pack has been fused appropriately.

#### **Electrical Scrutineering:**

Different from the battery and battery protection scrutineering, during this phase, the organizers among other tests check to confirm that the chassis is properly isolated from the high-voltage bus.

#### **Array Scrutineering:**

This segment involves evaluating the array to check that based on the type of solar cells, the array size is within the specified limits. For example, the maximum array area for Gallium Arsenide (GaAs) solar cells was 6.00 m<sup>2</sup> and for arrays based on Silicon cells, the maximum area allowed was 9.00 m<sup>2</sup>.

Scrutineering is followed by qualifying, during the ASC 2010, cars that cleared scrutineering were also required to prove that they could finish a certain number of laps over a three-day period, this confirmed that, the team and the car had the capability to finish at least a fixed distance each day which meant reduced race management issues for the organizers.

This culminated into the open road race, where the teams that cleared the qualifying would start based on the number of laps they finished during qualifying. The team with most laps during qualifying took the pole position and the rest of the teams followed behind.

These events are primarily organized for proof of concept and hence are categorized as endurance events (or borrowing a term from bike racing, *time trails*), therefore it is very important to make sure that the team's entry is reliable.

## **1.2 UK Solar Car Team-History**

Over 10 years of learning, engineering, and persistence has propelled the University of Kentucky Solar Car Team to the national stage. After securing second place at the 2009 FSGP and a ninth place finish in the 2010 ASC, the motivation has skyrocketed to build the country's fastest, safest, most efficient solar car. Though the team has come a long way, the legacy of the University of Kentucky Solar Car Team did not start with such grandeur.

In 1999, a handful of engineering students proposed the idea of the first solar-powered car in the state of Kentucky. With the support of UK's College of Engineering, the solar car club was started and a team of few engineers started working on building the first solar powered car, Gato Del Sol I (named after the 1982 Kentucky Derby winning horse).

Driving Gat del Sol I, the 4 wheeled, fiber glass mammoth, the team made it to their first race in 2003, the American Solar Challenge but could not qualify for the open-road race. The following year provided for an opportunity to design and race an improved car. In 2004, the team came back after securing a second place in the stock (i.e. silicon solar cell) class at the National level Formula Sun Grand Prix.

Gato del Sol I provided for a great start to the team, but a more competitive car was needed. 2004 marked the beginning of development on Gato del Sol II. A shift to a rigid fiberglass/polystyrene composite shell with a more aerodynamic foil significantly decreased the power consumption. A lighter chassis and shell contributed to a 50% reduction in weight. Substituting the nickel metal hydride battery pack in Gato del sol I for lead acid batteries, and mono-crystalline silicon cells for poly-crystalline silicon cells contributed for a huge boost in power.

The new and improved vehicle made its first presence at the 2005 North American Solar Challenge. Due to a few late additions, some electrical mishaps kept the car off the road race. Though the team was unsuccessful at getting a car in the race, it was the inspiration and vision stemming from this experience that cultivated the future success of the team.

Work and improvements to Gato del Sol II continued through the end of 2007 when a revision of the race rules was released for the 2008 North American Solar Challenge, these changes required a significant redesign of the car. A much stronger chassis, higher capacity lithium polymer batteries, reliable maximum power point trackers, and a partially re-modeled shell marked the renaming of the car from Gato del Sol II to Gato del Sol III. The diligence learned through this redesign and the past race experiences paid off when the team qualified for their first ever North American Solar Challenge in 2008. Gato del Sol III was 5<sup>th</sup> to pass the pre-race scrutineering, 4<sup>th</sup> through qualifying. After experiencing a few mechanical and electrical hurdles through the 2800 miles, the team finished 11<sup>th</sup> out of the 14 racing teams, and 24 original entrants.

Gato del Sol III was entered in the next year's competition, the *Formula Sun Grand Prix* (FSGP) at Cresson, Texas, the car demonstrated unparalleled reliability and finished second over 100 laps behind the first place finisher.

Buoyed by the success in the past two events, the team set about on an arduous task of constructing a new solar car, Gato del sol IV, primarily for the American Solar Car Challenge 2010, the car qualified for the race and finished the race in 9<sup>th</sup> position behind the 8<sup>th</sup> placed team by a margin of 57 seconds.

### **1.3 Thesis Outline**

The remainder of this document describes all the work completed, it describes the problems encountered and solutions developed, this document also summarizes how the solutions performed and if they failed the reason for failure and suggested amendments have been documented.

**Chapter 2, Communication Bus Standards**, presents an overview of communication bus standards, draws comparison between the mentioned protocols and then gives a description of the hardware, software and physical implementation of the adopted protocol in Gato del sol IV.

**Chapter 3, Battery and Battery Systems**, presents an overview of secondary battery chemistries, this chapter answers the question – Why the solar car team prefers the Lithium-Polymer battery chemistry, and also describes, in-detail, electronic systems developed to ensure safe operation of this battery chemistry. This chapter also presents the design process of the present battery pack and its performance is also documented. The hardware and software implementation of the battery systems is also documented in this chapter.

**Chapter 4, PV and PV Tracking Systems**, this chapter presents the PV array design process and also discusses briefly about maximum power point trackers (MPPTs) purchased from DriveTek AG.

**Chapter 5, Drive Systems**, this chapter presents the design process of the drive system of the car, the team during the writing of this thesis has purchased major components of the drive system.

**Chapter 6, Conclusions and Future Direction**, this chapter presents the author's conclusions of the entire project pertaining to the electrical systems and also suggests future course of action and the direction for software and hardware upgrades.



## **Chapter 2    Communication Bus Standards**

### **2.1    Overview**

A large number of communication protocols have been developed for inter processor communication. The protocols have been developed with a particular application or application area in mind, therefore usage of a protocol in an area or application for which it was not intended carries with it multiple trade-offs. This chapter will draw comparison between a few protocols the author is familiar with.

### **2.2    Problem Statement**

Gato del sol III had a CAN bus network that was inherently limited, an addition or removal of a node would cause the bus to fail; this led to many difficulties during race events due to the interdependence of the CAN bus network on the number of nodes on the CAN bus. CAN identifiers on Gato del sol III's network were assigned in a random manner- this sometimes caused important message frames to be dropped and less important messages to be transmitted.

The FSGP 2009 presented a related issue with the CAN bus network, sometimes while trying to start the car, assuming all the BPS boards cleared the tests (voltage and temperature self-check) – the Master BPS would not close the P-channel MOSFETs because its buffer would overflow with the CAN messages and it would miss BPS\_STAT\_OK messages from other BPS boards.

With Gato del sol IV, the decision to move to a system that was easily expandable and robust was made.

### **2.3    Background**

The solar car is an amalgamation of electrical sub-systems that are required to communicate with each other at all times, a constant mode of communication also leads to live telemetry which helps the strategy team in making certain decisions. The following requirements were stipulated based on the application (1) (solar car).

- High Speed interface: The bus should be capable of transmitting messages at a very high data rate.

- Expansion: Ease of adding nodes to the available system without changing much of the hardware or software.
- Moderately long bus: Nodes might have to transfer messages to nodes sitting about 10 meters away.
- Noise: Electromagnetic interference will be a cause of concern in the solar car environment.
- Power: The system should be able to operate on limited power
- Fast reaction times: The ability to transmit messages without having to wait for a request for data or without having to wait for an arbiter.
- Multi-master and peer-to-peer communication: The protocol must allow multi-master nodes and peer-to-peer communication.
- Error detection and error correction: Algorithms and mechanisms to detect errors and take corrective measures should be defined in the specification
- Ease of implementation
- Cost of system implementation

## **2.4 Controller Area Network**

Controller Area Network (CAN) (2) was created for inter processor communication without a host processor. The protocol was developed in the 1980's for use in the automotive industry. In this application, the protocol is used as a communication channel between components like the Engine Management System (ECU), the traction control system, the transmission control system and the climate control system.

CAN is a serial protocol broadcast based bus. The bus can have multiple masters, which means that any node can initiate a message transfer. CAN runs at relatively high data rates ranging from 125 kbps to 1 Mbps, it offers excellent EMI rejection and effective error detection algorithms. The protocol is designed for short bursts of messages ranging from 0 – 8 bytes, with either standard or extended identifier formats (11 bit or 29 bit). Arbitration is completely non-destructive, the node sending the higher priority message wins arbitration, the node that loses arbitration resends the message when is

detects that the bus is free. Although CAN was primarily developed for the automotive industry, its use has spread to industrial and avionics applications (31).

CAN2.0B specification forms the lowest levels of DeviceNet, CANOpen and CANKingdom, and other higher level protocols (HLPs).

The CAN specification defines the physical and data link layers (layers 1 and 2 in the OSI model). Each CAN frame typically consists of 7 fields, shown in the Table 2.

#### **2.4.1 Arbitration**

CAN employs carrier sense multiple access with collision detect (CSMA/CD) mechanism in order to arbitrate access of the bus. It uses a priority scheme to resolve collisions by bit banging the identifiers, therefore arbitration is completely non-destructive, the node that loses arbitration resends data once it senses (carrier sense) that the bus is free.

On the CAN bus, 'zero' is nominated as the dominant bit. Therefore, if one node is transmitting 'one' whilst another is transmitting 'zero' the bus is at logic 'zero' and because a transmitter is constantly sensing the carrier, if it detects that the level of the bus is different from the level it is transmitting, it is assumed that the node has lost transmission and will withdraw without transmitting another bit.

#### **2.5 Universal Serial Bus Standard**

Intel's universal serial bus standard (USB) (3) was designed as a multi-point replacement to the Recommended Standard 232 (RS232) standard, USB is a high-speed serial interface that can also provide power to the devices connected to it. A USB bus is limited in the number of nodes it can support due to the 7-bit address field out of which 0 cannot be used as it is reserved, the bus supports these nodes with a four-wire cable of up to 5 meters in length.

The development of the USB specification can be traced back to three generations. The USB 1.1 version itself supports two bit rates, called the low speed with a bit-rate of 1.5 mega-bit per second (Mbps), low speed makes the bus less susceptible to EMI, thus reducing cost of implementing the system, and a full speed version with a bit-

rate of 12 Mbps. The USB 2.0 version also called the *high-speed* version can support a maximum bit-rate of 480 Mbps, the USB 2.0 standard has been the mainstay of communication between a desktop PC and human interface devices (HID) for nearly half of this decade. The third generation, USB 3.0 or the *super-speed* version was released by the *USB Implementers Forum Inc.* in August 2008, and the products with this generation of the specification are arriving in the market, this generation supports data rates of up to 4800 Mbps.

The bus is strictly host-controlled, and the specification allows for the presence of only one host at any given time. The specification does not support a multi-master topology. The host is responsible for initiating all transfers and also for scheduling bandwidth. Data is sent by various transaction methods using a token-based protocol.

The USB 2.0 standard had included a host-negotiation protocol, so devices with host capability can take control of the bus based on the protocol. USB is a four-wire interface implemented using a four-core shielded cable. Two types of connectors are specified, Type A and Type B.

## **2.6 Inter-integrated circuit**

Inter-Integrated circuit (I<sup>2</sup>C) (4) bus standard was developed by Philips in the early 1980's. I<sup>2</sup>C is a low to medium speed serial bus, it provides good support for communication with various slow, on-board peripheral devices that are accessed intermittently, while requiring extremely low hardware resources (31).

It is a simple, low-bandwidth, short distance protocol. Most available devices operate at speeds of up to 400 kilo-bits per second (kbps), the protocol is easy to implement to link multiple devices together because it uses a built-in addressing scheme.

Philips originally developed the specification for communication between devices in a television set, but due to the simplicity of the protocol, it has been adopted in several embedded systems environments.

The two signal lines defined in the protocol are called, *Serial Data* or SDA and *Serial Clock* or SCL. Together, these signals make it possible to support serial

transmission of 8-bits of data, a 7-bit address and control bits over the two-wire bus. The device that initiates transfer on the bus is called the *Master*, typically the master controls the clock signal, and a device being addressed by the master is called a *slave*. Standard I<sup>2</sup>C devices operate at data rates of up to 100 Kbps, and fast-mode devices can operate at data rates of up to 400 kbps, the 2.0 version of the protocol has included a high-speed mode which can support data rates of up to 3.4 Mbps.

## **2.7 Ethernet**

Ethernet (7) was developed at the Xerox Palo Alto Research Center in the 1970's by Dr Robert M. Metcalfe. It uses carrier sense multiple access and collision detection scheme for its medium access control (MAC) mechanism (31).

The specification defines the data-link layer of the OSI model and is widely accepted and used for a variety of networking applications. Industrial higher level protocols (HLP) have been defined over Ethernet and TCP/IP, the specification provides for varied data transfer rates of up to 1000 Mbps. Traditionally, Ethernet is non-deterministic, which means that the specification will demonstrate variable packet latency under load. HLPs are required to implement network, transport and application layers of the OSI model. Data delivery is not guaranteed by the specification, therefore the HLPs must be capable of detecting and re-sending dropped frames. Unlike the previous protocols, this specification allows for a variable data field width, varying between 46 to 1500 bytes (31).

## **2.8 Adopted Bus Protocol-Design Solution**

While there are advantages to each one of the protocols mentioned above and many more protocols which have not been mentioned in this thesis, the choice was made to go with CAN.

I<sup>2</sup>C was eliminated because of the poor EMI rejection capabilities and the comparatively low bus length, Ethernet does not have the real-time or soft-real time capabilities of the other busses, USB does not provide for a multiple master bus.

CAN is in common use in industrial networks, the network is used in conditions very similar to that of a solar car. It was originally designed for use in automobile control

and data-transfer system. The power point trackers from DriveTek AG and the motor controller from Tritium Power Electronics Engineering, use CAN as built-in standard interface systems.

### **2.8.1 Physical Implementation**

The physical implementation of the bus in the solar car is based on a twisted pair of 22 AWG co-axial cables, the frequency of twisting is – one twist per inch of cable. The bus is based on differential signaling mechanism, which means that the logical level of the bus at any given time is the difference between the two signal lines (CANH and CANL). Twisting of a coaxial cable in a communication system using differential signaling exposes both the cables to the common mode noise source, thus inducing noise into both signal lines and therefore in-effect not affecting the logic-level of the differential signal.

Gato del sol III had one CAN bus network running all around the car, the bus had 10 nodes, four BPS boards, one current sensor board, four MPPTs and one telemetry node, the bus operated at a bit-rate of 125 kbps. Operating at lower speeds increases the systems capability to reject EMI and decreasing the bit rate decreases the slew rate and therefore decreases the possibility of the chip generating considerable EMI.

Gato del sol IV has two separate CAN bus networks, one bus has 18 nodes, four BPS boards, four CBS boards, eight MPPTs, one current sensor and one telemetry node, this bus operates at a bit-rate of 125 kbps. The second bus runs around the Motor controller, the driver's interface box and the telemetry node-2 which feeds data to the LCD screen via I<sup>2</sup>C, this bus operates at a data rate of 1 Mbps.

Two separate busses have been used for Gato del sol IV because, there is lot of information exchange between the driver's interface box and the Tritium Motor controller, if they were included on CAN bus 1, the CAN bus system would have been very inefficient .

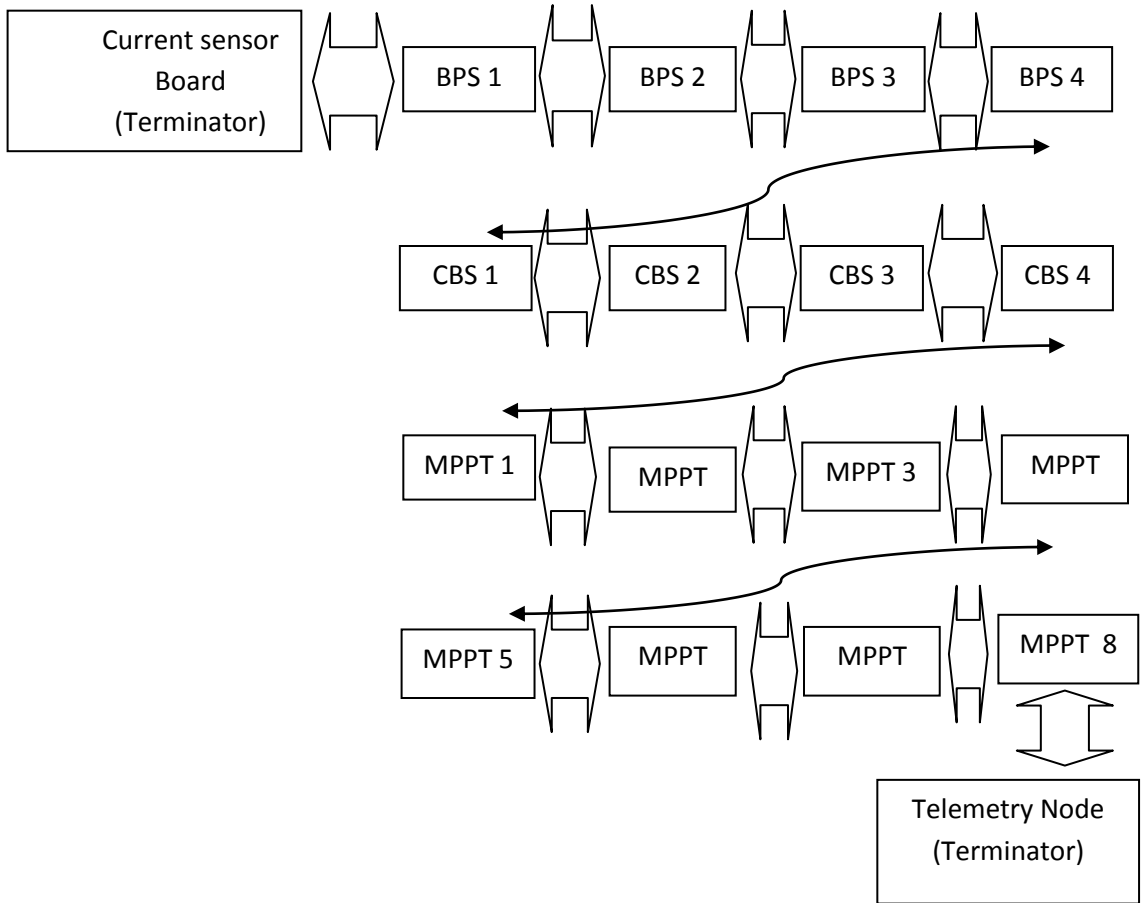

**Figure 1 CAN Bus Network - One**

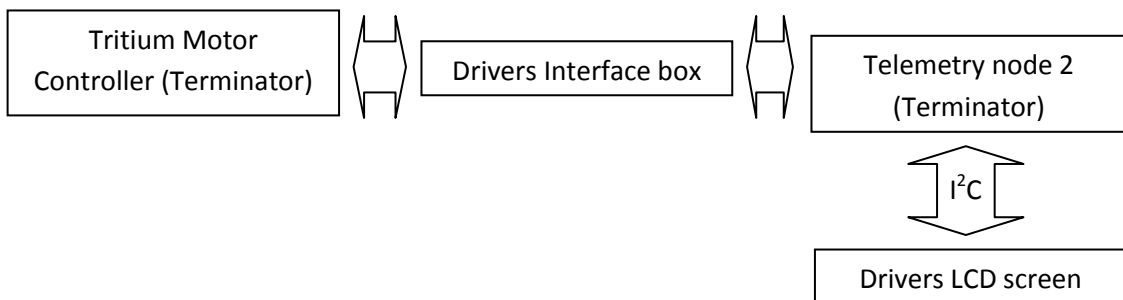

**Figure 2 CAN Bus Network - Two**

## 2.8.2 Hardware Implementation

All the boards (PCB's) on the car are capable of communicating via CAN. The boards can be divided into two types, one where the boards are assigned a specific task and in addition have the capability to interface with the outside world via CAN, boards falling under this category are the BPS, the CBS, the MPPTs, the Drivers Interface Box, the Motor Controller and the current sensor board, the hardware implementation for these boards will be dealt in other chapters.

For all the boards designed in-house, the PIC18F4480 microcontroller has been chosen as the protocol generator for three reasons, first the microcontroller itself has an in-built protocol generator and hence does not need a chip like the MCP 2515 to be able to communicate via CAN. Secondly, the PIC18F series IC is an 8-bit microcontroller with features like with a program memory of 16 kilo bytes (KB) or 8192 single-word instructions which was found to be adequate for the teams use. The node with the highest code length is the telemetry node 1. Thirdly, the PIC18 microcontroller feature 4 X PLLs (phased-locked looping) in their clock generation circuits, which makes it possible to generate internal clock rates of 40 MHz while using a 10 MHz external clock and the errors introduced by crystal drift and PLL jitter, are within the limits specified by the CAN 2.0 specification. This makes the PIC18 series microcontrollers a good fit for the team's needs (5).

The MCP2551 was adopted as the CAN transceiver. A CAN transceiver is tasked with the responsibility of converting the single-ended data stream from the protocol generator to a differential-signal for transmission over the bus, the transceiver also receives a differential-data stream and converts it to a single-ended data stream to be sent to the microcontroller.

The MCP2551 was chosen because of the following features it offers, it serves as a fault-tolerant device that acts as an interface between the protocol generator and the physical bus. The MCP2551 implements the ISO-11898-2 physical layer specification. It supports a 1 Mbps data rate and is suitable for 12 V/24V systems.



These boards also have an RS232 level shifter to allow for on-the-fly debugging, the boards use a MAX3232 level shifter. The RS232 standard is used because almost every desktop PC has the capability to communicate via this standard.

The required power for the protocol generator, the transceiver and the level shifter is provided on the board itself, the 12 V bus is stepped down to a 5 V on-board supply using a LM7805 voltage regulator IC.

On Gato del sol III's CAN nodes, dual in line packaging (DIP) was used for ease of replacement of destroyed ICs, in Gato del sol IV, surface mount technology (SMT) for all chips was embraced as failures on Gato del sol III's boards were infrequent to warrant the use of DIPs and this reduced the size of the board to half of the original size. CAD Eagle was used for schematic capture and board layout. The boards were manufactured by Advanced Circuits and were populated in-house.



**Figure 3** CAN Board (Gato del sol IV)

### **2.8.3 Software Implementation**

#### **Programming Style**

The code for the CAN boards has been written in ANSI C, the C18 compiler has been used to compile the C code into the PIC device instruction set and this code is assembled with Microchip's MPLAB environment. There is significant use of macros to make the code less error prone and easier to read and change.

1. ECANPoll.c
2. can\_isr.c
3. main.c
4. canid.def

## **Standardized Code**

The software on the boards uses software files provided by Microchip, like the ECAN module drivers, to reduce firmware development time, increase code efficiency and reduce probability of bugs in code. The definition of PIC18F4480 device registers are given in pic18f4480.h, the drivers for the on-board USART module and the on-board ECAN module are written in ECANPoll.h and usart.h.

The CAN IDs have been assigned keeping in mind the necessity to prioritize messages, error messages have high priority increasing the chances of an error message to be successfully transmitted (Appendix – CAN Identifiers).

The source file has been split-up into fragments, so that debugging and additions to the firmware later will be easy.

## **Compilers and Tools**

Various tools were used in building the firmware. ANSI C was the language of choice for firmware development, partly because of the author's familiarity and experience with developing software for various microcontrollers in C and also due to the availability of supporting drivers in C. MPLAB IDE was chosen to assemble all the code because it is an industry standard and is recommended by Microchip Inc.

## **2.9 Results**

The present CAN network had proven to be very reliable and efficient during the ASC2010. The CAN identifiers were assigned keeping in mind the priority of each message.

In the present system, error messages like (BPS faults – voltage and temperature and pack over-current faults from the current sensor) get priority over any other message.

A degree of fault tolerance has been included in the CAN firmware on all the boards, the software keeps track of the transmit error counter and the receive error counter registers, and if in case the register value is more than 200 an error message is generated.

After the Master BPS has issued the INITIATION\_SUCCESSFUL message, all the BPS boards initialize the registers for interrupt enable on CAN message reception, this software update guarantees that a message sent out will be received and necessary action taken immediately.

CAN is a broadcast based bus, all the nodes receive each and every message, this is very helpful when multiple nodes are required to process the message and take action, for example: before the Master BPS closes the P-MOSFETs (supplying 12 V to the Pre-charge and Main relays), it sends out an INITIALIZATION\_SUCCESSFUL packet, and all the nodes activate the interrupt service routines on receiving this single packet, but this messaging protocol is also considered to be information overload in every other scenario, for example: when the telemetry node is requesting data from a particular BPS, the other BPS boards do not have to receive this message and act upon it, so CAN software filters have been applied to incoming messages, this also leads to a decrease in power consumption.

## Chapter 3 Batteries and Battery Systems

### 3.1 Background

The demand for improvements in type and technology of batteries has increased exponentially over the past decade. The requirements of the batteries pertaining to the application that is the interest of this thesis are: rechargeability, high energy density, high C rate, long cycle life, high charge-discharge efficiency, wide operating range with respect to temperature, minimal self-discharge, good load characteristics, low internal resistance, no memory effects, fast charging, high safety, low cost, high reliability, environmentally friendly and good recyclability. The following tabulates the R&D history of batteries (8).

**Table 1 History of Battery R&D**

Year	Researcher (Country)	Description
1800	Volta	Invention of the battery
1859	Plante (France)	Invention of the Lead Acid battery
1899	Jungner (Sweden)	Invention of Nickel-Cadmium battery
1901	Edison (USA)	Invention of Nickel-Iron battery
1932	Schlecht& Ackermann (Germany)	Invention of sintered pole plate
1947	Neumann (France)	Successful sealing of Nickel Cadmium battery
1990	Sanyo (Japan)	Commercial Introduction of the Nickel Metal Hydride battery
1991	Sony (Japan)	First Commercial Introduction of the Li-Ion battery

### 3.2 Batteries

Batteries can mainly be categorized into two types based on whether they can be recharged or not, primary batteries are designed to convert chemical energy into electrical energy only once whereas secondary batteries which are reversible energy converters are designed for repeated charges and discharges.

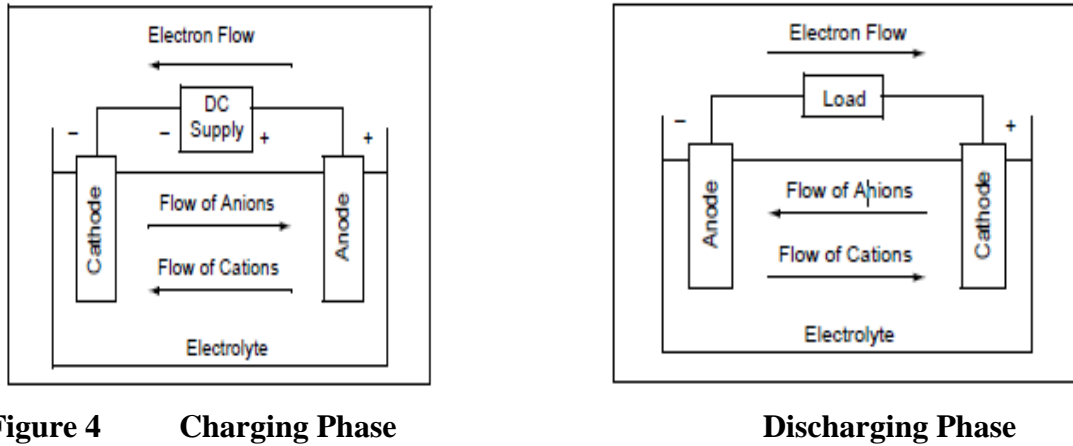

**Figure 4** Charging Phase

**Discharging Phase**

Electric and hybrid-electric vehicles (EVs and HEVs) typically use secondary batteries to store energy used later for propulsion and on-board power requirements. A few factors that affect the life or charge retention of these batteries are cell design, ambient temperature, length of usage and storage and battery chemistry (10).

The most common forms of secondary cells are sealed lead acid (SLA), nickel cadmium (NiCd), nickel metal-hydride (NiMH), lithium-ion (Li-Ion) and lithium polymer (Li-Po).

**Table 2** Comparison of Secondary Battery Characteristics

	NiCd	NiMH	Li-Ion	Li-Ion Polymer	SLA	Rechargeable Alkaline
Gravimetric Energy Density (Wh/kg)	30-60	50-90	90-115	100-110	20-40	20-85
Energy	90-150	160-310	200-280	200-250	70-90	250

Density (Wh/l)						
Self Discharge( %/month at 20°C)	10-20	20-30	5-10	1	4-8	0.2
Cycle Life	300-700	300-600	500-1000	200	200- 500	15-25
Temperature (°C)	-20-50	-20-50	-20-50	-20-50	-30-60	-30-50

### 3.2.1 Nickel Cadmium battery technology

Nickel Cadmium (NiCd) batteries have been traditionally used in power tools, but there are some drawbacks with this battery chemistry, firstly, the energy density and specific energy are relatively low. Secondly, they suffer from the memory effect, which is defined as the decline in effective capacity with repeated partial charge/discharge cycles. Eventually, as the partial cycling continues, the battery will be able to supply the capacity retrieved from partial cycling. Although the original capacity might not be restored, this condition can be reversed to a degree by performing multiple complete charge/discharge cycles. There are two reasons in literature for this memory effect, the first reason that experts argue is that the effect appears to be due to the growth of abnormally large crystals on the cadmium electrode, these crystals reduce the surface area of the electrode increasing the internal resistance and this causes the voltage drop during discharge (11). The major advantages when using this battery chemistry are, the batteries are sealed and therefore require little maintenance, they have long cycle life, a rapid recharge capability. The disadvantages with this chemistry though outweigh the advantages, this chemistry demonstrates memory effect under certain conditions, they have a relatively high self-discharge rate, due to the presence of cadmium in the chemistry it is highly toxic (10).

### 3.2.2 Nickel Metal Hydride battery technology

Nickel-Metal Hydride and Nickel Cadmium have similar chemistries, Sanyo Electric (Japan) commercialized the first NiMH battery in 1990. This chemistry offers

higher energy densities than NiCd and also offers the same operating voltage. In NiMH batteries a metal hydride (MH) has replaced the cadmium electrode, the positive electrode and the electrolyte are more or less the same (10).

The differences between the two chemistries are as follows.

- NiMH batteries have better energy densities than NiCd, this is due to the fact that the MH electrode has a higher energy density than the Cd electrode in NiCd batteries (10).
- NiMH batteries are less tolerant to overcharging, this requires that the charging algorithm to be more precise.
- NiMH batteries have a higher self-discharge rate

### **3.2.3 Sealed Lead Acid battery technology**

The sealed lead acid (SLA) battery has been in use for a long time, it still finds use in automotive applications where it is used for starting the engine and vehicle lighting. It still boasts of a market share of 40%-45% (10). SLA batteries are maintenance free and therefore do not require the electrolyte to be replaced. The positive electrode of a SLA battery is formed by lead dioxide ( $\text{PbO}_2$ ), while metallic lead (Pb) is used for the negative electrode. A sulphuric acid ( $\text{H}_2\text{SO}_4$ ) solution is used for the electrolyte. The operating voltage of a SLA cell is 2 V.

The advantages that come with using this battery chemistry are, it is a very popular low-cost secondary battery, it is electrically very efficient with a turnaround efficiency of 70%, the battery's SoC can be determined comparatively easily as it varies linearly with the voltage and the cell components of a SLA battery are easily recycled. The disadvantages though are, it has a low cycle life, low energy density, thermal runaway in some SLA's can lead to explosions and will degrade if stored for a long time in discharged condition (10).

### **3.2.4 Rechargeable Alkaline battery technology**

Batteries of this type were introduced by Renewal company in the USA in the year 1993. Zinc is used as the negative active material, manganese dioxide for the positive active material. The average operating voltage of an alkaline cell is 1.2 V. The rechargeable alkaline battery offers advantages like, low self-discharge rate and low-cost.

The disadvantages though are poor cycle life and low initial capacity. The initial capacity of the rechargeable alkaline battery at 20 °C is 70% of the capacity of a primary battery (8).

### **3.2.5 Lithium-Ion battery Technology**

The first Lithium Ion (Li-ion) battery was introduced by Sony (Japan) in 1991. Li-ion is comprised of a carbon anode and a lithiated cobalt dioxide or manganese dioxide cathode with a liquid or solid electrolyte separator. In the charging phase, lithium-ions de-intercalate from the cathode matrix and go across the electrolyte and intercalate into the carbon matrix. On discharging the reverse reaction takes place. The typical voltage bounds on these batteries are 4.2V on the top and 2.5V on the bottom. Cell demise can set in very quickly if the charge and discharge cycles are not controlled strictly. Overcharging leads to electrolyte oxidation and decomposition, while over discharging leads to structural changes to the cathode causing permanent damage (12). The electrolytes used in Li-ion batteries are non-aqueous, as opposed to aqueous electrolytes used in Ni-based batteries. A salt dissolved in an organic solvent serves as the electrolyte in Li-ion batteries. The advantages with using this battery chemistry are, they have a long cycle life, a very broad temperature range of operation, a rapid charge capability, high specific energy and energy density, they do not demonstrate memory effect, and they have low internal resistance. The disadvantages of using this battery chemistry are, it degrades at high temperatures, they can vent and possibly go into thermal runaway if overcharged or crushed, they require active protective circuitry. Lithium-ion Polymer (Li-Po) batteries were introduced as a successor of Li-ion battery, the electrolyte in a Li-Po cell is a solid ion conducting polymer material, the use of a polymer electrolyte offers the possibility of fast production of cells. The Li-Po cells can be built in various possible dimensions due to the way they are manufactured, this leads to an increase in energy density for a portable product (13). A technology still in development is a Li-based battery with the carbon negative electrode replaced by a metallic lithium electrode, called Li-metal batteries.

**Reasons for opting Lithium-based battery chemistry for the solar car's battery pack:**



Sealed lead acid (SLA) batteries are heavy and used in stationary applications and do not make the cut as viable means of energy storage for EV's based on the gravimetric energy density, which is the ratio of the energy output of a cell or battery to its weight.

The advantages with using Nickel cadmium batteries is that they can be charged quickly, they typically have high charge – discharge cycles, minimal self-discharge, they are forgiving if operated beyond manufacturer specifications and are economically priced. The disadvantages of using these batteries are, they have a relatively low gravimetric energy density, as was mentioned earlier they suffer from memory effect and are environment un-friendly.

On the other hand, nickel metal-hydride has 30 – 40% more capacity than standard nickel cadmium, they are less prone to memory effects and are environment friendly. The limitations with this technology are, these batteries typically have lower number of charge – discharge cycles, they have a very high rate of self – discharge and the performance degrades significantly when stored or operated at elevated temperatures.

The advantages with Lithium-based batteries are they have high energy densities with potential for improvement, relatively low self-discharge, they do not suffer from memory effect and can provide very high currents. The disadvantages to this technology though are, they require a protective circuit for safe operation, they are subject to aging even when not in use, there are transportation restrictions due to its volatility and are expensive to manufacture.

### **3.3 Battery Protection System**

#### **3.3.1 Definitions**

**Module:** The smallest easily removable group in a battery pack.

**String:** The smallest group of cells in a battery pack needed to provide the required voltage.

**Protection Limit:** The measured level determined to be adequate to protect the cell/module from an event.

**Active Protection:** System in which measurements are constantly monitored and appropriate action can be taken without operator intervention.

**Passive Protection:** Systems in which measurements are taken by the driver and actions are driver controlled.

The organizers limit the chemistries of batteries that can be used at the event, and based on the type of chemistry weight restrictions are imposed. Weight restrictions ensure that each team is on a level playing field with respect to the amount of energy a team can start a race with, in the battery pack.

**Table 3 Weight Limits – ASC 2010**

Sealed Lead-Acid	110 kg
NiMH	45 kg
LiFePO <sub>4</sub>	30 kg
Li-ion	25 kg
Li-Po	25 kg

### 3.3.2 Problem Statement

As the name suggest, a battery protection system works to protect the pack from operating in run-away conditions. Li-based batteries are known to be volatile in nature (see section 3.3.5), added to that, prismatic cells like the ones used in the solar car do not offer good protection in case the batteries start to vent. Due to the above mentioned reasons, the North American solar car challenge rules mandate the use of elaborate active battery protection systems for lithium battery chemistries.

The organizers of the solar car challenge make a distinction between two battery protection systems (BPS), called active and passive system. Li-based batteries are required to have active protection systems, and battery chemistries like Ni-based batteries, Lead-acid batteries are required to have passive battery protection systems.

The solar car team purchased battery protection systems for the earlier battery packs from another solar car team but due to lack of information and documentation of

the working of the purchased BPS boards, resolving issues with the boards was not possible, the decision was made to design the BPS boards in-house.

The operating principle of the BPS follows - if in case the BPS detects that a battery module / battery pack is not operating under conditions specified by the manufacturer (these conditions are replicated in BPS firmware), the system isolates the load from the pack, in this case, the BPS isolates the pack from the motor controller and the array. The BPS was originally designed for Gato del sol III by the NASC-2008 design team.

### **3.3.3 Battery-Pack Design**

The battery-pack constructed for ASC2010 event, was built to a nominal pack voltage of 103.6 V and an energy capacity of 5 kWh. The packs have been configured as 11 cells in parallel to form a module and 28 such modules in series to form the pack (28S11P) for Gato del sol IV and 7 cells in parallel to form a module and 28 such modules in series to form the pack (28S7P) in case of Gato del sol III.

This section of the thesis will highlight the lessons learned about battery-pack construction. The single point agenda in designing a battery-pack is to pack as much energy as possible to compensate for loss in power caused by shading or damage of cell/panels of the solar array.

The batteries procured for the ASC 2010 event were Lithium-Polymer (Li-Po) batteries with a nominal voltage of 3.7 V and a capacity of 4700 mAh from AA Portable Power Corp., the logic behind going with a pack that ultimately cost the team almost half the price of Gato del Sol III's pack was that, the team decided to use a new battery pack for every race attended. During the NASC 2008 event, the team invested in batteries with a nominal voltage of 3.7 V and a capacity of 7500 mAh from Dow Kokam.

A module as mentioned earlier has been constructed by stringing 11 cells in parallel for Gato del sol IV and 7 cells in parallel in Gato del sol III. Before stringing cells in parallel, the voltage of each cell was measured and matched against the value registered by the manufacturer before shipping it out to the team and both values recorded in an excel sheet, after 1 week the voltages of all the cells was measured again and recorded, this continued for 4 weeks, at the end of which a determination of each

cell's discharge profile was made, then the internal resistance of each cells was measured with an impedance analyzer, this data was sent to the Stanford solar car team who ran this data through a search algorithm (written by the Stanford solar car team) to determine which cells would best suit each other to form a module. This process is called *battery binning*.

This exercise proved to be worth all the time spent measuring and recording the voltages of 350 cells. During the ASC 2010 event, no substantial bad battery-module behavior was observed; all the cells were measured to be within 10 mV of each other.

### 3.3.4 Design Solution

#### Battery Protection System-Design (Hardware)

The microcontroller is at the heart of the intelligence of the system, it sends commands to the temperature measuring module and the voltage measuring modules and receives data from both the modules, the data is sent to the on-board A/D channels in the microcontroller for processing, after which the microcontroller sends control signals to the control module and it also sends data to the CAN module for transmission to off-board units. All the boards are similar in hardware capability, this procedure was followed to allow for the boards to be circulated among each other if the situation ever required any board swapping.

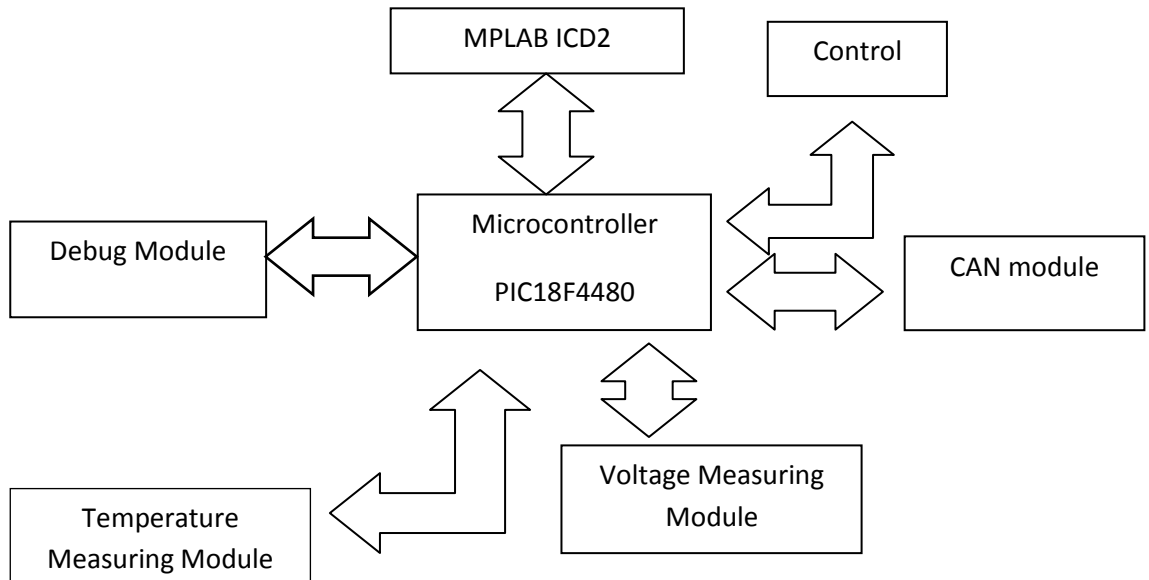

**Figure 5 BPS Schematic**

Voltage Measuring Module: This module encompasses, shifters, opto-couplers and capacitors that can switch among the seven modules to present the voltage of 1 module at a time, the microcontroller sends signals to this module to control the switching. To minimize the number of pins required to control the 28 opto-couplers that help in charging on-board capacitors to the battery module voltage and then discharge the capacitor into a centralized capacitor after which the signal is conditioned in an operational amplifier (LM324 – quad OP AMP) and then handed over to the PIC's A/D channel, shift registers are used. The microcontroller uses serial peripheral interface (SPI) to communicate with the shifters.

Temperature Measuring Module: This module contains an analog multiplexer that helps read the temperature of one battery module at a time. The temperatures are sensed using 5 k $\Omega$  thermistors which are excited using an on-board 4.5 V reference IC, which also provides the reference voltage to the A/D channel on the PIC. The control signals to the multiplexer are issued by the microcontroller. The voltage across the thermistor is read using a standard voltage divider network, where the thermistor is the lower leg of the divider. This signal is sent through the multiplexer to the second operational amplifier in the on-board LM324, which is then handed over to the PIC's second A/D channel.

CAN Module: The CAN module is a reproduction of the circuit on the CAN boards used by the solar car team, single-ended messages are sent to this module by the microcontroller which are then converted to a differential-ended signal which is then sent out on the CAN bus network.

Debug Module: To allow for in-circuit debugging, the board also includes hardware to read in the state of registers of the microcontroller, this helps the team pin point an issue as and when one crops up, this decreases down-time (time taken to get the car back on the road) dramatically.

MPLAB ICD 2: The MPLAB ICD2 (In-Circuit debugger) is a tool, which simplifies the code development and hardware debugging process. The ICD (In-circuit debugger) interface allows the PIC18F4480 device to be reprogrammed after the board has been manufactured and populated, via a RJ11 connector. This allows software changes to be

updated easily. Surface mount technology has been embraced, this has caused the PCB size to shrink dramatically.

Control Module: The Control Module encompasses two P-channel MOSFETs and the SN7407 buffers which based on the signals from the microcontroller drive the FET's gate.

## **Battery Protection System-Design (Software)**

### Programming Style

The code for the BPS boards has been written in ANSI C, C 18 was chosen as the compiler for this project because of the availability of libraries for the PIC's on-board CAN, USART and A/D converter modules, the C 18 compiles the code into the PIC device instruction set and the code was assembled in the Microchip's MPLAB environment. Macros have been extensively used to make the code easier to read and tweak. The source files are fragmented as follows:

1. ECANPoll.c
2. can\_isr.c
3. main.c
4. canid.def
5. start\_up\_bps.c
6. measure\_v\_t.c

Some of the files are standard on all the controllers, like ECANPoll.c, main.c, the other files differ based on the functionality of the board, this is easily determined by reading the code.

The analog channels are sampled 1024 times before the reading is evaluated to increase the resolution of the 10-bit A/D channel via software (7).

### **Organization**

As has been mentioned earlier, each BPS board monitors the voltages and temperatures of 7 battery modules, which in-turn requires all of the team's battery packs to include four such boards, out of the four boards, one board to nominated as the Master

BPS, because this board will control the Pre-Charge and Main-Relays of the car via 2 P-channel MOSFETs.

The hardware and software updates including mounting resistors to the board instead of wire taps from batteries and using interrupt service routines for CAN messages proved successful in improving system performance from the FSGP2009 event.



**Figure 6 BPS Boards (Gato del sol III and Gato del sol IV)**

### **3.3.5 Battery Balancing Systems-Problem Statement**

Gato del sol I, II and III did not include a charge (battery) balancing system; the absence of this system was determined to be the cause of Gato del sol III not being able to perform better than it did in NASC2008.

A research paper claims that “Research leading to the determination of an optimum battery pack management strategy is probably the single most important technical issue in the successful commercialization of EVs” (15). With the advent of environment friendly electric vehicle technology, now the prospect of the EV replacing the internal combustion engine (ICE) looks promising. With the sudden rise in interest in this technology, electric vehicle manufacturers are pushing forward to bring this technology on-par with that of the ICE. The average automobile runs as far as 300 miles on one tank of fuel, so manufacturers are increasingly trying to make sure that the EV matches the ICE on distance travelled on a single charge.

To provide the high voltage and power requirements of an automobile, battery packs are constructed by placing cells in various series and parallel combinations.

As has been mentioned earlier, the solar car has battery-packs with 28S11P/28S7P configuration.

Batteries are nearly always used in series combinations of multiple cells, when a series string of cells is charged as a group, a single current is imposed on all cells. However, if voltages begin to differ, the result is a charge imbalance and this can lead to pack failure.

In multi-cell packs, it is commonly noticed that the behavior of individual cells tends to drift away from each other as time progresses due to factors which can be categorized into: internal and external factors.

Noticeable internal factors that cause such deviations in cell behavior are, variance in physical volume, variance in internal impedance and variance in rate of self-discharge, these variations occur because manufacturers typically have an error of 3%, variance can also set in due to different rates of cell degradation and deviant cell behaviors have been noticed when there is a significant temperature gradient across the battery pack (16).

In multi-cell battery packs, any imbalance in the cells leads to:

- Reduced capacity: The capacity of the pack is greatly reduced because during charge and discharge cycles, the cell with the lowest capacity typically has greater voltage swings, and the charger will stop prematurely if it detects that one cell has topped off.
- Reduced pack life: Operating an imbalanced pack for a few cycles can greatly diminish the pack life, and can cause cascading effects on the other cells too.
- Cell Damage: If the charge monitor keeps in check only the pack voltage and not individual cell voltage, the bad cell can be caused to go into overcharge which can cause it to vent.

Cells with reduced capacity or higher internal impedance tend to have large voltage swings when charging and discharging (17). A battery pack is as strong as the weakest cell, due to the reduced capacity in a degraded cell, the cell tends to charge up and discharge a lot earlier than the average time taken to discharge and charge a cell within the same battery pack.

Although cell balancing cannot recover battery pack capacity lost due to internal factors, any imbalance introduced due to external factors can be rectified, hence increasing the battery pack life.



The solar car team in the past has experienced problems with an unbalanced pack, the first problem the team encountered in the NASC 2008 event was that during charging, a bad cell would charge up to its cut-off voltage before the average voltage could rise substantially, but because the BPS will isolate the battery pack from the solar array if it finds that a battery module has reached the voltage bounds, the pack would not be optimally charged. The other problem the team faced was when the pack was on the discharge profile, a degraded cell would tend to fall down the discharge curve earlier than the average, hence forcing the BPS to isolate the pack from the motor and sending the car into fail safe mode. During the NASC2008 an erroneous shut down of the car due to a bad module during charging was rectified by placing a high-power 5Ω resistor across the battery to dissipate power till such a time when the average pack voltage had risen substantially, and if the shutdown was due to a bad cell bottoming out on its voltage profile, the car would be pulled to the side of the road and charged till such a time when this erroneous cell charged up substantially.

The race organizers allows every team to swap out battery modules, but each replacement brings with it heavy time penalties which are added to the team's final time and replacement of a module does not necessarily correct the problem, because the module that is replacing the bad-module is not at the average SoC of the battery pack.

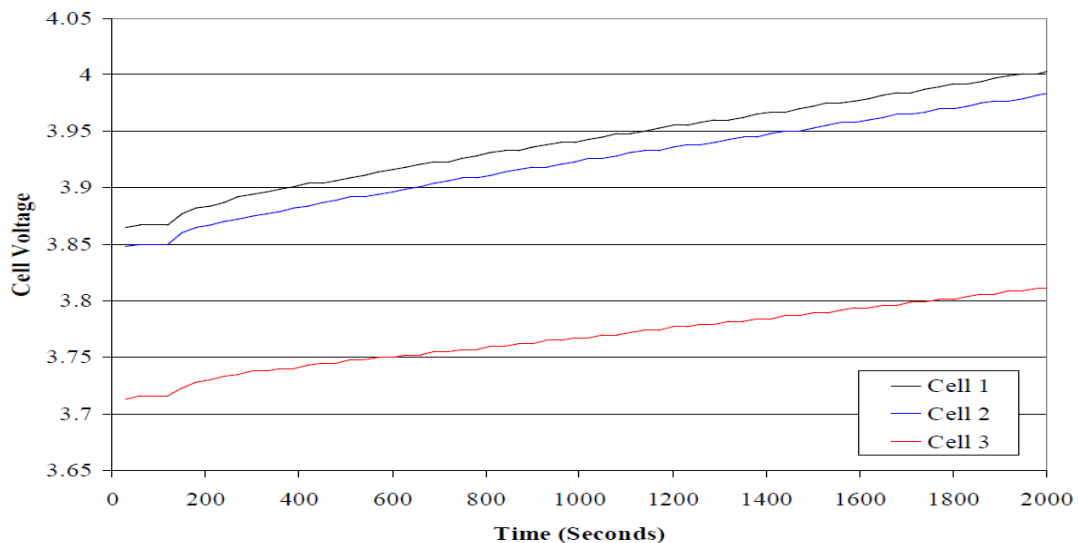

**Figure 7 An Unbalanced Pack**

### 3.3.6 Estimation of State of Charge

Automobile users are accustomed to looking at a fuel gauge and determining how much longer they can drive with the amount of fuel in the tank. In HEV technology, there are two reasons to determine the State of Charge (SoC), the first motivation in estimating this quantity is the same function of a fuel gauge in an ICE, the second motivation is because unless the SoC of a cell is compared against the average SoC of the battery pack, a determination of whether the cell in question is bad or not cannot be made. Quantifying this quantity is further complicated by the fact that the SoC of a battery is also dependent on the temperature, battery capacitance and internal resistance. In literature many methods have been described and tested for the precise evaluation of the SoC of lithium based battery chemistries, one is to perform an operation called coulomb counting, which means solving equation 1, here the battery is assumed to be fully charged initially ( $t_0$ ),  $Q_0$  is the total charge the battery can hold or deliver,  $I_b(t)$  is the discharging current, SoC is typically reported as a fraction of the cell capacity.

$$S(t) \triangleq \frac{Q_0 - \int_{t_0}^t I_b(\tau) d\tau}{Q_0} \times 100.$$

#### **Equation      Coulomb Counting**

The second strategy is to compute the open-circuit voltage of the cell and determine the SoC based on that voltage, this methods works based on the concept that the SoC changes linearly (approximately) with battery open-circuit voltage (18).

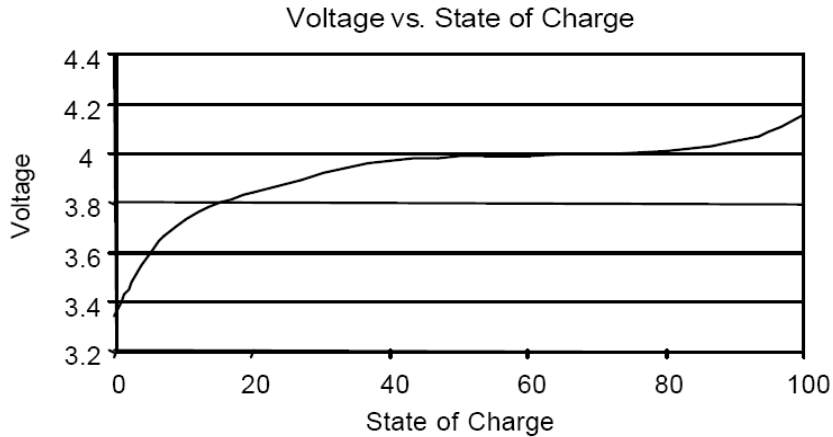

Open Cell Voltage of Lithium Polymer Battery

**Figure 8 Voltage vs. SoC (Typical Li-Po cell)**

### 3.3.7 Charging Algorithms

A lot of research has been conducted on improving present charging algorithms and implementing new ones, the advent of switching mode power supplies (SMPS) has led to well regulated charging profiles pushing batteries to achieve high performance figures. Some of the basic charging profiles are mentioned below and discussed (19).

Constant current Constant voltage: A simple charging profile which features a current limit and then a voltage limit, the CCCV profile is further enhanced with the use of a cut-off function. This method is used for effectively fast-charging sealed lead-acid (SLA) batteries.

Trickle Charging: The practice of keeping a storage battery ready for use by means of continuous long term constant voltage, limited current charging regime.

Pulse Trickle Charging: For battery technologies that are less thermally stable, or for batteries that being fast-charged a pulse type trickle charging is preferred, this algorithm is run typically at the end of the normal constant voltage charging algorithm.

Lithium polymer batteries are ideally to be subjected to CCCV charging algorithm, the battery manufacturers datasheets suggest that the shut-off feature during the CV phase should be initiated either by starting a timer at the beginning of the CV stage and terminated as soon as time limit expires or the other strategy is using the amount of current being pumped into the battery pack during the CV stage to determine

the point of shut-off, the percentage of this current (based on the C-rate) varies with the manufacturer.

### **3.3.8 Balancing Circuits-A Review**

With the rising demand for a battery pack to be able to run for as long a conventional drive automobile can drive on a single tank of fuel, the EV/HEV should be able to use as much capacity as possible that the pack has to offer.

To be able to tap into the full capacity of a battery, it follows from the earlier section that precise determination of SoC is required.

A battery pack is as strong as the weakest cell in the pack, to support such a weak cell, there are circuits designed, developed and analyzed in literature, while going through the literature and talking to top solar car teams around the world, a clear demarcation starts to form on types of balancing mechanisms. The two types of balancing mechanisms in use these days are, a passive system where a module containing the weak cell is discharged through a resistive element thus giving the entire pack enough time to charge-up substantially while giving itself enough headroom so that the weak cell does not begin venting. The second strategy is called active balancing, where excessive charge from a battery is taken and either distributed among other batteries or directed to one single cell to pull it away from bottoming out into permanent damage.

Cell-to-Cell imbalances in battery pack chemistries like lead-acids are traditionally corrected by over-charging, whereas in battery packs based on Lithium cells, over-charging can lead to venting and eventually the cells can catch fire. Manufacturers and the race organizers of the American Solar Car challenge strictly forbid teams from using any over-charging with lithium based battery packs.

There are several articles in literature based on active and passive battery balancing philosophies. Some of them have been mentioned in this thesis. Some papers make a distinction between, balancing mechanisms for EVs and HEVs, electric vehicle battery packs tend to be charged completely after every use, so an EV is a favorable scenario to implement end-of-charge balancing schemes, whereas in HEVs the battery pack may not be charged completely after every use, therefore making the state of the battery pack unpredictable. HEV batteries also require both high power charge and discharge capabilities, therefore they are maintained at a SoC which leaves enough power

in the pack to discharge the required amount and also enough headroom to accept power during regenerative braking. In this thesis the solar car has been considered to be a HEV.

### 3.3.8.1 Passive Balancing

In passive balancing schemes, balancing takes place by discharging a battery with excess charge through a resistive element till its SoC matches the packs average SoC. Although this means throwing away power and will take longer time to charge a pack to full capacity. The advantages to this system are it is easier to implement and it increases battery pack life. The disadvantages though are the all-important power is dissipated and because the power is dissipated through a resistive element, if not designed carefully the resulting temperature build-up can actually increase the probability of the pack going into thermal run-away.

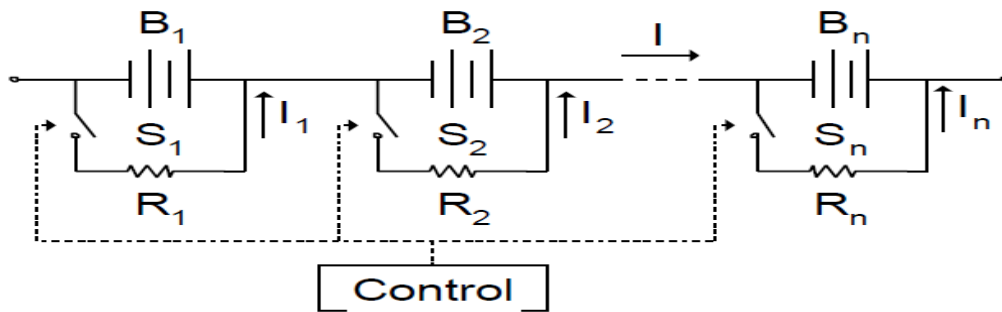

**Figure 9** Passive Balancing (17)

The effectiveness of this balancing scheme can be improved by using adaptive and learning control algorithms. The advantages of this system are relatively low complexity to implement and a simple algorithm, the disadvantages are, if not implemented properly it can cause enormous heat build-up and increased pack charging time.

### 3.3.8.2 Active Balancing

In active balancing schemes, balancing takes place by moving charge from an excessively charged cell to cells that are on the lower end of the SoC. Active cell-balancing methods employ an active charge-shuttling element or voltage or current converters to move energy from one cell to another.

The two types of active cell balancing are, *Charge Shuttling* and *Energy Converting*(11).

## Charge Shuttling

Charge shuttling cell-balancing mechanisms consist of a device that removes charge from selected cells, stores that charge and delivers it to another selected cell. There are several interpretations of this concept, the most notable being the *flying capacitor*.

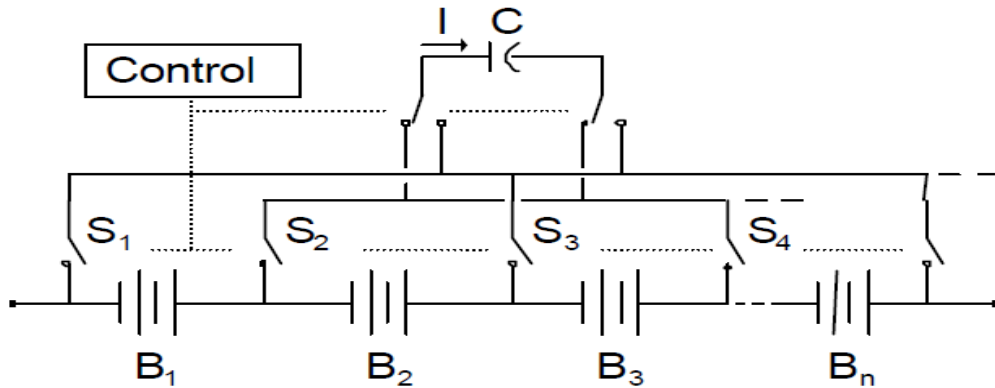

**Figure 10 Flying Capacitor (17)**

Here the control electronics close the appropriate switches to charge up the capacitor to the battery voltage, then the control electronics open those switches and close another set of switches to transfer the charge to a battery, the charge transferred will be equal to the difference in SoC's of the batteries in question. There are variations to this basic design, one is to select cells with the highest SoC difference, and then work downward, this would decrease the time taken to balance the pack.. Another balancing scheme shares a 'flying capacitor' for every two cells, the other modification is using a hierarchical structure of capacitors to transfer charge across the battery pack

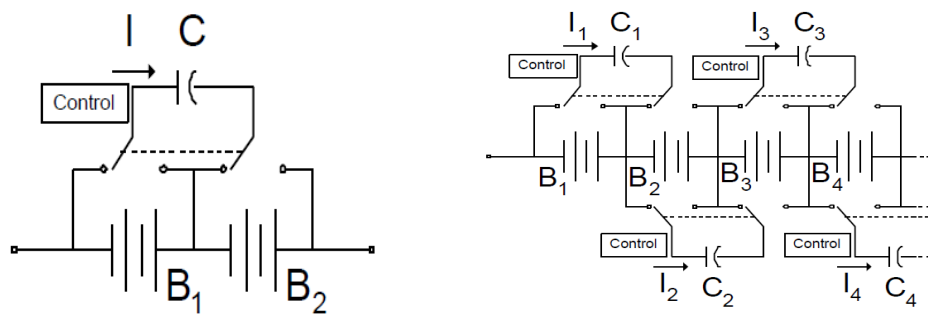
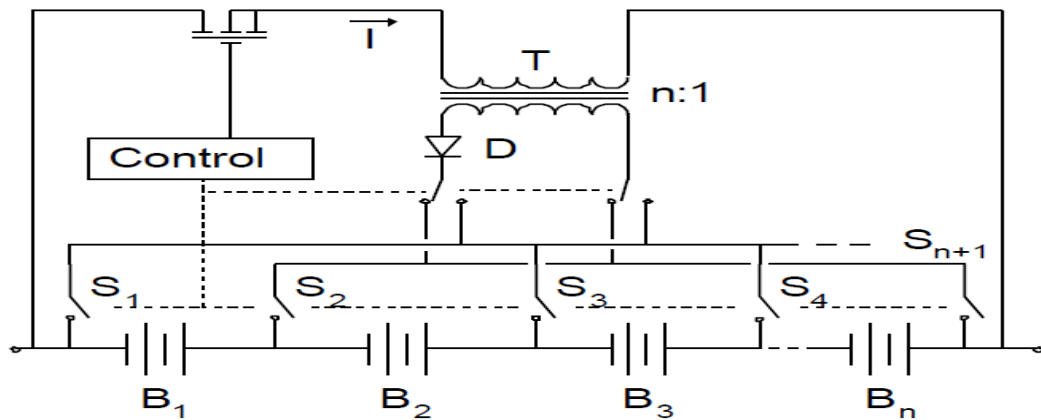

**Figure 11 Derivations of the Flying Capacitor Model (17)**

Charge shuttling techniques are of limited use in HEV applications using lithium based battery packs because the chemistry offers a very flat open cell terminal voltage across a very broad range of SoC. On the other hand because an EVs pack is fully charged after every use and the differential between a cell that is completely charged and the cell that is not will be greater near the ends of the curve, which increases the effectiveness of the technique.

Energy Converting

Cell balancing techniques using the energy converting technique employ inductors or transformers to move energy from one cell to another. Two types of active energy converting schemes are *switched transformer* and the *shared transformer* scheme. The switched transformer is very much like the flying capacitor balancing scheme

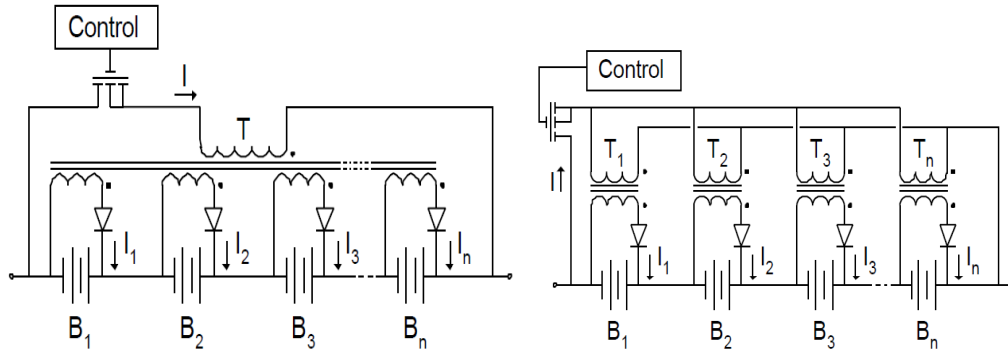

**Figure 12** Switched Transformer (17)

Current is taken from the pack, and then switched into the transformer T, the output is rectified and based on the setting of the switches is directed to the selected battery, the position of the switches is determined by electronic control.

The second energy converting scheme is called the shared transformer model. A shared transformer has a shared primary winding and secondary winding taps for each battery module. In this design, current is switched into the primary winding and induces current in each of the secondaries, The secondary with the least reactance due to low terminal voltage will have the highest induced current, therefore a cell receives current inversely proportional to its SoC. The advantages with this design are, it can balance a

multi-cell pack quickly, the disadvantages include complex magnetics, high parts count – the design will require an equal number of secondary windings as batteries and a rectifier for each winding/battery, expanding the system is not accomplished easily. The active component in the shared transformer is the switching transistor on the primary side. A variation of this model is the multiple transformer model,



**Figure 13 Energy Converting Designs**

The multiple transformer model is an extension to the operating concept of the shared transformer model, but without the disadvantage of not being able to add modules easily.

### 3.3.9 Strategy-Battery Balancing design Charge Balancing System–Design (Hardware)

An experimental strategy was adopted for ASC2010; this was based on inputs from discussions with previous team members and team members from around the world.

The strategy was to employ a passive charge balancing scheme on a battery pack that was built after an elaborate battery binning process (see section on Battery Pack Design).

Passive Balancing was adopted as a strategy to balance SoC mismatch in the battery pack because it was estimated that the deviation of modules from the average SoC over the race period would not be more than 2% which made the active balancing system a less preferable alternative to the passive balancing system.

In an active balancing system, a significant amount power is required to operate the control electronics, this extra power consumed by the control electronics is estimated



to be more than the power differential gained from a balanced battery pack to an unbalanced battery pack. The energy expenditure model does not work out in favor of the active balancing system.

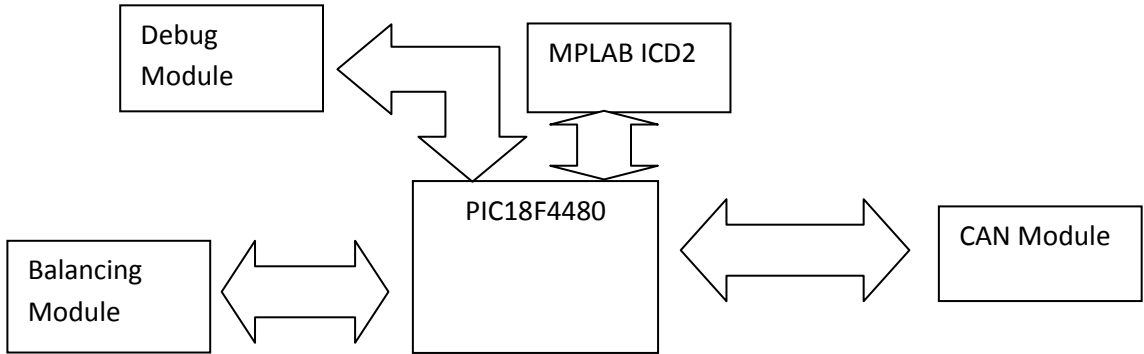

**Figure 14 CBS Schematic**

The Charge Balancing system (CBS) was designed to be compatible with the BPS system to allow for seamless integration. To maintain consistency, at the heart of the intelligence in this board is the PIC18F4480 microcontroller, this board receives commands from the BPS module to turn on or turn off the balancing module for a particular battery module.

This system was designed to be able to balance the pack by passive balancing mechanism, in order to maintain consistency, again each board houses balancing circuitry for 7 battery modules, the boards use  $5\Omega$ , 5 W resistors to balance the modules.

Balancing Module: The balancing module encompasses the balancing circuit, which consists of a high power resistor, an N-channel MOSFET and an opto-coupler.

CAN Module: Single-ended messages are sent to this module by the microcontroller which are then converted to a differential-ended signals which is then sent out on the CAN bus network.

Debug Module: To allow for in-circuit debugging, and debugging while on the road, the board also includes hardware to read in the state of registers of the microcontroller, this helps the team pin point an issue as and when one crops up, this decreases down-time dramatically.

MPLAB ICD 2: The MPLAB ICD2 (In-Circuit debugger) is a tool, which simplifies the code development and hardware debugging process. The ICD interface allows the PIC18F4480 device to be reprogrammed after the board has been manufactured and populated, via a RJ11 connector. This allows software changes to be updated easily.

Surface mount technology has been embraced, this has caused the PCB size to shrink dramatically.

### **Charge Balancing System-Design (Software)**

The boards were bench tested and functionality evaluation was found to be successful.



**Figure 15 CBS**

### **Previous Charge Balancing System Designs**

During the fall 2009 semester, an attempt at designing an active charge balancing circuit was made, the design was based on the flying-capacitor model, but the design was not pursued because it was not considered a viable system, owing to the amount of time it took to balance a module and the cost involved in developing the system. The estimated cost of developing such a system for the solar car was \$1,432.07.

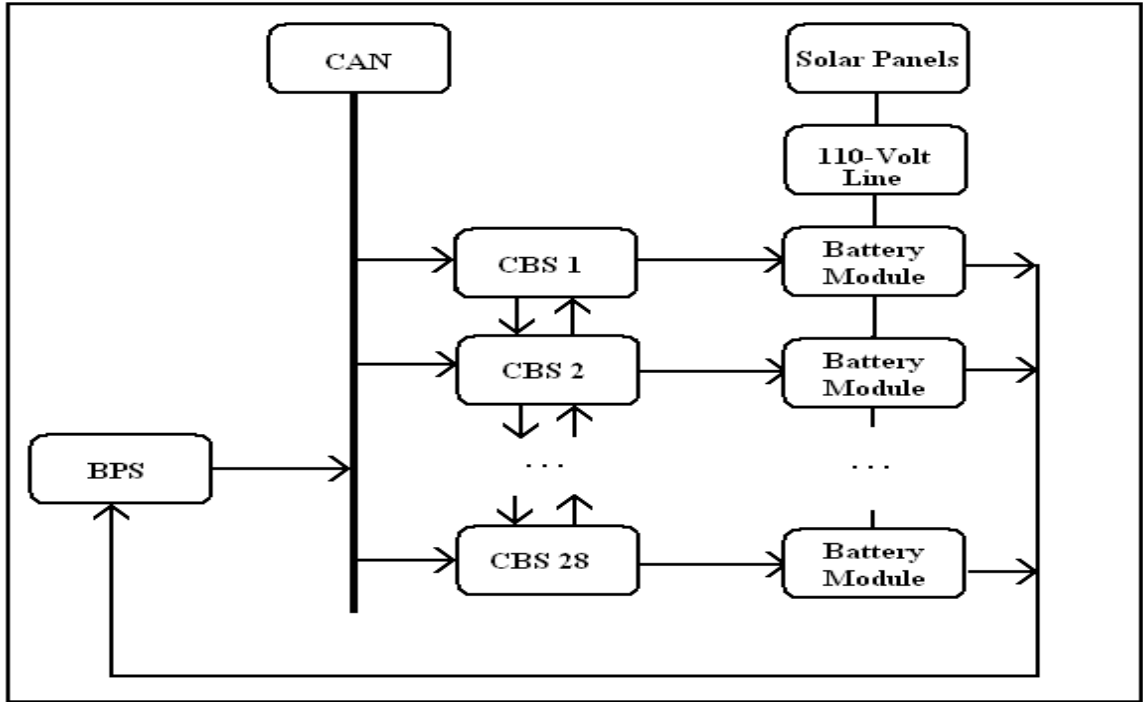

**Figure 16 Active Charge Balancing System-Block Diagram**

### 3.4 Results

During the NASC2008 event, the team faced hardships due to a highly unbalanced pack. During the development of Gato del sol IV and after the ASC 2010 event the battery pack (constructed before the event) was observed closely- no substantial divergence of battery behavior was observed in the battery-pack, the voltages were within +10 mV and -10 mV, voltage readouts of the BPS have an inherent error of 0.5%-1%, therefore none of the modules were replaced. The batteries purchased for NASC2008 event were of better quality, it is now determined that the issues faced during the NASC2008 event were related to a hurried construction of the battery pack, which meant that the cells were not properly binned in the first place and when the pack was put together, the modules would have started to deteriorate very quickly. This type of imbalance is called Capacity/Energy (C/E) mismatch and occurs when cells with different initial capacities are put in the same module. The second plausible cause for the balance of the pack to be disturbed is the method opted to put the modules together, seven modules were put together in a module by connecting each tab of the cells in a module via a copper bus bar, this design turned out to be extremely brittle and failed when mounted in the car (and driving) due to vibration, which lead the batteries to

experience excessive resistance which in-turn lead to a highly unbalanced pack. This led to a SoC mismatch over a period of time.

A new experimental method to construct battery modules was adopted which involved using double-sided printed circuit boards (PCBs) instead of copper tabs, the reason behind doing this was that PCBs are less expensive and are more flexible, the positive and negative leads on each cell were cut before putting it into a module so that the individual cells would not experience much play in the event of vibration, and the result was positive. After returning from the race, the team noticed that some of the batteries eventually vented (some team members noticed a strong characteristic smell of venting), this is attributed to the vibration the batteries experienced and the other reason could be the many incidents when building the battery pack where a few cells were inadvertently shorted briefly.

During the NASC2008 event the team resorted to using a 12V-5V DC-DC converter to rejuvenate cells that were discharging too quickly while driving and placed a high-power resistor against the bad battery module that was charging up very quickly to create enough head-room for normal pack charging. Even with this battery balancing strategy in place, the team was required to pull-off the road on multiple occasions and wait until the bad module was corrected using the above mentioned procedures, this cost the team a better finishing position (11<sup>th</sup> out of 14 teams).

The power dissipated through the resistors in the Charge Balancing System is 3.5W at full charge (4.2V). The reasons for adopting a passive balancing system are three-fold.

- a. From discussions with various teams and from experience from past races, the average SoC imbalance witnessed in a battery pack is estimated to be about 5% over the race (without battery-binning).
- b. The active charge balancing system designed by the senior design team (Previous Charge Balancing System Designs) took 4 hours to correct a 5% imbalance in the battery pack, this amount of time was unacceptable because the by the race rules each team is allowed to charge the battery pack for a maximum of 2 hours outside of racing time. The microcontroller was run at 40

MHz (increased switching speed) to try and decrease the balancing time, this led to increased power consumption.

- c. The power expenditure of running an active system far exceeds the advantage gained by using such a system in the event of a 5% SoC imbalance.

### **Bench Testing**

The Charge Balancing System was bench tested using a power supply and a fully charged Li-Po cell (4.2V).

- a. Time Taken to discharge to 3.8V (Li-Po cell): ~1 hour
- b. Temperature: 40 °C (ambient temperature: 25 °C, BPS Temperature cut-off – 60 °C)

Both parameters are found to be within the limits specified by the solar car team.

Commercial Battery Management Systems (BMS): After the race while conducting some additional research, the author found out that integrated circuit manufacturers are in the process of releasing IC's into the market which have the capability to monitor the voltage and temperatures and also have on-board hardware to balance cells, the balancing strategy adopted was typically passive (13).

## Chapter 4 Photovoltaic Array and Power Point Tracking

### 4.1 Definitions

**Solar cell:** A physical entity which generates an E.M.F when light is incident upon it.

**Open-Circuit Voltage:** abbreviated as  $V_{OC}$ , it is the potential difference across the junction of a solar cell when it is not connected to a load.

**Short-Circuit Current:** abbreviated as  $I_{SC}$ , it the current that is seen when the two terminals of the solar cell are shorted together.

**Solar-Cell efficiency:** A solar cell's efficiency is determined by its capability to convert incident sunlight into E.M.F. This term is calculated using the maximum power point (MPP) divided by the input light irradiance ( $E$ ,  $W/m^2$ ) multiplied by the surface area ( $A_c$ ).

$$P_m / E * A_c$$

The solar car race mandates that the battery pack should be charged and the motor should be powered only using solar radiation once the race starts.

In a photo voltaic system, solar arrays are formed by combining single solar cells in series to achieve the desired voltage and shall henceforth be called *strings* and more of such strings are added in parallel to achieve the desired current, this setup shall henceforth be called *panel* or a *module*.

To drive a typical solar-powered car, a considerable amount of power is required. The race rules require every team to have a limited area of the car covered with solar cells based on the solar cell technology.

For GATO I through GATO III the car was powered with mono-crystalline and poly-crystalline Silicon (Si) solar cells, which had an efficiency of 17%, for this technology, the event limits the area covered by cells to  $9\text{ m}^2$  which depending on the quality of cells equates to a power output of about 1.3 kW – 1.5 kW, GATO IV is powered with advanced triple junction gallium arsenide (GaAs) solar cells which have an efficiency of 28 %, for this technology, the event limits the area covered by solar cells to  $6\text{m}^2$ , again depending on the cells equates to an average power output of 1.5 kW. This is

done to level-out the playing field, that said depending on the budget of the team and the expertise with related technologies like encapsulation and solar cell concentrators, there are teams which can generate considerably a lot more (example: The University of Michigan Solar car team won the best array award, the *Infinium's* array is a GaAs array and it produced a peak power of 1.8 kW).

#### **4.2 Solar-Cell Array Design-Problem Statement**

Gato del sol III had a mono-crystalline Si solar array which produced a peak output power of 1.2 kW; this was enough to propel the car to 25 mph (break-even). The energy losses in the car were primarily attributed to aerodynamic resistance, rolling friction and un-aligned steering wheels.

After the NASC2008 event, many solar cells were found damaged – During the FSGP2009 event the peak power produced was 0.9 kW.

Improving the aerodynamics and increasing the power output called for construction of a new solar array, because removal of the modules on Gato del sol III to be transferred on to Gato del sol IV would have damaged them and caused further decrease in peak power output.

For the ASC2010 event, the decision was made to construct a GaAs solar array, to provide for a boost in peak power.

The first hurdle encountered when assembling a solar array was the sheer number of variables involved with construction, the issues that the solar car team ran into were, the voltage rating of the array, the current produced under full illumination, the contour of the upper body, the shape and size of each solar cell and the solar car's power requirements.

The car is shaped to be able to slip through the air without disturbing it too much, from initial CFD analysis, the car's drag has been determined to be about 0.09. To be able to accommodate the 27 degree seating angle as mandated by the race rules, the car's upper body had to be contoured to account for this.

Silicon solar cells have very little tolerance to bending moment along any direction due to the shape in which the mono-crystalline silicon (Si) cells are manufactured, whereas gallium arsenide (GaAs) solar cells can tolerate some amount of bending moment along the lateral axis of the each cell, that said, while designing the array for a solar cell, the bending moment on each sub-array must also be take into account, because the sub-array in itself depending on the type and quality of encapsulation can have varying degrees of tolerance to bending moments. The bending moments apart from being dependent on individual cells orientation and the moment along that orientation also depends on the size of the module and the location of the module on the shell.

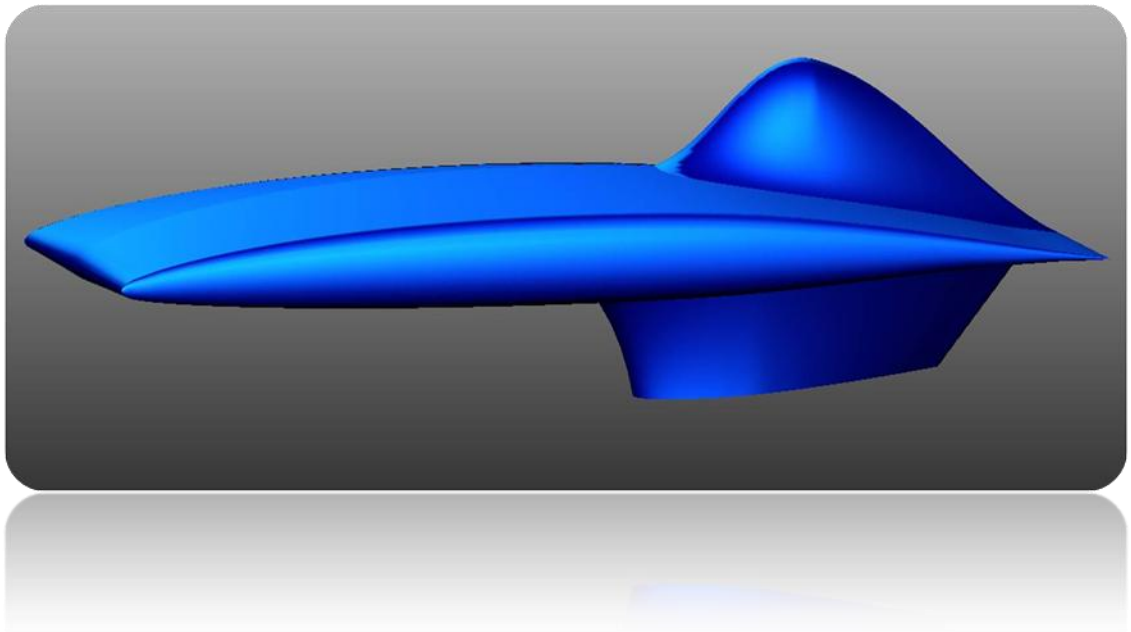

**Figure 17 Gato del sol IV top shell**

With the array of Gato del sol IV, the team made it a point to try and as far as possible limit the bending moment on all sub arrays, and in areas where it was unavoidable, the team limited the size of the module, so as the change in gradient is very gradual on every section of the car the moment experienced by smaller modules is well within their tolerance.





**Figure 18** Gato del sol III top shell

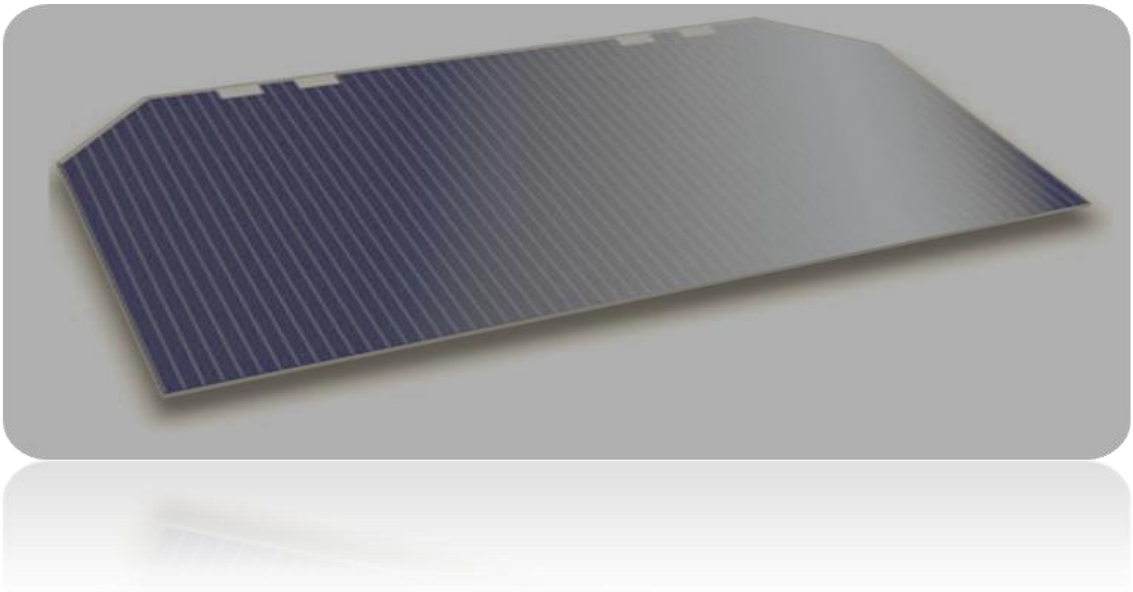

**Figure 19** A GaAs solar cell

Another pertinent issue to deal with when designing solar cell arrays is the coating of solar cell modules, to keep the solar cell surface free from abrasions, dust and water which drop the efficiency of the cell in the former two cases and can short a cell in the third case, the modules are encapsulated in a transparent material.

For terrestrial applications where weight of the PV array is of not much concern, a glass coating can be used because glass is more scratch resistant than polymer coating. In case of solar cars, glass is prohibitively heavy to be considered for use and therefore polymer coating like tedlar, tefzel, Lexan and epoxy have all been used over the years (23). The encapsulation for Gato del sol IV's array was outsourced to a company located in Arizona.

Since coating has been applied to solar cell modules, teams have been researching the effect of coating on the amount of sunlight incident on the solar cell, due to change in refractive index from air to the material used to coat, most of the light gets reflected without ever impinging on the cell. Teams have experimented with different materials and there are a few improvements to the original coating schemes.

The first improvement suggested is *anti-reflective coatings* (ARC) and the second improvement is *texturing*.

The single point agenda of solar car racing is to finish the challenge by using the power of the sun to drive the entire 2000 km (ASC 2010) or the entire 3000 km (WSC 2009). The ideal situation is to use the solar array for most of the driving (called break-even), and for sections of the road where it is rather mountainous or in stop and go traffic, or in regions where we encounter brief periods of array shading, the power from the solar array is to be supplemented by power provided by the battery pack.

To localize effects like shading or a cracked cell, the array is typically divided into sub arrays, each sub array matched by voltage, to match the voltage, cells are added in series and depending on the area available and issues like bending moment on each cell and each module, number of such series-strung cells are added in parallel to generate the maximum possible amount of current from the sub array. All teams are allowed to use a limited number of cells on the car, the limitation is imposed by restricting the area covered by solar cells, the maximum area to be allowed is determined by the solar cell technology, the average cost involved and recently, the achieved top speed (WSC organizers are now limiting teams which use GaAs solar cells to 3 m<sup>2</sup> a 50% drop from

last event's 6 m<sup>2</sup> – this amendment was made to reduce the top speeds, because the average speeds of the top teams during the WSC2009 event were deemed unsafe).

The factors that go into designing a solar array also include, the number of sub arrays which equates to the number of maximum power point trackers (MPPT) on the car. GATO III silicon array was divided into four quadrants equating to four MPPTs, GATO IV's array was divided into eight quadrants equating to eight MPPT's.

The MPPT's were sourced from DriveTek AG (Switzerland) for both Gato del sol III and Gato del sol IV.

### **4.3 Power Point Tracker-Problem Statement**

In an electromechanical system consisting of a solar cell array, a DC motor and a mechanical load, the operating point is determined by parameters like the V-I characteristics of the solar cell, the motor type and the torque-speed characteristics and their relationship to the mechanical load.

The operating point of the PV-array in an electromechanical system is determined by where the load line intersects the I-V curve of the PV array at that time. From the graph below, it can be observed that this point is not the maximum power point (MPP) of the array, because of this problem, in directly-coupled systems the array is often oversized to compensate for loss in power.

In a power sensitive application like the solar car, where the maximum area of the car covered with solar cells is limited by the race organizers, and every gram of unnecessary weight added to the car is deemed inefficient car design, a system that makes the PV-array operate at the MPP is an indispensable tool. In case of solar cells, the area under the I-V curve is the power generated by the array and from direct observation of the curve it can be determined that the maximum power point is at the knee of the curve.

Solar cells are used in many terrestrial, space and power generation applications. For the solar array to generate the maximum power possible, it has to operate at its maximum power point (MPP), depending on the solar cell technology, a solar cell's

operating point is influenced by illumination, temperature, radiation dose and other ageing effects.

An MPPT is different from a mechanical tracker, which tracks the sun and attempts to position the array perpendicular to the sun arrays to expose maximum possible area to the sun's rays incident angle, a maximum power point tracker keeps a module operating at the knee of the I-V curve.

#### 4.4 Working of an MPPT

An MPPT is typically made up of a DC-DC boost-converter, a programmable current oscillator and controller implementing the tracking algorithm (on-board intelligence).

A generic block diagram is given below.

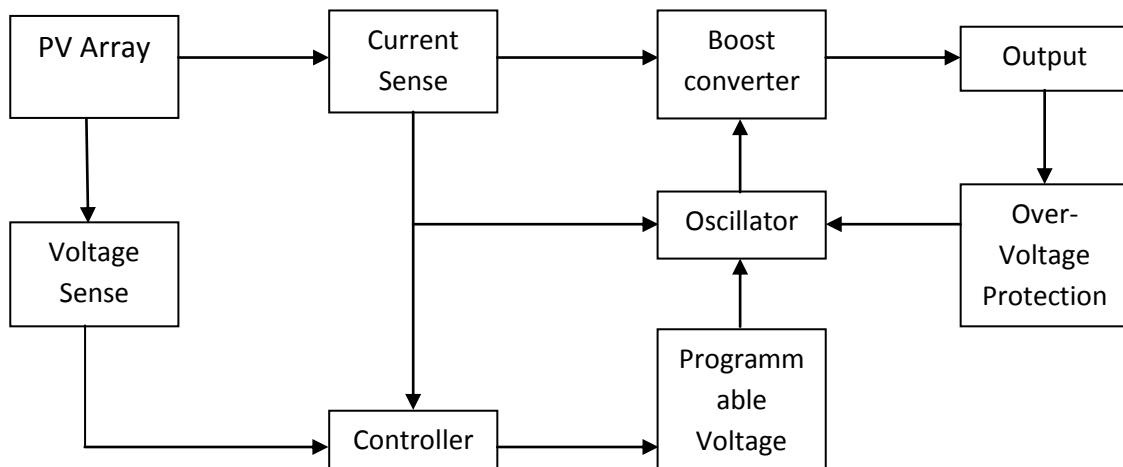

**Figure 20 MPPT Generic Block Diagram – Adopted from a Microchip Application Note**

The PV-array's load, the boost converter, at any given point in time during its functioning is either storing energy or delivering energy to the load. When the inductor is storing energy, the power comes from the solar array. By making the current programmable, the load is made programmable, this is the idea behind the working of a maximum power point tracker.

There are multiple algorithms for microcontroller based tracking systems to track the maximum power point of a sub array.

The MPP of the solar cell/module is not known by default, it is tracked through model calculations or by a search algorithm (25). There are several algorithms mentioned in literature, a few of which have been briefly discussed.

#### **4.4.1 Perturb and Observe**

According to the P&O algorithm, the operating voltage of the PV array is perturbed by a small increment and the resulting change in power is measured, if the change in power is positive the perturbations in operating point of the PV array is continued in the same direction, if the change in power is negative-this means that the PV array's operating point has moved away from its MPP, the algebraic sign of the perturbation is reversed.

The advantages of this algorithm are the ease of implementation and simplicity. The limitations of this algorithm are that in conditions where the incident sunlight decreases, the I-V curve of the solar cell flattens out, making it difficult for the algorithm to determine whether it has moved away or towards the operating point, the second disadvantage is that the algorithm cannot determine when it has reached the MPP, it simply oscillates around this point, changing the sign of the perturbation every time it crosses over.

Many improved versions of the P&O algorithm have been discussed in literature, among which the simplest is adding a delay function to the original algorithm that causes the algorithm to stall if the direction (algebraic sign) of the perturbation has changed multiple times, this has a direct effect in decreasing oscillations at the MPP. In consequence, the algorithm is slow to respond to rapidly changing climatic conditions. Further changes to the algorithm have been suggested which involve increasing the number of samples, which simply slows down the algorithm (25).

#### **4.4.2 Constant Voltage and Current**

The concept behind this algorithm is that the ratio of the  $V_{MPP}$  to the  $V_{OC}$  is approximately constant and is less than 1, this can be derived from observing the I-V curve of a solar cell / panel.

Power point trackers implementing this algorithm typically temporarily isolate the PV array from the power point tracker and make a  $V_{OC}$  measurement. Thereafter, the power point tracker makes an estimation of the MPP based on the ratio ( $V_{MPP}$  to  $V_{OC}$ ), then the tracker adjusts the operating point till MPP is reached. This operation is periodically repeated to track the position of the MPP.

The major disadvantage of using this algorithm is the inherent error in calculating the ratio of  $V_{MPP}$  to  $V_{OC}$ . The other disadvantage is that, the normal operation of the MPPT has to be interrupted to track the MPP.

Constant voltage algorithm although relatively easy to implement using analog hardware, has lower tracing efficiency due to the inherent error in calculating the ratio of  $V_{MPP}$  to  $V_{OC}$  and measuring the open circuit voltage of the PV array requires momentary interruption of power.

A constant current algorithm is also sometimes implemented, this algorithm is similar to the constant voltage algorithm.

The philosophy of this algorithm is to approximate the MPP current as a constant percentage of the short circuit current, this requires the power point tracker to isolate itself from the PV array, a switch is placed across the input terminals of the tracker and is switched on momentarily, the short circuit current is measured and the MPP current is calculated, and the PV array output current is then adjusted by the tracker until the calculated MPP current is reached.

#### **4.4.3 Power Point Trackers-UK Solar car team**

Experience of working with the MPPT has been gained while working with two versions of power point trackers, both were commercial off the shelf (C.O.T.S) products from Drivetek AG, based in Switzerland.

The boards are 200 W-800 W DC-DC boost maximum power point trackers, they have high conversion efficiency, the boards run a closed loop algorithm.

The trackers efficiency depends heavily on the PV array design, the efficiency varies with the voltage conversion factor, as designed conversion factor increases the efficiency of the tracker falls.

The tracker powers itself directly from the PV panel, once the tracker see's an input of 48V on the input (PV array) the microcontroller starts tracking.

## Chapter 5 Drive Systems

### 5.1 Overview

A typical EV drive system encompasses- a motor and a controller, in most cases, the transmission unit is omitted and the motor drive comprising of electric motor, power converter and electronic converter, is the core of the EV drive system in the solar car.

### 5.2 Background

Wheel mounted motors were used for the first time in the WSC 1993 event by three teams, Honda, Engineering college of Biel and Northern Territory University, several other teams followed suit in the following event in 1996 (29).

In a reciprocating engine, the energy to drive the vehicle is produced by igniting a mixture of fuel and air, and the resulting energy from the explosion is used to drive a crankshaft, which drives the transmission unit connected to the crankshaft through a clutch pad, which in-turn drives the wheels.

In a direct-drive coupled Electric Vehicle, a motor directly mounts onto the wheel hub and when supplied with the appropriate amount of power provides the torque to drive the vehicle, a transmission unit is avoided in a solar car to avoid losses that would be accompanied by using such a system.

The major requirements of the drive system are: 1) High instant power and high power density, 2)High torque at low speeds for starting and climbing, 3)high power for high speed cruising, 4) A very wide power band 5) Fast torque response 6) High efficiency over the entire power band , 7) High reliability and 8) Reasonable cost.

The basic considerations for drive systems are: 1) single or multiple drive systems, 2) single or multi speed transmission 3) system voltage, 4) types of motors, motor controllers, and their maximum current and voltage capabilities, 5) motor torque-speed characteristics, maximum torque and maximum speed, 6) types of battery and energy and current capabilities and 7) maximum torque and gear ratio of the transaxle (30).



Traditionally, DC motors have been preferred because their torque-speed characteristics suit traction requirements well and their speed controls are simple, but they also need maintenance owing to the presence of a commutator and brushes. The developments in control electronics, introduction of Integrated Gate Bipolar Transistor (IGBT) have pushed commutator-less motors back into contention as a prime contender for drive systems.

The major contenders for this application specifically are Induction Motors (IM), Permanent Magnet Brushless Motors (PMBM) and in some cases Switched Reluctance Motors (SRM).

IMs are widely accepted because this technology is mature, highly reliable and free from maintenance, PMBMs are promising because they use a permanent magnet to produce a magnetic field, therefore offer higher efficiency and high power density, Switched Reluctance Motors (SRM) are also considered to be prime candidates because of the comparatively simple and robust construction.

On comparing the three drives, it follows that for an extremely power sensitive application like a solar car, a permanent magnet brushless motor is a good fit.

**Table 4- Table comparing three drive systems (33)**

	IM	PMBM	SRM
Efficiency	Low	High	Medium-Low
Power Density	Low	High	Medium
Speed	High	High	Low
Controller Efficiency	Low	High	Medium
Cost	Low	High	Medium
Reliability	High	Low	Medium
Size	Large	Small	Medium - Low

The permanent magnet brushless DC motor that the solar car employs is a hub motor, hub motors typically have the stator fixed on the axle of the drive wheel, in this case the rear wheel of the solar car, with the permanent magnet rotor embedded in the wheel. By directly driving the wheel, the rotor eliminates the requirement of a transmission unit; it also offers advantages like higher efficiencies, occupies less space and is often easy to service. There are two types of hub motors, the radial flux motor where the air gap between the stator and rotor extends radially and the other option is the pancake or disc-type brushless motor, where the air gap between the stator and rotor extends axially, this allows the motor unit to be flat, therefore it can sit flush with the wheel-hub hence not interfering with the air-flow, the solar car team uses a pancake type hub motor. Pulse-Width Modulation (PWM) is used to supply current to the stator coils (33).

Since Gato del sol I, the solar car team has invested in and used only one motor, the NGM SC-M150, this motor offers an efficiency of 95% (at 1 kW), has a peak operating power of 7.5 kW, a peak torque of 135 Nm, weighs 20 kg and operates at a nominal DC voltage of 96V.

To control this motor and send the appropriate power output to the motor based on the driver's controls and other criteria, the motor is interfaced with a motor controller. The solar car team at the time of writing this thesis does not have the capability to build such a system yet. In conjunction with this motor the solar car team has used two motor controllers, the NGM EVC200 and the Tritium Wavesculptor.

The NGM EVC200 series controllers are 96 V controllers that are plug and play controllers when used with the SC-M150 motors used in solar cars. They are ultra-high efficiency sine-wave controllers that provide regenerative braking and are capable of serial communication (RS232).

### **5.3 Issues Resolved**

During the FSGP2009 track event, the team had qualified to race and on the night before the first race day, the car lost drive, after some initial debugging with a multimeter to check whether the motor-controller was receiving appropriate voltages on the input, it

was discovered that the output was not registering any voltage on any of the three phases. After determining the source of the problem, it was discovered that due to a software bug in the motor-controllers firmware, at times the motor-controller would go into fail-safe mode where it would constantly reset itself, this issue was resolved by sending commands to the controller via hyperterminal to refresh the controller's on-board computer and reset the bit that instructs the controller to reset itself when it does not receive a data packet from the drivers interface box for more than 250 ms (this feature is included as a fail-safe mechanism to make sure that the driver is always in control of the throttle and brake pedals).

The Tritium *Wavesculptor* Motor Controller filling in for the NGM EVC402 and essentially performing the same task of applying PWM to the input DC signal and sending out a 3-phase signal, has the additional capability of interfacing with the CAN bus network on the car. Description about this bus is given in the Communication Bus Standards chapter.

## **Chapter 6 Conclusion and Future Work**

### **6.1 Overview**

The control systems implemented on Gato del sol III have been significantly improved to be implemented and tested in Gato del sol IV.

This development has required re-engineering the design and implementation of some hardware components. Furthermore, the software has been upgraded to allow for further expansion of system components and a certain degree of fault tolerance has been integrated.

One of the important components under the focus of development was the Battery Management System, enormous knowledge and experience has been gained in this area over the past one year. Significant amendments in construction practices have been adopted for Gato del sol IV which have all been successful, and was proved by a strong ninth place finish in the ASC2010.

The break-even speed for Gato del sol IV was observed to be 45 mph (ASC2010 set-up,  $\text{Power}_{\text{IN}} = \text{Power}_{\text{OUT}}$ ). This is an increase of 80% in sustainable speed from Gato del sol III.

This section will underline some of the individual achievements and conclusions.

### **6.2 Hardware**

The BPS developed for Gato del sol IV is an improved version of the BPS in Gato del sol III, the re-engineering work was undertaken because the BPS boards had failed about two months prior to the race and the team did not have any documentation with regards to how the BPS is implemented. The BPS on Gato del sol III was originally developed by the NASC-2008 design team, and this design was adopted for Gato del sol IV with modifications. The CAN boards developed for Gato del sol III (NASC-2008 design team) were adopted into the Gato del sol IV system with major changes being made to the software.

A passive Charge balancing system was developed over the past year, it has been bench-tested and functionality test is complete.

The system is yet to be tested in real time, owing to the amendments in battery pack construction; none of the modules were reported going-bad.

The MPPTs purchased from DriveTek for Gato del sol IV have proved to be very reliable, continuing its excellent track record from Gato del sol III.

Surface mount technology has been embraced wherever possible, the BPS boards retain the size and the CBS boards are of a similar size. The size of each CAN board has been reduced by 50%, dual in-line packaging has been replaced by quad packaging (TQFN) for the PIC18F4480 controller and the MCP2551 DIP package has been replaced with surface mount technology (SMT). The terminal header pins for programming have been replaced with standard RJ11 connectors, and to increase reliability and robustness of the system M12 connectors were included on some CAN nodes, libraries for the footprint were developed in CAD software.

CAD EAGLE was used for all the schematic captures and the board layouts. Advanced circuits sponsored the board manufacturing. This involved generating Gerber files from CAD EAGLE and sending them to Advanced Circuits.

Some issues were experienced with the Tritium motor controller during the ASC2010 event, the motor controller has some inherent design faults which would cause the controller to go into a current-error state (the current sensor board during normal car operation could become detached from the mother-board briefly), based on suggestions from Tritium, the PCB that was causing this problem was pushed against the mother-board with some foam and tape.

The drivers expressed inability to push the car to speeds higher than 58 mph on plain roads; the car did attain a top speed of 62 mph while going down an incline, the author attributes this to the pack voltage because speed is directly proportional to voltage in a DC brushless motor. The test to verify this is a simple procedure which would require 10-15 Lead-acid batteries, as long as the pack voltage is within the limits specified by the motor and motorcontroller manufacturer, the configurations can be changed to see change in RPM of the motor under no-load and artificial load conditions.

A board that controls the LCD in the driver's compartment has been included, this board also acts as one of the terminating nodes on the second CAN bus network (CAN bus-2), this board can display quantities like speed, temperature and bus current.

The pack current sensor board uses an ACS750 Hall-effect sensor IC from Allegro Microsystems Inc. The power required is tapped from the 5 V supply rail on a CAN board in close proximity, this CAN board also reads in the voltages from the sensor IC and delivers it onto the CAN bus.

M12 panel mount connectors were used on each of the boxes to increase ease of access to each box. M12 cables sponsored by Balluff Inc. were used.

### **6.3 Software**

The Software has been entirely revamped, the team battled with software reliability during the FSGP2009 event, the software developed for the ASC2010 demonstrated improved reliability and efficiency. The software now also features a certain degree of fault tolerance, the error counters of each CAN protocol generator are tracked and noted and faulty nodes, bad connections or bad cable patches can be tracked easily.

The software provides for expansion of the CAN bus network, care has been taken while assigning CAN IDs, CAN IDs have been defined in canid.def.

Using interrupt service routines has decreased response latency and guaranteed appropriate action.

CAN software filters have been used on all the boards manufactured in-house, this has led to reduced information overload.

### **6.4 Future Work**

Future work will depend heavily on budget constraints and sponsorship level.

## **Hardware**

- The present BPS works very well; it has a very good track record, but limits the battery box design due to inherent characteristics in the design. The present design of the battery-box was found to be inconvenient to perform repairs on. If in case the team decides to use the same BPS design for the FSGP2011 event, the author suggests that the team should think about building a box similar to the Battery Pack III. The next step in BPS design should be a modularized design; such a design can be derived from the present BPS design if required. The team can work in collaboration with other teams that are ready to share information, so that the team is not re-inventing the wheel. In case the team wishes to use the present design, the team can look at swapping the present board power supply from linear regulators to switching-mode power supplies (SMPS), each board at this point consumes 1.2 W (BPS) the car bleeds energy for this, an SMPS will be more efficient and is a minor design change to the present design. Another important amendment is to find a method to isolate the telemetry from the BPS system.
- The team should invest time in building testing rigs for different electrical components which will free different design teams from being dependent on the car to be functioning properly each time the team wishes to test a component.
- The present MPPT has proven to be very reliable, but it is very heavy and very costly, there are teams that make MPPTs in-house, the UK solar car team can collaborate with these teams in designing an in-house MPPT, which will result in some weight savings and more importantly will take pressure away from the team to constantly raise money instead of focusing on research and development.
- The team should gain some experience in making an SMPS, this will prove beneficial when designing a new version of the BPS and in-house MPPTs.

## **Software**

- Learning algorithms can be implemented to improve the efficiency of the Charge Balancing System.
- The present CAN firmware, BPS firmware is reliable and robust, but there are areas for significant improvements, a system where the error counter register for an entire

day drive can be recorded will prove beneficial to the team to pin-point weaknesses and will prove helpful in predicting failure (software or hardware).

Rigorous testing must be undertaken, the better the team knows its car, the better it will perform. The possibility of a routine cycle of driving the car, including the findings from each drive and re-testing must be investigated.

## **6.5 Energy Management**

- The team undertook an aerodynamic efficiency test (tuft test) on Gato del sol III and this proved beneficial in designing and developing Gato del sol IV, the team must undertake a similar test and collect data from it to assess areas of improvement on the car, mechanically whether there is near-seamless integration of all external surfaces on the body, electrically whether the car is bleeding energy excessively in electronics or power circuits.
- The team can also focus on building a simulated version of Gato del sol IV to put it through different conditions and calculate how the power in and power out equation works out which will prove to be an indispensable tool when the team gets to the point of developing a prediction software.



# Appendix

## Appendix-A Car Electrical Layout

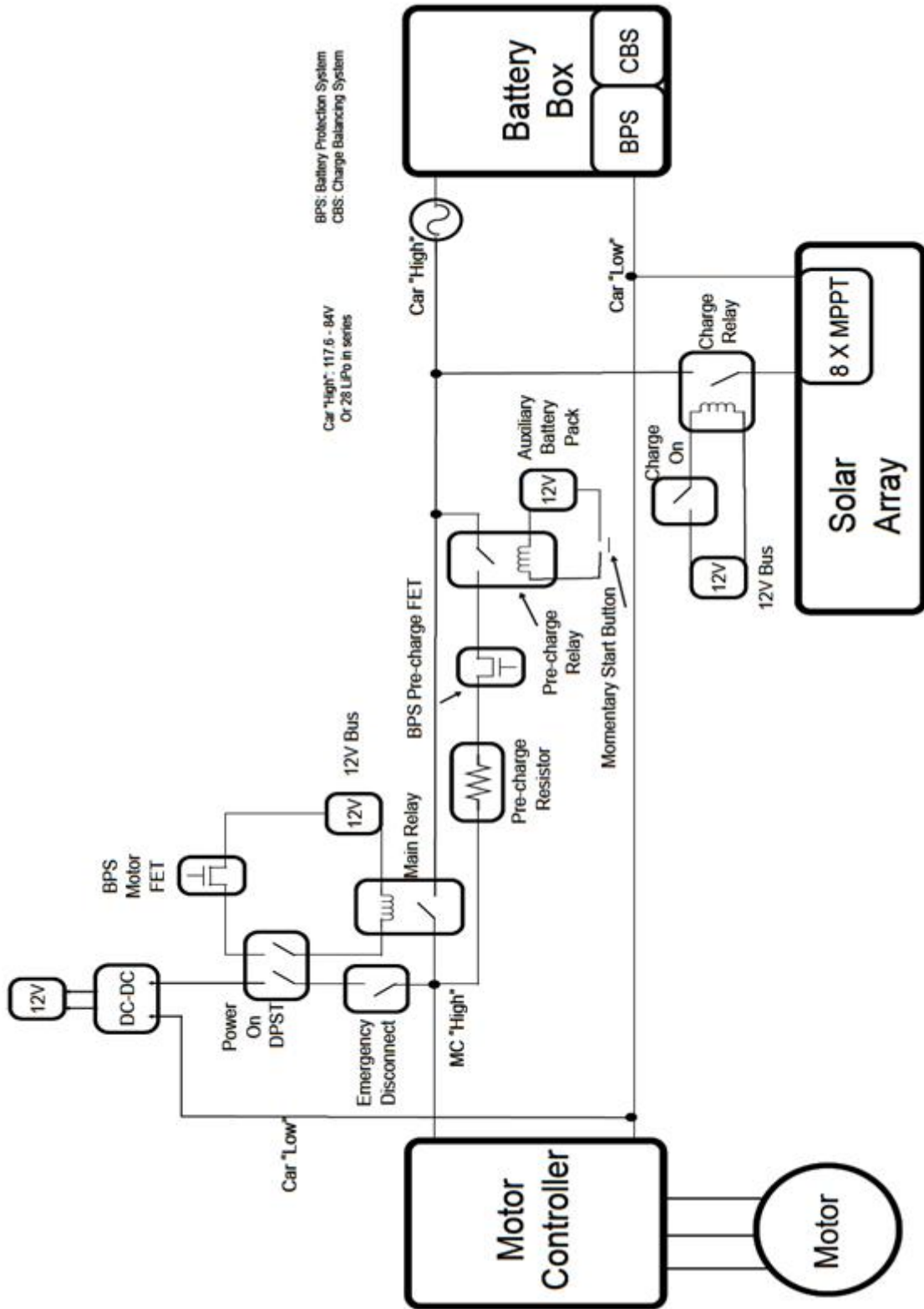

**Appendix-B**  
**CAN Identifiers**

Identifier (in hexadecimal)	Definition
0x100	BPS_MASTER_ERR
0x102	BPS_REQ_1_V
0x104	BPS_REQ_1_T
0x110	BPS_ANS_1_V
0x112	BPS_ANS_1_T
0x200	BPS_ERR_2
0x202	BPS_REQ_2_V
0x204	BPS_REQ_2_T
0x206	BPS_REQ_2
0x210	BPS_ANS_2_V
0x212	BPS_ANS_2_T
0x214	BPS_STAT_2_OK
0x300	BPS_ERR_3
0x302	BPS_REQ_3_V
0x304	BPS_REQ_3_T
0x306	BPS_REQ_3
0x310	BPS_ANS_3_V
0x312	BPS_ANS_3_T
0x314	BPS_STAT_3_OK
0x400	BPS_ERR_4
0x402	BPS_REQ_4_V
0x404	BPS_REQ_4_T
0x406	BPS_REQ_4
0x410	BPS_ANS_4_V
0x412	BPS_ANS_4_T
0x414	BPS_STAT_4_OK
0x500	CURRENT_ERR
0x502	CURRENT_REQ
0x504	CURRENT_ANS
0x600	INITIALIZATION_SUCCESSFUL
0x602	INITIALIZATION_FAILURE
0x710	MPPT_REQ_ONE
0x712	MPPT_REQ_TWO
0x714	MPPT_REQ_THREE
0x716	MPPT_REQ_FOUR
0x718	MPPT_REQ_FIVE
0x71A	MPPT_REQ_SIX
0x71C	MPPT_REQ_SEVEN
0x71E	MPPT_REQ_EIGHT
0x770	MPPT_REQ_ONE
0x772	MPPT_REQ_TWO

0x774	MPPT_REQ_THREE
0x776	MPPT_REQ_FOUR
0x778	MPPT_REQ_FIVE
0x77A	MPPT_REQ_SIX
0x77C	MPPT_REQ_SEVEN
0x77E	MPPT_REQ_EIGHT

## Bibliography

1. *An overview of controller area network*. **M. Farsi, K. Ratcliff and Manuel Barbosa**. 1999, Computing and Control Engineering Journal , pp. 113-120.
2. **Robert Bosch GmbH**.*CAN specification version 2.0*. 1991.
3. *Universal Serial Bus 3.0 Specification*. 2008.
4. *The I2C Bus Specification version 2.1*. 2000.
5. **Gubel, Caio**.*PLL jitter and its effects in the CAN protocol - Microchip Application Note*. 2004.
6. **International Telecommunications Union**.*Open Systems Interconnection - Basic Reference Model*. 1994.
7. **The Ethernet version 1.0**, 1980.
8. **Barak, M.***Electrochemical Power Sources* . London : The Institution of Electrical Engineers, 1980. ISBN 0-906048-26-5.
9. *Cell Balancing Considerations for Lithium-Ion Battery Systems*. **Bentley, W. F.** Dallas,TX : IEEE, 1997. 0-7803-3631-3/97/.
10. **D.Linden**.*Handbook of Batteries and Fuel Cells*. s.l. : McGraw-Hill, 1995.
11. *The Search for Better Batteries*. **Riezenman, M.J.** s.l. : IEEE Spectrum, May 1995, IEEE, pp. 51-56.
12. *Advanced lithium ion battery charger*. **Teofilo, V.L., Merritt, L.V., Hollandsworth, R.P.** Long Beach : IEEE, 1997. 1089-8182 .
13. *Batteries for Low Power Electronics*. **Powers, Robert A.** s.l. : IEEE Spectrum, 1995. Proceedings of the IEEE. Vol. 83, pp. 691-692.
14. **Madapura, Jayanth Murthy**.*Achieving Higher ADC Resolution Using Oversampling*. s.l. : Microchip Application Note, 2008.
15. *EV Battery Pack life: Pack Degradation and Solutions*. **B. Dickinson, D. Swan**. pp. 145-154. SAE paper 951949.
16. *The Development of Lithium-Ion Secondary Battery Systems for EV and HEV*. **Yoshio Nishi, Kiyoshi Katayama, Jyunichi Shigetomi, and Hideaki Horiea**. Long Beach : IEEE, 1998. Battery Conference on Applications and Advances, 1998., The Thirteenth Annual .
17. *A Review of Cell Equalization Methods for Lithium Ion and Lithium Polymer Battery Systems*. **Stephen W. Moore, Peter J. Schneider**. s.l. : Society of Automotive Engineers, 2001.

18. *Battery State-of-Charge Estimation*. **Shuo Pang, Jay Farrell, Jie Du, Matthew Barth**. Arlington : s.n., 2001. Proceedings of the American Control Conference . Vol. 2, pp. 1644-1649.
19. *A Review of Battery Charging Algorithms and Methods*. **Wiegman, Herman L.N.** s.l. : Power Designers, 1999.
20. Linear Technology.*Multicell Battery Stack Monitor - Datasheet* .
21. *American Solar Car Challenge 2012 Regulations*. 2010.
22. *Estimating the State of Charge of a Battery*. **John Chiasson, Baskar Vairamohan**. 2005. IEEE TRANSACTIONS ON CONTROL SYSTEMS TECHNOLOGY,. pp. 465-470.
23. **Carrol, Douglas R.***The Winning Solar Car*. Warrendale : SAE International, 2003. 0-7680-1131-0.
24. **Charais, John.***Maximum Power Solar Converter - Microchip Inc.- Application Note*. 2008.
25. **D. P. Hohm, M. E. Ropp.***PROGRESS IN PHOTOVOLTAICS: RESEARCH AND APPLICATIONS*. s.l. : John Wiley & Sons Ltd., 2002.
26. [http://en.wikipedia.org/wiki/Maximum\\_power\\_point\\_tracker](http://en.wikipedia.org/wiki/Maximum_power_point_tracker). *Wikipedia - The Free Encyclopedia*. [Online] [Cited: 08 20, 2009.]
27. *Dynamic Multiphysics Model for Solar Array*. **Shengyi Liu, Roger A. Dougal**. 2002. IEEE TRANSACTIONS ON ENERGY CONVERSION. Vol. 17. 2.
28. *Optimization of Perturb and Observe Maximum Power Point Tracking Method*. **Nicola Femia, Giovanni Petrone, Giovanni Spagnuolo, Massimo Vitelli**. 2005. IEEE TRANSACTIONS ON POWER ELECTRONICS. Vol. 20. 4.
29. **Green, Martin A.***EVENT REPORT Brain Sport: The 1996 World Solar Car Challenge Solar Car Race Across Australia*. Photovoltaics Special Research Centre, University of New South Wales. s.l. : Progress in Photovoltaics: Research and Applications, 1997.
30. *Advanced Concepts in Electric Vehicle Design*. **Hiroshi Shimizu, Junji Harada, Colby Bland, Kiyomoto Kawakami, Lam Chan**. s.l. : IEEE. IEEE TRANSACTIONS ON INDUSTRIAL ELECTRONICS,. Vol. 44, pp. 14-18. 1.
31. David Snowdon “*Hardware and Software Infrastructure for the Optimization of Sunswift II*”, Bachelor’s Thesis, University of New South Wales, November 2002.
32. *An Investigation of Electric Motor Drive Characteristics for EV and HEV Propulsion Systems*. **Z. Rahman, M. Ehsani, K. L. Butler**. Costa Mesa : SAE International, 2000. Future Transportation Technology Conference.

33. **Chang, L.** *Comparison of AC Drives for Electric Vehicles-A Report on Experts Opinion Survey*. Fredericton : IEEE AES Systems Magazine , 1994.

### **Vita**

Krishna Prayaga was born in Hyderabad, India, on November 22<sup>nd</sup> 1985. He graduated from ICFAI Institute of Technology, ICFAI University in August 2007 with Bachelors in Electrical Engineering.

He worked at TATA communications for six months as a Network Engineer. He later worked as a teaching assistant at ICFAI Institute of Technology. He then joined the Master's program in Electrical Engineering at the University of Kentucky in the spring of 2008. During his Master's he worked with the University of Kentucky Solar Car Team as the Lead Electrical and Systems Engineer. He co-authored a paper on alternative energies and was invited to present in the IEEE Green Technologies Conference in 2009 at Dallas, TX.