



University of Groningen

Observation of the one-exciton to two-exciton transition in a J aggregate

Fidder, Henk; Knoester, Jasper; Wiersma, Douwe A.

Published in:
The Journal of Chemical Physics

DOI:
[10.1063/1.464797](https://doi.org/10.1063/1.464797)

IMPORTANT NOTE: You are advised to consult the publisher's version (publisher's PDF) if you wish to cite from it. Please check the document version below.

Document Version
Publisher's PDF, also known as Version of record

Publication date:
1993

[Link to publication in University of Groningen/UMCG research database](#)

Citation for published version (APA):

Fidder, H., Knoester, J., & Wiersma, D. A. (1993). Observation of the one-exciton to two-exciton transition in a J aggregate. *The Journal of Chemical Physics*, 98(8), 6564-6566. <https://doi.org/10.1063/1.464797>

Copyright

Other than for strictly personal use, it is not permitted to download or to forward/distribute the text or part of it without the consent of the author(s) and/or copyright holder(s), unless the work is under an open content license (like Creative Commons).

Take-down policy

If you believe that this document breaches copyright please contact us providing details, and we will remove access to the work immediately and investigate your claim.

Downloaded from the University of Groningen/UMCG research database (Pure): <http://www.rug.nl/research/portal>. For technical reasons the number of authors shown on this cover page is limited to 10 maximum.

Observation of the one-exciton to two-exciton transition in a J aggregate

Henk Fidler, Jasper Knoester, and Douwe A. Wiersma
*Ultrafast Laser and Spectroscopy Laboratory, Materials Science Centre, University of Groningen,
Nijenborgh 4, 9747 AG Groningen, The Netherlands*

(Received 28 December 1992; accepted 8 February 1993)

We report on the first observation of the one-exciton to two-exciton transition in J aggregates. A theoretical analysis supports our interpretation.

We report on the first observation of a one-exciton to two-exciton transition in a molecular assembly: the J aggregate. One-exciton (or Frenkel) states have been studied extensively in this aggregate as well as in other molecular systems. Two-exciton states, however, have received considerably less attention. This is surprising because these states play an important role in molecular solids as doorway states in the exciton-exciton annihilation process,¹ and, as was recently shown, in determining the size dependence of optical nonlinearities.² Exploration of the one-exciton to two-exciton transition and the two-exciton dynamics, therefore, seems extremely relevant for extending our fundamental understanding of molecular solids and for advancing the field of molecular electronics. In this Communication we show that two-color picosecond pump-probe experiments provide a convenient means to study these states.

The experiments were performed on the J aggregate of pseudo-isocyanine-bromide (PIC-Br) in a glass of 1:1 ethylene glycol/water at 1.5 K. The aggregates were made by cooling a 5×10^{-3} M solution slowly to 77 K. The ps pump-probe experiments were done by using two R6G dye lasers, synchronously pumped by the same mode-locked argon ion laser. Typical pulse widths of the pump and probe pulses were about 4 ps; the jitter between the two lasers was 40 ± 10 ps.

Figure 1 displays the main result of our experiments. It shows the differential absorption spectrum (difference of the probe absorption spectra with and without pumping) for zero delay and a pump wavelength of 576.0 nm, which is near the peak of the "red" J band (see insert). We first note that the strength of this signal strongly depends on the pump wavelength and correlates very well with the aggregate absorption. Furthermore, at the pump wavelength the intensity of the signal drops with a time constant shorter than 20 ps, in agreement with the known exciton dynamics of the J band.³ Both these facts prove that the spectrum in Fig. 1 is due to exciton transitions in the J aggregate. Two features stand out in Fig. 1: a strong bleach at the excitation wavelength and an equally intense, but slightly blue-shifted, increased absorption. In the remainder of this Communication we will show that this increased-absorption signal can be assigned to a *one-exciton to two-exciton transition*. In fact, we demonstrate that the differential absorption signal displayed in Fig. 1 can be completely reproduced using the same microscopic parameters that have been obtained from an earlier analysis of the one-exciton transition in J aggregates⁴ of PIC-Br.

In order to analyze the pump-probe experiment on the

J band, we will treat the aggregates as chains of interacting two-level molecules described by the Frenkel exciton Hamiltonian with Gaussian diagonal disorder (mean molecular transition frequency Ω , standard deviation D). The molecular transition dipoles μ are taken parallel to each other. This model is well accepted; previously, we have shown that it explains the low temperature linear optical properties of J aggregates.⁴ The eigenstates of this model occur in bands characterized by the number of excitations that are shared by the molecules on the chain (ground state, one-excitons, two-excitons,...), as displayed in Fig. 2.⁵⁻⁷ Multiexciton states can only be probed by nonlinear optical experiments. The pump-probe experiment is, to lowest order in the laser intensities, a third-order optical technique.⁸ However, we will use a more intuitive picture and treat it as a sequence of two linear absorption experiments, of which the second occurs from the state prepared by the pump pulse (sequential pump-probe). In this view, the pump pulse creates one-excitons, which during the pump-probe delay may relax to the ground state and (or)

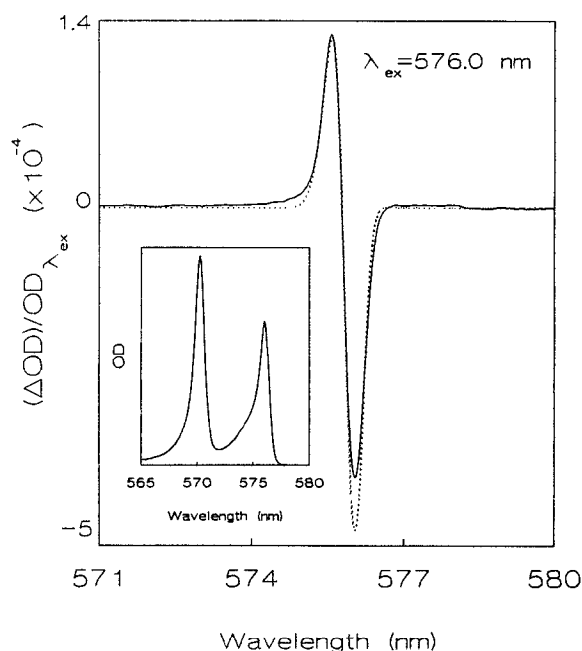

FIG. 1. Differential absorption spectrum (—) of PIC-Br aggregates at 1.5 K, when pumping at 576.0 nm. The dotted line is the spectrum calculated from Eq. (1), using the parameters discussed in the text. The insert displays the (linear) absorption spectrum at 1.5 K.

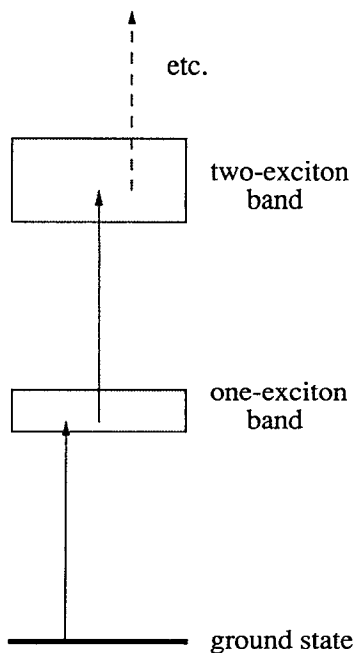

FIG. 2. Schematic representation of the lower part of the level scheme for Frenkel-exciton systems. The arrows indicate allowed transitions.

redistribute over the one-exciton band by scattering on phonons. Information on the state of the system after the delay is obtained from the absorption of the probe beam. Strictly speaking, the sequential pump-probe picture is only valid if the delay is long compared to the pulse durations.

A simple expression for the pump-probe signal from disordered chains is obtained through perturbation theory in D/V , where V is the nearest-neighbor intermolecular interaction. In particular, we will use the (multi)exciton energies to first order in D/V and the unperturbed (homogeneous) wave functions. The dominant relevant transitions then occur between the ground state and the $k=1$ one-exciton, and between the $k=1$ one-exciton and the $(k_1, k_2) = (1, 2)$ two-exciton. The corresponding oscillator strengths and transition frequencies are $\mu_{01}^2 \approx 0.81N\mu^2$, $\mu_{1,12}^2 \approx 1.27N\mu^2$ and Ω_1 , Ω_2 , respectively.^{5,6} Here, N denotes the number of (coherently coupled) molecules on the chain and Ω_k denotes the frequency of the k th one-exciton to first order in the disorder. Taking only these transitions into account and neglecting any dynamics during the delay, we find for the differential absorption:

$$\Delta\sigma(\omega_1, \omega_2) \propto P(\omega_1) \left\{ -2 \frac{1}{\sqrt{2\pi} W} \exp \left[-\frac{(\omega_1 - \omega_2)^2}{2W^2} \right] + \frac{\mu_{1,12}^2}{\mu_{01}^2} P(\omega_2 | \omega_1) \right\}. \quad (1)$$

Here, ω_1 and ω_2 denote the central frequencies of the pump and the probe pulses, respectively, and W is the standard deviation (FWHM/2.35) of the convolution of the Gaussian power spectra of the two pulses. Furthermore, $P(\Omega_1)$ is the probability distribution for Ω_1 , which is a Gaussian

centered around the homogeneous frequency $\Omega_1^0 = \Omega + 2V \cos [\pi/(N+1)]$ with a standard deviation $D_J = D[3/2(N+1)]^{1/2}$. $P(\omega)$ gives the well-known motionally narrowed linear absorption spectrum.⁹ Finally, $P(\Omega_2 | \Omega_1)$ is the conditional probability distribution for Ω_2 , given the value of Ω_1 . It can be shown¹⁰ that for $N \gg 1$, $P(\Omega_2 | \Omega_1)$ is Gaussian in Ω_2 with a standard deviation $D_C \approx D(5/6N)^{1/2}$ and center $\Omega_2^0 + \gamma(\Omega_1 - \Omega_1^0)$, where $\Omega_2^0 = \Omega + 2V \cos [2\pi/(N+1)]$ (the homogeneous $k=2$ one-exciton frequency) and $\gamma=2/3$. Equation (1) has been derived assuming that the J band is broad compared to the spectral width of the pump and probe pulses, which, in turn, are broad compared to the homogeneous widths of the excitonic transitions. The first (negative) term in Eq. (1) describes bleaching and stimulated emission (equally large) of one-exciton transitions, whereas the second (positive) term describes extra absorption due to the transition from the one- to the two-exciton band. For J aggregates ($V < 0$) pumped close to resonance, this absorption occurs to the blue side of the bleaching. In order to use Eq. (1) in practice, where the disorder and the chain length are too large to justify the perturbative approach, we replace N by the exciton delocalization length $N_{\text{del}} < N$. This procedure is heuristic, but works surprisingly well in, for instance, explaining the $D^{4/3}$ dependence of the width of the J band on the disorder.⁴ In Fig. 1, Eq. (1) is compared to the observed differential absorption spectrum. The input parameters have been taken from our previous analysis of the linear optics of the J aggregate: $N_{\text{del}} = 50$, $D = 64 \text{ cm}^{-1}$, and $V = -720 \text{ cm}^{-1}$;^{4,11} furthermore, $W = 5.5 \text{ cm}^{-1}$. The ex-

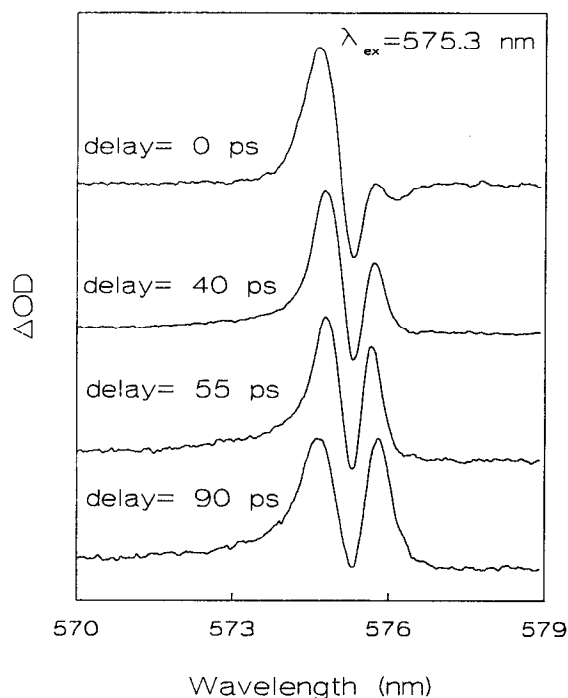

FIG. 3. Differential absorption spectra for various pump-probe delays at 1.5 K, after pumping at 575.3 nm. Note that the intensity scale is arbitrary. In reality, the increased absorption signal intensity has decreased by a factor 4 from 0 to 90 ps pump-probe delay.

cellent agreement between the experimental and calculated trace strongly supports our contention that the increased-absorption signal is due to transitions between the *one-exciton* and *two-exciton band* in the *J* aggregate. We further conclude that the homogeneous width of this excitonic transition cannot exceed 5 cm^{-1} , putting a lower limit of 1 ps on the two-exciton lifetime.

Figure 3 shows a series of scans performed for several pump-probe delays after pumping at 575.3 nm (on the high energy side of the *J* band). In the zero delay scan a new bleach peak is observed at about 576.1 nm. This peak may be caused by bleaching of the $k=1$ one-exciton, related to pumping of some $k=3$ one-exciton states in the high energy tail of the *J* band. When the pump-probe delay is increased the signal intensity decreases rapidly and the bleach feature becomes overwhelmed by the rise of another increased-absorption signal. It is tempting to attribute this effect to intraband relaxation. However, concomitant with this increased absorption signal a bleach signal is expected at the low energy edge of the *J* band. A possible reason for the absence of this additional bleach signal is the use of a spectrally broad probe pulse ($\text{FWHM}=12\text{ cm}^{-1}$). It is also conceivable that full numerical calculations will show that the extra bleach, ex-

pected on the basis of the above perturbative treatment, cannot be observed.

Additional nonlinear optical experiments and numerical calculations are planned to further explore one-exciton to two-exciton transitions in molecular assemblies.

This research was supported by the Netherlands Foundation for Scientific Research (NWO).

- ¹V. Sundström, T. Gillbro, R. A. Gadonas, and A. Piskarskas, *J. Chem. Phys.* **89**, 2754 (1988).
- ²F. C. Spano and S. Mukamel, *Phys. Rev. A* **40**, 5783 (1989).
- ³H. Fidler, J. Terpstra, and D. A. Wiersma *J. Chem. Phys.* **94**, 6895 (1991).
- ⁴H. Fidler, J. Knoester, and D. A. Wiersma, *J. Chem. Phys.* **95**, 7880 (1991).
- ⁵F. C. Spano, *Phys. Rev. Lett.* **67**, 3424 (1991).
- ⁶J. Knoester, *Phys. Rev. A* **47**, 2083 (1993).
- ⁷Two-exciton states should not be confused with biexcitons, which are pairs of excitations bound by an attractive potential.
- ⁸Y. J. Yan, L. E. Fried, and S. Mukamel, *J. Phys. Chem.* **93**, 8149 (1989).
- ⁹E. W. Knapp, *Chem. Phys.* **85**, 73 (1984).
- ¹⁰J. Knoester (in preparation).
- ¹¹We use an effective nearest-neighbor coupling of -720 cm^{-1} instead of -600 cm^{-1} , to compensate for the contributions of longer range dipolar interactions to the total width of the one-exciton band.