

Fall 1991

Analytical methodology for ATM control panel design

Donald C. Johnson

New Jersey Institute of Technology

Follow this and additional works at: <https://digitalcommons.njit.edu/theses>



Part of the [Industrial Engineering Commons](#)

Recommended Citation

Johnson, Donald C., "Analytical methodology for ATM control panel design" (1991). *Theses*. 1285.
<https://digitalcommons.njit.edu/theses/1285>

This Thesis is brought to you for free and open access by the Theses and Dissertations at Digital Commons @ NJIT. It has been accepted for inclusion in Theses by an authorized administrator of Digital Commons @ NJIT. For more information, please contact digitalcommons@njit.edu.

Copyright Warning & Restrictions

The copyright law of the United States (Title 17, United States Code) governs the making of photocopies or other reproductions of copyrighted material.

Under certain conditions specified in the law, libraries and archives are authorized to furnish a photocopy or other reproduction. One of these specified conditions is that the photocopy or reproduction is not to be “used for any purpose other than private study, scholarship, or research.” If a user makes a request for, or later uses, a photocopy or reproduction for purposes in excess of “fair use” that user may be liable for copyright infringement,

This institution reserves the right to refuse to accept a copying order if, in its judgment, fulfillment of the order would involve violation of copyright law.

Please Note: The author retains the copyright while the New Jersey Institute of Technology reserves the right to distribute this thesis or dissertation

Printing note: If you do not wish to print this page, then select “Pages from: first page # to: last page #” on the print dialog screen

The Van Houten library has removed some of the personal information and all signatures from the approval page and biographical sketches of theses and dissertations in order to protect the identity of NJIT graduates and faculty.

ABSTRACT

Analytical Methodology for ATM Control Panel Design

by

Donald C. Johnson

This thesis presents a methodology for control panel design and layout along with a case study of an automated teller machine (ATM). A predictive model of human endurance and fatigue is developed from anthropometric, biomechanical and kinematics research. The layout problem is formulated to assign controls to locations to minimize the fatigue imposed on an operator performing a known set of tasks. A family of optimal and near-optimal layouts are found using conventional algorithms. The final hardware design refinements are suggested by human factors concerns. Ergonomic guidelines are also proposed for software aspects of the design. The methods and guidelines can provide hardware and software designers with useful insights into some human-machine interface considerations.

**ANALYTICAL METHODOLOGY FOR ATM
CONTROL PANEL DESIGN**

by

Donald C. Johnson

A Thesis
Submitted to the Faculty of the Graduate Division of the
New Jersey Institute of Technology
in Partial Fulfillment of the Requirements for the Degree of
Master of Science in Industrial Engineering
Department of Mechanical and Industrial Engineering
Division of Industrial and Management Engineering
December 1991

Copyright © 1991 by Donald C. Johnson

ALL RIGHTS RESERVED

APPROVAL PAGE

**Analytical Methodology
for ATM Control Panel Design**

by

Donald C. Johnson

Dr. Suebsak Nanthavanij, Thesis Advisor
Assistant Professor, Division of Industrial and Management Engineering,
Department of Mechanical and Industrial Engineering.

Dr. Layek Abdel-Malek, Committee Member
Associate Chairperson and Professor, Division of Industrial and Management
Engineering, Department of Mechanical and Industrial Engineering.

Dr. Howard Gage, Committee Member
Associate Professor, Division of Industrial and Management Engineering,
Department of Mechanical and Industrial Engineering.

BIOGRAPHICAL SKETCH

Author: Donald C. Johnson

Degree: Master of Science in Industrial Engineering

Date: December, 1991

Undergraduate and Graduate Education:

Master of Science in Industrial Engineering, New Jersey
Institute of Technology, Newark, NJ, 1991.

Bachelor of Science in Industrial Engineering, New
Jersey Institute of Technology, Newark, NJ, 1988.

Major: Industrial Engineering

Professional Positions held:

Chief Engineer, United States Electronics Corp,
Springfield, NJ, 1988-91.

Engineering Supervisor, Cosmo Plastics Company, Long
Branch, NJ, 1977-84.

ACKNOWLEDGEMENT

The author wishes to express his sincere gratitude to Professor Suebsak Nanthavanij for his expert assistance, valued guidance, and patient support as advisor.

Special thanks to Professors Layek Abdel-Malek and Howard Gage for serving as members of the committee, and to Professor Ian Fisher for his technical assistance.

The author also wishes to acknowledge the other members of the faculty and staff of the Department of Industrial and Management Engineering and the Graduate Division at New Jersey Institute of Technology for their support and assistance during graduate studies.

The author is grateful to the State of New Jersey for the Garden State Graduate Fellowship award, the proceeds of which served to enable the author to continue his education and attain his degree goals.

TABLE OF CONTENTS

LIST OF TABLES.....	ix
LIST OF FIGURES.....	xi
1 INTRODUCTION.....	1
1.1 The General Layout Problem.....	1
1.2 Automated Teller Machine Case Study.....	2
1.3 Sequence of the Discussion.....	9
2 LITERATURE REVIEW.....	12
2.1 Ergonomic Design of Workplaces.....	12
2.2 Subjective Layout Techniques.....	12
2.3 Heuristic Techniques.....	13
2.3.1 Logical Evaluation Techniques.....	14
2.3.2 Link Analysis Model.....	16
2.4 Quantitative Techniques.....	19
2.4.1 Categories of the Layout Problem.....	19
2.4.2 Quadratic Assignment Problem.....	22
2.4.3 Special Cases of the Location Problem.....	24
2.4.4 Linear Programming Problem.....	25
2.4.5 Stochastic Modeling.....	26
2.4.6 Markov Activity Models.....	26
2.5 Human Factors Research.....	28
2.5.1 Physical Workplace Dimensions.....	28
2.5.2 Controls and Displays.....	30
2.5.2.1 Keyboards and Keypads.....	32
2.5.2.2 Video Display Terminals.....	36
2.5.2.3 Character Displays.....	37
2.5.2.4 Video Display Viewing Angle.....	38
2.6 Ergonomics and Biomechanics Research.....	40
2.7 Analysis of Manipulator Systems.....	43
2.8 Software Ergonomics.....	43
2.8.1 Response Time.....	44
2.8.2 Computer Dialogues.....	45
2.9 Human Anthropometry and Capabilities.....	47
2.10 Automated Teller Machine Studies.....	48
3 PRELIMINARIES.....	50
3.1 Overview of Workstation Design.....	50

3.2	Hardware Control Specifications.....	52
3.2.1	Control Accessibility.....	52
3.2.2	Ease of Use.....	53
3.2.3	Freedom from Errors.....	53
3.3	Human Factors in Button Selection.....	54
3.3.1	Control Physical Parameters.....	54
3.3.2	Coding and Labeling.....	56
3.3.3	Feedback Characteristics.....	57
3.3.4	Standardization.....	57
3.3.5	Stereotypes.....	58
3.4	Control Proximities.....	58
3.5	Input Error Rates.....	58
3.6	Stochastic Model.....	60
3.6.1	Classification of States.....	60
3.6.2	Steady-state Probabilities.....	63
3.6.3	Semi-Markov Process.....	67
3.6.4	Goal Programming.....	67
3.7	Ergonomic Design Factors.....	69
3.7.1	Design Population.....	69
3.7.2	User Base Skill Level.....	71
3.7.3	Defining the Control Panel.....	78
3.7.4	Accessibility of Controls.....	79
3.8	Finding the Optimal Layout.....	80
3.8.1	Complexity of the Layout Problem.....	81
3.8.2	Types of Assignment Costs.....	82
3.8.2.1	Motion Costs.....	82
3.8.2.2	Position Costs.....	86
3.8.3	Biomechanical Analysis.....	88
3.8.3.1	Human Work Endurance.....	88
3.8.3.2	Biomechanical Joint Analysis.....	90
3.8.4	Arm Kinematic Analysis.....	91
3.8.4.1	Forward Kinematics.....	91
3.8.4.2	Inverse Kinematics.....	92
3.9	Determining Optimal Control Location.....	93
3.10	Determining Endurance Time Penalty.....	93
3.11	Optimization Methods.....	95
3.11.1	Linear Programming Solution.....	96
3.11.2	Linear Assignment Model.....	97
3.11.3	Linear Assignment Solution.....	98
4	METHODOLOGY.....	104
4.1	Operational Analysis.....	105
4.2	ATM Transaction Models.....	112
4.2.1	Case I - Ideal Case.....	112

4.2.2 Case II - Human Error Model.....	114
4.2.3 Case III - Multitranaction Model.....	116
4.2.4 Transaction Conditional Probabilities.....	118
4.3 ATM Stochastic Models.....	120
4.3.1 Transition Probabilities.....	120
4.3.2 Composite Transition Diagrams.....	126
4.3.3. Composite Transition Matrices.....	129
4.3.4 Steady-State Solution.....	132
4.4 Arm Kinematics.....	134
4.4.1 Simple Manipulators.....	135
4.4.2 Multiple Link Manipulators.....	138
4.4.3 Inverse Kinematics (Joint Solution).....	141
4.4.4 Denavit-Hartenberg Algorithm.....	143
4.5 Formulation of Linear Assignment Model.....	145
4.6 Numerical Arm Solution.....	146
5 CASE STUDY - ATM CONTROL PANEL DESIGN.....	148
5.1 Problem Definition.....	148
5.3 Predictive Model of Endurance Time.....	157
5.3.1 Effect of Force on Endurance.....	157
5.3.2 Effect of Elbow Angle on MVC Force.....	160
5.3.3 Estimating Endurance Time.....	160
5.4 Linear Assignment Model Formulation.....	164
5.5 Solution of Assignment Model.....	170
5.6 Layout Recommendations.....	170
5.7 Software Ergonomics.....	174
5.7.1 Video Screen Layout.....	174
5.7.2 Design Simplification.....	174
5.7.3 Social Amenities.....	175
5.7.4 Implicit Input Requests.....	175
5.7.5 Entry Error Handling and Logging.....	176
5.7.6 Global and Local Patterns.....	177
5.7.7 System Default Strategies.....	177
5.7.8 Response-Based Defaults.....	178
5.7.9 Evolutionary Interface.....	178
5.7.10 Multilevel ATM Interface Design.....	179
6 CONCLUSIONS AND RECOMMENDATIONS.....	185
BIBLIOGRAPHY.....	188
APPENDIX.....	196

LIST OF TABLES

Table	Page
3.1 Recommended Physical Parameters for Push-Buttons for Various Modes of Operation	55
3.2 Recommended Physical Parameters for Push-Buttons for Selected Applications	55
3.3 Expected Keystrokes and Predicted Task Error Rates for ATM Keying Activities	61
3.4 Sample One-Step Markov Transition Matrix	65
3.5 Markov Transition Matrix after 256th Multiplication	65
3.6 ATM Usage by Selected Demographic Factors.....	72
3.7 Selected U.S. Population Statistics.....	74
3.8 Bayesian Analysis of ATM User Population	75
3.9 Motion Costs for Equally-Spaced Controls on a Control Panel of N Feasible Locations.....	84
3.10 Distance Cost Matrix for 3.0-inch Equally-Spaced Controls on a 12-Control Panel	85
4.1 Input/Output Objects List for Typical ATM	106
4.2 Activity Elements List for Typical ATM.....	106
4.3 Task Elements and Loci for ATM Transaction Types	110
4.4 Distribution of ATM Activities by Transaction Type	111
4.5 Conditional Probabilities and Distribution of Two Transactions.....	119
4.6 One-Step Transition Matrix for ATM Withdrawals	124
4.7 One-Step Transition Matrix for ATM Deposits.....	124
4.8 One-Step Transition Matrices for ATM Transfers.....	125
4.9 One-Step Transition Matrix for ATM Inquiries.....	125
4.10 Composite Transition Matrix - Case I.....	130
4.11 Composite Transition Matrix - Case II	130

4.12 Composite Transition Matrix - Case III.....	131
4.13 Steady-State Solutions for ATM Models.....	133
5.1 Computer Solution of Joint Angles.....	155
5.2 Probability Distribution of Multiple Visits and Expected Visits to Each Node	167
5.3 Location Parameters and Assignment Cost Matrix for Case III.....	168

LIST OF FIGURES

Figure	Page
1.1 Layout for IBM Automated Teller Machines.....	6
1.2 Layout for NCR Automated Teller Machines.....	7
2.1 Relationship Chart for Link Analysis	18
2.2 Operational Guide to Layout Problems, Part 1	20
2.3 Operational Guide to Layout Problems, Part 2.....	21
2.4 Activity Sequence Generator.....	27
2.5 Workspace Arrangement Guide for Seated Operations.....	29
2.6 Preferred Dimensions for Standing Workplaces.....	31
2.7 Numeric Keypad Layouts.....	33
2.8 Display Legends for Function Keys.....	35
2.9 Preferred Viewing Angles.....	39
2.10 Muscular Strength and Endurance Time	42
3.1 Selected Anthropometric Data for Design Population	70
3.2 ATM User Population by Age and Sex.....	76
3.3 ATM User Population by Education and Income.....	77
3.4 Three Control Arrangements with Identical Motion Costs	87
3.5 Force Available at Various Elbow Configurations.....	89
3.6 Computer Solution of Assignment Problem by ASGN.....	103
4.1 Typical ATM Session Flowchart.....	108
4.2 Forced Exit ATM Session Flowchart.....	109
4.3 ATM Activity Sequences (Case I)	113
4.4 ATM Activity Sequences (Case II).....	115

4.5 ATM Activity Sequences (Case III)	117
4.6 ATM Transition Diagram (Case I).....	122
4.7 ATM Transition Diagram (Case II)	127
4.8 ATM Transition Diagram (Case III).....	128
4.9 Coordinate Frames for Simple Manipulator	136
4.10 Link Coordinate Systems for Six-Joint PUMA Arm.....	140
4.11 Transformation Matrices for Six-Joint PUMA Arm.....	140
4.12 Two-Link Articulated Arm.....	142
5.1 Heights of 5th Percentile Female Stewardesses.....	149
5.2 Link Lengths for 5th Percentile Females.....	149
5.3 Reference Planes for Standing Operator.....	151
5.4 Control Panel Dimensions	153
5.5 Range of Motion for Upper Body.....	154
5.6 Endurance Time and Percentage of MVC	159
5.7 Endurance Time and Percentage of MVC	159
5.8 Graph of Isometric Force vs. Elbow Angle.....	161
5.9 Available Force (A) at Selected Joint Angles (f).....	163
5.10 Relative Force (R) at Selected Joint Angles (f).....	163
5.11 Predicted Endurance Times and Fatigue Rates	165
5.12 Forced Exit ATM Session Flowchart.....	166
5.13 Layout for ATM Control Panel #1	171
5.14 Layout for ATM Control Panel #2.....	171
5.15 Layout for ATM Control Panel #3.....	172
5.16 Layout for ATM Control Panel #4.....	172

5.17 Preferred Layout for ATM Control Panel	173
5.18 Default ATM Top Level Menu Provided to All Users	180
5.19 Individualized ATM Top Level Menu	180
5.20 Flowchart for an Adaptive User Proficiency System.....	184

CHAPTER 1 INTRODUCTION

1.1 The General Layout Problem

In general, several approaches have been used in designing and planning the layouts of various types of facilities. Several qualitative and quantitative techniques traditionally employed in general layout problems are considered. In general, subjective techniques based on heuristics yield suboptimal results, while optimization methods such as quadratic assignment or goal programming give exact solutions, but are too computationally complex for use on practical problems.

It is conjectured that many control panel layout problems are of a class that allows optimization by special methods. When transportation costs are insignificant, less complex linear optimization algorithms can find an optimal arrangement of controls. The proposed objective function assigns controls to locations within a user's reach envelope, with the goal of minimizing the level of fatigue experienced by the human operator.

A methodology is presented whereby a set of costs is developed as a function of the human body's positions in performing a given set of tasks. The costs are determined from the well known relationship between endurance time and the fraction of a muscle's maximum voluntary contraction (MVC) imposed by the task (Caldwell, 1964). As MVC varies with body configuration, the endurance time can be predicted for any point in the range of motion.

From anthropometric data and kinematic analysis, the specific configuration - hence endurance time - is predicted for each feasible control location.

A series of optimal layouts are found and the final hardware design refinements are suggested by human factors and other considerations. Other ergonomic guidelines are proposed for the software aspect of the design. The developed guidelines can help provide hardware and software designers with useful insights into some practical human-machine interface design considerations.

1.2 Automated Teller Machine Case Study

An automated teller machine (ATM) is a computerized device comprised of mechanical and electronic components which permits users to conduct simple banking and other financial transactions. Without the need for the assistance of a human teller, the users, who are members of the general public, can make deposits, withdrawals, transfers, and account queries at any time during or outside of the regular business hours of the financial institution.

Originally, the ATM machine was introduced to solve the problem of ever-increasing costs to financial institutions for processing some routine transactions and delivering services to consumers. Over the past decade, the trend in the banking industry has been to install ATMs in increasing numbers in order to reduce the necessity of using human tellers for those transactions. Successful implementation of this strategy will relieve customer-contact personnel of menial

paper shuffling tasks and allow tellers and other platform personnel to provide other services or perform complicated transactions.

In recent years, ATMs have come into very wide use, with 75,000 units installed in the United States, representing a capital investment of more than \$4 billion, and annual operating and maintenance expenses of over \$300 million. However, the utilization rate of currently installed ATMs (14%) has fallen far short of the system's potential productivity of one transaction per minute (Haynes, 1990).

Although the locations of ATMs are typically at the banks, either indoors (in a bank lobby) or outdoors (through-the-wall), they are also frequently found in shopping malls or supermarkets in a stand-alone island. Furthermore, "drive-thru" ATMs which can be operated from the driver's seat of an automobile are available in some areas.

Currently, there are several types of ATMs in use due to different manufacturers. Among the approximately eight ATM manufacturers, the largest three, namely Diebold, International Business Machines (IBM), and National Cash Register Company (NCR), account for the majority of the installed base. Depending on the manufacturer and type, the cost of a single remote ATM unit usually ranges between \$30,000 and \$67,000 (plus installation and repair or maintenance contracts). The costs of computer and network communication services and in-house or third party loading and unloading services are additional.

There are several computerized banking systems in existence today. The two largest networks, Cirrus Systems, Inc., a division of MasterCard and Plus Systems Inc. together serve a total of 425 million card holders (Seidenberg, 1990). The hardware and software configurations of the actual ATM terminals belonging to the competing communications networks appear functionally to be nearly identical. Of the 75,000 machines, 92.8% are on-line - connected to the network of mainframes - and have access to customer banking records (van der Velde, 1982).

While the designs and features of ATMs can vary depending on the manufacturer, certain basic component parts are commonly found on all ATMs. They are as follows:

- * Input devices

- Magnetic card readers
- Push buttons
- Keypads and Keyboards
- Touch sensitive screens

- * Output devices

- Cathode Ray Tubes (CRTs)
- Electroluminescent Displays (ELDs)
- Light Emitting Diode (LED) displays

- * Dispensing and intake devices

- Cash dispensing mechanism
- Receipt printing and dispensing mechanism
- Deposit acceptance chute or mechanism

* Convenience features

- Storage area for deposit envelopes
- Pen for filling out deposits
- Writing area

It is likely that an ATM user will encounter several types of machines in the normal course of travels within a relatively small radius. There are two main reasons for this. First, the distribution of ATM types appears to be uniform, rather than geographically stratified, meaning that a wide variety of machines are found in a limited area. Second, a primary purpose of ATMs is to permit banking transactions to be performed anywhere, and ATM usage patterns indicate that a significant portion of transactions occur at "foreign" locations. Consequently, it is expected that a typical user will frequently use, at these foreign locations, a variety of ATMs with different designs from any of the several manufacturers.

An initial cursory examination of several different ATM models indicates that control designs, layouts and operating procedures for different ATM models show little or no standardization. The physical layout, types of controls and displays, and the operating software for these units are found to vary widely between models and manufacturers. Figures 1.1 and 1.2 depict typical layouts for some major ATM models.

With the recent widespread proliferation of ATMs, there has apparently not been a comparable increase in ergonomically efficient hardware and software designs.

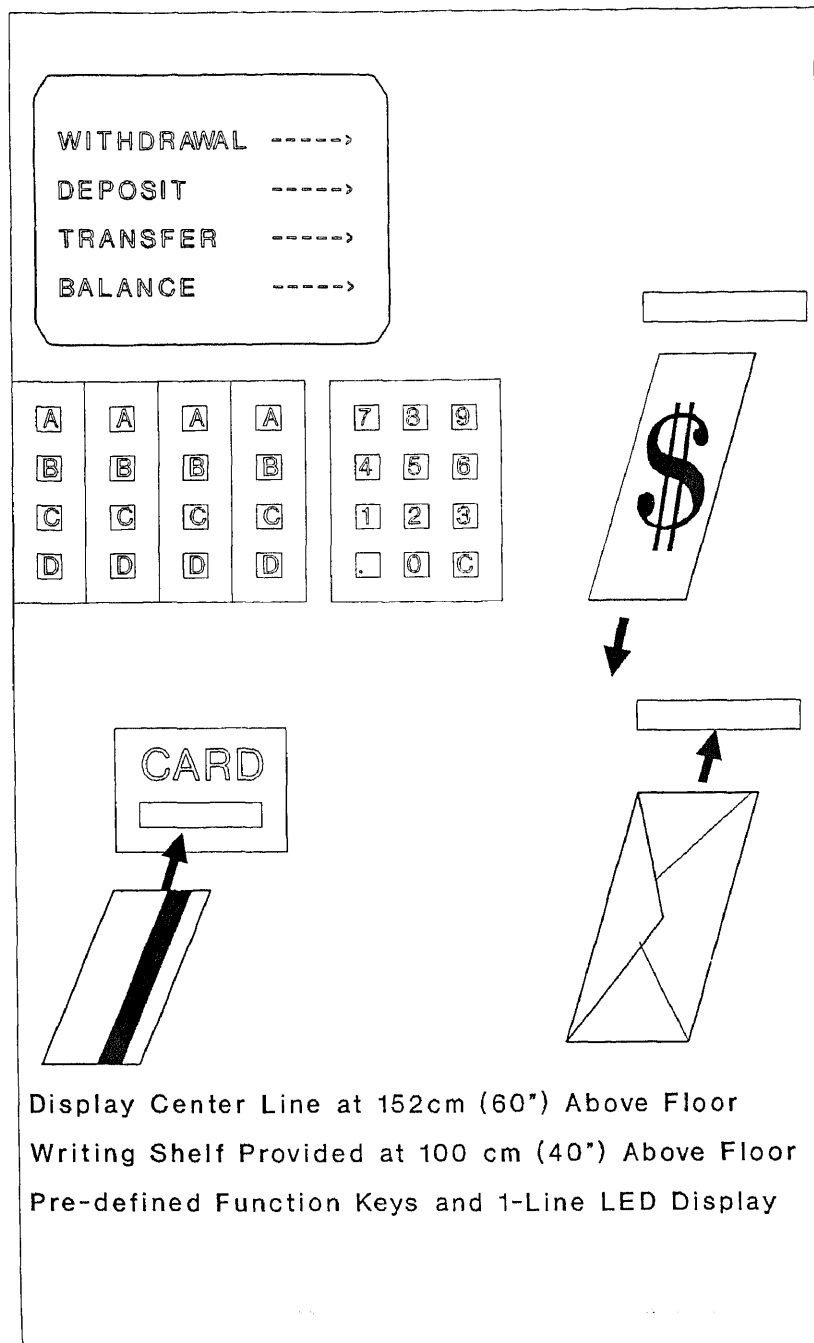

Figure 1.1 Layout for IBM Automated Teller Machines.

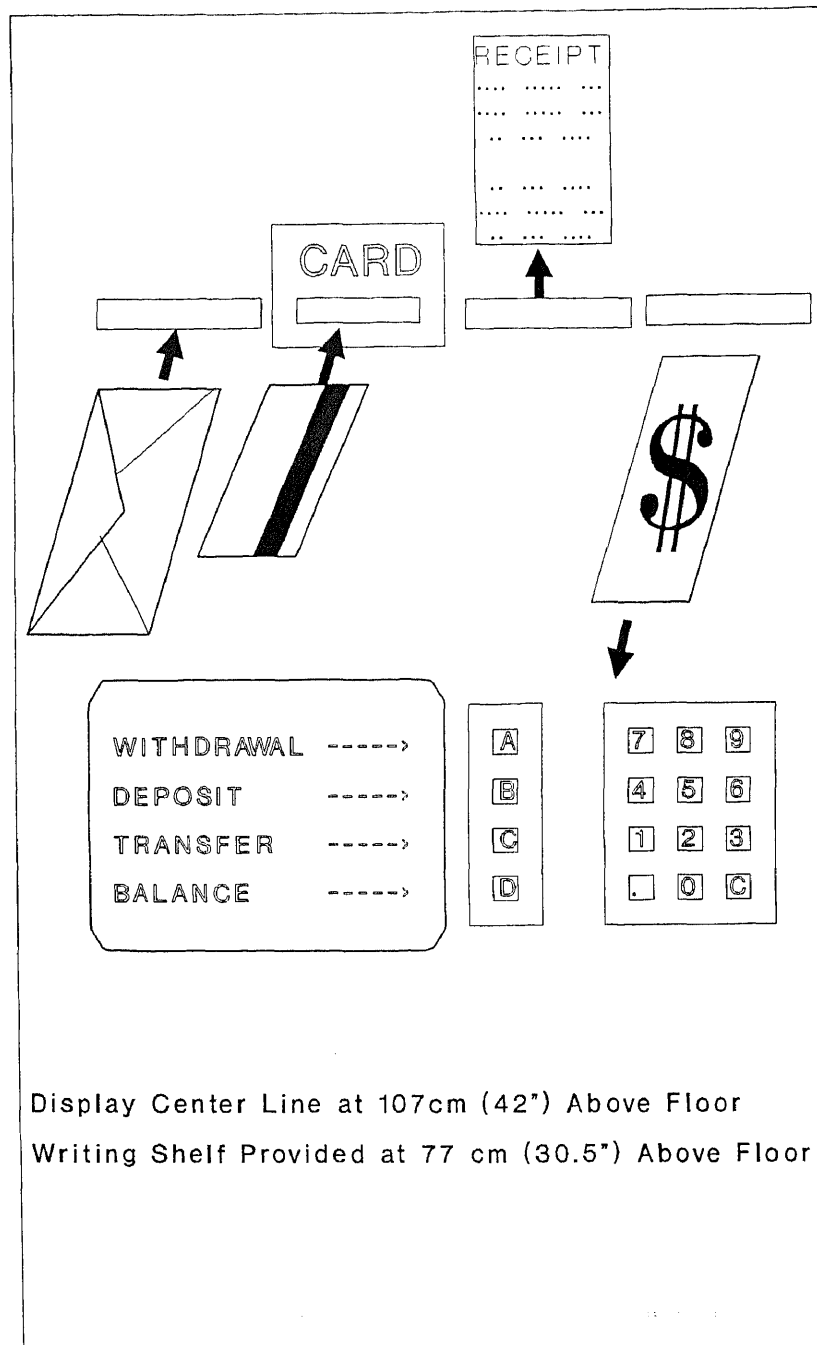

Figure 1.2 Layout for NCR Automated Teller Machines.

The users of ATM machines often find that their productivity level, as well as their satisfaction, is adversely affected by poor workplace design and layout, inconsistent operating procedures, confusing screen displays, and intolerant data entry and error handling procedures. In order to attain the highest utilization rate of the entire ATM system, the performance of operators at all levels must be maximized. Through a proper ergonomic design, performance degradation can be reduced, resulting in higher ATM system utilization, better operator performance rates, and an increase in satisfaction (Haynes, 1990).

The purpose of this thesis is to develop a set of design guidelines for ATMs' hardware and software interfaces by incorporating ergonomic principles. Included in this work are methods for selecting and implementing practical routines to provide optimal or near-optimal layout of ATM control panels, keyboards, and screen displays. In addition, dialog scripts, data entry techniques, fault-tolerant error handling routines, and other practical techniques for improving the software determined aspects of the human-machine interface will be addressed.

With emphasis on physiological, perceptual and cognitive psychological factors, certain quantitative methods are discussed on how to evaluate human-machine interfaces in order to measurably enhance their user friendliness. The developed guidelines can be applied to a variety of human-machine interface design problems.

In the course of studying the ergonomic design of ATMs, various interdisciplinary qualitative and quantitative techniques of analysis and

optimization are employed. It is anticipated that the methods used and results achieved may find wider application in the design and analysis of other types of control panels and work environments in general.

1.3 Sequence of the Discussion

The discussion of the ATM layout procedure that follows will be organized according to the following sequence. First, the ATM layout problem is defined, starting with determination of the expected user population, typical activity sequences, transaction distributions, and other overall system functional specifications.

Next, the overall workstation size and shape is selected based on the practical requirements and the anthropometry of the user population. The problem is reduced to a finite set of feasible control sites, and a basic set of controls is selected in accordance with general ergonomic guidelines.

From the given initial workstation envelope, layouts are defined using various techniques. Several conventional methods for facilities and control panel layout are discussed, such as experimental trial, link analysis, CORELAP, etc. are discussed. The design objective of these methods is generally to minimize the total motion cost, which is defined as the sum of individual inter-control distances (or travel times) in performing a given function.

A methodology is developed which involves the determination of a set of costs as a function of the human body's positions in performing a set of tasks. From the expected probabilities for each type of transaction, and knowing the type of control needed for each transaction, the system is modeled as a stochastic process. By using simple calculations, the limiting behavior - or steady-state condition - of the system is found. From the steady-state solution, an indication of the percentage of time spent by the operator in manipulating each control can be found.

Using established principles of biomechanics, the position cost factor is developed. For each feasible control location, position costs as defined in terms of reduced work capacity will be computed. The sets of joint angles required to reach each point are computed by the technique of inverse kinematics. Given each location's joint angles, and from anthropometric and biomechanics data, a corresponding position cost is derived in terms of predicted endurance reduction.

Once the position cost coefficients are determined, suitable methods are used to find the optimal control assignment. The optimal arrangement is that which minimizes the sum of position costs in performing a specific set of activity sequences.

After the control assignments are made and the hardware design is complete, the emphasis shifts to the software component. Recommendations are offered for providing an efficient operator interface. Types of screen displays and dialog scripts are discussed. A discussion follows concerning the concept of a flexible interface which can adapt to the needs of the user.

Finally, a case study of an ATM design is presented. Intermediate numerical solutions are found using the proposed techniques, and a final design recommendation is proposed.

CHAPTER 2 LITERATURE REVIEW

An analysis of techniques for the design and layout of ATMs suggests that several subject areas be explored. Specifically, literature references are concentrated into the following general areas: systems analysis, workplace and control panel layout, human engineering and biomechanics, operations research, and robotics.

2.1 Ergonomic Design of Workplaces

There has been extensive work done in the area of ergonomic design of workplaces and control panels (Van Cott & Kinkade, 1972; Woodson, 1981; Rodgers et al., 1986). Very few specific reports on the design of ATMs are found in the literature; nevertheless, several studies in related design issues do exist. They are either in the areas of general layout or endeavor to solve specific layout problems in some complex environment, such as an air traffic control center.

2.2 Subjective Layout Techniques

In many cases, control panel designs have been developed solely on the basis of subjective opinion rather than an objective methodology. In the experimental studies of control console design of Morant (1954), a four-step

technique is employed. The procedure, called the "Method of Experimental Trials," can be described as follows. Initially, a mock-up of the workplace to be studied is constructed. Then, appropriate subjects from the user population are selected to perform suitable tasks. Observations of the performance and results are collected in terms of speed, accuracy, etc. Finally, the quality of the console design is determined from the results. A study showing the comparison of four different designs, gives users and evaluators the opportunity to rank them with "preference rankings" from 1 to 4 (Siegel and Brown, 1958). Although some successful layouts have been developed, results have been inconsistent using this technique.

2.3 Heuristic Techniques

Heuristic and quasi-quantitative solutions to the layout problem are found in the literature. Nugent et al. (1968) give an experimental comparison of four techniques for the assignment of facilities to locations. They discuss the difficulties in finding an optimal solution and give examples of the computational efficiencies of various methods of solving problems of small to moderate complexity. A method for assessing the theoretical lower bounds in quadratic assignment problems is proposed by Francis and White (1974). A heuristic to find the approximate solution to the assignment problem is provided by West (1983). Abdel-Malek and Li (1990) used inverse kinematics and an extension of the Traveling Salesman algorithm (Held and Karp, 1970) to find the optimal sequencing of robot tasks in automated work cells.

The computer-aided design of facility and workplace layout based on the inter-element relationships between components is the subject of ALDEP, CORELAP (Lee and Moore, 1967), and CRAFT (Francis and White, 1974). Other computerized techniques include WOLAP (Rabideau and Luk, 1975), PLANET (Apple, 1977), and DISCON (Drezner, 1980). Entire factories and industrial buildings are laid out based on the strength of the associations between functions of the departments comprising them. The cost functions generally are computed from a weighted sum of the center distances between workplace elements. More recent techniques in workplace layout are described in McCormick and Wrennall (1985).

2.3.1 Logical Evaluation Techniques

Bonney and Williams (1977) developed a computer software program, CAPABLE (Control And Panel Analysis By Logical Evaluation), to solve certain simplified control panel layout problems. The problem formulation involves positioning n controls into m available locations, where n is not greater than m , in order to maximize or minimize some objective function. In an example, an objective function is defined to minimize the total distance traveled or time taken to perform a predefined set of tasks. The program enumerates and evaluates all feasible solutions and eventually finds the optimum configuration. However, as the number of controls and locations increases, so does the complexity of the problem in terms of the number of feasible solutions.

Two situations can occur in the control layout problem. First, the number of controls (n) can precisely match the number of feasible locations (m). In this case where $n = m$, the number of feasible solutions will be $n!$. The other case is when the number of controls is less than the number of feasible locations ($n < m$). In this instance, the number of solutions will be $m! / (m-n)!$. It is apparent that, even in greatly simplified problems where n and m are relatively small, optimal solutions may be extremely difficult to obtain by totally enumerating using this algorithm.

Formal techniques for systems analysis and design by breaking down into and processing the elements in the form of lists were described by Phillips (1987). For the operation being studied, the elements are contained in one of two lists - verbs (actions or activities), and nouns (objects or locations) manipulated or visited during operation. Monte Carlo type operational simulations of actions and activities have been applied in order to analyze stochastic systems and to determine statistical results (Metropolis and Ulam, 1949).

There have been attempts to measure quantitatively the accessibility of controls for human operators. By objective evaluation, judgements can be made based on comparisons of various layouts. Banks and Boone (1981) introduced the concept of an "Accessibility Index" as a method for quantifying control accessibility. The index takes into account the operator's reach envelope and the frequency of use of the particular control.

2.3.2 Link Analysis Model

Link analysis is a systematic procedure for studying and planning human-machine and machine-machine systems based on the strength of links between components. The term link refers to "any connection between a man and a machine or between one man and another" (Van Cott and Kincade, 1972). The purpose of link analysis is to optimize the links contained within a system. Link analysis techniques have been employed by Champanis (1959) to assist in the redesign of workplaces in a shipboard combat intelligence center. McCormick (1970) also employed link analysis techniques in the studying of eye movements of pilots. The research led to the increased standardization of arrangements of aircraft instrument panels. Applications of link analysis procedures in control panel layout problems are described in Cullinane (1977). Examples are given of charting and computerized methods for designing the layout of facilities for a computer center.

Link values are established between workplace elements according to the relative frequency of the operator going from one element to another, communication frequencies, and relative importance. Alternative designs are considered by rearranging their locations, redrawing, and recomputing the link values for evaluation (Kantowitz and Sorkin 1983).

A four step procedure is followed in performing a link analysis as follows (Cullinane, 1977):

1. Using symbols, develop a diagram showing all interactions between people and equipment.
2. Examine all relationships and establish link values.
3. Develop a preliminary link diagram.
4. Refine the link diagram and state the final layout.

A relationship chart as shown in Figure 2.1 is created to show the interrelationships of workplace activities. The symbols A, E, I, O, U, and X, entered in the upper triangles describe the link strengths according to the following:

- A: Absolutely essential for the two activities to be located close together.
- E: Essential for the two activities to be close together.
- I: Important that the two activities be close together.
- O: Ordinary closeness is acceptable for the two activities.
- U: Unimportant if the two activities are placed close together, or a link does not exist.
- X: It is undesirable for the two activities to be placed together.

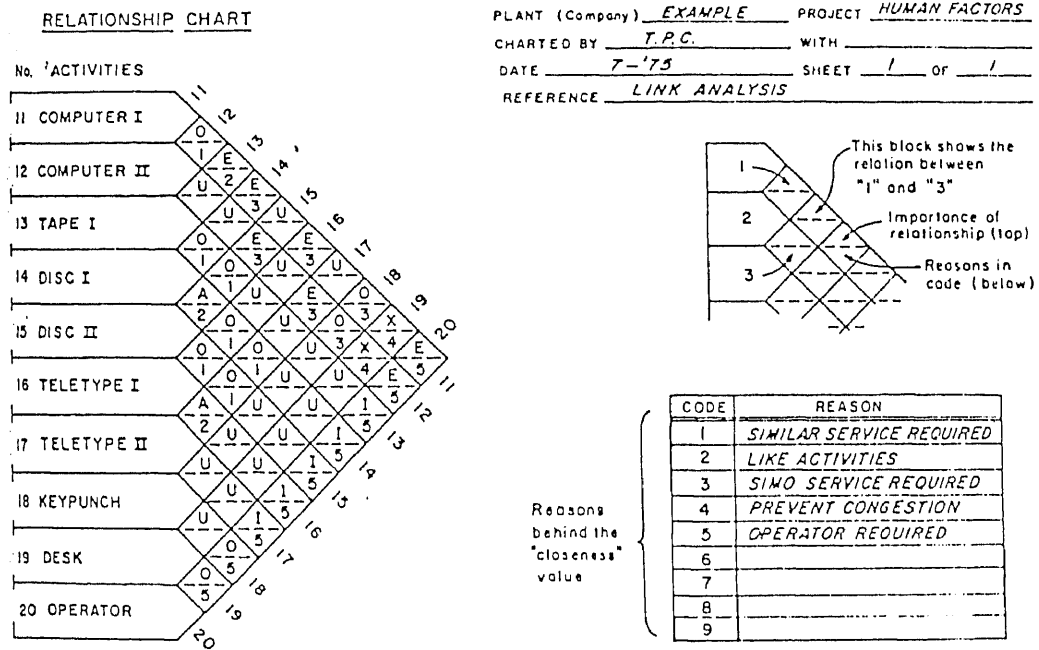

Figure 2.1 Relationship Chart for Link Analysis (Adapted from Cullinane, 1977).

2.4 Quantitative Techniques

Other, less subjective approaches to the layout of control panels and other general layouts have been addressed. An examination of the layout problem in perspective and a methodology for selecting which analytical tools to employ is given in Vollmann and Buffa (1966). An operational guide to the analysis of layout problems is presented as shown in Figures 2.2 and 2.3.

Nedungadi and Kazerouinian (1989) suggests that certain problems may be decomposed, or split into smaller subproblems to facilitate solution. That is, given the set of controls used by each member, heuristic rules are applied and each set optimized. Then, individual results are recombined to obtain a global "pseudo-optimal" which may approximate the exact optimal solution.

2.4.1 Categories of the Layout Problem

Hendy (1989) suggests that there are three basic categories of the layout problem. Category I problems are of such large scale that they are beyond human perception. Examples include the locating of departments within a large facility and the locating of buildings within a geographical area. Category II problems are of moderate scale and within the range of human perception; for example, the layout of a factory department or an office. Category III problems are of small scale and within the immediate range of perception. The layout of operator workstations and instrument panels fall into the realm of

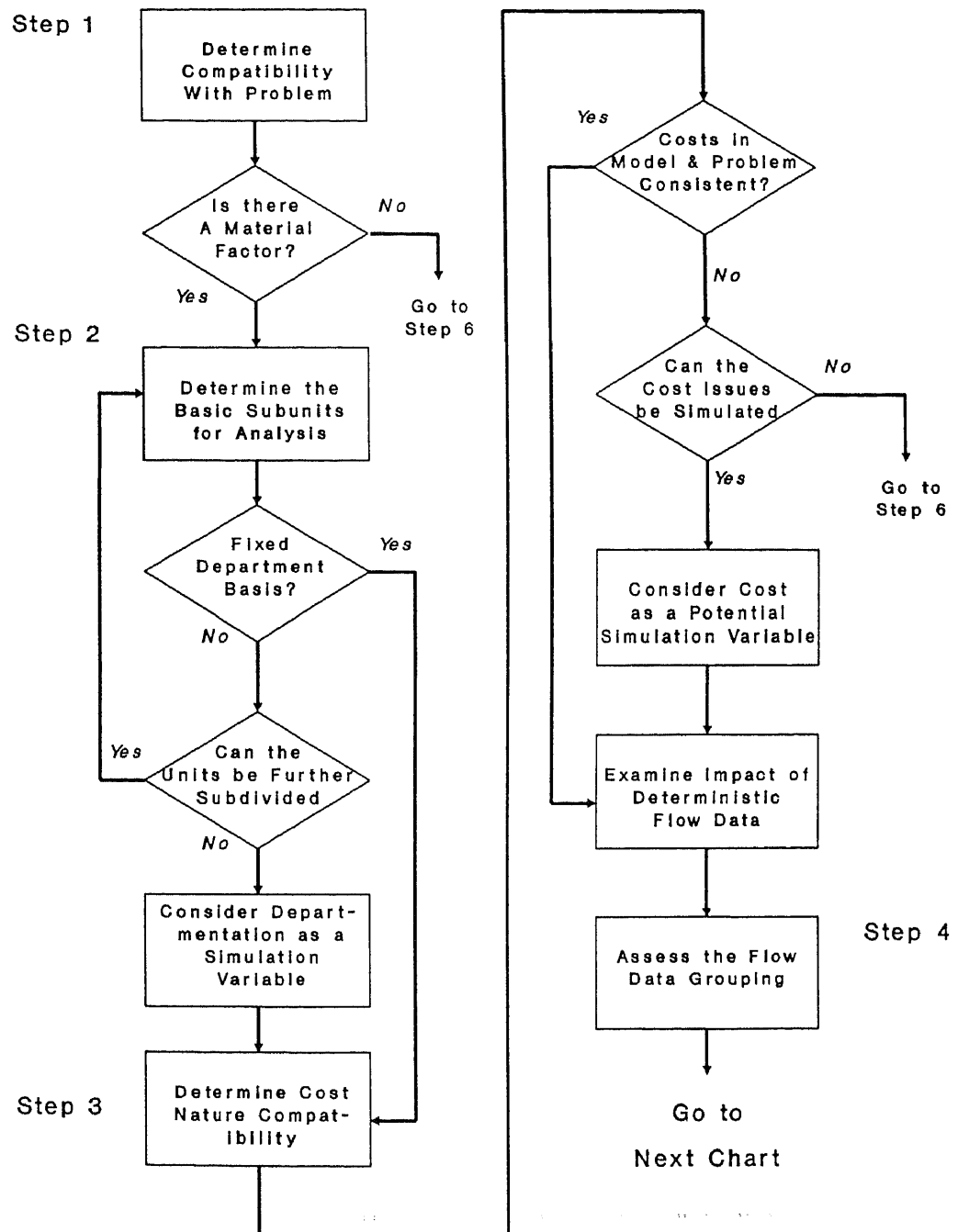

Figure 2.2 Operational Guide to Layout Problems, Part 1. (Adapted from Vollmann and Buffa, 1966).

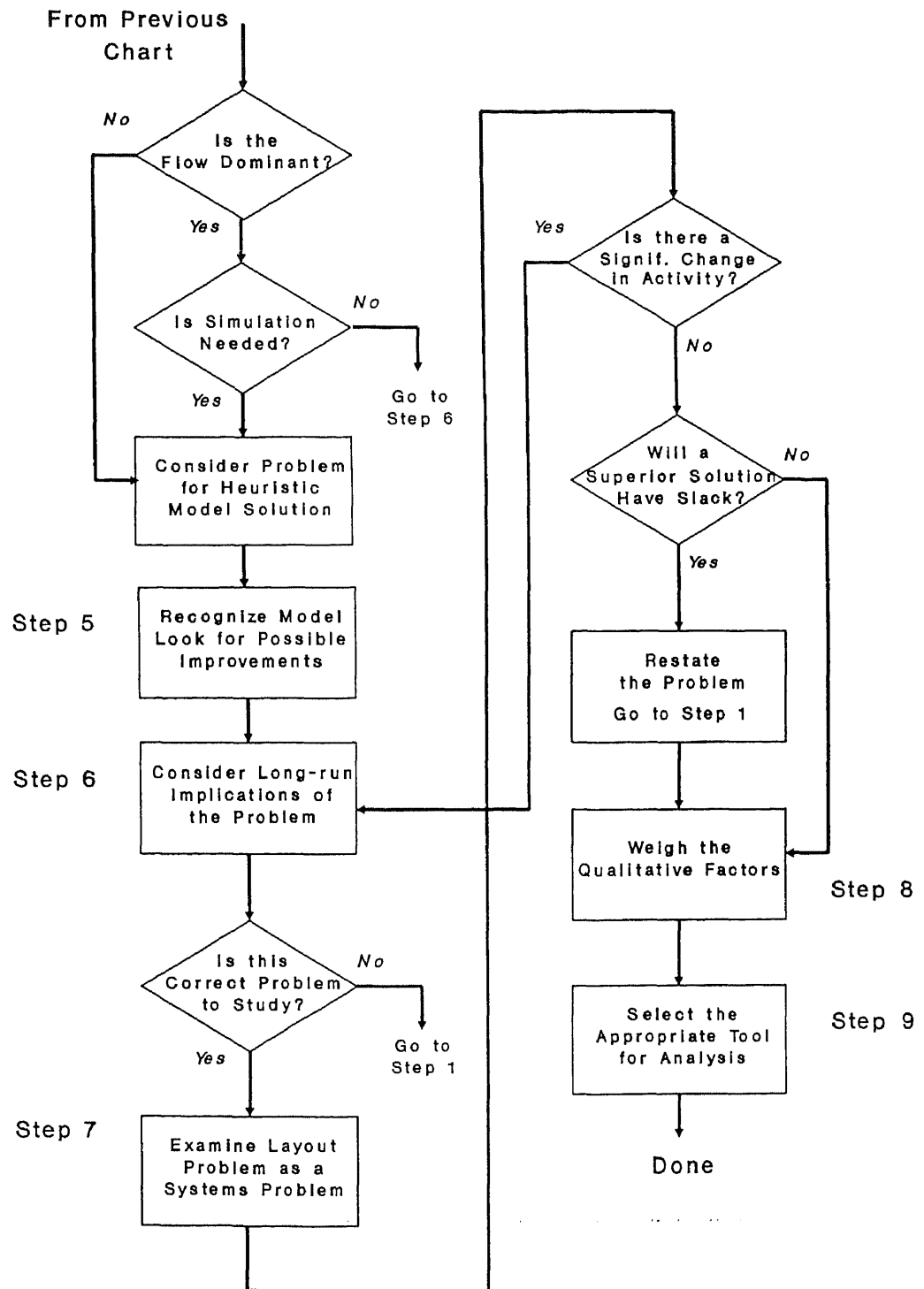

Figure 2.3 Operational Guide to Layout Problems, Part 2. (Adapted from Vollmann and Buffa, 1966).

category III problems. Although in individual situations this may not be the case. In general, category I problems are those in which the costs of transportation from location to location are critical in the decision process; and category III problems are those in which transportation is less significant.

2.4.2 Quadratic Assignment Problem

The problem of assigning m facilities to n locations has been formulated as a quadratic assignment problem, or QAP (Koopmans and Beckmann, 1957). The basic form of the quadratic assignment problem is to find the values of x_{ij} which minimizes the total cost of all assignments, where:

c_{ij} = the cost per unit time associated with assigning work center i to location j .

d_{ij} = the distance from location i to location j , appropriately adjusted to measure the cost of travel from location i to location j .

f_{ij} = the work flow from work center i to work center j .

S_i = the set whose elements are the locations to which work center i may be assigned.

The assumption is made that m is not greater than n , or, for the sake of generality, that $m = n$ since $(n - m)$ dummy work centers can be introduced.

The general format of the quadratic programming model is stated as follows (Hillier and Connors, 1966):

$$\text{Minimize} \quad \sum_{i=1}^n \sum_{j=1}^n \sum_{k=1}^n \sum_{r=1}^n a_{ijk_r} x_{ij} x_{kr} \quad (2.1)$$

subject to,

$$\sum_{i=1}^n x_{ij} = 1, \quad (j = 1, 2, \dots, n) \quad (2.2)$$

$$\sum_{j=1}^n x_{ij} = 1, \quad (i = 1, 2, \dots, n) \quad (2.3)$$

$$\text{and } x_{ij} = 0 \text{ or } 1, \quad (i, j = 1, 2, \dots, n) \quad (2.4)$$

Where:

$$x_{ij} = 1 \text{ if work center } i \text{ assigned to location } j$$

$$x_{ij} = 0 \text{ otherwise}$$

$$a_{ijk_r} = f_{ik} d_{jr}, \text{ if } i \neq k \text{ or } j \neq r$$

$$a_{ijk_r} = f_{ii} d_{jj} + c_{ij}, \text{ if } i=k \text{ and } j=r.$$

The case of infeasible assignments is avoided by assigning a very large number to c_{ij} whenever j is not an element of S_i . Since the goal of the objective function is to minimize Z , infeasible assignments will not be included in the final solution unless the solution itself is infeasible.

There are several quadratic assignment algorithms reported in the literature. Gilmore (1962) and Lawler (1963) present algorithms to find optimal assignments, however their complexity is such that they are computationally feasible for small scale problems ($n < 15$). Several suboptimal QAP algorithms

are available and two versions are submitted by Hillier and Connors (1966). One algorithm deals with the general quadratic assignment problem, and the second deals with the special case in which travel costs are proportional to the rectangular distances between them. The complexities of these algorithms are, respectively, n^5 and n^4 . Other algorithms can find the exact solution to the assignment problem with orders of complexity of n^3 (Lawler, 1976) and $n^2 \log n$ (Karp, 1980). Finding exact solutions to larger scale problems by these methods may still be cost-prohibitive for $n > 15$ (West, 1983).

It has been shown (Hitchings, 1968) that assignment costs follow a normal distribution even in QAP problems as small as $n = 5$. Nanda and Weingarten (1974) suggest that a formula can be used to calculate the statistical parameters of all $n!$ assignment costs without the need for enumerating each one. A heuristic method for assessing the efficiencies of QAP solutions is proposed, based on their percentiles in the normal distribution (Khaopravetch and Nanda, 1990).

2.4.3 Special Cases of the Location Problem

Hillier and Connors (1966) identify two special cases of the facilities location problem.

1. Independent work centers are assigned to heterogeneous locations. For example, the m work centers are unrelated in that no work flows occur between them, and cost is entirely unaffected by their relative proximities.
2. Interrelated work centers are assigned to homogeneous locations. Cost is determined by the relative proximities of the respective work centers, rather than the locations to which they are assigned.

In problems of the first type, costs of work flows are insignificant or nonexistent and the problem can be formulated and solved as a linear assignment problem. It is conjectured that the ATM and certain other control layout problems belonging to Category III (Hendy 1989) can be modeled as a special case (of independent work centers), and solved by linear programming or linear assignment methods.

2.4.4 Linear Programming Problem

A solution to the layout problem based on modeling and solving by linear programming, was found by Freund and Sadosky (1967), who optimized the assignment of 8 control devices into 8 feasible locations. The objective function in this problem was defined as the Utility Cost Rating, and was computed by multiplying the frequency by the accuracy of response. The results show that solution of these problems can be accomplished by several linear programming algorithms. Formulation and solution as a simplex problem was attempted, but the structure of constraints was found to be too complex to be efficiently implemented. Instead, it is recommended that either the transportation algorithm or the assignment algorithm be used (McCormick, 1970).

2.4.5 Stochastic Modeling

Methods of studying systems by stochastic modeling are abundant in the literature. The basic elements of probability theory and some of its applications are discussed in Cramer (1955). The mathematical basis of various operations research techniques in optimization of stochastic systems are given in Saaty (1959). Analytical techniques and solution methods for specific types of stochastic model applications are discussed in Bhat (1984).

2.4.6 Markov Activity Models

A finite number of states and discrete sequences of events can be modeled using an Activity Sequence Generator. The analysis of the sequencing of control activities by their expected sequence of actions was described by Miller et al. (1981). An event-based Markov activity sequence generator was constructed in order to study the tracking behavior and capture times for eye-to-target situations. In a typical Activity Sequence Generator diagram (Figure 2.4), the circles represent the different states of the system (nodes), and the directed paths (arcs) represent internodal transitions between states. The number on each arc denotes the probability of transition from source to destination node, given that the system has entered the source node (Miller et al., 1981).

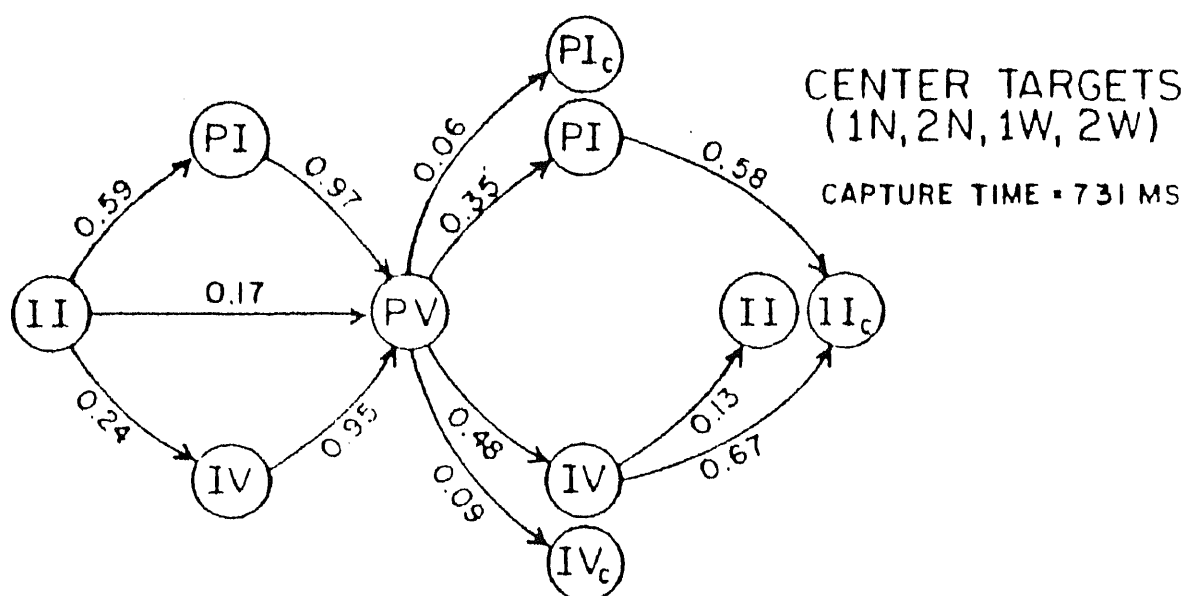

Figure 2.4 Activity Sequence Generator (Adapted from Miller, Jagacinski, Nalavade, and Johnson, 1981).

2.5 Human Factors Research

Purely quantitative methods which solve the layout problem by time or motion minimization are suitable for many applications, such as facilities and department layouts. However, these techniques often do not address the human factors concerns which may dominate in the class of problems of which control panel and other small scale category III layout problems are a member (see Section 2.4.1).

Recommendations for equipment and workplace design have been addressed in the ergonomics and human factors literature. A thorough treatment of the subject and presentation of a set of guidelines for the ergonomic design of equipment is the subject of Van Cott and Kinkade (1972), Rodgers et al. (1986), and Konz (1990). Comprehensive sets of design heuristics based on scientific research have been developed.

2.5.1 Physical Workplace Dimensions

Workplace arrangement guides presented in the literature are used in determining the preliminary physical layout and dimensions of the workplace. The "Human Engineering Guide for Army Material" (Department of Defense, 1981) includes a workspace arrangement guide showing optimal manual control locations for seated operations as shown in Figure 2.5. Recommendations for desired dimensions and shapes for standing workplaces are reported by Woodson et al. (1972). The preferred locations for primary and secondary visual displays,

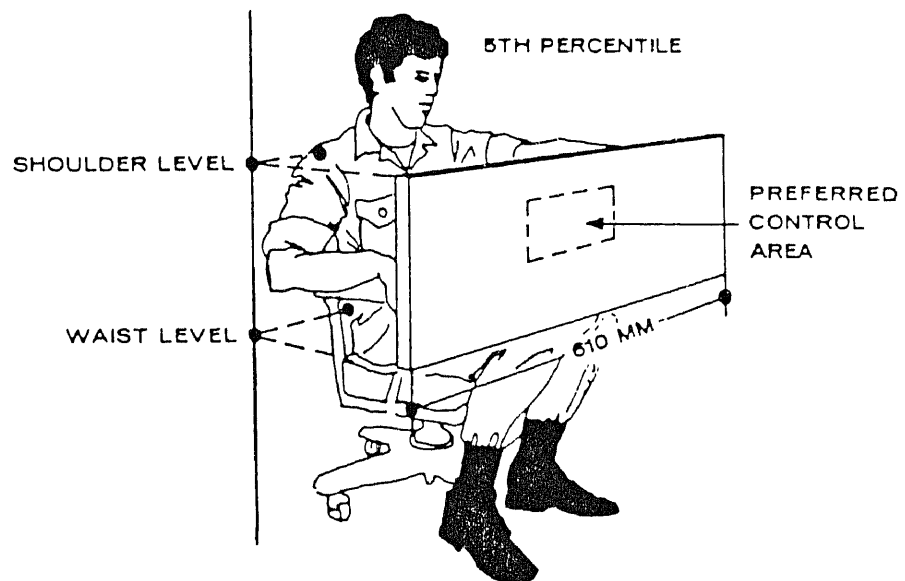
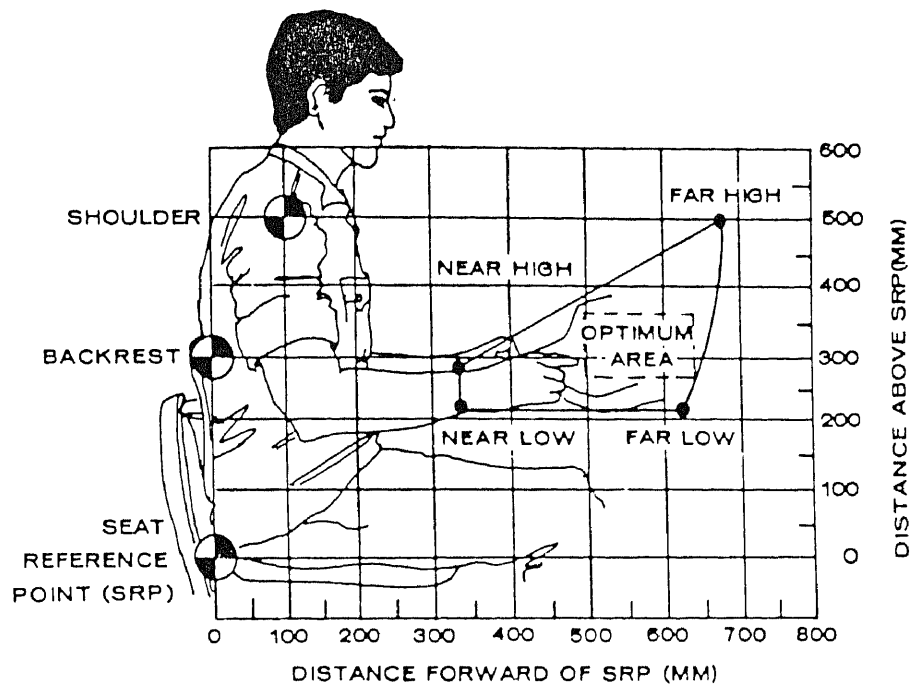

Figure 2.5 Workspace Arrangement Guide for Seated Operations (Reproduced from MIL-HDBK-759A, U.S. Department of Defense, 1981).

keyboards and other operating controls have been defined, with an example of a suggested workplace for a standing operator as given in Figure 2.6. Konz (1990) lists fourteen guidelines for the physical design of general purpose workplaces.

2.5.2 Controls and Displays

Control and display guidelines are available to assist in the selection and specification of controls and displays for operator workstations based on the functions to be performed. The literature in the human factors area also contains numerous references concerning recommended control design. Certain ergonomic physical design parameters such as control type, size, shape, color, spacing, operating force requirement, displacement, feedback properties, etc, have been determined for several specific types of typical controls such as individual push-buttons, keyboards and keypads (Tillmann and Tillmann, 1991).

Ergonomic aspects of push-button switch operators are discussed in Moore (1975). Various types of buttons used in several different applications and methods of operation are covered. In one example it is suggested that buttons for one finger operation should be a minimum of 13 mm (0.5 inches) in diameter with separation of at least one diameter.

The use of arrayed touch screens to simulate full-scope control panels is discussed in the literature. Reason (1989) describes a powerplant application in which six CRTs in a 10-foot space replaced a 24-section bank of conventional controls and instruments. In aircraft flight decks, multiple CRTs and

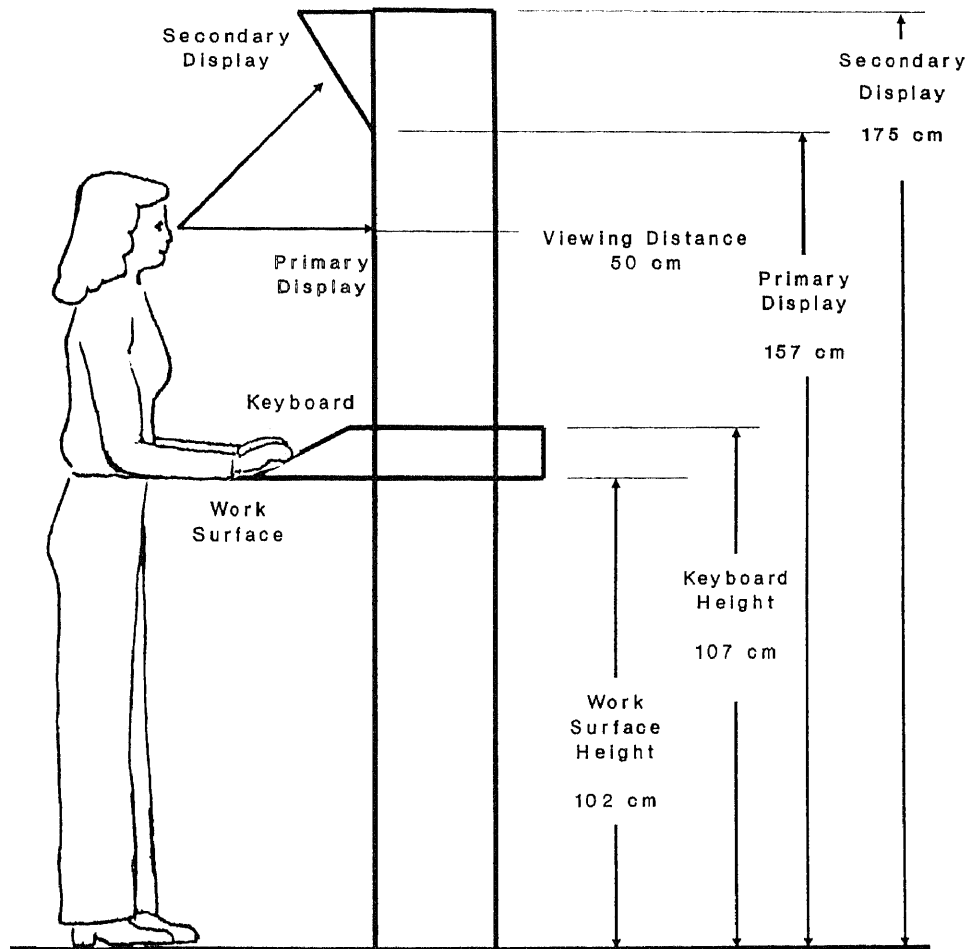

Figure 2.6 Preferred Dimensions for Standing Workplaces (Adapted from Woodson et al., 1972).

sophisticated control display software are being introduced to the "glass cockpits" of the latest generation airliners such as Boeing 747-400 and 777 (Hughes, 1989; Scott, 1991).

2.5.2.1 Keyboards and Keypads

For alphabetic and numeric entries, several buttons are grouped together into keyboards or keypads. The subject of much study, numeric keyset designs typically follow one of two major patterns. The touch telephone numeric keyset has the lowest numbers at the top, while the adding machine numeric keyset has the lowest numbers at the bottom as shown in Figure 2.7. Recommendations regarding the design of push-button keyset are given by Lutz and Chapanis (1955), and Deininger (1960). They state that in most applications the adding machine layout is preferred, since the most frequently keyed numbers are at closer position to the operator.

In both alphanumeric keyboards or numeric keypads, Alden et al. (1972) recommend that key centers should be 19 mm (0.75 in.) apart, and that the key tops should be 12 mm (0.47 in.) square. The force needed to activate the key should be from 0.3 to 0.75 N (1.0 to 2.5 oz.). Additionally, the vertical key displacement may range from 1.3 to 6.4 mm (0.05 in. to 0.25 in.). Membrane keyboards and keypads, suitable for occasional and low frequency applications, are typically flat and have very short displacement, although full-travel raised membrane keyboards are reportedly now available (Bishop, 1980).

1	2	3
4	5	6
7	8	9
*	0	#

Touch Telephone Layout

7	8	9
4	5	6
1	2	3
0		

Adding Machine Layout

Figure 2.7 Numeric Keypad Layouts (Adapted from Lutz and Chapanis, 1955).

Special function keys can provide significantly improved operator performance for advanced users. Function keys can be either hard wired and predefined, or programmable and changeable. Hard wired function keys are simple to implement, but can restrict future upgrades to the system. On the other hand, programmable function keys have the advantage of flexibility; functions can be added or reassigned by changing the software. However, system users, particularly novices, can become confused and irritated if continuity is sacrificed in favor of innovations or "enhancements" of dubious value (Morland, 1983).

In any case where function keys are adopted, they must be clearly identified, either by permanent markings or by nonconfusing screen display legends. Some examples of typical implementations of hard wired and programmable function keys legends are given in Figure 2.8. Improved designs incorporating generally accepted ergonomic principles (Kantowitz and Sorkin, 1983) are also given in Figure 2.8.

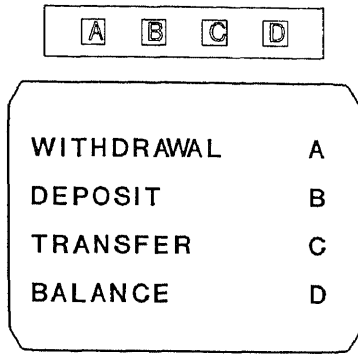

(a) Poor - Inconsistent Control-display relationship

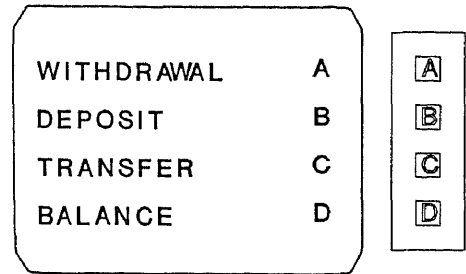

(b) Better - More Consistent

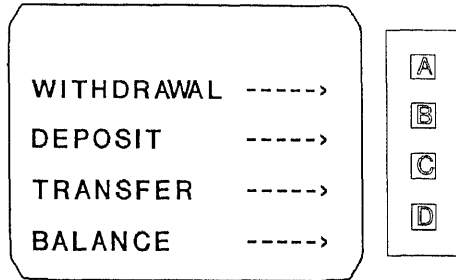

(c) Fair - Consistent relationship but subject to misalignment of displayed characters

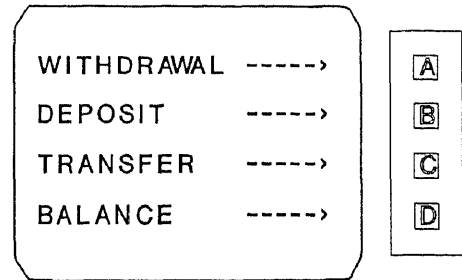

(d) Improved - Realignment of the screen display with controls by field service adjustment

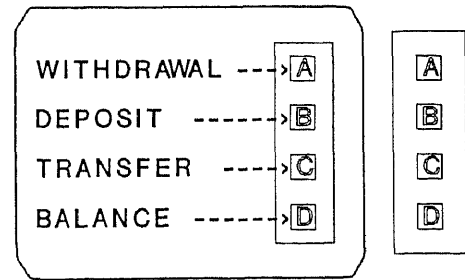

(e) Better - Legend graphics in display - immune to misalignment, but a slight increase in mental workload demands

Figure 2.8 Display Legends for Function Keys.

2.5.2.2 Video Display Terminals

Basic design rules for video display terminals (VDTs) are available. First, the VDT display color is considered. The human eye sensitivity is greatest for light with a wavelength of around 555 nanometers (nm). Therefore, a green (550 nm) display color is preferred over an amber (600 nm) color, according to Willeges and Willeges (1982).

After the display color is established, the optimal spacing between pixels can be found. The pixel diameter (d) is found according to the formula:

$$d = 1.22 \lambda \cdot V / D \quad (2.5)$$

where:

d = pixel diameter

λ = wavelength of light

V = viewing distance (eye to display surface)

D = eye diameter (from anthropometric data)

In a typical case with light of 550 nanometer (nm) wavelength, a viewing distance of 500 mm, and an eye diameter of 0.6771 mm, the formula in Equation 2.5 gives the preferred pixel diameter of 0.54 mm (Willeges and Willeges, 1982).

2.5.2.3 Character Displays

The preferred specifications for the characters displayed on VDTs have been reported. Minimum character height should be 3.0 mm, width should be 2.1 mm, and stroke - or thickness of lines forming the characters - should be 0.45 mm. The characters ideally should be spaced 0.9 mm apart, with 3.0 mm to 4.5 mm (100 to 150 percent of character height) between lines (Willeges and Willeges, 1982).

Konz (1990) reports that character text displayed on VDTs is more readable if the lines are double-spaced and unjustified (ragged right). Reading speeds are found to be improved by a factor of 11 percent over single-spaced text and lines with flush margins.

Tullis (1983) recommends four rules for formatting VDT screen menus:

1. Minimize frame density - fill no more than 25 percent of the available screen positions with characters.
2. Provide spacing between items with blank spacing - double-space text and separate groups by 3 to 5 spaces.
3. Group related items together.
4. Minimize layout complexity - left justify words, right-justify numbers on the decimal, and display lists either alphabetized or in priority order.

2.5.2.4 Video Display Viewing Angle

The literature references describe the preferred viewing angles of visual displays with respect to a "standard" or "normal" line of sight. Van Cott and Kinkade (1972) propose that primary displays be located within 15 degrees of the normal line of sight (10 degrees below the horizontal). Woodson (1972) and Woodson (1981) suggests that visual targets be placed between 10 degrees above and 20 degrees below the normal line of sight (declined 10 degrees below horizontal). The military standard for equipment design defines the normal line of sight as 15 degrees below the horizontal, with preferred viewing angles between +15 and -15 degrees of that line (U.S. Department of Defense, 1981). Another recommendation for "optimal eye rotation" (McCormick and Sanders, 1982) is within 15 degrees above or below the normal sight line (declined 15 degrees below horizontal). Experimental determination of preferred line of sight (Hill and Kroemer, 1986) confirms that (at 1.00 m) the normal viewing angle should be 30.1 degrees below the horizontal anthropometrically defined Frankfurt plane (Figure 2.9).

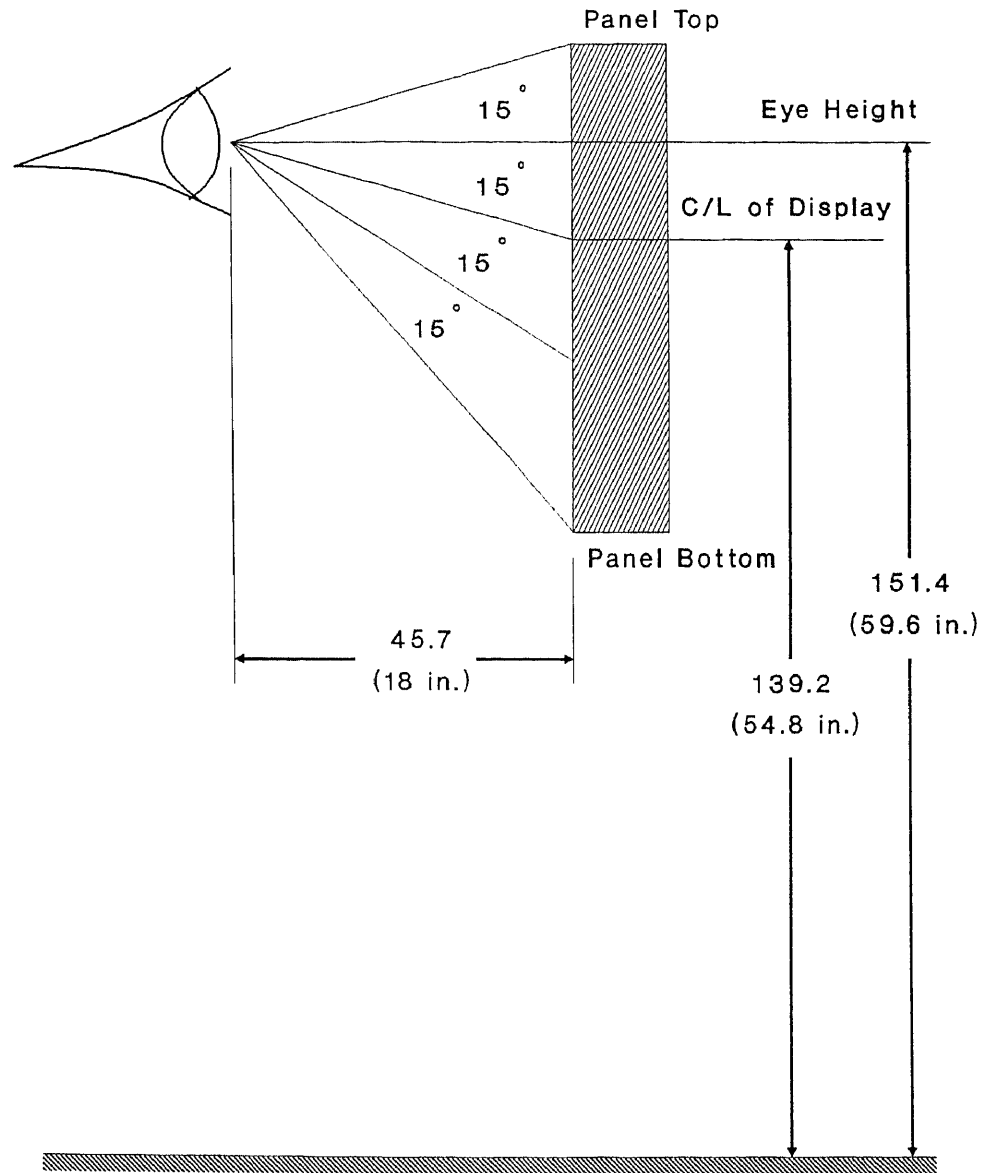

Figure 2.9 Preferred Viewing Angles (Adapted from Van Cott and Kinkade, 1972; Woodson, 1972; Woodson, 1981; U.S. Department of Defense, 1981; McCormick and Sanders, 1982; and Hill and Kroemer, 1986).

2.6 Ergonomics and Biomechanics Research

The problem of determining workplace design standards from the viewpoints of biomechanics and human work endurance has been addressed in the literature. The biomechanical basis of ergonomics is the subject of Tichauer (1978).

Experimental work on muscle fatigue and endurance versus the workload levels was done by Rohmert (1960), and confirmed by Hayward (1975). The relationship between work endurance and level of applied muscular stress was stated by Simonson and Lind (1971) and Morton (1987). They report that endurance time for an activity can be stated as a function of the percentage of the activity's maximum muscular capacity.

Caldwell (1962) conducted experimental studies to determine the effects of various body positions on the maximum force applicable to a hand control. The results show that body postures and joint angles are major factors in the production of usable muscle forces. Various anthropometric studies by Parker and West (1973) and Roebuck et al., (1975) have provided much detailed data regarding the human body and its muscular strength and endurance capabilities. Wiker et al., (1989) discuss the effects of nonpreferred arm locations on human movement, reach, and positioning capabilities. They conclude that the significant posture-based decrements in performance were found to be independent of the strength capabilities of the individual subjects studied.

Strength is defined as "the maximal force muscles can exert isometrically in a single voluntary effort" (Kroemer, 1970). In isometric exertion, the length of the muscles is kept constant during the period of muscle contraction. When the muscle lengths do not change, the body segments remain motionless and a static condition exists. Static measurements of human strength are limited to a period of less than 10 seconds to eliminate the effects of muscular fatigue.

The experiments of E. A. Mueller in the 1930's show that the endurance time depends on what fraction of the exerable force is required. This relationship is also demonstrated by Caldwell (1962) and Caldwell (1964). Figure 2.10 depicts the nonlinear relationship between time and functional strength. While maximal strength (by definition) can be maintained for only 10 to 15 seconds, less than 15 to 20 percent of total strength can be maintained for an "indefinite" period (Kroemer, 1970). Experimental studies of physiological responses and endurance times have been performed for lifting with leg muscles (Genaidy and Asfour, 1989; Genaidy, et al., 1990), and for prolonged arm lifting (Asfour, et al., 1991); showing that responses over short durations were not significantly different from those over longer durations.

Human biomechanical models are developed by Chaffin (1969), in which forces and torques are calculated for a three-link representation of the human arm. The validity of techniques for modeling worker strengths is confirmed by Chaffin, et al., (1987). The biomechanical model of the human arm, and arm movement capabilities are presented by Wiker, et al., (1989). A computerized 3-D biomechanical model is used to predict static strength and to determine the segment of the population able to perform a given task (Chaffin and Erig, 1991).

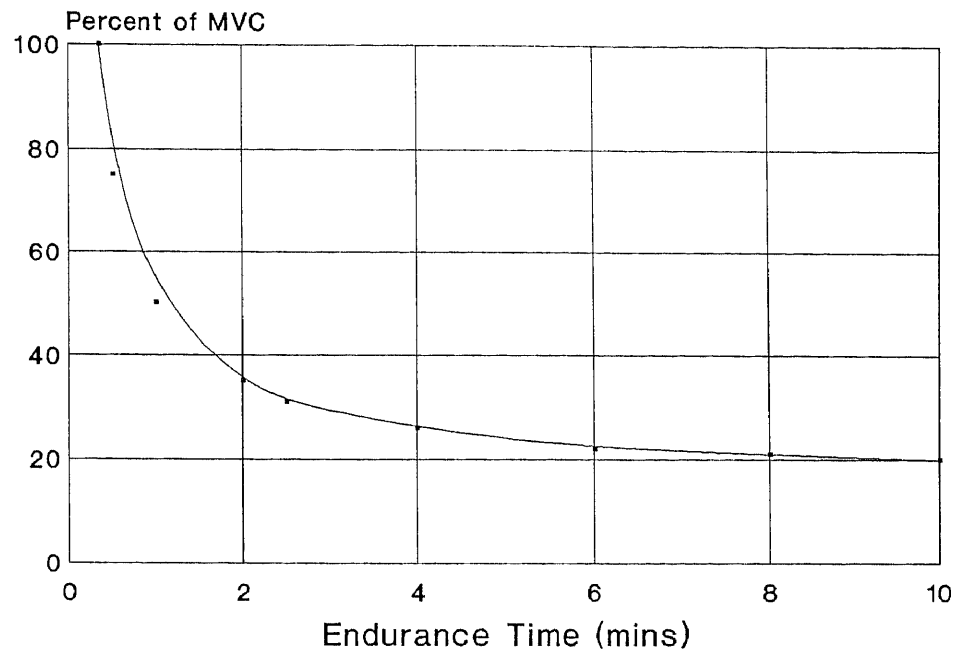

Figure 2.10 Muscular Strength and Endurance Time (Adapted from Kroemer, 1970).

2.7 Analysis of Manipulator Systems

A strictly mechanical analog to the human operator is a robotic manipulator system. A method of representing coordinate systems for multiple link manipulators is described by Denavit and Hartenberg (1955), in which a 4 x 4 homogeneous transformation matrix is established to represent each link's coordinate system with respect to the previous link's coordinate system, beginning at the base and continuing until the end effector is reached. The description of robot coordinate systems and transformations and generalized techniques of solution are attempted by Paul (1981) and Paul (1982). The mathematical analysis of the robot arm based upon direct and inverse kinematics and dynamics is given by Lee (1982). A simplified solution method for specific robot configurations such as the six degree-of-freedom PUMA robot is included. Improved methods for solving the general inverse kinematics problem are given by Goldenberg (1985). Other techniques and simplified algorithms for motion planning and control for certain robots are described by Schwartz and Sharir (1988).

2.8 Software Ergonomics

Software design guidelines are available to detail how computer software should interact with human operators. The topic of software ergonomics is widely addressed and covered in literature from the fields of computer science and human factors. A comprehensive set of human factors guidelines for the design

of computer terminal interfaces is provided in Morland (1983). Strategies for assigning system defaults are proposed and the new concept of statistically generated default values is discussed. The advantages and disadvantages of predefined and programmable special function keys are described.

2.8.1 Response Time

A very important factor in the human-machine interface is the response time. Response time is defined by Martin (1973) as "the interval between the operator's pressing the last key in the input operation, and the terminal's displaying the first character of the response." Desired response times for human-computer interactions are given by Miller (1968). While a response time of more than 15 seconds (common in data communications) is acceptable in noninteractive mode, and between 4 and 15 seconds may be tolerable, it is preferred to have a maximum of 3 seconds, and ideally below 2 seconds.

Conversely, it is suggested that a response time that is too short (less than 0.1 seconds) can also be psychologically bad, and built-in delays of 1 to 1.5 seconds are sometimes implemented, but artificial delays are not often needed on real world systems involving telecommunication (Martin, 1973).

It is also imperative that the standard deviation of response times on a system not be too high (Martin, 1973). Consider, for example, two systems with an identical mean response time of 2.5 seconds. If the first and second systems have standard deviation of response times of 0.5 and 3.0 seconds, respectively, it is

conceivable that an operator of the second system will occasionally have to wait 10 seconds, when he is accustomed to waiting only 3 seconds. This variability can cause the operator to become anxious and even wonder if the machine is working properly.

2.8.2 Computer Dialogues

The design of human-computer dialogues is addressed by Martin (1973). The human-computer conversation is comprised of several pairs of transactions consisting of a statement or question, followed by a response. All transactions are either operator-initiated or computer-initiated interchanges. The structure of screen conversation in human-machine interfaces is discussed and number of distinct display techniques are illustrated. The first eight methods listed below are operator-initiated, and the remainder are computer-initiated techniques.

1. Simple query - no conversation
2. Mnemonic techniques - memorizing logical codes
3. English-language input - parsing technique
4. Program-like statements - high level language
5. Action code systems - action prefix / function key
6. Multiple action codes per entry - multi-function
7. Screen edit - building up a record on the screen
8. Scroll technique - multiple screen edit
9. Simple instruction - one request at a time
10. Multiple instructions - several requests

11. Menu selection - choose 1 item
12. Multiscreen menu - (go to next screen)
13. Telephone-directory - choose from alphabetic list
14. Multipart menu - several menus on one screen
15. Multianswer menu - several answers on one menu
16. Displayed formats - enter date (mm/dd/yy)?
17. Variable-length multiple entry - (date: _____)
18. Multiple-format - choice of (mm/dd/yy), (mm-dd-yy)
19. Form-filling - fill in blanks (_ _ - _ _ - _ _)
20. Overwriting - accept default data or type over it

The choice of which method to use in designing a human-computer interface depends on the job requirements and skill level of the anticipated users. Although more than one technique will sometimes be used on one system, it is desirable that all methods for a given user be similar so as to lessen confusion.

For the operator-originated interactions, the free-form techniques of input (methods 1, 2, 3, 4, 7 and 8) are most suitable for expert or experienced users. For inexperienced to moderately advanced users, the action code methods (techniques 5 and 6) are preferred.

For computer-initiated interactions, the more complicated input displays (methods 16 through 20) may give satisfactory results with expert users. Intermediate to advanced users can effectively use the advanced menu types of techniques 12 through 15. Simple menu selection (technique 11) is generally

recommended for novice users, although productivity is lowered for all groups using this technique (Martin, 1973).

The screen interface should be laid out to match stereotypical expectations, consistent throughout, with predefined input, menu and message areas. Complete feedback should be provided at all times, indicating the status of the system, and suggested actions in lieu of tersely worded error messages.

2.9 Human Anthropometry and Capabilities

Human size and capability data is reported in Van Cott and Kinkade (1972), Parker and West (1973), NASA (1978), and Rodgers et al. (1986). Tables and charts are provided showing physical dimensions, movement range, and human cognitive and perceptual skills for various subject populations. Modeling the human operator in performing computer data entry procedures is the subject of Willeges and Willeges (1982). Expected error rates for data entry operators of varied skill levels are reported by Rodgers et al. (1986). Concepts specifically related to keyboarding are covered in Montgomery (1982).

Research in operator proficiency analysis for operators of varying skill levels has been performed. Gilb (1977) discusses estimated input error rates for various entry lengths and states that, with arbitrary four-digit numbers and no defaults, errors were experienced at the rate of 10 per 1000 entries. In another laboratory study of error rates for keyboarding, Rodgers et al. (1986) reports on average rates for raw and self-corrected errors for both experienced and

inexperienced operators. It is stated that experienced operators made from 1 to 4 errors per hundred, that 70 percent of raw errors were self-corrected, and that inexperienced operators typically had error rates of five to ten times those of experienced operators.

Much information can be found by analyzing the user's individual keying pattern. Weinberg (1965) discovered that by timing keystrokes and combinations of keystrokes, a timing signature can be found to indicate the proficiency and possible even the identity of a user. In addition, changes in keying times during input (blips) can be used to discover errors or poorly designed procedures (Gilb, 1977).

2.10 Automated Teller Machine Studies

Research with respect to Automated Teller Machine usage is reported in literature devoted to banking and finance. Studies have been performed to find the distribution of transaction types, to track weekly ATM usage, and to determine the characteristic transaction patterns of typical users of ATMs (van der Velde, 1982). An analytical approach to determine ATM system and transaction costs is given by Martin and Clark (1982). An assessment of the productivity of current ATM systems is given by Haynes (1990), who reports that, after considering all costs, a typical ATM transaction can theoretically cost the financial institution as little as \$0.07, while the same transaction executed by a live teller costs \$1.15. In addition, studies have shown that the typical ATM system is

used by only 33% of potential users, and that system utilization factor is only 14%.

Other research on the demographic characteristics of the population of expected ATM users is reported in the literature. It is suggested that there are three categories of ATM users: non-users, inactive users, and active users, based on the number of ATM transactions per month. Non-users are defined as banking customers who never have, and, unless no alternative exists, never will use an ATM. Inactive customers make casual use of ATMs up to 2 times per month. Active users perform more than 2 transactions per month (Taube, 1988). According to Haynes (1990), non-users have no ATM activity, inactive users average 1 transaction per month, while active users can average 20 or more. The segmentation of the three classes of the banking represents an extreme example of the Pareto principle, since as much as 90 percent of the activity is generated by 1 percent of the users.

Bayes' theorem is applicable to the problem of estimating the probabilities of individuals being in one of the three categories - given that they belong to one of the population subgroups (Drake, 1967). The probability of belonging to each user class is reported in the literature for several demographic groups (Taube, 1988). The additional data to perform Bayesian analysis - population distributions by age, sex, level of education, and income level - are reported by the U.S. Bureau of the Census (1990).

CHAPTER 3 PRELIMINARIES

3.1 Overview of Workstation Design

The objective of workplace design is to provide a human operator a workplace in which one can efficiently and effectively perform with a minimum level of fatigue and discomfort. There are many guidelines to consider in the design of workplaces. Konz (1990) describes fourteen guidelines for the physical design of general purpose workplaces. The workstation guidelines are as follows:

1. Avoidance of static loads and fixed work postures.
2. Reduction of cumulative trauma disorders.
3. Setting of the work height.
4. Providing proper seating.
5. Use of both foot and hand operations.
6. Use of gravity assists.
7. Conservation of momentum.
8. Use of two-hand motions.
9. Use of parallel motions.
10. Use of rowing motions.
11. Define elbow pivot motions.
12. Design for the preferred hand.
13. Keeping arm motions in the normal work area.
14. Design for the user population.

The ergonomic design guidelines stated by Konz apply to the industrial workplace in general. However, the ATM workstation problem has certain characteristics, such as short duration, non-repetitive tasks, etc., which will require some guidelines to be emphasized while others could be discounted. Of the fourteen guidelines; numbers three, and eleven through fourteen will be stressed. Of greater importance in the ATM design problem, they can be directly applied to the problem of interest.

- * Setting of the work height
- * Primary use of elbow pivot motions
- * Using the preferred hand
- * Keeping arm motions within the normal work area
- * Let the small woman reach; let the large man fit

These considerations will all be addressed in the physical workplace design that follows. The selection and physical layout of a workplace can be achieved by developing a set of techniques for describing a hypothetical design, reducing the designs to a manageable number, analyzing and quantifying them, and finally selecting the optimal design from the subset using heuristics and other tools from the field of operations research.

In systems analysis, it is helpful if a large and complex problem can be divided into smaller and simpler components. Similarly, when considering the human-machine interface in a computer-related device such as an ATM, we can logically partition the overall design problem into hardware and software

elements. The hardware elements include the control buttons, keyboard, display, and other components and their arrangements.

3.2 Hardware Control Specifications

In studying the hardware elements of a control panel, there are several design parameters to be considered. The first concern is the design of the control itself. It is well established that the type, size, shape, and spacing of a control device are important constituents in the overall ergonomic design. By specifying the appropriate control which is properly sized and spaced for human operators, improvement of the final design in terms of high operation rates and low error rates can be achieved. The operational requirements for a control include:

- * Accessibility
- * Ease of Use
- * Freedom from Errors

3.2.1 Control Accessibility

Attention should be paid to the location of the control buttons with respect to the operator. The spatial position of each control plays a major role in the ergonomic efficiency of the overall design. A control button which is improperly placed within the work envelope can increase cost of operation in

terms of higher operation time and operator fatigue. The placement of individual or panels of buttons should take into account anthropometric data and the position taken by the operator in performing the task.

3.2.2 Ease of Use

All control buttons must be chosen and spaced with the objective of easy and efficient operation. The size, key travel distance, and operating force of the button are to be considered. The manner of operation is considered including frequency of operation and possible hindrances to the operator (such as operation while wearing gloves).

3.2.3 Freedom from Errors

In the operation of push-buttons two primary error types can be committed. Type I, or selection errors occur when the wrong button is depressed when another was desired. The type II category of errors are inadvertent operation errors, in which a key was accidentally hit when no other was desired.

Errors of the first type are typically caused by misidentification due to inadequate coding or labeling, although inadequate physical layout may contribute as well. Errors of the second type, inadvertent operation, are almost always the result of improper placement of controls. Accidental multiple

operation can be caused by lack of input confirmation (feedback), a slow response time, or a too rapid key repeat rate.

3.3 Human Factors in Button Selection

In designing and selecting push-buttons, several human factors concerns are to be considered.

- * Physical parameters
- * Coding and Labeling
- * Feedback
- * Panel Design
- * Panel Position
- * Standardization
- * Stereotypes

3.3.1 Control Physical Parameters

The physical parameters of control buttons include size, shape, separation, operating force, displacement, and feedback. The recommended guidelines for physical parameters vary based on type of application and how the button is to be operated. A list of the push-button design recommendations is given in Tables 3.1 and 3.2.

Table 3.1 Recommended Physical Parameters for Push-Buttons for Various Modes of Operation.

Mode of Operation	Diameter Min	Key Travel		Resistance		Separation	
		Min	Max	Min	Max	Min	Preferred
One Finger Random	1.3 cm	0.3 cm	0.6 cm	283 g	1133 g	1.3 cm	5.0 cm
One Finger Sequential	1.3 cm	0.3 cm	0.6 cm	283 g	1133 g	0.6 cm	1.3 cm
Different Fingers	1.3 cm	0.3 cm	0.6 cm	140 g	560 g	0.6 cm	1.3 cm
Thumb	1.9 cm	0.3 cm	3.8 cm	283 g	2272 g	2.5 cm	15.0 cm

Adapted from Alden et al. (1972), and Moore (1975).

Table 3.2 Recommended Physical Parameters for Push-Buttons for Selected Applications.

Type of Application	Diameter Min	Key Travel		Resistance		Separation	
		Min	Max	Min	Max	Min	Preferred
Industrial Push Button	1.9 cm	0.6 cm	3.8 cm	283 g	2272 g	2.5 cm	5.0 cm
Car Dashboard Switch	1.3 cm	0.6 cm	1.3 cm	283 g	1133 g	1.3 cm	2.5 cm
Calculator Keypad	1.3 cm	0.3 cm	0.3 cm	100 g	200 g	3.0 cm	3.0 cm
Typewriter Keyboard	1.3 cm	0.08 cm	0.47 cm	26 g	152 g	0.6 cm	0.6 cm

Adapted from Alden et al. (1972), and Moore (1975).

From these guidelines, specific requirements for each application must be considered in order to select appropriate design specifications. For example, it is suggested that if gloves are worn, separation of buttons must be increased from a minimum of 25 mm to 50 or even 100 mm apart (Moore, 1975).

3.3.2 Coding and Labeling

Coding is the feature of a display or control which enhances its identification to the human operator. Coding features are incorporated into the design in symbolic form (words), representative form (pictures), or physical form (color, etc). Among the guidelines for coding of push-buttons are the following factors:

- * Detectability
- * Discriminability
- * Compatibility
- * Symbolic Association
- * Standardization

The requirements for detectability and discriminability can be met by providing adequate size, color, and labels. Compatibility with human expectations is achieved by using spatial, movement, or stimulus/response combinations which are consistent with the functional characteristics of the desired action. Symbolic association adds to compatibility by using common symbols which are associated with the control's function. Standardization of

coding is important since different individuals will often be interpreting the coding methods used in different versions of similar equipment.

3.3.3 Feedback Characteristics

Feedback is the property of a push-button which provides the operator with the immediate results of his or her actions. The information often originates directly from the action of the button itself in the form of a tactile or audible click. Additionally or alternately, the system can electronically provide feedback by either generating a beep, rapidly changing the visual displays to the operator, or both.

3.3.4 Standardization

In the ideal case, coding, layout and locations will follow established standards. In reality, however, this standardization is limited at best. In machines which perform similar functions and operated by the same user population, lack of standardization is frequently observed. For example, a calculator keypad and telephone touch tone keypad follow entirely different layout schemes. An accountant who is skilled at using the calculator keypad arrangement may, when unconsciously dialing, reach wrong phone numbers. It would obviously be preferable if standards were established and adopted by manufacturers of similar equipment.

3.3.5 Stereotypes

Population stereotypes for push-button design and coding should be followed whenever possible. In cases where designs violate existing stereotypes, it is necessary to provide careful instruction and training to overcome situations where the same stimuli requires different responses. Using stereotypical expectation will serve to reduce both operator training times and error rates.

3.4 Control Proximities

The manner of operation of a particular set of tasks will determine the relative positions of control buttons within the workplace. For example, certain related controls can be located adjacent to each other and unrelated ones apart based on their function. Logical placement of controls with respect to each other can result in reduced travel distance, hence lower time and motion costs.

3.5 Input Error Rates

It cannot be assumed that human data entry procedures will proceed flawlessly. Even in performing simple keying tasks, it has been found that the level of experience has a drastic effect on error rates. It is believed that the inexperienced operators make five to ten times as many errors as experienced ones. Laboratory studies have shown that the percentage of raw errors made by experienced operators are typically between 1 and 4 percent, with an average of

2.2 percent. A reasonable estimate of the raw error percentage for novice users (the worst case) is thus given by:

$$(0.022) \times 5 = 0.11 \quad (\text{raw keying error rate}) \quad (3.1)$$

Given that an estimated 70 percent of raw errors are self-corrected (Rodgers et al., 1986), an inexperienced user population would have a net error percentage (uncorrected error percentage) given by:

$$(0.011) \times 0.3 = 0.033 \quad (\text{net keying error rate}). \quad (3.2)$$

As a result, and assuming independence of activities, the novice error rate for the task consisting of keypad input of a four-digit Personal Identification Number (PIN) can be estimated according to:

$$(4) \times 0.033 = 0.132 \quad (\text{keypad task error rate}). \quad (3.3)$$

According to industry statistics, the average ATM transaction amount to be entered at the keypad is \$66.06 (Van der Velde, 1982). Since the decimal points are omitted, and both cents places are entered, the average ATM data entry task requires an expected number of 4.7 keystrokes. The predicted numeric entry error rate is given by:

$$(4.7) \times 0.033 = 0.155 \quad (\text{data entry task error rate}). \quad (3.4)$$

All other ATM keying activities can be analyzed in a similar manner, resulting in the task error rate predictions as shown in Table 3.3.

3.6 Stochastic Model

A system may be described which can at any time be in one of a set of mutually exclusive states, and undergoes changes of state according to a set of probabilistic rules. The set of random variables $X(t)$ which depend upon a parameter t (usually denoting time) is said to define a stochastic process. For each set of t 's there is a corresponding probability distribution of the associated variables. If the t 's are discrete, the corresponding random variables are denoted by (X_1, X_2, \dots) . In the simplest case a sequence of possible outcome states (events) E_1, E_2, \dots of an experiment are strictly independent.

3.6.1 Classification of States

It is possible to classify and characterize the states of an experiment according to the probability of returning to a state after t transitions (Hillier and Lieberman, 1986; Winston, 1987).

- * A state E_j is said to be recurrent if it is certain that the system will return to it.

- * A state to which a return is uncertain is said to be transient.

Table 3.3 Expected Keystrokes and Predicted Task Error Rates for ATM Keying Activities (Adapted from Rodgers et al., 1986).

Keying Activity	Task Locus	Expected Values	
		Number of Keystrokes	Task Error Probability
Enter PIN Number	KeyPad	4	0.132
Choose Transaction	FunctKey	1	0.033
Enter Account	FunctKey	1	0.033
Enter Amount	KeyPad	4.7	0.155
Another Transaction	FunctKey	1	0.033
Enter Account	FunctKey	1	0.033
Enter Amount	Keypad	4.7	0.155

- * A state from which a transition can result in the system never returning to that state is called null.
- * A state is periodic if a return is possible only in $k, 2k, \dots$ steps (where k is an integer greater than 1).
- * A state which is neither periodic nor null is called an ergodic state.

There is a weak dependence in which a probability is associated with each pair of events - the conditional probability of occurrence of event E_j , given that event E_i has occurred, or element $p_{ij} = P(E_j | E_i)$. In this weak dependent situation, the sequence of trials of an experiment results in outcomes E_1, E_2, \dots , and the "transition" probability (element p_{ij}) is the probability of outcome E_j , given that outcome E_i occurred in the previous trial.

If the probability of any series of outcomes can be determined from the absolute probabilities vector $a_j^{(n)}$ after n transitions and transition probabilities, such a system is described by a Markov chain. A Markov chain in which all states E_j can (eventually) be reached from any other state E_i is called irreducible. An irreducible Markov chain in which all states are ergodic is called an ergodic Markov chain.

If the probabilities of matrix P_{ij} are dependent on a continuous parameter such as time, the process which can be described by the Markov chain is called a Markov process. The key property of a Markov process is that the probability of

the state at any given moment is dependent only upon the immediately preceding state. Information from other previous states has no effect on the outcome of a new state. The system is then said to be memoryless.

3.6.2 Steady-state Probabilities

It is of particular interest to find the long-run behavior of stochastic systems. As the number of transitions increases, the absolute probabilities become independent of the initial conditions. After a very large number of transitions, the absolute probability distribution will approach a value reflecting the percentage of time the system resides in each state.

The limiting distribution, or steady state solution can be obtained by either analytical or numerical solution methods. The exact limiting distribution for an irreducible ergodic Markov chain can be found by means of the algebraic solution of a system of simultaneous equations as follows (Hillier and Lieberman, 1986):

Develop the set of equations:

$$\pi_j = \sum_{i=0}^M \pi_i P_{ij}, \quad (j = 0, 1, \dots, M) \quad (3.6)$$

$$1 = \sum_{j=0}^M \pi_j \quad (3.7)$$

where:

$$\lim_{n \rightarrow \infty} a_j^{(n)} = \pi_j \quad (j = 0, 1, \dots, M)$$

First, one redundant equation is eliminated from the first set of equations. The selection is made arbitrarily. After solving simultaneously, the solution yields the limit (as n approaches infinity) of $\pi_j^{(n)}$, which is the steady state solution vector π_j .

The reciprocal of each element in the steady state π vector is equal to the expected recurrence time, in number of transitions (on the average) that pass between re-visits to a given node (Hillier and Lieberman, 1986).

A valid numerical solution can also be found by repeatedly multiplying the one-step transition probability matrix by itself - in effect, raising the matrix to a high numbered power. For example, consider the one-step Markov transition matrix as shown in Table 3.4. After each successive multiplication, the similarity between the rows of the transition matrix becomes more apparent. Eventually, for example at an arbitrarily high value of $n = 256$ iterations, the row vectors comprising matrix $P_{ij}^{(n)}$ approach the point of being identical, coinciding with the steady state vector π_j found analytically. In the example problem, the repeated squaring results in the $P_{ij}^{(256)}$ matrix as shown in Table 3.5.

In practice, the numerical technique can be easily employed manually for small-scale problems, and by matrix multiplication computer software programs for larger scale problems. In practice, the algorithm is incorporated into a computer program and set up to automatically terminate processing when the steady state solution is found to a desired level of precision (See Appendix C).

Table 3.4 Sample One-Step Markov Transition Matrix (Adapted from Bhat, 1984)

		0	1	2	3	4
$P^{(1)}$	0	.13	.34	.35	.15	.03
	1	.02	.24	.42	.26	.06
	2	.00	.07	.38	.42	.13
	3	.00	.03	.15	.53	.29
	4	.00	.00	.05	.29	.66

Table 3.5 Markov Transition Matrix after 256th Multiplication (Adapted from Bhat, 1984)

		0	1	2	3	4
$P^{(256)}$	0	.001	.03	.152	.406	.41
	1	.001	.03	.152	.406	.41
	2	.001	.03	.152	.406	.41
	3	.001	.03	.152	.406	.41
	4	.001	.03	.152	.406	.41

The steps of the proposed algorithm are as follows:

1. Enter the transition matrix P_{ij} , tolerance T , and maximum number of iterations N .
2. Multiply the matrix P_{ij} by itself. Increment iteration counter n .
3. Compute the range R_j , the difference between the smallest and largest values in each column j .
4. If R_j is less than T for all j , the program terminates and displays: matrix $P_{ij}^{(k)}$, where $k = 2^n$; and approximate steady-state vector Π where π_j is the mean of the entries in each column of matrix $P_{ij}^{(k)}$.
5. If R_j is greater than T for any j , and iteration count $n < N$, go back to step 2 and continue.
6. If $n = N$, terminate the program and display a message that the iteration limit has been reached.

If the routine reaches the iteration limit and stops, the value of N can be increased and the program re-started. It is possible that even after a large number of iterations (say, in the instance of a 10×10 matrix, 256 iterations), the row vectors may still not converge. This could possibly be a result of too low a threshold, an instability due to excessive accumulation of rounding errors, or an error in model formulation. In this case the program terminates and displays an appropriate warning message.

3.6.3 Semi-Markov Process

When a stochastic system can reside in one or more of the states for a variable length of time, the problem can be more accurately defined as a semi-Markov chain. In order to adequately describe the situation, the time that the system spends in each of the system states during a given transition must be known. This value will be comprised of a mean (mean sojourn time) and variance (Bhat, 1984).

By redefining the problem as a semi-Markov chain, an exact steady-state solution can be found, but the procedure is more complicated. There are computer software packages, such as Markov1, available for personal computers, which can find numerical solutions for the steady-state vectors of Markov as well as semi-Markov chains (Grassmann, 1990). Semi-Markov analysis may be required in some instances. In problems where extreme variability in sojourn times exists between nodes, or when very accurate prediction of long-run state probabilities is needed, semi-Markov models may be formulated and solved using special techniques (Howard, 1971).

3.6.4 Goal Programming

Goal programming is a concept in which several incommensurable objectives are considered in order to reach the best combination of all goals (Charnes and Cooper, 1961). In the goal programming model, some goals may be

reached only at the expense of other goals. Since it may not be possible to optimize all goals, the individual goals are weighted and the higher ranked goals are given greater consideration (Lee, Moore and Taylor, 1985).

Goal programming models are formulated like linear programs, with the same type of limitations, assumptions and conditions, and can be solved by using a variation of the simplex method. Formulating a goal programming model as a linear program requires the introduction of two new deviational variables (d_i^+ and d_i^-) that reflect how much a given goal differs from (overutilizes or underutilizes) a goal objective. A numerical priority variable (P_i) is established for each goal in the problem based on the relative priority of achieving the goal. The objective function in a goal program is to minimize Z , the sum of each product of goal deviational variable and goal priority value (Lee, Moore and Taylor, 1985).

3.7 Ergonomic Design Factors

3.7.1 Design Population

Workstations which are used by an individual or a homogeneous group of people can be designed and optimized for the intended user base. Multiperson workstations for use by a heterogeneous population should be designed to include a certain portion of the population, rather than the mean of the entire population. For example, a control which is set to be within the reach of the 50th percentile reach limit will be out of reach of 50% of the population. Konz (1990) states this guideline as "Let the small woman reach; let the large man fit." Restating this principle, use the 5th percentile female as a lower limit, and the 95th percentile male as the upper limit in determining physical workstation design parameters.

In the ATM problem, fit is of less consequence than reach, therefore the design population will be defined as the 5th percentile females. In this case, 95 percent of females (and over 95 percent of males) will be able to reach all components in the designed workspace. The body dimensions for the design population are given in the diagram in Figure 3.1.

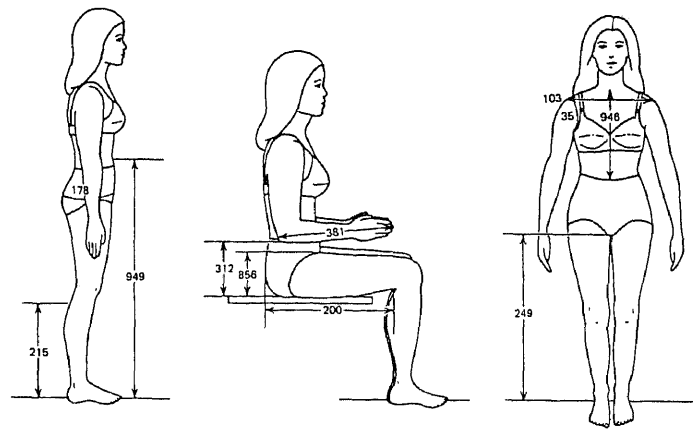
1985 Female^a

No.	Dimension	5%ile	Mean	95%ile
949	Waist height	93.1 (36.7)	100.7 (39.6)	108.1 (42.6)
249	Crotch height	67.7 (26.7)	74.4 (29.3)	81.3 (32.0)
215	Calf height	28.7 (11.3)	33.1 (13.0)	37.5 (14.8)
103	Biacromial breadth	33.4 (13.1)	36.1 (14.2)	38.8 (15.3)
946	Waist front	30.4 (12.0)	33.7 (13.3)	37.1 (14.6)
735	Scye circumference	34.1 (13.4)	37.8 (14.9)	41.9 (16.5)
178	Buttock circumference	86.0 (33.9)	95.1 (37.4)	106.6 (42.0)
312	Elbow rest height	19.2 (7.6)	22.9 (9.0)	27.1 (10.7)
856	Thigh clearance	10.4 (4.1)	12.5 (4.9)	14.9 (5.9)
381	Forearm-hand length ^b	39.7 (15.6)	42.8 (16.9)	45.9 (18.1)
200	Buttock-popliteal length	43.7 (17.2)	47.9 (18.9)	52.7 (20.7)

^a Data given in centimeters with inches in parentheses.

Figure 3.1 Selected Anthropometric Data for Design Population (Adapted from NASA, 1978; Kantowitz and Sorkin, 1983).

3.7.2 User Base Skill Level

It may be assumed that the population of users of ATMs will follow a specific distribution with regard to skill level. The factors in describing the user population include frequency of ATM use, age of user, education level, and income level.

ATM research, Taube (1988), reports that active ATM users belong to certain demographic classifications and that ATM usage can be classified into three categories: nonusers, who have no ATM usage; inactive users, who use their card two times a month or less; and active users, who use ATMs more than twice a month. A study of ATM usage patterns showed that only about 36% of the ATM card holders are active users, which confirms the industry accepted 33% value. A study at a large commercial bank in the western United States, which has over 1,300 ATMs showed that one-half to two-thirds of ATM users fall into the category of infrequent users, perhaps using ATMs only in an emergency (Haynes, 1990.)

The typical active users are characterized as males in the 18 to 34 age range with at least some college education, who are likely to use credit cards, and have above-average incomes. The probability of ATM usage as a function of several demographic factors is given in Table 3.6.

Table 3.6 ATM Usage by Selected Demographic Factors.

Demographic Factor		Non- User %	Inactive User %	Active User %
Sex	Male	47.16	21.98	30.88
	Female	65.66	21.42	13.92
Age	18 – 24	48.83	21.42	23.48
	25 – 34	47.23	27.54	25.23
	35 – 44	59.76	23.69	16.55
	45 – 54	67.34	20.27	12.39
	55 – 64	71.04	19.92	9.04
	65 & over	86.25	9.35	4.40
Education	Grade School	96.61	3.39	0.00
	High School	68.23	20.79	10.98
	Some College	57.44	23.59	18.97
	College Graduate	52.28	24.13	23.59
	College Graduate +	53.72	22.96	23.32
Annual Income	Under \$5,000	62.69	22.81	14.50
	5,000 – 9,999	41.78	16.71	41.51
	10,000 – 14,999	74.74	13.40	11.86
	15,000 – 24,999	63.66	25.16	11.18
	25,000 – 34,999	56.95	26.61	16.44
	35,000 – 44,999	54.33	25.67	20.00
	45,000 – 59,999	77.27	18.18	4.55
	60,000 and over	60.73	19.02	20.25

Notes:

1. Nonusers: No reported ATM Usage
2. Inactive Users: 2 Accesses or less per month.
3. Active Users: More than 2 accesses per month.
4. Low-Income Active Users are primarily college students who expect to be only temporarily in this income range.
5. Source: Taube (1988).

It is assumed here that the ATM user population is a subset drawn at random from the overall population, the breakdown of the ATM user population is determined by combining these results with vital statistical data on the general public. According to 1988 figures (U.S. Bureau of the Census, 1988), the median age of individuals is 32.3 years, and the median family income is \$30,853 per year for a total of 65,133,000 families. Additional data on the composition of the general U.S. population is as shown in Table 3.7.

Using the data on ATM usage probabilities and population demographic data, a Bayesian analysis is performed to determine an approximation of the distribution of the ATM user population by selected factors (Drake, 1967). For example, the probability that an active ATM user is female, $P(F|A)$, is estimated according to Equation 3.9.

$$P(F|A) = P(F) P(A|F) / [P(F) P(A|F) + P(M) P(A|M)] \quad (3.9)$$

The complete summary of the results of this analysis are given in Table 3.8, and shown graphically in Figures 3.2 and 3.3. From the results, it may be presumed that the ATM user base is somewhat reflective of the general population in terms of physical and experience characteristics, and that the design population should be defined accordingly.

Table 3.7 Selected U.S. Population Statistics (Based on 1980 Census Data).

Demographic Factor		Number (millions)	Percent of Total
Sex	Male	71.90	47.42
	Female	79.70	52.58
Age	18 - 24	26.70	14.66
	25 - 34	43.70	24.00
	35 - 44	35.30	19.38
	45 - 54	24.80	13.62
	55 - 64	21.20	11.64
	65 & over	30.40	16.69
Education	Grade School	36.80	23.70
	High School	61.80	38.90
	Some College	26.40	17.00
	College Graduate	27.90	18.00
	College Graduate +	3.60	2.30
Annual Income	Under \$5,000	2.88	4.42
	5,000 - 9,999	4.79	7.35
	10,000 - 14,999	5.87	9.02
	15,000 - 24,999	12.18	18.70
	25,000 - 34,999	11.39	17.49
	35,000 - 44,999	9.33	14.32
	45,000 - 59,999	8.82	13.54
	60,000 and over	9.88	15.17

Notes:

1. Education data reflects highest level achieved by adults (18 years and older).
2. Source: U.S. Bureau of the Census (1988).

Table 3.8 Bayesian Analysis of ATM User Population.

Demographic Factor		Xi	Observed Data				Computed		
			Prob (Xi)	Prob (N Xi)	Prob (I Xi)	Prob (A Xi)	Prob (Xi N)	Prob (Xi I)	Prob (Xi A)
Sex	Male	1	0.474	0.472	0.220	0.309	0.393	0.481	0.667
	Female	2	0.526	0.657	0.214	0.139	0.607	0.519	0.333
Age	18 – 24	3	0.147	0.488	0.277	0.235	0.116	0.185	0.213
	25 – 34	4	0.240	0.472	0.275	0.252	0.183	0.302	0.374
	35 – 44	5	0.194	0.598	0.237	0.166	0.187	0.210	0.198
	45 – 54	6	0.136	0.673	0.203	0.124	0.148	0.126	0.104
	55 – 64	7	0.116	0.710	0.199	0.090	0.134	0.106	0.065
	65 & over	8	0.167	0.863	0.094	0.044	0.232	0.071	0.045
Education	Grade School	9	0.237	0.966	0.034	0.000	0.328	0.045	0.000
	High School	10	0.389	0.682	0.208	0.110	0.380	0.455	0.348
	Some College	11	0.170	0.574	0.236	0.190	0.140	0.226	0.263
	College Grad	12	0.180	0.523	0.241	0.236	0.135	0.244	0.346
	College Grad+	13	0.023	0.537	0.230	0.233	0.018	0.030	0.044
Annual Income	Under \$5,000	14	0.044	0.627	0.228	0.145	0.045	0.046	0.039
	5,000 – 9,999	15	0.074	0.418	0.167	0.415	0.050	0.056	0.187
	10,000 – 14,999	16	0.090	0.747	0.134	0.119	0.109	0.055	0.066
	15,000 – 24,999	17	0.187	0.637	0.252	0.112	0.192	0.216	0.128
	25,000 – 34,999	18	0.175	0.570	0.266	0.164	0.161	0.213	0.177
	35,000 – 44,999	19	0.143	0.543	0.257	0.200	0.126	0.168	0.176
	45,000 – 59,999	20	0.135	0.773	0.182	0.046	0.169	0.113	0.038
60,000 and over	21	0.152	0.607	0.190	0.203	0.149	0.132	0.189	

Notes:

1. N = Nonusers: No recorded ATM Usage
2. I = Inactive Users: 2 Accesses or less per month.
3. A = Active Users: More than 2 accesses per month
4. Observed Data for Prob(Xi) from U. S. Bureau of the Census (1988)
5. Observed Data for Prob(N|Xi), (I|Xi), (A|Xi) from Taube (1988)

Age

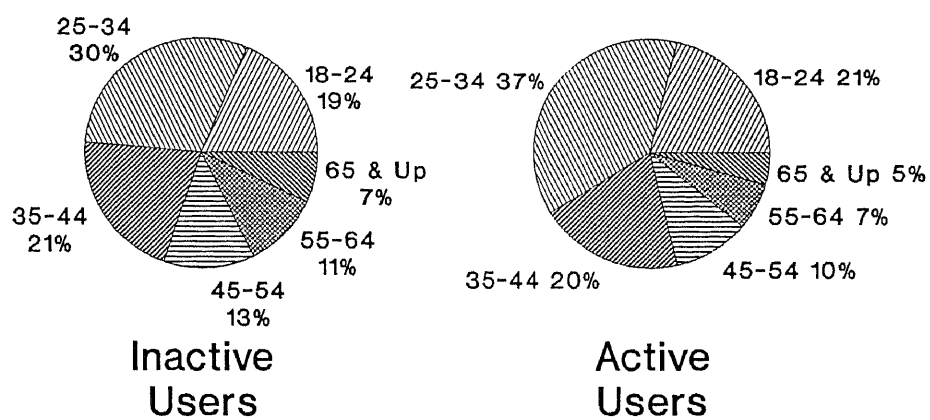

Sex

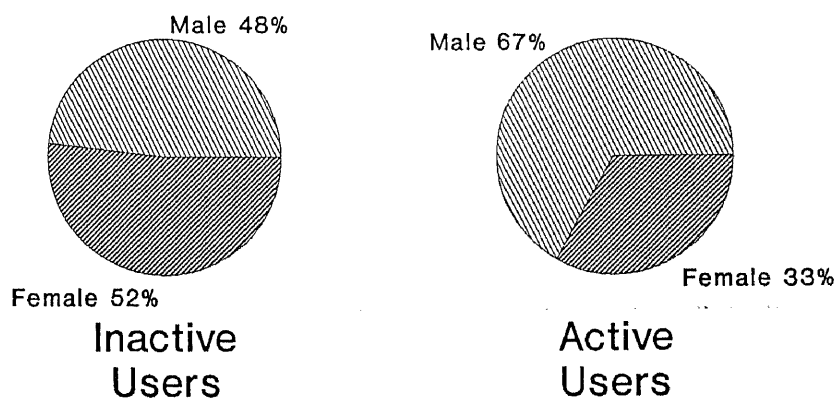
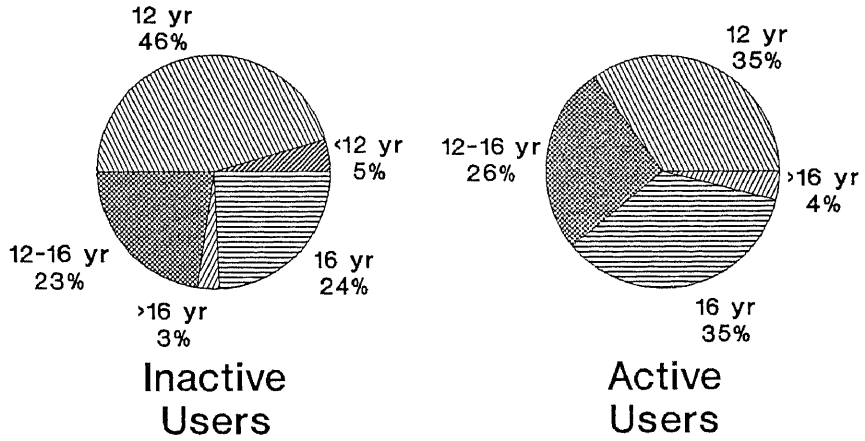

Figure 3.2 ATM User Population by Age and Sex.

Education (years)



Annual Income (\$1000's)

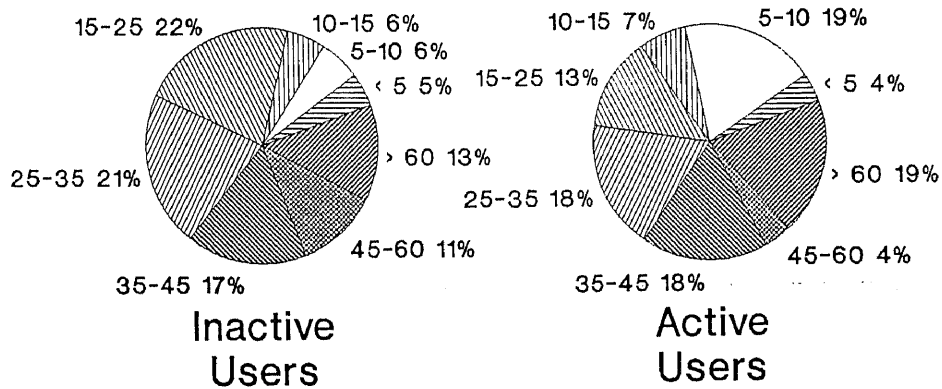

Figure 3.3 ATM User Population by Education and Income.

3.7.3 Defining the Control Panel

The set S_i is defined as the set of locations on the control panel whose characteristics (size, proximity to operator, etc.) are compatible with the requirements of control or display i . With a continuous solution space, the control panel layout problem is too complex to solve, as $S_i = \text{infinity}$, with an infinite number of feasible locations included in the control panel analysis.

We can, fortunately, simplify the problem, since for ergonomic reasons the control spacings and sizes must be relatively large. Literature in the area of human factors recommends physical parameters for buttons and keypads for various modes of operation. Since the ATM user population is comprised of members of the general public, we will assume that strong keyboarding skills will not normally be present. Therefore, the most likely technique of use is believed to be a one finger random operation. In this application, it is suggested that the push-button diameter should be a minimum of 0.5 in.; and that spacing between push-buttons should be at least 0.5 in., with 2.0 inches spacing preferred (Moore, 1975). In the case of keyboards and keypads, the key centers should ideally be 19 millimeters (0.75 in.) apart. The key tops should be 12 mm (0.5 in.) square (Alden et al., 1972). The controls should be spaced no closer than the recommended 2.0 in. and be at least 0.5 inches in diameter. A keypad of 12 such keys arranged in 4 rows and 3 columns can be made to fit into a control panel space of 8.125 sq. in. The adherence to this guideline will significantly reduce the complexity of the layout problem.

A special case of the layout problem defines the set of all locations as points on a rectangular lattice. In the ATM problem, by restricting the feasible object locations (S_i) to the intersections of a 3.0 x 3.0 inch planar grid, the problem can be discretized and made in some sense finite. Given a finite number of feasible locations, the problem can be modeled as a discrete optimization problem once suitable cost coefficients are developed.

Another assumption used in the model is that space is allocated in increments of 9 sq. in. for each of the control panel elements. Thus, by eliminating the effect of irregular areas and the possibility of overlapping of adjacent controls, the problem is greatly simplified. This assumption can be justified by observing that nearly all ATM control panel elements in the field fit inside the 9 sq. in. envelope.

3.7.4 Accessibility of Controls

Although the goodness of a particular control location can be highly subjective in nature, there has been at least one attempt to quantitatively measure the accessibility of controls for human operators. Banks and Boone (1981) introduced the concept of an "Accessibility Index" as a method for quantifying control accessibility. The index takes into consideration the reach envelope of the operator, the frequency of use of the particular control, and the control position with respect to the operator. The accessibility index (I) is computed according to Equation 3.8:

$$I = r - \frac{\sum_s \left[\frac{\sum_n F}{N} \right]}{s} \quad (3.8)$$

Where:

- r = the correlation coefficient between the distance from the operator and the ranked frequency of use of the control.
- n = the number of controls outside of the reach envelope.
- N = the total number of controls.
- s = the number of operators under study.
- F = the rank of each control outside the reach envelope.
- f = the rank of each control within the reach envelope.

The accessibility indices for various control panel configurations can be computed and the results compared. Or, the problem could be formulated to find the configuration which yields the optimal value of I , when the control locations are allowed to vary.

3.8 Finding the Optimal Layout

Generally, the workspace, and consequently the set of feasible control button locations, will be given as part of the problem definition. Once a feasible work area is defined, an attempt is usually made to determine the set of control locations which provide a lowest-cost solution. A linear programming problem can be formulated in which the optimal solution minimizes the sum of all the costs

of assigning each required control to a feasible location, while not violating any constraints.

3.8.1 Complexity of the Layout Problem

When assigning m facilities to a finite number of locations n , the number of possible layouts is finite. Enumerating each of the feasible arrangements is possible but computationally practical for only the smallest problems, since the number of layouts is $n!$. A formulation of the problem as a special case of the quadratic assignment problem, using a branch and bound solution is given by Lawler (1963). Although more efficient than total enumeration, the algorithm is probably not computationally feasible for n much larger than 15 (Gilmore, 1962). Other algorithms are available to find the exact assignment solution with orders of complexity of n^3 (Lawler, 1976) and $n^2 \log n$ (Karp, 1980). Finding exact solutions to larger scale problems by these methods may still be cost-prohibitive for $n > 15$ (West, 1983).

CRAFT (Computerized Relative Allocation of Facilities Technique) is a heuristic deterministic improvement technique (Nugent, et al., 1967). The algorithm improves upon a given solution by evaluating the effect on the cost function of all possible two-department exchanges, and choosing the exchange yielding the greatest improvement. The algorithm continues until no further improving exchanges are possible. In the worst case, the number of exchanges to evaluate is $n(n - 1)/2$.

3.8.2 Types of Assignment Costs

The individual assignment cost coefficients in general layout problems can be divided into two basic types. First, the motion costs generally reflect the cost of motion in terms of distance or time costs in moving between feasible locations. For example, the costs of transporting goods between feasible warehouse locations are motion costs. Second, the position costs - independent of motion - represent the costs incurred by an object or component simply being in a given location. For example, the costs of renting space in various feasible cities are position costs, since they are incurred even with no motion. Position costs for a human operator are biomechanical in nature and can be derived by employing a combination of anthropometric, biomechanical, and kinematic analyses.

3.8.2.1 Motion Costs

The typical problem in the assignment of facilities to locations is to place the facilities in a functional layout so as to minimize the total material handling cost or flow among the facilities. As formulated, the problem is to assign n equally-sized facilities to n homogeneous fixed locations within a prescribed area so as to minimize the cost function:

$$Z = \sum_{i=1}^n \sum_{j=i+1}^n f_{ij} d_{kr} \quad (3.9)$$

where:

f_{ij} = the flow of material between the i th and the j th facility ($= 0$ for $i = j$),

d_{kr} = the distance between the k th location and r th location ($= 0$ for $k = r$).

In many instances coefficients for the cost of motion are derived from a linear function of distance from any location in a control panel to any other control location. In this case motion costs can readily be obtained from the feasible workspace. Given the separation distance (D) between controls, and the diameter (d) of the control, the rectilinear spacing (s) between actuation points (control centers) is simply: $s = D + d$. If each location (a and b) is defined as a set of Cartesian coordinates (X_a, Y_a) and (X_b, Y_b) such as $a = (1,3)$ and $b = (4,7)$, the shortest direct (straight-line) distance between them is given by:

$$D = [[s(X_b - X_a)]^2 + [s(Y_b - Y_a)]^2]^{0.5} \quad (3.10)$$

If the values for D and d are taken from the ergonomically recommended guidelines (Moore, 1975), namely $D_{\min} = 2.0$ inches, and $d_{\min} = 1.0$ inches, then the value for spacing will be $s = 3.0$ inches. The distances between each point and each other point in the control panel are computed from Equation 3.10 as shown in Table 3.9.

For example, with a control panel with 12 feasible locations, arranged in three rows of four columns, with 3.0 x 3.0 inch spacing, the distance matrix is given in Table 3.10.

Table 3.9 Motion Costs for Equally-Spaced Controls on a Control Panel of N Feasible Locations.

From	To					
	1	2	...	n	...	N
1	0.00	3.00	...	D(1,n)	...	D(1,N)
2	3.00	0.00	...	D(2,n)	...	D(2,N)
n	D(n,1)	0.00	...	D(n,N)
N	D(N,1)	D(N,n)	...	0.00

Notes:

1. All motion is bidirectionally equivalent.
2. Motion costs are directly proportional to straight-line distances between points (X_a, Y_a) and (X_b, Y_b) .
3. All N feasible locations are on a planar grid.
4. Grid spacing $(s \times s)$ is 3.00 x 3.00 inches.
5. $D(a,b) = [[s(X_b - X_a)]^2 + [s(Y_b - Y_a)]^2]^{0.5}$

Table 3.10 Distance Cost Matrix for 3.0-inch Equally-Spaced Controls on a 12-Control Panel.

Location		To	1	2	3	4	5	6	7	8	9	10	11	12
From	r	r	1	1	1	1	2	2	2	2	3	3	3	3
	c	c	1	2	3	4	1	2	3	4	1	2	3	4
1	1 1	1 1	0.0	3.0	6.0	9.0	3.0	4.2	6.7	9.5	6.0	6.7	8.5	10.8
2	1 2	1 2	3.0	0.0	3.0	6.0	4.2	3.0	4.2	6.7	6.7	6.0	6.7	8.5
3	1 3	1 3	6.0	3.0	0.0	3.0	6.7	4.2	3.0	4.2	8.5	6.7	6.0	6.7
4	1 4	1 4	9.0	6.0	3.0	0.0	9.5	6.7	4.2	3.0	10.8	8.5	6.7	6.0
5	2 1	2 1	3.0	4.2	6.7	9.5	0.0	3.0	6.0	9.0	3.0	4.2	6.7	9.5
6	2 2	2 2	4.2	3.0	4.2	6.7	3.0	0.0	3.0	6.0	4.2	3.0	4.2	6.7
7	2 3	2 3	6.7	4.2	3.0	4.2	6.0	3.0	0.0	3.0	6.7	4.2	3.0	4.2
8	2 4	2 4	9.5	6.7	4.2	3.0	9.0	6.0	3.0	0.0	9.5	6.7	4.2	3.0
9	3 1	3 1	6.0	6.7	8.5	10.8	3.0	4.2	6.7	9.5	0.0	3.0	6.0	9.0
10	3 2	3 2	6.7	6.0	6.7	8.5	4.2	3.0	4.2	6.7	3.0	0.0	3.0	6.0
11	3 3	3 3	8.5	6.7	6.0	6.7	6.7	4.2	3.0	4.2	6.0	3.0	0.0	3.0
12	3 4	3 4	10.8	8.5	6.7	6.0	9.5	6.7	4.2	3.0	9.0	6.0	3.0	0.0

Notes:

1. All motion is bidirectionally equivalent
2. Motion costs are straight-line distances (in inches)
3. All 12 locations are on a 3 row x 4 column planar grid
4. Grid spacing (s x s) is 3.00 x 3.00 inches

3.8.2.2 Position Costs

An alternate cost factor to be considered is the position cost - a static function independent of motion or materials flows - of a facility i being assigned to a particular location j . This cost, (c_{ij}) analogous to the fixed cost incurred in renting the space required for a facility, may in many problems be more significant than motion cost. It is possible that, for small-scale layouts such as the control panel problem, the motions may be of such short distance that motion costs may be ignored. In this instance, the cost of placing the human body in a given position may be of great consequence.

For example, a group of controls which must be frequently operated can be placed in close proximity to each other and achieve minimal cost from the motion point of view. However, unless the position cost is minimized, the arrangement can be very costly in terms of the stress inflicted on the body in reaching to each control's position. Consider the three arrangements of controls in Figure 3.4. Assume that the operator's task requires that switches A, B, C, and D are operated in succession, and that joystick E is used to control an industrial process for a ten minute period. In each case, the motion costs for performing the given set of tasks are identical. However, the position costs will vary because the operators will use different sets of body configurations and will as a result experience different levels of biomechanical stress. It is apparent in this example that, in terms of overall cost, arrangements (a) and (b) are both inferior to arrangement (c). Assessment of the goodness of these arrangements may be made by determining quantitatively the biomechanical stress imposed by each alternative.

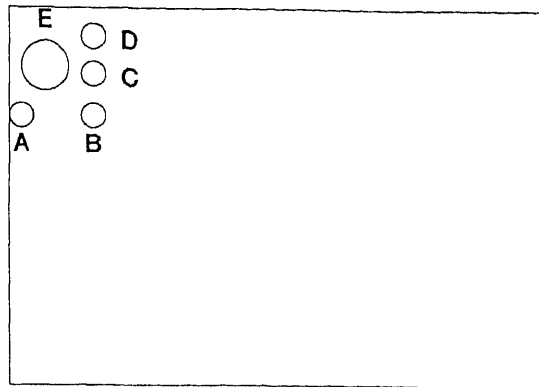

- (a) Poor - Centroid of controls at extreme upper left position in user's reach envelope. Position costs are excessive.

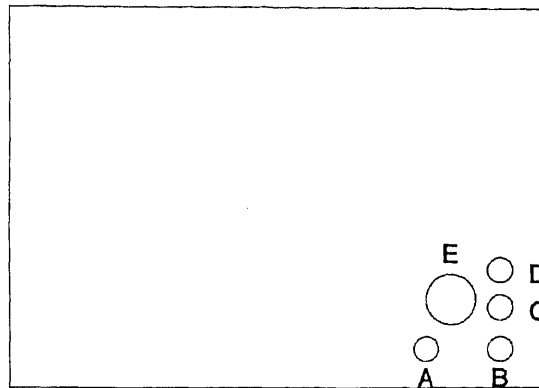

- (b) Poor - Centroid of controls at extreme lower right position in user's reach envelope. Position costs are excessive.

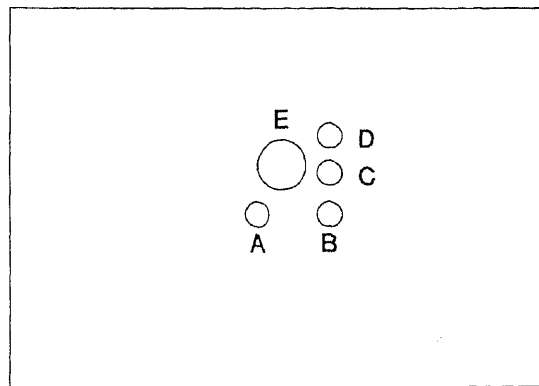

- (c) Good - Centroid of controls is at optimal position within user's reach envelope. Position costs are minimized.

Figure 3.4 Three Control Arrangements with Identical Motion Costs.

3.8.3 Biomechanical Analysis

From reports on the anthropometric studies (NASA, 1978), it has been determined that, within the range of motion, the force available in a body element has a definite relationship to that element's joint angle (α). Experimental studies of elbow angle versus force resulted in the data given in Figure 3.5.

Shown graphically, the results indicate that the maximum available force is present at approximately 90 degrees of elbow angle. At this point (α^*), it is evident that the joint is at an optimal configuration for performing work.

3.8.3.1 Human Work Endurance

Much work has been done in the field of human work endurance. Among those studies in the area of fatigue and work endurance, it has been repeatedly shown that the endurance time (T_e) is related to the degree of stress encountered by the joint, muscle or body member, expressed as a percentage of the maximum total capacity of that member (Simonson and Lind, 1971; Morton, 1987).

Experimental evidence of the relation between muscle fatigue, consequently endurance, and the level of imposed workload was provided by Rohmert (1960), and confirmed by Simonson & Lind (1971) and Hayward (1975). It was found that, for example, at a required force exertion level (R) of $R = 25\%$ of maximum voluntary strength, usually measured as the muscle's maximum voluntary contraction (MVC), the subject had an endurance time T_e of about

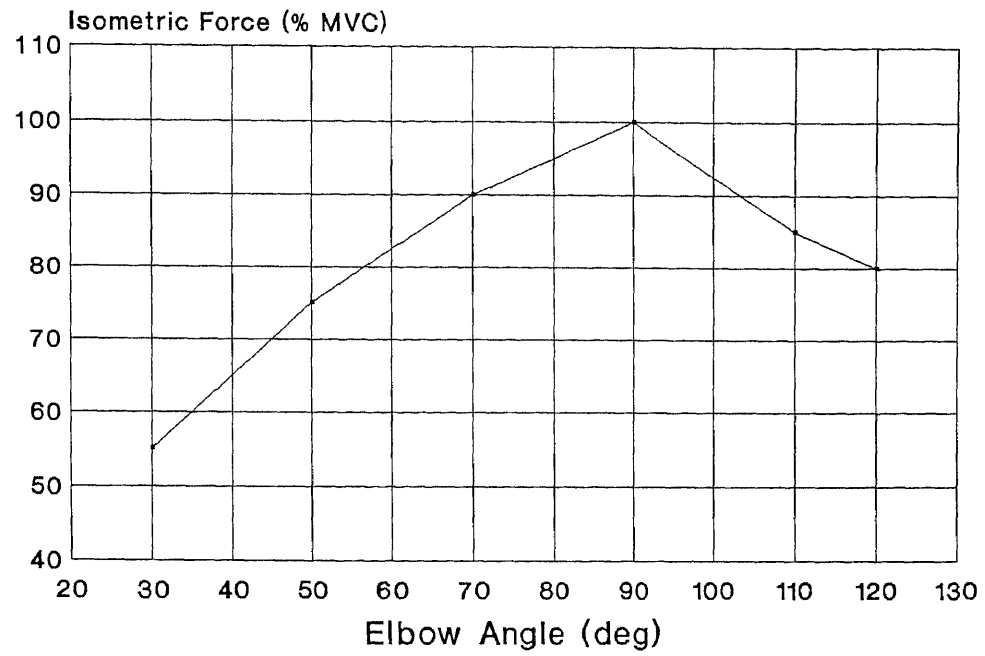

Figure 3.5 Force Available at Various Elbow Configurations (Adapted from Rodgers et al., 1986).

four minutes, while at $R = 50\%$ of maximum voluntary strength, the T_e value reduces to only 1 minute.

Theoretically, as the exerted force approaches the total available force, the performance, measured in terms of endurance time rapidly degrades and T_e approaches zero. The level of muscular contraction at which fatigue becomes a prohibiting factor in performing a required function is called the "threshold of fatigue," and is given the symbol P_1 , expressed as a percentage of the maximum voluntary contraction of the muscle (Bigland, Ritchie & Woods, 1984). As the force demands are reduced, as P_1 approaches zero, the fatigue factor tends to vanish and endurance time goes to infinity. Morton (1987) developed a model to link fatigue and endurance in static work and found that $P_1 < 0.1$ yielded a good fit to the experimental data already obtained.

3.8.3.2 Biomechanical Joint Analysis

For a human operator, each joint involved in the control operation will have, accordingly, a relationship between the available force and the joint angle. In the static case, the optimal joint angle is defined as that angle for which the available force is at a maximum. This information can be either presented as data to a computer program, or expressed graphically for use later.

Since more than one joint is involved in reaching a control location, each point in space may have multiple (feasible and infeasible) solutions with respect to joint angles. It is therefore necessary to apply techniques to obtain local optimal

solutions. The assumption is made that the global optimum will correspond to the set of local optimal solutions. (Nedungadi & Kazerouinian, 1989). Therefore, if each joint involved in reaching a point in space is set to its optimal condition, and there is independence between each joint, then the total configuration should be optimal.

3.8.4 Arm Kinematic Analysis

Similar to the human arm in many respects is the robot manipulator arm. The end-effector is the most extreme member at the end of the chain of connected joints, and is analogous to the human finger or hand. In the field of robotics, the study of arm kinematics deals with the geometry of robot arm motion with respect to a fixed-reference coordinate system. The kinematics problem can be divided into two subproblems - forward kinematics and inverse kinematics problems.

3.8.4.1 Forward Kinematics

The forward (or direct) kinematics problem is solved in order to determine the position and orientation of a robot's manipulator with respect to a standard reference coordinate system. The positions are derived from the angular orientations of the set of joints comprising the whole configuration and the lengths of the links involved. By direct kinematic analysis, any end-effector position can be predicted from the given set of joint angles and link lengths. The

development of the formulas for computing the forward kinematics arm solution is detailed in the Appendix.

By applying forward kinematics on the vector of optimal joint angles, we can find an optimal end-effector position. By perturbing the joint angle vectors to the limits of their optimal conditions, and re-solving, a space or envelope of control locations can be developed which will theoretically provide a maximum endurance time (T_e^*). The control envelope in the ideal case will have an $T_e^* =$ infinity, in which case any control within the T_e^* space can presumably be operated for a long duration without serious detrimental effects from the viewpoint of fatigue. In the practical case, however, the T_e^* space will have the longest finite endurance time during which work may be performed. It is therefore desirable to assign only those controls with the longest duration requirements to the T_e^* space.

3.8.4.2 Inverse Kinematics

It is useful to be able to determine the set of joint angles needed to reach a given coordinate in space. By solving the inverse kinematic problem, a set of feasible joint angles is found. Various techniques of solution are available. The formulas used in the actual method of solution are described in detail in the Appendix.

3.9 Determining Optimal Control Location

Given the set of joint angles, each proposed control location can be evaluated in terms of endurance time degradation. To accomplish this, information including force requirements, control positions, and the configuration of the joint in question are analyzed to determine an estimate of the predicted endurance time for each joint.

When this procedure is repeated for each joint involved in the activity, the results can be combined to arrive at a total penalty cost. For each feasible point in the control area, a total penalty value can be determined. The objective is to minimize the total endurance penalty cost for the entire activity. After analysis, the results can be given in a tabular form, shown graphically, or provided as input data to optimization programs.

3.10 Determining Endurance Time Penalty

Biomechanical penalty costs are developed based on reduced endurance times or increased discomfort levels due to the suboptimal joint configuration needed to reach the control location in question. For control locations outside of the T_e^* layout, some quantitative estimate of the penalty cost is needed. One approach for developing appropriate cost coefficients is to express the endurance time (T_e) as a function of the position in space of the end-effector.

If the end-effector position is known, as is the case with a fixed control panel, the joint angles required to reach that position can also be determined. This can be accomplished by applying techniques of inverse kinematics. The problem in inverse kinematics is to calculate the joint angle vector given the position and orientation of the end-effector. Solving the problem in inverse kinematics will yield a number of solutions which are used to determine a feasible set of joint angles needed to reach a given point in space. Each feasible control location in the workspace can be analyzed and a corresponding joint angle vector, or solution set, developed.

In conjunction with the biomechanical principles, each of the joint angle vectors is compared with the data derived from biomechanics research. For each element of the joint angle vectors (ϕ , θ , δ), an estimate of the endurance time (T) is made. The theoretical endurance time (T_e) for the entire joint angle vector, hence the control location, is the minimum of the set of individual element endurance times according to:

$$T_e = \text{MIN}_j \{T_j\}, \quad \text{where } j = 1, 2, 3 \quad (3.11)$$

Another approach is to determine the optimal joint configuration by studying each individual joint and optimizing it independently. From the solution set(s), a primary configuration is selected. The rationale for the selection may be to optimize the largest joints first, enumerate and (by exhaustive search) evaluate all combinations of feasible solutions. Alternately, techniques such as shortest route, or dynamic programming may be employed to find the optimal combinations more directly.

3.11 Optimization Methods

The endurance time reductions, or relative penalty costs, can be used as cost coefficients in appropriate optimization algorithms. Once a primary (presumably feasible) configuration has been selected, the values of all joint angles (α_i) are compared with the previously found optimal joint angles (α_i^*). The deviation (β_i) is the absolute value of the difference between actual and optimal.

The cost of choosing a sub-optimal α_i is given by the penalty function $P_i = f(\beta_i, F)$. The penalty is a function of the force applied and the deviation from optimality. This function will possibly vary from joint to joint, and probably be non-linear in nature. The function may be developed on a case-by-case basis for use as the need arises.

To compute the total penalty cost for control location i , the program algorithm will use: control i 's Cartesian spatial coordinates (x_i, y_i, z_i); primary configuration ($\alpha_s, \alpha_e, \alpha_w$); deviation from optimal ($\beta_s, \beta_e, \beta_w$); and penalty cost (P_s, P_e, P_w). The total cost (C_i) is the result of the addition of the individual penalty costs from the individual joints comprising the configuration. Although this approach would probably yield good solutions by classical non-linear optimization techniques, the problem can be modeled as a linear assignment problem and solution found using simpler methods.

3.11.1 Linear Programming Solution

One of the simplest types of mathematical models in operations research is the linear programming (LP) model. The mathematical formulation of an LP problem consists of three parts. First, a set of decision variables which reflects the value of each unknown input component of the solution. Second, a set of constraints limiting the values of the decision variables based on some externally imposed restriction. Third, an objective function, with decision variables and a corresponding set of cost (or benefit) coefficients reflecting the loss or gain associated with employing a given unit of decision variable in the final solution.

The solution of LP models can be achieved analytically by use of the simplex algorithm. However, since a linear program with N constraints will have on the average $2N$ iterations, a 5 constraint problem may require a time-consuming 10 iterations (Lee, Moore and Taylor, 1985). Therefore computer implementation of the simplex or dual-simplex algorithm is needed for all but the most simple LP problems. Small scale problems (up to 50 constraints and 100 variables) can be solved relatively quickly using the simplex computer program listed in the Appendix (Taha, 1986). The program can also be modified to increase this limit by changing the DIMENSION statement in the first line, however the program is not efficient to use above 200 variables. Problems of a larger scale (200 to 1500 constraints and/or variables) can be better solved using commercially available software packages. Programs such as LINDO (Lindo Systems Inc.), LP88 (Eastern Software Products), XPRESS-MP (MathPro Inc.), and others are available for a variety of popular computer hardware configurations including the Macintosh, IBM PC, AT, and 386 (Swain, 1990).

3.11.2 Linear Assignment Model

The classic linear assignment problem is a special case of the linear programming transportation model in which a number of facilities (workers, jobs, departments, etc.) are assigned to several destinations (machines, workspaces, etc.). The objective is to assign the jobs to the machines to achieve the lowest total cost, while not violating any constraints. For example, only one job can be performed per machine and only one machine is allowed per job.

The assignment problem is expressed mathematically as follows: A given job i , ($i = 1, 2, \dots, m$) can be assigned to a machine j , ($j = 1, 2, \dots, n$) at an assignment cost c_{ij} . If there are more machines than jobs ($m < n$), or more jobs than machines ($m > n$), it is necessary to balance the problem by adding either fictitious jobs or fictitious machines. Let x_{ij} represent the event of assigning job i to machine j . If $x_{ij} = 1$, then the j th job is assigned to the i th machine; while if $x_{ij} = 0$, then the j th job is not assigned to the i th machine. The objective function is thus:

$$\text{Minimize } Z = \sum_{i=1}^n \sum_{j=1}^n c_{ij} x_{ij} \quad (3.12)$$

subject to:

$$\sum_{j=1}^n x_{ij} = 1, \quad (j = 1, 2, \dots, n) \quad (3.13)$$

$$\sum_{i=1}^n x_{ij} = 1, \quad (i = 1, 2, \dots, n) \quad (3.14)$$

$$\text{and } x_{ij} = \{ 0, 1 \} \quad (3.15)$$

While this problem can be solved by standard linear programming methods, the simple structure and special nature of the assignment problem lends itself to an special method of solution. A solution algorithm called the Hungarian method (after the Hungarian mathematician Dr. Konig) has advantages in computational efficiency over standard linear programming and transportation methods. (Saaty, 1959; Lee, Moore, and Taylor, 1985).

3.11.3. Linear Assignment Solution

The first step in the algorithm is to develop a table of opportunity costs, reflecting the costs in choosing one course of action over another. It can be shown that the addition or subtraction of a constant to any row or column in the cost matrix c_{ij} does not affect the optimal solution of the assignment model. Consequently, the elements of each row (or column) in the matrix can be reduced by the smallest element in that row (or column) without changing the solution. In a simple example (Taha, 1987), the assignment costs have been determined and are as given in the cost matrix below.

$$C_{ij} = \begin{array}{ccc} & 5 & 7 & 9 \\ & 14 & 10 & 12 \\ & 15 & 13 & 16 \end{array} \quad (3.16)$$

Each row is reduced by the minimum of each entry in the row (p_j) giving a new cost matrix C'_{ij} .

$$C'_{ij} = \begin{array}{ccc|c} 0 & 2 & 4 & p_1 = 5 \\ 4 & 0 & 2 & p_2 = 10 \\ 2 & 0 & 3 & p_3 = 13 \end{array} \quad (3.17)$$

Each column is then reduced by the minimum of each entry in the column (q_i) giving a new cost matrix C''_{ij} .

$$C''_{ij} = \begin{array}{ccc|c} 0 & 2 & 2 & \\ 4 & 0 & 0 & \\ 2 & 0 & 1 & \\ q_1=0 & q_2=0 & q_3=2 & \end{array} \quad (3.18)$$

In this simple case, n zero elements can be found which satisfy both a row and column as shown in C_{ij}^* . The marked entries indicate the feasible and optimal assignments which can be made, so that if $c_{ij}^* = 0$ and marked, then decision variable $x_{ij} = 1$. The optimal assignment ($x_{11}=1, x_{23}=1, x_{32}=1$) has a total cost of $(5 + 12 + 13) = 30$, which is equivalent to $p_1 + p_2 + p_3 + q_3$.

$$C_{ij}^* = \begin{array}{ccc|c} 0 & 2 & 2 & \\ 4 & 0 & 0 & \\ 2 & 0 & 1 & \end{array} \quad (3.19)$$

In slightly more complex problems, the solution may not be obtained immediately. Further steps and iterations may be required, and additional rules are introduced into the algorithm. In the example below (Taha, 1987), the cost matrix is given as:

$$C_{ij} = \begin{array}{cccc} 1 & 4 & 6 & 3 \\ 9 & 7 & 10 & 9 \\ 4 & 5 & 11 & 7 \\ 8 & 7 & 8 & 5 \end{array} \quad (3.20)$$

The reduction of each row by p_i and column by q_j gives cost matrix C''_{ij} :

$$C''_{ij} = \begin{array}{cccccc} 0 & 3 & 2 & 2 & p_1=1 \\ 2 & 0 & 0 & 2 & p_2=7 \\ 0 & 1 & 4 & 3 & p_3=4 \\ 3 & 2 & 0 & 0 & p_4=5 \\ q_1=0 & q_2=0 & q_3=3 & q_4=0 \end{array} \quad (3.21)$$

Since a feasible assignment of zero elements cannot be made at this point, the minimum number of horizontal and vertical lines is drawn through rows and columns so that all zeros are crossed out. The application of this rule is shown below:

$$C''_{ij} = \begin{array}{cccc} 0 & 3 & 2 & 2 \\ 2 & 0 & 0 & 2 \\ 0 & 1 & 4 & 3 \\ 3 & 2 & 0 & 0 \end{array} \quad (3.22)$$

The next step is to subtract the smallest uncrossed element in $C_{ij}'' (= 1$ in this example) from each uncrossed element and added to each element at the intersection of two lines. The resulting cost matrix C_{ij}^* with optimal assignments as marked is shown below.

$$C_{ij}^* = \begin{array}{cccc} 0 & 2 & 1 & 1 \\ 3 & 0 & 0 & 2 \\ 0 & 0 & 3 & 2 \\ 4 & 2 & 0 & 0 \end{array} \quad (3.23)$$

The optimal assignment ($x_{11} = 1$, $x_{23} = 1$, $x_{32} = 1$, and $x_{44} = 1$) has a total cost of $(1 + 10 + 5 + 5) = 21$.

In this simple example, the optimal solution is found in only one iteration. However, it is not always possible to arrive at a solution this quickly. In the event that the optimal solutions are not obtained, the line drawing portion of the procedure is again repeated until a feasible and optimal assignment is reached.

In some cases, analysis of the final tableau yields more than one optimal set of assignments. If multiple optimal solutions are found, the choice of which solution set to use is arbitrary and can be based on heuristics or other factors.

Assignment problems of a larger scale are most efficiently solved on a computer in one of two ways. The problem can be modeled as a standard linear transportation program and solved with general purpose LP software, such as

LINDO; or preferably, a more efficient program can be used which deals with the special nature of the assignment problem, such as ASGN (Erikson and Hall). The ASGN computer solution of the above problem is accomplished in less than 1 second, as shown in the printout in Figure 3.6.

COMPUTER MODELS FOR MANAGEMENT SCIENCE
ASSIGNMENT MODEL

START TIME: 08-06-1991 - 19:07:48

--*-- INFORMATION ENTERED --*--

TOTAL NUMBER OF ROWS : 4
TOTAL NUMBER OF COLUMNS : 4
PROBLEM TYPE : MINIMIZATION

PAYOFF VALUES

	C1	C2	C3	C4
R1	1.000	4.000	6.000	
3.000 R2	9.000	7.000	10.000	
9.000 R3	4.000	5.000	11.000	
7.000 R4	8.000	7.000	8.000	
5.000				

--*-- RESULTS --*--

ROW ASSIGNMENTS

	C1	C2	C3	C4
R1	A	-	-	-
R2	-	-	A	-
R3	-	A	-	-
R4	-	-	-	A

TOTAL PAYOFF : 21

END TIME: 08-06-1991 - 19:07:49

----- E N D O F A N A L Y S I S -----

Figure 3.6 Computer Solution of Assignment Problem by ASGN.

CHAPTER 4 METHODOLOGY

The proposed methodology for ATM control panel design is comprised of several steps as outlined below.

1. Problem definition - Functional specifications for the problem include operational analysis, activity sequences, and determination of user population.

2. Preliminary panel definition. - Based on operational requirements, anthropometry of user population, and other ergonomic guidelines; a selection is made of the overall workstation size and shape, specific types of controls, and a basic set of feasible control sites.

3. Determination of position cost - Given a set of tasks, probabilities for various transactions, and their associated controls, the system is modeled as a stochastic process and the limiting behavior is found. From kinematics and biomechanics, a position cost in terms of fatigue rate is developed.

4. Model formulation - Develop a linear assignment problem to find the optimal arrangement which minimizes the sum of position costs in performing the specific set of activity sequences.

5. Solution - Find the optimal solution(s) and make a final selection based on heuristic guidelines for the design of hardware and software human-machine interfaces.

4.1 Operational Analysis

A typical ATM session consists of one or more of the following activities, which will be abbreviated as follows:

1. Withdrawal from Checking Account (CW)
2. Deposit to Checking (CD)
3. Withdrawal from Savings Account (SW)
4. Deposit to Savings Account (SD)
5. Withdrawal from Bank Credit Card (BW)
6. Transfer Between Accounts (TR)
7. Balance Inquiry (IN)

For each of these ATM activities, the selection and sequencing of activity elements (i.e., tasks and objects) are determined by the operational requirement specifications. From the set of requirement specifications, two lists, as shown in Tables 4.1 and 4.2, are created (Phillips, 1987).

1. Input/Output Objects List: the set of all physical OBJECTS (loci) needed for the activity.
2. Activity Elements List: the TASKS (verbs) and their associated OBJECTS (nouns) manipulated or used in performing a given Activity.

Table 4.1 Input/Output Objects List for Typical ATM.

Object ID	Name (Locus)	Noun
A	ATM Card Slot	CARDSLOT
B	Numeric Keypad	KEYPAD
C	Function Keys	FUNCTKEY
D	Deposit Slot	DEPOSSLOT
E	Receipt Dispenser	RECPTSLOT
F	Cash Dispenser	CASHSLOT

Table 4.2 Activity Elements List for Typical ATM.

No.	Activity Element	Verb	Noun
1	Insert ATM Card	INSERT	CARDSLOT
2	Enter PIN number	ENTER	KEYPAD
3	Choose Transaction	PRESS	FUNCTKEY
4	Enter Account	PRESS	FUNCTKEY
5	Enter Amount	ENTER	KEYPAD
6	Enter Account	PRESS	FUNCTKEY
7	Insert Deposit	INSERT	DEPOSSLOT
8	Receive Cash	TAKE	CASHSLOT
9	Receive Receipt	TAKE	RECPTSLOT
10	Retrieve ATM Card	TAKE	CARDSLOT

The sequence of operations for any specific ATM session will ultimately be determined by the combination of hardware and software provided to the user. In addition, sequences may vary slightly within a single ATM system, depending on the particular requirements of the customer. Figures 4.1 and 4.2 depict two flowcharts for standard and forced exit ATM sessions as observed in the field. The activities and their corresponding control positions of a typical ATM session are also given in Table 4.3.

In order to arrive at a typical ATM session, weights must be applied to each of the feasible transaction types according to their frequency-of-use distribution. In a study of weekly ATM usage, (van der Velde, 1982) a total of 1646 transactions were observed, The data collected in this study were analyzed, resulting in a transaction mix as shown in Table 4.4.

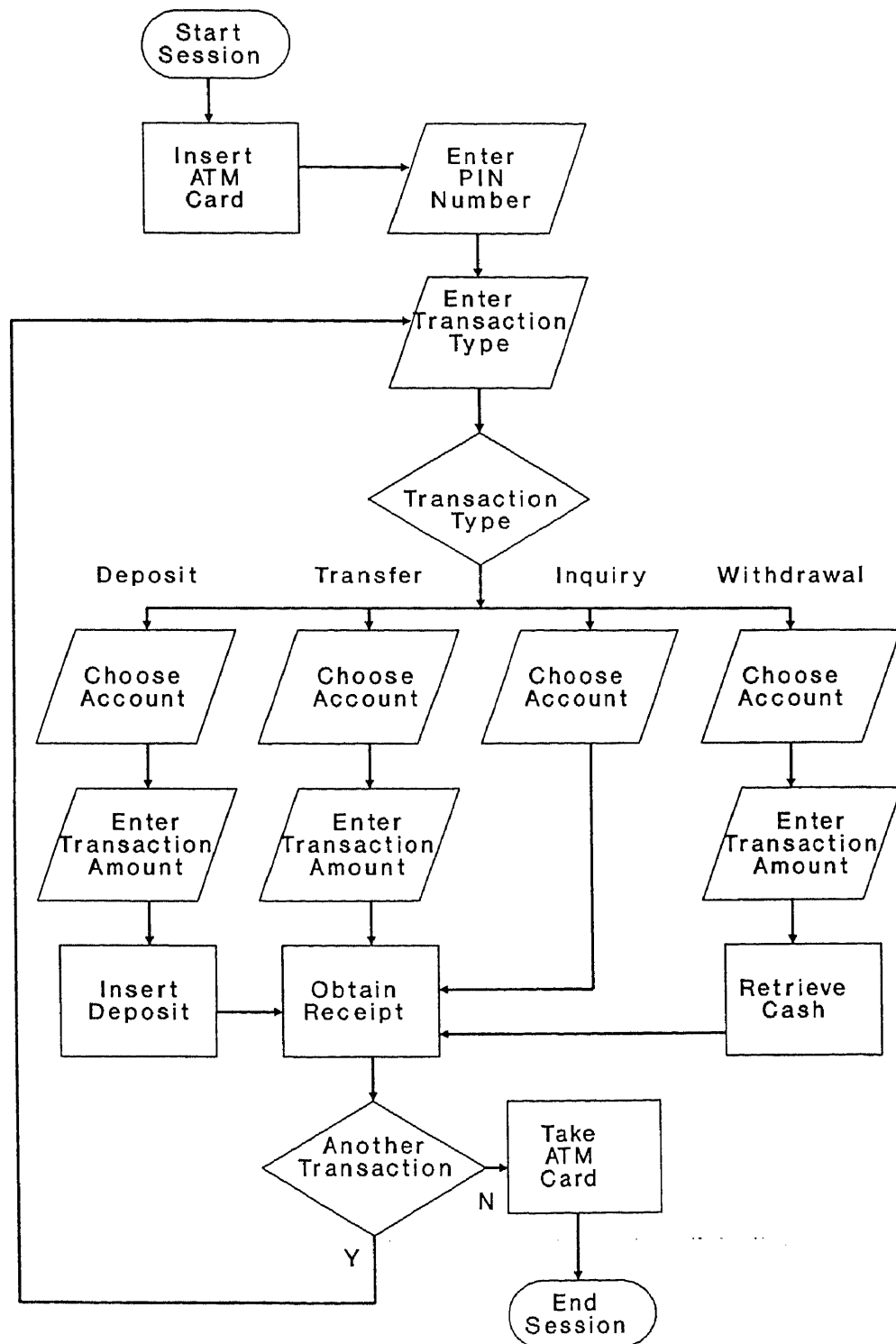

Figure 4.1 Typical ATM Session Flowchart.

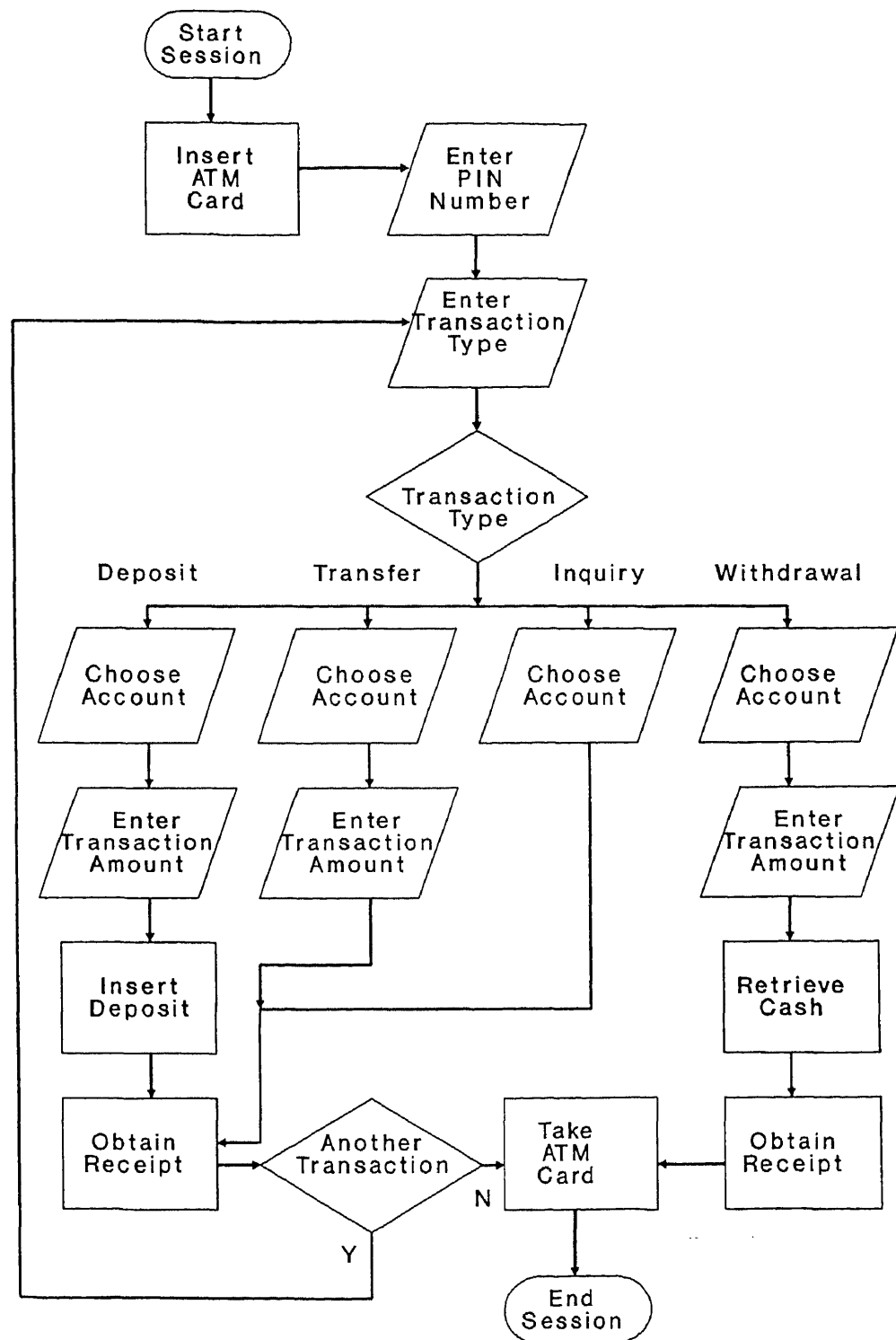

Figure 4.2 Forced Exit ATM Session Flowchart.

Table 4.3 Task Elements and Loci for ATM Transaction Types.

Task No.	Task Element	Object ID	Locus	Included Transactions
1	Insert ATM Card	A	CardSlot	all
2	Enter PIN Number	B	KeyPad	all
3	Choose Transaction	C	FunctKey	all
4	Enter Account	C	FunctKey	all
5	Enter Amount	B	KeyPad	all exc. TR IN
6	Enter Account	C	FunctKey	TR
7	Insert Deposit	D	DeposSlot	CD SD
8	Receive Cash	F	CashSlot	CW SW BW
9	Receive Receipt	E	RecptSlot	all
10	Retrieve ATM Card	A	CardSlot	all

Table 4.4 Distribution of ATM Activities by Transaction Type

Activity No. (i)	Abbrev.	Transaction	Observed Frequency (n)	Relative Frequency $P(i)=n/N$
1	CW	Withdrawal from Checking	760	0.462
2	CD	Deposit to Checking	189	0.115
3	SW	Withdrawal from Savings	131	0.080
4	SD	Deposit to Savings	25	0.015
5	BW	Withdrawal from Bank Card	8	0.005
6	TR	Transfer Between Accounts	97	0.059
7	IN	Balance Inquiry	436	0.265

Notes:

1. Frequency data based on sample size of $N = 1646$ ATM transactions
2. Source: van der Velde (1982)

4.2 ATM Transaction Models

Three models for ATM transaction sequences are considered. For Case I, the simplest and ideal case, it is assumed that no operational errors occur and that only one transaction occurs per ATM session. A more realistic case, Case II, incorporates human errors, but allows only a single transaction per session. Case III is the most realistic situation in which both error probabilities are considered and multiple transactions per ATM session are permitted.

4.2.1 Case I - Ideal Case

In the first and simplest case, tasks are performed in accordance with a pre-defined sequence of activities as shown in Figure 4.3. The possibility of errors is ignored and only one transaction is allowed per session. The activity sequence diagrams are arranged with activities on the nodes and connecting arrows or arcs showing the normal sequences for each type of transaction. The distribution of transaction types is obtained from the typical transaction mix from Table 4.4.

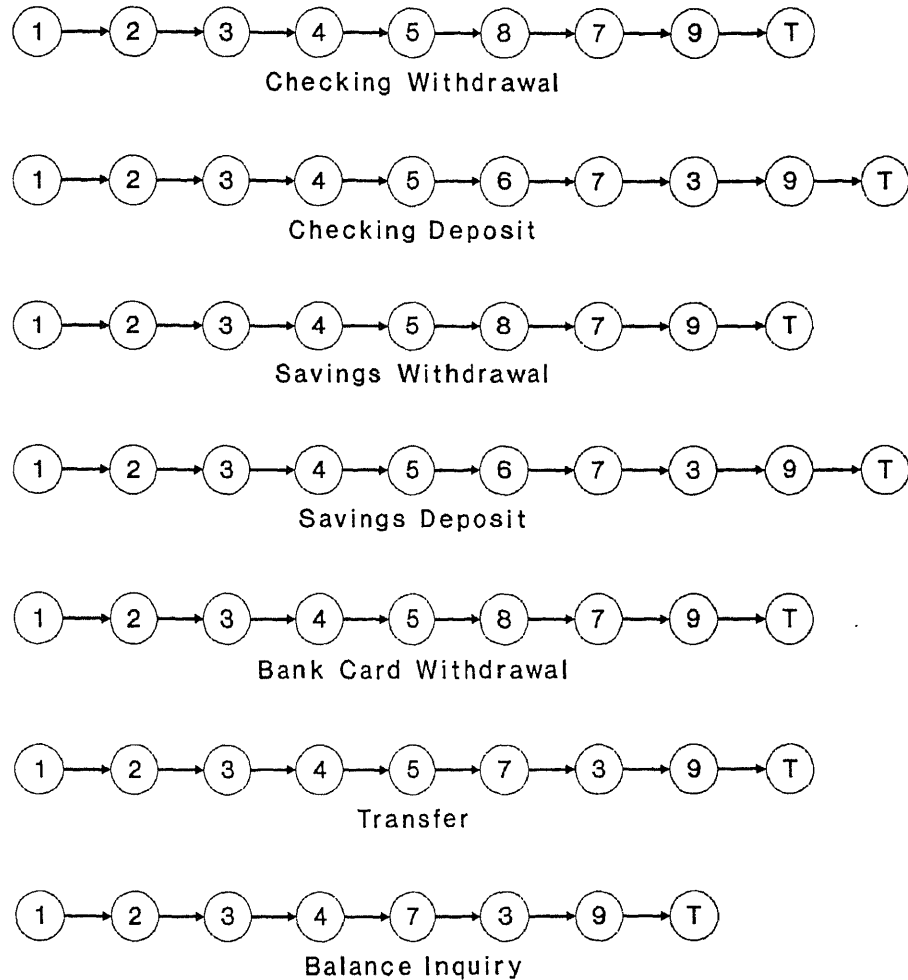

Notes

1. Activities on nodes
2. 1 = Insert card 2 = Enter PIN 3 = Enter transaction type
4 = Choose account 5 = Enter Amount 6 = Insert Deposit
7 = Get Receipt 8 = Get Cash 9 = Take ATM card
3. One transaction allowed per session
4. All activities are performed without errors

Figure 4.3 ATM Activity Sequences (Case I).

4.2.2 Case II - Human Error Model

In the Case II model, the likelihood of human error is introduced (Figure 4.4). The probabilities of certain errors, such as in entering a PIN number or in selecting a function, are derived from the task error rates of Table 3.3. For example, the probability of correct PIN number entry is 0.868, and for function key selection the probability of correct entry is 0.967.

The probabilities for other types of errors can also be estimated. For example, on some machines with horizontal card slots, the ATM card must be inserted with the magnetic stripe down and on the right. Despite (or perhaps because of) the labels on the card slot, incorrect insertion frequently occurs, since three of the four physically possible card orientations are invalid. In the absence of actual card input error statistics, this parameter will be estimated, although it is recommended that any further studies in this area should include the additional research and experimentation to verify the assumptions stated herein. A reasonable estimate is that ATM cards will be correctly inserted the first time in at best 90 percent of sessions..

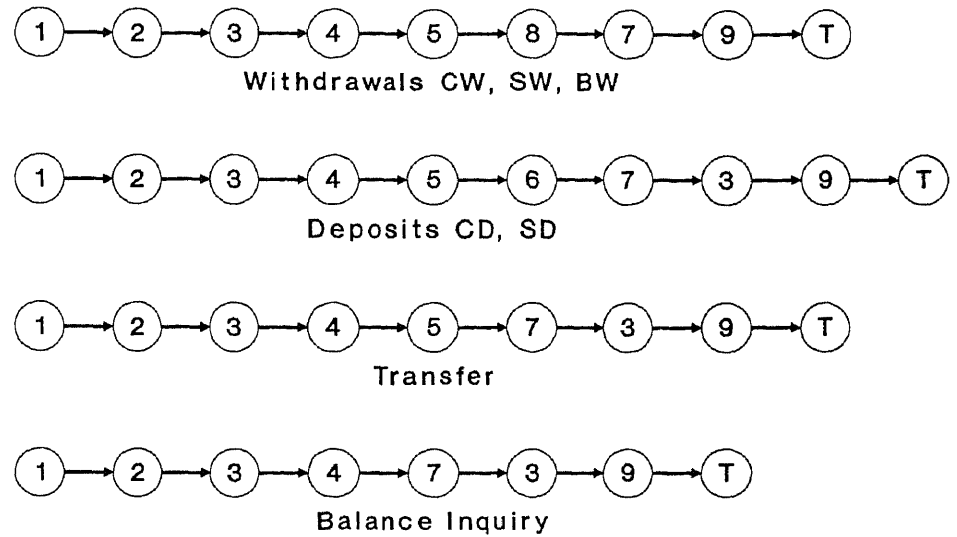

Notes

1. Activities on nodes
2. 1 = Insert card 2 = Enter PIN 3 = Enter transaction type
4 = Choose account 5 = Enter Amount 6 = Insert Deposit
7 = Get Receipt 8 = Get Cash 9 = Take ATM card
3. One transaction allowed per session
4. All transactions are completed once started
5. Probability of ATM card inserted incorrectly = 0.10
6. Probability of incorrect PIN number entry = 0.132
7. Probability of incorrect numeric entry = 0.155
8. Probability of incorrect function selection = 0.033

Figure 4.4 ATM Activity Sequences (Case II).

4.2.3 Case III - Multitransaction Model

In this combined model, the situation is covered in which more than one transaction is allowed in an ATM session (Figure 4.5). The conditional probabilities for multiple transactions can be estimated. The probability of transactions canceled once begun can be estimated from the total transactions completed divided by the total of all transactions started. Since the actual data was not obtainable, it will be assumed for the purpose of calculation that all transactions are completed once started and that no cancellations or other abnormal events are encountered. Those parties with access to ATM transaction records could conduct further research which may yield a more accurate estimate of transaction completion rates. This could be achieved by examining records of all transactions or by analyzing a statistically valid sample.

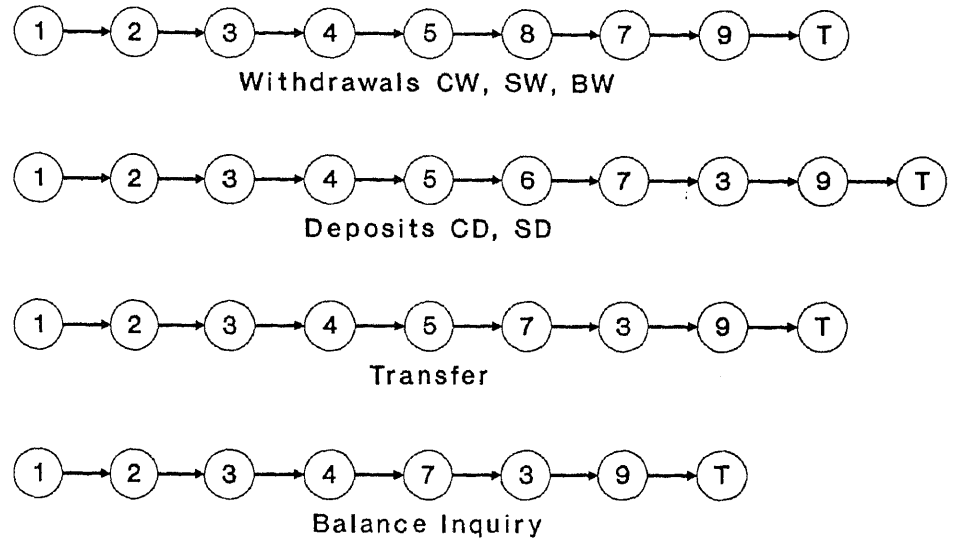

Notes

1. Activities on nodes
2. 1 = Insert card 2 = Enter PIN 3 = Enter transaction type
4 = Choose account 5 = Enter Amount 6 = Insert Deposit
7 = Get Receipt 8 = Get Cash 9 = Take ATM card
3. Multiple transactions ($n = 1$ or $n = 2$) allowed per session
4. All transactions are completed once started
5. Probability of ATM card inserted incorrectly = 0.10
6. Probability of incorrect PIN number entry = 0.132
7. Probability of incorrect numeric entry = 0.155
8. Probability of incorrect function selection = 0.033
9. Conditional probabilities for multiple transactions can be estimated
10. Probability of $n > 2$ transactions is negligible (> 0.02)

Figure 4.5 ATM Activity Sequences (Case III).

4.2.4 Transaction Conditional Probabilities

The likelihood of having a multiple transaction is dependent upon the nature of the first transaction. Transactions involving deposits and inquiries often are followed by another transaction. Many ATM systems, however, automatically end the session after a cash withdrawal, therefore, in such a "forced exit" system the sequence of any withdrawal followed by a deposit or any other transaction is infeasible (See Figure 4.2).

The sequence of transactions in a multiple transaction session can also be estimated. For example, some typical sequences consist of a deposit or an inquiry, followed by a withdrawal from the same account, or an inquiry followed by a deposit to the same account. A less common sequence would be to have two of the same transactions in sequence, for example checking deposit followed by another checking deposit. Also, a withdrawal transaction can be assumed to terminate the session.

If the first transaction in the ATM session is i_1 , the conditional probability of having another transaction (i_2) following in the same session can be determined. Given the first transaction (i_1) and $n = 2$, the probability distributions for the second transaction (i_2) have been estimated according to Table 4.5.

Table 4.5 Conditional Probabilities and Distribution of Two Transactions.

First Transaction (i1)	Probability $P(n=2 i=i1)$	Second Transaction (i2)							See Note #
		CW	CD	SW	SD	BW	TR	IN	
CW	0.000	0.000	0.000	0.000	0.000	0.000	0.000	0.000	(2)
CD	0.200	0.600	0.000	0.020	0.000	0.020	0.060	0.300	(3)
SW	0.000	0.000	0.000	0.000	0.000	0.000	0.000	0.000	(2)
SD	0.200	0.020	0.000	0.600	0.000	0.020	0.060	0.300	(3)
BW	0.000	0.000	0.000	0.000	0.000	0.000	0.000	0.000	(2)
TR	0.200	0.460	0.115	0.080	0.015	0.005	0.060	0.265	(4)
IN	0.500	0.460	0.115	0.080	0.015	0.005	0.060	0.265	(4)

Notes:

1. Probability of occurrence of similar transactions (e.g. CD & SD) in sequence is nil.
2. Multiple transactions following withdrawals are infeasible in forced exit system.
3. Deposit transaction followed by any withdrawal has probability of 0.6, inquiry 0.3, transfer 0.06, deposit to alternate account 0.02.
4. Following inquiry or transfer, standard transaction distribution pattern is assumed to be in effect (data from Van der Velde, 1982).

4.3 ATM Stochastic Models

The activities of the ATM control panel operation model can be thought of as a stochastic process, or random chance process $X(t)$, with the set of user operation activities defined as the sample space S for a random experiment in time. The n elements of the sample space are states within the sample space and, for reasons of simplification, are discrete and countable in number.

In the case of the ATM machine problem, the number of possible discrete activities in a transaction session is finite. Since a one-to-one correspondence exists between the task and the object used in performing the activity, we will define the state space as comprised of the set of spatial positions assumed by the user's hand in operating an ATM. The size of the state space (S) can then be determined by the number of objects or control positions (p), rather than the number of activities (n). Since the expected sequence of operation of each of the p controls is presumably known, probabilities can theoretically be assigned to the operation of each control, based on the last control used.

Given a small and arbitrary time interval Δt , it is possible to state all of the relationships between control functions in the form of an $n \times n$ stochastic matrix.

4.3.1 Transition Probabilities

The ATM transition probabilities, obtained by studying actual usage patterns, will most likely vary depending on the particular model of ATM and the

controlling software programs. A typical ATM model will be used for illustrative purposes and solved as a case study. Although the results for a given model will not necessarily apply universally, the same basic techniques can be employed to find a solution for any other specific ATM configuration.

Based on the activity sequences and weighting of each type of transaction, a transition diagram can be developed. In the diagram for Case I (Figure 4.6), nodes indicate the sites of activities and the directed arcs indicate valid branch paths connecting activities. The values along each arc denote, for each source node i , the probabilities of performing the destination activity on node j , given that the source activity has occurred. Since all ATM sessions begin with a common starting point (the insertion of the ATM card), we can, by studying the resulting activity sequence generator, obtain important and useful control layout design information.

Since it can be reasonably assumed that the relationships between control functions stay unchanged over time and are independent of prior events, the system is said to exhibit the properties of both stationarity and lack of memory. A stochastic process exhibiting both properties has the characteristic known as first-order dependence. In other words, the conditional distribution of $X(t)$ is dependent only upon $X(t_n)$ which is the most recently determined value of the state of the process.

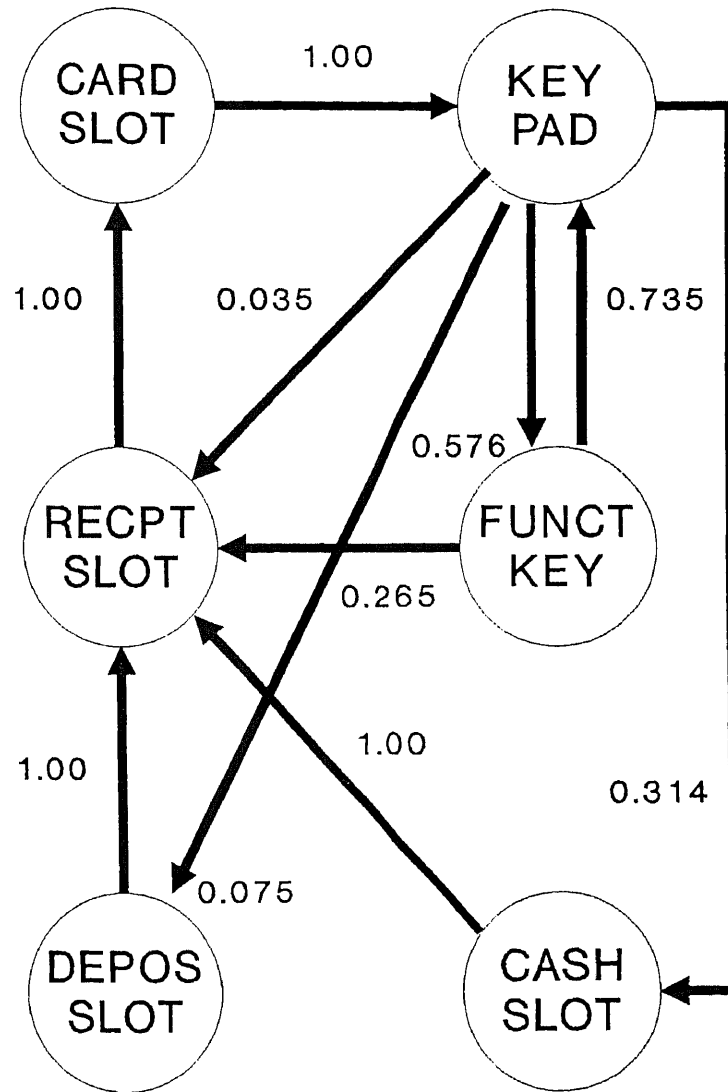

Figure 4.6 ATM Transition Diagram (Case I).

This type of dependence is called Markov-dependence, and a Markov dependent system is referred to as Markovian. As a consequence of the Markov-dependence of the process, we can define the one-step transition matrix as P , and the elements of P as p_{ij} , where i is the location state at time period t , and j is the location state at time period $(t + \Delta t)$. Each element p_{ij} represents the probability that, in a single time period (epoch), the system moves from state i to state j . The one-step transition probability matrices (Markov chains) for the four transaction types are given in Tables 4.6 through 4.9.

Table 4.6 One-Step Transition Matrix for ATM Withdrawals.

Locus	Object	A	B	C	D	E	F
CardSlot	A	0.000	1.000	0.000	0.000	-	0.000
KeyPad	B	0.000	0.000	0.500	0.000	-	0.500
FunctKey	C	0.000	1.000	0.000	0.000	-	0.000
DeposSlot	D	-	-	-	-	-	-
RecptSlot	E	1.000	0.000	0.000	0.000	-	0.000
CashDisp	F	0.000	0.000	1.000	0.000	-	0.000

Table 4.7 One-Step Transition Matrix for ATM Deposits.

Locus	Object	A	B	C	D	E	F
CardSlot	A	0.000	1.000	0.000	0.000	0.000	-
KeyPad	B	0.000	0.000	0.500	0.500	0.000	-
FunctKey	C	0.000	1.000	0.000	0.000	0.000	-
DeposSlot	D	0.000	0.000	0.000	0.000	1.000	-
RecptSlot	E	1.000	0.000	0.000	0.000	0.000	-
CashDisp	F	-	-	-	-	-	-

Table 4.8 One-Step Transition Matrices for ATM Transfers.

Locus	Object	A	B	C	D	E	F
CardSlot	A	0.000	1.000	0.000	-	0.000	-
KeyPad	B	0.000	0.000	0.500	-	0.500	-
FuncKey	C	0.000	1.000	0.000	-	0.000	-
DeposSlot	D	-	-	-	-	-	-
RecptSlot	E	1.000	0.000	0.000	-	0.000	-
CashDisp	F	-	-	-	-	-	-

Table 4.9 One-Step Transition Matrix for ATM Inquiries.

Locus	Object	A	B	C	D	E	F
CardSlot	A	0.000	1.000	0.000	-	0.000	-
KeyPad	B	0.000	0.000	1.000	-	0.000	-
FuncKey	C	0.000	0.000	0.000	-	1.000	-
DeposSlot	D	-	-	-	-	-	-
RecptSlot	E	1.000	0.000	0.000	-	0.000	-
CashDisp	F	-	-	-	-	-	-

4.3.2 Composite Transition Diagrams

A composite transition diagram is developed for each of the three models describing the probabilities of transition from each node to every other nodes and incorporate weighting factors derived from the transaction mix as previously defined. The numbers adjacent to the arcs show the number of transitions (in thousands) from the source node to the destination node, given that a simulated 1000 visits were made to the source node.

For the second case, the model formulation is revised slightly. An additional keypad node (B') is added to represent the re-visit to the keypad to enter a numeric amount. The rest of the formulation is as in Case I. The transition diagram for the Case II model is given in Figure 4.7.

In Case III, the multiple transaction model, three more nodes have been added. To allow for multiple transaction re-visits, an additional keypad node (B''), a function key node (C'), and a receipt slot node (E') are introduced. The transition diagram for the Case III model is shown in Figure 4.8.

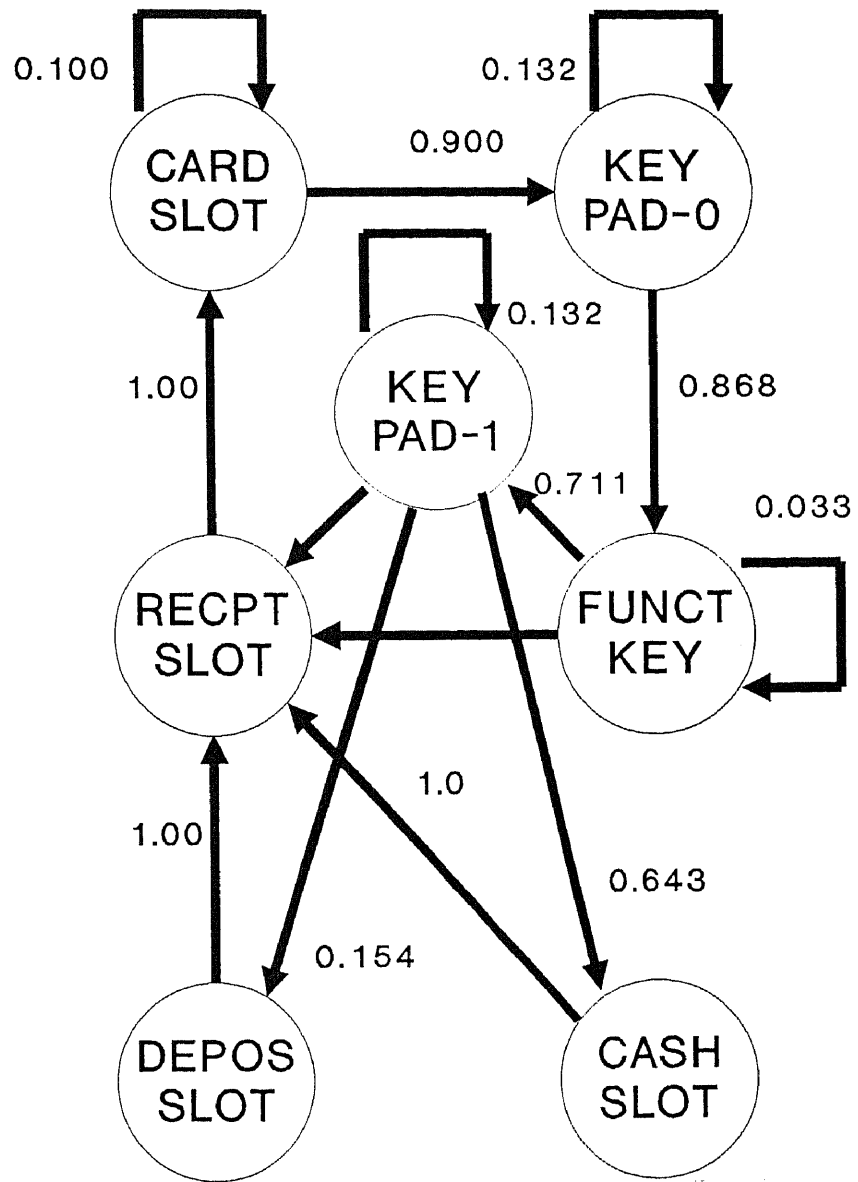

Figure 4.7 ATM Transition Diagram (Case II).

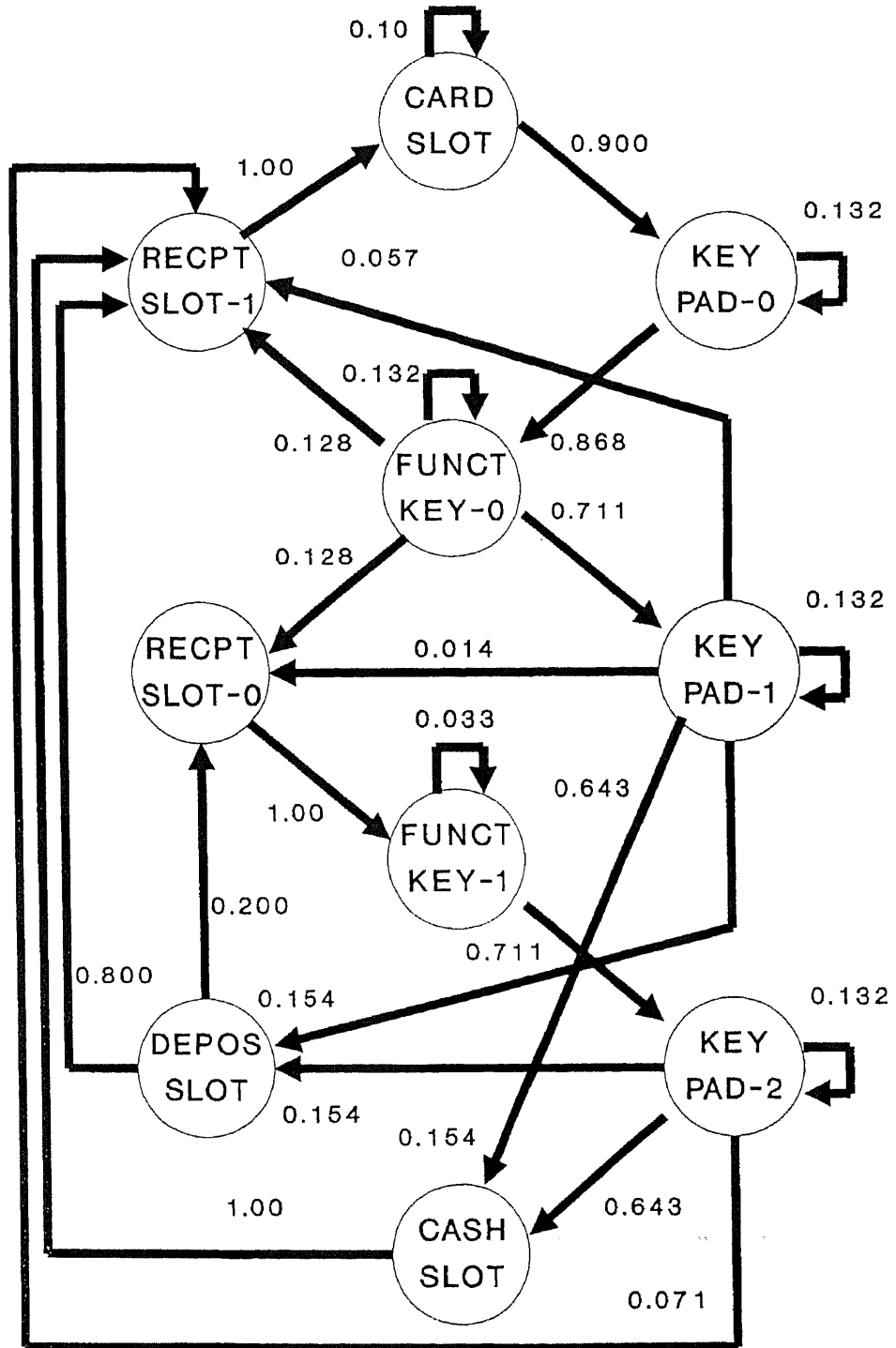

Figure 4.8 ATM Transition Diagram (Case III).

4.3.3. Composite Transition Matrices

The one-step transition matrix for the composite ATM session can be developed directly from the transition diagrams of Figures 4.6 thru 4.8. The listed values are the conditional probabilities for each arc, calculated according to:

$$P_{ij} = F_{ij} / T_i \quad (4.1)$$

where:

P_{ij} = probability of transition from node i to j

F_{ij} = frequency of transactions from node i to j

T_i = total number of transactions leaving node i

Using the values for the Case I model (Figure 4.6) as an example, a one-step transition matrix (Markov chain) is constructed, as shown in Table 4.10. The same technique is repeated for Cases II and III, with the resulting transition matrices given in Tables 4.11 and 4.12.

Table 4.10 Composite Transition Matrix - Case I.

Locus	Object	A	B	C	D	E	F
CardSlot	A	0.000	1.000	0.000	0.000	0.000	0.000
KeyPad	B	0.000	0.000	0.576	0.075	0.035	0.314
FunctKey	C	0.000	0.735	0.000	0.000	0.265	0.000
DeposSlot	D	0.000	0.000	0.000	0.000	1.000	0.000
RecptSlot	E	1.000	0.000	0.000	0.000	0.000	0.000
CashDisp	F	0.000	0.000	0.000	0.000	1.000	0.000

Table 4.11 Composite Transition Matrix - Case II.

Locus	Object	A	B	B'	C	D	E	F
CardSlot	A	0.100	0.900	0.000	0.000	0.000	0.000	0.000
KeyPad	B	0.000	0.132	0.000	0.868	0.000	0.000	0.000
KeyPad-1	B'	0.000	0.000	0.132	0.000	0.154	0.071	0.643
FunctKey	C	0.000	0.000	0.711	0.033	0.000	0.256	0.000
DeposSlot	D	0.000	0.000	0.000	0.000	0.000	1.000	0.000
RecptSlot	E	1.000	0.000	0.000	0.000	0.000	0.000	0.000
CashDisp	F	0.000	0.000	0.000	0.000	0.000	1.000	0.000

Table 4.12 Composite Transition Matrix - Case III.

Object	A	B	B'	B''	C	C'	D	E	E'	F
A	0.100	0.900	0.000	0.000	0.000	0.000	0.000	0.000	0.000	0.000
B	0.000	0.132	0.000	0.000	0.868	0.000	0.000	0.000	0.000	0.000
B'	0.000	0.000	0.132	0.000	0.000	0.000	0.154	0.014	0.057	0.643
B''	0.000	0.000	0.000	0.132	0.000	0.000	0.154	0.000	0.071	0.643
C	0.000	0.000	0.711	0.000	0.033	0.000	0.000	0.128	0.128	0.000
C'	0.000	0.000	0.000	0.711	0.000	0.033	0.000	0.000	0.256	0.000
D	0.000	0.000	0.000	0.000	0.000	0.000	0.000	0.200	0.800	0.000
E	0.000	0.000	0.000	0.000	0.000	1.000	0.000	0.000	0.000	0.000
E'	1.000	0.000	0.000	0.000	0.000	0.000	0.000	0.000	0.000	0.000
F	0.000	0.000	0.000	0.000	0.000	0.000	0.000	0.000	1.000	0.000

Legend

A	CardSlot	C'	FunctKey-1
B	Keypad-0	D	DeposSlot
B'	Keypad-1	E	RecptSlot-0
B''	Keypad-2	E'	RecptSlot-1
C	FunctKey-0	F	CashDisp

4.3.4 Steady-State Solution

If a stochastic system is Markovian, stationary, and well behaved, or ergodic (i.e. does not have absorbing states from which the system cannot exit), a steady-state solution can be found. The steady-state solution of a Markov chain is an n -element vector which describes the percentage of time the system can be observed in each of the n states, over the long run. The steady-state solution for the ATM problem can be obtained by analyzing the composite one-step transition matrix (Table 4.12) using either numerical or algebraic techniques. A sample calculation demonstrating the method of determining a steady-state solution is presented in the Appendix.

The steady-state solutions for the Markov chains of each separate transaction type and for the composite cases were determined. The results were computed numerically by raising each $n \times n$ stochastic matrix to a high-numbered power, and then multiplying the transpose of any state probability vector (a $1 \times n$ stochastic vector), by the result. In this case, 256 iterations were sufficient to reach convergence, and the computations could be performed in a reasonable amount of time (less than 30 minutes for the example shown in the Appendix). The steady-state solutions for the individual transaction types, and a weighted solution based on transaction mix are given in Table 4.13. The steady-state solution vectors for the composite matrices in Tables 4.10 through 4.12, representing Cases I, II, and III, are also given in Table 4.13.

Table 4.13 Steady-State Solutions for ATM Models.

		Steady-State Vector					
Model	Case	A CardSlot	B KeyPad	C FnctKey	D DepoSlot	E RcptSlot	F CashDisp
Individual	Withdrawal	0.0000	0.4000	0.4000	0.0000	0.0000	0.2000
	Deposit	0.3330	0.0000	0.3333	0.3333	0.0000	0.0000
	Transfer	0.1999	0.3999	0.1999	0.0000	0.1999	0.0000
	Inquiry	0.2500	0.2500	0.2500	0.0000	0.2500	0.0000
	Weighted Average	0.1810	0.3550	0.1780	0.0490	0.1720	0.0750
Composite	Case I	0.1853	0.3198	0.1854	0.0241	0.1843	0.1010
	Case II	0.1909	0.3435	0.1777	0.0224	0.1718	0.0936
	Case III	0.1725	0.3333	0.1886	0.0238	0.1824	0.0993

The elements of the steady-state solution vectors can be interpreted to represent the proportion of transaction time that, in the long run, the user can be expected to spend in each of the states of the system. In the Case I situation for example, the steady-state vector was found to be:

$$P^{(256)} = [0.1853, 0.3198, 0.1854, 0.0241, 0.1843, 0.1010] \quad (4.2)$$

As such, the user could be expected to spend 18.53% of his work time at the card slot, 31.98% at the keypad, 18.54% at the function key, 2.41% at the deposit slot, 18.43% at the receipt dispenser, and 10.10% at the cash dispenser. Since additional nodes were introduced in the Case II and Case III models, representing the same point in space, their separate state probabilities have been combined. This information will be utilized in the final solution phase of the problem.

4.4 Arm Kinematics

The human arm, like its industrial robot counterpart, is a manipulating device consisting of several rigid bodies (links), connected in series by revolute joints. The angular motion of joints results in relative motion of the links. In operation, arm motions typically consists of independent movements designed to place a tool or other object to any point within the arm's work volume.

The independent motions of an arm are referred to as degrees of freedom. Six degrees of freedom are required to reach a given point in space with a given

orientation. The human arm has exactly six degrees of freedom: two in the shoulder, one at the elbow, and three at the wrist (Paul, 1981). If we disregard the requirement for arbitrary wrist orientation and affix the end effector to the end of the arm, only three degrees of freedom are needed. The procedure for finding the joint solution for a simple three degree of freedom arm is described in the Appendix.

4.4.1 Simple Manipulators

The approach to describing the location of arm links with respect to a fixed reference point requires the use of vector and matrix algebra. A 3 x 3 rotation matrix is defined as a transformation matrix to map the rotated coordinate system to a reference coordinate system with the same origin. In order to accommodate translation and scaling, a fourth component or coordinate is introduced. If the vector $O = (p_x, p_y, p_z)^T$ is used to represent the position of the endpoint in 3-D space, then vector $P = (wp_x, wp_y, wp_z)^T$ are homogeneous coordinates encompassing rotation and translation (Lee, 1982). By matrix multiplication, the result of combinations of rotations and translations can be determined. From Paul (1982), using the coordinate frames shown in Figure 4.9, the general form of the 4 x 4 transformation matrix is given by Equation 4.3.

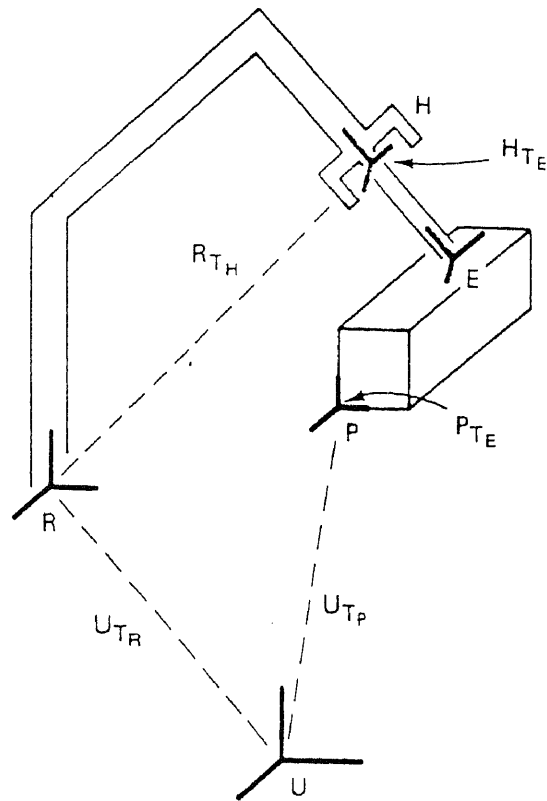

Figure 4.9 Coordinate Frames for Simple Manipulator (From Paul, 1981).

Given:

Roll = $R(\phi_z)$ = rotate ϕ_z about z

Pitch = $P(\phi_y)$ = rotate ϕ_y about y

Yaw = $Y(\phi_x)$ = rotate ϕ_x about x

the combination is

$$\text{RPY}(\phi_z, \phi_y, \phi_x) = \text{Rot}(z, \phi_z) \text{Rot}(y, \phi_y) \text{Rot}(x, \phi_x)$$

$$\text{RPY}(\phi_z, \phi_y, \phi_x) =$$

$$\begin{array}{cccc} c\phi_z c\phi_y & c\phi_z s\phi_y s\phi_x - s\phi_z c\phi_x & c\phi_z s\phi_y c\phi_x + s\phi_z s\phi_x & 0 \\ s\phi_z c\phi_y & s\phi_z s\phi_y s\phi_x + c\phi_z c\phi_x & s\phi_z s\phi_y c\phi_x - c\phi_z s\phi_x & 0 \\ -s\phi_y & c\phi_y s\phi_x & c\phi_y c\phi_x & 0 \\ 0 & 0 & 0 & 1 \end{array} \quad (4.3)$$

Referring to the coordinate frames in Figure 4.9, the base is the origin of frame R, whose location is presumably known relative to a universe frame U. The location of the end effector relative to the universe frame can be determined by the transform: $U_T_E = U_T_R \cdot R_T_H \cdot H_T_E$. Also, the same point in space can be found from $U_T_E = U_T_P \cdot P_T_E$. The desired transform that identifies the location of the end effector (hand frame H) with respect to the robot base (robot frame R) is R_T_H , and may be found by:

$$R_T_H = U_T_R^{-1} \cdot U_T_P \cdot P_T_E \cdot H_T_E^{-1} \quad (4.4)$$

Due to the special nature of robot transformation matrices, inversion can be accomplished by use of a specialized techniques. If the elements of a 4 x 4 homogeneous transform T are:

$$T = \begin{bmatrix} n_x & o_x & a_x & p_x \\ n_y & o_y & a_y & p_y \\ n_z & o_z & a_z & p_z \\ 0 & 0 & 0 & 1 \end{bmatrix} \quad (4.5)$$

The inverse of T is found very simply by rearranging elements and computing three dot products (Paul, 1982):

$$T^{-1} = \begin{bmatrix} n_x & n_y & n_z & -p \cdot n \\ o_x & o_y & o_z & -p \cdot o \\ a_x & a_y & a_z & -p \cdot a \\ 0 & 0 & 0 & 1 \end{bmatrix} \quad (4.6)$$

where,

$$p \cdot n = p_x n_x + p_y n_y + p_z n_z$$

$$p \cdot o = p_x o_x + p_y o_y + p_z o_z$$

$$p \cdot a = p_x a_x + p_y a_y + p_z a_z$$

4.4.2 Multiple Link Manipulators

In order to analyze the typical system comprised of multiple links, the relationships between links must be described. In order to describe the translational and rotational relationships between the adjacent links, Denavit and

Hartenberg (1955) introduced an algorithm (D-H method) for establishing coordinate systems for each link. The details of the eleven step D-H procedure are given in Section 4.4.4. Using the D-H representation, a 4 x 4 homogeneous transformation matrix is established to represent each link's coordinate system with respect to the previous link's coordinate system. The labeling of the links typically begins at the base and continues until the end effector is reached.

Once the D-H coordinate system has been established for each link, a homogeneous transformation matrix (A_{i-1}^i) can be found to describe the i th coordinate frame with respect to the $(i-1)$ th frame (Lee, 1982). The homogeneous matrix (T_0^i) specifies the position of the end point of link i with respect to the base coordinate system. This matrix can be found for any link i in the system by chain multiplication of D-H transformation matrices for adjacent links 0 to i according to:

$$T_0^i = \prod_{j=1}^i A_{j-1}^j, \quad (i = 1, 2, \dots, n) \quad (4.7)$$

For example, given a manipulator with six joints, such as the PUMA arm (shown in Figure 4.10), the coordinate transformation matrices are developed (Figure 4.11). By direct kinematics the arm solution $T = A_0^6$, was found (Lee, 1982).

$$T = A_0^6 = A_0^1 \cdot A_1^2 \cdot A_2^3 \cdot A_3^4 \cdot A_4^5 \cdot A_5^6 \quad (4.8)$$

The steps in the solution are given in the Appendix.

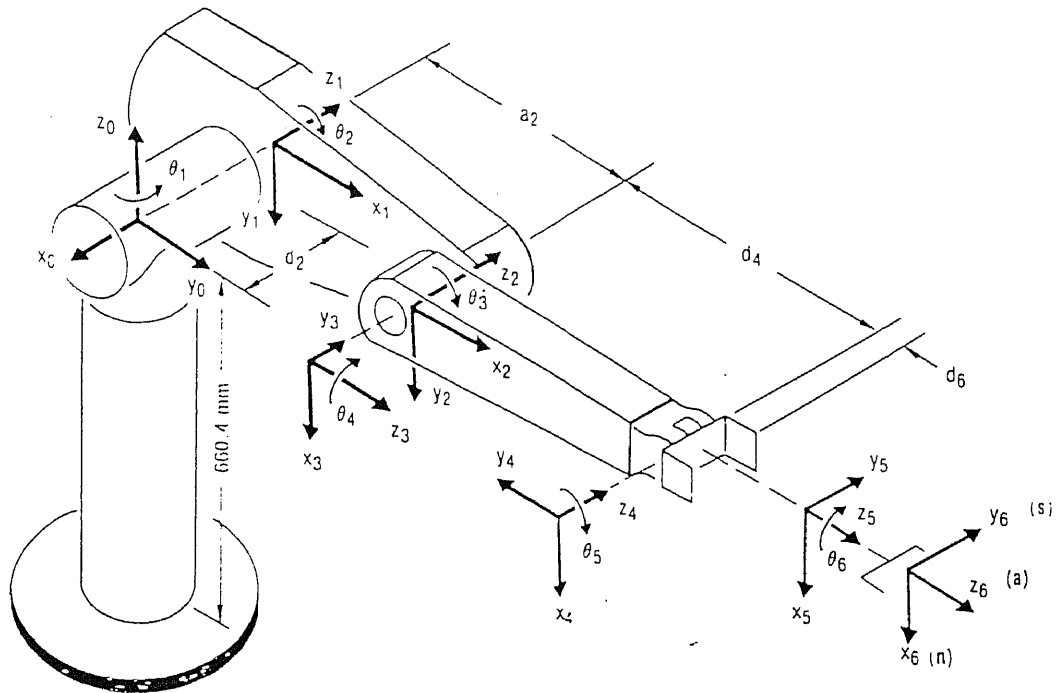

Figure 4.10 Link Coordinate Systems for Six-Joint PUMA Arm (adapted from Lee, 1982).

$$A_{i-1}^i = \begin{bmatrix} C\theta_i & -C\theta_i S d_i & S\theta_i S d_i & a_i C\theta_i \\ S\theta_i & C\theta_i S d_i & -S\theta_i S d_i & a_i S\theta_i \\ 0 & S\theta_i & C\theta_i & d_i \\ 0 & 0 & 0 & 1 \end{bmatrix}$$

$$A_0^1 = \begin{bmatrix} C_1 & 0 & -S_1 & 0 \\ S_1 & 0 & C_1 & 0 \\ 0 & -1 & 0 & 0 \\ 0 & 0 & 0 & 1 \end{bmatrix} \quad A_1^2 = \begin{bmatrix} C_2 & -S_2 & 0 & a_2 C_2 \\ S_2 & C_2 & 0 & a_2 S_2 \\ 0 & 0 & 1 & d_2 \\ 0 & 0 & 0 & 1 \end{bmatrix}$$

$$A_2^3 = \begin{bmatrix} C_3 & 0 & S_3 & 0 \\ S_3 & 0 & -C_3 & 0 \\ 0 & 1 & 0 & 0 \\ 0 & 0 & 0 & 1 \end{bmatrix} \quad A_3^4 = \begin{bmatrix} C_4 & 0 & -S_4 & 0 \\ S_4 & 0 & C_4 & 0 \\ 0 & -1 & 0 & d_4 \\ 0 & 0 & 0 & 1 \end{bmatrix}$$

$$A_4^5 = \begin{bmatrix} C_5 & 0 & S_5 & 0 \\ S_5 & 0 & -C_5 & 0 \\ 0 & 1 & 0 & 0 \\ 0 & 0 & 0 & 1 \end{bmatrix} \quad A_5^6 = \begin{bmatrix} C_6 & -S_6 & 0 & 0 \\ S_6 & C_6 & 0 & 0 \\ 0 & 0 & 1 & d_6 \\ 0 & 0 & 0 & 1 \end{bmatrix}$$

Figure 4.11 Transformation Matrices for Six-Joint PUMA Arm (Adapted from Lee, 1982).

4.4.3 Inverse Kinematics (Joint Solution)

Since the arm is usually comprised of links of fixed-length, the motion is achieved by varying the joint angles. To control the position of the end effector in space, the inverse kinematic solution must be found. The geometric approach is used to find the joint angle vector $(\theta = \theta_1, \theta_2, \dots, \theta_i)^T$ (Paul, 1981). The procedure is to first find a position vector pointing from the shoulder to the wrist. This is then used to derive the solution for the other joints. The generalized solution method is given in Paul (1981), however, it is relatively complicated. Other simplified approaches can be used in specific cases, such as the solution provided by Lee (1982) for the six-joint PUMA robot.

The direct kinematics problem is always solvable; that is, the position and orientation of the end effector can always be computed. However, the inverse problem is not always solvable, since the configuration of the manipulator may not allow all points in space to be reached. In addition, a single unique solution does not exist for systems with more than one joint. Given a two-link articulated arm, the solution algorithm finds that α_2 and α_3 can each be positive or negative in sign (Lee, 1982). This results in the four configurations as shown in Figure 4.12.

The first two configurations, in which α_2 and α_3 have different signs, are immediately dismissed because they imply that the links are disconnected. The last two configurations, however, are feasible as long as none of the angles violate any of the manipulator's joint constraints (Paul, 1981).

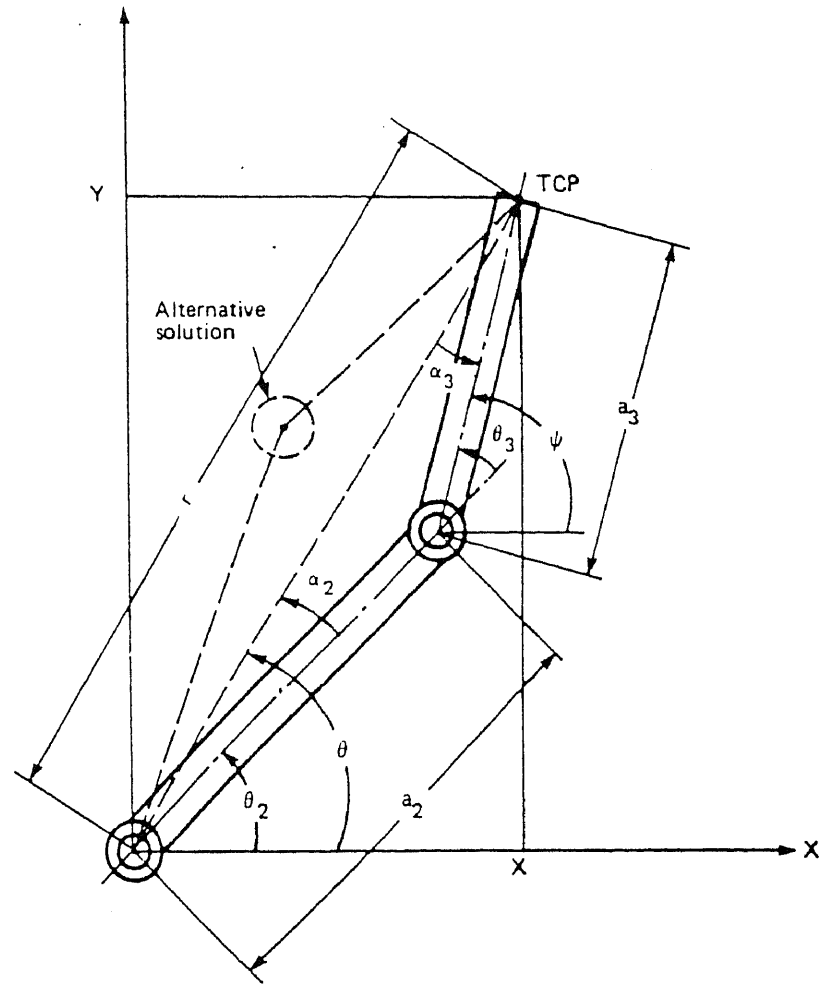

Figure 4.12 Two-Link Articulated Arm (Paul, 1982).

In comparison with a robot manipulator, the likelihood of multiple configurations in the human arm is less, since human ranges of motion are usually limited to only positive angles, while robot manipulator ranges are less restrictive.

4.4.4 Denavit-Hartenberg Algorithm

The method of representing coordinate systems for multiple link manipulators, described by Denavit and Hartenberg (1955), uses matrices to describe adjacent link coordinate systems with respect each other. The representation of a rigid link depends on four parameters associated with each link as follows:

$\theta_i =$ the joint angle from the x_{i-1} axis to the x_i axis about the z_{i-1} axis (using the right-hand rule).

$d_i =$ the distance from the origin of the $(i-1)$ th coordinate frame to the intersection of the z_{i-1} axis with the x_i axis along the z_{i-1} axis.

$a_i =$ the offset distance from the intersection of the z_{i-1} axis with the x_i axis to the origin of the i th frame along the x_i axis (shortest distance between the z_{i-1} and z_i axes).

$\alpha_i =$ the offset angle from the z_{i-1} to the z_i axis about the x_i axis (using the right-hand rule).

For rotary joints, d_i , a_i , and α_i are the joint parameters which remain constant, while θ_i is the joint variable that changes when link i moves. Given a manipulator with n degrees of freedom, the D-H algorithm establishes coordinate

systems for each link in the manipulator. The links are numbered starting at the base and ending at the end effector, and the relationship between adjacent links are represented by 4 x 4 homogeneous transformation matrices. The steps of the algorithm are numbered D1 through D11 as follows (Lee, 1982):

- D1. Establish the base coordinate system. Establish a right-hand orthonormal coordinate system (x_0, y_0, z_0) at the supporting base with the z_0 axis lying along the axis of motion of joint 1.
- D2. Initialize and loop. For each $i, i = 1, \dots, n$, perform steps D3 to D6.
- D3. Establish joint axis. Align the z_i axis with the axis of motion (rotary or sliding) of joint $i+1$.
- D4. Establish the origin of the i th coordinate system. Locate the origin of the i th coordinate system at the intersection of the z_i and z_{i-1} axes or at the intersection of common normals between the z_i and z_{i-1} and the z_i axis.
- D5. Establish x_i axis. Establish $x_i = (z_{i-1} \times z_i) / \|z_{i-1} \times z_i\|$ or along the common normal between the z_{i-1} and z_i axes when they are parallel.
- D6. Establish y_i axis. Assign $y_i = (z_i \times x_i) / \|z_i \times x_i\|$ to complete the right-hand coordinate system. Extend the z_i and x_i axes if necessary for steps D8 to D11.

- D7. Find joint and link parameters. For each $i, i = 1, \dots, n$, perform steps D8 to D11.
- D8. Find d_i , the distance from the origin of the $(i-1)$ th coordinate system to the intersection of the z_{i-1} axis and the x_i axis along the z_{i-1} axis.
- D9. Find a_i , the distance from the intersection of the z_{i-1} axis and the x_i axis to the origin of the i th coordinate system along the x_i axis.
- D10. Find θ , the angle of rotation from the x_{i-1} axis to the x_i axis about the z_{i-1} axis.
- D11. Find α , the angle of rotation from the z_{i-1} axis to the z_i axis about the x_i axis.

4.5 Formulation of Linear Assignment Model

The steady-state solution set for a control function activity is first used to determine the frequency of use for a given control. Each activity in ATM operation requires a predictable number of operations or tasks (T_n), for example a cash withdrawal from checking requires 7 tasks. Therefore, knowing the distribution of transaction types, the expected number of ATM tasks, $E(T)$, required to perform one transaction is found according to equation 4.9.

$$E(T) = \sum_{i=1}^n [P_i T_i] \quad (4.9)$$

where,

$E(T)$ = expected number of ATM tasks

n = number of operations

P_i = probability of transaction type i

T_i = number of tasks used in performing operation i

4.6 Numerical Arm Solution

The numerical solution of arm and shoulder joint angles given spatial coordinates for the control panel problem is found by computer with the aid of the MATHCAD software package. The algorithm used is an implementation of the Levenberg-Marquardt (L-M) method, a quasi-Newtonian variation of the gradient method (Anderson, 1989). At each step, an estimate is made of the first partial derivatives of the error function $f(x)$ with respect to the variable to be solved, creating a Jacobian matrix J . Next, the matrix function $J \cdot s = -f(x)$ is solved for the step vector s , where s is the vector of unknown variables. If the step vector can be found, then $(x + s)$ becomes the new value of x .

In the event that this calculation fails because the matrix J cannot be inverted, an additional condition is added - to minimize the quantity

$$\sum_j D_j^2 \cdot s_j^2 \quad (4.10)$$

where D is a vector of weight factors computed from the norms of matrix J . The algorithm terminates when any of the following conditions is met:

1. It is no longer possible to significantly reduce the value of the norm of the error vector, relative to the tolerance level (TOL) currently set within the program.
2. The value of s becomes relatively close to zero (closer than the larger of TOL and $TOL \cdot |x|$).
3. The program exceeds the limit of the number of calculations without returning an answer. The function is determined to be non-converging in nature.

CHAPTER 5 CASE STUDY - ATM CONTROL PANEL DESIGN

A practical case study is presented in which, given a set of parameters and assumptions, an efficient layout of ATM control panel can be designed, based on the objective of minimizing the fatigue rate.

5.1 Problem Definition

The problem is described according to the following seven step procedure as follows:

1. The user population is determined and basic design parameters are defined. The design population has been determined to be right-handed 5th percentile females. From the anthropometric data, (NASA, 1978; Rodgers, 1986), the shoulder height is 132.9 cm (52.3 in.), and eye height is 151.4 cm (59.6 in.) as shown in Figure 5.1. The shoulder width (w) is 39 cm (15.36 in.) (NASA, 1978). The upper arm length (lateral epicondyle to acromion) (A) is 34.1 cm (13.4 in.), and the lower arm length (lateral epicondyle to fist, plus half of the hand length) (B) is 44.0 cm (17.32 in.) as shown in Figure 5.2.

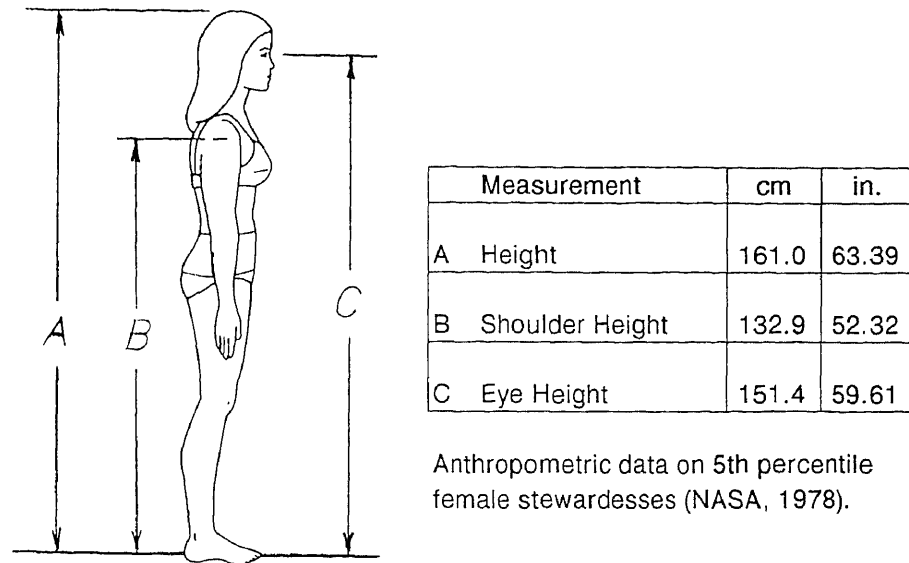

Figure 5.1 Heights of 5th Percentile Female Stewardesses (Adapted from NASA, 1978).

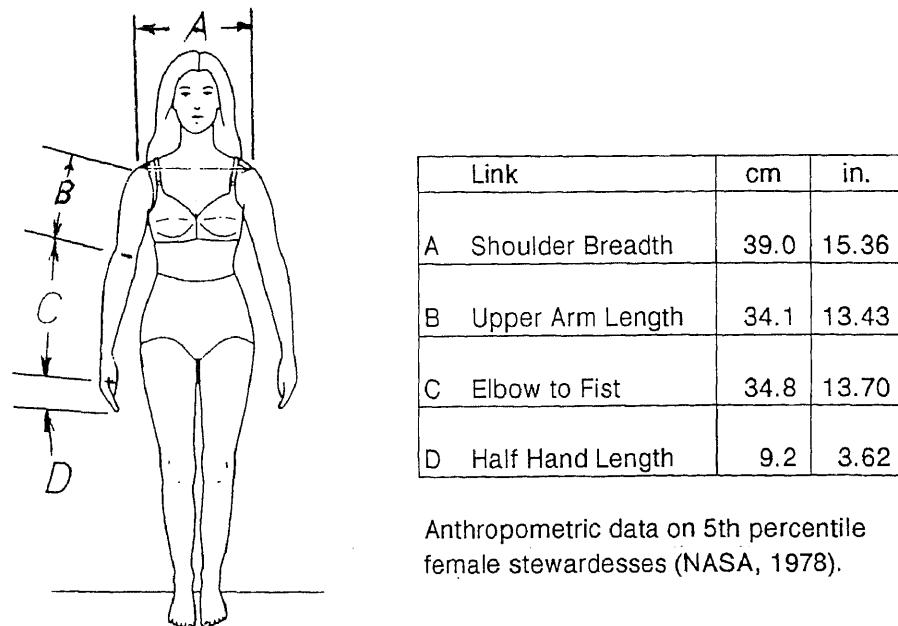

Figure 5.2 Link Lengths for 5th Percentile Females (Adapted from NASA, 1978; and Rodgers, 1986).

2. A spatial coordinates system is defined with the shoulder as the point of reference origin as shown in Figure 5-3. With respect to a standing operator the x-axis is horizontal from left to right, the y-axis is forward and back, and the z-axis is vertical. In agreement with the "right-hand rule," the sign conventions are: positive x is to the right, positive y is forward, and positive z is up.
3. The rotation angles for the shoulder-arm configuration are defined as shown in Figure 5.3. The angle of rotation of the upper arm in the y-z plane is called the shoulder forward flexion angle and given variable θ . The angle of rotation of the elbow (ϕ) is called the elbow flexion to extension angle. The rotation angle (δ) of the upper arm in the x-y plane (the plane of the chest) is called the shoulder horizontal flexion angle.
4. The range of feasible panel coordinate values is defined (See Figure 5.4). The x value is defined as the horizontal distance from the center of the right shoulder joint to the point on the control panel. In this problem the x coordinate will vary from -21.68, rounded to (-21), to +6.32, rounded to (+6). The y value is defined as the distance from the center of the shoulder joint in a direction normal to the plane of the control panel. With a simple vertical planar control panel, the y coordinates will be fixed at +18 inches. The z value is defined as the vertical distance from the center of the shoulder joint to the point on the control panel. In this problem the z coordinate can range in value from -11 inches to +12 inches.

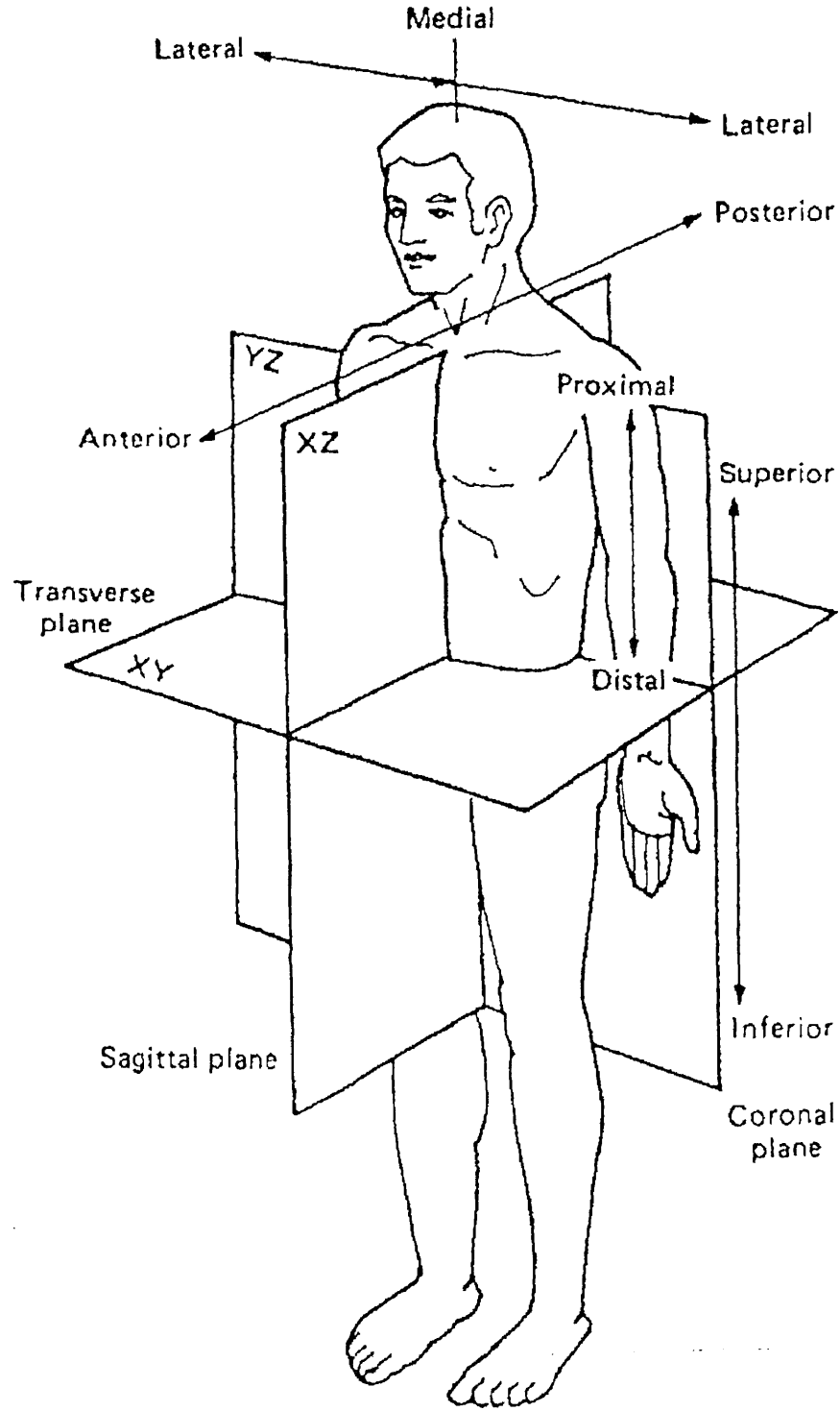

Figure 5.3 Reference Planes for Standing Operator.

5. The procedure begins with an initial set of coordinates representing a point in the feasible control panel. The first point to be examined is the extreme upper left corner position. The coordinates of this point are (-21, 18, 12).
6. To facilitate the solution on computer by numerical methods, a set of initial seed values for the joint angles are chosen. In this case, the values used will be the approximate midrange joint angles for each joint's range of motion (Figure 5.5). The seed values are (in radians): $\theta = 1.5$, $\phi = 1.3$, and $\delta = 1.1$.
7. The transformation equations for each coordinate and the constraint equations for each joint are entered as part of the problem. The computer program is then directed to find the solution (if possible) to within the level of precision (TOL) desired. The program then displays the solution vector (V) in both radians and degrees, and the ERR value (E) is checked to verify the results. Table 5.1 shows the output from computer solution of the ATM example problem.

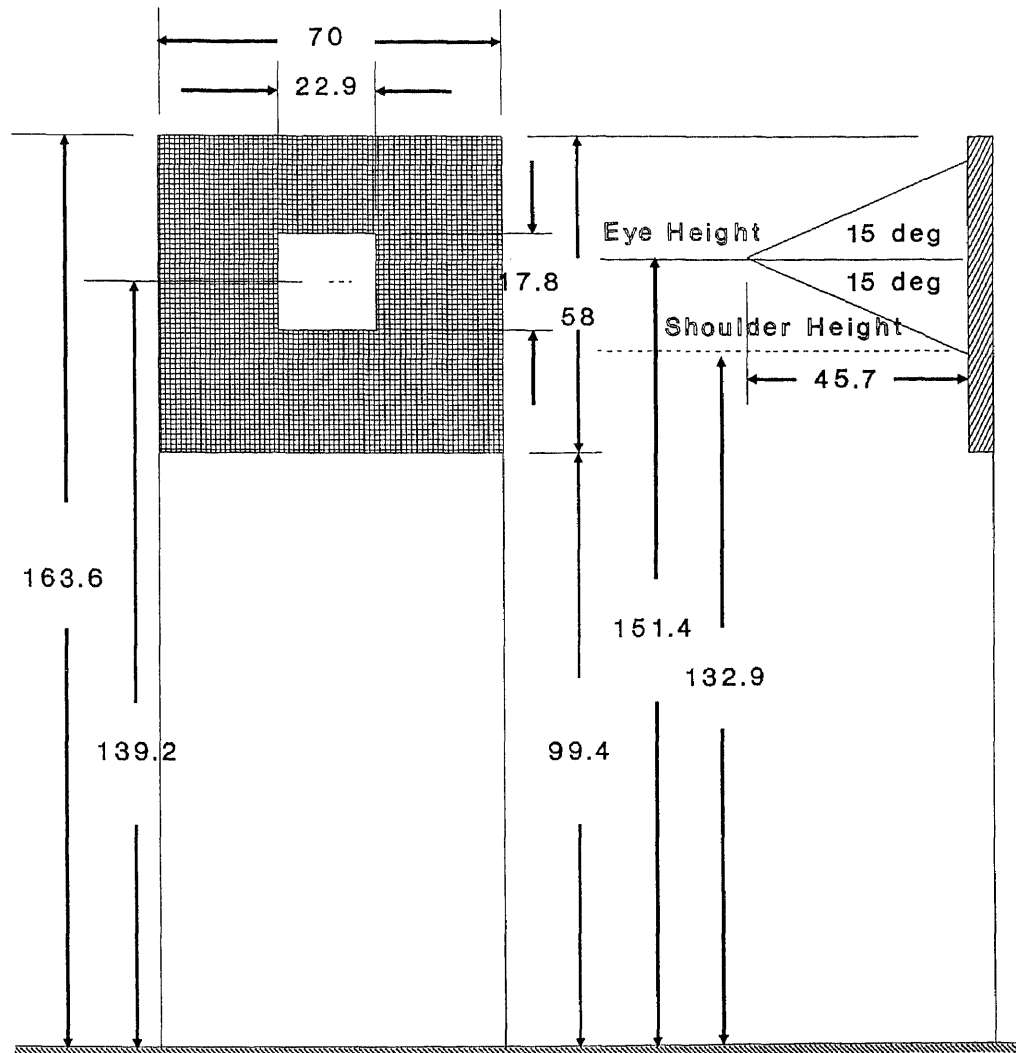

Figure 5.4 Control Panel Dimensions.

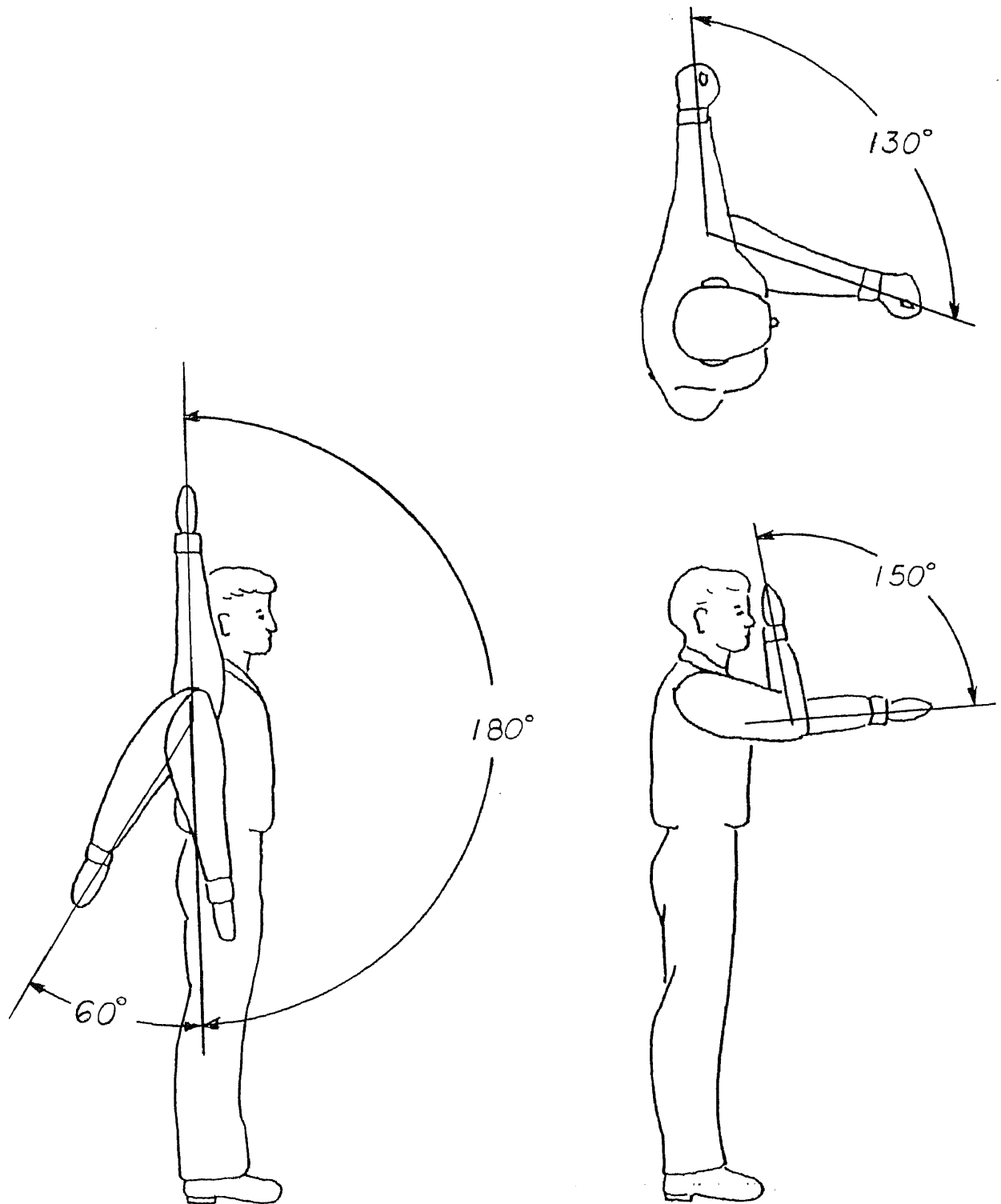

Figure 5.5 Range of Motion for Upper Body. Mean Values - Individual Ranges may Vary. (Adapted from Rodgers, et al., 1986).

Table 5.1 Computer Solution of Joint Angles.

Loc. No.	Spatial Coordinates			Joint Angles (radians)		
	x	y	z	THETA	PHI	DELTA
1	-21	18	12	2.277	0.399	0.519
2	-18	18	12	1.973	0.837	0.588
3	-15	18	12	1.764	1.096	0.675
4	-12	18	12	1.591	1.284	0.785
5	-9	18	12	1.446	1.423	0.927
6	-6	18	12	1.332	1.52	1.107
7	-3	18	12	1.257	1.578	1.326
8	0	18	12	1.231	1.597	1.571
9	3	18	12	1.257	1.578	1.816
10	6	18	12	1.332	1.52	2.034
11	-21	18	9	2.097	0.667	0.405
12	-18	18	9	1.917	0.91	0.442
13	-15	18	9	1.63	1.243	0.54
14	-12	18	9	1.446	1.423	0.644
15	-9	18	9	1.283	1.559	0.785
16	-6	18	9	1.147	1.655	0.983
17	-3	18	9	1.054	1.714	1.249
18	0	18	9	1.02	1.733	1.571
19	3	18	9	1.054	1.714	1.893
20	6	18	9	1.147	1.655	2.159
21	-21	18	6	1.993	0.81	0.278
22	-18	18	6	1.745	1.118	0.322
23	-15	18	6	1.53	1.344	0.381
24	-12	18	6	1.332	1.52	0.464
25	-9	18	6	1.147	1.655	0.588
26	-6	18	6	0.984	1.753	0.785
27	-3	18	6	0.861	1.812	1.107
28	0	18	6	0.813	1.832	1.571
29	3	18	6	0.861	1.812	2.034
30	6	18	6	0.984	1.753	2.356

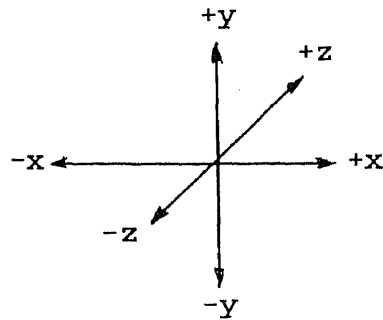
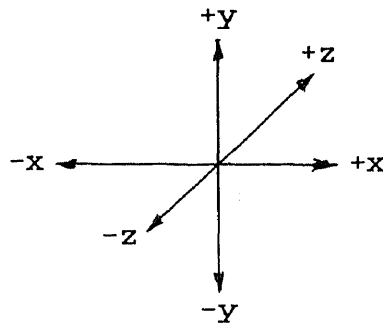

Table 5.1 (continued) Computer Solution of Joint Angles.

Loc. No.	Spatial Coordinates			Joint Angles (radians)		
	x	y	z	THETA	PHI	DELTA
31	-21	18	3	1.934	0.888	0.142
32	-18	18	3	1.688	1.181	0.165
33	-15	18	3	1.467	1.403	0.197
34	-12	18	3	1.257	1.578	0.245
35	-9	18	3	1.054	1.714	0.322
36	-6	18	3	0.861	1.812	0.464
37	-3	18	3	0.696	1.873	0.785
38	0	18	3	0.616	1.893	1.571
39	3	18	3	0.696	1.873	2.356
40	6	18	3	0.861	1.812	2.678
41	-21	18	0	1.915	0.912	0
42	-18	18	0	1.669	1.202	0
43	-15	18	0	1.446	1.423	0
44	-12	18	0	1.231	1.597	0
45	-9	18	0	1.02	1.733	0
46	-6	18	0	0.813	1.832	0
47	-3	18	0	0.616	1.893	0
48	0	18	0	0.436	1.914	1.1
49	3	18	0	0.616	1.893	3.142
50	6	18	0	0.813	1.832	3.142

Angles for remaining locations found by symmetry



5.3 Predictive Model of Endurance Time

Endurance is defined as the ability to continue to exert force over time. The amount of isometric work a person can accomplish is limited more by endurance than by strength. It is useful to be able to predict the endurance time of a particular activity without resorting to experimentation. If the task can be described in terms of body member configurations (joint angles and link lengths), an estimate of the endurance time in this configuration can be made.

5.3.1 Effect of Force on Endurance

It has been shown and there is widespread agreement that the human endurance time is a function of the amount of force required in a given activity. An activity which uses a high percentage of the member's maximum voluntary contraction (MVC) will have a very short endurance time, while a much less demanding task can have an almost indefinite endurance time. Kroemer (1970), Roebuck et al. (1975), and others provide data (Figure 5.6) which show the functional relationship between endurance time and the percentage of MVC applied. The experimental data indicates that the relationship of endurance time and strength appears to be exponential in nature.

An exponential regression equation is proposed as follows:

$$G_1 = 100 \exp(-t) + 20 \quad (5.2)$$

The validity of the regression equation can be verified by various methods. Plotting the experimental data and the expected values from regression (Figure 5.7), it becomes apparent that the curve of the experimental data (F) is a good fit to the regression curve (G) with $r^2 = 0.863$.

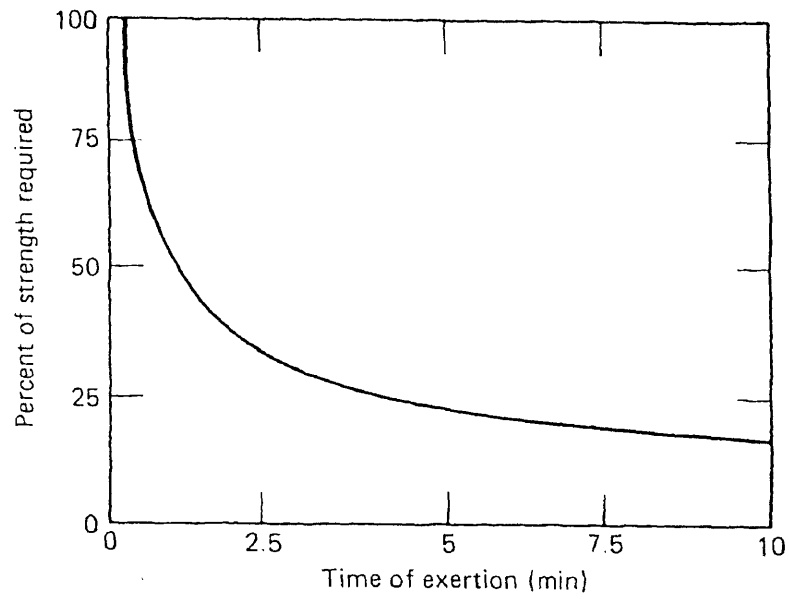

Figure 5.6 Endurance Time and Percentage of MVC (Adapted from Kroemer, 1970, and Roebuck et al., 1975).

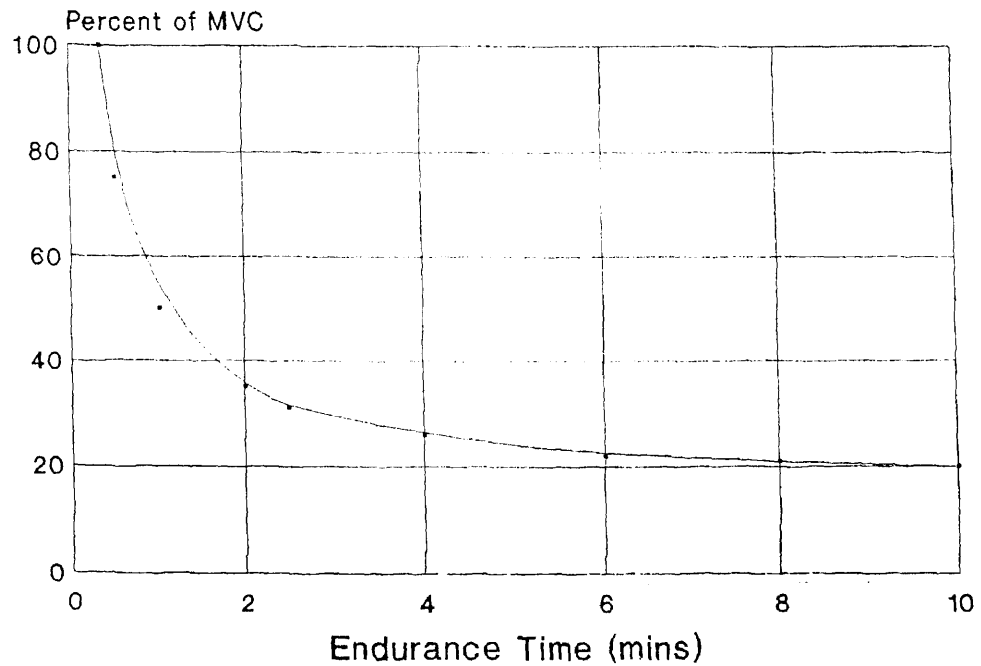

Figure 5.7 Endurance Time and Percentage of MVC - Plot of Regression Line

5.3.2 Effect of Elbow Angle on MVC Force

The change in isometric strength (F) compared to elbow angle (ϕ) has been determined experimentally (Knapik, Wright, and Mardsley, 1983). The data were collected on male subjects performing tasks requiring flexion and extension and show the percentage of MVC (P) at six elbow angles from 30 to 120 degrees. According to the graph (Figure 5.8), the maximum force is available with the elbow at an angle of 90 degrees, with a rapid falloff on either side of the curve.

5.3.3 Estimating Endurance Time

The endurance time for a given joint angle is predicted for a specific task by first determining the force requirements (F_R) demanded by the activity. In a simple example, assume that the workplace task dictates that the elbow is required to apply a force of $F_R = 8$ pounds. Next, the theoretical maximum force available (F_A) is determined from anthropometric data on the population under study. In this example, assume that $F_A = 40$ pounds MVC at the optimal angle. Then, the amount of force (A) actually available at the specified joint angle is adjusted to compensate for the reduction due to the angle effect according to the expression:

$$A = P \cdot F_A / 100 \quad (5.3)$$

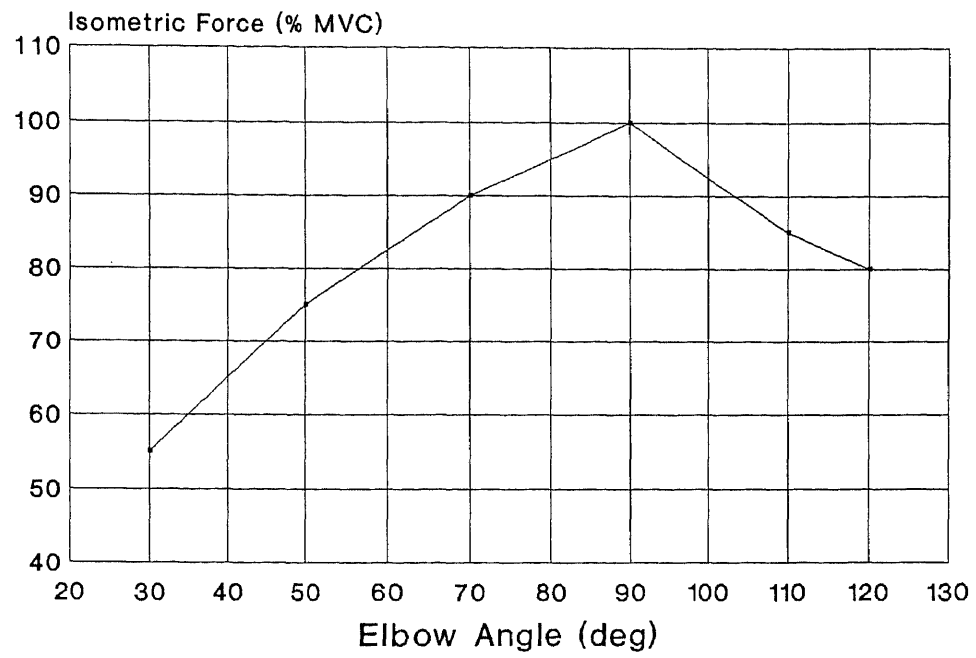

Figure 5.8 Graph of Isometric Force vs. Elbow Angle (Adapted from Knapik, Wright, and Mardsley, 1983).

Then, the required force (R) is expressed as a proportion to the actual available MVC by:

$$R = F_R / A \quad (5.4)$$

Finally, the regression equation (Equation 5.2) is rearranged to express the endurance time (t) as a function of the required force (R).

$$t = -\ln [R - (20/100)] \quad (5.5)$$

The approximate endurance times have been calculated for the six joint angles for which experimental data are available. Figures 5.9 and 5.10 show, respectively, the actual maximum available force (A), and the relative force as a percent of MVC, for selected joint angles. A predicted endurance time (T) is computed for the selected joint angles. Trials in which the required force (R) is a greater fraction of MVC are expected to have shorter endurance times.

The aforementioned technique is repeated for each feasible spatial location with its corresponding set of joint angles. The values for which experimental data are not available can be approximated by using linear interpolation between the available data points. In the general case a table can be constructed showing in each cell the predicted endurance time (T) for various force demand levels. In practice, however, the task requirements (e.g. 8 lbs.) will dictate which of the cell entries are to be used in a linear assignment problem.

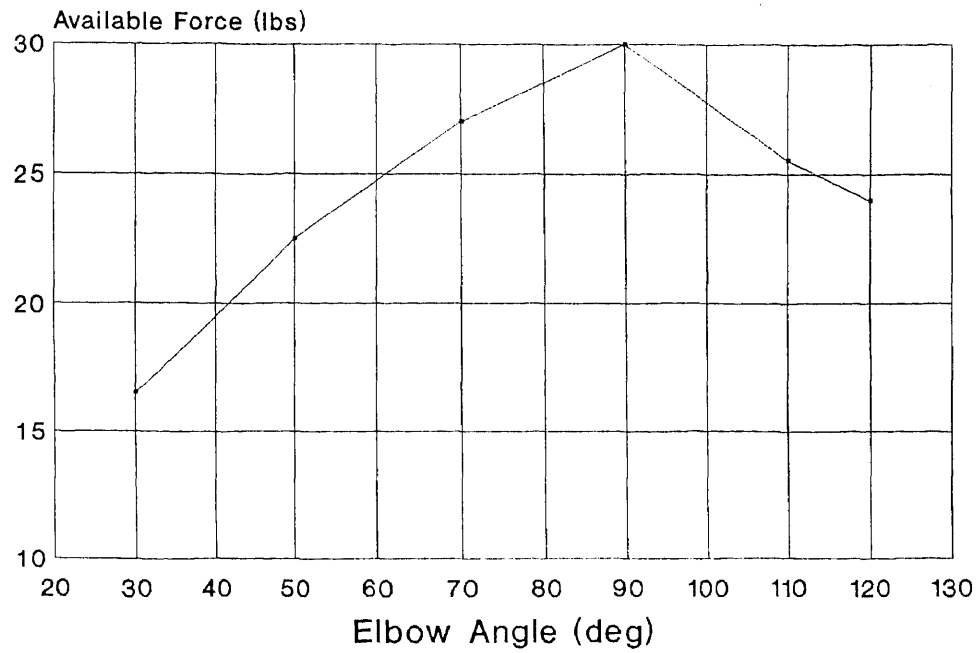

Figure 5.9 Available Force (A) at Selected Joint Angles (ϕ) (Adapted from Knapik, Wright, and Mardsley, 1983).

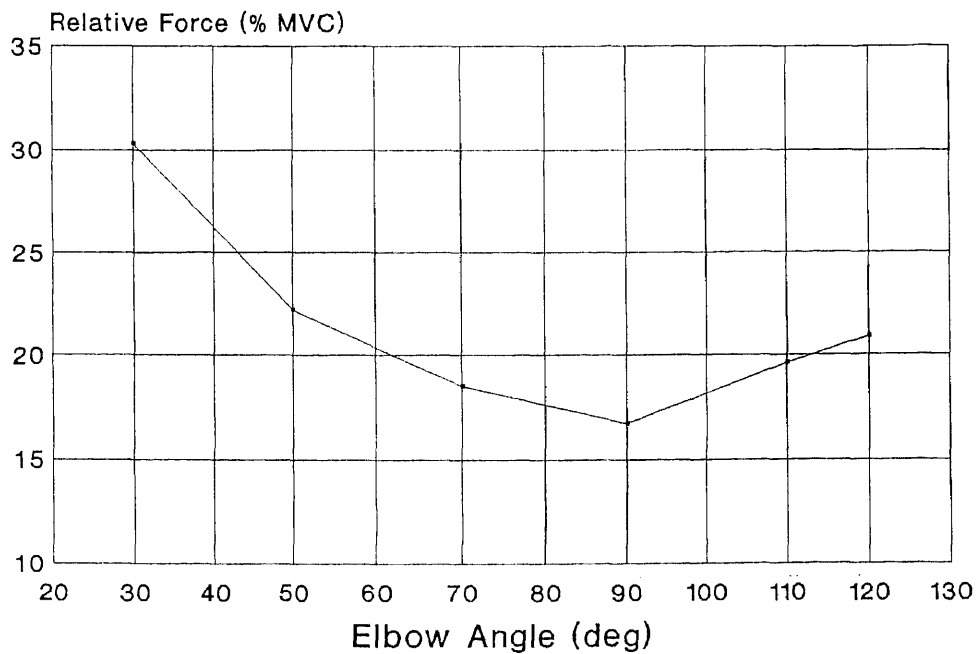

Figure 5.10 Relative Force (R) at Selected Joint Angles (ϕ) (Adapted from Knapik, Wright, and Mardsley, 1983).

We can define the fatigue rate as the rate in a given activity cycle at which the limit of endurance is approached. The fatigue rate value (F) is derived from the predicted endurance times for a given activity, and is computed by taking the reciprocal of endurance time. For each location on the ATM control panel, a predicted endurance time and fatigue rate for the given force demand level is given in Figure 5.11.

5.4 Linear Assignment Model Formulation

In order to minimize the total cost per ATM session (in terms of fatigue rate) the expected cost of assigning each node (control) to every feasible spatial location is calculated. The expected number of visits to a given node varies depending on the type of transaction and likelihood of multiple transactions per session. For Case III, the expected number of visits to each node is first estimated for each transaction type by examination of the system flowchart of Figure 5.12, multiple transaction probabilities, and transaction mix. The resulting probability distribution for multiple visits and the expected number of visits to each node (per ATM session) are given in Table 5.2.

Once the expected number of visits to each node for each type of transaction is determined, an assignment tableau is constructed which contains the cost of assigning each control to each location. The initial assignment matrix (Tableau 0) is given in Table 5.3.

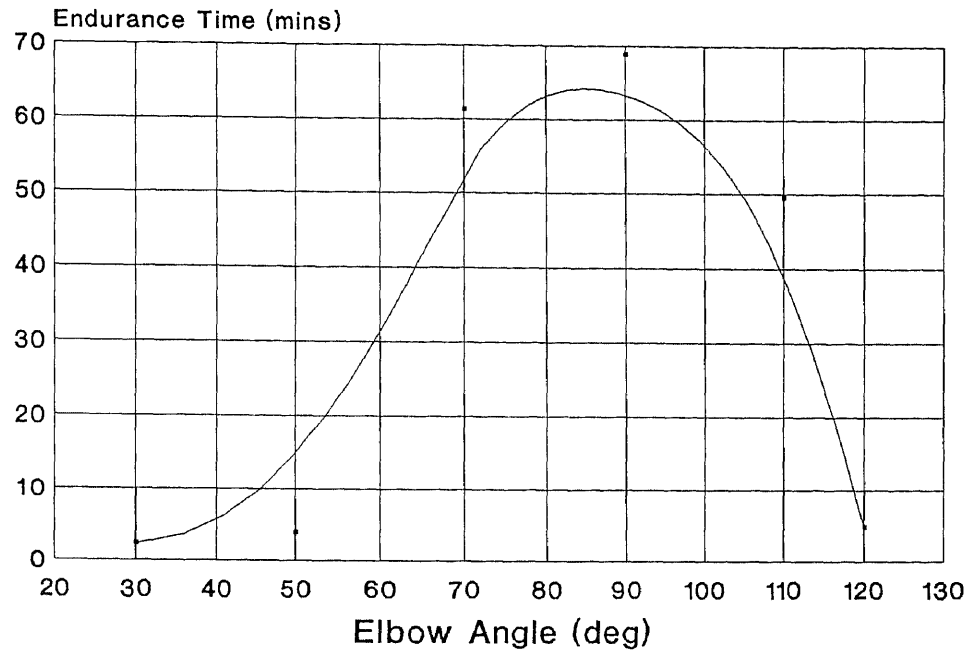

Figure 5.11 Predicted Endurance Times and Fatigue Rates Based on 5th Percentile Female and an 8-Pound Force Demand.

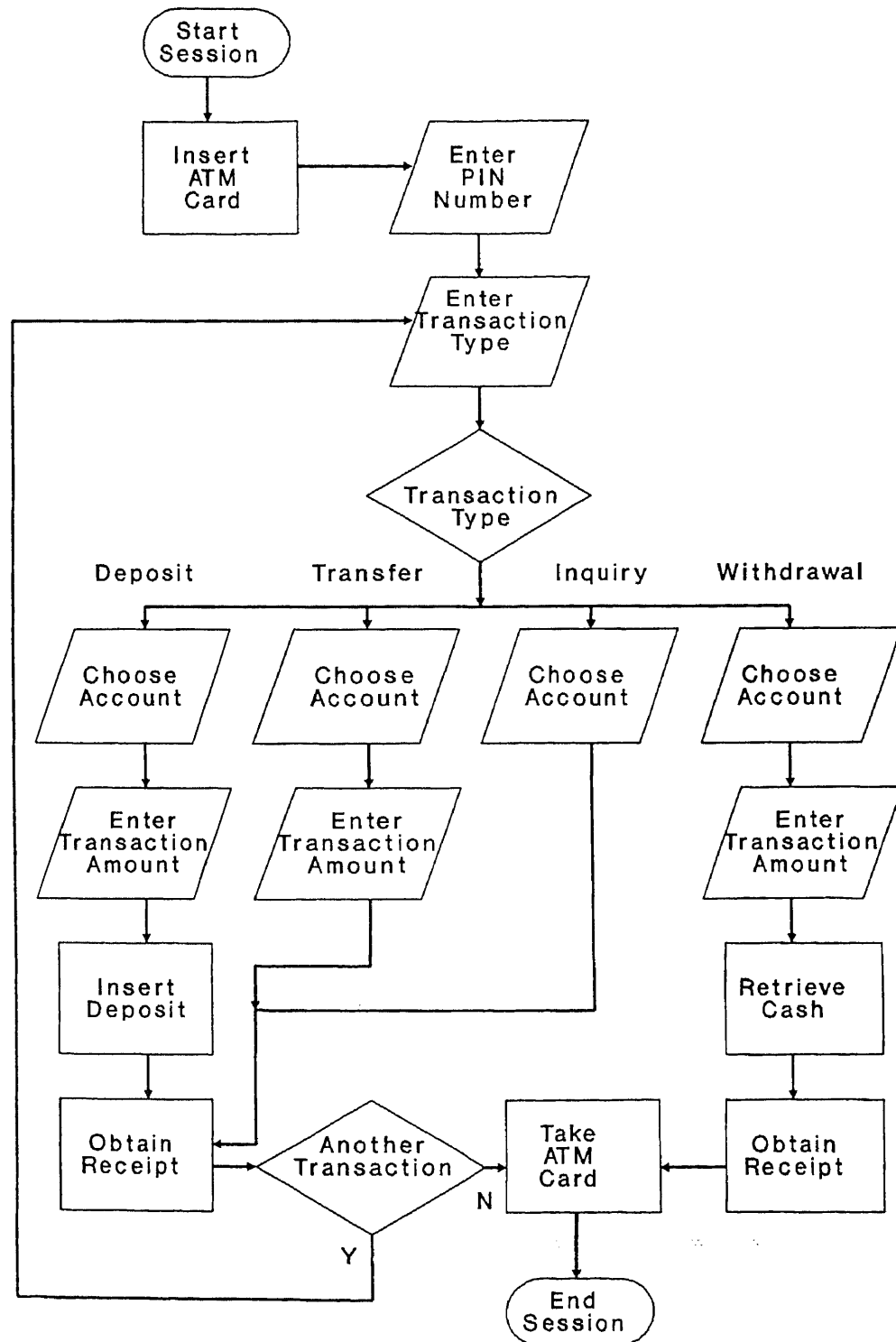

Figure 5.12 Forced Exit ATM Session Flowchart.

Table 5.2 Probability Distribution of Multiple Visits and Expected Visits to Each Node per ATM Session.

Node	n	Case I		Case II		Case III	
		P(n)	E(n)	P(n)	E(n)	P(n)	E(n)
Cardslot	0	0		0		0	
	1	1	1	0.9	1.1	0.9	1.1
	2	0		0.1		0.1	
Keypad	0	0		0		0	
	1	0.265	1.735	0.868	1.132	0.868	1.132
	2	0.735		0.132		0.132	
Keypad-1	0	1		0.256		0.256	
	1	0	0	0.646	0.842	0.646	0.842
	2	0		0.098		0.098	
Keypad-2	0	1		1		0.83	
	1	0	0	0	0	0.148	0.192
	2	0		0		0.022	
FunctKey	0	0		0		0	
	2	1	2	0.966	2.035	0.966	2.035
	3	0		0.033		0.033	
	4	0		0.001		0.001	
FunctKey-1	0	1		1		0.83	
	2	0	0	0	0	0.164	0.346
	3	0		0		0.006	
DeposSlot	0	0.87		0.87		0.87	
	1	0.13	0.13	0.13	0.13	0.108	0.152
	2	0		0		0.022	
RecptSlot	0	0		0		0	
	1	1	1	1	1	1	1
	2	0		0		0	
RecptSlot-1	0	1		1		0.83	
	1	0	0	0	0	0.17	0.17
	2	0		0		0	
CashDisp	0	0.455		0.455		0.455	
	1	0.545	0.545	0.545	0.545	0.545	0.545
	2	0		0		0	

Table 5.3 Location Parameters and Assignment Cost Matrix for Case III.

Location Parameters			Assignment Cost (Cij)					
			i = 1	i = 2	i = 3	i = 4	i = 5	i = 6
Loc. j	Endur Time	Fatigue Rate	Card Slot	Key Pad	Functn Key	Deposit Slot	Receipt Slot	Cash Disp
1	1.28	0.781	0.859	1.692	1.891	0.119	0.914	0.426
2	2.6	0.385	0.423	0.833	0.931	0.058	0.450	0.210
3	3.31	0.302	0.332	0.654	0.731	0.046	0.353	0.165
4	4.02	0.249	0.274	0.539	0.602	0.038	0.291	0.136
5	4.73	0.211	0.233	0.458	0.512	0.032	0.247	0.115
6	5.82	0.172	0.189	0.372	0.416	0.026	0.201	0.094
7	7.38	0.136	0.149	0.293	0.328	0.021	0.159	0.074
8	6.08	0.164	0.181	0.356	0.398	0.025	0.192	0.090
9	7.38	0.136	0.149	0.293	0.328	0.021	0.159	0.074
10	5.82	0.172	0.189	0.372	0.416	0.026	0.201	0.094
11	2.15	0.465	0.512	1.007	1.126	0.071	0.544	0.253
12	2.8	0.357	0.393	0.774	0.865	0.054	0.418	0.195
13	3.88	0.258	0.284	0.558	0.624	0.039	0.302	0.140
14	4.73	0.211	0.233	0.458	0.512	0.032	0.247	0.115
15	7.3	0.137	0.151	0.297	0.332	0.021	0.160	0.075
16	4.89	0.204	0.225	0.443	0.495	0.031	0.239	0.111
17	4.33	0.231	0.254	0.500	0.559	0.035	0.270	0.126
18	4.2	0.238	0.262	0.516	0.576	0.036	0.279	0.130
19	4.33	0.231	0.254	0.500	0.559	0.035	0.270	0.126
20	4.89	0.204	0.225	0.443	0.495	0.031	0.239	0.111
21	2.52	0.397	0.437	0.860	0.961	0.060	0.464	0.216
22	3.39	0.295	0.324	0.639	0.714	0.045	0.345	0.161
23	4.28	0.234	0.257	0.506	0.566	0.036	0.273	0.127
24	5.82	0.172	0.189	0.372	0.416	0.026	0.201	0.094
25	4.89	0.204	0.225	0.443	0.495	0.031	0.239	0.111
26	4.08	0.245	0.270	0.531	0.593	0.037	0.287	0.134
27	3.77	0.265	0.292	0.575	0.642	0.040	0.310	0.145
28	3.68	0.272	0.299	0.589	0.658	0.041	0.318	0.148
29	3.77	0.265	0.292	0.575	0.642	0.040	0.310	0.145
30	4.08	0.245	0.270	0.531	0.593	0.037	0.287	0.134

Notes

1. Fatigue Rate = Reciprocal of Endurance Time
2. $C_{ij} = (\text{Fatigue Rate at Location } j) \times (\text{Frequency of Use of Control } i)$

Table 5.3 (Continued) Location Parameters and Assignment Cost Matrix for Case III.

Location Parameters			Assignment Cost (Cij)					
			i = 1	i = 2	i = 3	i = 4	i = 5	i = 6
Loc. j	Endur Time	Fatigue Rate	Card Slot	Key Pad	Functn Key	Deposit Slot	Receipt Slot	Cash Disp
31	2.74	0.365	0.401	0.791	0.884	0.055	0.427	0.199
32	3.63	0.275	0.303	0.597	0.667	0.042	0.322	0.150
33	4.6	0.217	0.239	0.471	0.526	0.033	0.254	0.118
34	7.38	0.136	0.149	0.293	0.328	0.021	0.159	0.074
35	4.33	0.231	0.254	0.500	0.559	0.035	0.270	0.126
36	3.77	0.265	0.292	0.575	0.642	0.040	0.310	0.145
37	3.51	0.285	0.313	0.617	0.690	0.043	0.333	0.155
38	3.44	0.291	0.320	0.630	0.704	0.044	0.340	0.158
39	3.23	0.310	0.341	0.671	0.750	0.047	0.362	0.169
40	3.77	0.265	0.292	0.575	0.642	0.040	0.310	0.145
41	2.8	0.357	0.393	0.774	0.865	0.054	0.418	0.195
42	3.72	0.269	0.296	0.582	0.651	0.041	0.315	0.147
43	4.73	0.211	0.233	0.458	0.512	0.032	0.247	0.115
44	6.08	0.164	0.181	0.356	0.398	0.025	0.192	0.090
45	4.2	0.238	0.262	0.516	0.576	0.036	0.279	0.130
46	3.68	0.272	0.299	0.589	0.658	0.041	0.318	0.148
47	3.44	0.291	0.320	0.630	0.704	0.044	0.340	0.158
48	3.36	0.298	0.327	0.645	0.721	0.045	0.348	0.162
49	3.44	0.291	0.320	0.630	0.704	0.044	0.340	0.158
50	3.68	0.272	0.299	0.589	0.658	0.041	0.318	0.148

Notes

1. Fatigue Rate = Reciprocal of Endurance Time
2. $C_{ij} = (\text{Fatigue Rate at Location } j) \times (\text{Frequency of Use of Control } i)$

5.5 Solution of Assignment Model

The computer solution of the assignment model is found using an adaptation of the Hungarian algorithm (as outlined in Section 3.11), implemented in the IBM PC software program ASSIGN1. The data from the assignment cost matrix (Tableau 0) is entered into the program, and after several iterations an optimal tableau is found. The results of the computation can be found in the Appendix.

5.6 Layout Recommendations

An analysis of the results yields multiple optimal and near-optimal solutions to the minimization assignment problem. From these solution sets several layouts (Figures 5.13 through 5.16) can be described in which the total fatigue rates will be minimal. The choice of which (if any) solution should be implemented will be based upon heuristics and other considerations. In this case study, the selected layout is as shown in Figure 5.17. The rationale for this selection is that the keypad and function keys are ideally located near to the eye level and adjacent to the CRT display.

1	2	3	4	5	6	7 Key Pad	8 Rec Slot	9 Card Slot	10
11	12	13	14	15 Funct Key	16	17	18	19	20
21	22	23	24	25	26	27	28	29	30
31	32	33	34 Cash Disp	35	36	37	38	39	40
41	42	43	44 Dep Slot	45	46	47	48	49	50

Total Cost of Assignment: 1.14

Figure 5.13 Layout for ATM Control Panel #1.

1	2	3	4	5	6	7 Key Pad	8 Funct Key	9 Rec Slot	10
11	12	13	14	15 Card Slot	16	17	18	19	20
21	22	23	24	25	26	27	28	29	30
31	32	33	34 Cash Disp	35	36	37	38	39	40
41	42	43	44 Dep Slot	45	46	47	48	49	50

Total Cost of Assignment: 1.14

Figure 5.14 Layout for ATM Control Panel #2.

1	2	3	4	5	6	7 Funct Key	8 Rec Slot	9 Card Slot	10
11	12	13	14	15 Key Pad	16	17	18	19	20
21	22	23	24	25	26	27	28	29	30
31	32	33	34 Cash Disp	35	36	37	38	39	40
41	42	43	44 Dep Slot	45	46	47	48	49	50

Total Cost of Assignment: 1.14

Figure 5.15 Layout for ATM Control Panel #3.

1	2	3	4	5	6	7 Key Pad	8 Rec Slot	9 Card Slot	10
11	12	13	DISPLAY			17 Funct Key	18	19	20
21	22	23				27	28	29	30
31	32	33	34 Cash Slot	35	36	37	38	39	40
41	42	43	44 Dep Slot	45	46	47	48	49	50

Total Cost of Assignment: 1.367

Figure 5.16 Layout for ATM Control Panel #4.

1	2	3	4	5	6	7	8	9	10
						Rec Slot		Card Slot	
11	12	13	14	DISPLAY			18	19	20
									Funct Key
21	22	23	24				28	29	30
31	32	33	34	35	36	37	38	39	40
			Dep Slot						Cash Disp
41	42	43	44	45	46	47	48	49	50

Total Cost of Assignment: 1.55

Figure 5.17 Preferred Layout for ATM Control Panel.

5.7 Software Ergonomics

5.7.1 Video Screen Layout

Mental workload requirements for a particular task are directly related to the design of the human-machine interface. With a poor interface design, the point of information overload may possibly be approached for some members of the user base. Human information processing capabilities are often unnecessarily overtaxed by presenting a user with too much, unneeded, or confusing information. In contrast, efficient design will substantively improve performance for the entire user population.

5.7.2 Design Simplification

One of the fundamental tenets of effective screen design is simplicity. Providing the user with an interface that presents the required information and obtains the desired response objectives is the responsibility of programmers. Just as nature abhors a vacuum, programmers seem to abhor presenting blank space on a display screen. Given a screen capable of displaying many characters, the tendency of programmers is to fill it just because it is there (Morland, 1983). This is exhibited in several ATM system dialog screens. It has been shown that most transactions will proceed faster if the amount of (superfluous) information displayed on the screen is minimized. (Morland, 1983).

5.7.3 Social Amenities

Computers frequently are met by the public with resistance, apprehension or even fear. Programmers, sensitive to this, often overcompensate by liberally including social amenities in their systems. There is a tendency to include phrases such as "PLEASE," "IF YOU WANT," and "DO YOU WISH" in dialog screens. Although it is important that computers appear not to be rude, it is recommended that these social amenity phrases be systematically eliminated in the interest of improving clarity (Morland, 1983).

Pseudopersonal dialogs are also commonly found in ATM as well as other software designs. It is recommended that designers should not attempt to be too friendly, so that displaying "GOOD AFTERNOON, JOHN DOE" - which serves no useful purpose other than exhibiting that the time of day and identity of the user is known to the system - and similar phrases should be avoided.

5.7.4 Implicit Input Requests

Systems designed for use by the general public should be designed to be as explicit as necessary about what the user should do at each stage of the transaction. However, on the screens specifically requesting input, the fact that the computer is requesting input can be made implicit instead of explicit without introducing adverse effects. For example, the relatively verbose messages:

"PLEASE SELECT THE TYPE OF TRANSACTION THAT YOU WISH,"
and

"WHAT IS THE AMOUNT OF YOUR DESIRED TRANSACTION?"
can be replaced by:

"TYPE OF TRANSACTION:"

and

"AMOUNT."

The result can be a less cluttered screen with improved operator performance.

5.7.5 Entry Error Handling and Logging

Data entry errors can never be eliminated. The goal instead is to minimize the consequences of user errors that occur. The ability to undo a mistake is a desirable feature. Users should be given the opportunity to self-correct their keyboarding errors with one or more clearly labeled keys for: cursor back, backspace, redo, or cancel. The error control strategy must, wherever possible, give clear indication of an error as soon as it is detected, and preferably recommend a suggested remedy. Automatic error logging is essential in accurate detection of user errors made in performing various functions and their types, and the collection of error statistics will aid in the evaluation of operator skill levels and in the diagnosis of human-machine interface problems.

5.7.6 Global and Local Patterns

From the historical distribution of ATM transaction types, it is apparent that some transactions occur with greater frequency than others. However, a particular institution may find from study of historical records of ATM sessions that their transaction mix may differ from the industry standards. Certain transaction types such as cash deposit to checking account may in some cases be found to occur more often than cash withdrawal from checking. System defaults should therefore be adjusted to reflect the transaction pattern in the local area specifically under study.

5.7.7 System Default Strategies

System default entries represent an attempt by the software system designers to anticipate the answers a user will give to some or all of the system's queries. A system may have (at one extreme) no defaults at all, in which the user must enter all data required; and (at the other extreme) "entry-by-exception", in which the system supplies all of its own answers and the user enters data only when on-screen defaults are incomplete or inaccurate (Martin, 1973).

Default entries are usually established by the system designer or development team when the system is created.

Morland (1983) suggests that default values can be assigned based on three factors:

1. How universal are the default responses?
2. How stable are they?
3. How context dependent are they?

Theoretically, a large number of separate default sets can be defined: systemwide, site-dependent, group-dependent, or even individual user.

5.7.8 Response-Based Defaults

Although it is recognized that defaults should be held constant as much as possible, Morland (1983) advocates the evolution of default values on the basis of a continuous statistical analysis of user responses. The responses for the entire user base can be compiled and interpreted by either the host computer or satellite processors. The system would start with an initial default set. After observing a sufficient number of user responses, the default set would be revised when a more statistically significant response pattern is found. Several important control parameters must be established, such as the threshold frequency of a given response required to trigger a change in default (Morland, 1983).

5.7.9 Evolutionary Interface

An evolutionary interface can be designed for the ATM in which the manual analysis and assignment of user defaults completely unnecessary. An artificially intelligent multilevel system could continually monitor and collect data

on the user's pattern of accesses to the system, and alter the interface presentation sequences according to a set of established rules.

For example, consider a user who most frequently uses an ATM for cash withdrawals of \$100.00 from his checking, and never performs transfers between accounts. Such a user could eventually have his top level menu screen evolve from the system default menu (Figure 5.19) to the menu shown in Figure 5.20. At any time the user could, if desired, access any other non-displayed options by requesting "other" from the menu. If menu option "other" is selected and some other type of transaction is chosen a significant number of times, then the user's default menu would adapt accordingly.

5.7.10 Multilevel ATM Interface Design

ATM Systems should be designed to accommodate users with different experience levels within the user population. This strategy will permit a wide variety of users to use the system efficiently. Once a user has gained access to the system, by inserting his card and entering a valid personal identification number (PIN), his identity is known with absolute certainty.

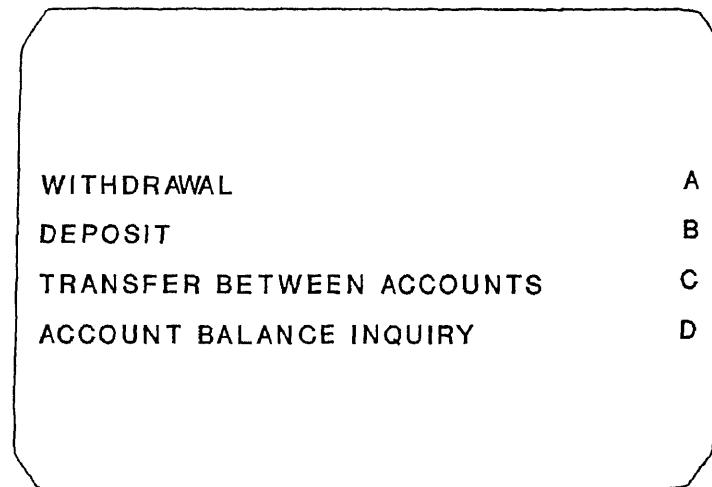

A rectangular menu box with rounded corners containing four options, each with a corresponding letter to its right.

WITHDRAWAL	A
DEPOSIT	B
TRANSFER BETWEEN ACCOUNTS	C
ACCOUNT BALANCE INQUIRY	D

Figure 5.18 Default ATM Top Level Menu Provided to All Users.

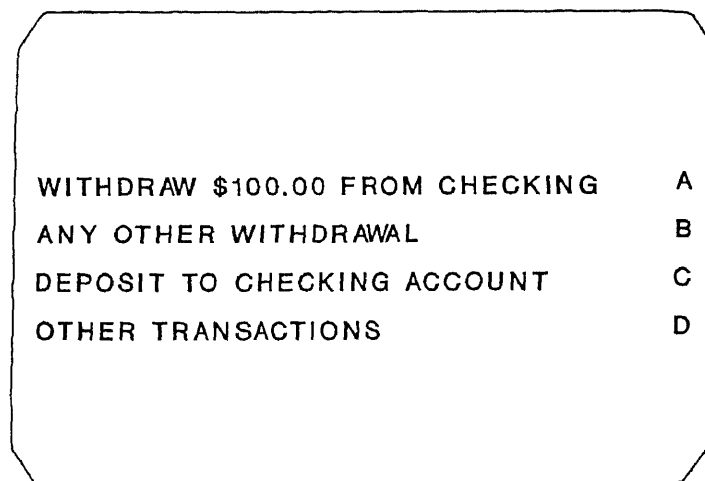

A rectangular menu box with rounded corners containing four specific options, each with a corresponding letter to its right.

WITHDRAW \$100.00 FROM CHECKING	A
ANY OTHER WITHDRAWAL	B
DEPOSIT TO CHECKING ACCOUNT	C
OTHER TRANSACTIONS	D

Figure 5.19 Individualized ATM Top Level Menu Based on User Transaction Patterns.

With the system default, novice users are given the standard user interface, using the techniques referred to as numbers 9 and 11 by Martin (1973), and generous help capabilities. Users identified as more advanced can be offered more condensed screens, combined screen cues, and abbreviated input fields (such as in techniques 12 through 15). Expert users could be provided with even more advanced features, typeahead, or even command language (techniques 4, 5, and 16 through 20).

For example, consider the common input sequence of entering a PIN number, such as # 5151, then selecting to make a cash withdrawal from the checking account in the amount of 100 dollars. The transaction sequence is as follows:

Enter PIN number	5 1 5 1 <ENTER>
(wait for validation and menu display)	
Choose Transaction Type	1 <ENTER>
(wait for next menu)	
Choose Account	1 <ENTER>
(wait for next menu)	
Enter Amount (\$100.00)	10000 <ENTER>
(transaction is completed)	

The normal ATM transaction sequence to achieve this result requires fifteen keystrokes, three pauses, and three queries for additional input.

A command line interface could be set up for more advanced users to perform the same transaction more quickly and efficiently. In constructing the command line, the first four digits represents the PIN number, the fifth digit is the transaction type (1 = cash withdrawal from checking), and 100 is the amount of \$100.00. The command line transaction sequence is as follows:

```
Enter PIN number          5 1 5 1 1 1 0 0 <ENTER>
                           (transaction is completed)
```

A user employing the command line interface accomplishes the same transaction in only nine keystrokes, with no pauses or queries for additional input.

The command line entry system would process this input from the recognized expert user and, once validated, handle the entire transaction faster and without the need for additional dialogs.

The approach of altering the presentation or merging several screens into one, while somewhat more difficult to implement, can be worthwhile if the distribution of skill levels within the user base is characterized as "bathtub-shaped". For example, a user population following this distribution contains relatively few average users, and a large number of novice and advanced users. It is very likely that the distribution of ATM user skill levels falls into this category, since many users can learn and develop proficiency quickly, while a large number apparently do not. As a result, many transactions are performed by persons at each end of the proficiency spectrum.

The user's "expert rating" can be assigned a numerical value according to his ATM performance over time, possibly based on time per screen, time per transaction, user response time, total errors, number of canceled transactions, or keying signature (Gilb, 1977).

A great deal of information can be determined by analyzing the user's individual keying pattern. Weinberg (1965) discovered that by timing keystrokes and combinations of keystrokes, a timing signature can be found to indicate the proficiency and possibly even the identity of a user. In addition, changes in keying times during input (blips) can be used to discover errors or poorly designed procedures (Gilb, 1977).

The logic of a proposed quasi-intelligent system is as shown in the flowchart in Figure 5.20. For example, a user who typically completes an ATM session quickly and with few errors could have his proficiency rating automatically revised to better utilize his demonstrated ability, while a user who makes many errors or often sees the "need more time?" prompt could have his rating modified to give him a more helpful interface. Changes in the user's proficiency levels (either up or down) would be detected by the system and the interface modified accordingly. With automatic logging, a self-maintaining system could be devised which would be completely transparent to the user and therefore require no intervention from either the user or the system operator.

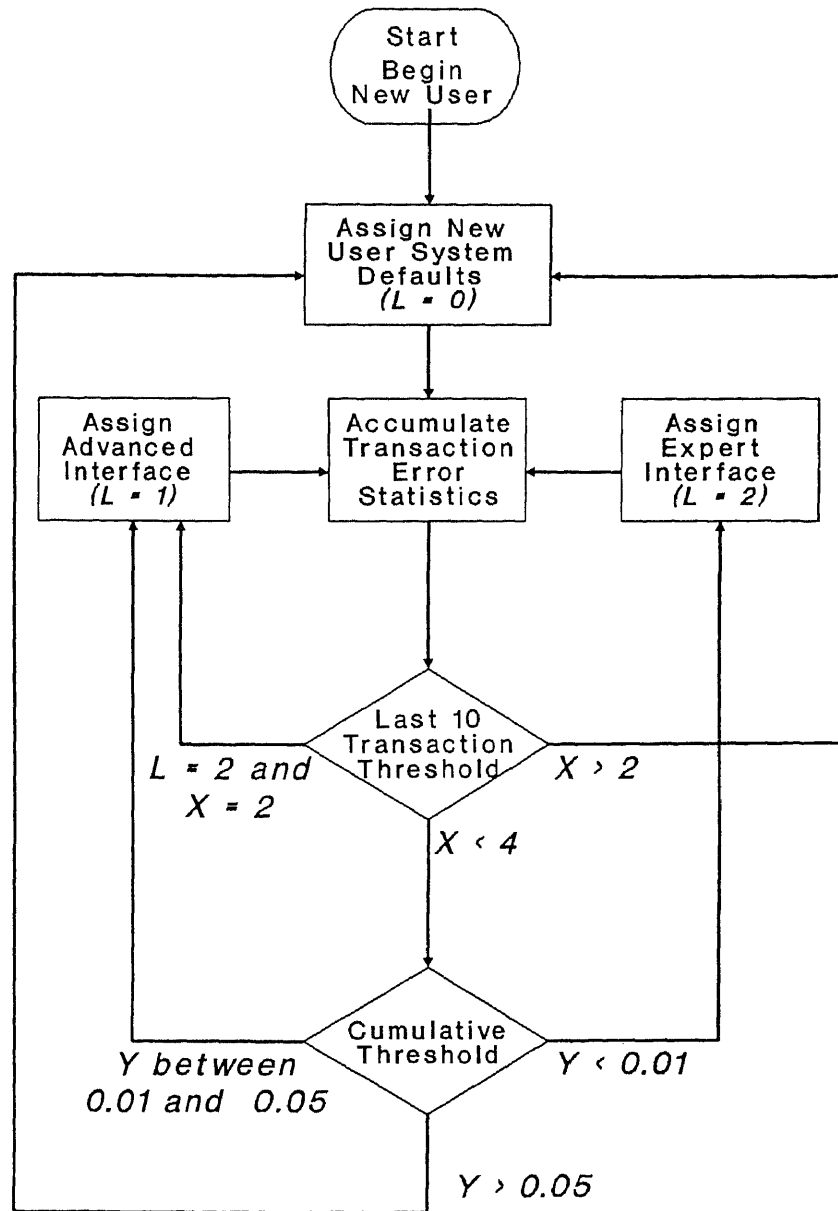

Notes

1. X = Number of errors in previous 10 transactions
2. Y = Cumulative errors divided by total transactions

Figure 5.20 Flowchart for an Adaptive User Proficiency System.

CHAPTER 6 CONCLUSIONS AND RECOMMENDATIONS

In solving the ATM layout problem this thesis utilized methods which yielded satisfactory solutions from the ergonomic point of view. The resulting system designs should prove workable in practice as long as the underlying assumptions made in this thesis are valid. The concepts and methods employed are believed to be valid when applied not only to the ATM problem, but to similar problems in human-machine interface design in which position costs dominate and motion costs are of minor importance.

The methods of determining joint configurations from points in space are well established, and most of the underlying assumptions made in the endurance model formulations are based on recognized principles of ergonomics and biomechanics. The heuristic design guidelines provided by the human factors profession are helpful in specifying and designing an ergonomic workplace.

The specific layout, although believed to be optimal, may in some cases be found infeasible for reasons of physical or mechanical impracticality. For example, the internal dimensions behind the panel of a cash dispensing mechanism may prohibit its installation in a given location. The detailed information needed to ascertain this and incorporate this situation into the model was unobtainable. If necessary, however, the model could be reformulated the problem with the physical limitation constraints and the problem solving procedure repeated.

Some basic simplifying assumptions are made in the formulation of cost coefficients. The first is that the optimization of the elbow joint is the most critical in determining endurance times and fatigue rates. The justification for this assumption is based on the relative muscle sizes of the limbs involved in upper body work activities. Future research may test the validity of this assumption, and if it is found that other biomechanical effects are significant, other cost coefficients could be developed accordingly.

Other assumptions are that individual body parts are independent of each other, that the endurance times for each body element can be separately determined, and that the fatigue-inducing effort affecting one part does not necessarily affect the other parts of the body. These assumptions may also be tested by experimentation. Tests of human endurance in simulated workplace conditions can be developed that will show if the independence assumption is valid. It is recommended that any further studies in this area should include the additional research and experimentation to verify the assumptions stated herein.

The ergonomic design guidelines employed for the physical workplace provide an ergonomically efficient standing workstation for the design population (5th percentile female) and an ergonomically acceptable workstation for the majority of the anticipated user base.

The combination of kinematic analysis and prediction of human fatigue rates may, when combined with the appropriate anthropometric data, be used to develop quantitative reach envelopes for general populations, a segment of the

population, or even individuals. Also, quantitative assessments of existing layouts and comparisons between competing design proposals can be made.

The implementation of adaptive human-machine interfaces is strongly recommended. Instead of relying on fixed position controls, a designer, given the design population's anthropometric, biomechanical, movement, mental processing and perceptual capabilities, can develop an adaptive interface which responds to the user's requirements. The control panel layouts can be efficiently designed by software programs such as the expert systems currently used to design machine and motor control panels (Blickley, 1988).

In the ideal case, a control panel could be comprised of an array of touch sensitive screens, such as is found in power plant simulators (Reason, 1988), or in the "glass cockpits" of new generation airliners such as the Boeing 777 (Scott, 1991). With such a system an optimal custom interface can - at least theoretically - be provided to each user. Control and display types, sizes, locations, and complexities can be determined by system software, based on the situation at hand and the requirements of the user, so as to maximize the overall ergonomic efficiency of the system.

BIBLIOGRAPHY

- Abdel-Malek, L. L. and Z. Li. "The Application of Inverse Kinematics in the Optimum Sequencing of Robot Tasks." *International Journal of Production Research*. 28(1): 75-90. 1990.
- Alden, D. G., R. W. Daniels and A. T. Kanarick. "Keyboard Design and Operation: A Review of the Major Issues." *Human Factors*. 14: 275-293. 1972.
- Ambrosino, G. "Adaptive Tracking Control of Industrial Robots." *Journal of Dynamic Systems Measurement and Control*. 110: 215-220. September 1988.
- Anderson, R. B. *MathCAD User's Manual Student Edition Version 2.0*. Reading, MA: Addison-Wesley, 1989.
- Asfour, S. S., M. Tritar, and A. M. Genaidy. "Endurance Time and Physiological Responses to Prolonged Arm Lifting." *Ergonomics*. 34(3): 335-342. 1991.
- Avis, D. "A Survey of Heuristics for the Weighted Matching Problem." *Networks*. 13: 475-493. 1983.
- Avis, D. and C. W. Lai. "The Probabilistic Analysis of a Heuristic for the Assignment Problem." *SIAM Journal on Computing*. 17(4): 732-741. August 1988.
- Banks, W. W. and M. P. Boone. "Method For Quantifying Control Accessibility." *Human Factors*. 23: 299-303. June 1981.
- Benhabib, B. "Optimal Continuous Path Planning for Seven Degree of Freedom Robots." *Journal of Engineering Industry*. 108: 213-218. August 1986.
- Bhat, U. N. *Elements of Applied Stochastic Processes*, 2nd ed. New York: John Wiley and Sons, 1984.
- Bishop, A. "Membrane Keyboards Adopting Raised Keys." *Electronics*. 44. August 14, 1980.
- Blickley, G. J. "Control Panel Design Made Easy with Software." *Control Engineering*. 35: 68-70. June 1988.
- Bonney, M. C. and R. W. Williams. "CAPABLE: A Computer Program to Layout Controls and Panels." *Ergonomics*. 20: 297-316. 1977.
- Caldwell, L. S. "Body Stabilization and the Strength of Arm Extension." *Human Factors*. 4(3):125-130. March 1962.
- _____. "The Load-Endurance Relationship for a Static Manual Response." *Human Factors*. 6(1):71-79. January 1964.

- _____. "Body Position and the Strength and Endurance of Manual Pull." *Human Factors*. 6(7):479-484. July 1964.
- Chapanis, A. *Research Techniques in Human Engineering*. Baltimore: Johns Hopkins Press, 1953.
- Chaffin, D. B. "A Computerized Biomechanical Model - Development of and Use in Studying Gross Body Actions." *Journal of Biomechanics*. 2: 429-441. 1969.
- Chaffin, D. B. and M. Erig. "Three-Dimensional Biomechanical Static Strength Prediction Model Sensitivity to Postural and Anthropometric Inaccuracies." *IIE Transactions*. 23: 215-227. September 1991.
- Chaffin, D. B., A. Freivalds and S. M. Evans. "On the Validity of an Isometric Biomechanical of Worker Strengths." *IIE Transactions*. 19: 280-288. September, 1987.
- Charnes, A. and W. W. Cooper. *Management Models and Industrial Applications of Linear Programming*. New York: John Wiley and Sons, 1961.
- Cockton, G. "Interaction Ergonomics, Control and Separation: Open Problems in User Interface Management." *Information Software Technology*. 29: 176-191. May 1987.
- Cramer, H. *The Elements of Probability Theory and Its Applications*. New York: John Wiley and Sons, 1955.
- Cullinane, T. P. "Minimizing Cost and Effort in Performing a Link Analysis." *Human Factors* 19: 151-156. 1977.
- Deiningner, R. L. "Human Factors Engineering Studies of the Design and Use of Push-Button Telephone Sets." *Bell Systems Technical Journal*, 39: 995-1012. July 1960.
- Denavit, J. and R. S. Hartenberg. "A Kinematic Notation for Lower-Pair Mechanisms Based on Matrices." *Journal of Applied Mechanics*. 215-221. June 1955.
- Downing, J. V. and M. S. Sanders. "Effects of Panel Arrangement and Locus of Attention on Performance." *Human Factors*. 29: 551-62. October 1987.
- Drake, A. W. *Fundamentals of Applied Probability Theory*, McGraw-Hill Series in Probability and Statistics. New York: McGraw-Hill, 1967.
- Drezner, Z. "DISCON: A New Method for the Layout Problem." *Operations Research*. 28: 1375-1384. 1980.
- Erikson, W. J. and O. P. Hall, Jr. *Computer Models for Management Science*, 2nd ed. Reading, MA: Addison-Wesley, 1986.

- Francis, R. L. and J. A. White. *Facility Layout and Location: An Analytical Approach*. Englewood Cliffs, NJ: Prentice-Hall, 1974.
- Freund, L. E. and T. L. Sadosky. "Linear Programming Applied to Optimization of Instrument Panel and Workplace Layout." *Human Factors*. 9: 295-300. 1967.
- Gavett, J. W. and N. V. Plyter. "The Optimal Assignment of Facilities to Locations by Branch and Bound." *Operations Research*. 14:210-232. 1966.
- Genaidy, A. M. and S. S. Asfour. "Effects of Frequency and Load of Lift on Endurance Time." *Ergonomics*. 32: 51-57. 1989.
- Genaidy, A. M., T. M. Khalil, S. S. Asfour and R. C. Duncan. "Human Physiological Capabilities for Prolonged manual Lifting Tasks." *IIE Transactions*. 23(3): 270-280. 1990.
- Gilb, T. and G. Weinberg. *Humanized Input*. Winthrop Computer Systems Series. Cambridge, MA: Winthrop Publishers, 1977.
- Gilmore, P. C. "Optimal and Suboptimal Algorithms for the Quadratic Assignment Problem." *Journal of Society of Industrial and Applied Mathematics*. 10:305-313. 1962.
- Goldenberg, A. A. and D. L. Lawrence. "A Generalized Solution to the Inverse Kinematics of Robotic Manipulators." *Journal of Dynamic Systems Measurement and Control*. 107: 103-106. March 1985.
- . "A New Approach to Kinematic Control of Robot Manipulators." *Journal of Dynamic Systems Measurement and Control*. 109: 97-103. June 1987.
- Grassmann, W. K. "Review of Markov1." *OR/MS Today*. 17(6): 32-35. December 1990.
- Haynes, R. M. "The ATM at Age Twenty: A Productivity Paradox." *National Productivity Review*. 9: 273-281. 1990.
- Held, M. and R. Karp. "The Traveling Salesman Problem and Minimum Spanning Trees." *Operations Research*. 18(6): 1126-1138. 1970.
- Hendy, K. C. "A Model for Human-Machine-Human Interaction in Workspace Layout Problems." *Human Factors*. 31:593-610. October 1989.
- Hill, S. G. and K. H. E. Kroemer. "Preferred Declination of the Line of Sight." *Human Factors*. 28(2): 127-134. April 1986.
- Hillier, F. S. "Quantitative Tools for Plant Layout Analysis." *Journal of Industrial Engineering*. 14:33-40. 1963.

- Hillier, F. S. and M. M. Connors. "Quadratic Assignment Problem Algorithms and the Location of Indivisible Facilities." *Management Science*. 13:42-57. 1966.
- Hillier, F. S. and G. Lieberman. *Introduction to Operations Research*, 4th ed. Oakland: Holden-Day, 1986.
- Hitchings, G. G. "The Application of Optimizing Techniques and Statistical Control Theory to a Generalized Layout." Institute of Science and Technology, University of Wales. Technical Note EPTN3. January 1968.
- Howard, R. A. *Dynamic Probabilistic Systems, Volume II, Semi-Markov and Decision Processes*. New York: John Wiley and Sons, 1971.
- Hughes, D. "Glass Cockpit Study Reveals Human Factors Problems." *Aviation Week and Space Technology*. 131:32-36. August 7, 1989.
- Kantowitz, B. H. and R. D. Sorkin. *Human Factors: Understanding People-System Relationships*. New York: John Wiley & Sons, 1983.
- Karp, R. M. "An Algorithm to Solve the $m \times n$ Assignment Problem in Expected Time $O(mn \log n)$." *Networks*. 10: 143-152. 1980.
- Khaopravetch, K., and R. Nanda. "Assessing Solution Efficiency for Quadratic Assignment Problems." *Industrial Engineering*. 22: 51-53. April 1990.
- Konz, S. *Work Design: Industrial Ergonomics*, 3rd ed. Worthington, OH: Publishing Horizons, 1990.
- Koopmans, T. C. and M. J. Beckmann. "Assignment Problems and the Location of Economic Activities." *Econometrica*. 25: 53-76. 1957.
- Kroemer, E. H. Eberhard. "Human Strength: Terminology, Measurement and Interpretation of Data." *Human Factors*. 12: 297-313. June 1970.
- Lawler, E. L. "The Quadratic Assignment Problem." *Management Science*. 13:42-57. 1963.
- _____. *Combinatorial Optimization: Networks and Matroids*. New York: Holt, Rinehart and Winston, 1976.
- Ledgard, H. and A. Singer. *Directions in Human Factors for Interactive Systems*. New York: Springer Verlag, 1981.
- Lee, C. S. G. "Robot Arm Kinematics, Dynamics and Control." *Computer*. 15: 62-80. December 1982.
- Lee, R. C. and J. M. Moore. "CORELAP - Computerized Relationship Layout Planning." *Journal of Industrial Engineering*. 18: 195-200. 1967.
- Lee, S. M., L. J. Moore, and B. W. Taylor. *Management Science*, 2nd ed. Dubuque, Iowa: Wm. C. Brown, 1985.

- Lisboa, J. J. "Quantification of Human Error and Common-Mode Failures in Man/Machine Systems." *IEEE Transactions Energy Conversion*. 3: 292-9. June 1988.
- Lutz, M. C. and A. Chapanis. "Expected Location of Digits and Letters on Ten-Button Keysets." *Journal of Applied Psychology*. 39(5): 314-17. 1955.
- Martin, J. *Design of Man-Computer Dialogues*. Prentice-Hall: Englewood Cliffs, 1973
- Martin, S. and D. Clark. "Moving to ATMs - An Analytical Approach". *The Magazine of Bank Administration*. 28-33. December 1982.
- Mathsoft, Inc. *MathCAD Version 2.0*. Mathsoft Publishing Co. 1989.
- McCormick, E. J. and M. S. Sanders. *Human Factors in Engineering and Design*, 5th ed. New York: McGraw-Hill, 1982.
- McCormick, M. J. and W. Wrennall. "A Step Beyond Computer-Aided Layout." *Industrial Engineering*. 17: 40-42. May 1985.
- Metropolis, N. and S. Ulam. "The Monte Carlo Method." *Journal of the American Statistical Association*. 44: 335-341. 1949.
- Miller, R. A., R. J. Jagacinski, R. B. Nalavade, and W. W. Johnson. "Plans and the Structure of Target Acquisition Behavior." *Proceedings of the Human Factors Society*. 25: 571-575. 1981.
- Miller, R. B. "Response Time in Man-Computer Conversational Transactions." *Proceedings of the National Computer Conference*. Montvale, NJ: AFIPS Press, 268-277. 1968.
- Montgomery, E. B. "Bringing Manual Input into the 20th Century; New Keyboard Concepts." *Computer*. 15: 11-19. March 1982.
- Moore, T. G. "Industrial Push Buttons." *Applied Ergonomics*. 6: 33-38. 1975.
- Morland, D. V. "Human Factors Guidelines for Terminal Interface Design." *Communications of the ACM*. 26: 484-494. July 1983.
- NASA. *Anthropometric Source Book - Volume I: Anthropometric Data for Designers; Volume II: A Handbook of Anthropometric Data; Volume III: Annotated Bibliography of Anthropometry*. Yellow Springs, OH: National Aeronautics and Space Administration Scientific and Technical Information Office. 1978.
- Nemeth, S. E. and K. E. Blache. "Ergonomic Evaluation of Two-Hand Control Location." *Human Factors*. 24: 567-571. October 1982.
- Norman, D. A. "Commentary: Human Error and the Design of Computer Systems." *Communications of the ACM*, 33: 4-7. January 1990.

- Nugent, C. E., T. E. Vollmann, and J. Ruml. "An Experimental Comparison of Techniques for the Assignment of Facilities to Locations." *Operations Research*, 16: 150-173. 1968.
- Parker, J.F., Jr. and V. R. West, eds. *Bioastronautics Data Book*, 2nd ed. NASA SP-3006. Washington, D.C.: U.S. Government Printing Office, 1973.
- Paul, R. *Robot Manipulators: Mathematics, Programming and Control*. Cambridge, MA: MIT Press, 1981.
- _____. *Robot Manipulators*. Cambridge MA: MIT Press, 1982.
- Phillips, Mark D. "The Quantification of Operational Suitability." *Computer*. 20: 63-71. February, 1987.
- Red, W. E. "Robot Path Planning in 3-Dimensions Using the Direct Subspace." *Journal of Dynamic Systems Measurement and Control*. 109: 238-244. September 1987.
- Reason, J. "Six CRT Touch Screens Simulate a Full-Scope Control Panel." *Power*. 133: 29-31. July 1989.
- Rodgers, S. H., ed. *The Ergonomics Group Health and Environment Laboratories, Eastman Kodak Company. Ergonomic Design for People at Work: A Source Book for Human Factors*. New York: Van Nostrand Reinhold, 1986.
- Roebuck, J. A. Jr., K. H. E. Kroemer, and W. G. Thomson. *Engineering Anthropometry Methods*. New York: John Wiley and Sons, 1975.
- Saaty, T. *Mathematical Methods of Operations Research*. New York: McGraw-Hill, 1959.
- Schwartz, J. T. and M. Sharir. "A Survey of Motion Planning and Related Geometric Algorithms." *Artificial Intelligence*. 37: 157-169. December 1988.
- Scott, W. B. "777's Flight Deck Reflects Strong Operations Influence." *Aviation Week and Space Technology*. 134: 52-58. June 3, 1991.
- Seidenberg, J. P. "Cirrus and Plus Announce August Date for Start of Terminal Duality." *Card News*. 5: 4-5. July 16, 1990.
- Sharir, M. "Algorithmic Motion Planning in Robotics." *Computer*. 22:9-20. March 1989.
- Siegel, A. I., J. J. Wolf, and J. Pilitis. "A New Method for the Scientific Layout of Workspaces." *Applied Ergonomics*. 13(2): 87-90. 1982
- Swain, J. "Linear Programming: Software Survey." *OR/MS Today*. 17(5). October 1990.

- Taha, H. A. Operations Research, 4th ed. New York: Macmillan, 1987.
- Taube, P. M. "The Influence of Selected Factors on the Frequency of ATM Usage." *Journal of Retail Banking*. 10: 41-52. Spring 1988.
- Tichauer, E. R. Biomechanical Basis of Ergonomics. New York: Wiley Interscience, 1978.
- Tillmann, P. and Tillmann, B. Human Factors Essentials - An Ergonomics Guide for Designers, Engineers, Scientists, and Managers. New York: McGraw-Hill, 1991.
- Tullis, T. "The Formatting of Alphanumeric Displays." *Human Factors*. 25(6): 657-82. 1983.
- U.S. Bureau of the Census. Statistical Abstract of the United States: 1990 (110th edition). Washington: U.S. Department of Commerce, Government Printing Office. 1990.
- U.S. Department of Defense. Human Engineering Design Criteria for Military Systems, Equipment and Facilities. Washington: U.S. Government Printing Office. DOD Military Standard MIL-STD-1472C. 1981.
- U.S. Department of Defense. Human Engineering Guide for Army Material. Washington: U.S. Government Printing Office. DOD Military Handbook MIL-HDBK-759A. 1981.
- Van Cott, H. P. and R. G. Kinkade, eds. Human Engineering Guide to Equipment Design. New York: John Wiley, 1972.
- Van der Velde, M. "ATMs: The Product, Placement and Pricing." *Bank Management*. 24-28. November 1986.
- _____. "EFT Transactions: Growth and Direction." *Magazine of Bank Administration*. 36-38. December 1982.
- _____. "Two New Models Tell How Much an ATM Transaction Really Costs." *The Magazine of Bank Administration*. 34-40. November 1986
- Vollmann, T. E. and E. S. Buffa. "The Facilities Layout Problem in Perspective." *Management Science*. 12:450-468. 1966.
- West, D. H. "Algorithm 608 - Approximate Solution to the Quadratic Assignment Problem." *ACM Transactions on Mathematical Software*. 9(4): 461-466. 1983.
- Wiker, S. F., G. D. Langolf, and D. B. Chaffin. "Arm Posture and Human Movement Capability." *Human Factors*. 31(4): 421-441. 1989.
- Willeges, R. C. and B. H. Willeges. "Modeling the Human Operator in Computer-Based Data Entry." *Human Factors*. 24: 285-99. 1982.

_____. "User Considerations in Computer-Based Interfaces." *Human Factors*. 24: 421-441. 1982.

Winston, W. *Operations Research: Applications and Algorithms*. Boston: PWS-Kent, 1987.

Woodson, W. E., M. P. Ranc Jr., and D. W. Conover. "Design of Industrial Workplaces" Chapter 9 in Van Cott and Kinkade. 381-418. 1972.

Woodson, W. E. *Human Factors Design Handbook: Information and Guidelines for the Design of Systems, Facilities, and Products for Human Use*. New York: McGraw-Hill, 1981.

Appendix A. Solution to Joint Problem for 5th Percentile Female -
 Numerical Solution and General Method for Kinematic Solution to
 Manipulator Problem.

1. Upper and lower arm link lengths of 5th percentile female subject (from Rodgers, 1983).

$$a := 13.43 \quad b := 17.32$$

2. Panel coordinates for a given point being analyzed:

$$x := -21 \quad y := 18 \quad z := 12$$

3. Define units for angular measurements:

$$\text{rad} \equiv 1 \quad \text{deg} := \frac{\pi}{180} \cdot \text{rad}$$

4. Determine initial conditions for seed values from mid-range of feasible range of motion (Rodgers, 1983).

$$\theta := 1.5 \quad \phi := 1.3 \quad \xi := 1.1$$

5. Solve the problem and find the set of joint angles:

Given

6. Transformation equations for each coordinate:

$$\begin{aligned} b \cdot \cos(\theta) \cdot \cos(\phi) \cdot \cos(\xi) - b \cdot \sin(\theta) \cdot \sin(\phi) \cdot \cos(\xi) + a \cdot \cos(\theta) \cdot \cos(\xi) &\approx x \\ b \cdot \sin(\theta) \cdot \cos(\phi) + b \cdot \cos(\theta) \cdot \sin(\phi) + a \cdot \sin(\theta) &\approx y \\ -b \cdot \cos(\theta) \cdot \cos(\phi) \cdot \sin(\xi) + b \cdot \sin(\theta) \cdot \sin(\phi) \cdot \sin(\xi) - a \cdot \cos(\theta) \cdot \sin(\xi) &\approx z \end{aligned}$$

7. Motion constraints for each joint, in radians (Rodgers, 1983).

$$-1.047 \cdot \text{rad} < \theta < 3.14 \cdot \text{rad}$$

$$0 \cdot \text{rad} < \phi < 2.62 \cdot \text{rad}$$

$$0 \cdot \text{rad} < \xi < 2.27 \cdot \text{rad}$$

8. The computer program's algorithm then finds the solution vector (V), and error vector values (ERR) as follows:

$$V := \text{Find}(\theta, \phi, \xi)$$

$$E := \text{ERR}$$

9. Since a numerical solution method is used, the results are verified by checking the magnitude of the error. If the value of ERR is sufficiently small ($\text{ERR} < 0.01$), the answer is considered acceptable.

$$V = \begin{bmatrix} 2.277 \\ 0.399 \\ 0.519 \end{bmatrix} \cdot \text{rad} \quad \text{or} \quad V = \begin{bmatrix} 130.444 \\ 22.867 \\ 29.745 \end{bmatrix} \cdot \text{deg}$$

$$E = 7.105 \cdot 10^{-15} \quad (\text{well within acceptable limits})$$

Appendix B. Computation of Predicted Endurance Times for Selected Joint Configurations.

- Given the relationship between force (F) and endurance time (t), (from Kroemer, 1970; Kroemer, et al., 1975).

i := 1 ..9

	F := i	t := i
	100	.35
	75	.50
	50	1
F - % MVC Applied	35	2
	31	2.5
t - Endurance Time	26	4
	21	6
	21	8
	20	10
	Percent	Minutes

- Define the regression equation:

$$a := 100 \quad b := -1 \quad c := 20$$

$$G_i := a \cdot e^{b \cdot t_i} + c$$

- For the available extension forces at elbow angles (Adapted from Knapik, Wright, and Mardsley, 1983).

i := 1 ..6

	θ := i	P := i
	30	55
	50	75
	70	90
	90	100
	110	85
	120	80
	Degrees	Minutes

4. Analyze a task requiring 5 pounds of force application by a subject with a peak MVC of 30 pounds:

FR := 5 lbs. force required

FA := 30 lbs. force available

5. Determine the actual forces available due to the angle effect.

$$A_i := P_i \cdot \frac{FA}{100}$$

6. Relate the force requirement of the task (FR) to the relative percentage of actual available MVC (R).

$$R_i := \frac{FR_i}{A_i}$$

7. From the regression equation, express the endurance time (t) as a function of the required force (R)

$$\text{Endurance Time (mins)} \quad t_i := -\ln \left[R_i - \frac{20}{100} \right]$$

8. Compute the predicted endurance times for each joint angle.

Trial	Joint Angle	Available max Force	Req'd Force (% of MVC)	Predicted Endurance time
i	ϕ i	A i	$R \cdot 100$ i	T i
1	30	16.5	30.3	2.3
2	50	22.5	22.2	3.8
3	70	27	18.5	61.3
4	90	30	16.7	68.5
5	110	25.5	19.6	49.5
6	120	24	20.8	4.8
	Degrees	Pounds	Percent	Minutes

Appendix C. Computation of Steady-State Probabilities from One-Step Transition Matrix - (Numerical Example from Case II Model).

Transition Matrix - (Example from Case II).

$$P := \begin{bmatrix} .1 & .9 & 0 & 0 & 0 & 0 & 0 \\ 0 & .132 & 0 & .868 & 0 & 0 & 0 \\ 0 & 0 & .132 & 0 & .154 & .071 & .643 \\ 0 & 0 & .711 & .033 & 0 & .256 & 0 \\ 0 & 0 & 0 & 0 & 0 & 1 & 0 \\ 1 & 0 & 0 & 0 & 0 & 0 & 0 \\ 0 & 0 & 0 & 0 & 0 & 1 & 0 \end{bmatrix}$$

$$P^2 = \begin{bmatrix} 0.01 & 0.209 & 0 & 0.781 & 0 & 0 & 0 \\ 0 & 0.017 & 0.617 & 0.143 & 0 & 0.222 & 0 \\ 0.071 & 0 & 0.017 & 0 & 0.02 & 0.806 & 0.085 \\ 0.256 & 0 & 0.117 & 0.001 & 0.109 & 0.059 & 0.457 \\ 1 & 0 & 0 & 0 & 0 & 0 & 0 \\ 0.1 & 0.9 & 0 & 0 & 0 & 0 & 0 \\ 1 & 0 & 0 & 0 & 0 & 0 & 0 \end{bmatrix}$$

$$P^3 = \begin{bmatrix} 0.001 & 0.037 & 0.555 & 0.207 & 0 & 0.2 & 0 \\ 0.222 & 0.002 & 0.183 & 0.02 & 0.095 & 0.08 & 0.397 \\ 0.813 & 0.064 & 0.002 & 0 & 0.003 & 0.106 & 0.011 \\ 0.085 & 0.23 & 0.016 & 0 & 0.018 & 0.575 & 0.075 \\ 0.1 & 0.9 & 0 & 0 & 0 & 0 & 0 \\ 0.01 & 0.209 & 0 & 0.781 & 0 & 0 & 0 \\ 0.1 & 0.9 & 0 & 0 & 0 & 0 & 0 \end{bmatrix}$$

$$P^4 = \begin{bmatrix} 0.2 & 0.006 & 0.221 & 0.039 & 0.086 & 0.092 & 0.357 \\ 0.103 & 0.2 & 0.038 & 0.003 & 0.028 & 0.51 & 0.118 \\ 0.188 & 0.741 & 0 & 0.055 & 0 & 0.014 & 0.001 \\ 0.584 & 0.106 & 0.002 & 0.2 & 0.003 & 0.095 & 0.01 \\ 0.01 & 0.209 & 0 & 0.781 & 0 & 0 & 0 \\ 0.001 & 0.037 & 0.555 & 0.207 & 0 & 0.2 & 0 \\ 0.01 & 0.209 & 0 & 0.781 & 0 & 0 & 0 \end{bmatrix}$$

$$P^5 = \begin{bmatrix} 0.112 & 0.181 & 0.057 & 0.006 & 0.034 & 0.468 & 0.142 \\ 0.52 & 0.119 & 0.007 & 0.174 & 0.006 & 0.149 & 0.025 \\ 0.033 & 0.267 & 0.039 & 0.645 & 0 & 0.016 & 0 \\ 0.153 & 0.539 & 0.142 & 0.099 & 0 & 0.064 & 0.001 \\ 0.001 & 0.037 & 0.555 & 0.207 & 0 & 0.2 & 0 \\ 0.2 & 0.006 & 0.221 & 0.039 & 0.086 & 0.092 & 0.357 \\ 0.001 & 0.037 & 0.555 & 0.207 & 0 & 0.2 & 0 \end{bmatrix}$$

$$P^6 = \begin{bmatrix} 0.479 & 0.125 & 0.012 & 0.157 & 0.009 & 0.181 & 0.036 \\ 0.202 & 0.484 & 0.125 & 0.109 & 0.001 & 0.076 & 0.004 \\ 0.019 & 0.065 & 0.464 & 0.253 & 0.006 & 0.168 & 0.025 \\ 0.08 & 0.209 & 0.089 & 0.471 & 0.022 & 0.037 & 0.092 \\ 0.2 & 0.006 & 0.221 & 0.039 & 0.086 & 0.092 & 0.357 \\ 0.112 & 0.181 & 0.057 & 0.006 & 0.034 & 0.468 & 0.142 \\ 0.2 & 0.006 & 0.221 & 0.039 & 0.086 & 0.092 & 0.357 \end{bmatrix}$$

$$P^7 = \begin{bmatrix} 0.229 & 0.448 & 0.113 & 0.114 & 0.002 & 0.086 & 0.008 \\ 0.096 & 0.245 & 0.094 & 0.424 & 0.019 & 0.042 & 0.08 \\ 0.17 & 0.026 & 0.241 & 0.065 & 0.071 & 0.129 & 0.298 \\ 0.045 & 0.099 & 0.347 & 0.197 & 0.014 & 0.241 & 0.057 \\ 0.112 & 0.181 & 0.057 & 0.006 & 0.034 & 0.468 & 0.142 \\ 0.479 & 0.125 & 0.012 & 0.157 & 0.009 & 0.181 & 0.036 \\ 0.112 & 0.181 & 0.057 & 0.006 & 0.034 & 0.468 & 0.142 \end{bmatrix}$$

$$P^8 = \begin{bmatrix} 0.109 & 0.266 & 0.096 & 0.393 & 0.017 & 0.047 & 0.073 \\ 0.052 & 0.119 & 0.314 & 0.227 & 0.014 & 0.214 & 0.06 \\ 0.146 & 0.156 & 0.078 & 0.025 & 0.037 & 0.403 & 0.155 \\ 0.245 & 0.054 & 0.186 & 0.093 & 0.053 & 0.146 & 0.223 \\ 0.479 & 0.125 & 0.012 & 0.157 & 0.009 & 0.181 & 0.036 \\ 0.229 & 0.448 & 0.113 & 0.114 & 0.002 & 0.086 & 0.008 \\ 0.479 & 0.125 & 0.012 & 0.157 & 0.009 & 0.181 & 0.036 \end{bmatrix}$$

Appendix D. Solution to Joint Angle Problem for 6-Jointed Manipulator
(from Lee, 1982).

$$\vartheta_1 = \tan^{-1} \left[\frac{\pm p_y \sqrt{p_x^2 + p_y^2 - d_2^2} - d_2 p_x}{\pm p_x \sqrt{p_x^2 + p_y^2 - d_2^2} + d_2 p_y} \right]$$

$$\vartheta_2 = \tan^{-1} \left[\frac{-\left(p_z(a_2 + d_4 S_3) + (d_4 C_3)(\pm \sqrt{p_x^2 + p_y^2 - d_2^2}) \right)}{p_z(d_4 C_3) - (a_2 + d_4 S_3)(\pm \sqrt{p_x^2 + p_y^2 - d_2^2})} \right]$$

$$\vartheta_3 = \tan^{-1} \left[\frac{p_x^2 + p_y^2 + p_z^2 - d_4^2 - a_2^2 - d_2^2}{\pm \sqrt{4d_4^2 a_2^2 - (p_x^2 + p_y^2 + p_z^2 - d_4^2 - a_2^2 - d_2^2)^2}} \right]$$

$$\vartheta_4 = \tan^{-1} \left[\frac{C_1 a_y - S_1 a_x}{C_1 C_{23} a_x + S_1 C_{23} a_y - S_{23} a_z} \right]$$

$$\vartheta_5 = \tan^{-1} \left[\frac{(C_1 C_{23} C_4 - S_1 S_4) a_x + (S_1 C_{23} C_4 + C_1 S_4) a_y - C_4 S_{23} a_z}{C_1 S_{23} a_x + S_1 S_{23} a_y + C_{23} a_z} \right]$$

$$\vartheta_6 = \tan^{-1} \left[\frac{(-S_1 C_4 - C_1 C_{23} S_4) n_x + (C_1 C_4 - S_1 C_{23} S_4) n_y + (S_4 S_{23}) n_z}{(-S_1 C_4 - C_1 C_{23} S_4) s_x + (C_1 C_4 - S_1 C_{23} S_4) s_y + (S_4 S_{23}) s_z} \right]$$

$$-180^\circ \leq \vartheta_1, \vartheta_2, \vartheta_3, \vartheta_4, \vartheta_5, \vartheta_6 \leq 180^\circ$$

- Degenerate case ($\vartheta_5 \approx 0$)
 ϑ_4 = current value of ϑ_4 or 0 and
 $(\vartheta_4 + \vartheta_6)$ = total angle required to align the orientation.
- For a given arm configuration,
 $(\vartheta_1, \vartheta_2, \vartheta_3, \vartheta_4, \vartheta_5, \vartheta_6)$ is a set of solutions and
 $(\vartheta_1, \vartheta_2, \vartheta_3, \vartheta_4 + \pi, -\vartheta_5, \vartheta_6 + \pi)$ is another set of solutions.

Appendix E. Computer Program for Solving Simplex Linear Programming Problems (Adapted from Taha, 1987).

```

DIMENSION A(50,100), B(50), CJ(100), NXI(50),
*KODE(50),C(50,100),D(100),IN(50), IS(50,2)
IIM=50
IIN=100
C
      SIMPLEX PROGRAM FOR LINEAR PROGRAMMING
      INTEGER GE,EQ
      DATA MIN/3HMIN/, MAX/3HMAX/,GE/2HGE/,LE/2HLE/, EQ/2HEQ/
61  FORMAT (A4, 10I3)
63  FORMAT (16F5.0)
64  FORMAT (1H1, 20X, 'PROBLEM-',A4,1H(,A3,1H))
65  FORMAT (/ ' ITERATION NO.', I2)
66  FORMAT (I24, 9I10)
67  FORMAT (10X, 3H X(, I2, 1H), 10F10.2, 2X, F10.2)
71  FORMAT(// ' *** OPTIMUM TABLEAU (ITERATION #', I2,') ***')
72  FORMAT(/ ' UNBOUNDED SOLUTION -- X(',I2,') CANNOT BE MADE BASIC')
73  FORMAT (10X, ' X( 0)', 10F10.2, 2X, F10.2)
74  FORMAT (' NO FEASIBLE SOLUTION SINCE ARTIF. VAR. X(',I2,
* ' ') IS BASIC AND POSITIVE')
75  FORMAT ('      OBJ COEFF',10F10.2, 2X, F10.2)
80  FORMAT(// 'DO YOU NEED INSTRUCTIONS (TYPE 1=YES OR 0=NO)')
85  FORMAT('DATA MUST BE ENTERED AS FOLLOWS:/'
* 'LINE 1: PROBLEM NAME, # CONSTRS, # VARS, # UNRESTRICTED VARS'/
* '      (IF NO UNRESTRICTED VARS, YOU MUST TYPE 0 "ZERO")'/
* 'LINE 2: MAX OR MIN, OBJ COEFFS'/
* 'FOLLOWING LINES: CONSTR TYPE(GE,LE OR EQ), CONSTR COEFFS, RHS/'
* 'LAST LINE: INDICES OF UNRESTRICTED VARS. (IF NONE, DELETE LINE)'/
* '-----')
* 'EXAMPLE'/
* '      MAXIMIZE Z = 2X1      + 4X3 + 5X4/'SUBJECT TO '/
* '      X1 + X2 - 3X3 - 2X4 <= 1'/
* '      5X1 + 7X2 + 2X3 - X4 = 8'/
* '      9X1 + X2      + 6X3 >= 9'/
* '      X1,X2 UNRESTR, X3 >=0'/
* 'INPUT DATA ARE:/'
* ' 'EXAMPLE',3,4,2      <HIT RETURN>/'
* ' 'MAX',2,0,4,5      <HIT RETURN>/'
* ' 'LE',1,1,-3,-2,1   <HIT RETURN>/'
* ' 'EQ',5,7,2,-1,8    <HIT RETURN>/'
* ' 'GE',9,1,0,6,9     <HIT RETURN>/'
* ' 1,2                <HIT RETURN>/'
* '-----')
87  FORMAT(// 'NOTE: VALUE OF "M" FOR ARTIFICIAL VARS IS "1E4".')
90  FORMAT(// ' DATA SET IS NOW COMPLETE'//)
95  FORMAT('DO YOU WANT TO PRINT ALL TABLEAUS (TYPE 1=YES OR 0=NO)')
500 FORMAT(5X,'ORIGINAL X(',I2,') = X(',I2,') - X(',I2,') = ',F10.4)
510 FORMAT(5X,'ORIGINAL X(',I2,') = X(',I2,') = ', F10.4)
520 FORMAT(/ ' *** INITIAL TABLEAU ***')
530 FORMAT('THE UNRESTR VARS RESULTED IN THE FOLLOWING SUBSTITUTION:')
540 FORMAT(// 'DO YOU WANT TO RUN A NEW PROBLEM (TYPE 1=YES OR 0=NO)')
550 FORMAT(/ 'PLS ENTER DATA NOW')
560 FORMAT(// ' *** OPTIMAL SOLUTION ***'/'OBJECTIVE VALUE = ',F10.4)
580 FORMAT('      X(',I2,') = ', F10.4)

```

```

TOL=.00001
WRITE(6,80)
READ(9,*) INSTR
IF(INSTR.EQ.0) GOTO 2323
WRITE(6,85)
2323 WRITE (6,550)
CV=1E4
READ (9,*) PROB, M, N, KUN
READ(9,*) KODE(1),(D(J), J=1, N)
N1=N
NN=N
NPR=0
IF (KODE(1).EQ.MAX) GOTO 5
KOD=1
GOTO 6
5 CV=-CV
KOD=-1
6 M1=M + 1
DO 1000 I=2, M1
1000 READ(9,*) KODE(I),(C(I,J), J=1, N), B(I)
IF (KUN.EQ.0) GOTO 290
READ(9,*)(IN(I), I=1, KUN)
290 KNT=0
WRITE (6,90)
WRITE (6,95)
READ(9,*) NPR
DO 399 I=1, N
IF (KUN.EQ.0) GOTO 305
DO 300 J=1, KUN
IF (IN(J).EQ.I) GOTO 320
300 CONTINUE
305 I1=I+KNT
IS(I,1)=I1
IS(I,2)=0
CJ(I1)=D(I)
DO 310 I2=2, M1
310 A(I2,I1)=C(I2,I)
GOTO 399
320 KNT=KNT+1
I1=KNT+I-1
I2=I1+1
IS(I,1)=I1
IS(I,2)=I2
CJ(I1)=D(I)
CJ(I2)=-D(I)
DO 330 L=2,M1
A(L,I1)=C(L,I)
330 A(L,I2)=-C(L,I)
399 CONTINUE
N=N+KUN
DO 410 I=2,M1
IF (KODE(I).NE.GE) GOTO 410
N=N+1
A(I,N)=-1
410 CONTINUE
AV=0

```

```

DO 420 I=2,M1
N=N+1
A(I,N)=1
NXI(I)=N
IF (KODE(I).EQ.LE) GOTO 420
AV=1
CJ(N)=CV
420 CONTINUE
2222 ITER=0
IF (KUN.EQ.0) GOTO 3333
WRITE (6,530)
DO 690 I =1, N1
IF (IS(I,2).EQ.0) GOTO 600
IF (IS(I,1).EQ.IS(I,2)) GOTO 600
WRITE (6,500) I,IS(I,2),IS(I,1)
GOTO 690
600 WRITE(6,510)I, IS(I,1)
690 CONTINUE
3333 IF (AV.EQ.1) WRITE (6,87)
WRITE(6,64) PROB, KODE(1)
WRITE (6,520)
C PRINT TABLEAU
IF (ITER.EQ.0) GOTO 4444
IF (NPR.EQ.0) GOTO 55
1212 WRITE(6,65) ITER
4444 N1=1
N2=6
43 IF (N2-N) 45,45,44
44 N2=N
45 IF (ITER.EQ.0) WRITE(6,75) (CJ(J), J=N1, N2)
WRITE(6,66) (J, J=N1,N2)
WRITE(6,73)(A(1,J), J=N1, N2), B(1)
DO 48 I=2, M1
48 WRITE(6,67) NXI(I), (A(I,J), J=N1, N2), B(I)
IF (N2-N) 52,55,55
52 N1=N1+6
N2=N2+6
GOTO 43
55 CONTINUE
IF (NPR.NE.2) GOTO 21
WRITE (6,560) B(1)
DO 800 J=1,NN
D(J)=0
DO 800 I=2, M1
K=NXI(I)
IF (K.EQ.IS(J,1)) D(J)=B(I)
800 IF (K.EQ.IS(J,2)) D(J)=-B(I)
DO 810 J=1, NN
IF (KUN.EQ.0) WRITE (6,580) J, D(J)
IF(KUN.GT.0.AND.IS(J,2).EQ.0) WRITE(6,510) J,IS(J,1), D(J)
IF (KUN.GT.0.AND.IS(J,2).NE.0) WRITE(6,500) J,IS(J,2),IS(J,1),D(J)
810 CONTINUE
GOTO 1
C COMPUTE Z AND ZC
21 DO 25 J=1,N

```



```

        A(1,J)=0.
        DO 24 I=2, M1
            K=NXI(I)
24      A(1,J)=A(1,J)+CJ(K)*A(I,J)
25      A(1,J)=A(1,J)-CJ(J)
        B(1)=0.
        DO 28 I=2, M1
            K=NXI(I)
28      B(1)=B(1)+CJ(K)*B(I)
C      DETERMINE PIVOT COLUMN
        ZCM=A(1,1)
        JM=1
        DO 109 J=2,N
            IF (KOD.EQ.1) GOTO 106
105     IF (A(1,J)-ZCM) 107, 109, 109
106     IF (A(1,J)-ZCM) 109, 109, 107
107     ZCM=A(1,J)
        JM=J
109     CONTINUE
C      CHECK FOR OPTIMAL
        CK=KOD*ZCM
        IF (CK.GT.TOL) GOTO 131
123     DO 124 I=2, M1
            K=NXI(I)
            IF (CJ(K).NE.CV) GOTO 124
            IF (B(I).LE.TOL) GOTO 124
            WRITE(6,74) K
            GOTO 1
124     CONTINUE
        WRITE(6,71) ITER
        NPR=2
        GOTO 4444
C      DETERMINE PIVOT ROW
131     XM=1.0E38
        IM=0
        DO 139 I=2, M1
            IF (A(I,JM)) 139,139,135
135     XX=B(I)/A(I,JM)
            IF (XX-XM) 137,139,139
137     XM=XX
        IM=I
139     CONTINUE
        IF (IM) 141,141,151
141     WRITE(6,72) JM
        GOTO 1
C      PERFORM PIVOT OPERATION
151     XX=A(IM,JM)
        B(IM)=B(IM)/XX
        ITER=ITER+1
        DO 154 J=1,N
154     A(IM,J)=A(IM,J)/XX
        DO 161 I=1, M1
            IF (I-IM) 157,161,157

```

```
157 XX=A(I,JM)
    B(I)=B(I)-XX*B(IM)
    DO 160 J=1,N
160 A(I,J)=A(I,J)-XX*A(IM,J)
161 CONTINUE
    NXI(IM)= JM
    IF (NPR.EQ.1)GOTO 1212
    GOTO 21
```

```
    DO 700 J=1,IIN
    A(I,J)=0
    CJ(J)=0
700 C(I,J)=0
    ITER=0
    GOTO 2323
    END
```

Appendix F. Linear Assignment Tableaus for ATM Control Panel Problem.

Loc. j	Control i					
	1 Card Slot	2 Key Pad	3 Functn Key	4 Deposit Slot	5 Receipt Slot	6 Cash Disp
1	0.8594	1.6922	1.8914	0.1188	0.9141	0.4258
2	0.4231	0.8331	0.9312	0.0585	0.4500	0.2096
3	0.3323	0.6544	0.7314	0.0459	0.3535	0.1647
4	0.2736	0.5388	0.6022	0.0378	0.2910	0.1356
5	0.2326	0.4579	0.5118	0.0321	0.2474	0.1152
6	0.1890	0.3722	0.4160	0.0261	0.2010	0.0936
7	0.1491	0.2935	0.3280	0.0206	0.1585	0.0738
8	0.1809	0.3563	0.3982	0.0250	0.1924	0.0896
9	0.1491	0.2935	0.3280	0.0206	0.1585	0.0738
10	0.1890	0.3722	0.4160	0.0261	0.2010	0.0936
11	0.5116	1.0074	1.1260	0.0707	0.5442	0.2535
12	0.3929	0.7736	0.8646	0.0543	0.4179	0.1946
13	0.2835	0.5582	0.6240	0.0392	0.3015	0.1405
14	0.2326	0.4579	0.5118	0.0321	0.2474	0.1152
15	0.1507	0.2967	0.3316	0.0208	0.1603	0.0747
16	0.2249	0.4429	0.4951	0.0311	0.2393	0.1115
17	0.2540	0.5002	0.5591	0.0351	0.2702	0.1259
18	0.2619	0.5157	0.5764	0.0362	0.2786	0.1298
19	0.2540	0.5002	0.5591	0.0351	0.2702	0.1259
20	0.2249	0.4429	0.4951	0.0311	0.2393	0.1115
21	0.4365	0.8595	0.9607	0.0603	0.4643	0.2163
22	0.3245	0.6389	0.7142	0.0448	0.3451	0.1608
23	0.2570	0.5061	0.5657	0.0355	0.2734	0.1273
24	0.1890	0.3722	0.4160	0.0261	0.2010	0.0936
25	0.2249	0.4429	0.4951	0.0311	0.2393	0.1115

Notes

1. Control Dummy1 thru Dummy44 (i = 7 thru i = 50) not shown.
2. Unit assignment costs for Dummy1 thru Dummy44 are zero.

Loc. No.	Control i					
	1 Card Slot	2 Key Pad	3 Functn Key	4 Deposit Slot	5 Receipt Slot	6 Cash Disp
26	0.2696	0.5309	0.5934	0.0373	0.2868	0.1336
27	0.2918	0.5745	0.6422	0.0403	0.3103	0.1446
28	0.2989	0.5886	0.6579	0.0413	0.3179	0.1481
29	0.2918	0.5745	0.6422	0.0403	0.3103	0.1446
30	0.2696	0.5309	0.5934	0.0373	0.2868	0.1336
31	0.4015	0.7905	0.8836	0.0555	0.4270	0.1989
32	0.3030	0.5967	0.6669	0.0419	0.3223	0.1501
33	0.2391	0.4709	0.5263	0.0330	0.2543	0.1185
34	0.1491	0.2935	0.3280	0.0206	0.1585	0.0738
35	0.2540	0.5002	0.5591	0.0351	0.2702	0.1259
36	0.2918	0.5745	0.6422	0.0403	0.3103	0.1446
37	0.3134	0.6171	0.6897	0.0433	0.3333	0.1553
38	0.3198	0.6297	0.7038	0.0442	0.3401	0.1584
39	0.3406	0.6706	0.7495	0.0471	0.3622	0.1687
40	0.2918	0.5745	0.6422	0.0403	0.3103	0.1446
41	0.3929	0.7736	0.8646	0.0543	0.4179	0.1946
42	0.2957	0.5823	0.6508	0.0409	0.3145	0.1465
43	0.2326	0.4579	0.5118	0.0321	0.2474	0.1152
44	0.1809	0.3563	0.3982	0.0250	0.1924	0.0896
45	0.2619	0.5157	0.5764	0.0362	0.2786	0.1298
46	0.2989	0.5886	0.6579	0.0413	0.3179	0.1481
47	0.3198	0.6297	0.7038	0.0442	0.3401	0.1584
48	0.3274	0.6446	0.7205	0.0452	0.3482	0.1622
49	0.3198	0.6297	0.7038	0.0442	0.3401	0.1584
50	0.2989	0.5886	0.6579	0.0413	0.3179	0.1481

Notes

1. Control Dummy1 thru Dummy44 (i = 7 thru i = 50) not shown.
2. Unit assignment costs for Dummy1 thru Dummy44 are zero.