

Fall 1-31-1995

## Catalytic oxidation of trichloroethylene over 5% [alpha]-Fe<sub>2</sub>O<sub>3</sub>/[gamma]-Alumina on a honeycomb monolith

Jeongho Han  
*New Jersey Institute of Technology*

Follow this and additional works at: <https://digitalcommons.njit.edu/theses>



Part of the [Environmental Sciences Commons](#)

---

### Recommended Citation

Han, Jeongho, "Catalytic oxidation of trichloroethylene over 5% [alpha]-Fe<sub>2</sub>O<sub>3</sub>/[gamma]-Alumina on a honeycomb monolith" (1995). *Theses*. 1188.  
<https://digitalcommons.njit.edu/theses/1188>

This Thesis is brought to you for free and open access by the Electronic Theses and Dissertations at Digital Commons @ NJIT. It has been accepted for inclusion in Theses by an authorized administrator of Digital Commons @ NJIT. For more information, please contact [digitalcommons@njit.edu](mailto:digitalcommons@njit.edu).

## **Copyright Warning & Restrictions**

The copyright law of the United States (Title 17, United States Code) governs the making of photocopies or other reproductions of copyrighted material.

Under certain conditions specified in the law, libraries and archives are authorized to furnish a photocopy or other reproduction. One of these specified conditions is that the photocopy or reproduction is not to be “used for any purpose other than private study, scholarship, or research.” If a user makes a request for, or later uses, a photocopy or reproduction for purposes in excess of “fair use” that user may be liable for copyright infringement,

This institution reserves the right to refuse to accept a copying order if, in its judgment, fulfillment of the order would involve violation of copyright law.

**Please Note: The author retains the copyright while the New Jersey Institute of Technology reserves the right to distribute this thesis or dissertation**

Printing note: If you do not wish to print this page, then select “Pages from: first page # to: last page #” on the print dialog screen

The Van Houten library has removed some of the personal information and all signatures from the approval page and biographical sketches of theses and dissertations in order to protect the identity of NJIT graduates and faculty.

## ABSTRACT

### CATALYTIC OXIDATION OF TRICHLOROETHYLENE OVER 5% $\alpha$ -Fe<sub>2</sub>O<sub>3</sub>/ $\gamma$ -Al<sub>2</sub>O<sub>3</sub> ON A HONEYCOMB MONOLITH

by  
**Jeongho Han**

This study addresses the ability of iron oxide to catalytically oxidize low concentrations of trichloroethylene (TCE) with air. The catalytic oxidation of trichloroethylene in a tubular reactor system was evaluated experimentally as a function of temperature and space velocity. A gas chromatograph with electron capture and flame ionization detectors was used for quantitative analysis of feed and product streams. X-ray diffraction measurement were used to qualitatively analyze the catalyst. The result indicate that over 99% conversion of 109 ppmv trichloroethylene in air is achieved at 1,490 v/v/hr and 450 °C, and at 21,768 v/v/hr, 550 °C. The major products from the oxidation of trichloroethylene over iron oxide are CO<sub>2</sub>, Cl<sub>2</sub> and HCl, with trace amount of CCl<sub>4</sub>, CHCl<sub>3</sub> and CO at lower temperatures.

**CATALYTIC OXIDATION OF TRICHLOROETHYLENE OVER  
5%  $\alpha$ -Fe<sub>2</sub>O<sub>3</sub>/ $\gamma$ -ALUMINA ON A HONEYCOMB MONOLITH**

by  
**Jeongho Han**

**A Thesis  
Submitted to the Faculty of  
New Jersey Institute of Technology  
in Partial Fulfillment of the Requirement for the Degree of  
Master of Science in Environmental Science**

**Department of Chemical Engineering,  
Chemistry, and Environmental Science  
January 1995**

APPROVAL PAGE

CATALYTIC OXIDATION OF TRICHLOROETHYLENE OVER  
5%  $\alpha$ -Fe<sub>2</sub>O<sub>3</sub>/ $\gamma$ -ALUMINA ON A HONEYCOMB MONOLITH

Jeongho Han

---

Dr. Henry Shaw, Thesis Advisor Date  
Professor of Chemical Engineering and Environmental Science, NJIT

---

Dr. R. Trattner, Committee Member Date  
Associate Chair of Environmental Science and Professor of Chemistry, NJIT

---

William Librizzi, Jr, P.E, Committee Member Date  
Director of Technology Applications, Center for Environmental Engineering &  
Science and Adjunct Professor, NJIT

## BIOGRAPHICAL SKETCH

**Author:** Jeongho Han

**Degree:** Master of Science in Environmental Science

**Date:** January 1995

**Date of Birth:**

**Place of Birth:**

**Undergraduate and Graduate Education:**

- Master of Science in Environmental Science  
New Jersey Institute of Technology, Newark, NJ, 1995
- Bachelor of Science in Biology  
Yonsei University, Seoul, Korea, 1991

**Major:** Environmental Science

This thesis is dedicated to my mother who passed away last year while I was pursuing my master's degree at N.J.I.T. My success with the completion of this thesis is also her success.



## ACKNOWLEDGMENT

I wish to express my sincere appreciation to my advisor, professor Henry Shaw for his guidance, encouragement, and enlightened discussions and support throughout this research.

Special thanks are given to Dr. Robert J. Farrauto for his significant guidance and help in developing experimental approach and for his advise on catalysis. Thanks to Dr. Richard Trattner and Mr. William Librizzi for serving as members of the committee.

I also wish to express appreciation to Dr. James Grow and Clint Brockway for encouragement and kindness during this research and for testing my catalyst.

I wish to express my appreciation to Yi Wang and Tai-Chiang Yu who are members of Catalytic Oxidation Laboratory for timely suggestions and help on catalysis research. Finally, I would like to thank NJIT and the Otto York Environmental Engineering and Science Research Center for giving me the opportunity to obtain this advanced degree.

## TABLE OF CONTENTS

Chapters	Page
1 INTRODUCTION.....	1
2 BACKGROUND.....	4
2.1 Review of the Literature.....	4
2.2 Basic Principles of Catalysis.....	9
2.2.1 General Description of a Catalyst.....	9
2.2.2 Catalytic Processes and Kinetic Characterization.....	9
2.2.3 Catalytic Deactivation.....	11
2.3 Catalyst Synthesis.....	11
2.3.1 Impregnation.....	11
2.3.2 Incipient Wetness or Capillary Impregnation.....	13
2.3.3 Fixing the Active Component.....	13
2.3.4 Drying.....	14
2.3.5 Calcination.....	14
3 EXPERIMENTAL APPROACH.....	16
3.1 Catalytic Material.....	16
3.2 Experimental Apparatus.....	16
3.3 Instrumental Analysis.....	19
3.4 Quantitative Analysis for Testing Catalyst.....	24
3.4.1 Basic Principles.....	25
3.4.2 Procedure.....	26
4 RESULT AND DISCUSSION.....	27
4.1 Catalyst Synthesis.....	27
4.1.1 Impregnation.....	27

**TABLE OF CONTENTS**  
(Continued)

<b>Chapter</b>	<b>Page</b>
4.1.2 Incipient Wetness or Capillary Impregnation.....	27
4.1.3 Fixing the Active Component.....	28
4.1.4 Drying.....	29
4.1.5 Calcination.....	29
4.1.6 Testing the Catalyst.....	29
4.2 Catalytic Oxidation of TCE over Powdered 5% $\alpha$ -Fe <sub>2</sub> O <sub>3</sub> / $\gamma$ -Al <sub>2</sub> O <sub>3</sub> .....	34
4.2.1 Catalyst and Space Velocity.....	34
4.2.2 Feed Concentration of TCE.....	34
4.2.3 The Effect of Temperature on TCE Oxidation.....	34
4.2.4 The Effect of Space Velocity on TCE Oxidation.....	35
4.2.5 Product Distribution of TCE Oxidation over Powdered 5% $\alpha$ -Fe <sub>2</sub> O <sub>3</sub> / $\gamma$ -Al <sub>2</sub> O <sub>3</sub> .....	36
4.3 Catalytic Oxidation of TCE over 5% $\alpha$ -Fe <sub>2</sub> O <sub>3</sub> / $\gamma$ -Al <sub>2</sub> O <sub>3</sub> /monolith .....	38
4.3.1 Catalyst and Space Velocity.....	38
4.3.2 Feed Concentration of TCE.....	38
4.3.3 The Effect of Temperature on TCE Oxidation.....	38
4.3.4 The Effect of Space Velocity on TCE Oxidation.....	39
4.3.5 Kinetic studies of TCE Oxidation.....	40
4.3.6 Product Distribution and Material Balance of TCE Oxidation over 5% $\alpha$ -Fe <sub>2</sub> O <sub>3</sub> / $\gamma$ -Al <sub>2</sub> O <sub>3</sub> .....	42
CONCLUSIONS.....	44
APPENDIXES.....	46
REFERENCES.....	55

## LIST OF TABLES

Tables	Page
1. Bond Energies of Catalytic Materials.....	6
2. Molecular weight of Catalytic Materials.....	28
3. Product Distribute of TCE Oxidation over Powdered 5% $\alpha$ -Fe <sub>2</sub> O <sub>3</sub> / $\gamma$ -Al <sub>2</sub> O <sub>3</sub> .....	36
4. Materials Balance of TCE Oxidation over 5% $\alpha$ -Fe <sub>2</sub> O <sub>3</sub> / $\gamma$ -Al <sub>2</sub> O <sub>3</sub> /monolith.....	42
5. Comparison Between Xu's and this Research.....	45
A 1. Product Distribute of TCE Oxidation over Powdered 5% $\alpha$ -Fe <sub>2</sub> O <sub>3</sub> / $\gamma$ -Al <sub>2</sub> O <sub>3</sub> at 7,369 v/v/hr.....	50
A 2. Product Distribute of TCE Oxidation over Powdered 5% $\alpha$ -Fe <sub>2</sub> O <sub>3</sub> / $\gamma$ -Al <sub>2</sub> O <sub>3</sub> at 1,453 v/v/hr.....	50

## LIST OF FIGURES

Figures	Page
1. Arrhenius Equation in Catalytic Process.....	12
2. Conversion of Reactant as a Function of Temperature Showing Rate Controlling Regions.....	12
3. Schematic of Catalytic Oxidation System.....	17
4. Calibration Curve of Chlorine Gas.....	20
5. Apparatus of Potentiometric Titration.....	21
6. Nickel Hydrogenation Catalyst System.....	22
7. Calibration Curve of TCE.....	23
8. Peak of Resolution Time of Chlorinated hydrocarbons on ECD.....	facing 24
9. Peak of Resolution Time of CO, CH <sub>4</sub> and CO <sub>2</sub> on FID.....	facing 24
10. X-ray diffraction crystallography of Pure Fe <sub>2</sub> O <sub>3</sub> .....	30
11. X-ray Diffraction Crystallography of Pure Al <sub>2</sub> O <sub>3</sub> .....	31
12. X-ray Dffraction Crystallography of Catalyst before Calcination.....	32
13. X-ray Diffraction Crystallography of Catalyst after Calcination.....	33
14. Conversion of 109 ppm of TCE as a Function of Temperature over Powdered 5% α-Fe <sub>2</sub> O <sub>3</sub> / γ-Al <sub>2</sub> O <sub>3</sub> at 13,250v/v/hr.....	35
15. Catalytic Oxidation of TCE over Powdered 5% α-Fe <sub>2</sub> O <sub>3</sub> / γ-Al <sub>2</sub> O <sub>3</sub> at 13,250v/v/hr.....	37
16. Conversion of 109 ppm of TCE as a Function of Temperature over α-Fe <sub>2</sub> O <sub>3</sub> / γ-Al <sub>2</sub> O <sub>3</sub> /monolith at 21768v/v/hr.....	39
17. First Order Rate Constant for TCE Oxidation.....	41
18. Arrhenius Plot of First Order Rate Constant for TCE Oxidation.....	41
19. Catalytic Oxidation of TCE over 5% α-Fe <sub>2</sub> O <sub>3</sub> / γ-Al <sub>2</sub> O <sub>3</sub> /monolith at 21768v/v/hr.....	43

**LIST OF FIGURES**  
(Continued)

A 1. X-ray Diffraction Crystallography of Catalyst .....	47
A 2. X-ray Diffraction Crystallography of Catalyst .....	48
A 3. Conversion of 109 ppm of TCE as a Function of Temperature over Powdered 5% $\alpha$ -Fe <sub>2</sub> O <sub>3</sub> / $\gamma$ -Al <sub>2</sub> O <sub>3</sub> at 7,365 v/v/hr.....	51
A 4. Conversion of 109 ppm of TCE as a Function of Temperature over Powdered 5% $\alpha$ -Fe <sub>2</sub> O <sub>3</sub> / $\gamma$ -Al <sub>2</sub> O <sub>3</sub> at 1,453 v/v/hr.....	52
A 5. Catalytic Oxidation of TCE over 5% $\alpha$ -Fe <sub>2</sub> O <sub>3</sub> / $\gamma$ -Al <sub>2</sub> O <sub>3</sub> /monolith at 1,490 v/v/hr.....	54

## CHAPTER 1

### INTRODUCTION

Many organic chemical processes use organic solvents to dissolve feedstocks in order to promote reaction. Very often these solvents are chlorocarbons because of their stability and ability to dissolve different functional groups. A byproduct of these processes is a often a mixture of hydrocarbons contaminated with halogen containing compounds. Hydrocarbons contaminated with halogen compounds can not be disposed without treatment. Usually one condenses these compounds and recycles them back into the process. However, when their concentration is very small, then other means of treatment are needed. These compounds can be destroyed by incineration, removed by scrubbing, or adsorption. Incineration is the most frequently used method to destroys these compounds. They are combusted at temperatures greater than 1,000 °C or by catalytic oxidation at temperature between 300 and 550 °C (Bonacci , et al., 1988)

Thermal incinerator (non catalytic) requires high temperatures, with concurrent high fuel costs and the potential for formation of acid gases such as  $\text{NO}_x$  . Frequently, more highly chlorinated, and hence, more toxic products than the starting materials are formed. Thermal incinerators are widely used even though their operation also causes other problems. It need expensive high-temperature materials. Its higher fuel costs often make them less desirable than catalytic incinerators for destroying trace quantities of these hydrocarbons contaminated with halogenated compounds.

Catalytic oxidation has been in use for over 25 years and is considered a proven method for treating hydrocarbons. However, the destruction of hydrocarbons contaminated with halogenated compounds needs to be investigated because the halogenated compounds tend to poison most catalysts. Furthermore, the halogenated compounds need to be reduced to the level mandated by the Clean Air Act. Current

research continues to find ways to increase the effectiveness of catalytic oxidation and to extend its use to more demanding applications.

Hydrocarbons contaminated with chlorocarbon compounds are currently destroyed by catalysts, that are supported on ceramic honeycombs, although some companies use metal substrates in place of traditional ceramic supports (Heck and Farrauto, 1994). Catalysts used for the destruction of VOCs lose activity when char and particulate in the gas cover catalytic sites or when contaminants interact with the catalyst. Activity can be regained by thermal, physical, or chemical regeneration (Jennings, 1985). Thermal regeneration burns off char or decomposes organic films. Physical treatment can be used to clean catalytic surfaces by pushing with compressed air or washing with water in order to remove dust and other particulates. Chemical treatment uses mild acid, bases, or chelating solutions to remove contaminants. With periodic regeneration, catalysts can be used for up to 12 years or even longer in specific applications (Heck and Farrauto 1994).

Several companies have commercialized new oxidation catalysts. Allied-Signal reported success in catalytically oxidizing chlorinated hydrocarbons, but has not released details of the process. The Allied-Signal patent cites platinum, vanadium pentoxide, and titanium dioxide as major catalyst components (Lester, G.R. 1990 patent BOIJ23/64, No A62D3100).

Photochemical oxidation of trichloroethylene to hydrochloric acid and carbon dioxide using titanium dioxide catalysts irradiated with ultraviolet light. However, more research is needed to determine the commercial feasibility of this process.

A catalyst overall effectiveness depends on the selectivity to desirable products for practical detoxification. Previous research in the heterogeneous catalytic oxidation of low concentrations of chlorinated hydrocarbons with air has focused on identifying highly active catalysts and final reaction products at temperatures high enough to achieve essentially complete oxidation. In general, reaction condition are chosen that result in complete oxidation to  $H_2O$ ,  $CO_2$  and  $HCl$ .



Although chlorinated hydrocarbons in waste water are usually removed by air-stripping (air is forced through the waste water to pick up the hydrocarbons), a competitive approach is to treat them directly in the liquid phase. A catalytic hydrodechlorination method that yields chloride-free hydrocarbons and hydrochloric acid is being developed by Suphan Kovenklioglu (1992) at Stevens Institute of Technology in collaboration with Engelhard. Kovenklioglu and coworkers use precious-metal catalysts supported on carbon carriers to gain high conversion efficiencies and selectivities at room temperature in both batch and trickle-bed reactors (Kovenklioglu, et al., 1992)

This research addresses some of the key issues necessary to move catalytic incineration closer to commercial application. The key items being studied are: (1) application of transition metal oxide catalytic material such as 5%  $\alpha$ -Fe<sub>2</sub>O<sub>3</sub>/ $\gamma$ -Al<sub>2</sub>O<sub>3</sub>/monolith to oxidize chlorinated compounds; (2) determine how the synthesis of transition metal oxide catalysts affect activity; and (3) comparison with previous research on powdered Fe<sub>2</sub>O<sub>3</sub> catalysts. As will be pointed out in the background, certain transition metal oxide form weak bonds with chlorides and are believed good candidates for chlorocarbon destruction. Furthermore, the research should examine the pathway for catalytic oxidation of hydrocarbons and chlorocarbons. There are very few studies that examine the reaction pathway for oxidation of compound that contain hydrocarbons, particularly at temperatures below 600 °C. This information is needed to optimize catalyst formulations and establish the data base for the design of commercial reactors.

## CHAPTER 2

### BACKGROUND

#### 2.1 Review of the Literature

Hydrocarbons contaminated with halogen compounds are emitted from many industrial processes. These compounds are often found in trace amounts and are best disposed of by incineration. One such example involves the disposal of chlorinated hydrocarbons used commercially as stripping and dry cleaning solvents, transformer fluids, etc. These materials can become toxic wastes for which cost effective and environmentally sound methods of disposal are being sought. Incineration provides an option which can be applied to a wide range of such wastes. Thermal incineration requires high temperatures, with concurrent high fuel costs and the potential for formation of acid gases such as  $\text{NO}_x$ . Frequently, more highly chlorinated, and hence, more toxic products than the starting materials are formed. Use of a catalytic approach result in lower temperatures, less toxic products and greater flexibility when compared to homogeneous thermal processes.

Subbanna, et al., (1988) studied various catalytic materials and their activities and selectivities towards incinerating polychlorinated biphenyls (PCB). The results show significant performance differences between catalysts. For example,  $\text{Cr}_2\text{O}_3$  converted 69% of the PCB's at 873 K, but yield of oxidized carbon was only 50%. An automotive catalytic converter composed of Pt and Pd, destroyed 87% of the PCB's with the yield of carbon oxides reaching about at 76%. Clearly, a substantial amount of oxychlorination occurs over these catalysts. An explanation for this observation could be offered by appealing to a Mars-van Krevelen mechanism (Mars-van Krevelen, 1954) based on chlorides rather than oxides. This mechanism is consistent with the following two steps:

1. A reaction takes place between the catalytic oxide or chloride, and the hydrocarbon. The hydrocarbon is oxidized and the surface oxide or chloride is reduced.
2. The reduced oxide reacts with O<sub>2</sub> from the air or with the chlorocarbon, returning to its initial state as an oxide or becoming a chloride. The surface component directly responsible for the oxidation is generally assumed to be the O<sup>2-</sup> ion, or Cl<sup>-</sup> ion.

The Mars-van Krevelen mechanism led Sachtler and de Boer (1965) to postulate that the tendency of an oxide to donate its oxygen should be of major importance in determining whether it is a selective oxidation catalyst. If reduction of the oxide is easy (i.e., if the enthalpy of dissociation is small), then O can easily be donated to a molecule from the gas phase. Under these conditions, the catalyst is expected to be active and non selective. On the other hand, if it is difficult to dissociate O<sub>2</sub> because the metal-oxygen bond is strong, then the oxide is expected to have low catalytic activity. In the intermediate range, the oxide might be moderately active and selective.

Simmons, et al., (1968) considered the temperature at which 50 % of the reactants are converted into CO<sub>2</sub> + CO at a particular set of flow conditions to be a characteristic measure of the activity of a catalyst. This measure allows a convenient comparison of the various metal oxide catalysts. Their data show that the temperature for 50 percent conversion to CO<sub>2</sub> + CO increase in roughly linear fashion with the heat of reaction Q<sub>o</sub>, defined as:

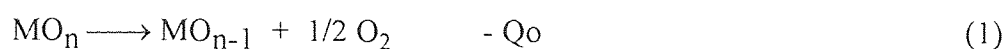

The corresponding equation for chlorination is:

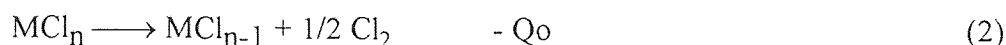

A comparison of equation 1 for oxidation with chlorination in equation 2 is provided in Table 1 by Shaw, 1993.

According to this mechanism, one would expect MnO<sub>2</sub>, PdO, and V<sub>2</sub>O<sub>5</sub> to be among the best metal oxides for destruction of hydrocarbons and possibly chlorocarbons. It is important to note that Cu and Fe catalysts, which have particularly good

oxychlorination activity are among those having the lowest metal chloride bond energies (Satterfield,1990)

**Table 1** Bond Energies of Catalytic Materials (Shaw, 1993)

	Equation 1		Equation 2
	M-O, kcal/mol		M-Cl, kcal/mol
$\text{Co}_3\text{O}_4$	38	$\text{Co}_2\text{Cl}_5$	28
$\text{Cr}_2\text{O}_3$	NA	$\text{CrCl}_3$	40
$\text{CuO}$	34	$\text{CuCl}_2$	17
$\text{Fe}_2\text{O}_3$	54	$\text{FeCl}_3$	15
$\text{MnO}_2$	17	$\text{MnCl}_4$	NA
$\text{NiO}$	58	$\text{NiCl}_2$	38
$\text{PdO}$	20	$\text{PdCl}_2$	23
$\text{SnO}_2$	70	$\text{SnCl}_4$	23
$\text{TiO}_2$	69	$\text{TiCl}_4$	51
$\text{V}_2\text{O}_5$	29	$\text{VCl}_5$	29
$\text{ZnO}$	83	$\text{ZnCl}_2$	50

NA = Not Available

Yao (1984) looked at CuO as an automotive exhaust catalyst for ethanol oxidation. He evaluated CuO catalysts using a simulated exhaust gas of 1%  $\text{O}_2$  and 0.14% ethanol (in helium).  $\text{CuO}/\gamma\text{-Al}_2\text{O}_3$  had the highest activity, as measured by the lowest temperature required to produce no detectable ethanol in the exit gas. Copper catalysts are also subject to deactivation by chlorine. Ostrovskii, et al, (1987) (as reported by Satterfield, 1990) discovered that deactivation was irreversible and was due to interaction of Cu with chlorine compounds. Earlier work has reported extensively on the characteristics of the

Deacon process ( $\text{HCl} + \text{O}_2 = \text{Cl}_2 + \text{H}_2\text{O}$ ), where copper-based catalysts are extensively deactivated by volatilization of  $\text{CuCl}_2$  at the temperatures employed, normally around 600 °C (Satterfield, 1990).

Some studies have involved noble metal catalysts to treat chlorinated hydrocarbon compounds. U.S. patent 1,485,375 (Bond, 1973) showed that 0.8 to 1.5 wt % Pt on  $\gamma\text{-Al}_2\text{O}_3$  catalysts are effective in treating a number of chlorinated compounds, such as  $\text{CH}_2\text{Cl}_2$ ,  $\text{CCl}_4$ ,  $\text{C}_2\text{H}_2\text{Cl}_2$ ,  $\text{C}_2\text{HCl}_3$ ,  $\text{C}_2\text{Cl}_4$  and have good performance in the presence of propane. The percent of destruction of chlorinated compounds is above 95% but the selectivity to HCl was not investigated.

Pope, et al., (1978) studied the oxidation of 1,1,1-trichloroethane in a mixture of gases over a platinum-honeycomb catalyst. They compared the destruction efficiency of a  $\text{Co}_3\text{O}_4$  catalyst with a Pt catalyst. The  $\text{Co}_3\text{O}_4$  catalyst was observed to be the more effective in the presence of chlorinated fuels. Huang and Prefferle (1989) showed that a  $\text{Cr}_2\text{O}_3/\text{Co}_3\text{O}_4$  binary catalyst performed better than a Pt catalyst in the catalytic oxidation of  $\text{CH}_3\text{Cl}$  and  $\text{CH}_2\text{Cl}_2$  in the presence of propane. The product distribution as a function of temperature was not investigated.

Some investigators evaluated transition metal oxides catalysts on supports. A chromium oxide impregnated catalyst on a support was used in the oxidation of chlorinated compounds which treated  $\text{CH}_3\text{Cl}$  (Senkan, et al., 1986), 1,1-dichloroethane (Ramanathan, et al., 1989), hexachlorobenzene and hexachlorobutadiene (Johnston, 1976). It was shown that  $\text{Cr}_2\text{O}_3$  catalysts have good activity for chlorinated compounds destruction. In a study by Ramanathan, et al., (1989), the selectivity to chlorine from catalytic oxidation of 1,1-dichloroethane was determined to be 50% at 500 °C.

Young (1982) investigated the oxidation of methylene chloride over a commercial 12.5 wt % chromia/alumina catalyst. A significant increase in CO content and decrease in  $\text{CO}_2$  content, of the exit gas over time, through this is not related to any observable change in catalyst composition, e.g., halogen or carbon disposition on the catalyst. It is

postulated, however, that chloride or perchlorate formation may occur on the catalyst. The addition of water inhibited the formation of  $\text{Cl}_2$  and heavier (than methylene chloride) chlorinated hydrocarbons which were observed in the absence of added water vapor in the inlet gas. However, the addition of water, by itself, does not affect selectivity to oxides of carbon,  $\text{CO} + \text{CO}_2$ . The oxidation of a series of chlorinated ethylenes on 12.5 wt %  $\text{Cr}_2\text{O}_3$ /alumina and  $\text{Cr}_2\text{O}_3$ /silica (chromia content not given) among other catalyst. On the chromia/alumina catalyst, the formation of chlorinated hydrocarbon polymers was observed both downstream of the catalyst and presumably on the catalyst as well in the oxidation of trichloroethylene. This is said to be formed by the reaction of  $\text{Cl}_2$  formed in the oxidation reaction with an undefined "chlorinated trichloroethylene." The addition of water to the inlet gas increased both the conversion and  $\text{CO}_2$  yield and produced less polymers. Further increase in water content of the inlet gas (resulting in a hydrogen/chlorine atomic ratio of 2.94) caused essentially complete conversion and no polymer formation (Young, P.W. ,1982)

Hydrated nickel oxides, manganese oxides, cobalt oxides (Lavanish, et al., 1976; Sare, et al., 1977) and titania catalysts (Tanguay, 1989) were evaluated for the catalytic oxidation of C2-C4 halogenated hydrocarbons and dichloromethane. Conversion of 45 to 90 percent were obtain for vinyl chloride (VCM), vinylidene chloride (VDCM) and trichloroethane over the nickel oxides (II) and (II and III). At temperature over 450 °C, nickel oxide catalysts started to deactivate by thermal sintering. For an initial concentration of 46.5 ppm of VCM or VDCM at 107 °C, Tanguay showed that 99% conversion was obtained with the cobalt oxide (II) catalyst. Cobalt oxides (II) catalysts deactivated by reacting with  $\text{Al}_2\text{O}_3$  support forming  $\text{CoAl}_2\text{O}_4$  at temperature over 850 °C. The destruction of  $\text{CH}_2\text{Cl}_2$  on titania catalyst showed poor activity.

## 2.2 Basic Principles of Catalysis

### 2.2.1 General Description of a Catalyst

The basic concept of a catalyst is that of a substance that increases the rate of reaction toward equilibrium without being appreciably consumed in the process. A catalyst cannot change the ultimate equilibrium determined by thermodynamics; its role is to accelerate the rate of approach to equilibrium. Many commercial heterogeneous catalysts are composed of an active material and a support. The active component is normally a metal or metal oxide, and the support is a ceramic or metal monolith. Molecules vary in size and chemical structure. So, different catalysts are necessary to promote different reactions. The optimization of a catalyst is specific for each reaction and requires selection of appropriate operating condition. Therefore, determination of performance of a catalyst is dependent on empirical results.

### 2.2.2 Catalytic Processes and Kinetic Characterization

In a catalytic process, reactants must interact with "active site" on the catalyst, the term "active site" is thought to be that site (or sites) on the catalyst surface in which chemisorption and reaction occur. Basically, a catalytic process includes the following steps (Augustine, 1988; Du, 1990) :

1. Bulk diffusion: reactants must pass through stagnant film from the gas or liquid phase.
2. Pore diffusion: reactants diffuse or are transported through pore structures to active sites.
3. Chemisorption: a reactant chemically adsorbs on active sites, i.e., by bonding.
4. Chemical reaction: a reactant is converted to a product on the active sites.
5. Desorption: products desorb from the active sites.
6. Product diffusion: products diffuse through pores from the active sites.

7. Product diffusion: products diffuse through the film to the bulk gas or liquid phase.

Steps 1 and 7 are controlled by mass transfer limitations; steps 2 and 6 are controlled by pore diffusion limitations; and steps 3, 4 and 5 are controlled by chemical reaction limitations. The physical and chemical properties of catalysts and operating conditions that control the rate of reaction are carefully chosen.

Much research is required to optimize the properties of a catalyst and the conditions for its practical use. The effort of rate limiting phenomena is correlated with the Arrhenius expression from which activation energies are determined.

A general plot depicting the three rate regimes in catalysis is shown in Figure 1. Figure 2 illustrates a conversion versus temperature profile. The relationship used in plotting Figure 1, normally in  $k$  versus  $1/T$ , is obtained from the Arrhenius expression as follows:

$$k = A \exp(-E_a/RT)$$

$$\ln k = \ln A + (-E_a/R) * (1/T)$$

Where,  $k$  = rate constant,

$A$  = preexponential factor,

$E_a$  = activation energy, kcal/mole,

$R$  = gas constant, kcal/mole \* K, and

$T$  = absolute temperature, K.

The calculation of the activation energy,  $E_a$ , from the slope of the Arrhenius plot allows an assessment of the rate limiting step. From Figures 1 or 2, it is evident that reactions controlled by chemical kinetics are most sensitive to temperature, while mass transfer controlled reactions are essentially temperature independent.



### **2.2.3 Catalyst Deactivation**

A catalyst may lose its activity or its selectivity for a wide variety of reasons. The causes may be grouped loosely into:

1. Poisoning
2. Fouling
3. Reduction of active area by sintering or migration
4. Loss of active species

A catalyst poison is a chemical present in the feed stream that interferes with the normal operation of the catalyst, reducing its activity. In the oxidation of chlorinated hydrocarbons, a catalyst can be poisoned by chloride. It may poison a metal by forming a surface metal chloride, or it may enhance sintering via the formation of volatile metal chlorides ( Satterfield, 1990). Therefore, development of a chloride tolerant catalyst or additives which can react with the chloride, thus avoiding catalyst poisoning is an important aspect for catalytic oxidation of chlorinated hydrocarbon.

## **2.3 Catalyst Synthesis**

### **2.3.1 Impregnation**

The most common procedure for dispersing catalytic material into a carrier is by impregnating an aqueous solution containing a salt (precursor) of the catalytic element or elements. Most preparations simply involve soaking the carrier in the solution and allowing capillary and electrostatic forces to distribute the salt within the porous network. The salt generation of the cations or anions containing the catalytic element are chosen to be compatible with the surface charge of the carrier to obtain efficient adsorption or in some cases ion exchange ( Heck and Farrauto ,1994).

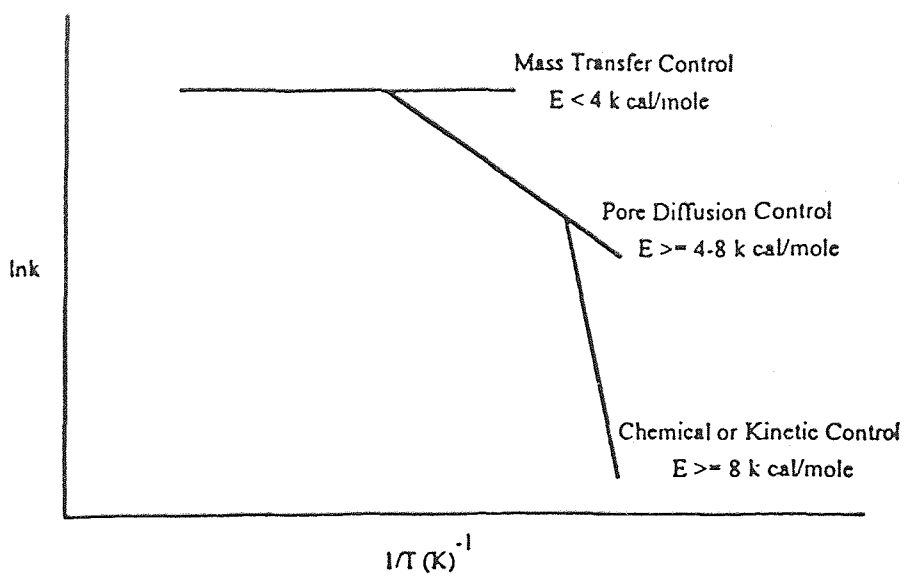

Figure 1 Arrhenius Equation in Catalytic Process (Heck and Farrauto 1994)

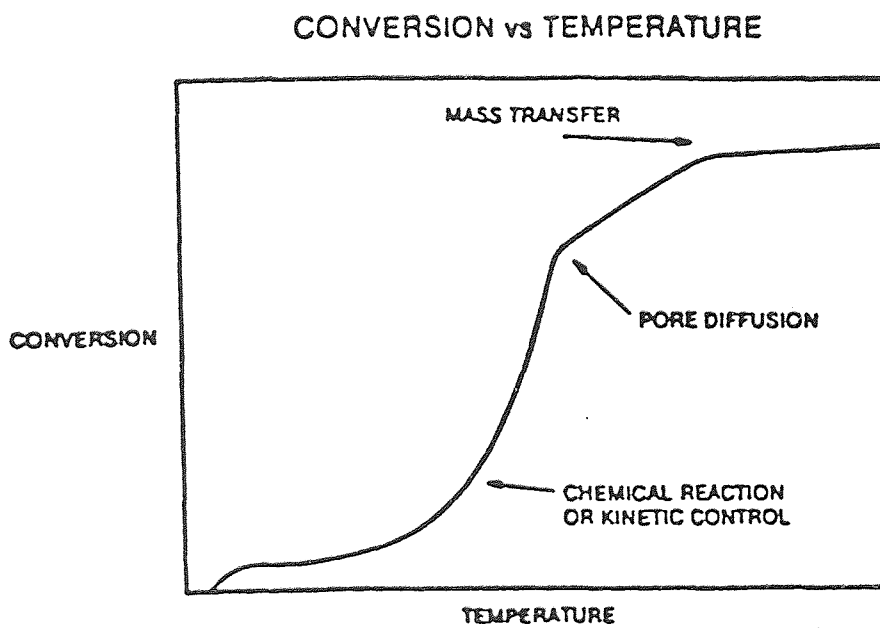

Figure 2 Conversion of Reactant as a Function of Temperature Showing rate controlling regions (Heck and Farrauto, 1994)

### 2.3.2 Incipient Wetness or Capillary Impregnation

The maximum water uptake by the carrier is referred to as the water pore volume. This is determined by slowly adding water to a carrier until it is saturated as evident by the beading of the excess  $H_2O$ . The precursor salt is then dissolved in an amount of water equal to the water pore volume. In this manner, the precise amount of catalytic material is assured to be present in the carrier (Heck and Farrauto, 1994).

### 2.3.3 Fixing the Active Component

Following impregnation it is often desirable to fix the active component so subsequent processing steps such as washing, drying and calcination will not cause significant movement or agglomeration of the well dispersed catalytic precursor materials.

#### 1. Precipitation

The pH of the solution is adjusted to precipitate the catalytic material in the pores of the carrier. For example, by presoaking  $Al_2O_3$  in a solution of  $NH_4OH$  the addition of an acidic Pd salt such as  $Pd(NO_3)_2$  will precipitate hydrated PdO on the surfaces within carrier.

A special case of fixation is when both carrier and catalytic species are co-precipitated simultaneously. For example, a CuO, ZnO,  $Al_2O_3$  methanol synthesis catalyst, can be prepared by adjusting the pH (between about 6 and 8) of a solution containing salts of all three components. This method is commonly used when large amounts of catalytic components, i.e., greater than 15 %, are desired for a particular reaction.

Sulfur compounds such as  $H_2S$  sometimes are used to precipitate and thus, immobilize the catalytic materials. Hydrotreating catalysts composed of CoO and  $MnO_2$  supported on  $Al_2O_3$  are treated with gaseous  $H_2S$  to fix them to the  $Al_2O_3$  surface. These catalysts are then used in hydrodesulfurization of petroleum feeds so exposure to sulfur in the preparation step offers no special poisoning problem. This method, however, is not

generally recommended for other catalysts since the removal of the sulfur compound may not be sufficient to avoid the negative poisoning effects.

## 2. Reduction

The addition of reducing agents such as hydrazine, formic acid, oxalate, and hydrogen are sometimes used to precipitate catalytic materials as metals an example of which is shown below for nickel.

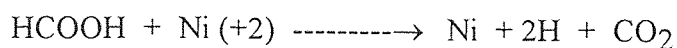

Precious metals such as Pd and Pt can be generated on the internal surface of the catalyst carrier by addition of chemical reducing agents. This method is particularly effective for precious metals because they are easily reduced to their metallic states. The advantage of the reducing agents mentioned above is that upon subsequent heat treatment. They leave no residue to foul the catalyst.

### 2.3.4 Drying

Excess water and other volatile species are removed during drying at about 110 °C for 24 hours.

### 2.3.5 Calcination

This is usually the last step in producing a catalyst. Its purpose is to decompose and volatilize the various salt components not needed in the final catalyst. For inorganic oxides, this is typically done in air at temperatures between 300-500 °C. Catalysts supported on carbon are only dried due to combustibility of the carbon. Great care must be taken to avoid rapid heat up since H<sub>2</sub>O trapped in the micro pores can build up sufficient pressure to crack particulate carriers. Occasionally, high temperature treatments may be carried out in a reducing or neutral environment to avoid oxidizing catalytic metals which could then react with the carrier. Nickel catalysts are used in reducing environments, e.g., steam reforming, hydrogenation, etc. and are less active if they are

calcined in air due to reaction between  $\text{Ni}^{+2}$  and the  $\text{Al}_2\text{O}_3$  surface. High temperature conditions are required to reduce the oxide to the metallic state. Severe conditions such as high temperatures can result in sintering of the carrier and/or the well dispersed Ni crystallites decreasing catalytic surface area.

## CHAPTER 3

### EXPERIMENTAL APPROACH

#### 3.1 Catalyst Materials

The catalyst used in this research were made by using the incipient wetness method. Iron oxide from Aldrich Chemical Co. was used to synthesize the catalyst. The iron oxide specification were:

Iron(III) Oxide,  $\text{Fe}_2\text{O}_3$

-100 mesh

Lot Number X 14439

CAS # 1309-37-1

Density 5.24  $\text{gm}/\text{cm}^3$

Melting Point 1,565  $^\circ\text{C}$

The alumina specification were:

Alumina,  $\text{Al}_2\text{O}_3$

CAS # 1344-28-1

Density 3.970  $\text{gm}/\text{cm}^3$

The monoliths used in these experiments were manufactured by Corning and supplied to us by Engelhard. The monoliths were made out of cordierite and had 400 cells /  $\text{in}^2$ .

#### 3.2 Experimental Apparatus

Catalyst evaluation experiments were conducted in a laboratory scale tubular reactor system as shown in Figure 3. This system consists of a 2.5 cm inside diameter quartz tube reactor (Kontes Scientific Glassware, Inc.) residing in a vertical three zone controlled furnace (Applied Test System, Inc.). The catalyst, consisting of iron oxide on  $\gamma\text{-Al}_2\text{O}_3$

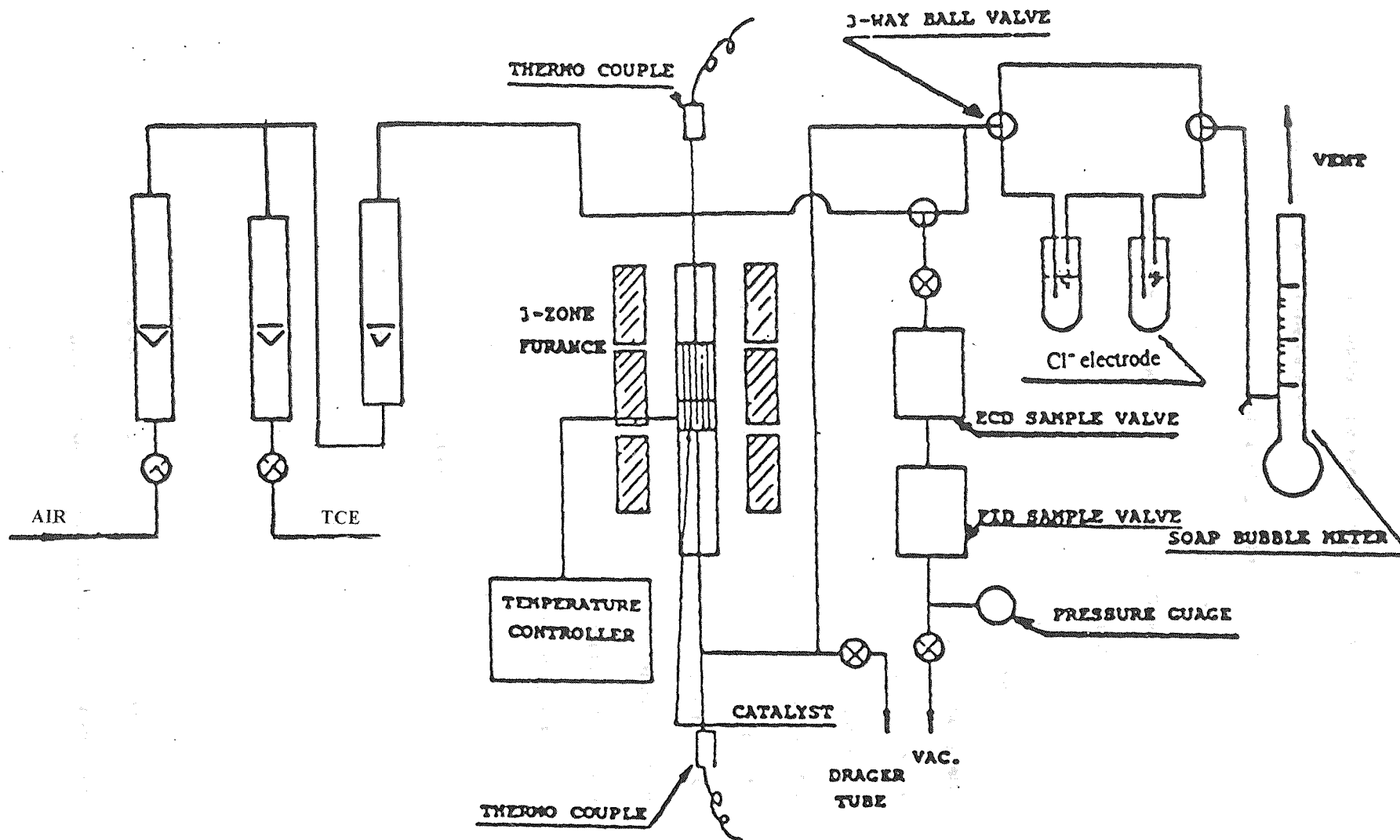

Figure 3 Schematic of catalytic oxidation system

powder or on monolith was placed in the middle zone which was designed to maintain a flat temperature profile over the length of the catalyst.

Approximately 1000 ppmv TCE from a calibrated gas mixture (Matheson) was mixed with the air to lower the concentration to about 100 ppm TCE and fed to the reactor. The concentration of TCE could be changed by varying the flow rate of dilution air. The flow rate of inlet gases were measured with two calibrated rotameter (Aalborg Co.). The range of both rotameter is 0-600 cm<sup>3</sup>/min.

The reactor temperatures was monitored by two 0.16 cm chromel (K-type) thermocouples (Omega Engineering, Inc.) which were inserted in both sides of the quartz tube reactor and place in the center line immediately before and after the catalyst. Since the measured temperatures was sufficiently low, no correction was made for radiation.

Quantitative analysis of reactants and products was conducted chromatographically after individual calibrations of each peaks which include TCE, CO<sub>2</sub> and CO. The concentration of carbon monoxide, carbon dioxide was quantitatively analyzed by gas chromatography (GC) using a nickel hydrogenation catalyst system (Figure 6) to convert these components to methane and measure the methane with a flame ionization detector (FID) and the chlorinated hydrocarbons by gas chromatography (GC) with electron capture detector (ECD) (Griffith 1983). The concentration of chlorine was measured by methyl orange colorimetric method. In addition, the product gas was bubbled through a scrubber to absorb hydrogen chloride and the concentration of chloride ion in the aqueous solution was measured with a chloride ion selective electrode (Boltz 1992) The qualitative analysis used for ascertaining the composition of the catalyst was conducted using x-ray diffraction crystallography.

The calibration and feed gases were purchased from the Matheson Co. and were used directly from cylinders in the experiments. The air which we used as the oxidizing gas was of research grade purity zero air, with less than 5 ppm water and less than 1 ppm hydrocarbons.



### 3.3 Instrumental Analysis

The concentration of chlorine gas was measured by methyl orange colorimetric method. This method was specific for chlorine gas and had no interferences. First, 0.06 g of methyl orange was dissolved in water and diluted to 1 dm<sup>3</sup>. Several dm<sup>3</sup> of pH 2 buffer solution to prevent rapid changing of the color of the solution was also prepared. A mixture containing 5 cm<sup>3</sup> methyl orange solution and 100 cm<sup>3</sup> pH 2 buffer solution was added to the bubblers. Then chlorine gas was bubbled through this solution. The decrease in the methyl orange color was proportional to the concentration of chlorine. The calibration curve for chlorine gas, shown in Figure 4, was made by bubbling purchased standard chlorine gas through the methyl orange solution for different periods of time.

Then the chlorine concentration in the solution was measured by ultraviolet spectrophotometry at a wavelength 515 nm. Since the ultraviolet absorbance is proportional to the color strength of methyl orange solution, the decrease in the ultraviolet absorbance is therefore proportion to the concentration of chlorine. The concentrations of hydrogen chloride were determined by potentiometric titration. The potential of a chloride ion selective electrode (Jenco Co.) was employed to establish the equivalence for titration of HCl. The potentiometric titration for HCl provides concentration of HCl from a direct potentiometric measurement. The potentiometric end point, as shown Figure 5-(a), (b), (c), is widely applicable and provides inherently more accurate data than the corresponding method employing indicators. As shown in Figure 5-(d), the apparatus for a potentiometric titration is relatively simple.

The on-stream analysis was conducted at 45 minute intervals by pulling part of the effluent product stream with a vacuum pump through a six point gas sampling valve, from which it was picked up by the carrier gas to either of the two on-line gas chromatography (Hewlett Packard 5890).

The carbon monoxide, methane and carbon dioxide were separated on a 1/8 inch in diameter by 6 feet long stainless steel column packed with 80/100 mesh Poropak Q and

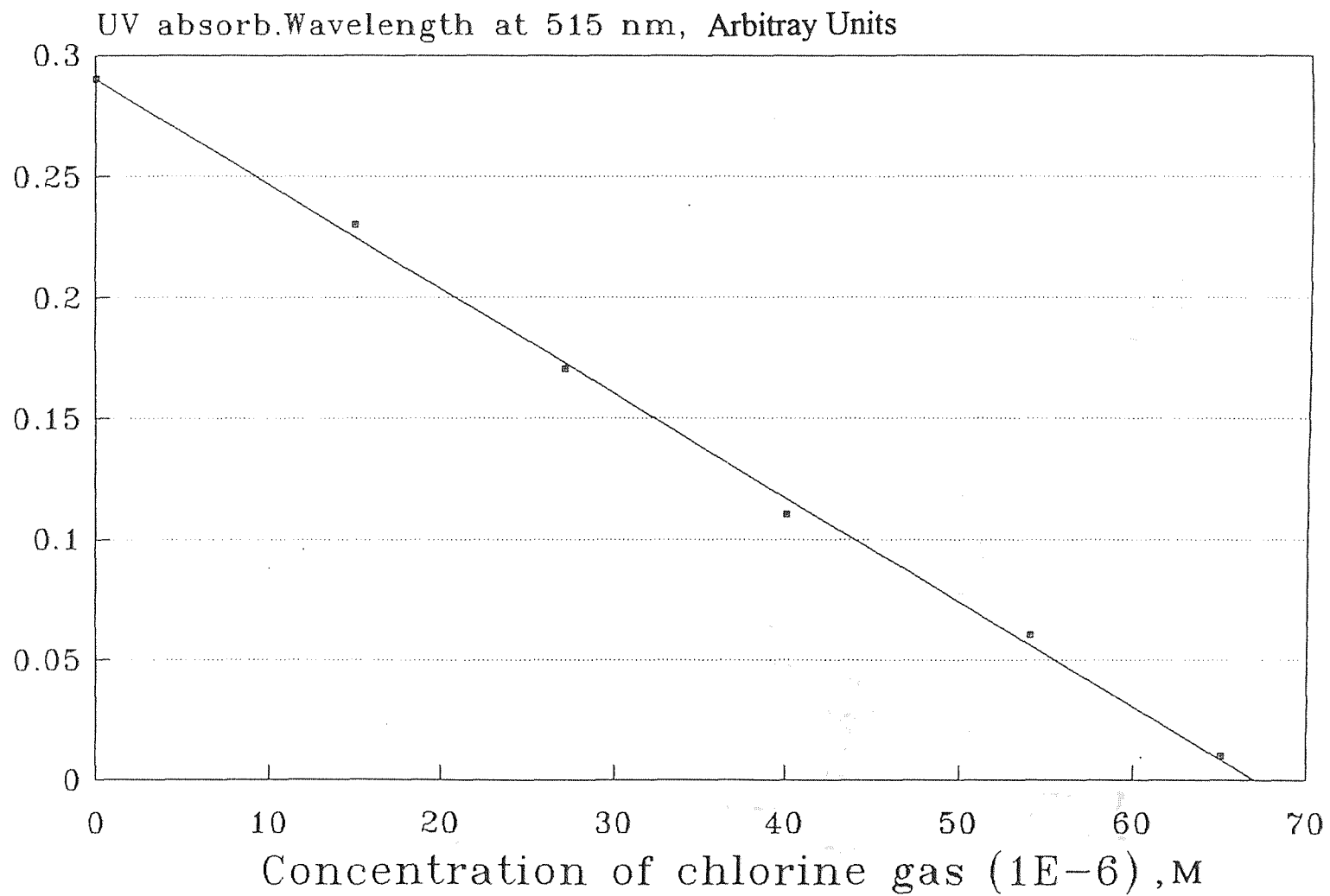
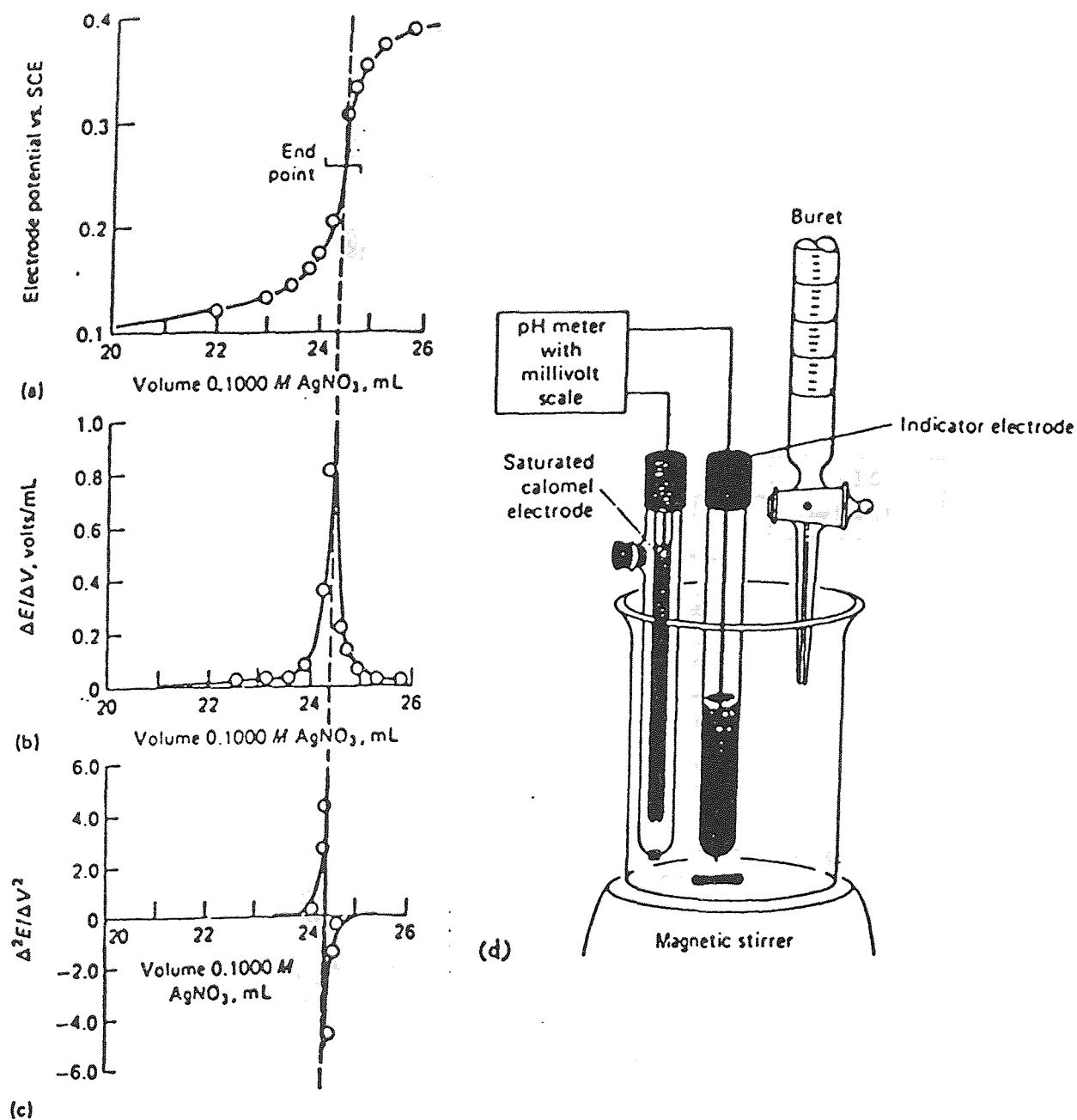

Figure 4 Calibration curve of dissolved chlorine gas



**Figure 5** a) Potentiometric Titration Curve for 2.334 meq of Cl with 0.10 M  $\text{AgNO}_3$   
 b) First Derivative curve c) Second Derivative Curve d) Apparatus for potentiometric titration (Skoog, 1992)

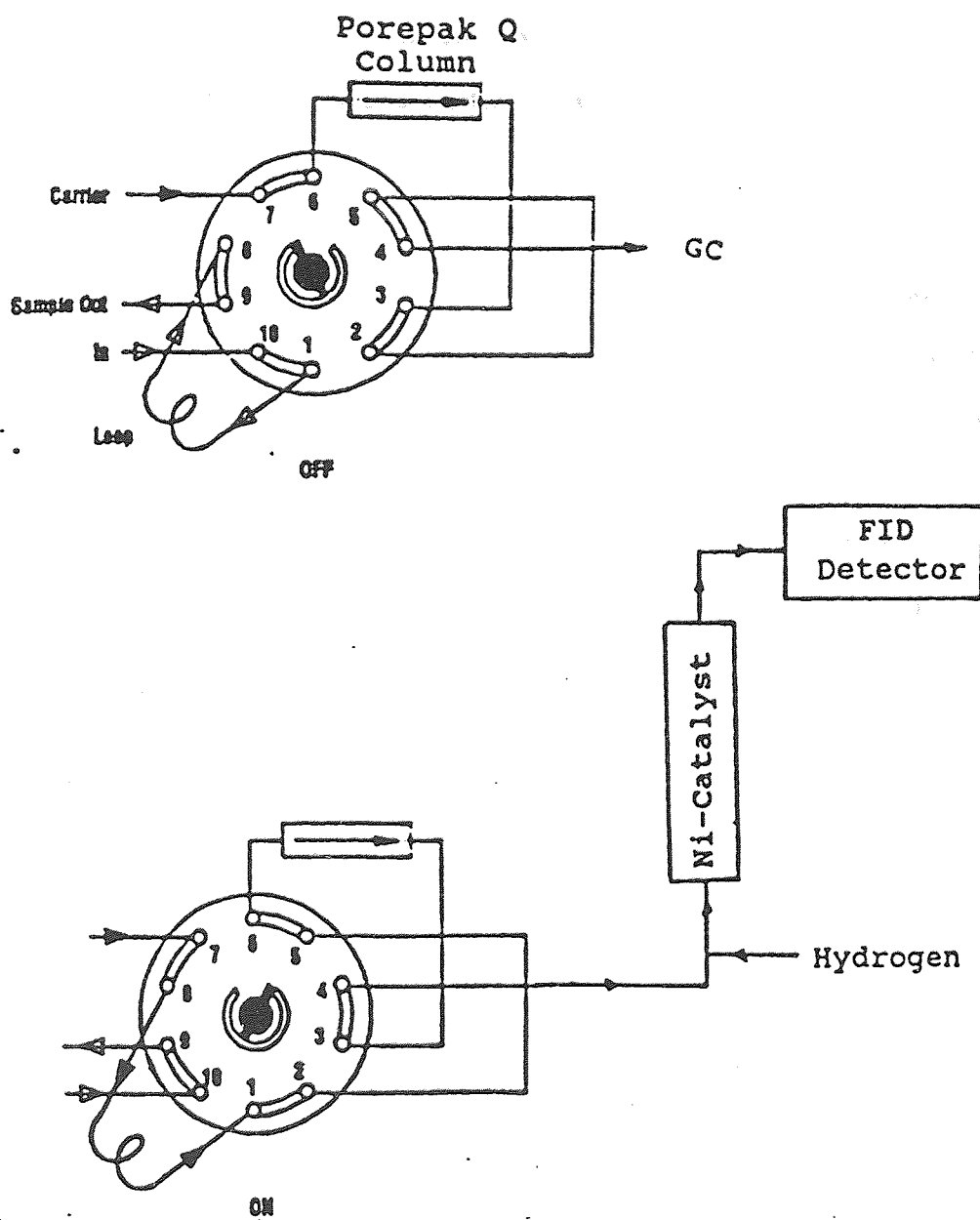
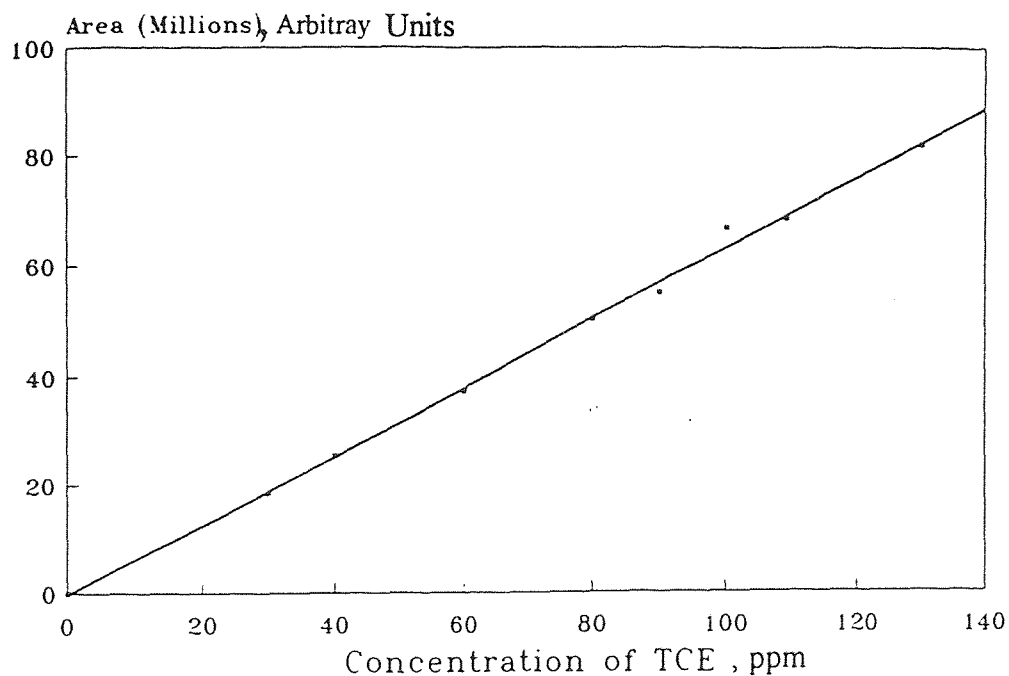

Figure 6 Nickel Hydrogenation Catalyst System  
(Hewlett Packard Application Note 228-92, 1989)

hydrogenated over nickel catalyst system to methane before detection by flame ionization detector (FID). This was done in order to increase the sensitivity for the analysis of the oxides of carbon by orders of magnitude, and thus improve carbon balances. The flow schematic for the nickel hydrogenation catalyst systems is shown Figure 6 . When the ten-point sampling valve is at the off position, the product effluent pass through the sampling loop and discharge to the hood. Once the valve is switched over to the on position, the effluents are carried out by helium from the sampling loop in to the Poropak Q column. The individual peaks are then hydrogenated with hydrogen to methane using the nickel catalyst at 350 °C. Thus, the carbon monoxide, methane and carbon dioxide peaks are detected as methane but recognized based on retention time.

All chlorinated hydrocarbons, carbon dioxide and carbon monoxide concentrations were calibrated with standard gas mixtures purchased from Matheson Co.. The calibration curve of TCE, shown in Figure 7, was made by diluting 1,000 ppmv TCE by a factor of ten lower concentrations with air using a calibrated rotameter.



**Figure 7** Calibration curve of trichloroethylene

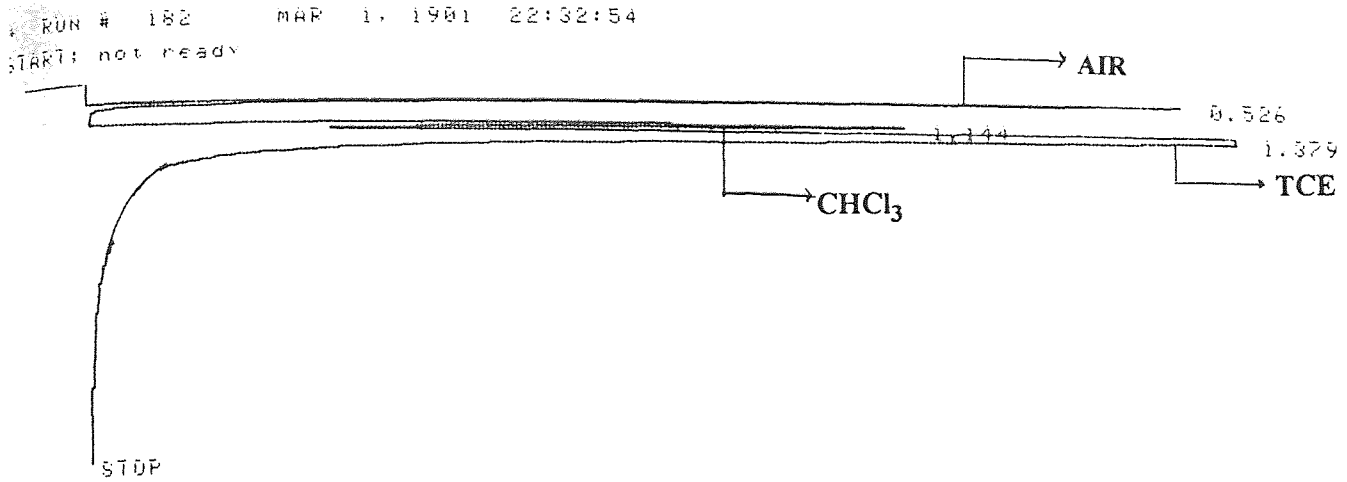

RUN# 182      MAR 1, 1981 22:32:54

AREA%

RT	AREA	TYPE	WIDTH	AREA%
.526	5641242	PB	.048	7.95989
1.144	9835763	PV	.105	12.74962

**Figure 8** Peak Resolution Time of Chlorinated Hydrocarbons with ECD

\* RUN # 154      MAR 30, 1981 00:10:12  
 START: not ready

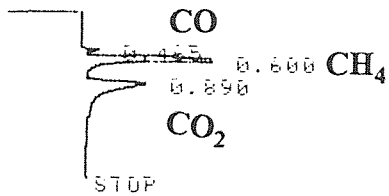

RUN# 154      MAR 30, 1981 00:10:12

AREA%

RT	AREA	TYPE	WIDTH	AREA%
.465	844512	PV	.034	2.60920
.600	16907488	VB	.079	52.23715
.890	14614776	BB	.141	45.15365

TOTAL AREA=3.2367E+07  
 MUL FACTOR=1.0000E+00

**Figure 9** Peak Resolution Time of CO, CH<sub>4</sub> and CO<sub>2</sub> with FID

GC one: for chlorinated hydrocarbons

Column packing material : 2% SE 30 on GAW 80/100

1/8" X 10', ss (Alltech Associates)

Carrier gas: Nitrogen, 30 cm<sup>3</sup>/min

Oven: 40 °C for 4 min, 40 °C-80 °C at 20 °C/min, 80 °C for 10 min

Injector: 150 °C

Detector: ECD 250 °C

Integrator attenuation: 9

GC two: for methane, carbon monoxide, carbon dioxide

Column packing materials: Porapak Q 80/100, 1/8"x6' ss (Hewlett Packard)

Carrier gas: Helium, 20 cm<sup>3</sup>/min

Oven: 40 °C

Injector: 350 °C

Detector: FID 250 °C

Air flow rate: 400 cm<sup>3</sup>/min

Hydrogen flow rate: 35 cm<sup>3</sup>/min

Nickel catalyst reactor: 350 °C

Integrator attenuation: 1

Figures 8 and 9 (facing 24) show the typical peak resolution and retention times for TCE with an ECD and carbon monoxide, carbon dioxide and methane after hydrogenation using a FID.

### **3.4 Qualitative Analysis for Determining Catalyst Structure**

Qualitative analysis for determining catalyst structure was conducted using X-ray diffraction. Diffraction analysis is useful whenever it is necessary to know the particular phases which are present.

The particular advantage of X-ray diffraction analysis is that if the material is crystalline, it discloses the presence of a substance as that substance actually exists in the sample, and not in terms of its constituent chemical elements. For example, if a sample contains the crystalline compound  $A_xB_y$ , the diffraction method will disclose the presence of  $A_xB_y$  as such, in the crystalline state, whereas ordinary chemical analysis would show only the presence of elements A and B. Furthermore, if the sample contained both  $A_xB_y$  and  $A_xB_{2y}$ , both of these compounds would be disclosed by the diffraction method, but chemical analysis would again indicate only the presence of A and B. To consider another example, chemical analysis of a plain carbon steel reveals only the amounts of iron, carbon, manganese, etc., which the steel contains, but gives no information regarding the phases present. Is the steel in question wholly martensitic, does it contain both martensite and austenite, or is it composed only of ferrite and cementite? Questions such as these can be answered by the diffraction method. Another rather obvious application of diffraction analysis is in distinguishing between different allotropic forms of the same substance: solid silica, for example, exist in one amorphous and six crystalline forms, and the diffraction patterns of these seven forms are all different.

### 3.4.1 Basic Principles

The powder pattern of a substance is characteristic of that substance and forms a sort of fingerprint by which the substance may be identified. If we had on hand a collection of diffraction patterns for a great many substances, we could identify an unknown by preparing its diffraction pattern and then locating in our file of known patterns one which matched the pattern of the unknown exactly. The collection of known patterns has to be fairly large, if it is to be at all useful, and then pattern-by-pattern comparison in order to find a matching one becomes out of the question.

What is needed is a system of classifying the known patterns so that one which matches the unknown can be located quickly. Such a system was devised by Hanawalt in



1936 (Cullity, 1980). Any one powder pattern is characterized by a set of line positions and set of relative line intensities  $I$ . But the angular positions of the line depend on the wavelength used, and more fundamental quantity is the spacing  $d$  of the lattice planes forming each line. Hanawalt therefore decided to describe each pattern by listing the  $d$  and  $I$  values of its diffraction lines, and to arrange the known patterns in decreasing values of  $d$  for the strongest line in the pattern. This arrangement made possible a search procedure which would quickly locate the desired pattern. In addition, the problem of solving the pattern was avoided and the method could be used even when the crystal of the structure of the substance concerned was unknown (Cullity, 1980)

### 3.4.2 Procedure

Identification of the unknown begins with obtaining its diffraction pattern. Sample preparation should result in fine grain size and in a minimum of preferred orientation, which can cause relative line intensities to differ markedly from their normal values. Note also that relative line intensities depend to some extent on wavelength; this should be kept in mind if the observed pattern is compared with one in the data file made with a different wavelength. All of the patterns given here were made with Cu  $K\alpha$  radiation using a Demax x-ray diffractometer from Rakagu.

After the pattern of the catalyst was obtained, the plane spacing corresponding to each line on the pattern were calculated and printed by computer controlling the apparatus. Since it was known that  $\alpha$ -Fe<sub>2</sub>O<sub>3</sub> and  $\gamma$ -Al<sub>2</sub>O<sub>3</sub> were present, these  $d$  spacings and line intensities were compared to those listed in the card file for these materials (Guinier 1968).

## CHAPTER 4

### RESULT AND DISCUSSION

#### 4.1 Catalyst Synthesis

##### 4.1.1 Impregnation

The most common procedure for dispersing the catalytic species into the carrier is by impregnation an aqueous solution containing a salt (precursor) of the catalytic element or elements. Most preparations simply involve soaking the carrier in the solution and allowing capillary and electrostatic forces to distribute the salt within the porous network. The salt generating the cation or anions containing the catalytic element are chosen to be compatible with the surface charge of the carrier to obtain efficient adsorption or in some cases ion exchange. This procedure was used to distribute 5% Fe<sub>2</sub>O<sub>3</sub> in the  $\gamma$ -Al<sub>2</sub>O<sub>3</sub> pores.

##### 4.1.2 Incipient Wetness or Capillary Impregnation

In order to make 5%  $\alpha$ -Fe<sub>2</sub>O<sub>3</sub> / $\gamma$ -Al<sub>2</sub>O<sub>3</sub>, it is important to know the molecular weight of each material which is presented in each step. The physical properties of each iron compound is that could be used for catalyst synthesis as shown in Table 2. The reaction can be described as follows:

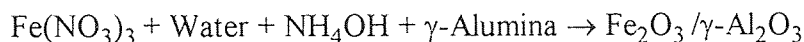

This experiment was designed for 5%  $\alpha$ -Fe<sub>2</sub>O<sub>3</sub> / $\gamma$ -Al<sub>2</sub>O<sub>3</sub>. That means 95%  $\gamma$ -Al<sub>2</sub>O<sub>3</sub> and 5% Fe<sub>2</sub>O<sub>3</sub> are needed at the conclusion of the catalyst synthesis. Two mols of Fe(NO<sub>3</sub>)<sub>3</sub> needed to produce 1 mol of Fe<sub>2</sub>O<sub>3</sub>.

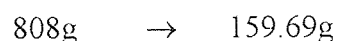
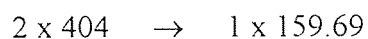
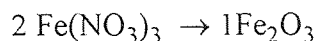

Therefore,

$$808 : 159.65 = 5 : X \quad , \quad X = 0.988$$

Where , X = g of  $\text{Fe}(\text{NO}_3)_3$  needed

When using 5 g of  $\text{Fe}(\text{NO}_3)_3$  , 0.988g of  $\text{Fe}_2\text{O}_3$  can be produced and requires 18.772 g of  $\gamma\text{-Al}_2\text{O}_3$  .

**Table 2** Physical Properties of the Iron Compound used for Catalyst Synthesis

	Mol Weight, g	Density, gm/cm <sup>3</sup>	Melting Point , °C
$\text{Fe}_2\text{O}_3$	159.69	5.24	1565
$\text{Fe}(\text{NO}_3)_3$	404.00	1.684	47.2
$\text{Fe}(\text{OH})_2$	89.86	3.4	d

The maximum water uptake by the carrier is referred to as the water pore volume. This is determined by slowly adding deionized water to a carrier until it is saturated as evident by the beading of the excess  $\text{H}_2\text{O}$ .  $\text{Fe}(\text{NO}_3)_3$  is then dissolve in an amount of water equal to the water pore volume. In this manner, the precise amount of  $\text{Fe}(\text{OH})_2$  is assured to be present in the carrier.

#### 4.1.3 Fixing the Active Component

Following impregnation, it is often desirable to fix the catalytic compounds so subsequent processing steps such as washing, drying and calcination will not cause significant movement or agglomeration of the well dispersed catalytic precursor materials.

##### 1. Precipitation

The pH of the solution is adjusted to precipitate the catalytic compounds in the pores of the carrier. A special case for producing the desired catalyst is when both carrier and catalytic compounds are co-precipitated simultaneously. Thus 5%  $\alpha\text{-Fe}_2\text{O}_3 / \gamma\text{-Al}_2\text{O}_3$  can

be prepared by adjusting the pH to 2 of a solution containing the iron salt and the  $\gamma\text{-Al}_2\text{O}_3$  component. This method is commonly used when large amounts of catalytic components i.e., greater than 15 %, are desired for a particular reaction.

#### 4.1.4 Drying

Excess water and other volatile components are removed during drying at about 110 °C for 24 hours with air flowing through the oven.

#### 4.1.5 Calcination

This is the last step in synthesizing a catalyst. Its purpose is to decompose and volatilize the various salt components not needed in the final catalyst. For 5%  $\alpha\text{-Fe}_2\text{O}_3$  / $\gamma\text{-Al}_2\text{O}_3$ , this is typically done in air at temperatures between 300-500 °C. Great care must be exercised to avoid rapid heating since  $\text{H}_2\text{O}$  trapped in the micro pores can build up sufficient pressure to crack particular carriers.

#### 4.1.6 X-ray Diffraction Crystallography

To test the crystalline nature of the catalyst, X-ray diffraction was used. A standard samples of  $\alpha\text{-Fe}_2\text{O}_3$  had narrow peaks at  $2\theta$  values of around 33°, 36°, 40.5°, 49.5°, 54°, 62°, 64° and 72° as shown in Figure 10. The  $\gamma\text{-Al}_2\text{O}_3$  had broad peaks at 32°, 37°, 39°, 45° and 67° as shown in Figure 11. The X-ray diffraction peaks of a  $\text{Fe}_2\text{O}_3$  catalyst on  $\gamma\text{-Al}_2\text{O}_3$ , which were prepared by using the incipient wetness method, contained all of the above peaks only after calcination (see Figure 12) not before (see Figure 13). That confirms that the catalyst which was prepared by incipient wetness must be calcinated to achieve the desired crystalline state, which is believed to be necessary for catalytic activity. Other X-ray diffraction spectra are included in the Appendix.

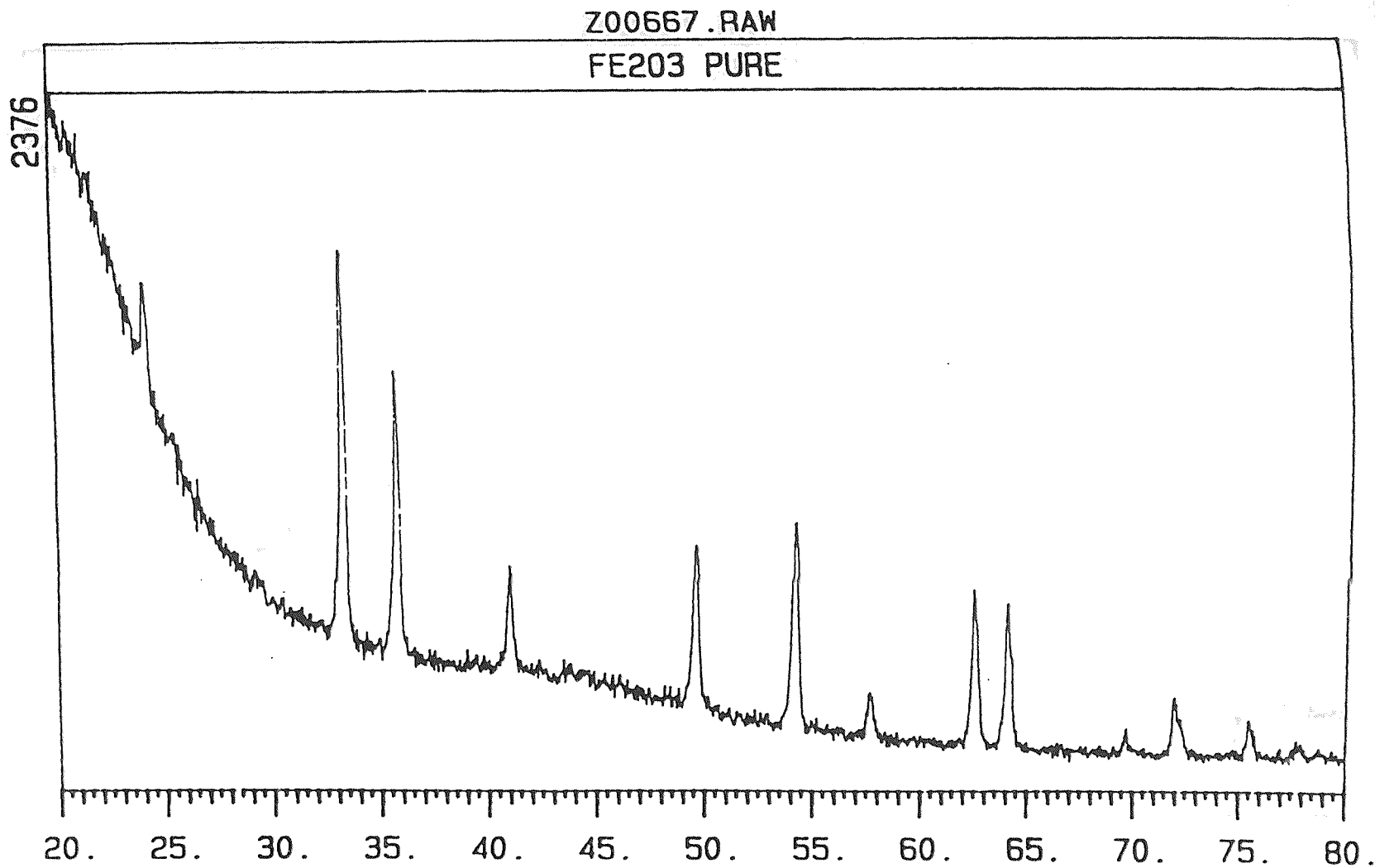

Figure 10 X-Ray Diffraction Spectrum of pure Fe<sub>2</sub>O<sub>3</sub>

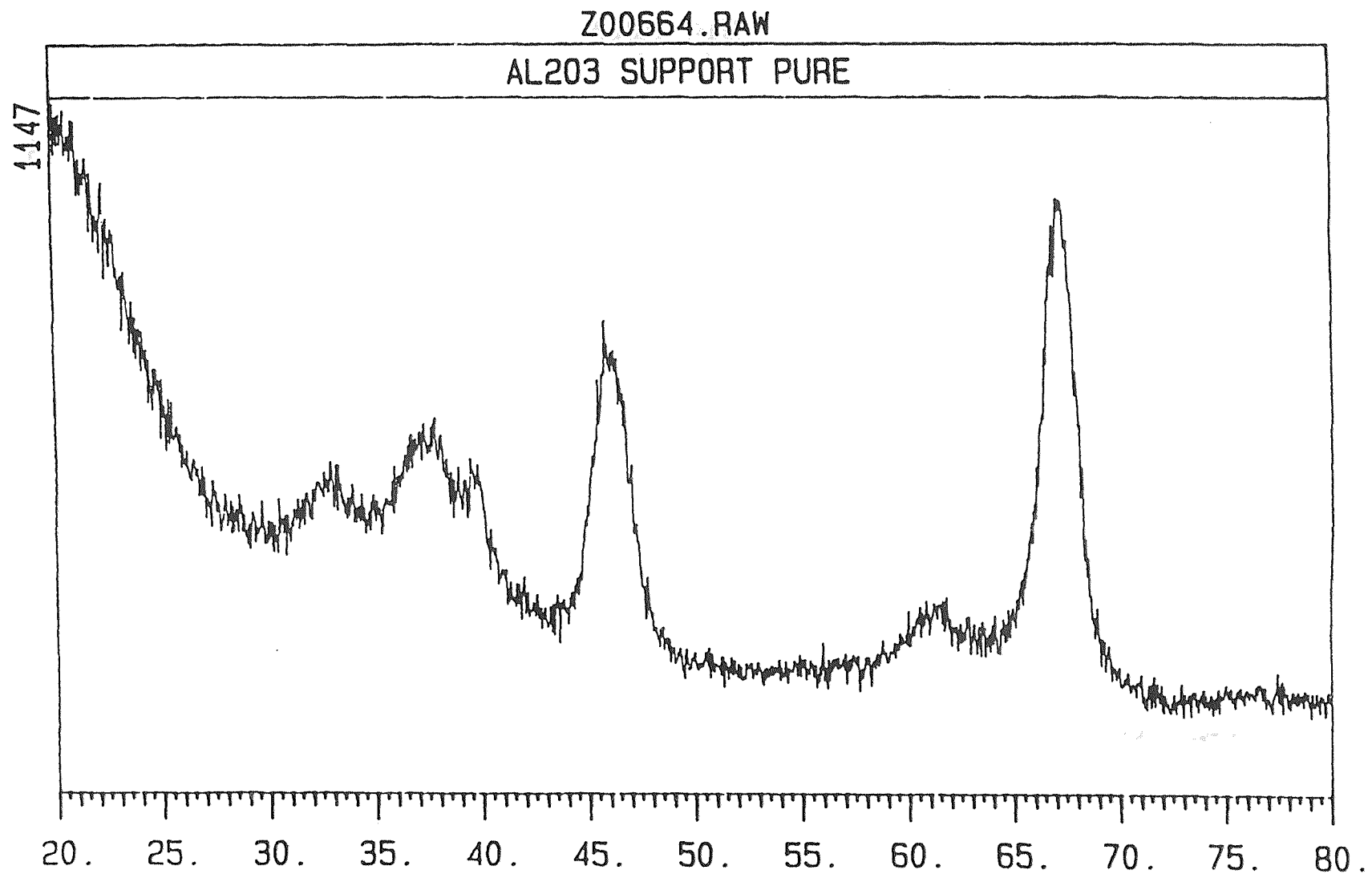

Figure 11 X-Ray Diffraction Spectrum of pure  $\gamma$ - $\text{Al}_2\text{O}_3$

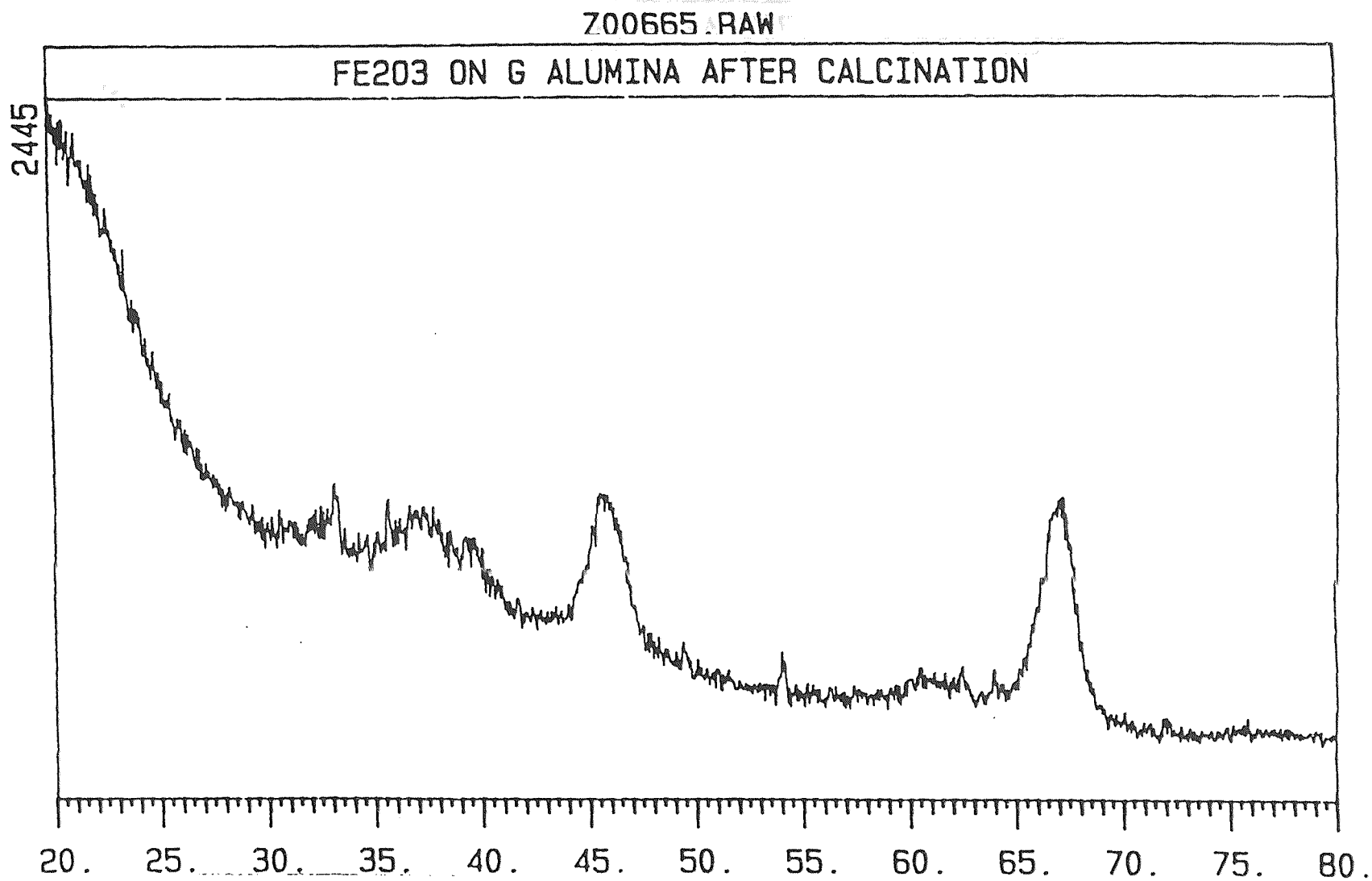

Figure 12 X-Ray Diffraction Spectrum of Catalyst after Calcination

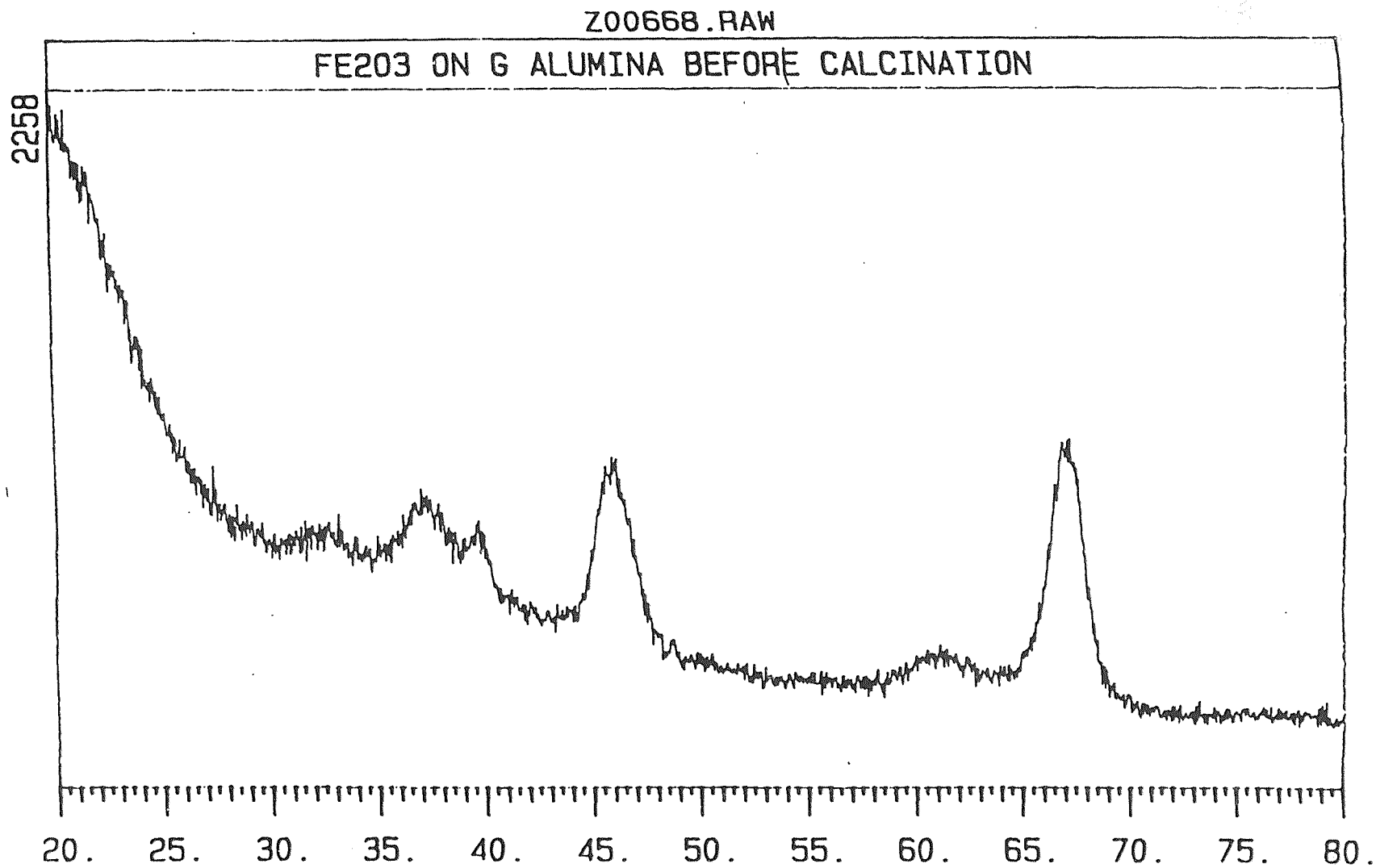

Figure 13 X-Ray Diffraction Spectrum of Catalyst before Calcination



## 4.2 Catalytic Oxidation of TCE over Powdered 5% $\alpha\text{-Fe}_2\text{O}_3/\gamma\text{-Al}_2\text{O}_3$

### 4.2.1 Catalyst and Space Velocity

The catalytic oxidation of TCE was conducted over 5%  $\alpha\text{-Fe}_2\text{O}_3/\gamma\text{-Al}_2\text{O}_3$ . For the indicated volume of catalyst and gas flow rate, the following space velocities were calculated:

$$V_{c1} = 10.5 \text{ cm}^3 \quad \text{Flow rate was } 259 \text{ cm}^3/\text{min}$$

$$V_{c2} = 5 \text{ cm}^3 \quad \text{Flow rate was } 616 \text{ cm}^3/\text{min}$$

$$V_{c3} = 5 \text{ cm}^3 \quad \text{Flow rate was } 1,104 \text{ cm}^3/\text{min}$$

$$\begin{aligned} \text{Space velocity (1)} &= \text{total flow rate} / \text{catalyst volume} \\ &= (259 \text{ cm}^3 / \text{min} \times 60 \text{ min} / \text{hr}) / 10.5 \text{ cm}^3 \\ &= 1,453 \text{ v/v/hr} \\ (2) &= 7,369 \text{ v/v/hr} \\ (3) &= 13,250 \text{ v/v/hr} \end{aligned}$$

### 4.2.2 Feed Concentration of TCE

In order to obtain 109 ppmv trichloroethylene, 1,000 ppmv trichloroethylene from the gas mixture cylinder was diluted almost ten times with dry air. The actual concentration of trichloroethylene was measured by gas chromatography at various intervals throughout each experiment.

### 4.2.3 The Effect of Temperature on TCE Oxidation

At a space velocities of 13,250, 7,369 and 1,453 v/v/hr and an initial concentration of 109 ppmv of trichloroethylene, the catalytic oxidation of TCE over 5%  $\alpha\text{-Fe}_2\text{O}_3/\gamma\text{-Al}_2\text{O}_3$  catalyst was conducted over the temperature range of 350 °C to 700 °C. The dependence of conversion of TCE on temperature is shown in Figure 14. The conversion is most sensitive to temperatures between 350 and 550 °C. The conversion is least sensitive to

temperature above 550 °C. This suggests that a chemical kinetics controlled zone exists in the temperatures 350-550 °C, and a mass transfer controlled zone occurs at temperature over 550 °C.

#### 4.2.4 The Effect of Space Velocities on TCE Oxidation

Experiments were conducted over the range of 1,453 to 13,250 v/v/hr. Increasing space velocity tends to decrease conversion for the same temperature. Or, alternatively, for the same conversion to be achieved, higher temperatures are need at higher space velocities. As shown in Figure 14, 99% conversion is achieved at 550 °C, while at 1,453 v/v/hr the temperature was only 500 °C.

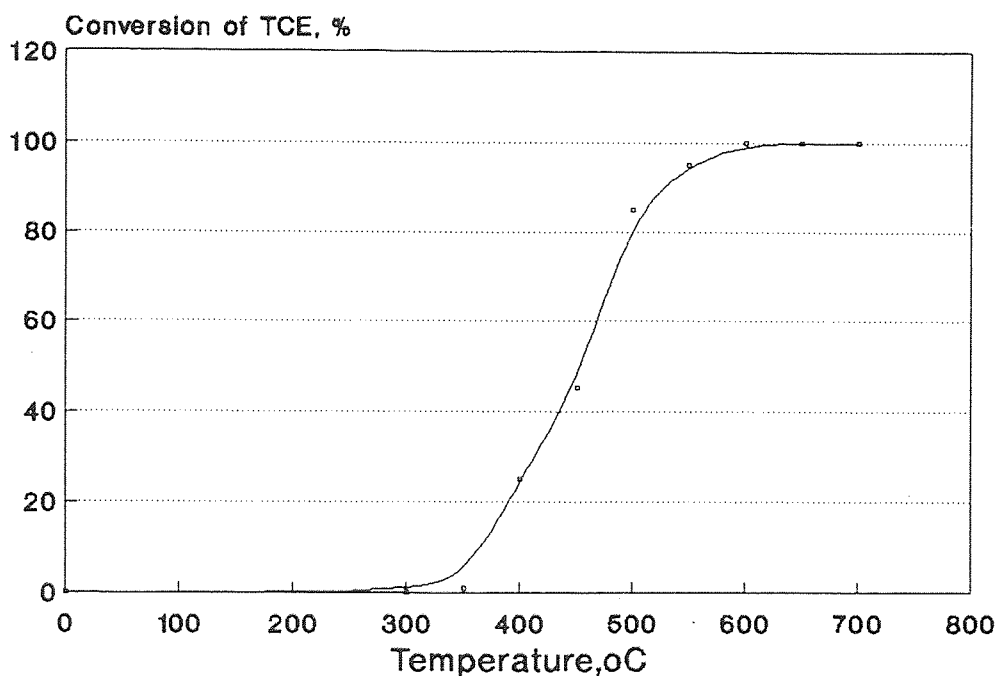

**Figure 14** Conversion of 109 ppm TCE as a Function of Temperature at 13,250 v/v/hr

#### 4.2.5 Product Distribution of TCE Oxidation over Powdered 5% $\alpha$ -Fe<sub>2</sub>O<sub>3</sub>/ $\gamma$ -Al<sub>2</sub>O<sub>3</sub>

The product distribution from the catalytic oxidation of TCE over 5%  $\alpha$ -Fe<sub>2</sub>O<sub>3</sub>/ $\gamma$ -Al<sub>2</sub>O<sub>3</sub> was conducted in the temperature range of 250 to 700 °C, and at the indicated space velocities of 13,250 and the initial concentrations of trichloroethylene 109 ppmv. The dependence of product distribution on temperature is plotted in Figure 15, The product distribution is summarized in Table 3. The main products are carbon dioxide, hydrogen chloride and chlorine. At low oxidation temperatures, the concentration of carbon monoxide increases with increasing temperature. The concentration of carbon monoxide reaches a maximum at a temperature of 450 °C and then decreases with increasing temperature.

**Table 3.** Material Balance of TCE Oxidation over 5%  $\alpha$ -Fe<sub>2</sub>O<sub>3</sub>/ $\gamma$ -Al<sub>2</sub>O<sub>3</sub>

Temp.	TCE	CO	CO <sub>2</sub>	HCl	Cl <sub>2</sub>
°C	ppm	ppm	ppm	ppm	ppm
300	109	.	.	.	.
350	108	.	.	.	.
400	83	38	22	.	.
450	62	65	30	91	29
500	25	89	86	102	77
550	4	63	128	110	91
600	.	21	159	119	94
650	.	.	191	115	99

The result for space velocities 1,453 v/v/hr and 7,396 v/v/hr are given in the Appendix.

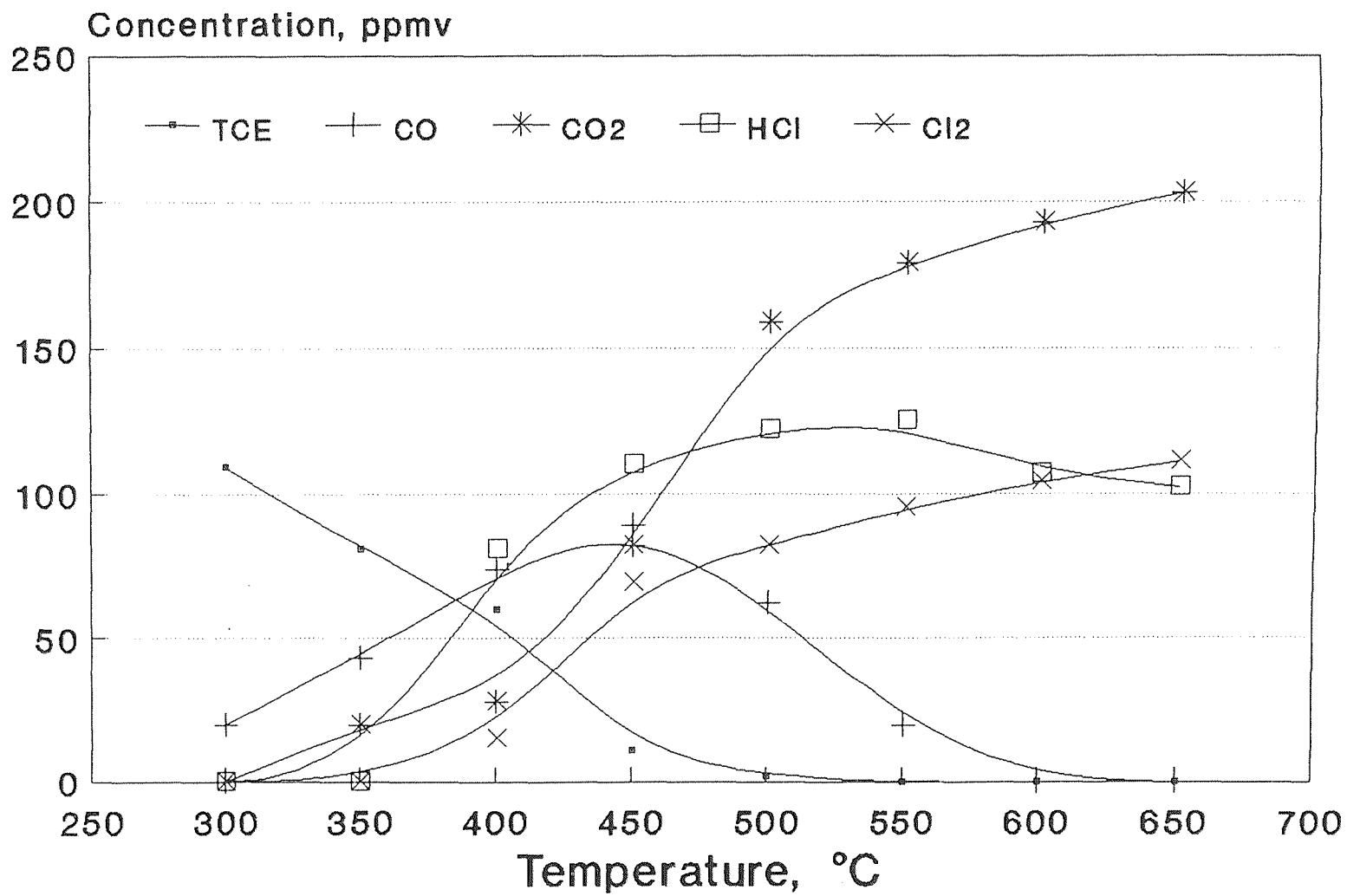

Figure 15 Catalytic Oxidation of TCE over 5%  $\alpha$ -Fe<sub>2</sub>O<sub>3</sub>/ $\gamma$ -Al<sub>2</sub>O<sub>3</sub> at 13,250 v/v/hr

### 4.3 Catalytic Oxidation of TCE over 5% $\alpha$ -Fe<sub>2</sub>O<sub>3</sub>/ $\gamma$ -Al<sub>2</sub>O<sub>3</sub>/monolith

#### 4.3.1 Catalyst and Space Velocity

The catalytic oxidation of TCE was conducted over 5%  $\alpha$ -Fe<sub>2</sub>O<sub>3</sub>/ $\gamma$ -Al<sub>2</sub>O<sub>3</sub> on monolith.

Volume of catalyst was calculated as follows:

Since the monolith contains 400 cells per square inches and 174 cells were blocked, 226 cells allowed to remain. The length of monolith was 0.9 cm, therefore, the actual volume of modified catalyst was (Wang, 1991):

$$\begin{aligned} V_c &= 0.9 \times (226/400) \times 2.54^2 \\ &= 3.28 \text{ cm}^3 \end{aligned}$$

Flow rate is 1,190 cm<sup>3</sup>/min

$$\begin{aligned} \text{Space velocity} &= \text{total flow rate} / \text{catalyst volume} \\ &= (1,190 \text{ cm}^3 / \text{min} \times 60 \text{ min} / \text{hr}) / 3.28 \text{ cm}^3 \\ &= 21,768 \text{ v/v/hr} \end{aligned}$$

However, different space velocities were obtained during the experiments by using different flow rates and different volumes of catalyst. All the data obtained in the research is included in the Appendix.

#### 4.3.2 Feed Concentration of TCE

In order to obtain 109 ppmv trichloroethylene, 1000 ppmv trichloroethylene from gas mixture cylinder was diluted almost ten times with dry air. The actual concentration of trichloroethylene that was feed to the catalytic reactor was measured by gas chromatography at various intervals throughout each experiment.

#### 4.3.3 The Effect of Temperature on TCE Oxidation

At a space velocity of 21,768 v/v/hr and an initial concentration of 109 ppmv of trichloroethylene, the catalytic oxidation of TCE over 5%  $\alpha$ -Fe<sub>2</sub>O<sub>3</sub>/ $\gamma$ -Al<sub>2</sub>O<sub>3</sub> catalyst was conducted in the temperature range of 350 °C to 700 °C. The dependence of conversion

of TCE on temperature is shown in Figure 16. The conversion is most sensitive to temperatures between 350 and 450 °C. The conversion of least sensitive to temperature above 550 °C. This suggests that a chemical kinetics controlled zone exists in the temperatures 350-450 °C, and a mass transfer controlled zone occurs at temperature over 550 °C.

#### 4.3.4 The Effect of Space Velocities on TCE Oxidation

Experiments were conducted over the range of 1,490 to 21,768 v/v/hr. In order to achieve the some conversion at higher space velocities, one must increase reaction temperature. As shown Figure 16, 99% conversion is achieved at 550 °C. Another important result is that two byproducts,  $\text{CCl}_4$  and  $\text{CHCl}_3$  were detected when the experiment was conducted at 21,768 v/v/hr space velocity. Other trace products were also observed but were not identify. It appears that these trace products may be present at concentration of less than 0.001 ppmv.

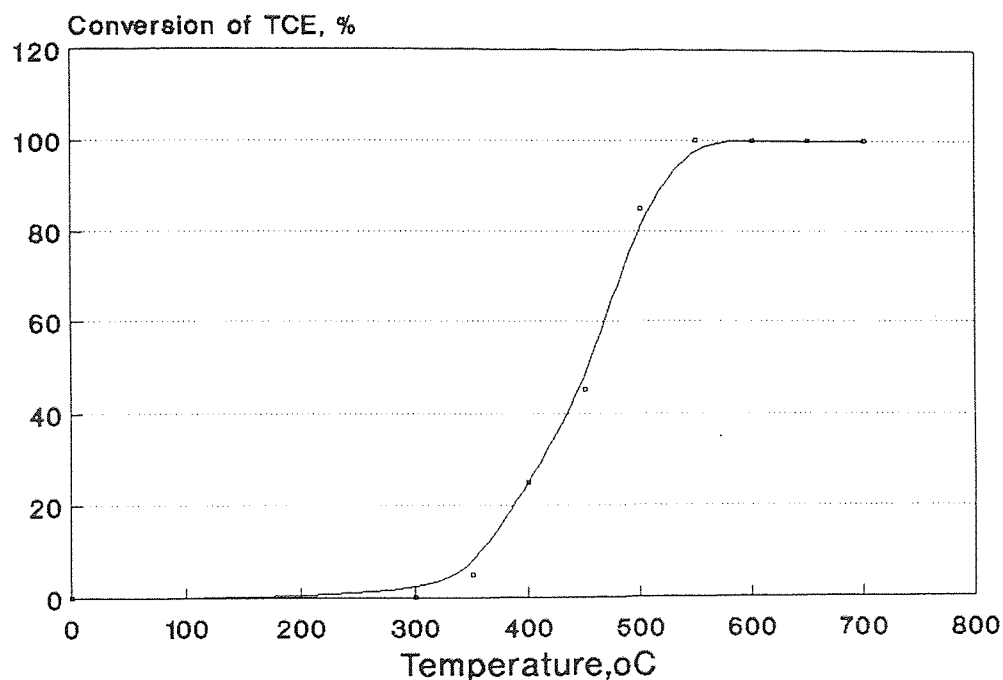

**Figure 16** Conversion of 109 ppm TCE as a Function of Temperature at 21,768 v/v/hr

### 4.3.5 Kinetic Studies of TCE Oxidation

In this experiments, the initial concentration of TCE was approximately 109 ppm, different space velocities were used for each case, and air was employed as the oxidant. For kinetic studies, the measured rates of oxidation of TCE in air are correlated first using the empirical power law as the form:

$$-r_{C_2HCl_3} = k' C_{C_2HCl_3}^a C_{O_2}^b$$

Where  $C_{C_2HCl_3}$  and  $C_{O_2}$  are the concentration of TCE and oxygen, respectively. Since the experiments were conducted in large excess of oxygen, one can assume the concentration of oxygen is constant and a pseudo first order rate constant can be measured that incorporated the concentration of oxygen. One can assume that the oxidation of TCE is first order with respect to TCE. This course must be verified experimentally.

In order to keep the reaction in the chemical kinetics controlled region, all data were collected at conversions of less than 30%. The linearity of the plots of logarithm of the  $(C_0/C)$  versus residence time shown in Figure 17 confirm that the oxidation of trichloroethylene over 5%  $\alpha$ -Fe<sub>2</sub>O<sub>3</sub> / $\gamma$ -Al<sub>2</sub>O<sub>3</sub> can be represented as first order reaction that follows the Arrhenius equation.

$$k = A \exp (-E_a/RT)$$

where: A is the preexponential factor, sec<sup>-1</sup>

E<sub>a</sub> is activation energy, kcal/mole,

R is gas constant, kcal/mole \* K

T is absolute temperature, K

then,  $\ln k = \ln A + (-E_a/R) * (1/T)$

Figure 18 is a plot of the logarithm of the rate constant versus 1/T. The E<sub>a</sub> and A were obtained from the slope and intercept. The activation energy, E<sub>a</sub>, is calculated as 23.2±1 kcal/mole and the preexponential factor, A, is 14.8±5 \* 10<sup>8</sup> sec<sup>-1</sup>. So, the rate equation can be written:

$$-r_{C_2HCl_3} = 14.8 * 10^8 (23.2 \pm 1/RT) * C_{C_2HCl_3}$$

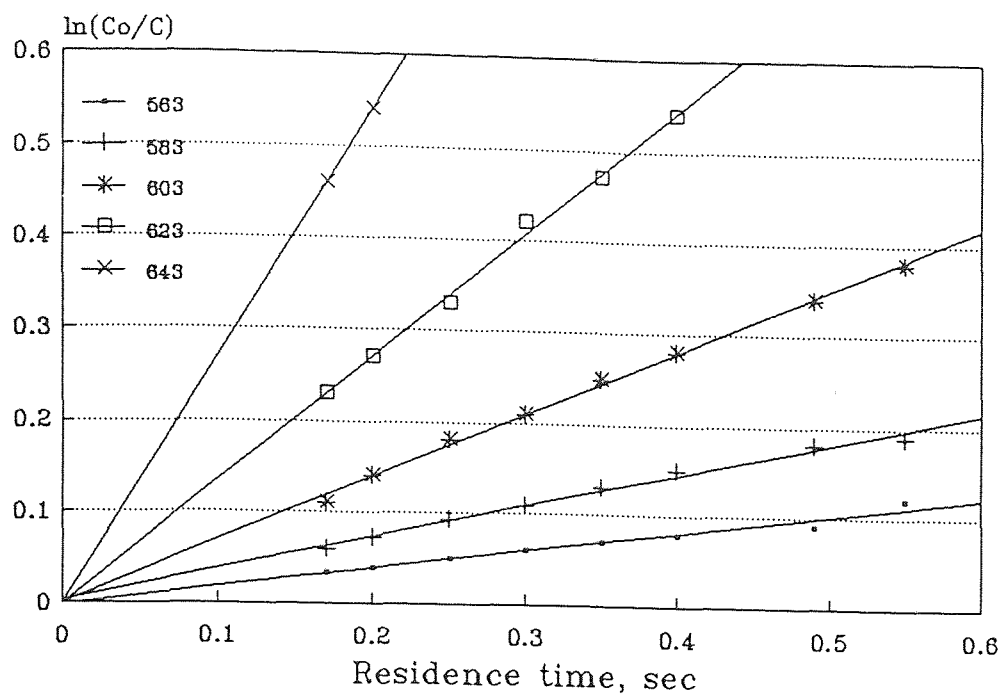

Figure 17 Plot used to obtain first order rate constants, i.e., slopes of the straight lines

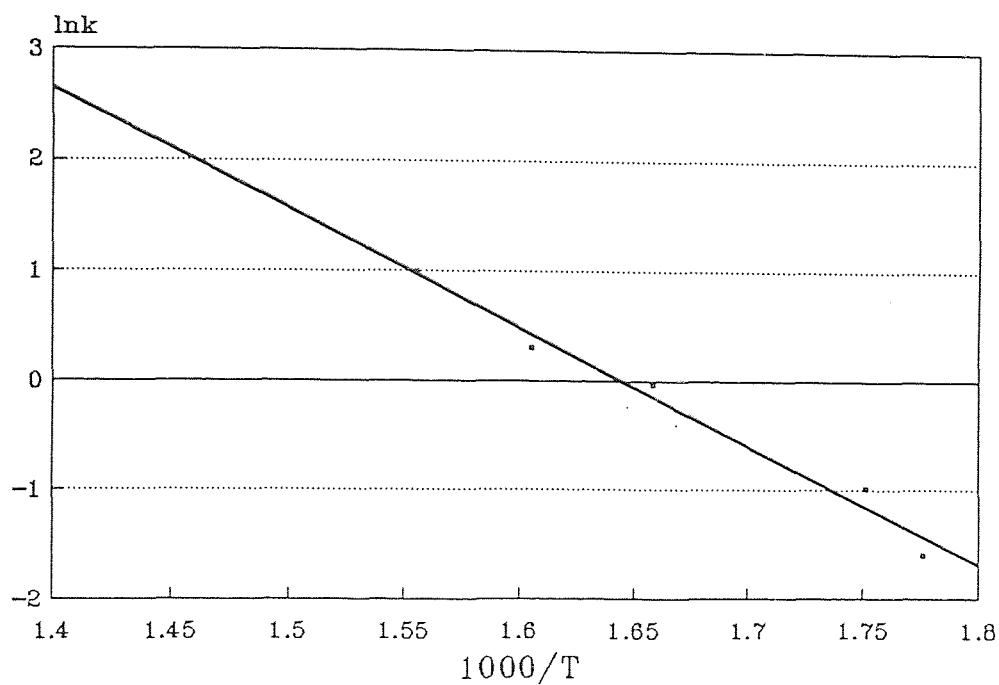

Figure 18 Arrhenius plot of first order rate constant for TCE oxidation 5%  $\alpha$ - $\text{Fe}_2\text{O}_3/\gamma$ - $\text{Al}_2\text{O}_3$ /monolith



#### 4.3.6 Product Distribution and Material Balance of TCE Oxidation over 5% $\alpha$ -Fe<sub>2</sub>O<sub>3</sub> / $\gamma$ -Al<sub>2</sub>O<sub>3</sub>/monolith

The product distribution from the catalytic oxidation of TCE over 5%  $\alpha$ -Fe<sub>2</sub>O<sub>3</sub> / $\gamma$ -Al<sub>2</sub>O<sub>3</sub> was conducted in the temperature range of 250 to 700 °C, and at the indicated space velocity of 21,768 v/v/hr and the initial concentrations of trichloroethylene 109 ppmv. The dependence of product distribution on temperature is plotted in Figure 19, The product distribution, material balances for carbon and chlorine are summarized in Table 4. The main products are carbon dioxide, hydrogen chloride and chlorine. Trace amounts of CCl<sub>4</sub> and CHCl<sub>3</sub> are produced. At low oxidation temperature, the concentration of carbon monoxide increases with increasing temperature. At a temperature of 500 °C, the concentration of carbon monoxide reaches a maximum and then decreases with increasing temperature.

**Table 4** Material Balance of TCE Oxidation over 5%  $\alpha$ -Fe<sub>2</sub>O<sub>3</sub> / $\gamma$ -Al<sub>2</sub>O<sub>3</sub>/monolith at 21,718 v/v/hr

Temp.	TCE	CCl <sub>4</sub>	CHCl <sub>3</sub>	CO	CO <sub>2</sub>	HCl	Cl <sub>2</sub>	Carbon	Chlorine
°C	ppm	ppm	ppm	ppm	ppm	ppm	ppm	Balance	Balance
300	109	.	.	.	.	.	.	100	100
350	100	.	.	.	.	.	.	98 ±5	98 ± 5
400	78	.	.	40	20	61	.	98 ±5	90±5
450	61	.	0.2	65	28	85	28.2	98.5±5	99.3±5
500	20	.	0.5	110	65	111	75.1	98.8±5	98.6±5
550	.	5	2	98	90	113	89.2	90.0±10	97.0±5
600	.	.	2.5	82	124	120	95.4	95.6±5	97.3±5
650	.	.	1.2	75	139	121	99.2	98.7±5	98.7±5
700	.	.	.	.	212	118	102	97.0±5	98.4±5

The result at 1,490 v/v/hr is included in the Appendix.

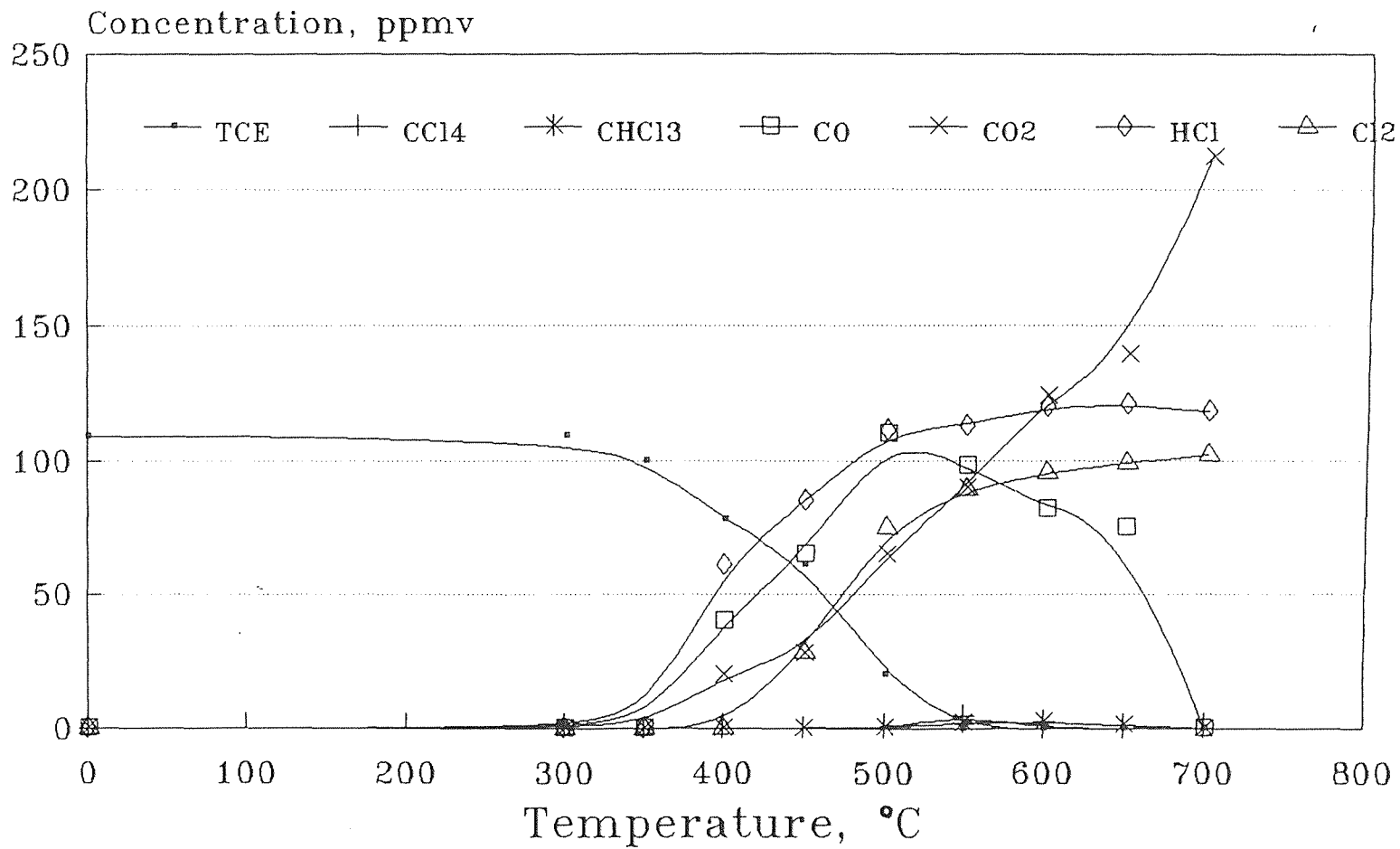

Figure 19 Catalytic Oxidation of TCE over 5%  $\alpha$ -Fe<sub>2</sub>O<sub>3</sub>/ $\gamma$ -Al<sub>2</sub>O<sub>3</sub>/monolith at 21,768 v/v/hr

## CHAPTER 5

### CONCLUSIONS

As a consequence of the research, the following conclusion were reached:

- The light-off temperature for oxidation of 109 ppm TCE over powdered 5%  $\alpha$ -Fe<sub>2</sub>O<sub>3</sub> / $\gamma$ -Al<sub>2</sub>O<sub>3</sub> at 13,250 v/v/hr is 350 °C, and 99 % conversion is achieved at 550 °C.
- The main products from the oxidation of trichloroethylene are carbon monoxide, carbon dioxide, hydrogen chloride, chlorine gas.
- Excellent carbon and chlorine balances are achieved for the oxidation of TCE over powdered 5%  $\alpha$ -Fe<sub>2</sub>O<sub>3</sub>/ $\gamma$ -Al<sub>2</sub>O<sub>3</sub> at a space velocity of 13,250 v/v/hr.
- The light-off temperature for oxidation of 109 ppm TCE over 5%  $\alpha$ -Fe<sub>2</sub>O<sub>3</sub>/ $\gamma$ -Al<sub>2</sub>O<sub>3</sub>/monolith/400 cpsi at 21,768 v/v/hr is 350 °C, and 99 % conversion is achieved at 500 °C.
- The main products from the oxidation of trichloroethylene over the catalyst based on a monolith are carbon monoxide, carbon dioxide, hydrogen chloride, chlorine gas. Trace amount of CCl<sub>4</sub> and CHCl<sub>3</sub> are found at higher space velocities.
- Excellent carbon and chlorine balances are achieved for oxidation of TCE over 5%  $\alpha$ -Fe<sub>2</sub>O<sub>3</sub>/ $\gamma$ -Al<sub>2</sub>O<sub>3</sub>/monolith at the space velocity of 21,768 v/v/hr even the temperature range of 350 to 550 °C.
- The oxidation reaction of TCE obeys pseudo first order reaction kinetics with respect to TCE.
- The activation energy, E<sub>a</sub>, for the oxidation of TCE over 5%  $\alpha$ -Fe<sub>2</sub>O<sub>3</sub> / $\gamma$ -Al<sub>2</sub>O<sub>3</sub> /monolith is  $23.2 \pm 1$  kcal/mole, and the preexponential factor, A, is  $14.8 \pm 5 * 10^8 \text{sec}^{-1}$ .
- A comparison with Xu's (1994) shows different result. First, she used powder Fe<sub>2</sub>O<sub>3</sub> without monolith or  $\gamma$ -Al<sub>2</sub>O<sub>3</sub>. The monolith helps provide better access to catalyst. Consequently, this catalyst tested as part of this research is more active than Xu's.

- Xu's research showed that the light-off temperature for oxidation of 100 ppmv TCE over powdered  $\text{Fe}_2\text{O}_3$  at 12,000 v/v/hr is 300 °C and 99 % conversion is achieved at 637 °C.
- A comparison of this research to Xu's research shows that the powdered  $\text{Fe}_2\text{O}_3$  needed almost 150 °C higher temperature to achieve 99% conversion.
- A comparison of the kinetic results showed that the improved activity results in lower activation energy and higher preexponential factor as summarized in Table 5.

**Table 5** Comparison between Xu's and this Research

	Xu's Research	This research	This research
Catalyst	$\text{Fe}_2\text{O}_3$ powder	5% $\alpha\text{-Fe}_2\text{O}_3/\gamma\text{-Al}_2\text{O}_3$	5% $\alpha\text{-Fe}_2\text{O}_3/\gamma\text{-Al}_2\text{O}_3$ /monolith
Light-off Temp. for Catalytic Oxidation	397 °C	350 °C	350 °C
99% Conversion	637 °C	550 °C	500 °C
Space Velocity	12,000 v/v/hr	13,250 v/v/hr	21,768 v/v/hr
Activation Energy	23.15± 1 kcal/mole	NA	23.2 ± 1 kcal/mole
Preexponential factor	14.75±5 * 10 <sup>8</sup> sec <sup>-1</sup>	NA	14.8±5 * 10 <sup>8</sup> sec <sup>-1</sup>

NA = Not Available

## APPENDIX A

### X-ray Diffraction Crystallography

Figure A 1 X-ray Diffraction Crystallography of Catalyst without Cordierite monolith

- \* Pure  $\gamma$ -Al<sub>2</sub>O<sub>3</sub> Support
- \* Pure  $\alpha$ -Fe<sub>2</sub>O<sub>3</sub>
- \* 5%  $\alpha$ -Fe<sub>2</sub>O<sub>3</sub>/ $\gamma$ -Al<sub>2</sub>O<sub>3</sub> before calcination
- \* 5%  $\alpha$ -Fe<sub>2</sub>O<sub>3</sub>/ $\gamma$ -Al<sub>2</sub>O<sub>3</sub> after Calcination

Figure A 2 X-ray Diffraction Crystallography of Catalyst with Cordierite monolith

- \* Pure  $\gamma$ -Al<sub>2</sub>O<sub>3</sub> Support
- \* Pure  $\alpha$ -Fe<sub>2</sub>O<sub>3</sub>
- \* 5%  $\alpha$ -Fe<sub>2</sub>O<sub>3</sub>/ $\gamma$ -Al<sub>2</sub>O<sub>3</sub> before calcination
- \* 5%  $\alpha$ -Fe<sub>2</sub>O<sub>3</sub>/ $\gamma$ -Al<sub>2</sub>O<sub>3</sub> after Calcination

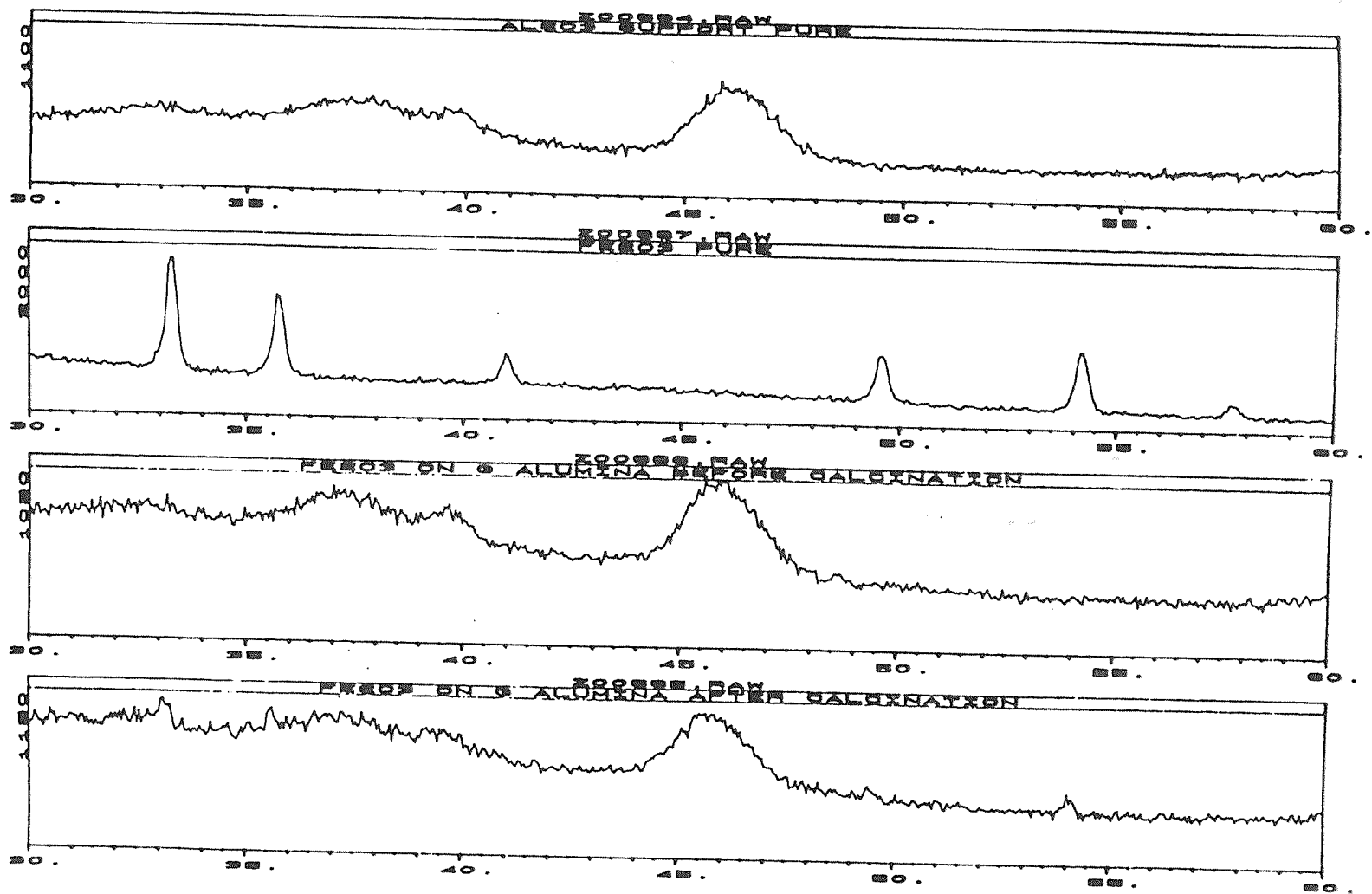

Figure A 20 X-Ray Diffraction Crystallography of Catalyst

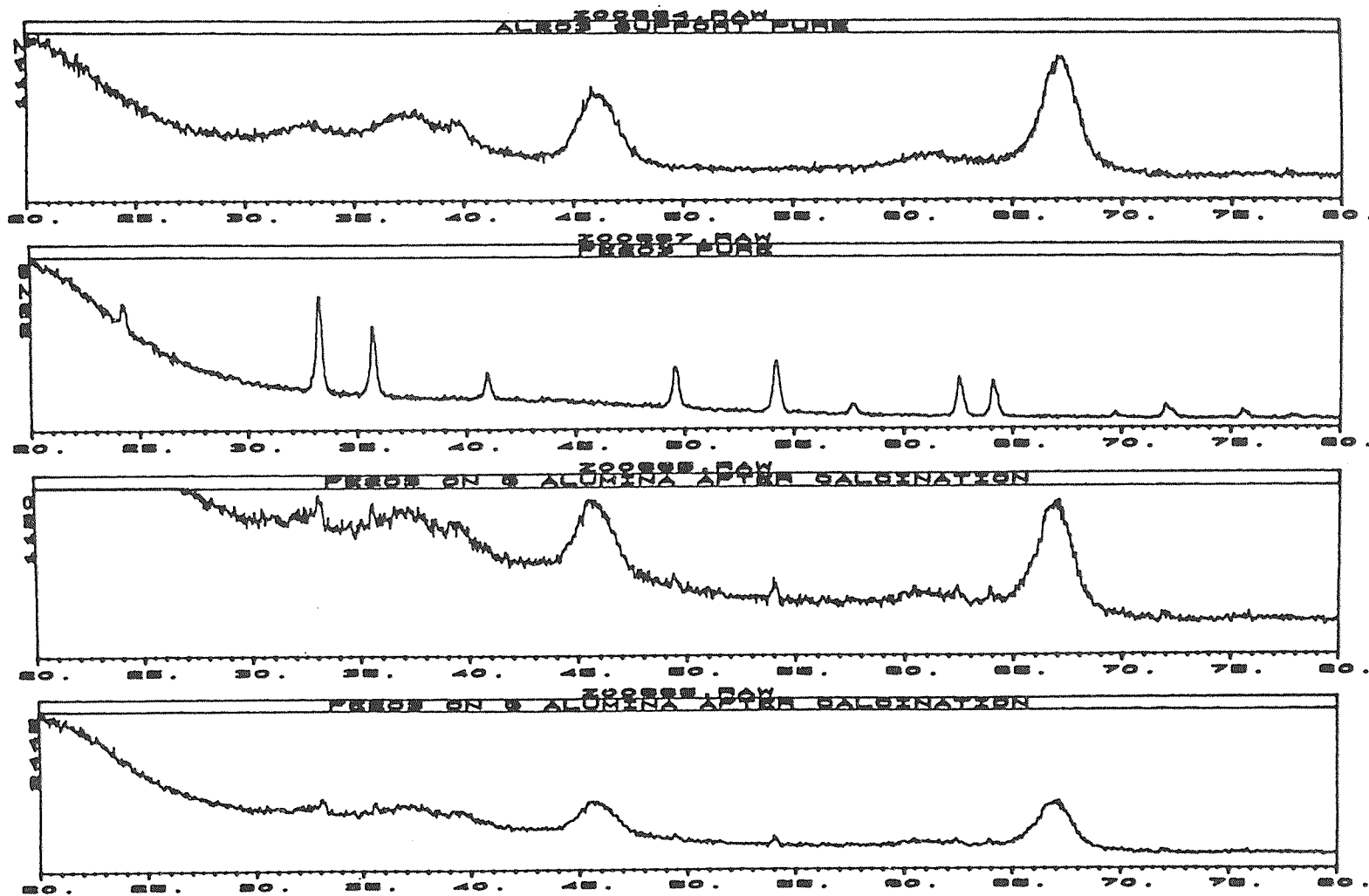

Figure A 21 X-Ray Diffraction Crystallography of Catalyst

## APPENDIX B

### Catalytic Oxidation of TCE over Powdered 5% $\alpha$ -Fe<sub>2</sub>O<sub>3</sub>/ $\gamma$ -Al<sub>2</sub>O<sub>3</sub>



**Table A 1** Product distribute of Catalytic Oxidation of TCE at 7,396 v/v/hr

Temp	TCE	CO	CO <sub>2</sub>	HCl	Cl <sub>2</sub>
°C	ppmv	ppmv	ppmv	ppmv	ppmv
300	109				
350	89	41	24		
400	63	71	29	85	27
450	32	93	77	105	78
500	2	70	131	117	85
550		62	154	120	94
600		12	181	118	100
650			204	118	111

**Table A 2** Product distribute of Catalytic Oxidation of TCE at 1,453 v/v/hr

Temp	TCE	CO	CO <sub>2</sub>	HCl	Cl <sub>2</sub>
°C	ppmv	ppmv	ppmv	ppmv	ppmv
300	109	20			
350	81	43	20		
400	60	74	28	81	15
450	11	89	82	110	69
500	0	62	159	122	82
550		20	179	125	95
600			193	107	104
650			203	102	111

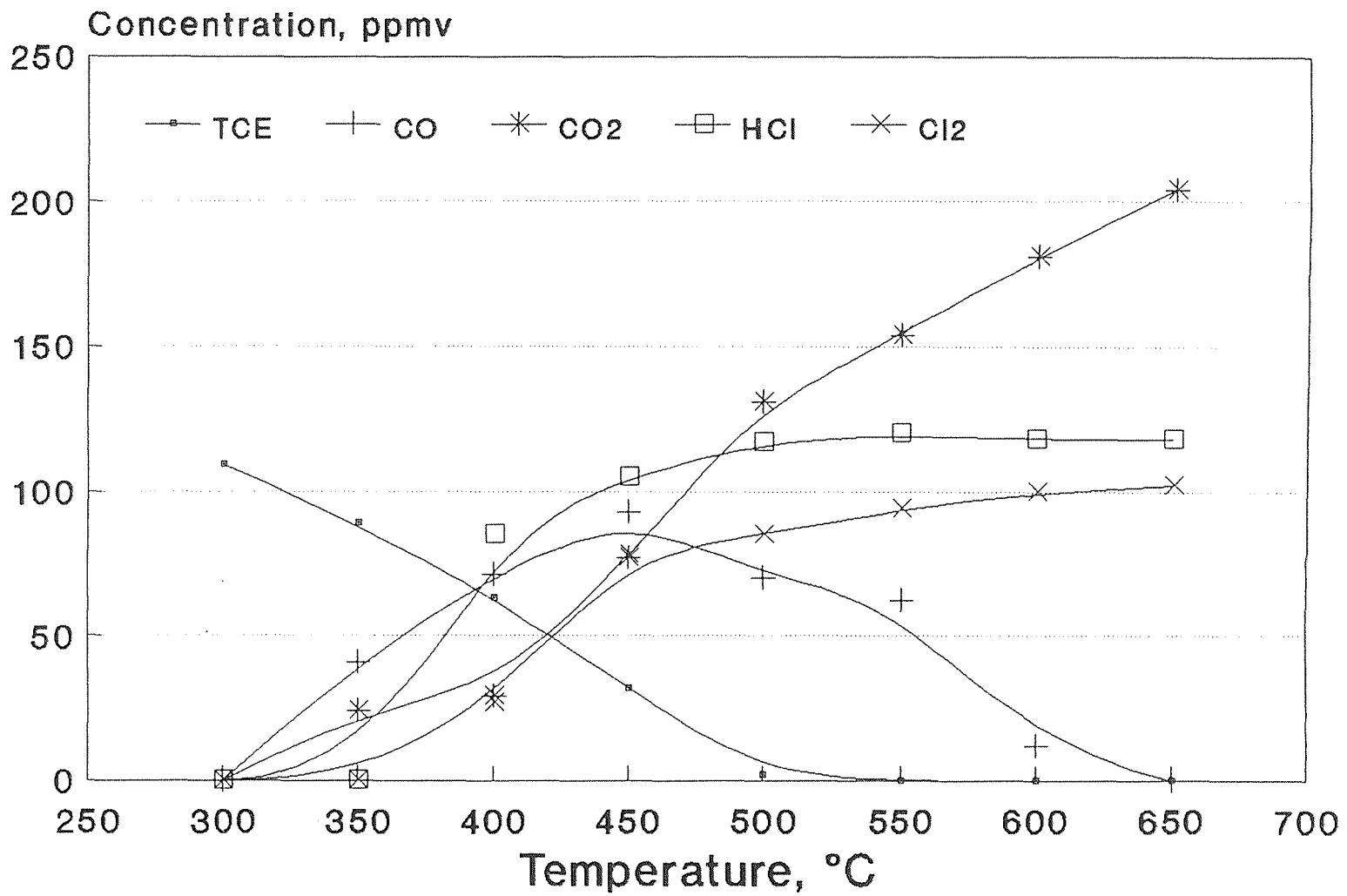

Figure A 3 Catalytic Oxidation of TCE over 5%  $\alpha$ -Fe<sub>2</sub>O<sub>3</sub>/ $\gamma$ -Al<sub>2</sub>O<sub>3</sub> at 7,396 v/v/hr

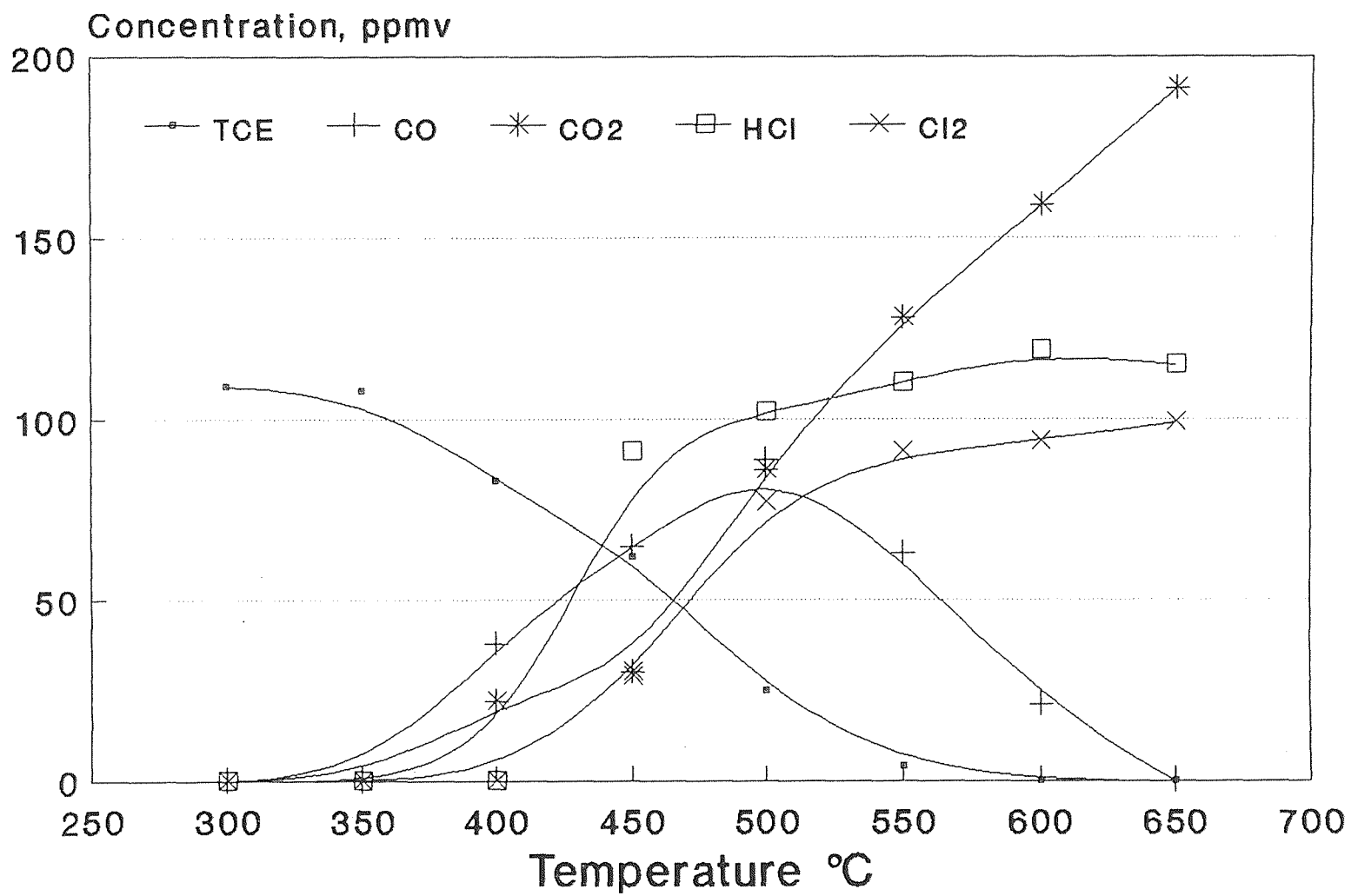

Figure A 4 Catalytic Oxidation of TCE over 5%  $\alpha$ -Fe<sub>2</sub>O<sub>3</sub>/ $\gamma$ -Al<sub>2</sub>O<sub>3</sub> at 1,453 v/v/hr

## APPENDIX C

### Catalytic Oxidation of TCE over 5% $\alpha$ -Fe<sub>2</sub>O<sub>3</sub>/ $\gamma$ -Al<sub>2</sub>O<sub>3</sub>/monolith

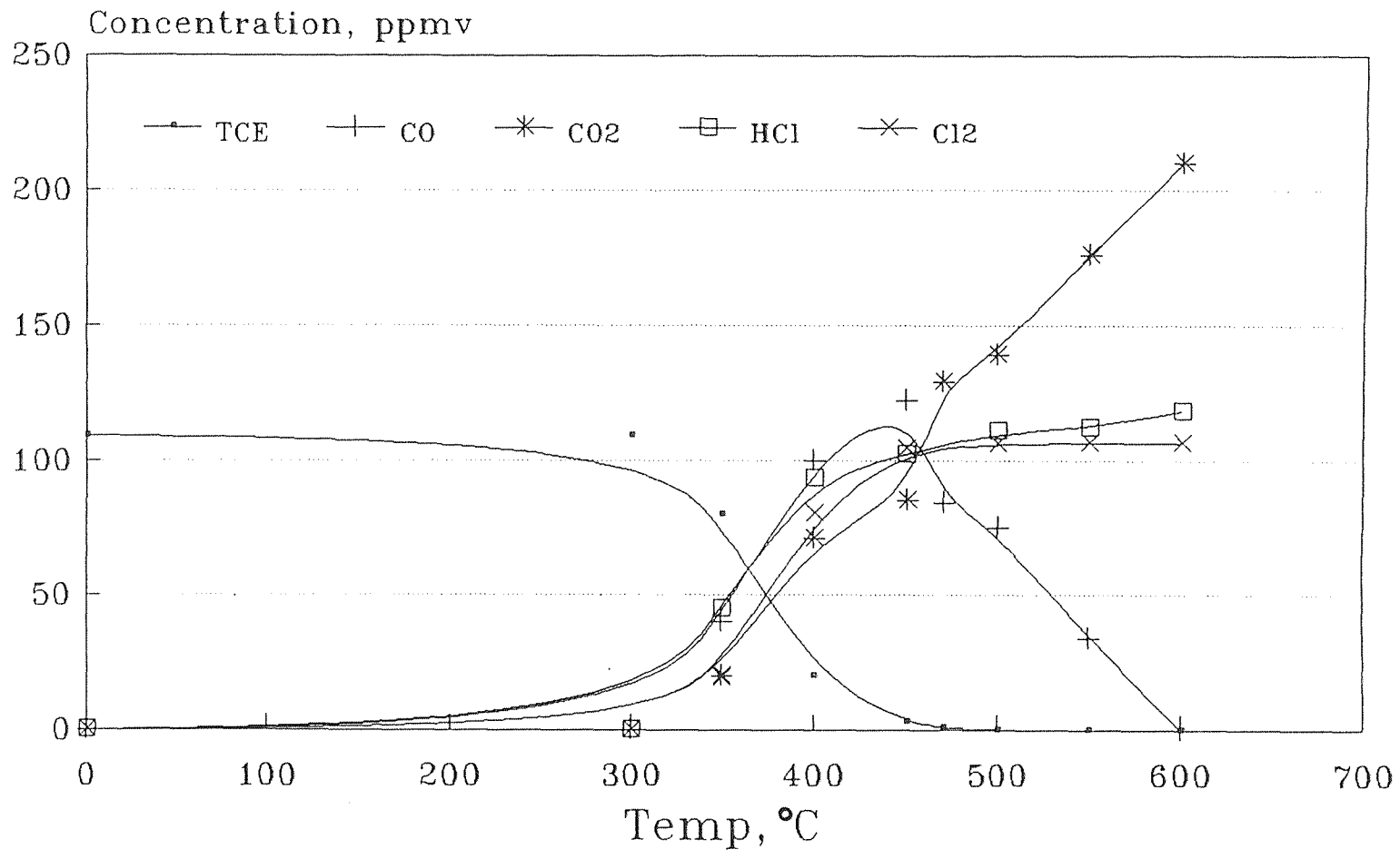

Figure A 5 Catalytic Oxidation of TCE over 5%  $\alpha$ -Fe<sub>2</sub>O<sub>3</sub>/ $\gamma$ -Al<sub>2</sub>O<sub>3</sub> /monolith at 1,490 v/v/hr

## REFERENCES

- Augustine, R.L., P.N. Rylader, and H. Greenfield, 1988, " *Catalysis of Organic Reaction*" Marcel Decker, New York.
- Boltz, D.F., and J. A. Howell, 1992, " Colormetric Determination of Nonmetals " *Chemical Analysis*, 8: 89.
- Bonacci, J. C., R.J. Farrauto, and R. M. Heck, 1988, " Catalytic incineration of Hazardous Waste " *Environmental Science*. I: Thermal Treatment, Gulf Publication.
- Bond, G.C., 1973, " Catalytic Destruction of Chlorinated hydrocarbons " *U.S. Patent*, No. 1485735.
- Cullity, B.D, 1980, " Elements of X-Ray Diffraction " *Department of Metallurgical Engineering and Materials Science*. University of Notre Dame Press, Indiana
- Du, J., 1990, " The Treatment of Trace Concentration of Chlorinated Hydrocarbon by Catalytic Oxidation " Masters Thesis , New Jersey Institute of Technology.
- Farrauto, R. J., R. M. Heck, and B.K. Spononello, 1992, "Environmental Catalysts." *C & EN*, September: 35-40.
- Griffiths, P.R., J. A. Dehaseth, and L. V. Azarraga, 1983, " Capillary GC/FT-IR. " *Analytical Chemistry*. 55: 1361 A.
- Guinier. A. 1968, "*X-ray Diffraction*" pgs. 27-51 University of Paris, Paris France.
- Heck, R. M., R. J. Farrauto, 1994, " *Catalytic Air Pollution Control* " Van Nostrand Reinhold, New York.
- Huang, S. L., and L. D. Pfefferle, 1989, " Methyl Chloride and Methylene Chloride Incineration in a Catalytically Stabilized Thermal Combuster" *Environmental Science & Technology* 23: No. 9.
- Jennings, M.S., and M. S. Palazzolo, 1985, " Catalytic Incineration for Control of Volatile Organic Compound Emission " *Pollution Tech. Rev.* No. 121.
- Johnston, E. J., and M. Jerome, 1976, " Catalytic Oxidation of C2-C4 Halogenated Hydrocarbons " *USA Patent*, No. 4039623.

## REFERENCES

( Continued )

- Kovenklioglu S., Z. Cao, D. Shah, R. J. Farrauto, E.N. Balko, 1992, " Direct Catalytic Hydrochlorination of Toxic Organics in Water " *AIChE J.* July 1992, Vol 38, No 7 Pgs. 1003-1012.
- Lavanish J. M., E.J., Sare and M. Jerome, 1976, " Catalytic Oxidation of C<sub>2</sub>-C<sub>4</sub> Halogenated Hydrocarbons " *USA Patent* No. 4039623.
- Lester, G. R., 1990, " Catalytic Destruction of Organhalogen Compound" *International Patent BOIJ 23/64*, No. A62D3100, International Publication Number WO 90/13352.
- Mars, P. D.W. van Krevelen, 1954, " Oxidation Carried Out by Means of Vanadium Oxide Catalyst" *Chem Eng. Sci. Suppl. vol. 3, pp. 41-59.*
- Narayanan, S.; Greene, H. L., 1990, " Deactivation by H<sub>2</sub>S of Cr<sub>2</sub>O<sub>3</sub> Emission Control Catalyst for Chlorinated VOC Destruction " *presented at the 83rd Annual AWMA Meeting Pittsburgh, PA, June 24-29.*
- Pope, D., D. S. Walker, and R. L. Moss., 1978, " Evaluation of Platinum-Honeycomb Catalyst for the Destructive Oxidation of Low Concentrations of Odorous Compounds in Air " *Atm. Environ.* 12: 1921-1969.
- Ramanathan, K., J. J. Spivey, 1989, " Catalytic Oxidation of 1,1-Dichloroethane " *Combust. Sci. and Tech.* 1989, vol . 63, pp. 247-255.
- Reid, R. C., J. M. Prausnitz, and B. E. Poling, 1987, " *The Properties of Gases and Liquids* " McGraw-Hill, New York
- Sare E.J., J. M. Lavanish, M. Jerome, 1977, " Catalytic Oxidation of C<sub>2</sub>-C<sub>4</sub> Halogenated Hydrocarbons " *USA Patent* No. 4059677.
- Sachlter, W. M.H., N. H., de Boer, 1965, " Catalytic Oxidation of propylene to Acrolein " *Proc. 3<sup>rd</sup> Int. Cong. Catal.*; North holland: Amsterdam, 1965: pp 252-265.
- Senkan, S. M., Chang W. D., S.B. Karra, 1986, " A Detailed mechanism for the High Temperature Oxidation of C<sub>2</sub>HCl<sub>3</sub> " *Combustion Sci. & Tech.* , vol. 49, ppg. 107-121.

## REFERENCES

( Continued )

- Senkan, S. M., J. Weldon, 1986, " Catalytic Oxidation of  $\text{CH}_3\text{Cl}$  by  $\text{Cr}_2\text{O}_3$  " *Combustion Sci. & Tech.*, vol. 47, pp. 229-237.
- Simmons, Th. G.J., E. J. Verheyen, P. A. Batist, G.C.A. Schuit, 1968, " Oxidation on Metal Oxide Surface " *Adv. chem. Ser.*, vol. 76(II), pp. 261-275.
- Satterfield, C. N., 1990, " *Heterogeneous Catalysis in Practice* " McGraw-Hill, New York.
- Schaumburg, F. D., 1990, " Banning Trichloroethylene: Responsible Reaction or Overkill " *Environ. Sci. & Tech.* 24: No. 1.
- Shaw, H., Y. Wang, T. C. Yu, and A. E. Cerkanowicz, 1993, " Catalytic Oxidation of Trichloroethylene and Methylene Chloride." *Emerging Technologies in Hazardous Waste Management*, 17: 359-379.
- Skoog D. A., and J. Leary. 1992, " *Principles of Instrumental Analysis* " Sanders Colleague Publishing.
- Subbanna, P., H Green, F. Desai, 1988, "Catalytic Oxidation of Polychlorinated Monolithic Reactor System" *Environ. Sci. Technol. F. vol. 22*, pp.557-561.
- Tanguay, J.F., S. L. Suib, and R. W. Conghlin, 1989, " Photodegradation of Dichloromethane with Titanium Catalyst " *American Chemical Society Miami Beach Meeting also Published in J. Catalyst* 1989, 117 (2) 33547.
- Wang, Y., 1991, " Catalytic Oxidation of Trace Concentration of Chlorinated Hydrocarbons over 1.5% Platinum on Alumina/monolith. " *Master Thesis*, New Jersey Institute of Technology.
- Xu, Sanmei, 1994, " Catalytic Oxidation of Chlorinated Hydrocarbos Over  $\text{Fe}_2\text{O}_3$  " *Master Thesis*, New Jersey Institute of Technology.
- Yao. D. V., 1984, " *Hydrogenation in Solutions* " Danniell Davey & Co. New York.
- Young P.W and C.B. Clark, 1982, " Heterogeneous Catalyst " *Chem. Eng. Prog.*, 69 (5). 69.