

Fall 1-31-1996

Design for quality manufacturability analysis of total nonconformity damaged parts

Samir R. Gami
New Jersey Institute of Technology

Follow this and additional works at: <https://digitalcommons.njit.edu/theses>



Part of the [Manufacturing Commons](#)

Recommended Citation

Gami, Samir R., "Design for quality manufacturability analysis of total nonconformity damaged parts" (1996). *Theses*. 1092.

<https://digitalcommons.njit.edu/theses/1092>

This Thesis is brought to you for free and open access by the Electronic Theses and Dissertations at Digital Commons @ NJIT. It has been accepted for inclusion in Theses by an authorized administrator of Digital Commons @ NJIT. For more information, please contact digitalcommons@njit.edu.

Copyright Warning & Restrictions

The copyright law of the United States (Title 17, United States Code) governs the making of photocopies or other reproductions of copyrighted material.

Under certain conditions specified in the law, libraries and archives are authorized to furnish a photocopy or other reproduction. One of these specified conditions is that the photocopy or reproduction is not to be “used for any purpose other than private study, scholarship, or research.” If a user makes a request for, or later uses, a photocopy or reproduction for purposes in excess of “fair use” that user may be liable for copyright infringement,

This institution reserves the right to refuse to accept a copying order if, in its judgment, fulfillment of the order would involve violation of copyright law.

Please Note: The author retains the copyright while the New Jersey Institute of Technology reserves the right to distribute this thesis or dissertation

Printing note: If you do not wish to print this page, then select “Pages from: first page # to: last page #” on the print dialog screen

The Van Houten library has removed some of the personal information and all signatures from the approval page and biographical sketches of theses and dissertations in order to protect the identity of NJIT graduates and faculty.

ABSTRACT

DESIGN FOR QUALITY MANUFACTURABILITY ANALYSIS OF TOTAL NONCONFORMITY AND DAMAGED PARTS

by
Samir R. Gami

The competitive nature of modern manufacturing, demands that innovative approaches be applied in order to have a competitive edge. Shortening the product development cycle, the period from initial design to full production, is a priority for most manufacturers today. The DFQM methodology addresses the issue of quality manufacturability (QM) - the likelihood that defects will occur during manufacture of a product in a standard plant. As a consequence, DFQM helps to shorten the design cycle time. The DFQM architecture identifies a variety of design factors and variables that influence specific defects. This process of influencing defects can be described by error catalysts.

This thesis presents the design of the error catalyst associated with two classes of defects, which are total nonconformity and damaged parts. Error catalysts are described in the form of catalysis graphs. Each catalysis graph leads to an index between "0" and "1", based on the factor variables for the given design, implying the likelihood of occurrence of that specific defect. The overall QM Index of a design is derived from these values. The error catalysts associated with defect class total nonconformity helps to identify features in design that results into poor quality product when it is assembled. The error catalyst associated with defect class damaged parts, helps to introduce rigidity and optimize aesthetics in product.

The DFQM analysis is then applied on an example product to illustrate the practical feasibility of the methodology.

**DESIGN FOR QUALITY MANUFACTURABILITY ANALYSIS
OF TOTAL NONCONFORMITY AND DAMAGED PARTS**

by
Samir R. Gami

**A Thesis
Submitted to the Faculty of
New Jersey Institute of Technology
in Partial Fulfillment of the Requirements for the Degree of
Master of Science in Manufacturing Systems Engineering**

Department of Industrial and Manufacturing Engineering

January 1996

APPROVAL PAGE

DESIGN FOR QUALITY MANUFACTURABILITY ANALYSIS
OF TOTAL NONCONFORMITY AND DAMAGED PARTS

Samir R. Gami

Dr. Sanchoy K. Das, Thesis Advisor _____ Date
Associate Professor of Industrial and Manufacturing Engineering, NJIT

~~_____~~
~~Dr. Layek Abdel-Malek, Committee Member _____ Date~~
~~Professor of Industrial and Manufacturing Engineering, NJIT~~

Dr. Rajpal S. Sodhi, Committee Member _____ Date
Associate Professor of Mechanical Engineering, NJIT

BIOGRAPHICAL SKETCH

Author: Samir R. Gami

Degree: Master of Science in Manufacturing Systems Engineering

Date: January 1996

Undergraduate and Graduate Education:

- Master of Science in Manufacturing Systems Engineering,
New Jersey Institute of Technology, Newark, New Jersey, 1996
- Bachelor of Engineering in Production Engineering,
Saurashtra University, Rajkot, India, 1993

Major: Manufacturing Systems Engineering

*This thesis is dedicated to
my parents*

ACKNOWLEDGMENT

The author wishes to express his sincere gratitude to his advisor, Dr. Sanchoy K. Das, for his guidance, friendship, and moral support throughout this research.

Special thanks to Dr. Layek Abdel-Malek and Dr. Rajpal S. Sodhi for serving as members of the committee.

The author is grateful to the National Science Foundation for partial funding of the research.

The author appreciates the timely help and suggestions from colleagues including: Altaf Tamboo, Abhinav Dhar, Suriyanarayan Ramachandra and Prashanti.

Dr. Herman A. Estrin provided expert assistance on thesis format in his thesis writing workshop.

Last but not least, the author would like to thank Dr. Ronald Kane and Ms. Annette Damiano for their timely help in documentation of this thesis.

TABLE OF CONTENTS

Chapter	Page
1 INTRODUCTION.....	1
1.1 Product Development Cycle.....	1
1.2 Design for Manufacture.....	3
1.3 Design for Quality Manufacturability.....	4
1.4 Research Objective.....	6
1.5 Organization of the Thesis.....	6
2 LITERATURE SURVEY.....	7
2.1 Quality.....	7
2.2 Concurrent Engineering.....	8
2.3 Design for Manufacture Techniques.....	9
2.4 Design for Quality Manufacturability (DFQM).....	10
2.5 Summary.....	12
3 DFQM ANALYSIS OF TOTAL NONCONFORMITY.....	13
3.1 Introduction.....	13
3.2 Relationship Between Specific Defects, Error Catalysts and Factor Variables.....	14
3.3 DFQM Analysis of Total Nonconformity.....	15
3.3.1 Surface Nonconformity.....	15
3.3.2 Dimensional Nonconformity.....	22
3.3.3 Design Nonconformity.....	27

TABLE OF CONTENTS
(Continued)

Chapter	Page
4 DFQM ANALYSIS FOR DAMAGED PARTS.....	30
4.1 DFQM Analysis of Damaged Parts.....	30
4.1.1 Damaged Parts.....	30
4.1.2 Physical Damage.....	32
4.1.3 Aesthetic Damage.....	37
5 DFQM ANALYSIS OF RUBBER STAMP ASSEMBLY	44
5.1 Introduction.....	44
5.2 Rubber Stamp Assembly.....	44
5.3 Input Data for DFQM Analysis.....	49
5.4 DFQM Analysis.....	54
5.4.1 DFQM Analysis of Missing/Misplaced Parts.....	54
5.5 Output of DFQM Analysis.....	57
6 CONCLUSION.....	59
6.1 Conclusion.....	59
6.2 Future Research.....	60
APPENDIX A: DFQM INPUT FORMS.....	62
APPENDIX B: CATALYSIS GRAPH FOR DEFECT CLASS MISSING/ MISPLACED PARTS.....	66
REFERENCES.....	76

LIST OF TABLES

Table	Page
5.1 Input Data for DFQM Analysis.....	50
5.2 DFQM Analysis for Missing/Misplaced Parts.....	55
5.3 Quality Manufacturability Matrix.....	57

LIST OF FIGURES

Figure	Page
1.1 DFQM Project.....	5
1.2 Spectrum of Quality Defects.....	6
2.1 DFQM Architecture.....	11
3.1 Catalysis Graph for bending of the part during material handling or assembly.....	16
3.2 Catalysis Graph for improper surface finish of the part.....	17
3.3 Catalysis Graph for effects of the manufacturing environment on surface.....	18
3.4 Catalysis Graph for materials with embedded particles.....	19
3.5 Catalysis Graph for machining of complicated surfaces.....	23
3.6 Catalysis Graph for effect of process on different physical properties of materials....	24
3.7 Catalysis Graph for wear incase of mating surfaces.....	25
3.8 Catalysis Graph for physical mating relationship between components.....	28
4.1 Examples of design features that causes physical damage.....	31
4.2 Catalysis Graph for gravity feeding of parts.....	33
4.3 Catalysis Graph for excessive fixturing force.....	34
4.4 Catalysis Graph for use of power fastening devices.....	35
4.5 Catalysis Graph for excessive gripping force incase of robotic handling.....	36
4.6 Catalysis Graph for gravity feeding or vibratory bowl feeder.....	39
4.7 Catalysis Graph for improper fixturing during drilling or power fastening.....	40
4.8 Catalysis Graph for common conveyor lines.....	41
4.9 Catalysis Graph for grippers used during assembly.....	42
5.1 Assembly of rubber stamp.....	45
5.2 Exploded view of rubber stamp assembly.....	46

CHAPTER 1

INTRODUCTION

Rigorous international competition, expansion of consumer markets and rapid technological change have created a set of competitive imperatives (speed, efficiency, and quality) for the development of new products and processes. The Design for Quality Manufacturability (DFQM) is a methodology to address the manufacturing/assembly quality issues during design. The DFQM architecture identifies a variety of design factors and variables that influence the specific defects. The defects found in assembled products is classified in six basic classes. This thesis presents the analysis of two classes of defects, total nonconformity and damaged parts.

1.1 Product Development Cycle

Firms that get to the market faster and more efficiently with quality products that are well matched to the needs and expectations of target customers usually enjoy significant competitive advantage. Shortening the product development cycle, the period from initial design to full production, occur concurrently with improving quality management. This reduces the opportunity for the work to be damaged and shortening the time between defect occurrence and defect detection.

It is known that new product or process development involves a complex set of activities that cuts across most functions in business. Traditionally, in first two phases- concept development and product planning-information about market opportunities, competitive moves, technical possibilities, and production requirements are analyzed to develop the initial design. Once approved, the project moves into the detailed engineering

phase, where design and construction of working prototypes are done. Both product and processes are laid out in concept, a working model are formed and then subjected to tests that simulate product use. The conclusion of the detailed engineering phase of product development is marked by an engineering "release." At this time the firm typically moves development into pilot manufacturing phase, during which the individual components are built, assembled and tested on factory equipment. Typically, during this phase, a number of problems must still be resolved before a product of a desired quality can be built. During this phase design is iteratively changed by the design group and the manufacturing group. At conclusion of this phase, the firm produces products for commercial sale and, brings the volume of production up to its targeted level.

In order to minimize production problems and delay, management have started to address manufacturing and quality issues before the production stage. This has led to concept of building the product for ease of manufacture and assembly started to evolve Designer's role in incorporating manufacturing and assembly issues started gaining prominence. It is established that approximately 75% to 80% of the product cost is determined at the design stage. It is therefore important that all downstream issues be analyzed during design stage. As a result of this, people from different areas, product design, engineering, process, production, quality and marketing started becoming involved at design stage and worked as a team to introduce right product at right cost and at right time. These gave rise to terms like, "Concurrent Engineering" or "Simultaneous Engineering." Concurrent engineering is a systematic approach to the integrated, concurrent design of products and there related processes, including manufacture and support. This approach is intended to cause the developers, from the outset, to consider all elements of the product life cycle from concept through disposal, including quality, cost,

schedule, and user requirements. There are many internal and external technical, human and legal factors that put increasing pressure on the Concurrent Engineering team when designing a new product. Design for manufacturing or assembly (DFM or DFA) is a tool which systematically analyzes each part or sub-assembly from a manufacturing perspective.

1.2 Design for Manufacture

Design for Manufacture in the broadest sense, mean designing quality and “manufacturability” into the product and the required processes simultaneously. Manufacturability is defined as ease to manufacture any product. Any considerations related to manufacturing made during product development stage results into higher manufacturability of the product. The goals of DFM are to (i) minimize the product development cycle time, (ii) minimize the design to production transition time and (iii) minimize the number of design changes due to manufacturing difficulty.

During each phase of product development, several technical and economic decisions need to be made. The quality of the decisions often depends on the information available during design stage. Every design decision, if not considered carefully, can cost unnecessary manufacturing effort and loss. Normally, it has been found that design changes are made due to lack of information on path that product have to follow before reaching to the end user of the product i.e., manufacturing, marketing, shipping, etc. The DFM approach tries to minimize design changes and thus helps to get product to the market faster.

DFM represents a new awareness of the importance of design as the first manufacturing step. It recognizes that a company cannot meet quality and cost objectives

with isolated design and manufacturing engineering operations. DFM approach integrates the product design and process planning into one common activity and embodies certain underlying imperatives that help to maintain communication between all components of manufacturing system and permit flexibility to adapt and to modify the design during each stage of the product development. Various different DFM tools are available to accomplish the above mentioned objectives. However the only known technique that evaluates the manufactured quality of the product design is the Design for Quality Manufacturability (DFQM) approach.

1.3 Design for Quality Manufacturability

The quality manufacturability of a design is defined as the likelihood that defects will occur during its manufacture in a standard plant. Design for Quality Manufacturability (DFQM) is an approach involving the activities of product design, manufacturability analysis, process design and quality management for the efficient design of products that have a very low or almost no chance of producing defects. The main objective of DFQM is to enable user to improve the design so as to reduce the likelihood of defective product being manufactured.

The spectrum of quality defects by Das(1993), shown in Figure 1.1 illustrate the sources of quality problems while several techniques and tools are available to analyze quality defects, the design to manufacturing interface is not formally addressed. The focus of DFQM is therefore on the design to manufacturing interface, and how it effects the manufactured quality.

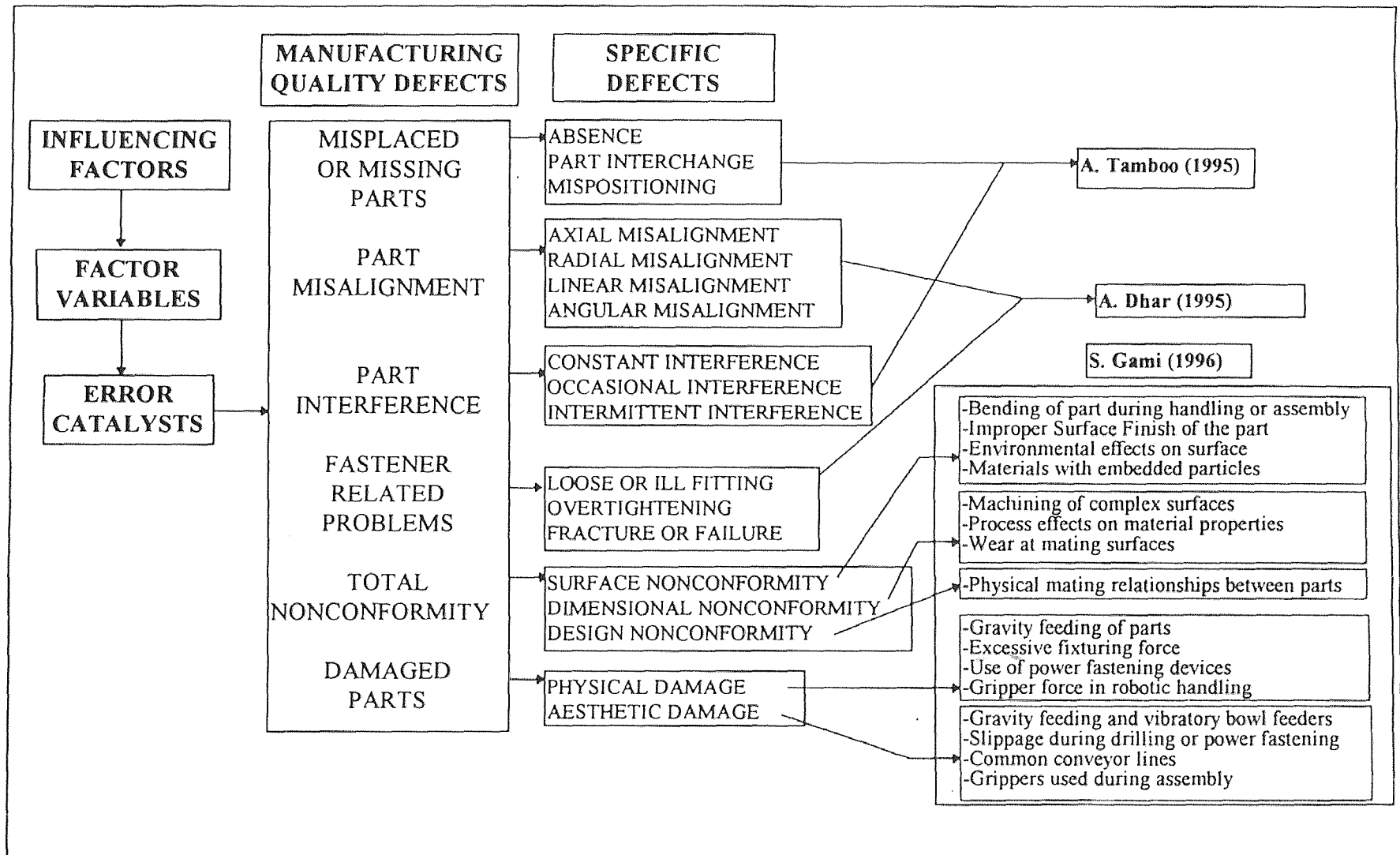

Figure 1.1 DFQM Project

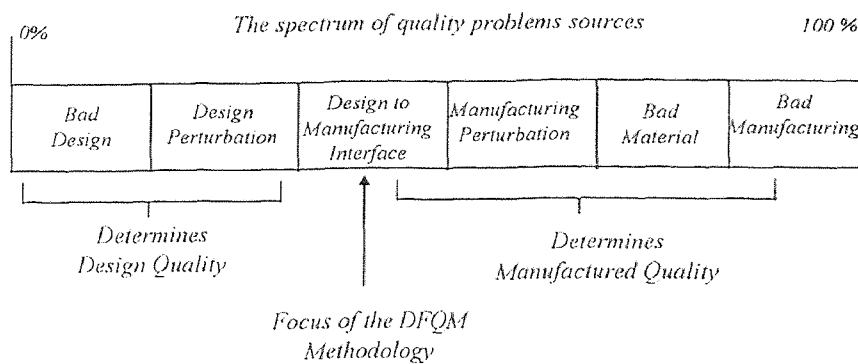

Figure 1.2 Spectrum of Quality Defects

1.4 Research Objective

This thesis forms part of a four year research which is currently underway. The research objective of this thesis is to complete the beta version of the DFQM methodology by analyzing final two defect classes total nonconformity and damaged parts. The DFQM project status is shown in figure 1.1. Concurrent development of DFQM software is supported by optimizing the inputs required for DFQM analysis. DFQM analysis is applied on an example product to illustrate the practical feasibility of the methodology.

1.5 Organization of the Thesis

The thesis consists of six chapters. The first chapter introduces the background, concepts and significance of DFM in today's industry. Chapter two gives a survey of relevant literature pertaining to DFM, Design for Assembly (DFA), and current research in DFQM. QM analysis of defect class total nonconformity and damaged part is discussed in chapter three and four respectively. DFQM analysis of a product is discussed in chapter five. Conclusions and further research in DFQM are given in chapter six.

CHAPTER 2

LITERATURE SURVEY

2.1 Quality

A large variety in products and short product life cycle, are two of the largest productivity roadblocks faced by manufacturing. It is major cause of poor quality resulting in unnecessary manufacturing cost, product unreliability, and ultimately, customer dissatisfaction and loss of market share. Variability reduction and robustness against variation of hard-to-control factors are therefore recognized as being of utmost importance in the quest for high quality products. Quality of any product can be broadly defined into two categories, namely: design quality and manufactured quality. Design quality is defined as the quality of a product as perceived by customer. On the other hand, manufactured quality is defined as the extent to which a product deviates from its design specifications.

Traditional approaches to improve the quality of the product has been focused on either monitoring the process itself or inspecting the output of the process. Deming (1988) complains that manufacturers are highly dependent on inspection as the road to higher quality, which means that they let problems occur and then try to separate the bad products. 'Prevention is better than cure' that means, manufacturers should apply problem solving methods that prevent low quality from occurring in the first place. In response to a call for quality building approaches several new methods have been reported in the literature. These approaches are widely reported in literature and most of them encourage concurrent efforts to in built a robust design. The concept practiced by Taguchi (1979), design for quality involves a three step optimization of product and process: system

design, parameter design, and tolerance design. This approach suggests that key to minimizing variability in a product's functional characteristics is to systematically select values for controllable factors such that sensitivity to uncontrollable factors is minimized. The concept of "Quality by Design" (Deming 1988, Clausing and Simpson 1990) focuses on prevention rather than problem solving.

In recent years, global competition has resulted in increased customer expectations regarding product value has given rise to new era of concurrent engineering. This gave rise to a number of approaches for developing and manufacturing high quality products and related books, literature and articles that come under title concurrent engineering.

2.2 Concurrent Engineering

Concurrent engineering (CE) combines a multi disciplinary task force, with complete specification at concept, resulting in fewer changes, thus short lead time and higher quality product. A model to improve the design by synthesizing and evaluating the design prior to production was proposed by Shingley (1963). The concurrent engineering approach is an extension of the Shingley model to enhance design techniques. An Axiomatic Approach proposed by Suh, Bell and Gussard (1978) is based upon hypothesis that there exists a small set of global principles, or axioms that can be applied to decisions made throughout the synthesis of manufacturing system including evaluation of a design decision leading to a good design. This called for a systems approach towards product design integrating all the facets of the manufacturing process. This is capitalized as the Concurrent Engineering Approach to Product Design (Das 1993).

To exploit the concept of Concurrent Engineering to the fullest extent, the products to be manufactured and assembled must be suited for the selected method and

processes. Before designing a product for manual or automated manufacture, the Concurrent Engineering team should consider good quality and ease of maintenance in mind. This concept gave rise to sub-heading under Concurrent Engineering consisting of, Design for Manufacture (DFM) techniques.

2.3 Design for Manufacture Techniques

Various different DFM techniques and related literature are available with a common aim to design a product that is easy to manufacture. The most popular and commercially available version of a generic DFM techniques is Design for Manufacture and Assembly (DFMA) developed by Boothroyd and Dewhurst (1983). This technique involves analytical tools that allow designers and manufacturing engineers to predict the manufacturing and assembly costs of a proposed product before detailed design has taken place. It computes the design efficiency by evaluating the orienting, handling, and assembly difficulty. Typical DFM process was proposed by Stoll (1988), it begins with a proposed product concept, a proposed process plan, and a set of design goals alongwith engineering data and then optimize both product and process.

Many industrial houses developed similar methodologies that are tailor made to their individual product line and business. One of the well-known method is the Hitachi Assembly Evaluation method focuses on the cost involved in handling and assembly of the parts and identifies areas of focus for efficient product assembly. The DFM calculator was developed by Westinghouse Corporation, it uses simulation techniques to analyze complex assemblies prior to their prototype production and enable designers to make changes in the design, and study the assembly process variables. The U.S. department of Navy releases a document describing two manufacturability evaluation tools, first computes Producability

Assessment Worksheet Index (PAW-I) and second one evaluates the impact of product and process variation on product quality.

Priest and Sanchez have developed an empirical methodology that evaluates manufacturability by computing the productivity index (PI) of design by considering material selection and availability, commonality and standardization, process selection, tolerancing, quality and inspection, and assembly system considerations. Malek (1985) in his study on the automatic assembly process, analyzes the repeatability of the executing organ and proposes a model to maximize the production rate of the assembly process.

2.4 Design for Quality Manufacturability (DFQM)

A salient absence of literature dealing with relationship between design and quality was observed during literature survey. The perspective of designing the DFM structure such that concrete and real manufacturing time quality problems can be addressed and quantified has not been found.

The direct relationship between the design of the product and its manufactured quality is addressed by Das (1993) and Prasad (1992). They initiated a methodology that focus exclusively on evaluating a design from the manufactured quality of the product. This can help designer in optimizing the manufacturability of the product and address multiple quality issue that could affect the product at a downstream stage. It gives designer an estimate of the quality of design from the manufactured quality perspective by giving quantitative score of his design and directing his focus on improving certain features of design in order to improve overall quality manufacturability of the product.

The general structure (Prasad 1992) of this methodology is depicted in the DFQM analysis by predicting the effect after identifying the causes. This methodology identifies a

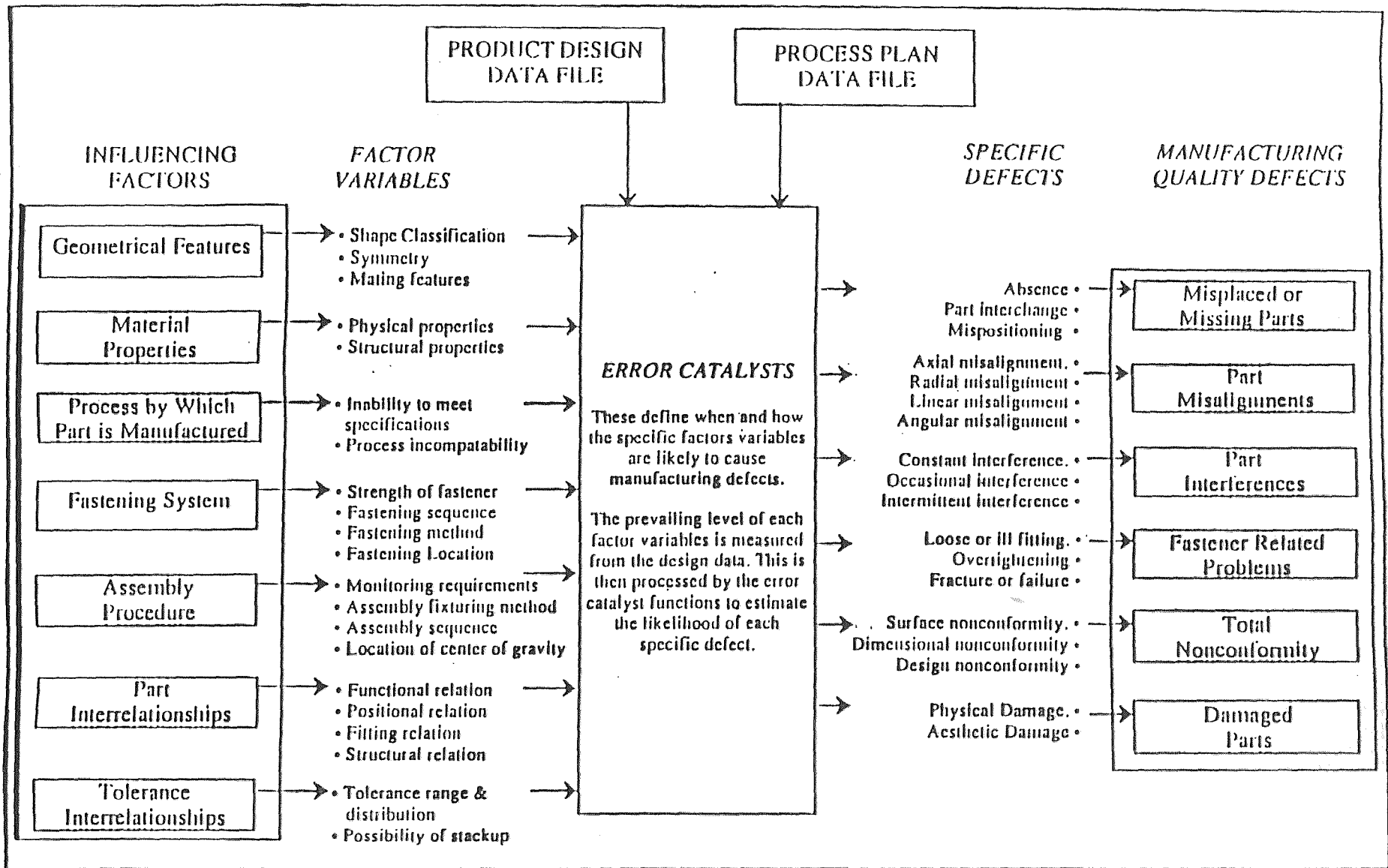

Figure 2.1 DFQM Architecture

set of defects that could occur at the assembly stage of the manufactured product. A set of factors responsible for the occurrence of these defects are also investigated. The relationships to bring about an effective link between the defects and the influencing factors is proposed in form of an error catalysts.

Suriyanarayanan (1995) studied the widely used assembly processes like insertion, riveting, welding, fastening, press-fit and snap-fit to analyze the techniques, capabilities, and limitations. Tamboo (1995) studied the defect classes missing/misplaced parts and part interference and identified the error catalysts that promotes the occurrence of these defects. Dhar (1995) specifically studied and addressed the fastener related problems and part misalignment during the assembly of the product.

2.5 Summary

Design for Manufacture approach has revolutionized the product design. The importance of design time decisions and their far reaching implications has created a lot of methodologies which can be utilized to enhance the predictive capability of the designer in terms of testability, schedulability, manufacturability, etc. Utilizing these established methodologies, designers can reduce the number of iterations traditionally involved in the design thus greatly reducing the development time.

The quality of the product has largely been reduced to a post design function. Present thought assumes that the quality of the product is independent from the design in the sense that improved manufacturability guarantees improved quality so there is little emphasis on the design for manufacturability perspective. This area is recognized for its importance and addressed in this thesis.

CHAPTER 3

DFQM ANALYSIS OF TOTAL NONCONFORMITY

3.1 Introduction

Previous research in DFQM (Dhar, Tamboo, Suri) have identified that defects found in assembled products can be classified into six basic classes. Each class of defect is a general category of defects commonly found in assembled products. These defects are related to the process through which the product is assembled. Each class of defect is further classified into various specific defects. A specific defect is a more detailed description of particular defects within each defect class. Typically, specific defects belonging to the same class will be similar in their overall effect on the quality of the product, and their general nature. They will differ in terms of what causes them, and their specific orientations. The DFQM architecture identifies six classes of defects. They are:

1. Missing or Misplaced Parts
2. Part Misalignments
3. Part Interference
4. Fastener Related Problems
5. Total Nonconformity
6. Damaged Parts

The scope of this thesis is limited to DFQM analysis of two defect classes, (i) total nonconformity and (ii) damaged parts. This chapter initially explains the logic of QM analysis and subsequently applies it to the defect class total nonconformity. Specific defect for this class of defects is identified and discussed. In chapter 4 the analysis is repeated for damaged part.

3.2 Relationship between Specific Defects, Error Catalysts and Factor Variables

The DFQM architecture as shown previously in figure 2.1, basically consist of three elements, Influencing factors, Error catalysts, and Defect classes. The manufactured quality of a product is an aggregate representation of above mentioned six classes of defects that are commonly seen in assembled products. Any attempt to assess or improve the quality manufacturability (QM) of a design is focused on this classes of defects. The occurrence of these defects is known to be influenced by several factors or characteristics that are inherent in the product's design. Most importantly, the DFQM method assumes that each of the identified factors can be quantified, and further a generally applicable error catalyst relating each factor to each defect can be developed. Error catalysts are the mechanism by which each specific factor is linked to the specific defects.

Each error catalyst is described by a graph which is similar to decision tree. This graph is used for a systematic evaluation of factor variables to determine their relative effects on the occurrence of the specific defect under study. It identifies a situation for a given design that causes specific defects to occur. Depending on the factor variables of a design, each catalysis graph leads to an index between "0" and "1", based on the relative likelihood of the error catalyst influencing the specific defect under study. A score of "0" implies better design from the quality manufacturability perspective, while score of "1" suggests worst design from the quality manufacturability perspective.

Presence of an error catalyst by itself will not induce quality defects unless certain characteristics of the design or process support it. Thus it is necessary to relate each specific defect to catalyze the occurrence of the specific defect. This needs to be done for each individual specific defect. The factor variables are linked to the error catalysts using

graphs and are given weightage based on perceived importance and relative likelihood of causing a particular defect.

Once the set of error catalysts for each class of defects and its specific defects is identified, they are used to assess the overall QM of the design. Output of the final analysis of the design using error catalysts is in form of Quality Manufacturability Matrix (QMM). It gives the relative score based on given weightage, for each individual part of the assembly for each class of defects. QMM becomes a strong tool for product designer not only to compare different design for its likelihood to cause particular defect, but also to improve design features so as to avoid occurrence of defects during its assembly stage.

3.3 DFQM Analysis of Total Nonconformity

The total nonconformity is a defect occurring due to the influence of another factor first. The effect of initial factor causes, misalignment, deformity, or fracture of the part, which then leads to this type of defect. Total nonconformity affects the functionality of the product and causes difficulty during next manufacturing or assembly stages. Total nonconformity occurs when two parts totally different in finish or size or composition cannot be assembled together at all. This defect class is further classified into three specific defects as, 1) Surface Nonconformity, 2) Dimensional Nonconformity, and 3) Design Nonconformity. The combination of certain features of design or assembly process in certain situation causes the above specific defects to occur. This combination is identified in form of few error catalysts for each of these specific defects.

3.3.1 Surface Nonconformity

Surface nonconformity is the dissension of the surfaces of two related components. It

ERROR CATALYSIS SHEET

DEFECT CLASS Nonconformity	SPECIFIC DEFECT Surface Nonconformity	SHEET NO: E-1-1
ERROR CATALYST Bending of the part during handling or assembly.		
DESCRIPTION In this error catalyst the decisive factor is the shape classification. The shape classification is done mainly based on the shape of the part. Here decisive factor turns out to be the L/D ratio or L/W ratio of the part. Also in parts with a small cross sectional areas if there are residual stresses present then as these stresses are resolved, the part undergo strain in terms of wrapping, etc. causing the surface to deform and thus undergo surface nonconformity.		
CATALYSIS GRAPH <pre> graph TD Start[START ANALYSIS] --> PG[Part Geometry] PG -- F --> C1((1)) PG -- Other --> C0((0)) PG -- "R,B,S,T" --> SC[Shape Classification] SC -- "L/D or L/W ratio ≥ 5" --> C05((0.5)) SC -- "L/D or L/W ratio ≤ 5" --> C02((0.2)) </pre>		

Figure 3.1 Catalysis Graph for the bending of part during material handling or assembly

ERROR CATALYSIS SHEET

DEFECT CLASS Nonconformity	SPECIFIC DEFECT Surface Nonconformity	SHEET NO: E-1-2
ERROR CATALYST Improper surface finish of the part.		
DESCRIPTION In the second error catalyst, if the two materials have different physical properties in terms of texture and surface grain then the same machining operation can cause the two parts to have different surface properties causing non conformity. Also if highly polished surface is required and the equipment is not able to attain the high degree of finish then the surface could become non conforming.		
		 <p style="text-align: center; font-size: small;">Magnified view of the two surfaces.</p>
CATALYSIS GRAPH <div style="text-align: center;">  <pre> graph TD Start[START ANALYSIS] --> Machining[Machining Operation] Machining -- Not done --> C0((0)) Machining -- Done --> Material[Material Properties] Material -- Different --> C0 Material -- Similar --> C1((1)) </pre> </div>		

Figure 3.1 Catalysis Graph for improper surface finish of the part

ERROR CATALYSIS SHEET

DEFECT CLASS Nonconformity	SPECIFIC DEFECT Surface Nonconformity	SHEET NO: E-1-3
ERROR CATALYST Effects of manufacturing environment on surface.		
DESCRIPTION In the third error catalyst, the surfaces requiring a high degree of finish with oxidation properties or susceptibility to corrosion the surface may get disfigured and thus become nonconforming.		
 <p>The diagram illustrates a cross-section of a surface. It shows a base layer with diagonal hatching, labeled 'Nonconformity'. Above this base layer is a thinner layer, also with diagonal hatching, labeled 'Corrosion'. Two arrows point from the 'Corrosion' label to the top surface of the corrosion layer, and one arrow points from the 'Nonconformity' label to the interface between the base layer and the corrosion layer.</p>		
CATALYSIS GRAPH <div style="text-align: center;"> <div style="border: 1px solid black; padding: 5px; width: fit-content; margin: 0 auto 10px auto;"> START ANALYSIS </div> <div style="text-align: center;"> ↓ </div> <div style="border: 1px solid black; padding: 5px; width: fit-content; margin: 0 auto 10px auto;"> Material Properties </div> <div style="display: flex; justify-content: center; gap: 20px;"> <div style="text-align: center;"> ↓ </div> <div style="text-align: center;"> → </div> </div> </div>		

Figure 3.3 Catalysis Graph for effects of manufacturing environment on surface

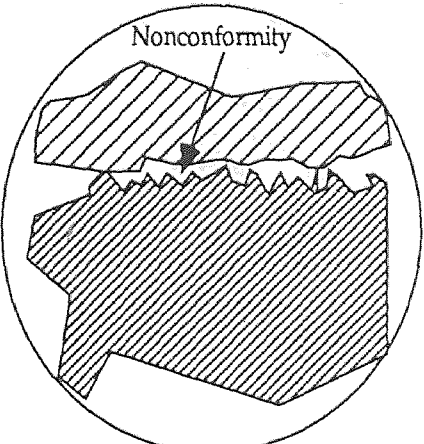
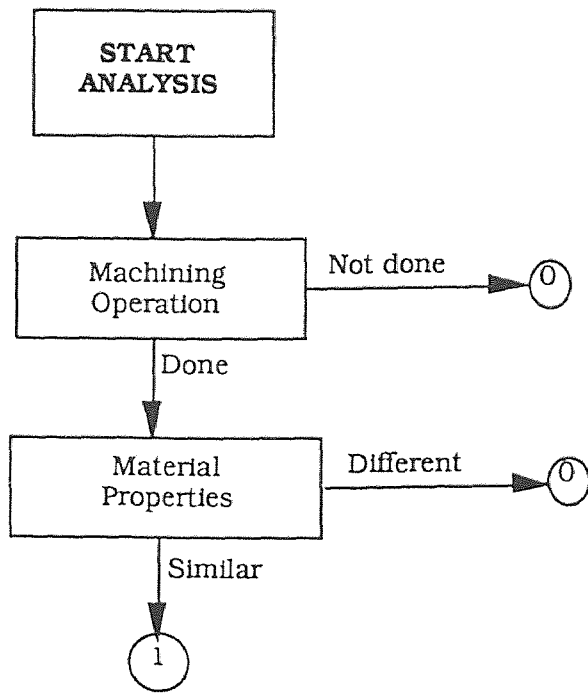
ERROR CATALYSIS SHEET

DEFECT CLASS Nonconformity	SPECIFIC DEFECT Surface Nonconformity	SHEET NO: E-1-4
ERROR CATALYST Materials with embedded particles.		
DESCRIPTION <p>In materials like polymers with embedded particles, e.g. thermoplasts, the particle size may be variable so in the absence of external pressure these unequal particles may cause the parts to be nonconforming. The physical structure of the material used plays an important role in such cases.</p>  <p style="text-align: right; margin-right: 100px;">Thermoplast</p>		
CATALYSIS GRAPH  <pre> graph TD Start[START ANALYSIS] --> PartMaterial[Part Material] PartMaterial -- Other --> O1((0)) PartMaterial -- Polymers --> Embedded[Embedded Particles Present] Embedded -- No --> O2((0)) Embedded -- Yes --> I1((1)) </pre>		

Figure 3.4 Catalysis Graph for materials with embedded particles

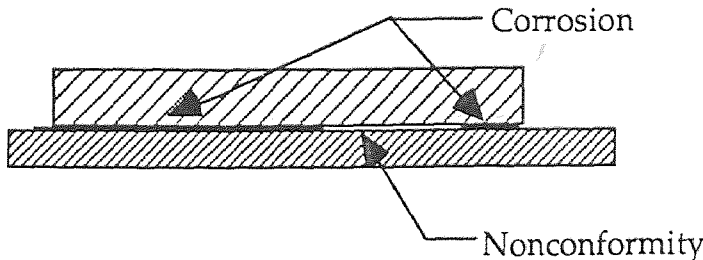
can be due to certain form of texture, grain, finish, shape, etc., of the two surfaces in contact. Surface quality of the product is one of the important criteria to judge the skill of the manufacturer. Specifically in case of automobiles and precision components, it is of absolute importance, because it not only affects the aesthetics of the product but also affects the functionality of the product. Poor surface quality of individual parts of the assembly also causes difficulty during product's final assembly stages and causes deviation from required fitting relationship between two mating parts.

Figures 3.1 through 3.4 shows four independent error catalysts that are identified as ones that influence the occurrence of specific defect surface nonconformity. They are:

1. Bending of the part during material handling or assembly.
2. Improper surface finish of the part.
3. Effects of the manufacturing environment on surface.
4. Materials with embedded particle

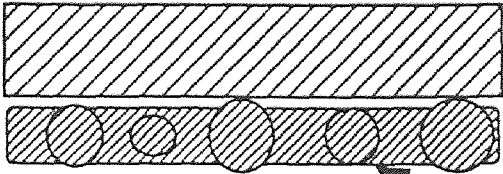
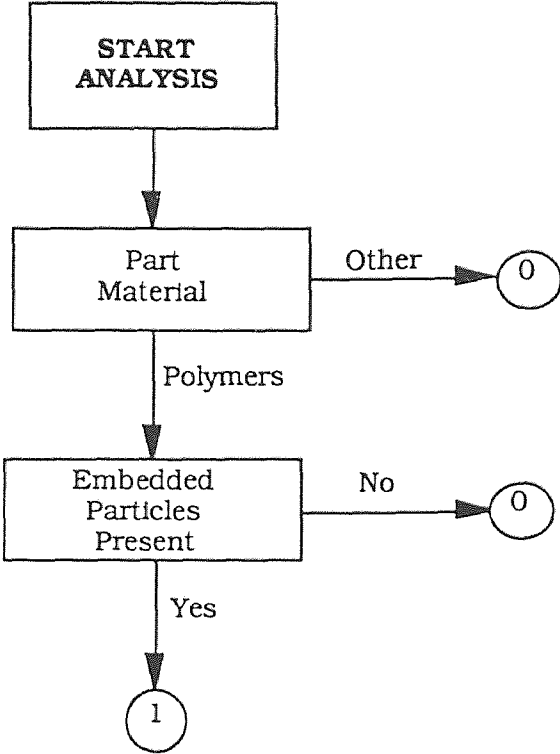
It has been observed that occurrence of this particular type of defect is dependent on various factors like its material properties, method of material handling, geometrical features of the part and process by which part is manufactured.

When parts with different material composition are assembled together, then the potential for occurrence of such defect increases. Specifically, the difference between two components could be characterized in terms of a variety of physical properties, such as shear and tensile strength, hardness, malleability, friction, and chemical resistance to corrosion. As an illustration, if two components with different material properties may not have proper mating relationship depending on the process by which part is made. Such

defects are less likely to occur if two mating parts are made up of same material or ideally with same material.

Similarly, parts with asymmetrical geometric features will have more surface nonconformity as compared to those with symmetrical geometrical features. The reason being increased complexity and process variability of the manufacturing process to manufacture asymmetrical geometric features. Also, important is the length to width (L/W) or length to height (L/H) ratio of the part or product envelope. When value of this ratio is higher, chances of bending or deviation from the original shape of the part during handling or manufacturing of the part is much higher.

It was also found that most of the time surface nonconformity occurs during the handling and storage of the part during its various manufacturing stages. The part presentation system like vibratory bowl feeder and gravity chutes can cause surface nonconformity by causing scratches or dents on the surface depending on part's material and symmetry. Finished parts with either softer materials or with heavy weight are more prone to such kind of defects rather than unfinished part.

Many times in case of parts made up of ferrous materials, surface nonconformity is found in due to environmental conditions. As an illustration, higher moisture or humidity during manufacturing can cause corrosion on surface of the parts. This is dependent on several factors like the processing cycle time, number of in-process steps before final product is ready to ship, due to improper use of cooling fluid, or due to improper part drying and storage procedures.

In conclusion, it can be said that designer should specify the widest tolerances and roughest surface that will give the required performance for operating surfaces. Also

assure that surfaces to be finish-ground are raised and never intersect to form internal corners.

3.3.2 Dimensional Nonconformity

Dimensional nonconformity occurs due to the discrepancy between the dimensions of the two related components to be mated. The dimensions are such that they may not produce misalignments, but at the same time they do not confirm to the needs of the assembly.

One important aspect of any product quality is the dimensional integrity of the product that has great effect on the quality and functionality of the product. Variation in geometrical accuracy can result from both the design and the assembly of product. Infact, dimensional variation is introduced into virtually every design when the design is manufactured. Because some manufacturing and design induced variation is inevitable, it is important to identify root causes of dimensional variation, as well as thoroughly understand the sources of variation before manufacturing the product. It has been identified that presence of certain features in design is more prone to cause dimensional variation and hence nonconformity into the product.

The dimensional nonconformity in an assembly can be primary defects or secondary defects brought about by the influence of primary defects. This can be termed as relative occurrence. The concept of relative occurrence can be defined as the influence one defect has over the occurrence of another related or unrelated defect. It has been commonly observed during assembly that the role played by each and every feature of a part increases in importance as the quality of product increases.

Any small dimensional variation in one feature of a part can bring about a change

ERROR CATALYSIS SHEET

DEFECT CLASS Nonconformity	SPECIFIC DEFECT Dimensional Nonconformity	SHEET NO: E-2-1
ERROR CATALYST Machining of the complicated surfaces.		
DESCRIPTION <p>Complicated surfaces have to be very accurately machined such that the required tolerances are achieved and the surfaces conforms to the required geometry. However due to loss of tolerance because of improper machining parameters, machine accuracy, etc. the required tolerance may not be achieved causing stackup and eventually a dimensional non-conformity. Sometimes the tight tolerances on complicated surfaces requires an extra effort in terms of labor as well as sophisticated equipment which may not be available.</p> 		
CATALYSIS GRAPH <pre> graph TD Start[START ANALYSIS] --> Geometry[Geometry Classification] Geometry -- Other --> Circle0((0)) Geometry --> Machining[Machining Operation] Machining -- Not Done --> Circle0 Machining -- Done --> Circle1((1)) </pre> <p style="text-align: center;">R4, R6, R23, B4, B6, B23, S4, S6, S23, T4, T6, T23</p>		

Figure 3.5 Catalysis Graph for machining of complicated surfaces

ERROR CATALYSIS SHEET

DEFECT CLASS Nonconformity	SPECIFIC DEFECT Dimensional Nonconformity	SHEET NO: E-2-2
ERROR CATALYST Effect of process on different physical properties of materials.		
<p>DESCRIPTION</p> <p>In mating surfaces with different physical properties especially different co-efficients of expansion, the effect of temperature may cause the two parts to expand nonuniformly, causing surface nonconformity. This change in temperature may be caused due to process itself (for e.g. heat treatment, higher temperature during machining, hot rolling, etc.). This could finally result in to improper fitting relationship between two mating surfaces.</p>		
		
<p>CATALYSIS GRAPH</p> <pre> graph TD Start([START ANALYSIS]) --> MP[Material Properties] MP -- Same --> O1((0)) MP -- Different --> RCE[Ratio of Coefficient of Expansion] RCE -- "All outside 1 +/- 0.2" --> I1((1)) RCE -- "All in 1 +/- 0.2" --> O2((0)) RCE -- "Some Within 1 +/- 0.2 And Some Without" --> TH[Time of Heating] TH -- "Prior to assembly" --> I2((1)) TH -- "Post assembly" --> FE[Do the parts have fasteners and/or positioning elements] FE -- Yes --> O3((0)) FE -- No --> I3((1)) </pre>		

Figure 3.6 Catalysis Graph for effect of process on different physical properties of materials

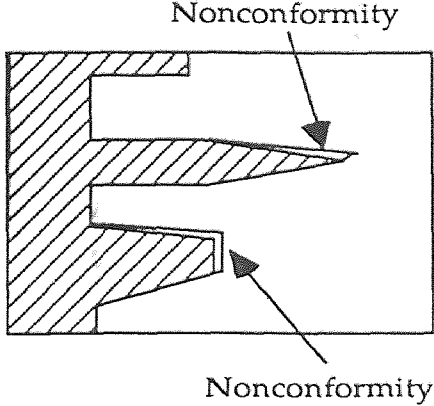
ERROR CATALYSIS SHEET

DEFECT CLASS Nonconformity	SPECIFIC DEFECT Dimensional Nonconformity	SHEET NO: E-2-3
ERROR CATALYST Wear incase of mating surfaces.		
DESCRIPTION <div style="display: flex; justify-content: space-between; align-items: flex-start; margin-top: 10px;"> <div style="width: 60%;"> <p>When two surfaces are having relative motion and have running fit then the chances of occurrence of wear increases. This kind of defect may not be visualized during initial stage of it's life but can occur when the assembly starts functioning. This results into dimensional non conformity. The positional relationship of the two components here becomes an important factor in deciding the amount of effect.</p> </div> <div style="width: 35%; text-align: center;">  </div> </div>		
CATALYSIS GRAPH <div style="text-align: center; margin-top: 20px;">  <pre> graph TD Start[START ANALYSIS] --> Q1{Relative Motion Between Parts} Q1 -- No --> C0_1((0)) Q1 -- Yes --> Q2{Positional Relationship} Q2 -- Other --> C0_2((0)) Q2 -- B1 --> C1((1)) Q2 -- A2, C2 --> C0_6((0.6)) </pre> </div>		

Figure 3.1 Catalysis Graph for wear incase of mating surfaces

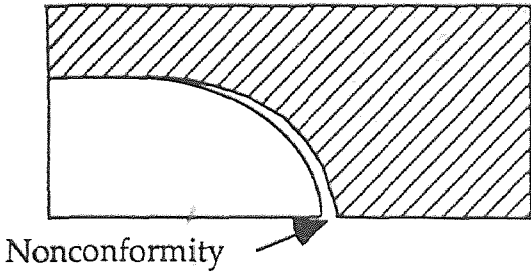
in one or more features of the adjoining or related parts. As all parts in an assembly are very closely related to each other, dimensional defect based on its magnitude in one part can become magnified and it can have a diverging effect thus increasing the defects occurring in the assembly.

Figure 3.5 through 3.7 shows the three independent error catalysts that are identified as the ones that influence the dimensional nonconformity. They are:

1. Machining of complicated surfaces
2. Effect of process on different physical properties of materials
3. Wear in case of mating surfaces

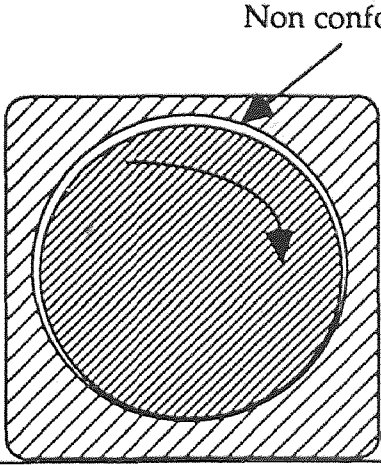
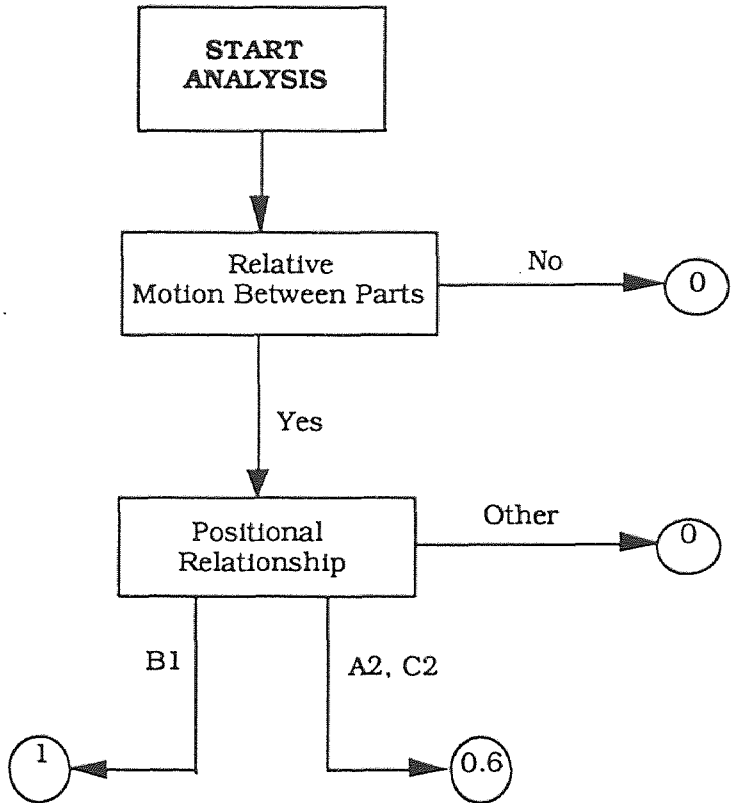
It has been observed that occurrence of this defect is dependent on factors like process by which part is manufactured, geometric features of the part and part interrelationships between different parts of same assembly.

Dimensioning and associated tolerances potentially affect assembly in many different ways:

- Prevent assembly of some of the parts
- Ensure that assembly is uniformly difficult, uniformly easy, occasionally difficult, possible, or easy for one technique or technology but not others.
- Ensure that assembly is easy by some sequences of assembly and difficult or impossible by others.

It is suggested that one must consider the relevant dimensions and tolerances on a mate-by-mate basis for the nominal design and nominal assembly sequence, assuming reasonable fixturing where appropriate. Ignorance of this consideration can sometimes result into tolerance stacking.

In case of two mating parts with materials with different coefficients of expansion, exposed to temperature variation during the process by which it is manufactured can cause dimensional nonconformity due to non uniform deformation of each component and its individual features. Such type of defects may not be noticed when part is by itself, but when both mating parts are assembled, difficulty during assembly identifies the presence of this nonconformity.

An analysis of the tolerance to which the parts are made shows, however, that properly made parts assembled one at a time could, under some combinations of tolerances, prevent proper adjustment of the last part. If it was necessary, for some reasons of cost or equipment reliability, to adopt the sequential assembly and process sequence (which does not ensure successful completion), reconsideration of part dimensions and tolerances is needed. This reconsideration may need to address part-to-part interfaces, part-to-assembly grip and jiggling interfaces, the dimensional loop of the assembly machinery, or all three.

3.3.3 Design Nonconformity

Design nonconformity occurs either due to flaw in the basic design or in the processing of the components. But this is observed when the components do not conform to the design and are noticed only in the assembly stage of the product manufacturing cycle.

In an assembled product two or more components are usually brought together, this results in a physical mating relationship between the components. Often, some of these relationships are strictly defined, and even the smallest variation could lead to nonconformity, which adversely effect the product quality. Here also, defect could initially

ERROR CATALYSIS SHEET

DEFECT CLASS Nonconformity	SPECIFIC DEFECT Design Nonconformity	SHEET NO: E-3-1
ERROR CATALYST Physical mating relationship between components.		
DESCRIPTION When two components are assembled together, eventhough the dimensions are as required between two parts, they do not function as desired. This could occur mainly due to improper mating relationship between two components and this causes design nonconformity. Typical example is 'snap-fit', here when both components to be joined are assembled, the resulting joint may be too loose or tight, and it may not function as required.		
CATALYSIS GRAPH <pre> graph TD Start[START ANALYSIS] --> Mating[Mating Condition] Mating -- "Do not exist" --> O1((0)) Mating -- "Exists" --> Fastening["Type of Fastening (Fastening Code)"] Fastening -- "Other" --> O2((0)) Fastening -- "Snap Fit" --> I1((1)) </pre>		

Figure 3.8 Catalysis Graph for physical mating relationship between components

affect each individual part of the assembly and assembly as a whole at later stage.

This type of defect is inbuilt into the design, but it is invisible until the final assembly of the product takes place. As an illustration, consider two parts fastened to each other using snap fit, shape and features of snap fit design seems to be theoretically correct but when two parts are actually made and snap fitted to each other, snap fit does not work or breaks. Several factors like, part material, part geometry, process used to manufacture this part and positional relationships can play an important part in occurrence of such defects.

Figure 3.8 shows one independent error catalyst was identified, which influence the design nonconformity. It is:

1. Physical mating relationship between components.

Here, efforts are made to identify the situation that causes, design nonconformity and assign score between 0 to 1, based on the likelihood of occurrence of such defect.

CHAPTER 4

DFQM ANALYSIS OF DAMAGED PARTS

This chapter discusses the sixth defect class of DFQM Architecture, which is damaged parts. Some of the parts or product assemblies are more likely to be damaged during the process of manufacturing due to certain features' inbuilt into product design. In this chapter, efforts are made to analyze such design features and error catalyst sheets are prepared for each of the specific defects.

4.1 DFQM Analysis of Damaged Parts

4.4.1 Damaged Parts

Damaged part is one of the quality manufacturing defect class listed into the DFQM architecture. Infact, this is the defect class that was added later on to the list of defect classes. During research, it was realized to consider a separate defect class that consists of a set of defects that causes damage to the part during its manufacturing stage. This is very commonly occurring and easily noticeable defect in any kind of product and has high impact on company's reputation and market share. Such defect occurs could occur due to two reasons, either due to bad manufacturing system as a whole or due to certain inbuilt design features, which under certain situation are more likely to cause damage to the part during its manufacturing stage. Initial analysis to identify such design features can reduce the chances of occurrence of such defects during manufacturing before actual manufacturing of the product starts. Similar approach as described in section 3.2 is used here to perform DFQM analysis of the defect class damaged parts.

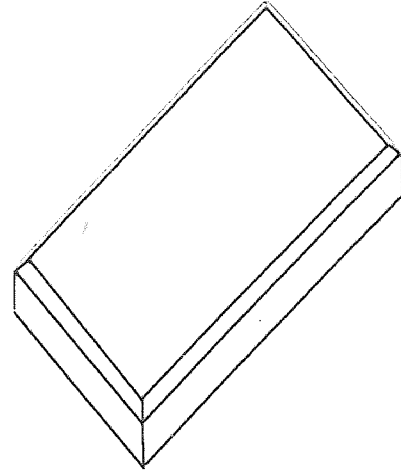
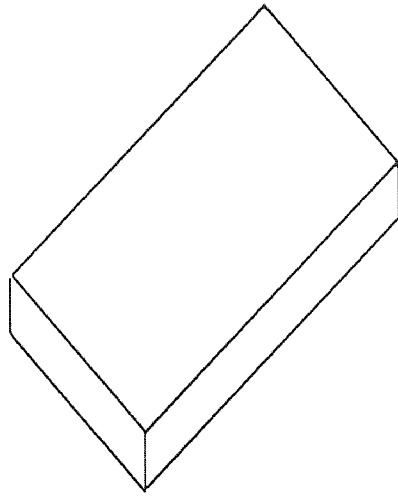

(a)

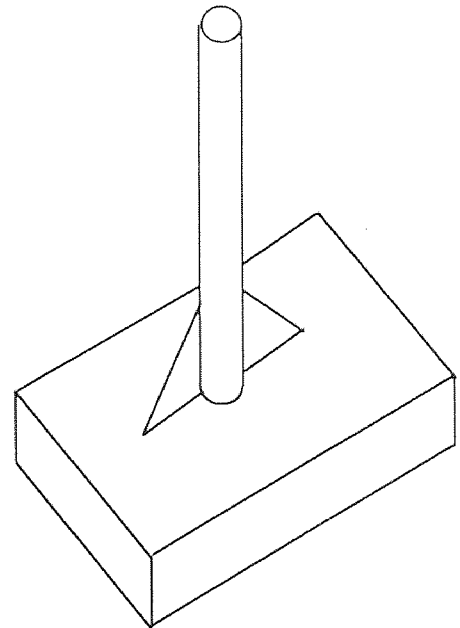
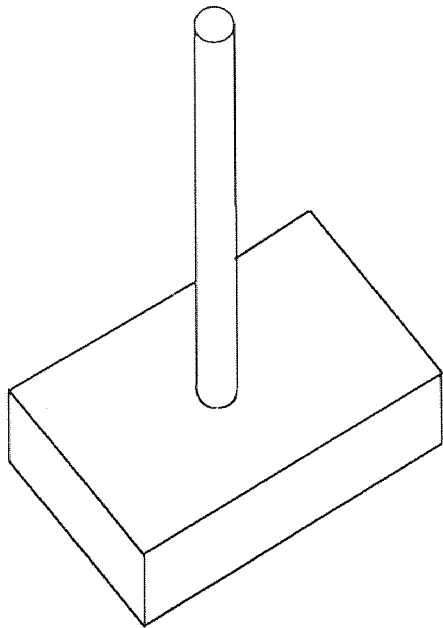

(b)

Figure 4.1 Examples of design features that causes physical damage

Considering the frequency of occurrence and intensity of damage to the part, this defect class has been distinguished into two specific defects. They are (i) physical damage, and (ii) aesthetic damage. Each of these specific defects is analyzed below and error catalysts are prepared.

4.1.2 Physical Damage

Physical damage is a defect, which affects the functionality of individual part or assembly as a whole and does not conform with the design. Majority of such defects are found in form of a breakage or crack, in one or many features of the part during manufacturing. It is caused due to combination of certain design features and poor material handling during manufacturing. Once such defects occur, they can be easily observed during its next manufacturing stage.

Some illustration design features that are more likely to cause this defect are shown in figure 4.1. One of the illustration shows two parts, one with sharp corners and edges, while other one with chamfer, and it was found that parts with sharp corners and edges are more likely to become damaged as compared to one with chamfer or radius on their edges. Such damage could cause problems during assembly, when this part mate with another part it could result into improper fitting relationship. Second illustration also shows similar design feature.

During the analysis such design features are identified and relative score between “0” to “1” is assigned based on its likelihood to cause such defects. Figure 4.2 through 4.5 shows four independent error catalysts that are identified as the ones that influence the specific defect physical damage. They are:

ERROR CATALYSIS SHEET

DEFECT CLASS Damaged Parts	SPECIFIC DEFECT Physical Damage	SHEET NO: F-1-1
ERROR CATALYST Gravity feeding of parts.		
DESCRIPTION Gravity feeding of parts made up of soft metal from a considerable height may damage the parts. Depending on their configuration, the parts may bend or the edges might get chipped off. Here, physical strength of the material used for the parts will determine the likelihood of occurrence of this defect. Also the way in which these parts are fed into the feeder can influence the defect.		
CATALYSIS GRAPH <pre> graph TD Start[START ANALYSIS] --> Handling[Type of Material Handling] Handling -- Other --> Node0((0)) Handling -- "Gravity Feeding and/or Bulk Handling" --> Material[Part Material] Material -- Al and Cu --> Node09((0.9)) Material -- Plastic --> Node06((0.6)) Material -- Hard Material --> Node0((0)) </pre>		

Figure 4.2 Catalysis Graph for gravity feeding of parts

ERROR CATALYSIS SHEET

DEFECT CLASS Damaged Parts	SPECIFIC DEFECT Physical Damage	SHEET NO: F-1-2
ERROR CATALYST Excessive fixturing force.		
DESCRIPTION Excessive fixturing force used to hold parts during assemblies may bend parts causing defective assembly. Here the geometry of the parts plays an important role. If length to breadth ratio of the part is more than 2, then this defect is likely to occur if the part is held across it's length. Physical strength of material used for the parts and fixture will determine the likelihood of occurrence of this defect. The method of fixturing and the magnitude of fixturing force used will influence this defect.		
CATALYSIS GRAPH  <pre> graph TD Start[START ANALYSIS] --> Shape[Shape Classification] Shape -- "L/D or L/W < 2" --> Circle0_1((0)) Shape -- "L/D or L/W > 2" --> Hold[Part is hold across the length] Hold -- "No" --> Circle0_2((0)) Hold -- "Yes" --> Circle1((1)) </pre>		

Figure 4.3 Catalysis Graph for excessive fixturing force

ERROR CATALYSIS SHEET

DEFECT CLASS Damaged Parts	SPECIFIC DEFECT Physical Damage	SHEET NO: F-1-3
ERROR CATALYST Use of power fastening devices.		
DESCRIPTION <p>Power fastening devices used on soft metal parts, plastic parts or particle boards may damage the parts. This type of defect is more likely to occur in case of parts made of softer materials. The method used to apply the fastener becomes the decisive factor in influencing this type of defects. Chances of occurrence of such defects are high when fastener is applied manually or with a power driven fastening device without preload features rather than one with preload features.</p>		
CATALYSIS GRAPH <pre> graph TD Start[START ANALYSIS] --> Fastening[Fastening Code (Application of Fastener)] Fastening -- "D1 or D3" --> Circle0((0)) Fastening -- "D2" --> Material[Material Type] Material -- "Rubber" --> Circle09((0.9)) Material -- "Al, Cu, Sb" --> Circle07((0.7)) Material -- "Plastic" --> Circle05((0.5)) Material -- "Other" --> Circle0((0)) </pre>		

Figure 4.4 Catalysis Graph for use of power fastening devices

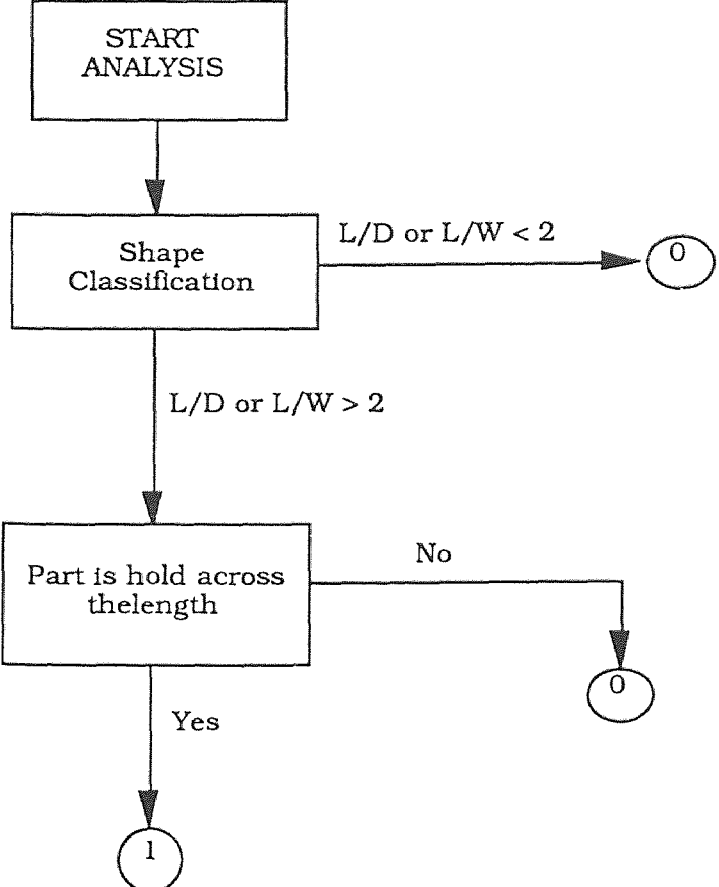
ERROR CATALYSIS SHEET

DEFECT CLASS Damaged Parts	SPECIFIC DEFECT Physical Damage	SHEET NO: F-1-4
ERROR CATALYST Gripper force in case of robotic handling.		
DESCRIPTION This defect can occur when robots are used in an assembly line for pick-and-place or for assembly itself. If the gripper force of robot is higher than what the part can withstand, it is likely to damage the part. The chances of such defect increases if the part is being gripped on it's weaker surface or edge. Physical strength of material used for the part will determine the likelihood of occurrence of this defect. Also orientation of the part during robotic handling play an important role.		
CATALYSIS GRAPH <pre> graph TD Start[START ANALYSIS] --> AM[Assembly Method] AM -- Other --> O1((0)) AM -- Robotic Assembly --> MT[Material Type] MT -- Rubber --> R((0.9)) MT -- "Al, Cu, Sb" --> A((0.7)) MT -- Plastic --> P((0.5)) MT -- Other --> O2((0)) </pre>		

Figure 4.5 Catalysis Graph for excessive gripping force in case of robotic handling

1. Gravity feeding of parts
2. Excessive fixturing force
3. Use of power fastening devices
4. Excessive gripping force in case of robotic handling

Error catalyst one and four covers most of such defects occurring due to material handling, while other two error catalysts consider defects occurring due to excessive fastening & fixturing force. During material handling many parts are damaged during bulk handling of the parts through gravity feeding. Such defects are more likely to occur if part is made up of softer materials and has fragile structure. Improper selection and positioning of feeding and orienting devices also play decisive role in causing damage to the part.

Excessive fastening force applied by power fastening devices without preload features or manually, causes overtightening of the fastener and damages the part and fastener. Parts are sometimes damaged by fixturing devices, due to non uniform distribution or excessive fixturing force.

During the analysis, various material properties as hardness, malleability, ductility and its grain structure are also considered as one of the factor in combination with others, which causes physical damage to parts. Parts made up of brittle materials are more likely break up during manufacturing.

4.1.3 Aesthetic Damage

This is the second specific defect in defect class damaged parts. Aesthetic damage to the part is damage affects the appearance of the part without affecting functionality of the part or assembly. The intensity of damage caused to part in case of aesthetic damage is

comparatively very less and sometime it may not be observed during its next manufacturing stages. These days aesthetics have become one of the inevitable feature and tool of the product design. Due to increased competitiveness and frequency of introducing product to the market, product with right combination of functionality and aesthetics, gains the upper hand in market share.

In this, highly competitive market, each day products are pouring in at such a faster rate that in order to be competitive, product designers started adding design features in to the product, to make it more aesthetically attractive. Result of this was that product designers were driven to design a product that is not only functionally complete, but it also has an ability to attract end customers towards their product. Simultaneously, extra efforts were made during manufacturing stage to prevent occurrence of such aesthetic damage to the product and this definitely affects the cost of manufacturing. Typical illustration of this is, painting section of an automobile plant, where lots of research and development and precautions are taken to provide industry with best process for applying paint to automobiles so as to avoid external particles and scratches, which affects the aesthetics of the automobiles. Similar efforts are made in almost all industries to prevent such aesthetic damage right from the first stage of manufacturing till the product reaches the final customer.

It was observed that certain design features increases the chances of causing aesthetic damage to the product during its manufacturing stage. Figure 4.6 through 4.9 shows four independent error catalysts that are identified to influence the specific defect aesthetic damage. They are:

1. Gravity feeding or Vibratory bowl feeder

ERROR CATALYSIS SHEET

DEFECT CLASS Damaged Parts	SPECIFIC DEFECT Aesthetic Damage	SHEET NO: F-2-1
ERROR CATALYST Gravity Feeding or Vibratory Bowl Feeders.		
DESCRIPTION Material Handling and orienting devices play an important role in influencing this defect. Parts falling on each other from a considerable height during gravity feeding or parts falling back into the bowl of a vibratory bowl feeder can cause dents and scratches. Orienting devices of a bowl can cause scratches on smooth finished parts or colored parts, due to vibrations may change it's position and is forced to fit. Part made up of soft metal like Aluminium or Tin is likely to get dents. Colored and plastic part get scratches.		
CATALYSIS GRAPH <pre> graph TD Start[START ANALYSIS] --> MH[Material Handling Method] MH -- Other --> O1((0)) MH -- Gravity Feeding --> FA[Feed Angle (α)] FA -- "α < 30" --> O2((0)) FA -- "α > 30" --> MT[Material Type] MT -- Rubber --> O3((0.9)) MT -- "Al, Cu, Sb" --> O4((0.7)) MT -- Plastic --> O5((0.5)) MT -- Other --> O6((0)) </pre>		

Figure 4.6 Catalysis Graph for gravity feeding or vibratory bowl feeder

ERROR CATALYSIS SHEET

DEFECT CLASS Damaged Parts	SPECIFIC DEFECT Aesthetic Damage	SHEET NO: F-2-2
ERROR CATALYST Slippage during drilling or power fastening.		
DESCRIPTION <p>While drilling a hole or fastening screws/nuts/bolts using power driven fasteners, using improper fixtures can cause this defect. Slippage between the drilling machine and the part can occur if the part is held manually or loosely. Improper orienting of the part being drilled or fastened can influence slipping of the respective tool thus causing marks, dents, scratches on the parts which would give a bad appearance. The assembly fixturing method should be designed to check against such problems. The defect is more likely to happen in case of power driven fastening equipment due to inability of the worker to control the tool.</p>		
CATALYSIS GRAPH <pre> graph TD Start[START ANALYSIS] --> Fastening[Fastening Code] Fastening -- D1 --> O1((0)) Fastening -- D2 or D3 --> Holding[Part holding Method] Holding -- Power --> O2((0)) Holding -- Manual --> Material[Material Type] Material -- Al, Cu, Sb --> O3((0.9)) Material -- Plastic --> O4((0.7)) Material -- Other --> O5((0.2)) </pre>		

Figure 4.7 Catalysis Graph for improper fixturing during drilling or power fastening

ERROR CATALYSIS SHEET

DEFECT CLASS Damaged Parts	SPECIFIC DEFECT Aesthetic Damage	SHEET NO: F-2-3
ERROR CATALYST Comon Conveyor lines.		
DESCRIPTION Common conveyor lines, whereby finished parts are handled along with other parts with rough edges, can cause this defect on the finished parts. The unfinished edges can cause scratches or even dents depending on the mateerial of the finished parts. The material handling method used decides the occurrence of this defect. Also, parts made up of soft metal is more likely to get scratches		
CATALYSIS GRAPH <pre> graph TD Start[START ANALYSIS] --> MHM[Material Handling Method] MHM -- Other --> C0((0)) MHM -- Conveyor Line --> MT[Material Type] MT -- Other --> C02((0.2)) MT -- "Al, Cu, Sb" --> C09((0.9)) MT -- Plastic --> C07((0.7)) </pre>		

Figure 4.8 Catalysis Graph for common conveyor lines

ERROR CATALYSIS SHEET

DEFECT CLASS Damaged Parts	SPECIFIC DEFECT Aesthetic Damage	SHEET NO: F-2-4
ERROR CATALYST Grippers used during assembly.		
DESCRIPTION <p>Grippers used during automatic assembly of finished parts, if not designed properly, can cause this defect. If the gripping force is high, it can cause dents on the part. The orientation of the part during loading and unloading the fixture also influences this defect. Physical strength of material used for the parts will determine the likelihood of occurrence of this defect. Fixturing force of higher magnitude applied in a wrong direction can also cause such defect.</p>		
CATALYSIS GRAPH <pre> graph TD Start[START ANALYSIS] --> AM[Assembly Method] AM -- Other --> C0((0)) AM -- Robotic --> MT[Material Type] MT -- Other --> C02((0.2)) MT -- "Al, Cu, Sb" --> C09((0.9)) MT -- Plastic --> C07((0.7)) </pre>		

Figure 4.9 Catalysis Graph for grippers used during assembly

2. Improper fixturing during drilling or power fastening
3. Common conveyor lines
4. Grippers used during assembly

It is identified during the research that same influencing factor that causes physical damage, also affects the aesthetics of the product. But only difference is in the intensity of that particular influencing factor, higher intensity could result into physical damage to the part, while lower intensity causes aesthetic damage. Also, the process by which part is manufactured and sequence by which part is manufactured has lot to do with end quality and specially, aesthetics of the manufactured product. As an illustration, number of steps product has to follow final painting of the automobile body, affects the aesthetics of an automobile. Same is true for any other product.

Majority of the aesthetic damage was found to occur during material handling of the parts or products. When parts are fed using vibratory bowl feeder,

- scratches are found on the surface of the part
- parts with fragile structure can tangle into each other and might end up causing bending of the part
- paint on painted parts might get damaged during handling

Another major factor causing this damage is the fixture used to hold the part while any operation is performed on part. Eventhough, fixturing force may not be excessive, fixture's surface in contact with surface of part causes some kind of mark or dents on the surface of the part. Extent of this marks or dent depends very much on the intensity of fixturing force, part material and method of applying fixturing force, i.e., manual or using power. Sometimes, nonuniform distribution or lower fixturing force causes slipping of the part from the fixture that cause aesthetic damage to the part. Similar, marks or dents are found due to gripping force when robots are used to assemble the products.

CHAPTER 5

DFQM ANALYSIS OF RUBBER STAMP ASSEMBLY

5.1 Introduction

The purpose of this chapter is to illustrate an application of the DFQM method. In the initial part of the chapter we describe product assembly and typical feature of it's each individual parts. Then input data required for carrying out the DFQM analysis is collected in input data sheet. This input data is finally used to carry out the final analysis of the part and each individual part and result is shown in form of a Quality Manufacturability (QM) Index.

5.2 Rubber Stamp Assembly

This example product is a rubber stamps. This product used to put seal or stamp with variable date, month and year on paper document. Assembly consists of 11 different parts assembled manually at three different stages. Following is the description of each individual part as shown in figure 5.1 and 5.2 and it's important assembly features, based on the order in which they are assembled:

1. **Pin:** It is a cylindrical, machined part and acts as a supporting shaft member for 2 small gears, a main gear and a bracket. It is supported by a groove on housing at its both ends. Total quantity of this part in assembly is one.
2. **Main Gear:** It is a cylindrical spur gear and rotates on pin with an aim to provide a means to adjust different months. It is accompanied on it's either side by a bracket and two small gears. Belt rotating between main gear and support provides torque on the main gear. Total quantity of this part in assembly is one.

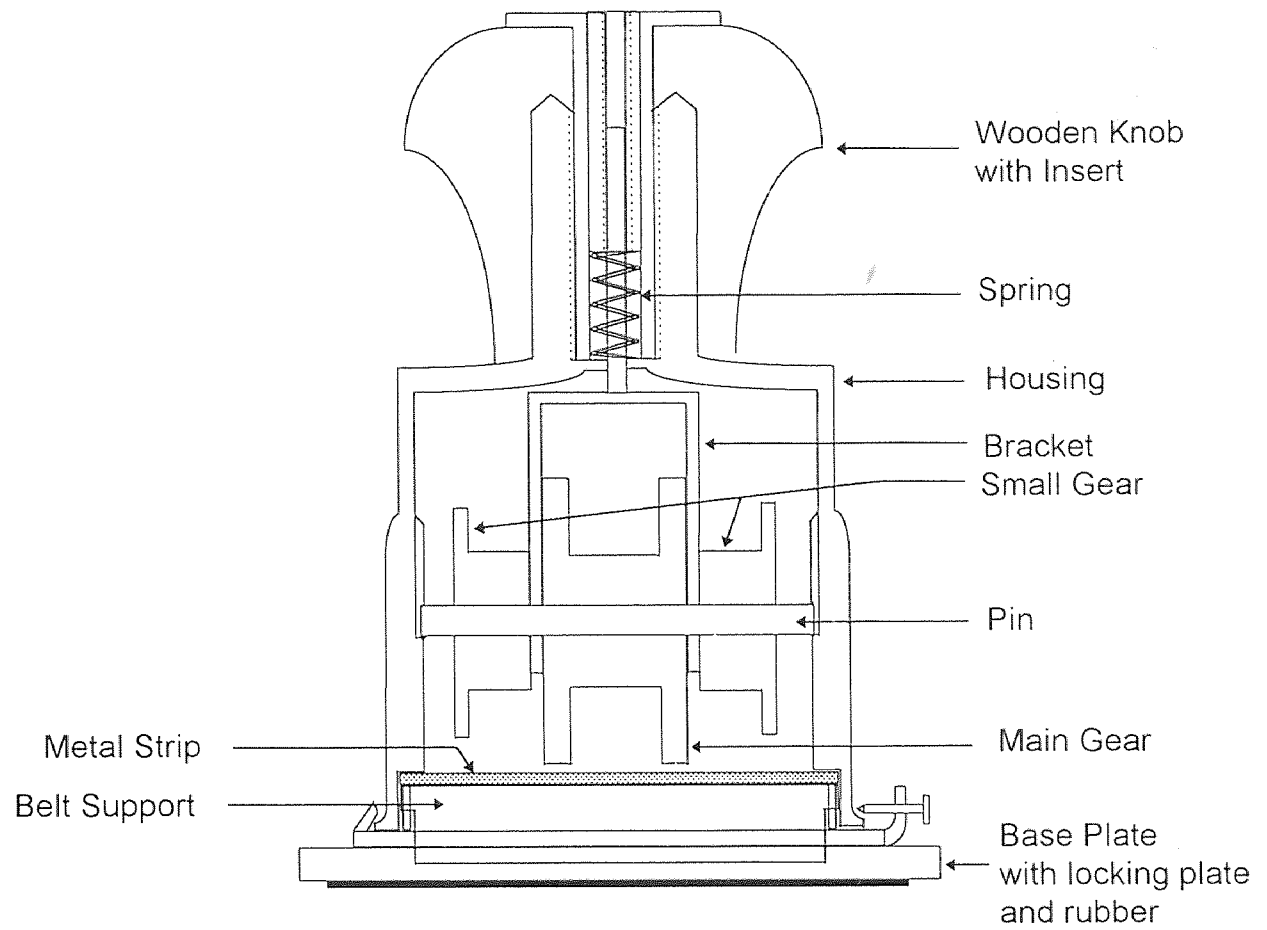

Figure 5.1 Assembly of rubber stamp

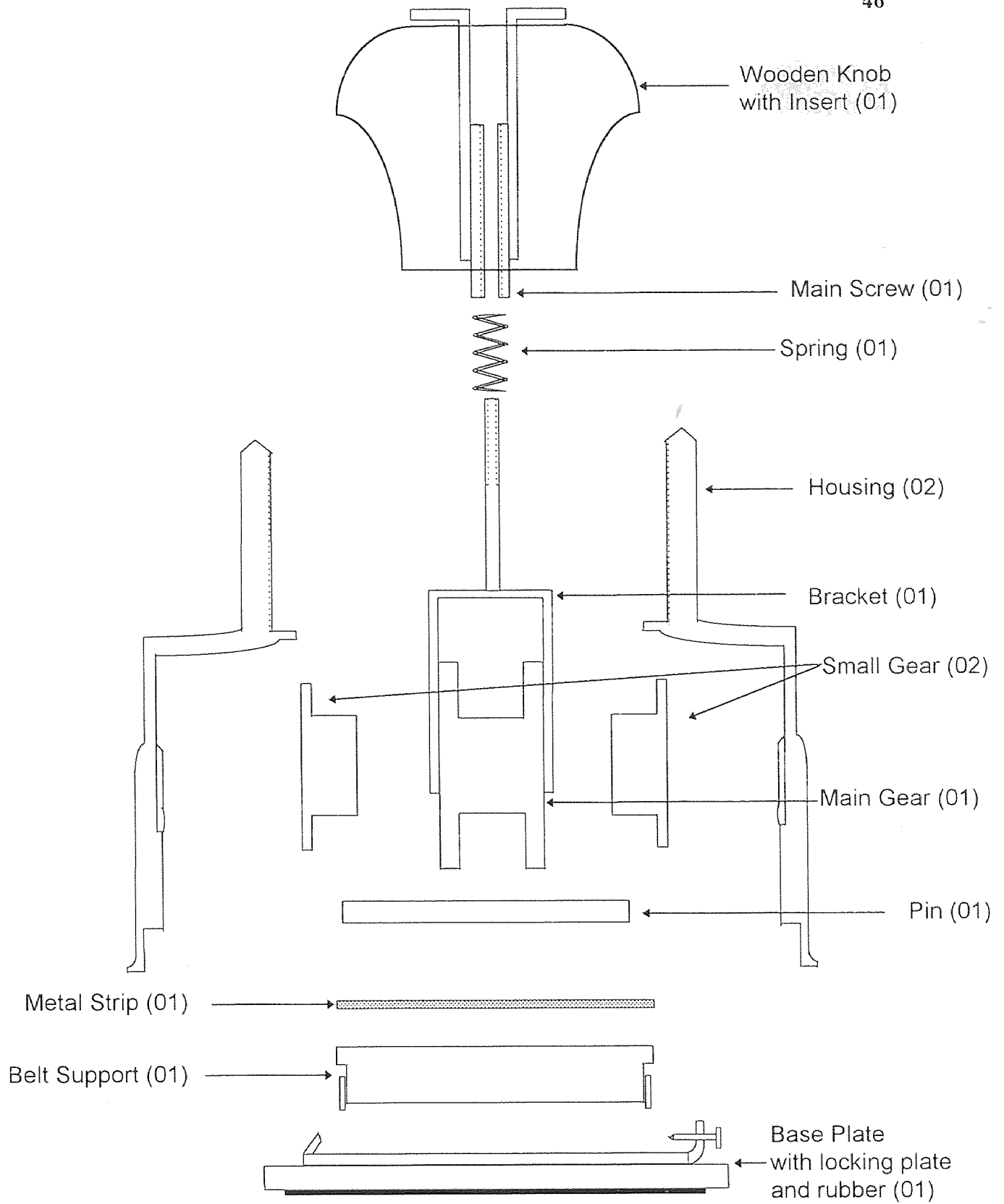

Figure 5.2 Exploded view of rubber stamp assembly

3. **Bracket:** It is a part made up of combination of a sheet metal C-section riveted to a cylindrical section with threads on it. Thus, it serves dual purpose, one to locate the main gear and second provides fastening surface for the main fastener. It is supported by a pin at the lower end and the housing at the another end. Total quantity of this part in assembly is one.
4. **Small Gear:** It is a cylindrical spur gear, assembled on either side of main gear and rotates on a pin with an aim to provide a means to adjust different date and year. Belt rotating between small gear and a support provides torque on the small gear. Total quantity of this part in assembly is two.
5. **Housing:** It is a forged component with complex shape and provides a means to keep rubber stamp assembly in place. A complete housing of an assembly is divided into two similar parts. They are located to each other by male female joint on both sides and are fastened together by inserting wooden knob on its top cylindrical part formed by two housing parts. This cylindrical top part of the housing also provides thread throughout its inner diameter for insert of the wooden knob. A male slot is provided on both sides of the housing in order to locate the wooden knob in one typical position ease the handling of the rubber stamp. Both sides of housing also provide with a slot, from which two small gear and a main gear protrude out providing a means to adjust date, month and year by rotating gear. As it can be understood from the description that, two similar parts forms one housing.
6. **Spring:** It is a flat end spring inserted on the cylindrical top portion of the bracket

and rests on C-section of the bracket. It aids in constraining the gear assembly through bracket by using main fastener. Total quantity of this part in assembly is one.

7. **Metal Strip:** It is a thin rectangular metal strip located and supported at its both ends on a slot in housing. Its main function is to provide a means to provide a stable surface for two fasteners on belt support for adjusting tension on the belts. Total quantity of this part in assembly is one.
8. **Support:** As indicated by its name, it is a rectangular part inserted inside housing on metal strip and it provides a static support for three belts. It also consists of two integral fasteners at its both ends for providing adjustment to the tensions of three belts. Total quantity of this part in assembly is one.
9. **Wooden Knob:** It is a wooden, partially spherical part inserted on the top cylindrical part of the housing. Its location is constrained by slots on both sides of the housing. It provides a means to physically keep both parts of housing and thus hold whole assembly together. Additionally, it provides a surface to hold and grip the product during its use. Wooden knob also consists of an integral insert that fastens to the inside threads of the top cylindrical part of housing. Total quantity of this part in assembly is one.
10. **Belt:** As indicated earlier, rubber belt with required imprints on it are rotated around each of the three gears to provide adjustable date, month and year. At the other end, these belts are supported by belt support. Tension can be adjusted on the belt by integral fasteners provided on the support. Total quantity of this part in assembly is three.
11. **Base Plate:** It is a square part on which the whole assembly is mounted. It consists of

three integral parts, they are main plate, locking plate and rubber. Rubber is the imprint of the required seal and is glued to the bottom of the main plate with the adhesive. Locking plate is riveted at the top of the main plate, to provide fastening and positioning of the assembly to the base plate. Total quantity of this part in assembly is one.

During the first stage of assembly, pin, bracket, belts and three gears are assembled. In second stage, housing, wooden knob, spring and main screw are added to the assembly. Finally during final stage of assembly, metal strip, belt support and base plate are assembled to complete the assembly of the rubber stamp.

5.3 Input Data For DFQM Analysis

Before analysis can take place DFQM requires user to feed with some particular data related to the product as a whole and it's individual parts. This data in turn is used by so called DFQM 'black box' to come up with the result in form of a QM matrix. Input data is designed in a way that it's optimum, easy to store it in relational database tables and use it efficiently to perform the required analysis. Table 5.1 shows the final table that consists of all input parameters that resulted after criticizing each individual input parameter. Each of these input parameters is divided into following five groups based on its characteristics:

1. **Product Data:** This group of data consists of general details regarding product, design and the user. They are entered only once before beginning analysis of any particular product design. Some typical examples of product data are design number, design name, number of parts, product dimensions, etc. Typical format of product

No.	INPUTS	SOURCE	TYPE	SING/MULTI
1	Physical Properties of material	User Input	D	S
2	Type of Fastening	Fastener Chart	D	M
3	Application of Fastener	Fastener Chart	D	M
4	Mapping Area	Fastener Chart	D	M
5	Number of fasteners	User Input	D	M
6	# of other parts sharing fastener	Fastener Chart	D	M
7	Fastening Accessibility	Fastener Chart	D	M
8	Inter Fastner Distance	Fastener Chart	D	M
9	Total # of Mating Surfaces	User Input	D	M
10	# of fasteners/# of mating surface, ratio	From (5) and (9)	I	M
11	Fastening Sequence Importance	User Input ('Y' or 'N' and #)	D	M
12	Presence of stress devices	User Input ('Y' or 'N' and #)	I	M
13	# of fasteners/# of stress devices	From (5) and (12)	I	M
14	# of fasteners in sequence/Total # of fast.	From (5) and (11)	I	M
15	# of fasteners in C4 or C5/Total # of fast.	From (5) and (7)	I	M
16	Fixturing required for fastening	Fastener Chart	D	M
17	Assembly Method	User Input	D	S
18	Rotation of end effector to position part	User Input	D	S
19	# of axis about which end efftr.would rotate	User Input	D	S
20	Fixture blocking view of any component	User Input	D	S
21	# of comp.to be assembled with hidden part	User Input	D	S
22	Positional relationship	Positional Chart	D	M
23	Maximum overlap of the two large parts("")	User Input	D	M
24	# of similar parts in assembly	User Input	D	S
25	Critical dimension of smaller part	User Input	D	M
26	Corresponding dimension of larger part	User Input	D	M
27	# of parts with congruent mating features	User Input	D	M
28	Base part orientation for insertion (Auto./ Man.)	User Input	D	M
29	Equal Inter Part Distances	User Input	D	M
30	Component Size (LxBxH)	User Input	D	S
31	Symmetry Classification Code	Symmetry Chart	D	S
32	Geometry Classification Code	Symmetry Chart	D	S
33	Relation of Mating axis w.r.t axis of symm.	User Input	D	M
34	Fitting Relationship (Press/Loose/Interm.)	User Input	D	M
35	Surface finish of hole (Smooth/Semi-fini/Unfini)	User Input	D	S
36	Type of Stress device/s (Spring/Rubb.Bushg)	User Input	D	M
37	# of constraints resisting motion	User Input	D	M
38	Presence of fastners in all the mating dirn.	User Input	D	M
39	Presence of clearance at mating site	User Input	D	M
40	Time of heating (Prior / Post Assly.)	User Input	D	M
41	Presence of wght of one part act eccentr to mat.axis	User Input	D	M
42	Fastening System Hold Position (Y / N)	User Input	D	M
43	# of fasteners parallel to mating axis	User Input	D	M
44	Direction of Mating (Opposite/Towards gravity)	User Input	D	M
45	Presence of Mating surfaces at an angle (Y / N)	User Input	D	M
46	Presence of Cantilevers	User Input	D	S
47	Part Type (Stationary / Moving)	User Input	D	S
48	Presence of contact with solid bearing part (Y/N)	User Input	D	S

Table 5.1 Input Data for DFQM Analysis

49	Presence of CG of the part to extreme end (Y/N)	User Input	D	S
50	Name of rotating part	User Input	D	M
51	Name of supporting part	User Input	D	M
52	# of supports for Shaft	User Input	D	M
53	Location of supporting surface w.r.t. shaft	User Input	D	M
54	Shaft and supp. surf. on same side of rotating part	User Input	D	M
55	Method of fastening shaft to rotating member	User Input	D	M
56	Type of shaft support(Journal/Flange)	User Input	D	M
57	Maximum dimension of hole cross-section	User Input	D	M
58	Maximum dimension of shaft cross-section	User Input	D	M
59	Type of Material Handling (Bulk/Gravity feeding)	User Input	D	S
60	Presence of flexible parts (Y/N)	User Input	D	S
61	# of locations at which flexible part is secured	User Input	D	S
62	Type of Part Motion (Linear/Rotary)	User Input	D	S
63	# of bearings for rotating member	User Input	D	S
64	Distance betn. rotating and nearest surface	User Input	D	S
65	Presence of Machining Operation	User Input	D	S
66	Presence of empedded particles (Y/N)	User Input	D	S
67	Part hold across the length while fixturing (Y/N)	User Input	D	S
68	Structural properties of material	User Input	D	S
69	# of components to be assembled at same stage, Ni			
70	# of diff. compont. types assembled at same stage, Mi			
71	# of assembly stages in bet. positioning & fastening			

Table 5.1 Input Data for DFQM Analysis

data input form is shown in appendix A. Each time user modifies the design he enters the date on which he modified the design. It consists of a data that may or may not be directly used during DFQM analysis, but might be used for reference.

2. **Part Data:** This group of data consists of details of each individual part of the product assembly. It consists of singular data that is they are not relative data but are limited to each individual part and user should be able to input this data if he has the knowledge of the process by which part is manufactured and has part drawing. This data is to be filled out for each individual part and hence is repeated for N times, where N is equivalent to the number of different parts in the product assembly. Part data consists of the details about dimensions, symmetry, material, process by which part is manufactured, its material handling, number of assembly stages after part is assembled and some details about its function in product assembly. Typical format of product data input form is shown in appendix A.
3. **Mating Relationships:** This input from user indicates the mating relationship between each part in the product assembly. Here input data is in form of an $M \times M$ matrix where M is equivalent to the number of parts in the product assembly. It is important to point out here that number of parts in the assembly (M) is different from the number of different parts in the assembly (N). Also user has to input only one side of the diagonal of the matrix, because if part number 2 mates with part number 5, then part number 5 also mates with part number 2. This group of data consists of relative data, because user should have knowledge of entire product assembly and has assembly drawing in front of him. Typical format of mating relationships' data input form is shown in appendix A. This group of data is required only once for each design and is

filled after product input data form and before individual part input data form.

4. **Mating Data:** This group of data consists of details related to mating of one part with respect to the another part in the product assembly. Hence it can be understood that this data is relative data, i.e. it applies only to the mating of one particular part relative to the other part. To input mating data, user needs detailed information about each individual part, product assembly and method by which two parts are assembled. Some typical mating data inputs are number of mating surfaces, positional relationships, functional relationships, method of fastening between two parts, etc. Typical format of product data input form is shown in appendix A. This form is filled after each part data form is filled and is repeated for X times, where X is equivalent to the number of parts that mate with the part for which part input data form was filled.
5. **Fastener Data:** This group of input data consists of details about the fastening between two mating components. Fastener data is relative data and is required for each mating relationship, if fastener is present to fasten both mating parts. Some examples of the fastener data are number of fasteners, sequence of fastening, position of fastener, ease of applying fastener, fastening code - which is based on method of fastening, type of fastener, number of parts to which fastener is applied, area of fastening, all of which is derived from the fastening table. Typical format of fastener data input form is shown in appendix A.

One of the several advantages of the DFQM approach is that for most of the inputs required, various different tables and charts have been created. For example symmetry classification chart makes it a lot easier to identify the part geometry and symmetry of each individual part of the product assembly. Some of other such charts include

positional relationship chart, fastener chart and functional relationship chart. Input data forms for rubber stamp analysis can be found in Appendix A

5.4 DFQM Analysis

Once user inputs all required data, DFQM analysis is carried out by using all groups of input data through error catalysts that is decision trees of all defect classes. The analysis is initiated based on each component of the product assembly and hence final score of the analysis is representative of score for each individual component of the product assembly.

5.4.1 DFQM Analysis of Missing/Misplaced Parts

Rubber stamp assembly is carried out manually. First specific defect class is absence of parts. Table 5.2 (a) illustrates the output data of DFQM analysis for defect class missing/misplaced parts, specific defect absence of parts and error catalyst A-1-1 i.e. manual assembly of too many similar components. The inputs used for this error catalyst are volume of the product V_o , Volume of the component V_i , number of components assembled at same stage N_i and number of different components assembled at same stage M_i . Error catalyst uses this input data to derive Y value on 0 to 1 scale, which is indicative of likelihood that particular component will be absent in product assembly due to too many similar components in the assembly. Here 0 value of Y indicates no chances of occurrence of this particular defect, while 1 value of Y indicates that defect will occur. As it can be seen from the output of Y values, components as metal strip, spring and pin are more likely to be missed during manual assembly of rubber stamp and hence have higher Y value. Similarly components like base plate, housing and wooden knob are less likely to be missed during assembly of the rubber stamp and hence have lower Y value.

Specific Defect: Absence of Parts						
Error Catalyst: Manual assembly of too many similar components						
Component Name	Volume of Product Vo	Volume of Component Vi	No. of comp. assembled at same stage, Ni	No. of different compon. assembled at same stage, Mi	Vi/Vo	Y
Main Gear	16.93	0.69	6	5	0.04	0.59
Small Gear	16.93	0.52	6	5	0.03	0.57
Pin	16.93	0.03	6	5	0.00	1.00
Bracket	16.93	0.38	6	5	0.02	0.55
Belt	16.93	0.17	6	5	0.01	0.52
Housing	16.93	2.40	4	3	0.14	0.43
Wooden knob	16.93	2.81	4	3	0.17	0.46
Spring	16.93	0.06	4	3	0.00	1.00
Belt Support	16.93	0.11	3	3	0.01	0.34
Metal Strip	16.93	0.02	3	3	0.00	1.00
Base Plate	16.93	1.35	3	3	0.08	0.36

Table 5.2 (a) DFQM Analysis of Missing/Misplaced Parts

Specific Defect: Absence of Parts						
Error Catalyst: Part falls out in interval between positioning and fastening.						
Component Name	Positioning and fastening at different stages	Positioning Relationship	Type of Material Handling	Number of stages between positioning and fastening	Vi/Vo	Y
Main Gear	Yes	B2	Manual	1	0.04	0.40
Small Gear	Yes	B2	Manual	1	0.03	0.30
Pin	Yes	B2	Manual	1	0.00	0.00
Bracket	Yes	A7	Manual	1	0.02	0.20
Belt	No	N/A	N/A	N/A	N/A	0.00
Housing	No	N/A	N/A	N/A	N/A	0.00
Wooden knob	No	N/A	N/A	N/A	N/A	0.00
Spring	No	N/A	N/A	N/A	N/A	0.00
Belt Support	No	N/A	N/A	N/A	N/A	0.00
Metal Strip	Np	N/A	N/A	N/A	N/A	0.00
Base Plate	No	N/A	N/A	N/A	N/A	0.00

Table 5.2 (b) DFQM Analysis of Missing/Misplaced Parts

Second error catalyst for this specific defect class is automatic assembly incomplete at difficult locations. Since we are assembling all components of rubber stamp manually, this error catalyst is not applicable for this product and has Y value of 0 for all its components. Third error catalyst here is part hidden by other parts of assembly equipment. Since none of the components in rubber stamp assembly requires extensive fixturing force, this error catalyst also gets Y value of 0 for all components. Error catalyst four analyses for defect when part falls out in interval between positioning and fastening. During assembly of rubber stamp, all the components assembled at first stage of assembly i.e. gears, bracket and pin are fastened during stage two and hence chances of falling apart during handling between stages are possible. Table 5.2 (b) shows the output of analysis for the above mentioned error catalyst.

Second specific defect for defect class missing / misplaced parts is part interchange. It is more likely to occur when too many similar parts are present in assembly. This is in contrast to the product assembly of rubber stamp and hence has Y value of 0 for both of its error catalysts for all components of rubber stamp assembly.

Final specific defect for defect class missing / misplaced mispositioning and occurs mainly when components with congruent mating features, lower rigidity and lack of proper positioning elements are assembled together. Since none of the components of rubber stamp assembly seems to have these features, they have Y value of 0 for all of its error catalysts. Analysis is continued for other five defect classes as per DFQM architecture by applying input data to error catalysts and Y value between 0 and 1 is derived for all components of assembly.

5.5 Output of DFQM Analysis

The final output of the DFQM analysis is derived in form of Quality Manufacturability Matrix (QMM). It is a $P \times 6$ matrix where P rows represents the number of components in assembly and 6 columns represents six defect classes. Typical example of QMM is shown in Table 5.3.

	CD1	CD2	CD3	CD4	CD5	CD6
P1	0.5	0.9	0.1	0.2	0.7	.25
P2	0.8	0.1	0.9	0.5	0.5	1.0
P3	0.5	0.2	0.7	0.9	1.0	1.0
.
.
P _L	C _{1L}	C _{2L}	C _{3L}	C _{4L}	C _{5L}	C _{6L}

Table 5.3 Quality Manufacturability Matrix (QMM)

Once Y value between 0 and 1 is received for each of the error catalysts in that defect class, intermediate QM score for particular specific defect is derived based on the relative weightage of the error catalysts of that particular specific defect. This intermediate QM score for all specific defects of a particular defect class is used to derive final QM score for that defect class and part number based on the relative weightage of specific defects. Such final QM score for each component and each defect class forms the individual cell of the QM matrix. The values shown in above table are for illustration. This matrix guides product designer to focus attention on components of assembly which are more likely to cause certain defects. At the same time, if certain defect is not perceived to

be of significant importance, depending on function of the respective part, then the defect can be ignored. This helps product designer to concentrate only on parts that are more prone to defects that are intolerable from quality and functional perspective of the product. Values of the QMM can be normalized to obtain a singular QM index for the whole assembly. This index will be on 0 to 100 scale. Higher the index, better the design from quality manufacturability perspective.

CHAPTER 6

CONCLUSION

6.1 Conclusion

This thesis completes the first version of the DFQM methodology. The error catalysts for two defect classes, total nonconformity and damaged parts derived during this thesis covers the rigidity and aesthetics aspects of design in DFQM methodology. A complete set of error catalysts for all six defects has now been completed and available for DFQM analysis. The DFQM methodology helps in bridging the gap between product design and its manufactured quality. The unique feature based analysis of product design and the assembly process exposes the strengths and weaknesses of the design from manufacturing and quality perspective.

The error catalysts derived after analysis of the final two defect classes, total nonconformity and damaged parts, complete the set of error catalysts for generic defects found in assembled products. These can now be used as a conjunction between influencing factor variables and possible defects during DFQM analysis. This concludes the effort initiated by Tamboo (1994) and Dhar (1995) to analyze the first four defect classes of DFQM architecture. Error catalyst for the damaged parts helps the product design team to optimize their efforts to introduce rigidity and aesthetics into the product design while error catalysts for total nonconformity helps to identify fundamental problems in design that results into poor quality product it is assembled.

Example of rubber stamp assembly used to test DFQM methodology helps to draw some fundamental conclusions that support the main aim of the methodology. This helped to establish that method does help to identify the features in product design that are likely

to cause the quality problems, when product is assembled in standard plant. The DFQM analysis of example also helped to optimize the inputs required for performing analysis and this supplemented the on going DFQM software development. Quantitative score obtained at the end of DFQM analysis further directs the efforts of product design team to problematic area of the design to improve the quality manufacturability of the design. This in turn substantially helps to reduce the cycle time of product development through product reaches the market.

DFQM turns out to be a unique defect-driven approach where each error catalyst is related to the defects and evaluated based of the factor variables of the design. Unique method to classify most of the input variables in tabular form further ease out the efforts of user and helps the methodology.

Concurrent efforts to transfer this methodology in form of a database software with front end in Visual Basic and back end in Microsoft Access has helped to increase the effectiveness of the DFQM methodology. This software once developed, will make it lot easier and faster to apply this methodology. These efforts have also helped to optimize the number of inputs required from user for DFQM analysis and classify them into unique functional classes. Beta version of the copy of DFQM software is expected to be ready by January 1996.

6.2 Future Research

This thesis provides with the first version of the DFQM methodology to the current DFQM research team. DFQM methodology should now be applied to larger quantity and variety of industrial products. This should initiate the process of continuously

improving the DFQM methodology and its effectiveness. The major scope of improvement is in error catalysts and input data. These efforts should be concurrent and in streamline with the software development, so that first version of DFQM software is ready by target date.

Recently, use of solid modeling and CAD packages like Pro-Engineer and SDRC's IDEAS-MS in product design has increased tremendously. This leads to logical future software development step to in-build the interface between available CAD packages and DFQM software. This will further increase the ease to use DFQM software.

Presently the methodology is limited to the assembled products, future research should also try to focus on expanding the product range to which the methodology can be applied.

APPENDIX A

NJIT
Department of Industrial and
Manufacturing Engineering

The Design For Quality Manufacturability Index.

Design Number : 222

Part ID Number: 1

Next →

← Back

Part number:	4
Mating id number:	b2
Postional code:	
Functional code:	
Number of mating surfaces:	#Name?
Fitting relationship:	
Equal inter part distances:	
Surface finish of hole:	
Time of heating:	0
Direction of mating:	
Number of constraints resisting in motion:	
Relation of mating axis w.r.t axis of symmetry:	

APPENDIX A
(continued)

NJIT

Department of Industrial and
Manufacturing Engineering

The Design For Quality Manufacturability Index

DFQM

Design Number : 202

Next →

Part ID Number: 1

← Back

Name of rotating part:	1
Name of supporting part:	2
Type of shaft support:	bearing
Method of fastening shaft to rotating member:	3
Number of supports for shafts:	2
Location of supporting surface wrt shaft:	end
Number of bearings for rotating a member:	2
Distance between rotating and nearest surface:	30.5
Max dimension of hole crosssection:	23
Max dimension of shaft crosssection:	40
Presence of cantilevers:	<input checked="" type="checkbox"/>
Shaft and support surface on the same side of rotating part:	<input checked="" type="checkbox"/>
presence of part hold across the length while fixturing:	<input checked="" type="checkbox"/>

APPENDIX A
(continued)

NJIT

Department of Industrial and
Manufacturing Engineering

The Design For Quality Manufacturability Index

DFQM

Design number : 222

Next →

Part ID Number : 1

← Back

Fastener identification number :	a2
Mating identification number :	b2
Fastening code :	
Number of fasteners :	
Number of fasteners in sequence :	
Are the stress devices present? :	<input type="checkbox"/>
Number of stress devices :	
Type of stress device present :	
Fastening operation number :	
Total number of mating surfaces :	
Inter fastener distance :	
Fastening accessibility :	
Number of other parts sharing fasteners :	
Is the fastening sequence required? :	<input type="checkbox"/>
Presence of fastening system hold position :	<input type="checkbox"/>

APPENDIX A
(continued)

NJIT

Department of Industrial and
Manufacturing Engineering

The Design For Quality Manufacturability Index

Design number : 222

Next →

Part ID Number: 1

← Back

Mating id number:	b2
Fastener id a:	
Number of flexible parts:	
Number of components to be assembled at same stage:	0
Number of different components to be assembled at same stage:	0
Number of locations at which flexible part is secured:	
Number of assembly stages in between position and fastening:	0
Number of components to be assembled with hidden part:	
Presence of clearance at mating site:	<input type="checkbox"/>
Presence of mating surfaces at an angle:	<input type="checkbox"/>
Presence of weight of one part act eccentric to mating axis:	<input type="checkbox"/>
Presence of fixture force:	<input checked="" type="checkbox"/>
Presence of fasteners in all the mating directions:	<input type="checkbox"/>
Presence of flexible parts:	<input type="checkbox"/>
Fixture blocking view of any component:	<input checked="" type="checkbox"/>

ERROR CATALYSIS SHEET

<i>DEFECT CLASS</i> Missing/Misplaced Parts	<i>SPECIFIC DEFECT</i> Absence of Parts	<i>SHEET NO:</i> A-1-1
<i>ERROR CATALYST</i> Manual Assembly of Too Many Similar Components		

DESCRIPTION

In cases of assemblies which require many similar components, there is a likelihood that the assembler misses some parts. This is likely to happen when the assembly process is monotonous leading to negligence on the part of the assembler in placing parts at various locations on the main component. Parts like washers and lock nuts are most likely to be missed. Similar, but not identical parts may get interchanged due to this. Likelihood of occurrence of such defect has been identified as a function of, ratio of component volume to the product volume, number of components to be assembled at same stage and number of different component types to be assembled at same stage.

CATALYSIS GRAPH

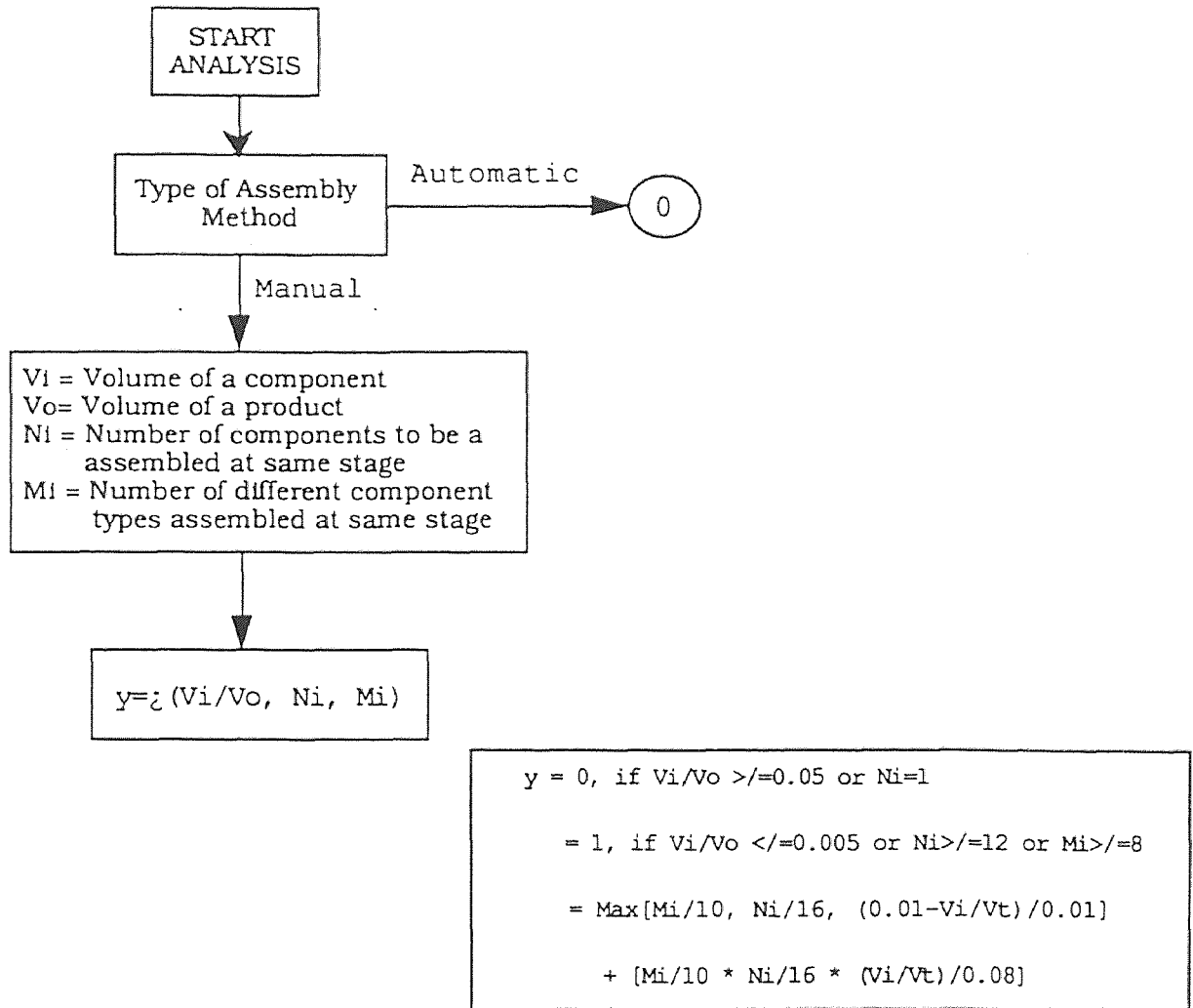

ERROR CATALYSIS SHEET

<i>DEFECT CLASS</i> Missing/Misplaced Parts	<i>SPECIFIC DEFECT</i> Absence of Parts	<i>SHEET NO:</i> A-1-2
<i>ERROR CATALYST</i> Automatic Assembly incomplete at Difficult Locations		

DESCRIPTION

In case of automatic assembly with parts to be fitted in a main component at very odd locations, some of the parts may drop before actual assembly. This may happen due to slight error in location of the main component which will consequently lead to the robot end-effector releasing the part without proper fitting. This may also happen due to error in end-effector tracking.

CATALYSIS GRAPH

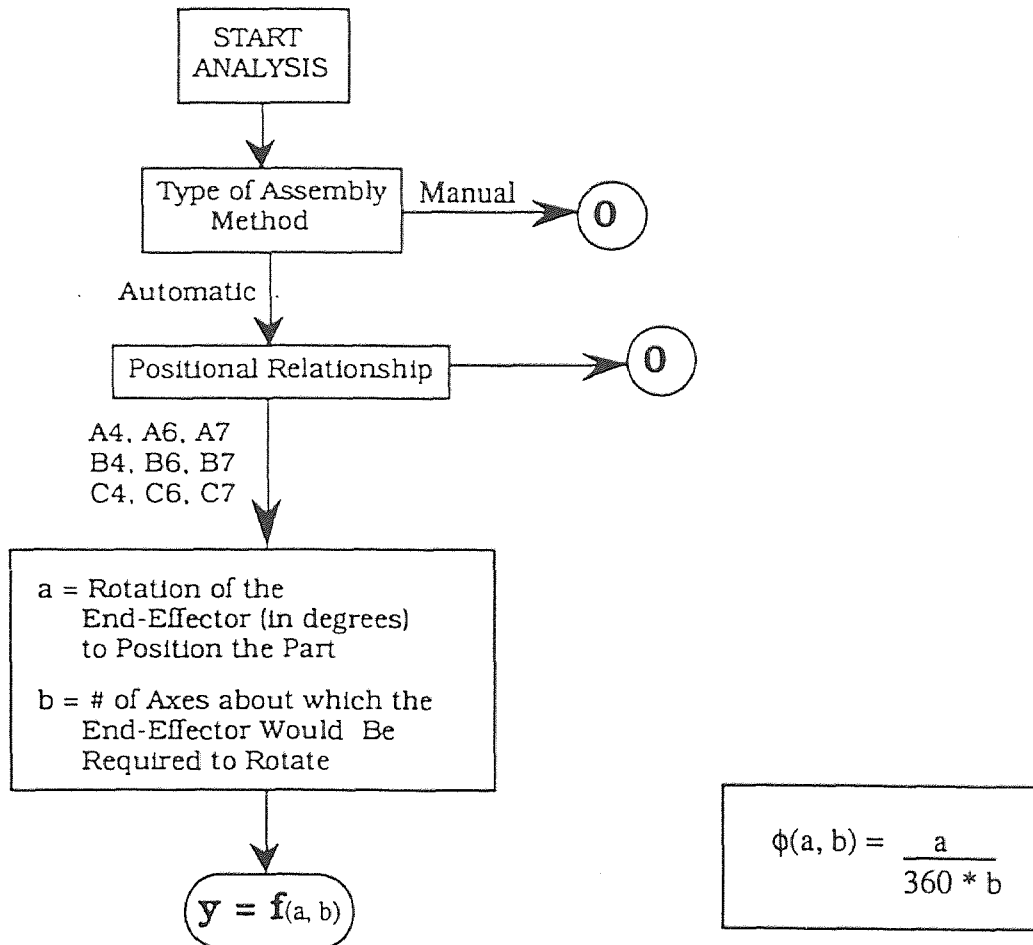

ERROR CATALYSIS SHEET

<p>DEFECT CLASS Missing/Misplaced Parts</p>	<p>SPECIFIC DEFECT Absence of Parts</p>	<p>SHEET NO:</p>
<p>ERROR CATALYST Part is hidden by other parts of assembly equipment.</p>		<p>A-1-3</p>

DESCRIPTION

The Figure shows a main block held by a fixture. Part A is located in such a spot that it is hidden under the fixture. In case of manual assembly, if the worker is assembling many other components at the same workstation, Part A is likely to be missed.

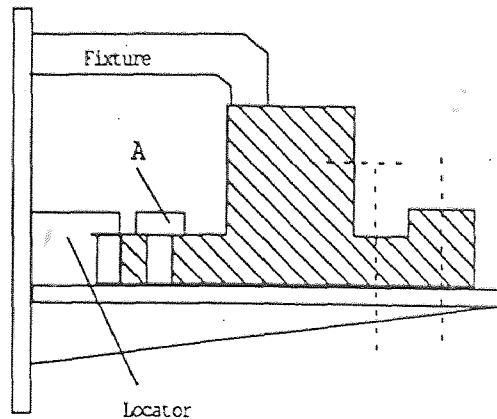

CATALYSIS GRAPH

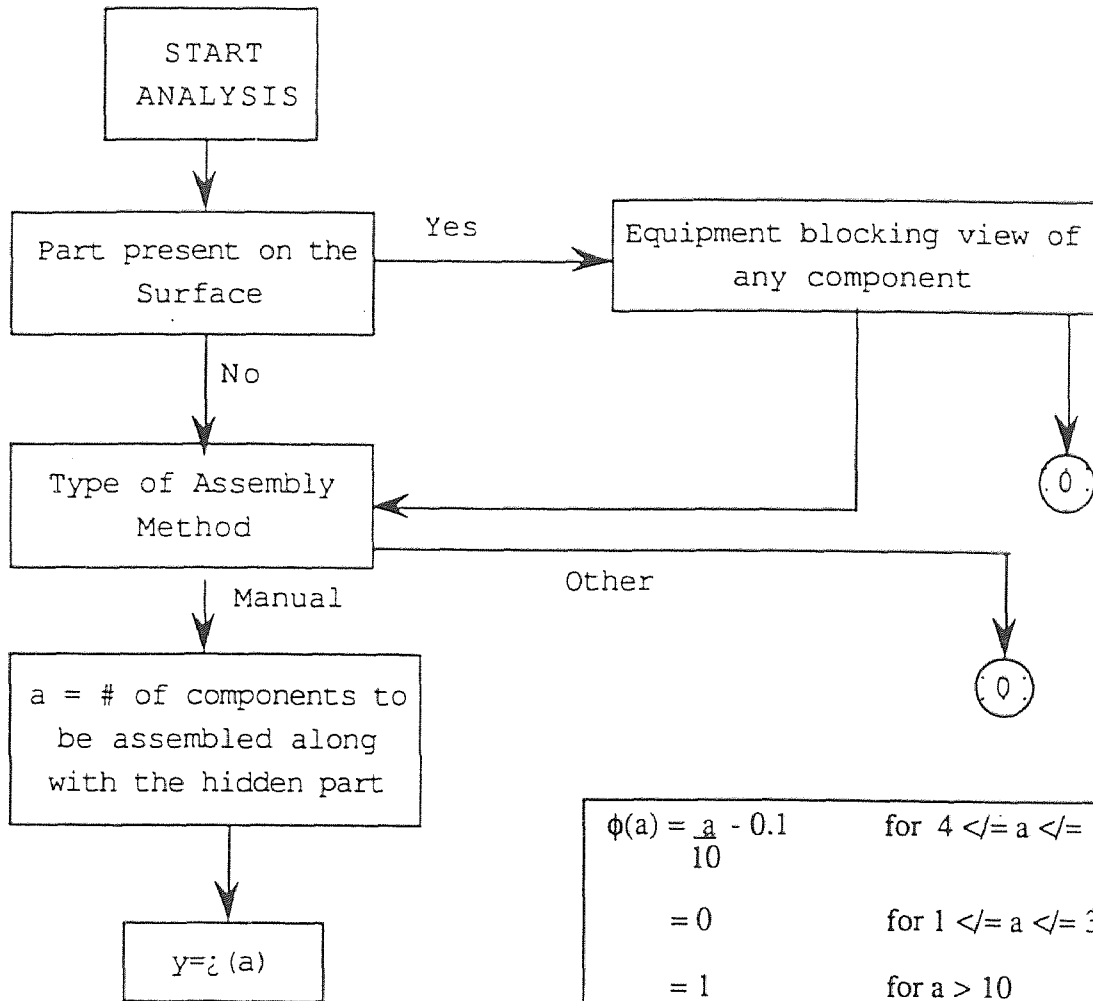

ERROR CATALYSIS SHEET

DEFECT CLASS Missing/Misplaced Parts	SPECIFIC DEFECT Absence of Parts	SHEET NO: A-1-4
ERROR CATALYST Part falls out in interval between positioning and fastening operations.		

DESCRIPTION

When positioning and fastening of a part is done at two different stages, chances are that part might fall apart before fastening is done. Amongst number of influencing factors, number of stages inbetween positioning and fastening, type of material handling inbetween two stages, positioning relationship of part with respect to assembly and ratio of volumes has significant effect on/increasing the chances of occurrence of such defect.

CATALYSIS GRAPH

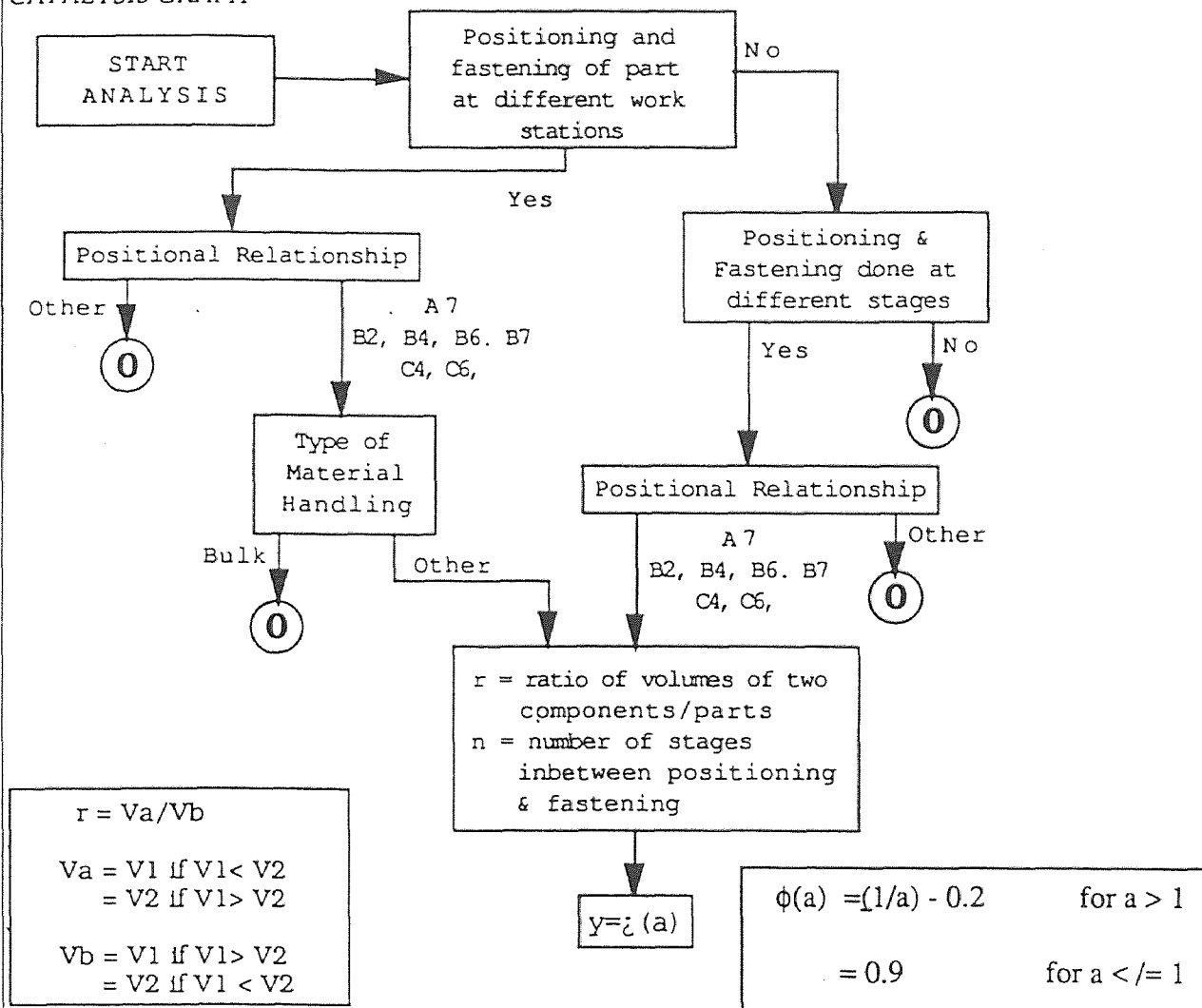

ERROR CATALYSIS SHEET

<i>DEFECT CLASS</i> Missing/Misplaced Parts	<i>SPECIFIC DEFECT</i> Part Interchange	<i>SHEET NO:</i> A-2-1
<i>ERROR CATALYST</i> Absence of Positioning Elements		

DESCRIPTION

Parts that have very similar shapes but slightly different dimensions, such that the difference is not easily noticeable, are likely to get interchanged in case of manual assembly. The figure shows one such example where the absence of anti-locating elements leads to interchange of parts. This type of defect may lead to mispositioning of subsequent components. This defect can also be avoided using assembly fixtures that check against such interchange.

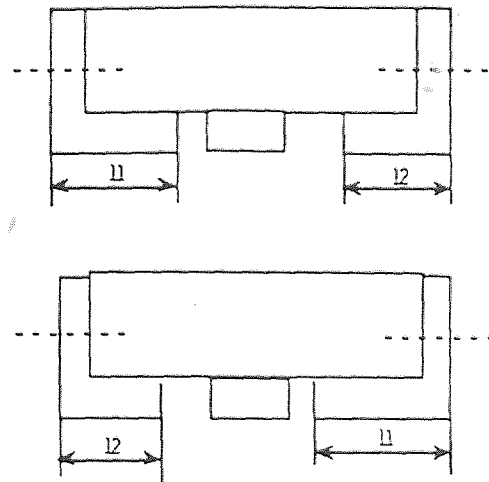

CATALYSIS GRAPH

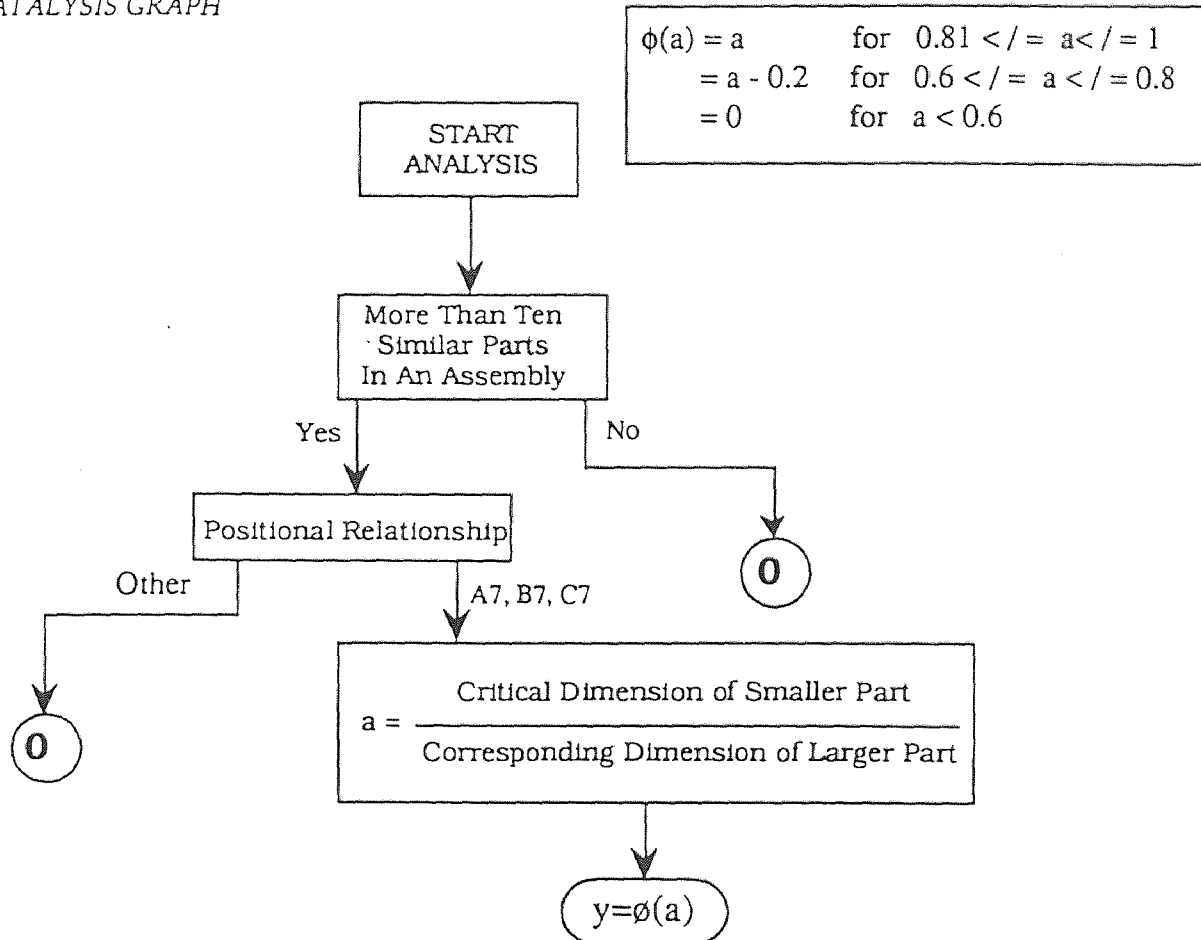

ERROR CATALYSIS SHEET

DEFECT CLASS Missing / Misplaced Parts	SPECIFIC DEFECT Part Interchanging	SHEET NO: A-2-2
ERROR CATALYST Congruent Mating Features in Automatic Fixturing		

DESCRIPTION

Part interchange can occur due to congruent mating features. This is more likely if the parts are small. For example, the assembly procedure may be such that the fixture holds the main component against Corner E. Part B and Part C are fitted first, and Part A is fitted subsequently at locations B, C, and A respectively. If all three parts have congruent mating features with the main component and if the main component is located on Corner D instead of E, Part B will fit in at location A and Part C in place of B. Furthermore, in case of automatic assembly, if the same orientation continues, Part C is likely to be absent. In case of manual assembly, Part A is likely to be fitted in place of C.

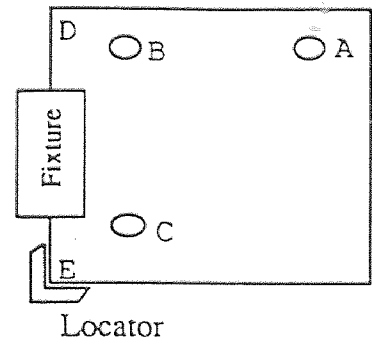

CATALYSIS GRAPH

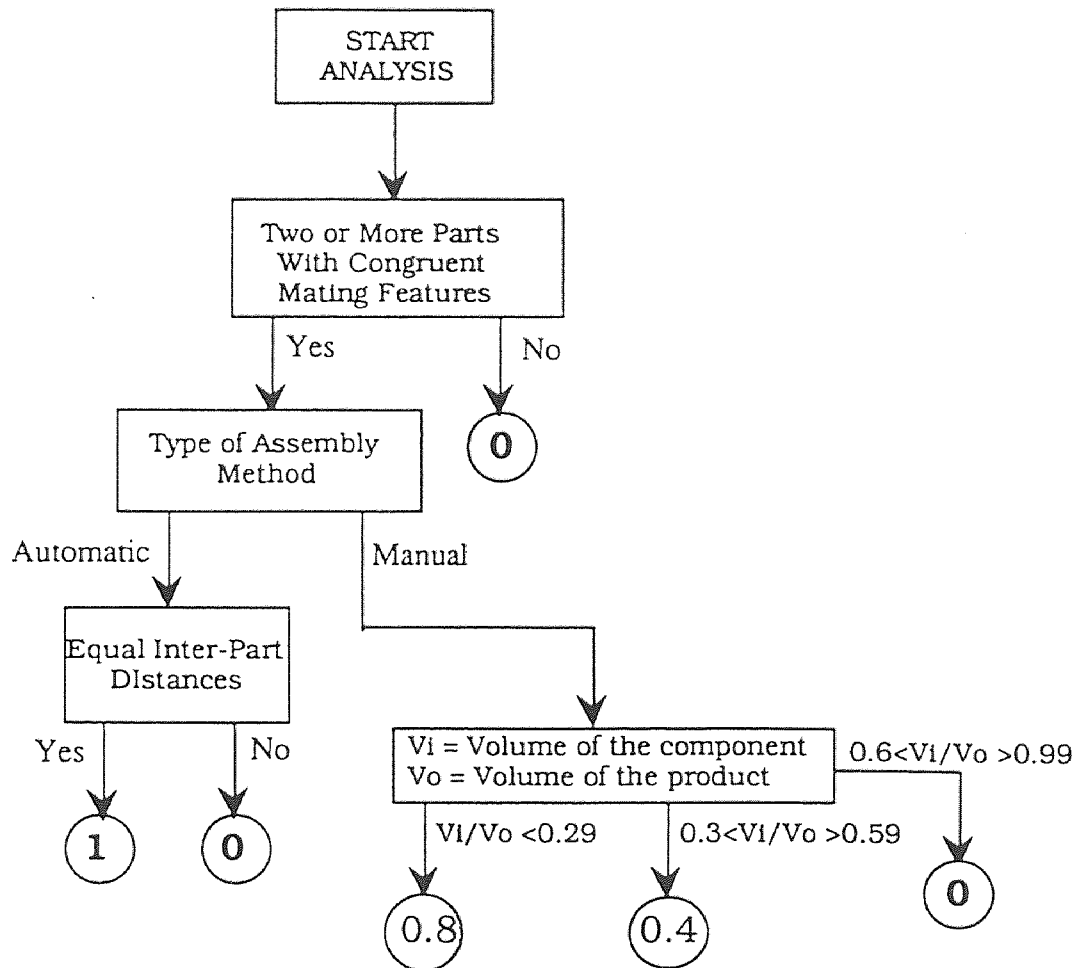

ERROR CATALYSIS SHEET

DEFECT CLASS Missing/Misplaced Parts	SPECIFIC DEFECT Mispositioning	SHEET NO: A-3-1
ERROR CATALYST Congruent Mating Features		

DESCRIPTION

Absence of positioning elements can influence mispositioning of a part with more than one congruent mating feature. This is more likely in case of manual assembly. For example, the part shown in the figure can fit the slot in two different ways. This mispositioning is likely to go unnoticed if parts have similar features. Orientation of the part shown is also difficult in case of automatic feeder.

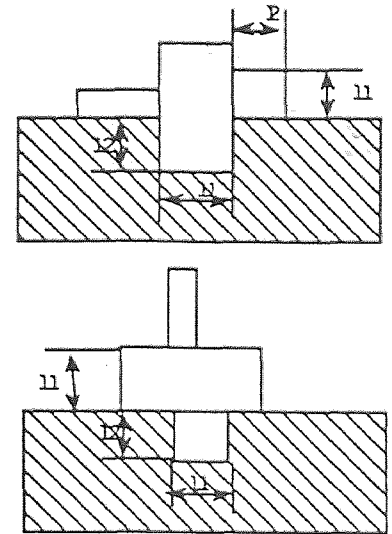

CATALYSIS GRAPH

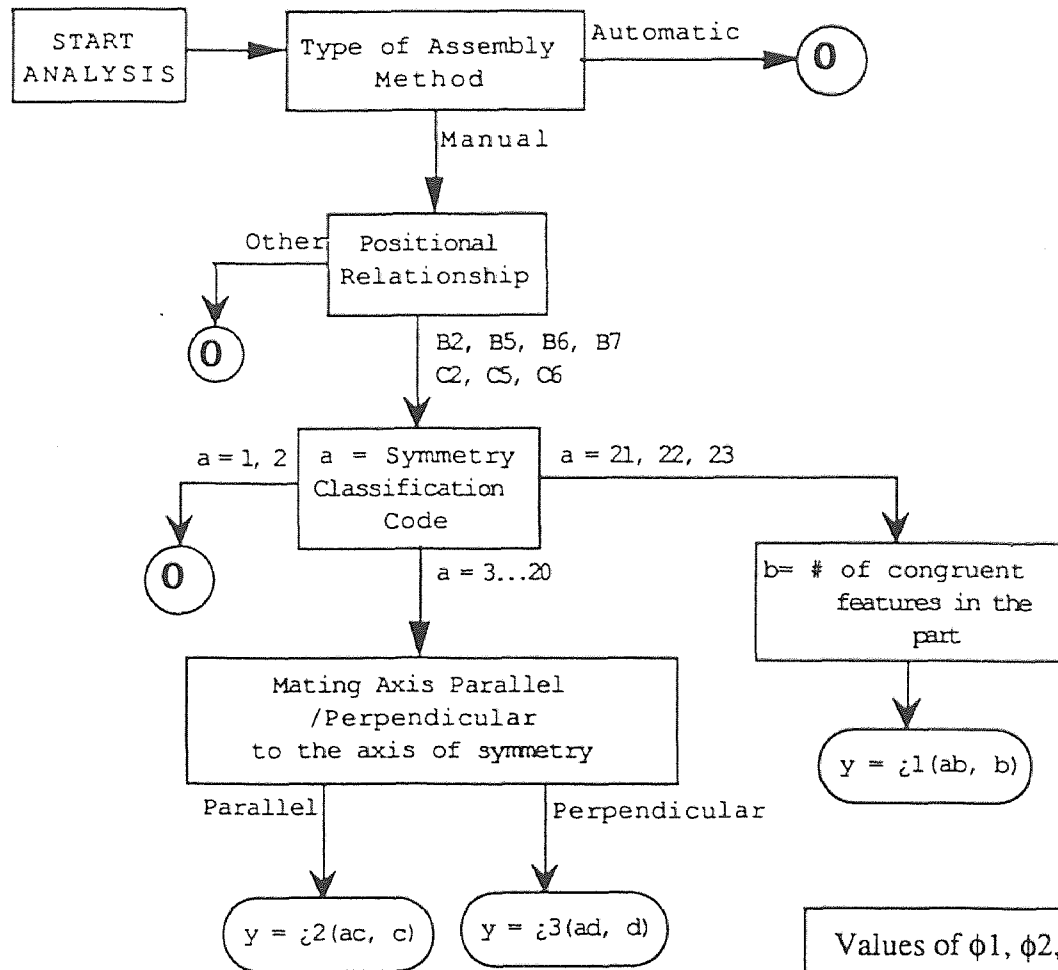

Values of ϕ_1 , ϕ_2 , and ϕ_3 are given in Table 4.2

ERROR CATALYSIS SHEET

<i>DEFECT CLASS</i> Missing / Misplaced Parts	<i>SPECIFIC DEFECT</i> Mispositioning	<i>SHEET NO:</i> A-3-2
<i>ERROR CATALYST</i> Weak parts forced into undesirable positions		

DESCRIPTION

Flat parts made of soft metal or plastic can fit in undesirable positions due to the use of power fastening devices. Geometry of the mating part plays a important role in this type of defect. The Figure shown demonstrates this defect. Under normal assembly, two lips on the part cannot fit the slots in the main component. If such a part is made of a soft material, there is a possibility that the part changes its orientation due to vibrations of a power driven fastening device and is further forced as shown. Manual fastening is not likely to cause this defect.

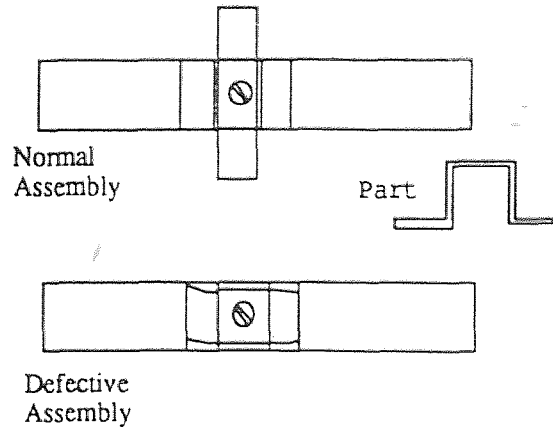

CATALYSIS GRAPH

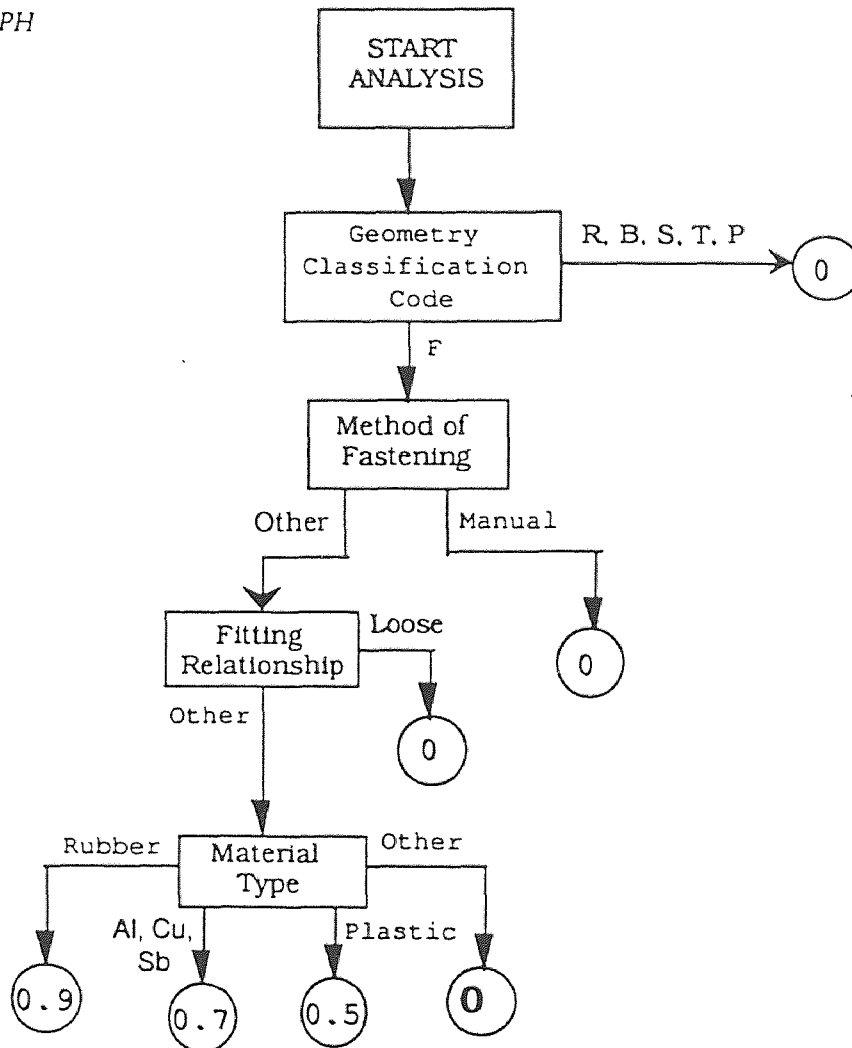

ERROR CATALYSIS SHEET

DEFECT CLASS Missing/Misplaced Parts	SPECIFIC DEFECT Mispositioning	SHEET NO: A-3-3
ERROR CATALYST Absence of Alignment Checking Features		

DESCRIPTION

Mispositioning is likely to occur if the alignment of two mating parts cannot be clearly defined. For example, the figure shows a component passing through a block. Due to the dimensions of the component and the type of mating, it cannot be easily determined if the component has fit the block as desired. If the assembly is press fitted, the length of the component required to protrude out of the block may not be met. Or, even if it is a loose or running fit, the presence of chips, burrs, or other foreign elements is likely to influence mispositioning of this type.

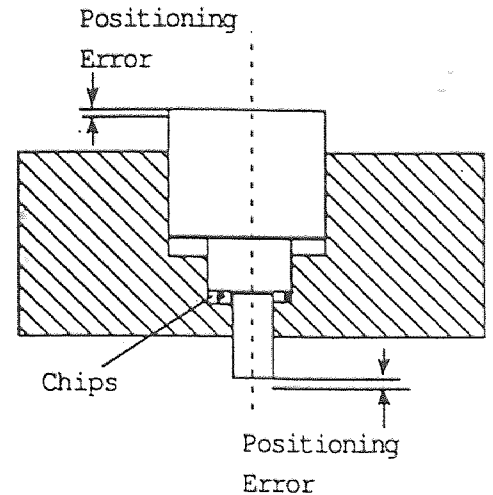

CATALYSIS GRAPH

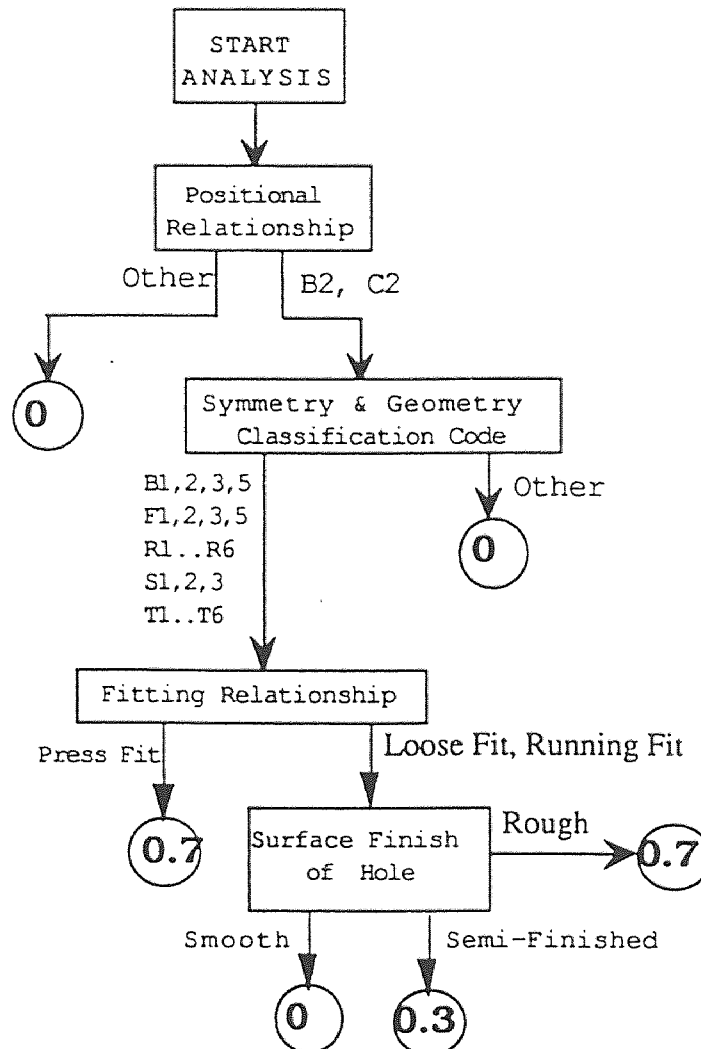

APPENDIX B
(Continued)

ERROR CATALYSIS SHEET

<i>DEFECT CLASS</i> Missing/Misplaced Parts	<i>SPECIFIC DEFECT</i> Mispositioning	<i>SHEET NO:</i> A-3-4
<i>ERROR CATALYST</i> Unfinished Surfaces		

DESCRIPTION

In certain assemblies, the surface finish of holes is not required to be smooth because it is not critical from the design perspective. The figure shows a block which has an unfinished hole. Since the hole surface has no planned contact with any mating part, the designer would not desire a finished one. This is likely to cause quality problems. For example, as shown in the figure, the spring may get mispositioned due to burrs present on hole surfaces. Distortion of the spring may lead to misalignment of the pins, or the spring may also get undesirably compressed in its initial position, disabling its function. The same reasoning also applies to rubber bushing.

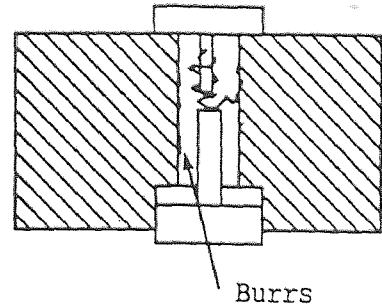

CATALYSIS GRAPH

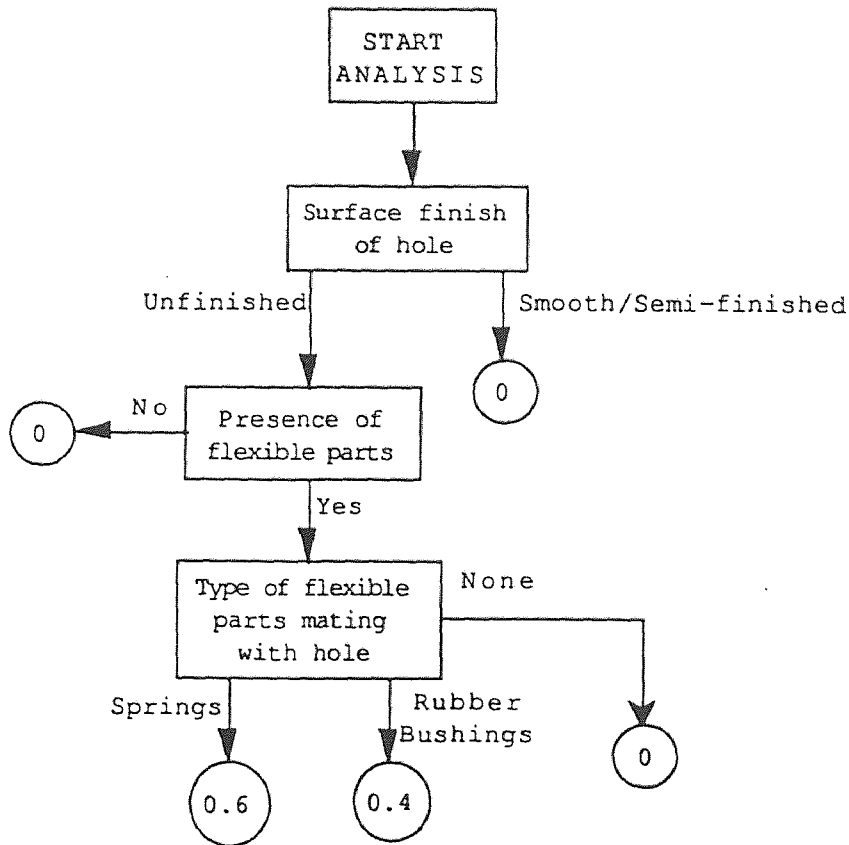

REFERENCES

- Abdel-Malek, L. "A case study on the use of robots in assembly processes" *Engineering Costs and Production Economics*, 9(1985): 99-103.
- Abdel-Malek, L. and Asadathorn, N. "On process tolerance: A brief review & models" *Engineering Economist*, (1993): 66-79.
- Boothroyd, G. and Dewhurst, P. "*Product Design for Assembly Handbook*" Wakefield, Rhode Island: Boothroyd-Dewhurst Inc., 1987.
- Boothroyd, G. and Dewhurst, P. and Knight, W. "*Product Design for Manufacture and Assembly*" University of Rhode Island, Kingston, Rhode Island: Marcel Decker, Inc., 1994.
- Ceglarek, D. and Shi, J. "Dimensional Variation Reduction for Automotive Body Assembly" *Manufacturing Review*, 8(1995): 139- 154.
- Das, S. "Design for Quality Manufacturability: An approach for improving the quality of assembled products" *IIE Transactions*, June 1991.
- Deitz, D. "Design for Quality Control" *Mechanical Engineering*, 6(1995): 60-65
- Deming, W. "*Out of crisis*" Cambridge, Massachusetts: MIT Center for Advanced Engineering Study, 1986.
- DoN Report, Producibility Measurement Guidelines: Methodology for Product Integrity, Washington, DC: Final Draft NAVSO P-xxxx, December 1991.
- Dvorak, P. "Designers get smart about manufacturing" *Machine Design*, August(1992) 101-106.
- Liggett, J. "Dimensioning sheet metal without hassle" *Machine Design*, August(1992) 46-51.
- Prasad, S. "Design for Quality Manufacturability: Formulation of Macro Architecture for DFQM Methodology" MS Thesis New Jersey Institute of Technology. June 1992.
- Shingley, J. *Mechanical Engineering Design*. 1st. ed. NY: McGraw-Hill Book Company, Inc., 1963.
- Stoll, H. "Design for Manufacture" *Manufacturing Review*, January(1988): 23-29
- Suh, N., Bell, A., and Gossard, D. "On an Axiomatic Approach to Manufacturing and Manufacturing Systems" *ASME Journal of Engineering for Industry*, 100.2(1978): 127-130.
- Youssef, M. "Design for manufacturability and time-to-market (Part 1)" *International Journal of Operations & Production Management*, 14(1994): 6-21.