



<https://theses.gla.ac.uk/>

Theses Digitisation:

<https://www.gla.ac.uk/myglasgow/research/enlighten/theses/digitisation/>

This is a digitised version of the original print thesis.

Copyright and moral rights for this work are retained by the author

A copy can be downloaded for personal non-commercial research or study,
without prior permission or charge

This work cannot be reproduced or quoted extensively from without first
obtaining permission in writing from the author

The content must not be changed in any way or sold commercially in any
format or medium without the formal permission of the author

When referring to this work, full bibliographic details including the author,
title, awarding institution and date of the thesis must be given

Enlighten: Theses

<https://theses.gla.ac.uk/>
research-enlighten@glasgow.ac.uk

**THE PRODUCTION AND EVALUATION OF MONOCLONAL
ANTIBODIES FOR HORMONE IMMUNOASSAYS**

Brian Perry FIMLS

Department of Pathological Biochemistry

Royal Infirmary

Glasgow

Thesis submitted for the Degree of Master of Science

in the

Faculty of Medicine

University of Glasgow

Scotland.

February 1992

ProQuest Number: 10992053

All rights reserved

INFORMATION TO ALL USERS

The quality of this reproduction is dependent upon the quality of the copy submitted.

In the unlikely event that the author did not send a complete manuscript and there are missing pages, these will be noted. Also, if material had to be removed, a note will indicate the deletion.



ProQuest 10992053

Published by ProQuest LLC (2018). Copyright of the Dissertation is held by the Author.

All rights reserved.

This work is protected against unauthorized copying under Title 17, United States Code
Microform Edition © ProQuest LLC.

ProQuest LLC.
789 East Eisenhower Parkway
P.O. Box 1346
Ann Arbor, MI 48106 – 1346

Thesis
9260
copy 1

GLASGOW
UNIVERSITY
LIBRARY

TABLE OF CONTENTS

	Page
TITLE	1
TABLE OF CONTENTS	2
DECLARATION	9
ABBREVIATIONS	10
PUBLICATIONS	14
LIST OF TABLES	16
LIST OF ILLUSTRATIONS	18
ACKNOWLEDGEMENTS	24
SUMMARY	26

CHAPTER ONE GENERAL INTRODUCTION

1.1.1	Introduction	28
1.1.2	The Immune System	28
1.1.3	The Humoral Immune Response	28
1.1.4	Genetic Control of the Murine Immune Response	30
1.1.5	Immunogenicity	30
1.1.6	The Structure of Immunoglobulins	31
1.1.7	Antibody Antigen Interaction	32

	Page	
1.2	PRODUCTION OF POLYCLONAL ANTISERA	
1.2.1	Introduction	34
1.2.2	The Immunogen	34
1.2.3	Choice of Adjuvant	34
1.2.4	Choice of Animal Species and Strain	35
1.2.5	Route of Immunisation	35
1.2.6	Quantity of Immunogen	35
1.3	MONOCLONAL ANTIBODY PRODUCTION	
1.3.1.	Introduction	36
1.3.2	Rationale of Cell Fusion	37
1.3.3	Choice of Cells for Fusion	38
1.3.4	Immunisation	39
1.3.5.	Fusion Protocol	40
1.3.6	Hybrid Growth and Cloning	41
1.3.7	Expansion of Cloned Hybridomas	42
1.3.8	Screening Assays	42
1.4	IMMUNOASSAY METHODOLOGY	
1.4.1	Introduction	43
1.4.2.	Saturation Assays (Radioimmunoassay)	44
1.4.3.	Immunometric Assays	45
1.4.4	Alternative Labels in Immunometric Assays	46
1.5	OBJECTIVES	49

CHAPTER TWO MATERIALS AND METHODS

2.1	MATERIALS	50
2.1.1	Equipment	50
2.1.2	Disposables	50
2.1.3	Chemicals and Reagents	51
2.1.4	Preparation of Buffers	52
2.1.5	Preparation of Standards	55
2.2	METHODS	56
2.2.1	Isolation of IgG Fractions of Antisera and Ascitic Fluids	56
2.2.2	Protein Estimation	57
2.2.3	Coupling of Antibodies to Sepharose Particles	58
2.2.4	Radioiodination Methods	59
2.2.5	Preparation of Conjugates for use as Immunogens	61
2.2.6	Immunisations	62
2.2.7	Test Bleeds	63
2.2.8	Monoclonal Antibody Production	63
2.2.9	Screening Assays	66
2.2.10	Cloning and Propagation	67
2.2.11	Freezing and Recovery of Cells	68
2.2.12	Propagation of Hybridomas <i>in vivo</i>	68
2.2.13	Isotyping of Monoclonal Antibodies	69
2.2.14	Data Reduction and Error Analysis	69

CHAPTER THREE GROWTH HORMONE

3.1	INTRODUCTION	71
3.1.1	Structure of Growth hormone	71
3.1.2	Biosynthesis of Growth Hormone	71
3.1.3	Factors Controlling Plasma Growth Hormone Concentrations	72
3.1.4	Physiological Effects of Growth Hormone	73
3.1.5	Plasma Growth Hormone Estimations in Clinical Practice	73
3.1.6	History of the Development of Growth Hormone Assays	74
3.2	MONOCLONAL ANTIBODY PRODUCTION	77
3.2.1	Immunisation and Assessment of Response	77
3.2.2	Hybridisation Experiment	77
3.2.3	Assessment of Fusion and Selection of Hybrids	77
3.2.4	Cloning and Propagation of Selected Hybrids	78
3.3	DEVELOPMENT OF AN IMMUNORADIOMETRIC ASSAY	79
3.3.1	Radioiodination of GH3/H10 Antibody	79
3.3.2	Preparation of Solid-Phase Sheep Anti-Growth Hormone	80
3.3.3	Compatibility of GH3/H10 with Sheep Anti-Growth Hormone	80
3.3.4	Preliminary Optimisation of Assay Conditions	81
3.3.5	Standardisation	81
3.4	ANALYTICAL VALIDATION	83
3.4.1	Comparison of IRMA with RIA	84
3.4.2	Internal Quality Control	84
3.4.3	External Quality Assessment	85
3.4.4	Cross Reactivity Studies	85

	Page	
3.5	CLINICAL VALIDATION	87
3.5.1	Suppression Tests	87
3.5.2	Stimulation Tests	88
3.6	CONCLUSIONS	90

CHAPTER FOUR PARATHYROID HORMONE

4.1	INTRODUCTION	92
4.1.1	Structure of Parathyroid Hormone	92
4.1.2	Biosynthesis of Parathyroid Hormone	92
4.1.3	Factors Controlling Parathyroid Hormone Concentrations	93
4.1.4	Circulating Fragments of Parathyroid Hormone	94
4.1.5	Physiological Effects of Parathyroid Hormone	95
4.1.6	Plasma Parathyroid Estimations in Clinical Practice	96
4.1.7	History of the Development of Parathyroid Hormone Assays	97
4.2	MONOCLONAL ANTIBODY PRODUCTION	100
4.2.1	Immunisations and Assessment of Response	100
4.2.2	Hybridisation Experiments	101
4.2.3	Assessment of Hybridisation Experiments	101
4.2.4	Assessment of Monoclonal Antibodies	102
4.3	DEVELOPMENT OF AN IMMUNORADIOMETRIC ASSAY	103
4.3.1	Radioiodination of Anti-PTH Monoclonal Antibodies	103
4.3.2	Preparation of Solid-Phase Anti-PTH Monoclonal Antibodies	103
4.3.3	Selection of a Complementary Pair of Antibodies	104
4.3.4	Optimisation of Assay Conditions	105

	Page	
4.4	ASSAY VALIDATION	106
4.4.1	Analytical Validation	106
4.4.2	Clinical Validation	106
4.5	CONCLUSIONS	107

CHAPTER FIVE ATRIAL NATRIURETIC FACTOR

5.1	INTRODUCTION	109
5.1.1	Nomenclature and Structure of Atrial Peptides	110
5.1.2	Biosynthesis of Atrial Natriuretic Factor	110
5.1.3	Biological Actions of Atrial Natriuretic Factor	111
5.1.4	Measurement of ANF Concentration	113
5.1.5	Plasma ANF in Pathological Conditions	114
5.2	MONOCLONAL ANTIBODY PRODUCTION	117
5.2.1	Initial Immunisations	117
5.2.2	Assessment of Response to Immunisations	118
5.2.3	Evaluation of the Screening Assay	118
5.2.4	Development of an HPLC Purification Method	119
5.2.5	Comparison of Radioiodination Methods	121
5.2.6	Further Immunisations	122
5.2.7	Hybridisation Experiments	123
5.2.8	Assessment of Fusion Experiments	124
5.2.9	Examination of the Efficiency of Separation	125
5.2.10	Assessment of Further Hybridisation Experiments	126
5.3	CONCLUSIONS	126

	Page
CHAPTER SIX ATRIAL NATRIURETIC FACTOR ASSAY DEVELOPMENT	
6.1 INTRODUCTION	129
6.2 ASSESSMENT OF ANTIBODY TITRES AND AFFINITIES	129
6.3 ASSESSMENT OF ANTIBODY COMPLEMENTARITY	130
6.3.1 Radiolabelling of Monoclonal Anti-ANF Antibodies	130
6.3.2 Coupling of Monoclonal Antibodies to Sepharose CL4B	131
6.3.3 Coupling of Polyclonal Anti-ANF (716/9) to Sepharose	132
6.3.4 Assessment of Complementarity	132
6.4 DEVELOPMENT OF A RADIOIMMUNOASSAY	133
6.4.1 Choice of Antibody Dilution	133
6.4.2 Effect of Delayed Addition of I ¹²⁵ ANF	134
6.4.3 Effect of the Mass of I ¹²⁵ Added	134
6.4.4 Coupling of Anti-ANF to Magnetic Particles	135
6.4.5 Extraction and Concentration of ANF From Plasma	136
6.4.6 Recovery of ANF From Plasma	137
6.4.7 Confirmation of Standard Potency	137
6.4.8 Effect of Oxidation State of Standards and Radiolabelled ANF	138
6.4.9 Further Examination of Plasma Extraction Procedure	139
6.5 CONCLUSIONS	140
CHAPTER SEVEN GENERAL DISCUSSION	141
REFERENCES	149

DECLARATION

The work presented in this thesis was performed solely by the author, except where otherwise acknowledged.

ABBREVIATIONS

^{125}I	radioisotope of iodine
α	alpha
Ab	antibody
Abs	absorbance
ACN	acetonitrile
Ag	antigen
ALTM	all laboratory trimmed mean
AMP	adenosine monophosphate
ANF	atrial natriuretic factor
ATP	adenosine triphosphate
β	beta
B	bound
Bq	Becquerel
BSA	bovine serum albumin
c	centi-, $\times 10^2$
CDI	carbonyldiimidazole
cpm	counts per minute
CV	coefficient of variation
DAR	donkey anti-rabbit
DELFLIA	dissociation enhanced lanthanide fluoroimmunoassay
DMSO	dimethyl sulphoxide
DNA	deoxyribonucleic acid
EDC	(1-ethyl-3-(3-dimethylaminopropyl)) carbodiimide
EDTA	ethylene diamine tetra acetic acid
ELISA	enzyme-linked immunosorbent assay
EMIT	enzyme-multiplied immunoassay technique
EPPS	N-(2-hydroxyethyl)-piperazine-N'-(3-propane sulfonic acid)

EQAS	External Quality Assessment Scheme
F	free, force
F ₁	first generation
FCA	Freunds complete adjuvant
FCS	foetal calf serum
FIA	Freunds incomplete adjuvant
γ	gamma
g	gram, gauge, gravity
G6PD	glucose 6 phosphate dehydrogenase
GH	growth hormone
GHRH	growth hormone releasing hormone
GMP	guanosine monophosphate
GTT	glucose tolerance test
h	hour
HAT	hypoxanthine, aminopterin, thymidine
HCM	hypercalcaemia of malignancy
HEPES	N-(2-hydroxyethyl)-piperazine-N'-(2-ethanesulfonic acid)
HGPRT	hypoxanthine-guanine phosphoribosyl transferase
HPLC	high performance liquid chromatography
HSS	N-hydroxysulphosuccinimide
Ia	I-region associated antigen
IGF	insulin like growth factor
IgG	immunoglobulin G
Ir	immune response (gene)
IRMA	immunoradiometric assay
IRP	International Reference Preparation
ITT	insulin tolerance test
iv	intravenous
K	equilibrium constant, Kiilo

κ	kappa
ka	association constant
kd	dissociation constant
KLH	keyhole limpet haemocyanin
λ	lambda
l	litre
M	mega, $\times 10^6$, molar
m	metre, milli, $\times 10^{-3}$
μ	micro, $\times 10^{-6}$
MHC	major histocompatibility complex
min	minute
mol	mole
MOPC	mineral oil induced plasmacytoma
MRC	Medical Research Council
n	nano, $\times 10^{-9}$
NIBSC	National Institute of Biological Standards and Control
$^{\circ}\text{C}$	degrees Celsius
ODS	octadecyl silane
p	pico, $\times 10^{-12}$
PEG	polyethylene glycol
psi	pounds per square inch
PTH	parathyroid hormone
RIA	radioimmunoassay
RNA	ribonucleic acid
RPMI	Rothwell Park Memorial Institute
s	second
SAM	sheep anti-mouse
SAPU	Scottish Antibody Production Unit
SD	standard deviation

SP	solid phase
TAPS	([2-hydroxy-1,1-bis(hydroxymethyl)-ethyl]-1-propanesulphonic acid
TFA	trifluoroacetic acid
T _H	helper T lymphocyte
TK	thymidine kinase
T _S	suppressor T lymphocyte
U	units
v/v	volume/volume
w/v	weight/volume
WHO	World Health Organisation

PUBLICATIONS

Chapman, R.S., **Perry, B.**, Biggart, E.M., Stevenson, J.D. & Logue, F.C. (1985). Monoclonal antibodies for immunometric assays of the future. Meeting of the Caledonian Society for Endocrinology. Abstract.

Dorrian, C.A., Chapman, R.S., Logue, F.C., **Perry, B.**, Beastall, G.H. & Munro, A.C. (1985). Monoclonal antibodies to insulin : production and characterisation. West of Scotland Immunology and Scottish Immunology Group. Abstract

Biggart, E.M., Logue, F.C., **Perry, B.** & Chapman, R.S. (1986). Application of monoclonal antibodies to the measurement of TSH in dried blood as a screening method for neonatal hypothyroidism. Journal of Endocrinology, 111 supp., 62.

Logue, F.C., **Perry, B.**, Chapman, R.S. & Biggart, E.M. (1986). Monoclonal antibodies to human parathyroid hormone (1-34). Journal of Endocrinology, 111 supp., 70.

Stevenson, J.D., Chapman, R.S., **Perry, B.** & Logue, F.C. (1987). Evaluation and clinical application of a two-site immunoradiometric assay for alpha -1-foetoprotein using readily available reagents. Annals of Clinical Biochemistry, 24, 411-418.

Perry, B., Chapman, R.S., Logue, F.C. & Beastall, G.H. (1987). Observations on the radioiodination of human α -atrial natriuretic peptide. Journal of Endocrinology, 112 supp., 251.

Logue, F.C., **Perry, B.**, Chapman, R.S., James, K. & Beastall, G.H. (1988). The development of a two-site immunometric (IRMA) for intact 1-84 human parathyroid hormone using monoclonal antibodies. Journal of Endocrinology, 117 supp., 67.

Fraser, W.D., Logue, F.C., Griffin, D., **Perry, B.**, Cameron, D. Kelly, A.J., Christie, J., O'Reilly, D. StJ., & Beastall, G.H. (1990). Cross-correlation analysis of the relationship between the circadian rhythms of PTH (1-84) and hormones of the anterior pituitary. Proceedings of the Association of Clinical Biochemists, Brighton. Abstract C44.

Perry, B., Chapman, R.S., McConway, M.G., Griffin, D. & Beastall, G.H. (1991). Specificity of two-site immunometric assays. Annals of Clinical Biochemistry, **28**, 83–86.

Logue, F.C., **Perry, B.**, Biggart, E.M., Chapman, R.S. & Beastall, G.H. (1991). Production and characterisation of monoclonal antibodies to parathyroid hormone (1–34). Journal of Immunological Methods, **137**, 159–166.

Logue, F.C., **Perry, B.**, Chapman, R.S., Milne, I., James, K. & Beastall, G.H. (1991). A two-site immunoradiometric assay for PTH(1–84) using N and C terminal specific monoclonal antibodies. Annals of Clinical Biochemistry, **28**, 160–166.

McConway, M.G., Chapman, R.S., **Perry, B.** & Beastall, G.H. (1991). Second IRP [80/558] hTSH standard composition influences specificity assessment of an hFSH immunometric assay. Annals of Clinical Biochemistry, **28**, 526–527.

LIST OF TABLES

Table		Following page
3.1	Factors influencing normal growth hormone secretion.	72
3.2	Clinical tests of growth hormone reserve.	74
3.3	A typical clone plate showing percentage binding for individual wells.	78
3.4	Recovery of added growth hormone from three serum pools as a function of standard matrix.	82
3.5	Recovery of added growth hormone from three pools – GTT suppressed serum matrix and immunoextracted serum matrix.	83
3.6	Comparison of growth hormone concentrations in EQAS pools : RIA versus IRMA.	84
3.7	Recovery of exogenous growth hormone from serum in the presence of elevated prolactin concentrations.	86
3.8	Recovery of exogenous growth hormone from serum in the presence of elevated HPL concentrations.	86
4.1	Summary of responses to immunisation with various PTH fragments.	100
4.2	Isotypes of anti-PTH 1–34 monoclonal antibodies.	101
4.3	% Inhibition of I ¹²⁵ 1–34 PTH by equimolar concentrations of PTH and PTH fragments.	102
4.4	Results of tests for complimentary anti-PTH monoclonal antibodies.	104
4.5	Inter assay precision : performance of PTH IRMA over a three month period.	106

Table		Following page
5.1	Methodological variations used for the extraction of ANF from plasma.	113
5.2	Methodological variations used for the preparation of radiolabelled ANF.	114
5.3	Immunoactivity of the radiolabelled peptides isolated by HPLC from four iodination procedures.	122
6.1	Coupling of anti-ANF monoclonal antibodies to Sepharose CL4B.	131
6.2	Evaluation of ANF antibody complementarity.	133
6.3	Coupling of anti-ANF to magnetic particles.	135
6.4	Recovery of exogenous ANF from plasma.	137

LIST OF FIGURES

Figure		Following page
1.1	Model of an immunoglobulin molecule.	31
1.2	Procedure for the production of monoclonal antibodies.	38
1.3	Principle of saturation analysis and a typical dose response curve.	44
1.4	Principle of immunometric analysis and a typical dose response curve.	45
1.5	The principle of the Dako amplified enzyme immunoassay.	47
1.6	Principle of time-resolved fluorescence.	47
1.7	A schematic diagram showing the products obtained on oxidation of luminol.	48
1.8	The chemiluminescent reaction of the acridinium ester p-carboxyphenyl-N, 10-methyl 9-carboxylate bromide.	48
3.1	Primary structure of growth hormone.	71
3.2a	The growth hormone/chorionic somatomammotrophin gene family.	71
3.2b	Schematic representation of the biosynthesis of growth hormone.	71
3.3	Physiological effects of growth hormone	73
3.4	Antibody titres of balb/c mice immunised with growth hormone.	77

Figure		Following page
3.5	Production of monoclonal antibodies for growth hormone : results of primary screening assay.	78
3.6	Production of monoclonal antibodies for growth hormone : results of displacement studies.	78
3.7	Lactoperoxidase radioiodination of GH3/H10 monoclonal antibody.	79
3.8	Initial dose response curve for growth hormone IRMA.	80
3.9	Effect of standard matrix on dose response curve for growth hormone IRMA.	82
3.10	Percentage I ¹²⁵ growth hormone immunoextracted from human serum.	82
3.11	Dose response curves for growth hormone IRMA using glucose suppressed serum, from four normal volunteers, as standard matrix.	83
3.12	Within assay precision profile of optimised growth hormone IRMA.	84
3.13	Inter-assay precision profile for optimised growth hormone IRMA.	85
3.14	External quality assessment of optimised growth hormone IRMA.	85
3.15	Cross-reactivity of placental lactogen and prolactin in optimised growth hormone IRMA.	86
3.16	Clinical validation of optimised growth hormone IRMA : glucose tolerance tests.	87

Figure		Following page
3.17	Clinical validation of optimised growth hormone IRMA : exercise tests.	88
3.18	Clinical validation of optimised growth hormone IRMA : insulin tolerance tests.	88
3.19	Clinical validation of optimised growth hormone IRMA : clonidine stimulation tests.	89
4.1	The primary structure of pre–parathyroid hormone.	92
4.2	Synthesis and secretion of parathyroid hormone in the parathyroid cell.	93
4.3	Antibody titres of sequential ascitic fluid taps.	102
4.4	Radioiodination profiles of two C–terminal specific anti– PTH monoclonal antibodies.	103
4.5	Dose response curve and within assay precision profile of optimised PTH IRMA.	106
4.6	PTH concentrations in defined clinical groups.	107
5.1	Primary structure of pre–proatrial natriuretic factor.	110
5.2	Summary of the nomenclature of human and rat atrial peptides.	110
5.3	Gel filtration purification of radiolabelled ANF.	118
5.4	Rabbit anti–ANF dilution curve.	119

Figure		Following page
5.5	Preliminary purification of radiolabelled ANF by HPLC.	119
5.6	Examination of ANF purity by HPLC.	119
5.7	Radioactivity profile of ANF post lactoperoxidase iodination and HPLC purification.	120
5.8	Optical profile of ANF post lactoperoxidase iodination and HPLC purification.	120
5.9	Comparison of radio and optical HPLC profiles for ANF 99–126 and Met[O]110 ANF 99–126 before and after iodination. A commercial mono-iodo ANF 99–126 is shown for reference.	121
5.10	Comparison of the HPLC radioiodination profiles for ANF 99–126 by four methods, lactoperoxidase, chloramine T, iodogen and N-bromosuccinimide.	122
5.11	Comparison of the HPLC radioiodination profiles for ANF 99–126 by chloramine T at three molar concentrations.	122
5.12	Antibody dilution curves for NZB/balb/c F1 hybrid mice immunised with ANF fragments conjugated to KLH.	123
5.13	Antibody dilution curves for a further five NZB/balb/c F1 hybrid mice immunised with ANF 121–126 KLH conjugate.	123
5.14	Comparison of solid phase sheep anti-mouse and PEG/ γ -globulin separation systems in normal mouse serum and hyper immune mouse serum.	125

Figure		Following page
5.15	Antibody dilution curves for an individual mouse immunised with ANF 121–126 KLH conjugate : comparison of two separation systems.	126
6.1	Assessment of ANF antibody titres.	130
6.2	Assessment of relative affinities of ANF antibodies.	130
6.3	Affinity purification of anti–ANF 3H5.	131
6.4	Iodination profiles of ANF antibodies.	131
6.5	ANF radioimmunoassay : dose response curve.	134
6.6	The effect of delayed addition of ^{125}I ANF on assay sensitivity.	134
6.7	The effect of radiolabelled ANF mass on assay sensitivity.	134
6.8	Assessment of specific antibody coupling to magnetic particles.	136
6.9	Assessment of steric hinderence effect relative to coupling efficiency of anti–ANF to magnetic particles.	136
6.10	ANF radioimmunoassay dose response curve for magnetic particle assay.	136
6.11	Evaluation of ANF standard potency following six months storage at $-20\text{ }^{\circ}\text{C}$.	138
6.12	Scatchard plots assessing the avidity constants of Anti–ANF (ESA4) of ^{125}I ANF 99–126 and ^{125}I Met[O]ANF 99–126.	138

Figure		Following page
6.13	Comparison of Met[O]ANF 99-126 and ANF 99-126 standards.	139
6.14	Evaluation of the effects of acetonitrile concentration on the elution of ANF from Sep-Pak ODS cartridges.	140

ACKNOWLEDGEMENTS

I wish to thank Dr. Graham Beastall for his untiring supervision of this project, for the opportunity to participate in the development of the endocrinology unit of the Institute of Biochemistry and for his generous enthusiasm in supporting my personal ambitions. Graham's contribution could never be overstated. I am also grateful to Professors H.G. Morgan and J. Shepherd for their general support and the use of the facilities in their department.

I am particularly appreciative of my invaluable association with Dr. Richard Chapman and Dr. Fraser Logue. The cross fertilisation of ideas and endless hours of debate provided a deeper understanding of the principles of antibody production, immunoassay design and aided the resolution of theoretical and practical problems. My thanks are also due to Richard for his contribution to proof reading this manuscript and his patience in teaching me animal handling techniques. I am also indebted to Fraser for allowing me to collaborate on his parathyroid hormone project and for the use of some of his clinical data.

I thank Dr. Elizabeth Biggart, Mr David Stevenson for their skilled assistance with cell work and screening assays and Mrs I. Cameron for her help in the tissue culture laboratory. I also thank Dr. Christina Gray for the proof reading she did of some of my initial attempts at putting this work on paper.

I am obliged to Dr. C. Prowse of the Edinburgh and South-East Scotland Blood Transfusion Service, Royal Infirmary, Edinburgh; Mr A. Thakur, Middlesex Hospital, London and the Blood Pressure Unit of the Western Infirmary for supplying a variety of antibodies used in this project.

A number of the staff of the Institute of Biochemistry gave freely of their blood in both large and small amounts and I am grateful to them all for this service. Thanks are also due specifically to all the staff of the endocrinology unit for providing an invigorating, supportive environment in which to work.

Last and by no means least I wish to express my most sincere thanks to my wife Yvonne for her unfailing support and encouragement without which this thesis would never have been completed. There has been a great sacrifice on her part and that of my children Elaine and Michael for which I will be eternally grateful. Recompense is now due.

SUMMARY

The work of Kohler and Milstein (1975) on the production of immortal cell lines secreting antibody in conjunction with that of Miles and Hales (1968) on the concept of the immunometric assay and later Woodhead et al (1974) with the two-site immunometric assay has caused a revolution in the exploitation of antibodies as diagnostic reagents. The properties of monoclonal antibodies are particularly suited to application in immunometric assays and overcome all the major problems associated with the use of conventional antisera. The work in this thesis is concerned with the production of monoclonal antibodies with suitable characteristics and their application to immunoassays for protein and peptide hormones.

A structural and clinical perspective on growth hormone introduces chapter three, followed by a review of methods utilised in the measurement of its concentration. The major part of the chapter deals with the production of monoclonal antibodies to human growth hormone and the development of a two-site immunoradiometric assay. Over one thousand antibody secreting hybrids were identified. Relative affinity estimates were used to select the most suitable for use in assay development. The final assay is precise, sensitive, offers a wide working range and can be completed within the day. Assay specificity was defined by recovery estimates of exogenous growth hormone in the presence of elevated endogenous concentrations of prolactin and placental lactogen. The clinical utility of the assay is demonstrated with reference to dynamic function tests in comparison with a well established radioimmunoassay. The long term stability of the assay is proven with UK EQAS data during the first year of routine application.

Chapter four relates to parathyroid hormone. Structural and physiological considerations determine the strategy adopted in attempts to produce monoclonal antibodies. The five isolated monoclonal antibodies were evaluated on the basis of specificity and relative affinity for 1-84 human PTH. A sensitive and precise two-site

immunoradiometric assay for intact 1–84 PTH was developed and validated. Clinical studies with this assay show good discrimination between normal subjects and patients with primary hyperparathyroidism.

Chapter five describes attempts to produce monoclonal antibodies to the recently discovered atrial natriuretic peptide, ANF 99–126. Initial hybridisation experiments were disappointing despite the presence of antibodies in the serum of donor mice. The screening procedure was extensively investigated and the radioiodination procedure discovered to be of key importance. A post-iodination purification method utilising HPLC was developed which allows the isolation of mono-iodo ANF 99–126 from the di-iodinated and methionine sulphoxide derivatives. The efficiency of the sheep anti-mouse solid-phase separation used in the screening assay was also evaluated.

Chapter six describes attempts to find a combination of available anti-ANF antibodies suitable for use in a two-site assay. The four monoclonal antibodies and one polyclonal antiserum examined failed to provide a complementary pair. The best of these antibodies in terms of avidity, a monoclonal antibody, was utilised in the development of a solid-phase radioimmunoassay based initially on Sepharose particles and subsequently on magnetic particles. Direct measurement of ANF in plasma was not possible, therefore a plasma extraction method was developed. Comparison of results with published data suggested that the assay may have a positive bias. Studies on the oxidation state of standard materials and the relative antibody affinity for oxidised standard and radiolabel in contrast to affinity for non-oxidised ANF are detailed. Examination of the elution of ANF from ODS cartridges revealed the presence of an unidentified cross reactant.

Chapter seven summarises the general findings from this project, highlights problem areas and offers some suggestions for the future. In broad terms the project was successful, its major aims having been achieved.

CHAPTER 1

GENERAL INTRODUCTION

The development of clinically useful immunoassays requires a knowledge of the immune system, particularly the theory of antibody production, the structure and properties of antibodies, immunoassay design and the physiology and pathophysiology relating to the substances of interest.

1.1.2 The Immune System

The vertebrate immune system is capable of mediating immunity in both a non-specific and a specific manner. Non-specific immunity is effected by physical and chemical barriers as well as cellular components of the reticuloendothelial system. While this type of immunity is not enhanced by repeated exposure to antigen it does play a role in the development of acquired immunity (Unanue, 1972). Specific acquired immunity is enhanced by repeated exposure to antigen and is mediated by lymphocytes. These lymphoid system cells can be divided into two groups dependant upon the lymphoid organ of origin (Mitchell & Miller, 1968). B cells originate from the foetal liver and bone marrow while T cells originate from the thymus. It is in this environment that the lymphocytes learn to discriminate self from non-self and acquire their repertoire of specific antigen receptors and therefore become committed to a single antigenic specificity for their life span (Burnet, 1959). Mature T and B lymphocytes migrate to the secondary lymphoid organs, the spleen and lymph nodes, where they interact with macrophages and each other to mount an immune response.

1.1.3 The Humoral Immune Response

A humoral response is one that results in the production of antibodies by B lymphocytes. The activity of the B lymphocytes is regulated directly or indirectly by two sub sets of T lymphocytes known as T-helper (T_H) and T-suppressor (T_S)

cells (Jandinski *et al*, 1976; Cantor *et al*, 1976).

The initial stages of an antibody response involve the transport of antigen from the periphery to lymph nodes and their non-specific engulfment by macrophages. Once internalised the antigen is partially degraded and fragments of it appear on the cell surface complexed with I region associated (Ia) antigens which are coded for by the I region of the major histocompatibility complex (MHC). These antigen fragment-Ia antigen complexes interact with T_H cell receptors, which are specific for both components of the complex, resulting in proliferation by clonal expansion of the selected T_H cells. These T_H cells are now primed and will only interact with B lymphocytes which present antigen and Ia antigen in the orientation as originally seen on the macrophage. This phenomenon is known as MHC restriction and appears to be antigen-specific.

B lymphocytes also bind to antigen, but unlike the interaction with macrophages this process is specific being mediated by cell surface immunoglobulin. Internalisation, degradation and complexing with Ia antigens follows resulting in cell surface presentation of antigen fragment-Ia antigen complex identical to the analogous complexes on the macrophages involved in the priming of T_H cells. Interaction between T_H and B lymphocytes provides the stimulus that leads to the differentiation of B cells into either plasma cells, which are short lived and devoted to the production of antibody, or memory cells, which are long lived and do not secrete antibody.

When an antigen is encountered by the immune system for the first time the response observed is weak relative to that seen on subsequent exposure. This is because only a small number of lymphocytes will be able to bind to the antigen. Exposure to antigen results in clonal proliferation as described above thus on subsequent exposure the response is more vigorous.

1.1.4 Genetic Control of the Murine Immune Response

Autosomal dominant genes controlling the immune response to various antigens have been reported (Benacerraf & McDevitt, 1972). These immune response (Ir) genes have been mapped to the I region of the major histocompatibility complex (H-2 in the mouse) (Katz *et al*, 1975). The Ia antigens are the products of these genes and are expressed predominantly on B lymphocytes and macrophages where they effect the antigen-specific MHC restriction of T cells (Schwartz, 1986 ; Unane *et al*, 1974). A number of theories have been proposed to account for the antigen-specific effects of the Ia antigens on the immune response but it is still unclear which is correct (Katz *et al*, 1975).

1.1.5 Immunogenicity

The immunogenicity of a molecule relates to its ability to induce an immune response ie. produce antibodies. Antigenicity in contrast relates only to the ability to combine with antibody.

Generally the greater the phylogenetic distance between the immunogen and the recipient the more vigorous the response. Highly conserved proteins tend to illicit weak responses because structural differences from the host's self-proteins are limited (Lanzavecchia, 1986).

To be immunogenic a molecule must possess two distinct epitopes (Lanzavecchia, 1986). These are required since the molecule must combine with surface antibody on B cells and also after degradation inside the B cell or macrophage, bind simultaneously to the Ia antigens on the B cell/macrophage surface and the T cell receptor (Goodman, 1983). The former epitope determines the specificity of the antibodies produced and is an absolute requirement in eliciting an antibody response.

The requirements for immunogenicity can be divided into two categories, those which are intrinsic to the molecule and those which are extrinsic (Berzofsky,

1985). Intrinsic properties relate to the epitope which binds to the B cell and include accessibility (ie tertiary structure) and hydrophilicity. Extrinsic properties relate to the Ia antigen–T cell receptor binding site, recognition of which is restricted by a number of variables all of which are a function of the host and therefore change depending on the species or individual chosen for immunisation.

From the above it can be seen that molecules fail to be immunogenic for one of two reasons. Firstly they may be too small to possess an Ia antigen–T cell receptor binding site in addition to an epitope recognised by B lymphocytes and as such are classified as haptens. Alternatively they share a high degree of sequence homology with a recipient molecule and as such are not recognised as foreign due to MHC restriction of the immune response. Both of these problems can be overcome by conjugating the molecule to an immunogenic carrier molecule. This provides the Ia antigen–T cell receptor binding site in the case of haptens and an alternative binding site in the case of MHC restriction. In the latter case the immunisation of a number of inbred strains of animal may be an additional or alternative solution.

1.1.6 The Structure of Immunoglobulins

All antibodies are immunoglobulins. Immunoglobulins are made up of two identical heavy and two identical light chains held together by inter-chain disulphide bonds (Figure 1.1). Valentine and Green (1967) elegantly demonstrated the structure of immunoglobulins to be Y shaped hinged molecules with the antigen combining site at the end of each of the two arms. Sequencing studies on a number of myeloma proteins have revealed that the N-terminal portions of both heavy and light chains show considerable variability whereas the remaining parts of the chains are relatively constant. The site of antigen binding is believed to be the N-terminal variable regions.

Based upon the structure of their heavy chain constant regions,

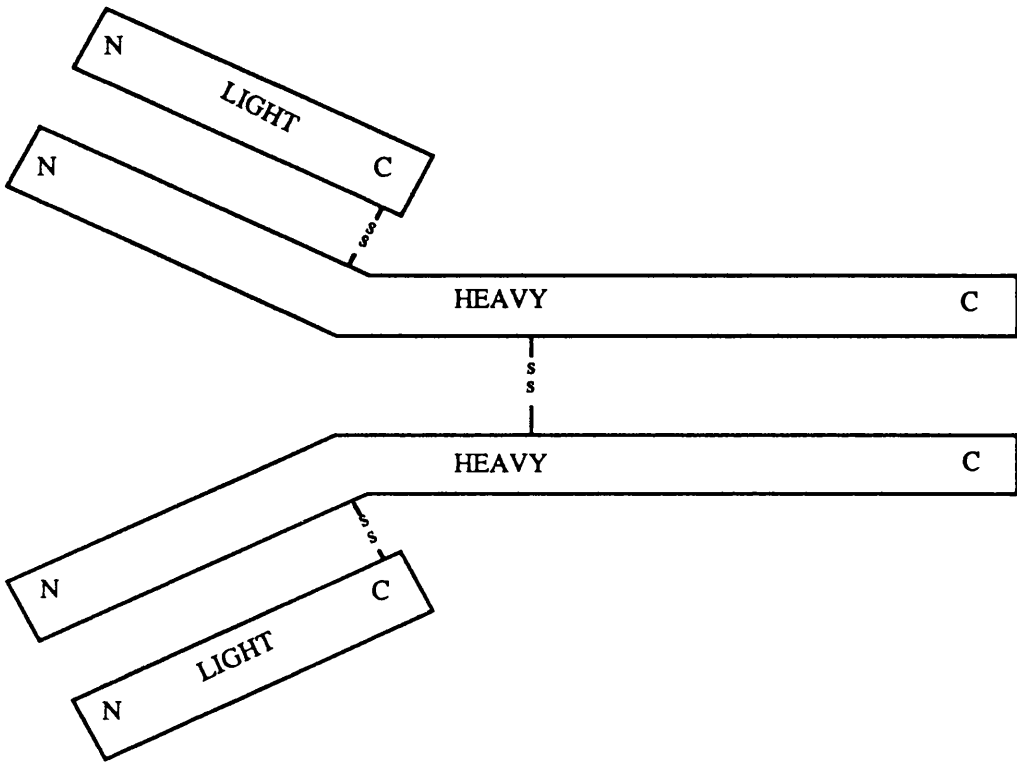

Figure 1.1 Model of an immunoglobulin molecule

immunoglobulins, are divided in classes and may be further divided into subclasses. The major classes/subclasses in the mouse, for example, are IgG1, IgG2a, IgG2b, IgA and IgM. Light chain constant regions also exist in two isotopic forms known as κ and λ . Both light chains in a given immunoglobulin molecule are identical.

1.1.7 Antibody Antigen Interaction

Antibodies and antigens interact by spatial complementarity not by covalent bonding. The forces binding antigen to antibody become large as intermolecular distances become small. These intermolecular forces may be classified under four headings.

1) Electrostatic

These are due to the attraction between oppositely charged ionic groups on the two protein side-chains. The force of attraction (F) is inversely proportional to the square of the distance (d) between the charges :-

$$F \propto 1/k_D d^2$$

where k_D is the dielectric constant. Since the dielectric constant of water is extremely high, exclusion of water molecules through the contiguity of the interacting molecules would greatly increase the value of F .

2) Hydrogen Bonding

Hydrogen bonding is the formation of hydrogen bridges between hydrophilic groups such as $-\text{OH}$, $-\text{NH}_2$ and $-\text{COOH}$ and depends upon the close approach of the two molecules carrying these groups. Hydrogen bonds are essentially electrostatic in nature and exclusion of water enhances binding energy.

3) Hydrophobic

The side chains of amino acids such as valine, leucine and phenylalanine are hydrophobic and in aqueous solution the water molecules with which they come into contact are not hydrogen bonded and are therefore in a higher energy state than

they would be if free to form more hydrogen bonds with themselves or some other hydrophilic molecule. If hydrophobic molecules on the surfaces of two proteins come into close contact so as to exclude water molecules between them, the net surface in contact with water is reduced. Thus more water molecules are in the hydrogen bonded state than were when the two proteins were apart. This means that the proteins take up a lower energy state and hence a preferred configuration when they are combined rather than separated. There is therefore a force of attraction between them.

4) Van der Waals

These are forces between molecules which depend upon interaction between external 'electron clouds'. The nature of this interaction can be likened to a temporary perturbation of electrons in one molecule effectively forming a dipole which induces a dipole in the other molecule, the two dipoles having a force of attraction between them. As the electrons swing back through the equilibrium position and beyond the dipoles oscillate. The force of attraction is inversely proportional to the seventh power of the distance ie. :-

$$F \propto 1/d^7$$

and as a result this rises as the interacting molecules come closer together.

Common to all four types of force is their dependence upon the close approach of both molecules before the force becomes of significant magnitude and this force increases if water is excluded.

1.2.1 Introduction

There are no generally accepted guidelines for the production of antisera. The literature contains reports of a multitude of strategies many of which are prejudice or anecdote. However, a number of key factors can be identified as having relevance to the outcome.

1.2.2 The Immunogen

Generally proteins having a molecular weight in excess of 5000 readily stimulate the production of avid antibodies. Some proteins (such as insulin) may form dimers or larger aggregates in solution and this probably increases their immunogenicity. Peptides of low molecular weight are generally less immunogenic although a number of workers have successfully raised antisera to unmodified octa, nona and deca peptides. Molecules which are not in themselves immunogenic will require conjugation to a larger immunogenic molecule such as albumin or keyhole limpet haemocyanin (KLH). The specificity of antisera produced from conjugates may be effected by the haptens orientation after coupling. Many methods of coupling are described in the literature offering some choice of attachment point.

1.2.3 Choice of Adjuvant

The most commonly used adjuvant is Freund's which comes in two forms, complete and incomplete. Freund's complete adjuvant (FCA) contains *Mycobacterium tuberculosis* of which the active component is muramyl dipeptide (Ellouz *et al*, 1974). There are two components to the mechanism of action of adjuvants. Firstly they form a depot which protects the antigen from catabolism and slowly releases it over an extended period of time and secondly they stimulate the immune response in a non-specific manner. In the case of complete adjuvant this

involves local formation of granulomas which are rich in macrophages and immunocompetent cells (Warren *et al*, 1986). Normally FCA is used for primary immunisation while incomplete adjuvant (FIA) is used for subsequent booster injections.

1.2.4 Choice of Animal Species and Strain

This choice will be dependent upon the immunogen and differences in structure/sequence relative to those of the proposed host. The volume of antiserum required may be a factor as may be any particular animal handling/housing requirements.

Most polyclonal antisera for immunoassay purposes have been produced in rabbits, guinea-pigs, sheep or donkeys. Occasionally the choice of species is particularly restricted eg the use of guinea-pigs for the production of antisera to insulin.

1.2.5 Route of Immunisation

Commonly used routes are intramuscular, subcutaneous, intradermal and intraperitoneal. It is generally accepted practice to use several sites except in the case of the intraperitoneal route where only one site is preferred. Some workers have used intranodal injections with success but since this requires surgery and the success rates have not been shown to be significantly better than standard routes the technique has not been widely used.

1.2.6 Quantity of Immunogen

Doses have been recommended which range from as little as 1– 50 µg for mice (Campbell, 1984) up to several mg for larger animals (Hurn & Landon, 1971). The general rule for the achievement of maximum avidity is to reduce the amount of immunogen to the minimum effective level. In some cases availability/cost of

immunogen will be an overriding factor.

1.3 MONOCLONAL ANTIBODY PRODUCTION

1.3.1. Introduction

Immunological methods suffer from several limitations which significantly restrict their applicability and usefulness. Firstly, there are often substantial practical difficulties in purification of antigens from human sources, for use in immunisation, standardisation and the isolation of specific antibodies. Secondly, the generation and continued production of antibody with appropriate specificity and other properties is not always easy. All conventional antisera contain complex mixtures of different antibodies of varying specificity and avidity, recognising various aspects of antigenic structure. Further, individual sera from different animals, or even at different times in a given animal, differ in the mixture of antibodies they contain and so do not necessarily have the same properties. The heterogeneity of the immune response *in vivo* results from the fact that antigen indirectly stimulates the clonal proliferation of many different antibody-producing cells (McConnell *et al*, 1981), each one secreting a single antibody species. The complex (polyclonal) mixture of antibodies which results is extremely difficult to resolve into its individual components, and only relatively crude fractionation on the basis of gross differences in specificity, or avidity is generally possible.

The development of techniques for the production of monoclonal antibodies (Kohler & Milstein, 1975) enormously expanded the potential for the application of antibodies as analytical and preparative reagents. Monoclonal antibodies are the products of individual cloned cell lines which may be grown *in vitro*, and as such they are homogeneous preparations with defined specificity and affinity.

Lymphocytes from immunised animals will not themselves grow *in vitro* but by fusion with myeloma cell lines they may be immortalised. The hybrid cells

(hybridoma) which result retain the important properties of both parent cell types. They continue to produce antibody characteristic of the lymphocyte and also grow indefinitely in culture as myeloma cells.

1.3.2 Rationale of Cell Fusion

Almost any two cell types can be made to fuse by the addition of Sendai virus, lysolecithin or polyethylene glycol (PEG). PEG is now the agent of choice. The mechanism of fusion is poorly understood (Knutton & Pasternak, 1979; White & Helenius, 1980). The fusion of the plasma membranes results in the formation of heterokaryons which possess two or more nuclei. At the next division, the nuclei fuse, and a hybrid cell results.

Fusion is a relatively rare event, even when PEG is used. Thus, if tumour cells are fused with normal cells, the culture will be rapidly overgrown by unfused tumour cells. The most popular strategy for preventing this is that devised by Littlefield (1964).

The main biosynthetic pathway for purines and pyrimidines can be blocked by the folic acid antagonist aminopterin. However the cell can still synthesise DNA via the so called salvage pathways, in which preformed nucleotides are recycled. These pathways depend on the enzymes thymidine kinase (TK) and hypoxanthine guanine phosphoribosyl transferase (HGPRT). If one or other enzyme is absent DNA synthesis ceases. The cell can however be "rescued" by fusion with another cell which supplies the missing enzyme. Thus, if spleen cells (which possess TK and HGPRT but die in culture) are fused with cell lacking TK or HGPRT only hybrid cells will grow in a medium containing hypoxanthine, aminopterin and thymidine (HAT medium).

Mutant myeloma cells lacking HGPRT are produced by the use of thioguanine which is incorporated into DNA via HGPRT resulting in cell death. Only cells lacking this enzyme will survive thioguanine selection. Selection of

HGPRT deficient cells is relatively easy since the enzyme is coded for by a gene on the X chromosome. Mammalian cells possess only one active X chromosome and therefore only a single mutation is needed to result in total loss of the enzyme. TK deficient mutants are much more difficult to select since two simultaneous rare events are required.

In order to express a differentiated cell function the two parental cells should be at a similar stage of differentiation. The fusion of unlike cells frequently results in the extinction of differentiated function (Ringertz & Savage, 1976). Antibody secretion is only maintained if normal antibody-secreting cells are fused with myeloma cells. The choice of fusion partners is of key importance. Ideally this should be from the same species and of the same basic cell type. Figure 1.2 shows an outline of the basic procedure for monoclonal antibody production.

1.3.3 Choice of Cells for Fusion

The choice of myeloma cell line for culture and animal for immunisation are two interdependent variables. Stable antibody secreting hybrids are generally not produced from fusions between cells of different species due to preferential chromosome loss from one or other of the parent cells. The range of possibilities is therefore limited by the availability of myeloma cell lines. The myeloma cell lines of established value were all derived from Balb/c mice or Lou rats (Galfre and Milstein, 1981; Reading, 1982). Some myeloma cell lines secrete their own immunoglobulin and continue to secrete this in hybrid cells where the myeloma and lymphocyte heavy and light chains are randomly assembled. The resultant secreted antibodies will therefore contain only a small proportion of the original lymphocyte antibody. Myeloma cell line variants which secrete only light chains and in some cases no immunoglobulin at all have also been isolated (Kohler *et al*, 1976; Kearney *et al*, 1979). Such cell lines are to be preferred for monoclonal antibody production for immunoassay purposes reducing the need later for extensive

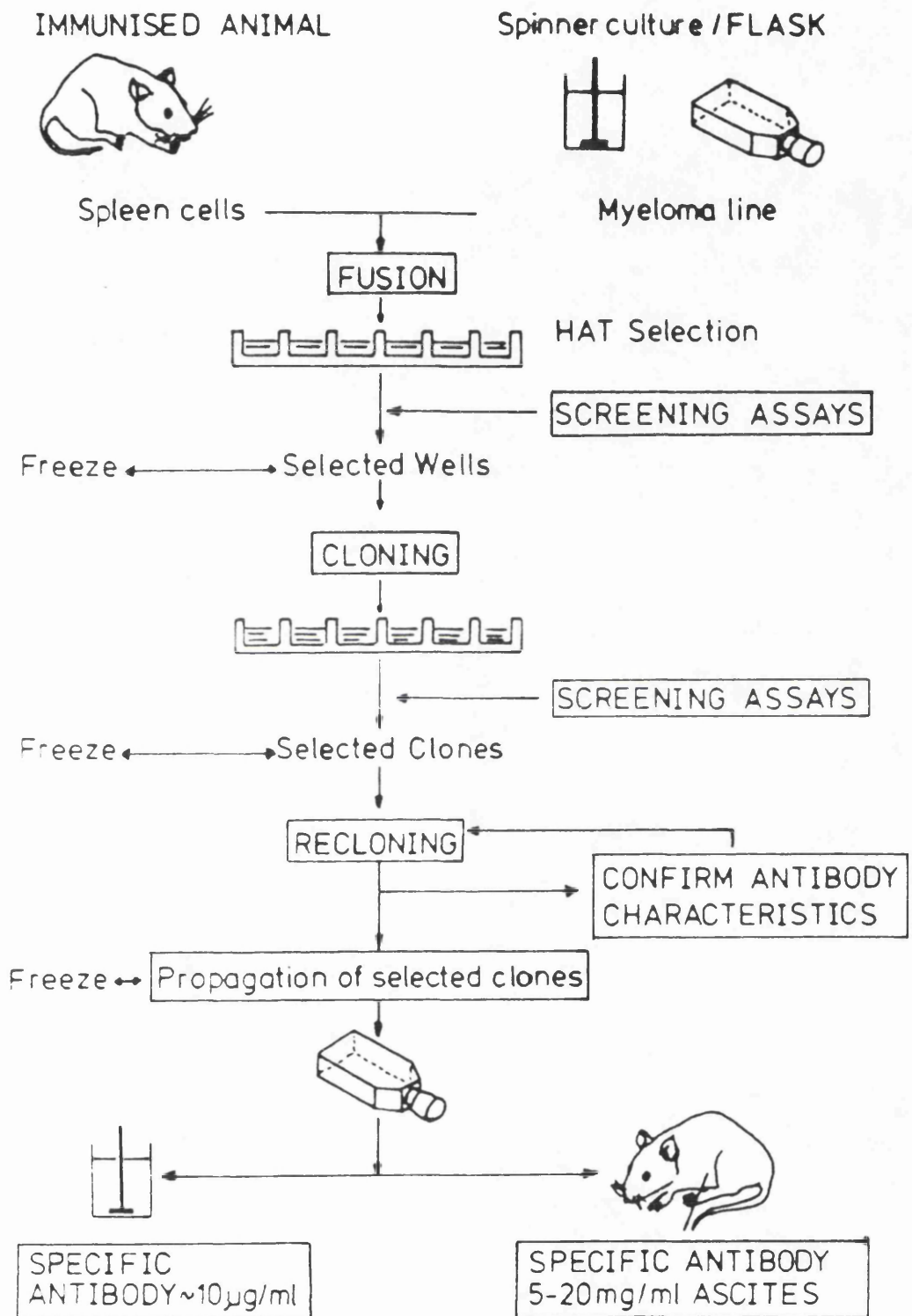

Figure 1.2 Procedure for the production of monoclonal antibodies.

purification.

Attempts at heterogeneous fusions between standard myeloma cell lines and lymphocytes of different species have been reported. Some success has been achieved from fusions between rat and mouse cells (Galfré *et al*, 1977) and stable hybrids between mouse myeloma and human lymphocytes have been described (Schlom *et al*, 1980; Valente *et al*, 1982).

The most important factor determining the choice of animal for immunisation is the relative responsiveness to a given antigen, and for the difficult antigens it may be necessary to attempt immunisations of several strains of both mice and rats (Goding, 1980). It is also an advantage to be able to use myeloma cells and lymphocytes from the same inbred strain to facilitate the subsequent growth of hybrid cells *in vivo* in this strain. Inter-strain hybrids can only be grown as tumours in the corresponding F1 hybrid animals. Inter-species hybrids are more problematical and *in vivo* growth needs to be in athymic (nude) mice or rats (Noeman *et al*, 1982).

It is usual to use the spleen as the source of lymphocytes for fusion when working with rats or mice, however, other cells e.g. lymph nodes may be used.

1.3.4 Immunisation

The potential yield of monoclonal antibodies is directly related to the immune response *in vivo* and the properties of the monoclonal antibodies will reflect those detected in the immunised animal. Immunisation strategy reported in monoclonal antibody production has the same mixture of serious study, anecdote and prejudice which has been described for conventional antiserum production. The initial immunisation is generally given subcutaneously or intraperitoneally using an emulsion of microgram quantities of antigen in Freund's complete adjuvant. One or more boosts emulsified in Freund's incomplete adjuvant may be given at intervals of a few weeks. The final boost is given intraperitoneally or intravenously in saline

three to four days prior to fusion. The timing of the final boost is thought to be critical (Oi *et al*, 1978).

To increase the chances of one good responder it is worth immunising as many animals including different strains as the available antigen permits. Immunogen purity is not particularly critical since screening of antibodies and cloning strategies isolate products of interest. However the way in which antigen is presented may influence the characteristics of monoclonal antibodies subsequently produced. Attention must be paid to the chemistry of conjugation to carrier proteins to avoid masking important structural groups.

1.3.5. Fusion Protocol

While the fusion event is central to the production of hybridomas it represents only a very small part of the total effort required. An important factor determining success at this stage is that both parental cells should be in the best possible condition. Myeloma cells should be in an exponential growth phase and lymphocytes appropriately stimulated. The two cell types are mixed, washed and centrifuged into a pellet. The fusogen is then slowly added and mixed with the cells. The fusion process is terminated by dilution of the fusogen/cell mixture.

Polyethylene glycol is almost universally used as the fusogen. Individual batches of polyethylene glycol vary considerably in their toxicity. Typical concentrations of PEG range from 30% to 50%. Below 30% fusion frequency is low and above 50% toxicity becomes acute. Precise cell numbers/ratios, temperature and PEG concentration do not appear to be critical as a number of different protocols have been described and applied successfully (Galfre *et al*, 1977; Geffer *et al*, 1977; Oi *et al*, 1978).

1.3.6 Hybrid Growth and Cloning

Fusion products are grown in medium containing HAT to selectively kill unfused myeloma cells. Unfused lymphocytes will not survive in culture for more than a few days.

Amongst the hybrid cells there will be a great variation in growth rates. Cells which grow fastest will rapidly dominate the culture numerically. Following fusion hybrids are unstable and prone to rapid loss of chromosomes. Since plasma cells may devote up to half their total protein synthesis to immunoglobulin a cell which sheds this burden is likely to grow faster. Thus there will be a strong tendency for cultures to be overgrown by non-secreting variants. To overcome this problem many workers have adopted the approach of distributing the products of fusion into a large number of small wells such that on average only one hybridoma clone grows in each (Oi & Herzenberg, 1980). Following the initial growth phase at least two cloning steps should be performed to ensure that a monoclonal cell line is obtained. There are two main cloning techniques, that of limiting dilution or cloning on soft agar. The former is more widely used.

Cloning by limiting dilution is based on the Poisson distribution $f(0)=e^{-\lambda}$ where $f(0)$ is the fraction of wells with no growth and λ is the average number of clones per well. If $\lambda=1$, then $f(0)=37\%$, ie, if at least 37% of wells show no growth then the probability is that those that do show growth contain true monoclonal hybridomas (Goding, 1980).

Hybrid cells in particular seem to be very intolerant of dilution. Early growth at low hybrid cell density is much improved by the presence of other cells as "feeders" (Coffino *et al*, 1972; Lernhardt *et al*, 1978). Most commonly peritoneal macrophages are used for this purpose though the use of thymocytes and normal spleen cells has been described (Hengartner *et al*, 1978; Oi & Herzenberg, 1980; Levy *et al*, 1978).

1.3.7 Expansion of Cloned Hybridomas

Cloned hybridomas can either be grown *in vitro* producing antibody in culture supernatant or *in vivo* producing antibody in ascitic fluid. Typically antibody concentrations that can be achieved in culture supernatants are 10–100 µg/ml. In contrast IgG levels in ascitic fluid are frequently 3–15 mg/ml.

The production of ascites may be favoured by intraperitoneally injecting recipient mice with mineral oils, usually 2,6,10,14–tetramethylpentadecane, one week prior to the injection of cells (Hoogenraad *et al*, 1983). The growth of tumours often results in ascitic fluid volumes of 5 ml or more. Sequential taps of fluid may be taken from individual animals.

1.3.8 Screening Assays

The assays used for both the evaluation of serum in the immunised animal and screening of the fusion products should be as similar as possible to the type of assay in which the monoclonal antibody will ultimately be used (Haaijman *et al*, 1984). Apart from this the chosen assay should be sensitive enough to detect the concentrations of antibody found in culture supernatants (<1 µg/ml). It should also be simple and rapid such that large numbers of samples can be handled at one time.

When fusions yield large numbers of positive hybrids it may be necessary to prioritise antibody characteristics requirements perhaps selecting on the basis of specificity rather than avidity.

When designing assay formats it should be remembered that coupling an antigen to solid-phase or labelling with an enzyme or radioisotope may alter, destroy or make inaccessible particular epitopes. This may lead to the preferential selection of antibodies with specificities other than those desired.

1.4.1 Introduction

The term "immunoassay" is used to describe the general technique wherein the substance of which the concentration in a biological fluid is to be measured (the analyte) is caused to react with a specific antibody directed against it, the analyte concentration being deduced by observation of the products of the binding reaction between them. The distinguishing feature is the use of an antibody as the essential "analytical reagent".

The particular usefulness of antibodies in this context principally derives from three characteristics 1) their high "structural specificity", i.e. their ability to recognise and bind to molecules of a particular molecular structure: 2) the relative ease with which antibodies of a defined structural specificity can be produced, originally by conventional immunisation procedures and more recently by *in vitro* hybridisation and selection techniques: 3) their generally high binding affinities which implies that they can be employed at low concentration to measure analytes likewise at low concentration.

These properties form the basis of the ubiquitous use of immunoassay procedures throughout biomedical science for the measurement of substances of biological importance.

It was in 1960 that two independent papers first described immunoassay techniques suitable for use in the clinical laboratory. While Yalow and Berson (1960) received the credit for the first description of the "radioimmunoassay" it was Ekins (1960) with his "saturation analysis" for thyroxine who first appreciated the wider potential of the technique.

The basic principle underlying immunoassay techniques is the Law of Mass Action.

This can be represented by the equation:–

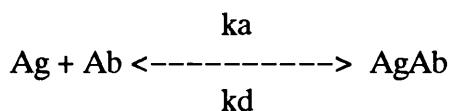

where k_a and k_d are the association and dissociation constants respectively. The equilibrium constant K can then be expressed as :-

$$K = \frac{k_a}{k_d} = \frac{[\text{AgAb}]}{[\text{Ag}][\text{Ab}]}$$

where $[\text{Ag}]$, $[\text{Ab}]$ and $[\text{AgAb}]$ represent the concentrations of free and complexed antigen and antibody in the final equilibrium mixture (Ekins, 1974).

1.4.2. Saturation Assays (Radioimmunoassay)

A fixed but limiting amount of antibody (Ab) is reacted with a fixed quantity of radioactively labelled antigen (Ag^*) and a variable amount of antigen (Ag) (standard or unknown sample). At equilibrium, the binding sites are saturated with Ag^* and Ag in proportion to their relative concentrations in the assay tube. The antibody bound and unbound (free) forms of antigen are separated and the amount of labelled Ag present in the bound fraction plotted as a function of the dose of antigen present. The concentration of Ag in an unknown sample may be read off a calibration (dose response) curve. This principle is illustrated in Figure 1.3. These assays are often referred to as "competitive" because of the competition between Ag and Ag^* for the limited number of available antibody binding sites.

The sensitivity of an RIA is governed by four factors (Ekins, 1981)

i) the equilibrium constant of the antigen-antibody interaction i.e. the avidity of the antiserum.

ii) the experimental error involved in the measurement of antibody-bound and free antigen.

iii) the specific activity of the labelled antigen.

iv) the misclassification of the bound and free antigen.

In practice (i) and (ii) impose the major constraints on assay sensitivity (Ekins,

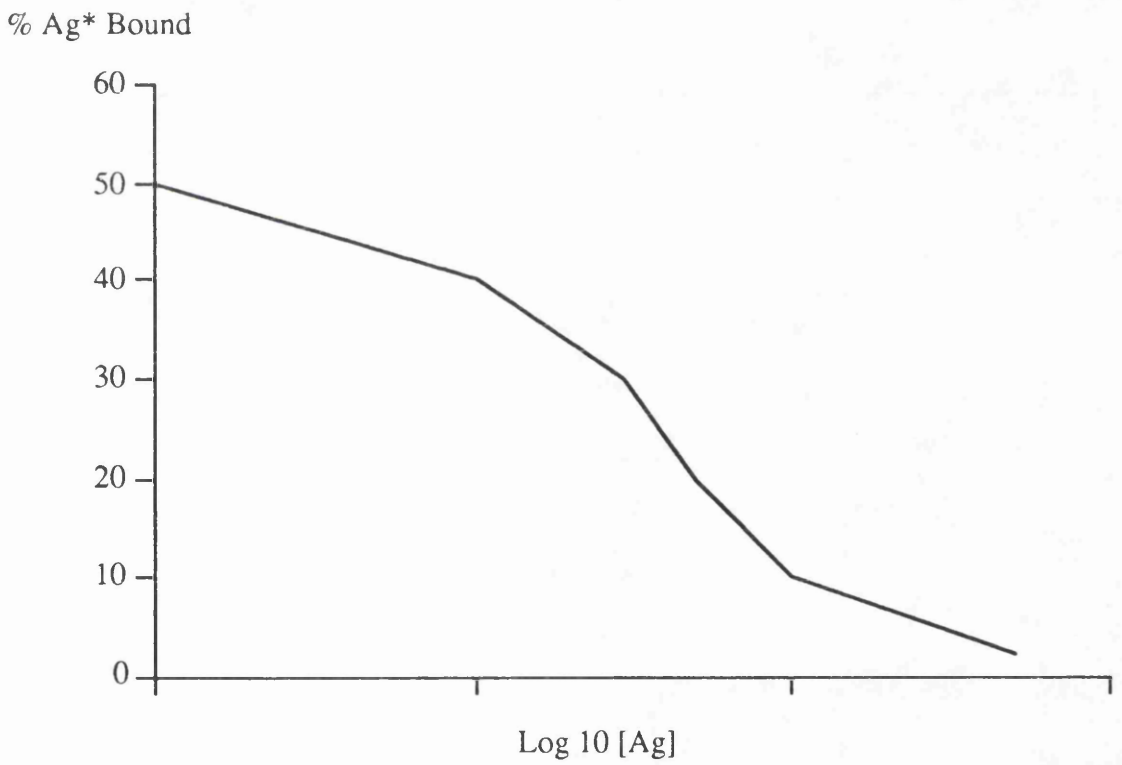
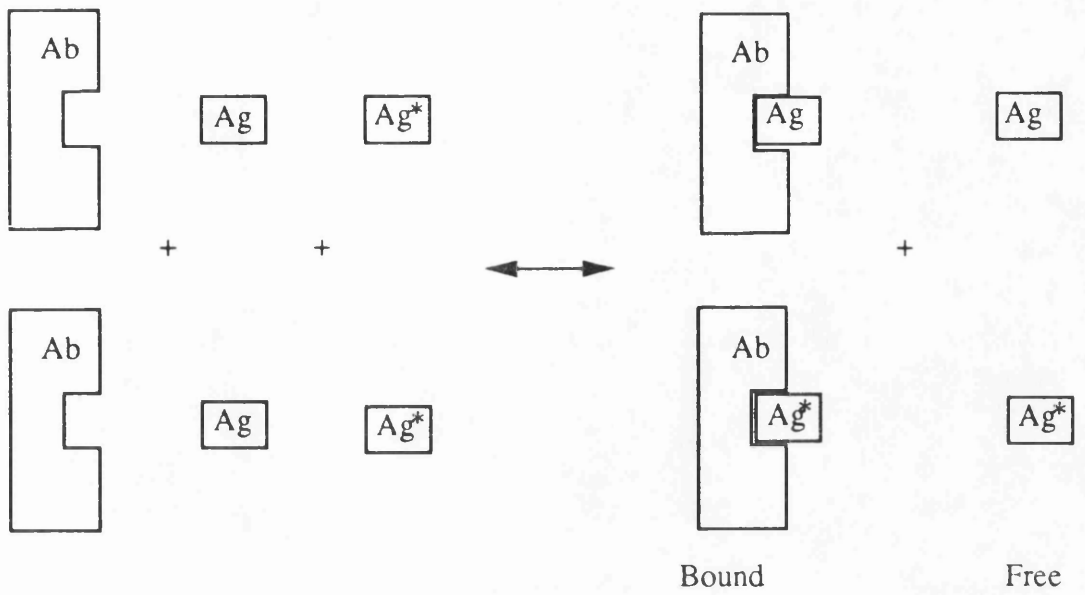

Figure 1.3 Principles of saturation analysis and a typical dose response curve

1981) while factor (iv) is a major cause of experimental imprecision and bias (Ratcliffe, 1983).

1.4.3. Immunometric Assay

The immunoradiometric assay (IRMA) was first described over twenty years ago (Miles & Hales, 1968^a). This assay technique differs from radioimmunoassay in that it employs a labelled antibody rather than antigen, and requires the use of excess rather than limiting amounts of antibody. In the original assays antigen was incubated with excess labelled antibody such that at equilibrium, with a high avidity antibody, most of the antigen but only a percentage of the labelled antibody, reacts to form the bound fraction. Free labelled antibody was separated by addition of solid-phase coupled antigen. The amount of antibody bound to antigen (not coupled to solid-phase) is directly proportional to the amount of antigen present. The most widely used form of immunometric assay is the two-site or sandwich assay (Woodhead *et al*, 1974) (Figure 1.4). As the term "two-site" suggests two antibodies are employed each being directed to unique epitopes on the antigen. One antibody is labelled (with a radioisotope in the case of IRMA) and the other is covalently coupled to a solid phase. Excess radiolabelled antibody (Ab1*) is reacted with antigen which partially fills the available binding sites. Separation of free radiolabelled antibody from antigen bound radiolabelled antibody is achieved by adding another solid phase coupled antibody (Ab2-SP) which recognises and binds to a different antigenic determinant on the antigen molecule. The quantity of the label associated with the solid phase is directly proportional to the concentration of antigen in the assay tube through the formation of the *Ab1-Ag-Ab2-SP "sandwich".

The theoretical and practical advantages of immunometric assays over competitive immunoassays have been amply documented (Miles and Hales, 1968^a; Woodhead *et al*, 1974; Ekins, 1981; Hunter and Budd, 1981; Hunter *et al*, 1983).

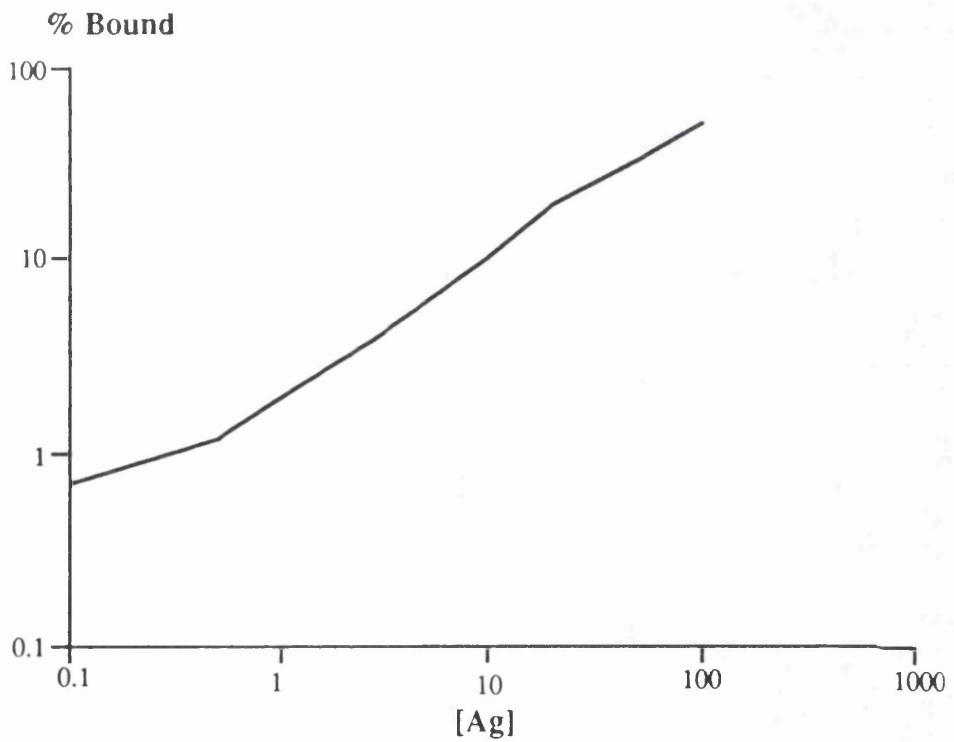
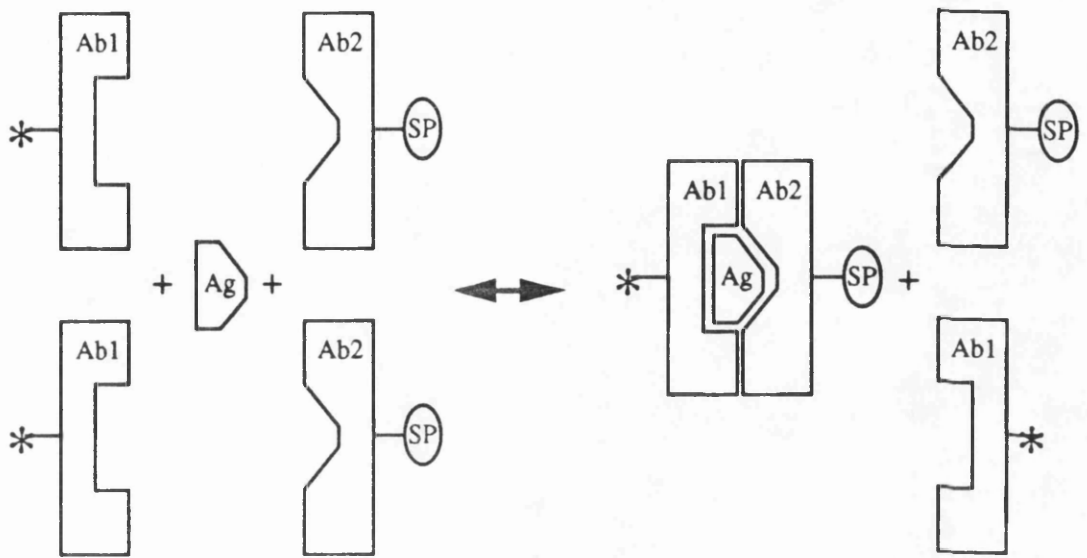

Figure 1.4 Principle of immunometric analysis and a typical dose response curve.

These include improvement in speed, increased sensitivity, wider working range, and greater specificity for intact biologically active molecules. Another factor in favour of the immunometric assay is the lack of dependence on purification and labelling of antigen, which may alter its immunoreactivity. Labelled polyclonal antibodies have found relatively restricted application in immunometric assays. This is because such assays consume large amounts of antibodies as excess reagents. Also antibodies must be purified from the bulk of serum immunoglobulin, of which it may constitute as little as 1% ,for labelling to high specific activity. Purification is achieved by specific adsorption to and elution from immobilised antigen (Hales and Woodhead, 1980). The elution of bound antibody, usually at low pH, may damage its reactivity or fail to recover the fraction with the highest avidity.

It is obvious that the properties of monoclonal antibodies are particularly suited to application in immunometric assays, and indeed overcome all the major problems associated with conventional antisera. Monoclonal antibodies for multiple distinct epitopes on a given antigen may be produced in large quantities and are easily purified. Antibodies of only moderate affinity may be used in sensitive immunometric assays with detection limits up to two orders of magnitude greater than can be achieved in competitive immunoassays with the same antibody (Buchegger *et al*, 1981; Weeks *et al*, 1981; Bosch *et al*, 1982; Van den Berg *et al*, 1982; Hunter *et al*, 1983).

1.4.4 Alternatives to Radioisotopes as Label in Immunometric Assays

The function of a label in an immunoassay is to act as a marker of the relative distribution of antigen (saturation analysis) or antibody (immunometric analysis) between bound and free fractions. The only constraint imposed on the label is that it should not interfere with the antigen–antibody reaction. Consequently many such labels have been tried including i) enzymes or their substrates or cofactors ii) luminescent compounds (either fluorescent or chemiluminescent).

The main potential of using an enzyme as a label is the amplification of signal effected by the enzyme acting on several substrate molecules. Many techniques have become established, EMIT (enzyme-multiplied immunoassay technique) and ELISA (enzyme-linked immunosorbent assay) having proved to be of particular value. ELISA utilises the two-site immunometric principle and has been developed to give assays sensitivities comparable with IRMA eg. Dako Diagnostics Ltd. amplified enzyme immunoassay. The principle of this assay is illustrated in Figure 1.5 .

Until recently fluorescent immunoassay was only practicable for analytes present in concentrations $>10^{-8}$ M because of high and variable background fluorescence. The most promising development in this area is time-resolved fluorescence immunoassay as illustrated by the 'DELFLIA' (dissociation-enhanced lanthanide fluoroimmunoassay) system marketed by Pharmacia-Wallac. Two approaches have been used to reduce background fluorescence and so increase sensitivity. Europium chelates have been used as the fluorophore. These have a large Stokes shift (difference in wavelength between incident and emitted light) and a relatively long lived fluorescence. Pharmacia-Wallac have also developed a fluorimeter which delays the measurement of emitted light by 400ms during which time non-specific background fluorescence will have largely disappeared (Soini & Hemmila, 1979). The principle of this method is illustrated in Figure 1.6 .

Chemiluminescent or bioluminescent molecules have been used in immunological reactions either directly as labels or indirectly in the quantitation by luminescence of enzyme or co-factor labelled antigens or antibodies.

Chemiluminescence is the light emitted as a consequence of the de-excitation of a reactant or a product of a particular chemical reaction. One disadvantage of these techniques is that the chemical reaction can only take place once ie. the assay cannot be recounted.

The original work in chemiluminescence immunoassay was based on the

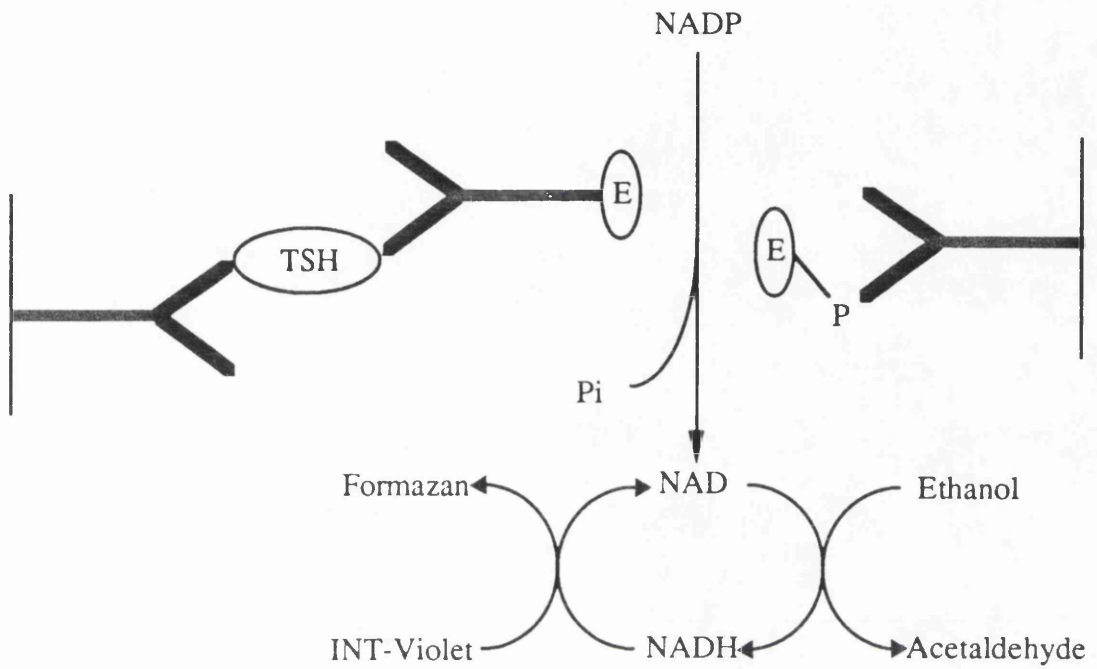

Figure 1.5 The principle of the Dako amplified enzyme immunoassay

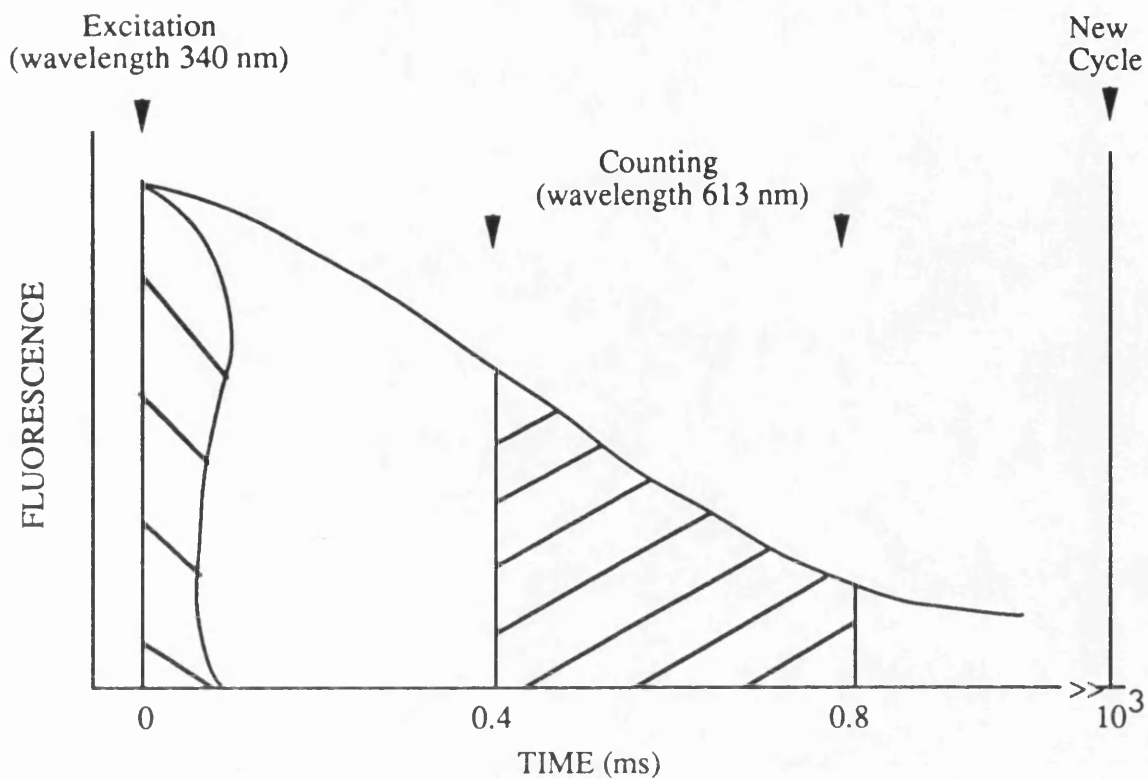

Figure 1.6 Principle of time-resolved fluorescence

luminol family of labels. Both homogeneous and separation assays for haptens based on the saturation analysis principle have been described (Collins *et al*, 1983). Figure 1.7 shows a schematic representation of the products obtained on the oxidation of luminol under basic conditions. Recently, aryl acridinium esters have received considerable attention as an alternative to luminol derivatives as labels in chemiluminescent assays. Use of acridinium esters in assays based on the two-site principle have produced some of the most sensitive assays for peptide hormones yet reported (Weeks *et al*, 1984). The signal generation system for these assays is illustrated in Figure 1.8.

Another form of chemiluminescent assay combines the attributes of luminometric measurement with the signal amplification provided by the use of enzyme labels. Originating from the studies of Whitehead *et al* (1983), assays based on the use of antibodies labelled with horseradish peroxidase and luminescent substrates have recently been launched by Amerlite Diagnostics Limited. Enhancement of the luminescent yield of the peroxidase system may be achieved by the use of phenols (Thorpe *et al*, 1985), resulting in further signal amplification and an increase in assay sensitivity.

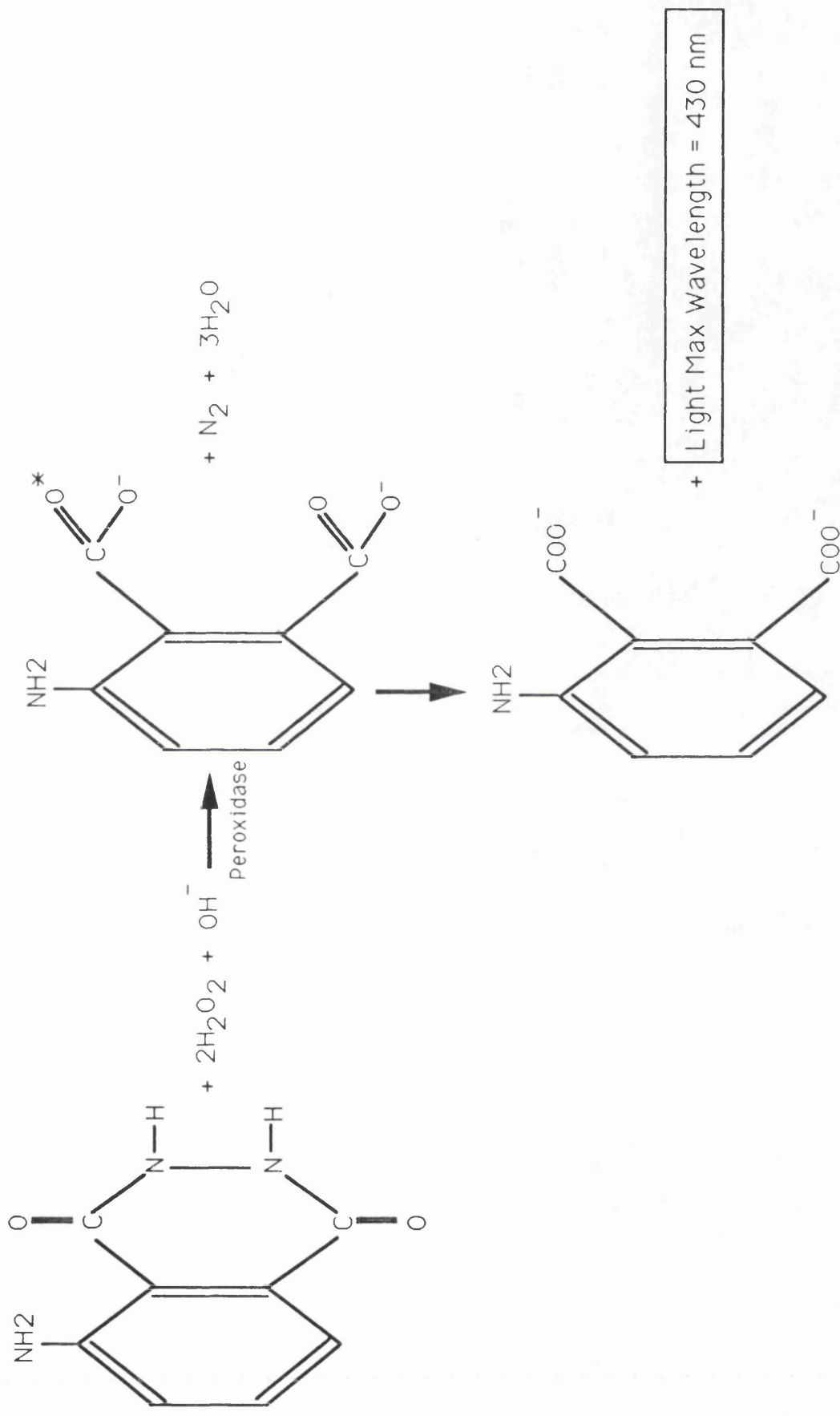

Figure 1.7 A schematic diagram showing the products obtained on oxidation of luminol.

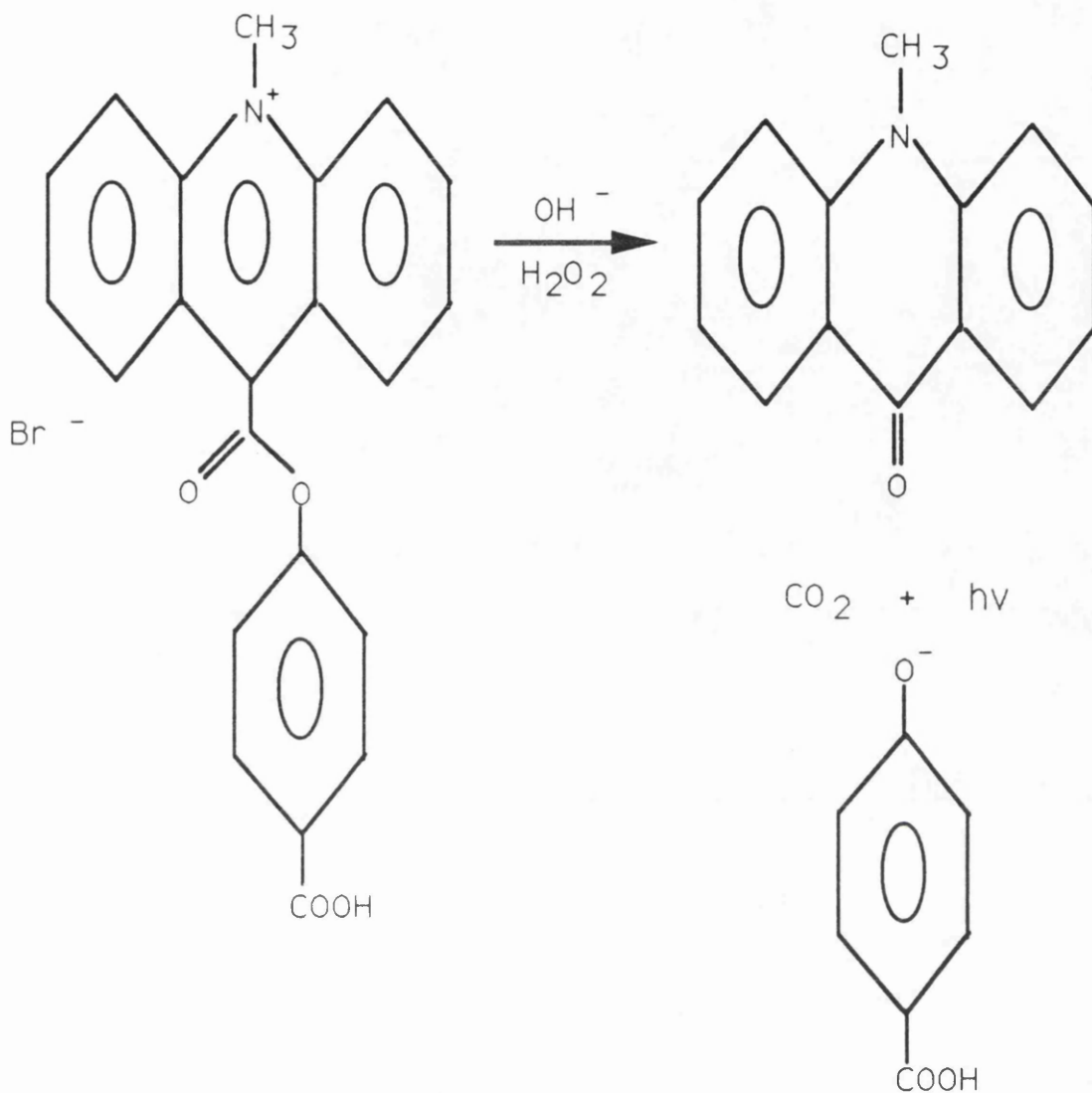

Figure 1.8 The chemiluminescent reaction of the acridinium ester *p*-carboxyphenyl-N, 10-methyl-9-carboxylate bromide.

OBJECTIVES

The objectives of this project were :-

1. To introduce into the Department of Pathological Biochemistry techniques for the production of monoclonal antibodies to a variety of peptide and protein hormones.
2. To select antibodies with suitable avidity and specificity for use in immunoassays of peptide hormones.
3. Where possible to isolate two complementary antibodies in order to develop two-site immunometric assays.
4. To validate these assays both analytically and clinically.
5. To compare and contrast the strategies tactics and outcomes when attempting to produce antibodies and develop assays to hormones of widely differing structural characteristics.
6. To evaluate the strategies adopt to rationalise future approaches.

CHAPTER 2

MATERIALS AND METHODS

2.1

MATERIALS

2.1.1 Equipment

Items other than general laboratory ware are listed indicating suppliers.

Laminar flow cabinet	Microflow Inter Med
Water jacketed 37°C incubator	Scotlab
Transplate	Northumbria Biologicals
NE 1600 gamma counter	Nuclear Enterprises
FRAC 300 fraction collector and optical detector	Pharmacia
Ultrafiltration cell	Amicon
Freeze dryer	Edwards
Sonicator	Fisons/MSE
HPLC system	Beckman

2.1.2 Disposables

Culture flasks	Corning
Culture plates 0.2 ml x 96 well Biologicals	Costar – Northumbria
Culture plates 2.0 ml x 12 well Biologicals	Costar – Northumbria
Non-sterile conical bottom 0.2 ml x 96 well plates	Nunc
Sterile pipettes	Sterilin
50 ml sterile conical tubes	Corning
Cell freezing vial	Sarstedt
Transplate cartridges	Northumbria Biologicals
Sterile pasteur pipettes	Alpha Laboratories

0.2 μ filters	Millipore
Sep-Pak cartridges	Waters
Centricon ultrafiltration/concentration cartridges	Amicon

2.1.3 Chemicals and Reagents

All chemicals used were analytical grade supplied by BDH, and synthetic peptides were supplied by Peninsula Laboratories, unless otherwise specified.

a) Chemical Reagents

Sodium 125 iodide (IMS 30) used in all iodination procedures was supplied by Amersham International. All gels used in gel filtration procedures were supplied by Pharmacia Fine Chemicals. EDC (1-ethyl-3-(3-dimethylaminopropyl) carbodiimide HCl) and Iodogen were supplied by the Pierce Chemical Company. CDI (1,1'-carbonyldiimidazole) used for coupling antibodies to Sepharose particles and N-hydroxysulphosuccinimide used to enhance the EDC conjugation of peptides to carrier proteins were supplied by Sigma Chemical Company. N-bromosuccinimide and chloramine T used in ANF iodination procedures were also supplied by the Sigma Chemical Company. HPLC grade acetonitrile and acetic acid were supplied by Rathburn Chemicals. Dynospheres magnetic particles (XP6006) were obtained from Dyno Particles A-S, Lillestrom, Norway. The proteinase inhibitor Trasylol used in ANF assay buffers was supplied by Bayer U.K. Ltd.

b) Biological Reagents

All antibodies and animal sera were obtained from the Scottish Antibody Production Unit unless otherwise indicated. Synthetic peptides PTH1-10, PTH77-84, ANF1-7 and ANF23-28 and their respective KLH conjugates were prepared and supplied by Cambridge Research Biologicals. Growth hormone for iodination was supplied by NIBSC and for immunisation was a gift from Dr S Lynch. Friends

complete and incomplete adjuvants were supplied by Difco Laboratories. Bovine serum albumin and bovine gamma globulin were purchased from the Sigma Chemical Company.

c) Tissue Culture Reagents

Murine myeloma cells (X63.Ag8.653) were supplied by Flow Laboratories and the rat myeloma cell line YB2/0 was a gift from Dr C. Milstein (MRC Cambridge). Pristane (2,6,10,14-tetramethylpentadecane) was purchased from the Sigma Chemical Company. Dimethyl sulphoxide (DMSO) and polyethylene glycol 1500 (PEG 1500) were supplied by BDH. All other reagents used in tissue culture work were obtained from Flow Laboratories.

2.1.4 Preparation of Buffers

Buffer 1 – 0.5M Phosphate Buffer

A -- 178 g di-sodium hydrogen orthophosphate dihydrate dissolved in distilled water and made to a volume of 2 litre.

B -- 39 g sodium di-hydrogen orthophosphate dissolved in distilled water and made to a volume of 500 ml.

Solution A titrated with B to pH 7.4.

Buffer 2 – EPPS Buffer

25.23g EPPS – (4- [2 - hydroxyethyl] – 1 - piperazine – propane sulphonic acid)

0.5g sodium azide

The above reagents were dissolved in distilled water and the pH adjusted to 8.0 with 4M sodium hydroxide. Tween-20 (2ml) was then added and the final volume adjusted to 1 litre with distilled water.

Buffer 3 – Gel Filtration Column Elution Buffer

100ml	0.5M phosphate buffer (buffer 1)
5.0g	bovine serum albumin
1.0g	sodium azide

Dissolved in distilled water and made to 1 litre.

Buffer 4 – GH Assay Buffer

995 ml	EPPS buffer (buffer 2)
5.0 ml	sheep serum

Prepared fresh weekly and stored at 4°C.

Buffer 5 – PTH Assay Buffer

200 ml	0.5M phosphate buffer (buffer 1)
9.0 g	sodium chloride
2.0 g	sodium azide
18.6 g	sodium EDTA
10.0 g	bovine serum albumin (protease free) -- ICN Biochemicals
2.0 ml	Tween-20

The above reagents were dissolved in distilled water and the final volume adjusted to 1 litre by further addition of distilled water. Immediately prior to use 0.5 ml 30% w/v hydrogen peroxide was diluted to 100 ml with the above buffer.

Buffer 6 – ANF Assay Buffer

100 ml	0.5M phosphate buffer pH 7.4
1.0g	bovine serum albumin
9.0g	sodium chloride
1.0g	sodium azide
3.72g	sodium EDTA
5x10 ⁵ KIU	trasyolol

The above were dissolved in distilled water and the volume made to 1 litre.

Buffer 7 – Acetate Buffer

A -- 8.2 g of anhydrous sodium acetate dissolved in distilled water and made to 1 litre.

B -- 5.7 ml of glacial acetic acid diluted to 1 litre with distilled water.

Solution B titrated with A to pH 4.0

Buffer 8 – TAPS Buffer

24.3 g TAPS – ([2-hydroxy – 1, 1 – bis (hydroxymethyl) – ethyl] amino) – 1 – propanesulphonic acid)

Dissolved in distilled water and adjusted to pH 8.6. Final volume was adjusted to 1 litre with distilled water.

Buffer 9 – Protein A Binding Buffer

56.3 g glycine
87.6 g sodium chloride

Dissolved in 450 ml distilled water. The pH was then adjusted to 9.0 with 5M sodium hydroxide prior to making the volume to 500 ml with distilled water.

Buffer 10 – Protein A Elution Buffers/Regeneration Buffer

8.7 g citric acid dihydrate

Dissolved in 450 ml distilled water and the pH adjusted as required with 5M sodium hydroxide

2.1.5 Preparation of Standards

a) Growth Hormone

The contents of an ampoule of GH standard (IRP 66/217) were dissolved in 0.5 ml of 0.05M phosphate buffer pH 7.4 containing 0.1% BSA. The solution was made volumetrically to 500 ml with 0.05M phosphate buffer containing 0.1% BSA to give a stock standard of 700000 mU/l. This material was aliquoted in 1 ml amounts and stored at -80°C . Working standards were prepared by appropriate dilution in assay buffers.

The working standards UK7 and UK8 supplied by EQAS were used according to the suppliers instructions.

b) Parathyroid Hormone

PTH(1–84) standards were prepared from synthetic PTH supplied by Peninsula Laboratories. The contents of a vial (20 ug) were dissolved in 2 ml 0.05M barbitone buffer pH 8.6 containing 0.5% BSA. Aliquots ($100\ \mu\text{l} \equiv 1\ \mu\text{g}$) were stored at -80°C as a concentrated standard. Further dilution of $100\ \mu\text{l}$ of

concentrated standard to 10 ml with barbitone buffer produced a stock standard at a concentration of 10 ng/100 μ l. This was also aliquoted (100 μ l) and stored at -80°C .

Working standards were prepared freshly for each assay. Stock standard (100 μ l) was diluted 1/20 with equine serum and further dilutions, also in equine serum, were prepared producing working standards of 500, 250, 62.5, 15.6, 3.9 and 0.98 pmol/l.

c) Atrial Natriuretic Factor

Atrial natriuretic factor standards were prepared from synthetic ANF 99–126 supplied by either Bachem or Peninsula Laboratories. Contents of vials were dissolved in 1 ml distilled water and then volumetrically made to 25 ml. Aliquots (0.5 ml) were stored at -80°C . Further dilutions to appropriate concentrations were made in ANF assay buffer when required. Met[O] ANF 99–126 standards were prepared in the same manner from material supplied by Peninsula Laboratories.

2.2

METHODS

2.2.1 Isolation of IgG Fractions of Antisera and Ascitic Fluids

The n-octanoic acid precipitation method of Steinbuch and Audran (1969) was used to prepare IgG fractions of antisera and ascitic fluids unless otherwise indicated.

Antisera or ascitic fluids (10 ml) were titrated to pH 5.0 with 0.1M acetic acid and 0.9 ml of a 91% solution of n-octanoic acid added dropwise while constantly stirring. Constant agitation was continued for 30 minutes prior to centrifugation at 1500g for 20 minutes. The supernatant was retained, and the precipitate washed with 20 ml of 0.1M sodium bicarbonate pH 8.0 by constant

mixing for a further 30 minutes. Following re-centrifugation of the washed precipitate the supernatants were pooled and placed in an Amicon ultrafiltration cell fitted with a Diaflow PM10 filter, washed under pressure (15 psi) with 0.1M sodium bicarbonate to remove the n-octanoic acid, and then concentrated. The protein concentration of the recovered solution was then assayed.

2.2.2 Protein Estimation

Protein concentrations of IgG extracts were determined by the method of Schacterle and Pollack (1973), this method being a modification of that of Lowry *et al* (1951).

Reagents

a) Alkaline Copper Reagent

Sodium carbonate (10g) was dissolved in 50 ml of 1M sodium hydroxide. Potassium tartrate (100 mg) and cupric sulphate (50 mg) were separately dissolved in 2–3 ml of distilled water and then added to the sodium carbonate solution. The volume was then adjusted to 100 ml with distilled water.

b) Folin–Ciocalteu Reagent

Supplied by BDH was diluted 1:25 with distilled water prior to use.

c) Protein Standards

A stock solution was prepared by dissolving 50 mg of bovine serum albumin in 50 ml of distilled water. Working standards were serial x2 dilutions of this stock in distilled water.

Method

Protein estimation were carried out in duplicate. Aliquots (200 µl) of standard or

sample were mixed with 200 µl of alkaline copper reagent and incubated for 10 minutes at ambient temperature. Dilute Folin–Ciocalteu reagent (1 ml) was then added, the tubes vortexed and placed in a water bath at 55°C for 5 minutes. Tubes were rapidly cooled by placing them in cold water for 2 minutes. Absorbance was measured at a wavelength of 650 nm in 10 mm glass cuvettes within 30 minutes. A standard curve was constructed from which the sample concentration was determined.

2.2.3 Coupling of Antibodies to Sepharose Particles

Coupling of antibodies to Sepharose CL4B proceeds in two stages, activation and coupling.

Activation

Sepharose particles were activated essentially by the method of Chapman and Ratcliffe (1981) described for cellulose particles.

The particle concentration of a suspension of Sepharose CL4B was adjusted to 20 mg/ml by allowing a gel suspension to settle in a measuring cylinder overnight, removing the supernatant and adjusting the total volume with distilled water to twice that of the settled gel. Calibrated gel (200 ml) was placed in a 37 µ porosity sintered glass Buchner funnel and dehydrated by successive washes under negative pressure with 250 ml of distilled water, 30%, 50% and 70% v/v acetone in distilled water, and 100% acetone. Care was taken not to allow the gel to dry.

The dehydrated gel was then transferred to a glass conical flask and the volume adjusted to 200 ml with acetone. Carbonyldiimidazole (4.87g) was then added. The flask was sealed with a ground glass stopper and gently stirred for 60 minutes. After transferring the gel back to the Buchner funnel rehydration was accomplished by reversing the dehydration procedure. The final rehydration wash was with EPPS buffer pH 8.0 after which the activated gel was transferred to a calibrated poly-carbonate bottle and the volume adjusted to 200 ml.

Coupling

Coupling is performed immediately after gel activation. Purified IgG (120 mg) was added to the activated gel and mixed for 18 hours at ambient temperature. IgG remaining in solution was recovered in the supernatant following centrifugation for 10 minutes at 1000g. This was then re-concentrated in an ultrafiltration cell for future use. The recovered gel was then subjected to centrifugation/wash cycles with 2 x 200 ml of 0.5M sodium bicarbonate pH 8.0 and 2 x 200 ml of 0.1M acetate buffer pH 4.0. Washing was achieved by rotating for 20, 20, and 60 minutes then 18 hours respectively with centrifugation and aspiration of supernatants to change buffers. Finally the gel was washed with 0.9% sodium chloride and then EPPS buffer pH 8.0 containing 0.1% sodium azide and 0.1% bovine serum albumin. The final volume was adjusted to 200 ml to give a particle concentration of 20 mg/ml. Gel was stored at 4°C until required.

Batch preparations of different sizes were accomplished by proportional alterations of volumes.

2.2.4 Radioiodination Methods

Antigen and antibody iodinations were performed by the solid-phase lactoperoxidase method of Karonen *et al* (1975) unless otherwise indicated. The chloramine T (Hunter and Greenwood, 1962), Iodogen (Fraker and Speck, 1978) and N-bromosuccinimide (Reay, 1982) methods were used to iodinate ANF (see Chapter 5).

Lactoperoxidase Method

Antigens 2–5 µg or antibodies 20 µg in 10–20 µl of either distilled water or 0.5M phosphate buffer pH 7.4 were iodinated by the addition of the following:–

- 10 or 20 µl 0.5M phosphate buffer pH 7.4
- 10 µl solid-phase lactoperoxidase (locally prepared)

5 or 10 μl	sodium ^{125}I iodide (18.5 or 37 MBq)
10 μl	hydrogen peroxide (30% w/v stock diluted 1/20000 with distilled water)

The mixture was vortexed and incubated at ambient temperature for 15 minutes and the reaction terminated by dilution with 200 μl of buffer 3 or 80 μl of distilled water followed by centrifugation at 500g for 2 minutes.

Chloramine T Method

20 μl	0.5M phosphate buffer pH 7.4
20 μl	peptide 5 μg
10 μl	sodium ^{125}I iodide (37 MBq)
10 μl	chloramine T (1 mg/ml) in 0.05M phosphate buffer

Contents were mixed and incubated for 30 seconds

The reaction was terminated by the addition of 10 μl sodium metabisulphite (2 mg/ml in 0.05M phosphate buffer) and further diluted with 80 μl of distilled water.

Iodogen Method

Iodogen (1,3,4,6-tetrachloro-3 α ,6 α -diphenylglycouril) (25mg) was dissolved in 100 ml of dichloromethane. Aliquots (50 μl _ 5 μg iodogen/tube) were dispensed into conical bottomed polypropylene tubes and allowed to dry in air. These tubes were then capped and stored in a dessicator at -20°C until required.

5 μg	Iodogen
20 μl	0.5M phosphate buffer pH 7.4
20 μl	peptide 5 μg
10 μl	sodium ^{125}I iodide (37 MBq)

Contents were mixed and incubated for 10 minutes

The reaction was terminated by the addition of 100 μl of distilled water and

transferring the reaction mixture to a clean tube.

N-Bromosuccinimide Method

N-bromosuccinimide (0.01M) was freshly prepared by dissolving 0.178 g in distilled water and adjusting the final volume to 100 ml. This stock solution was further diluted 1/100 for use in the following procedure.

20 µl	0.5M phosphate buffer pH 7.4
20 µl	peptide 5 µg
10 µl	sodium ¹²⁵ I iodide (37 MBq)
10 µl	N-bromosuccinimide

Contents were mixed and incubated for 15 seconds

The reaction was terminated by the addition of 10 µl sodium metabisulphite (2 mg/ml in distilled water) and further diluted with 80 µl of distilled water

2.2.5 Preparation of Conjugates for use as Immunogens

a) Parathyroid Hormone

PTH(1-34) and PTH(53-84) peptides were coupled to bovine serum albumin by the carbodiimide method of Orth (1979). PTH(1-10) with and additional C-terminal cysteine residue and PTH(76-84) with an additional N-terminal cysteine residue were custom synthesised and conjugated to keyhole limpet haemocyanin by Cambridge Research Biochemicals. A bis-diazotised tolidine linkage was used producing, respectively, C and N terminally bound peptides.

b) Atrial Natriuretic Factor

ANF 99-105 and ANF 121-126 were custom synthesised and conjugated to keyhole limpet haemocyanin by Cambridge Research Biochemicals. ANF 99-105 was C-terminally linked and ANF 121-126 was N-terminally linked using a N-maleimidobenzyl-N'-hydroxysuccinimide ester.

Albumin conjugates of ANF 99–126, ANF 99–105, ANF 121–126, ANF 99–109 and ANF 111–126 were prepared by the method of Staros *et al* (1986). The utility of carbodiimide conjugation methods has been limited by low coupling yields. Staros *et al* (1986) have reported the use of N-hydroxysulphosuccinimide as an enhancing agent of water soluble carbodiimide-mediated coupling reactions claiming a ten fold increase in efficiency. EDC, 1-ethyl-3-(3-dimethylaminopropyl) carbodiimide hydrochloride and N-hydroxysulphosuccinimide were supplied by Pierce. Crystalline bovine serum albumin (fraction V) was supplied by Sigma.

Briefly, 32.5 mg of BSA and 7.75 mg N-hydroxysulphosuccinimide (HSS) were dissolved in 1 ml of distilled water. EDC (178 mg) was also dissolved in a further 1 ml of distilled water. Peptide (0.5 mg) was weighed into a tube and dissolved in 125 μ l of distilled water, 50 μ l of BSA/HSS solution, 25 μ l of EDC and 25 μ l of I^{125} ANF 99–126 (50000 cpm) were added. Following incubation at ambient temperature for 90 minutes the mixture was applied to a Sephadex G50 gel filtration column and eluted with 0.05M phosphate buffer pH7.4. The absorbance of the column eluant at 214 nm was continuously monitored and 1 ml fractions were collected. The radioactivity in each tube was also assessed and used to calculate the coupling ratio.

2.2.6 Immunisations

Conjugates/peptides in saline (0.2 ml) were emulsified by sonication in an ice bath with 0.6 ml of Freund's adjuvant (complete adjuvant for primary immunisations and incomplete adjuvant for subsequent immunisations). Mice were given intraperitoneal injections and rats multisite subcutaneous injections (Vaitukaitis *et al*, 1971) of 0.1 ml of emulsion using a 26g 0.5 inch hypodermic needle. Injection doses were calculated to be equivalent to between 5 and 20 μ g of peptide. Secondary immunisations were at 2–3 week intervals following the

primary. Three days prior to fusions donor mice were injected intravenously via the tail vein with 5 µg of peptide in 0.1 ml of sterile physiological saline. Rats were given this pre-fusion dose via the jugular vein.

2.2.7 Test Bleeds

Mice were anaesthetised with ether, the ventral tail vein punctured with a sterile 23g hypodermic needle and the exuding blood absorbed onto filter paper card to form a discrete spot. Mice were colour coded to aid identification. Blood spots were allowed to dry prior to a 6 mm disc being punched into a test tube containing 0.5 ml of 0.9% saline. This approximated to an initial dilution of 1/250 i.e. 0.002 ml serum/6mm disc. Bleeds were assessed for the presence of specific antibody as described in section 2.2.9. .

2.2.8 Monoclonal Antibody Production

Monoclonal antibodies were produced by the method of Kohler and Milstein (1975) with local adaptations. Myeloma cell lines used in hybridisation experiments were either murine X63.Ag 8.653 cells (Kearney *et al*, 1979) or rat YB2/O cells (Kilmartin *et al*, 1982).

a) Culture of Myeloma Cells

i) Culture Medium

100 ml RPMI 1640 (Rothwell Park Memorial Institute) buffered with 20 mmol/l HEPES (N-2-hydroxyethylpiperazine-N'-2-ethanesulphonic acid).

10 ml heat inactivated foetal bovine serum

1 ml glutamine (200 mmol/l)

2 ml penicillin/streptomycin (5000 U/ml and 5 mg/ml respectively)

1 ml fungizone (250 µg/ml)

ii) Maintenance

Cells were counted daily using a Neubauer haemocytometer and cell density was maintained between 2.5×10^5 cells/ml and 1.2×10^6 cells/ml by appropriate dilution in fresh media. Viability was assessed using a trypan blue dye exclusion method. When in logarithmic growth doubling time was approximately 18 hours. The number of cells maintained was expanded in the week leading up to a hybridisation experiment so that on the day of the experiment 150×10^6 cells were available. Immediately prior to hybridisation experiments these cells were washed three times with RPMI 1640 and three 5 ml aliquots in RPMI 1640 prepared, each containing 50×10^6 cells.

b) Preparation of Mouse Peritoneal Macrophages

Mouse peritoneal macrophages were used as feeder cells to support the growth of hybrids at low cell density. Three balb/c mice were killed and dissected to reveal the peritoneum. Syringes fitted with 19 gauge needles were used to inject 5 ml of RPMI 1640 into their abdominal cavities. The abdomen was massaged to suspend peritoneal cells and the RPMI 1640 withdrawn into the syringe. Washings were pooled into a 50ml sterile conical tube and centrifuged for 5 minutes at 500g. The supernatant was decanted and the cells re-suspended in RPMI 1640 and counted. Cells were then diluted in hybrid culture medium (myeloma cell culture medium plus a further 10 ml of foetal bovine serum) to a density of 30000 cells/ml and distributed to culture wells or flasks as appropriate.

c) Preparation of Spleen Lymphocytes

Immediately prior to hybridisation experiments the previously selected mouse was killed and the spleen removed using aseptic techniques and placed in a

sterile tube containing 5 ml RPMI 1640. Further manipulations were conducted in a laminar flow cabinet. The spleen was placed in a sterile petri dish and fatty tissue was removed. The spleen was then cut in half and the cells teased from the capsule using scalpel blades. The contents of the dish were transferred to a tube and the large fragments of tissue allowed to settle. The suspended cells were transferred to another tube and centrifuged for 5 minutes at 500g. The supernatant was then decanted and the cells resuspended in 15 ml RPMI 1640. An aliquot (100 μ l) was taken, the red cells lysed, and spleen lymphocytes counted. Three 5ml aliquots of suspended cells were prepared each containing approximately 50×10^6 cells.

d) Preparation of Polyethylene Glycol 1500 (PEG)

Polyethylene glycol 1500 (10 g) was weighed into a measuring cylinder and 5ml of RPMI 1640 added. The cylinder was then placed in a 50°C water bath until the PEG liquified. The pH was adjusted to approximately 7.0 with 0.1M sodium hydroxide, the phenol red in the RPMI 1640 acting as the indicator. The volume was then made to 20 ml with further pre-warmed RPMI giving a 50% w/v solution. The PEG solution was then sterilised by filtration through a 0.2 μ filter.

e) Hybridisation Protocol

The day prior to a hybridisation experiments peritoneal macrophages were harvested, suspended in hybrid culture medium (myeloma cell culture medium plus a further 10 ml of foetal bovine serum) and dispensed into fifteen 96 x 0.2 ml well sterile flat bottomed microtitre plates (100 μ l/well = 3000 cells/well). The aliquots of prepared spleen cells (50×10^6) and myeloma cells (50×10^6) were mixed and centrifuged at 500g for 10 minutes. The supernatant was decanted and the universal bottle containing the cell pellet placed in a beaker of water at 37°C. Pre-warmed (37°C) 50% w/v PEG (0.8 ml) was added dropwise over one

minute while gently agitating the cells. After a further minute of mixing 10 ml of pre-warmed RPMI 1640 was added over five minutes, gradually increasing the rate of dilution to avoid osmotic shock. Cells were then centrifuged at 500g for ten minutes and washed with 2x20 ml RPMI 1640 finally being resuspended in 60 ml of pre-warmed culture medium supplemented with a further 10 ml of inactivated foetal calf serum and HAT (hypoxanthine/aminopterin/thymidine – 100, 0.4 and 16 $\mu\text{mol/l}$, respectively). The hybridisation products were then transferred, using a Transplate 96 (Northumbria Biologicals) into 5 96x0.2 ml well microtitre plates (0.1 ml/well) pre seeded with peritoneal macrophages. All plates were sealed with sellotape and incubated at 37°C for 10–14 days before examination for the presence of growing hybrids. This procedure was repeated for each of the three aliquots of myeloma and spleen cells.

2.2.9 Screening Assays

All wells containing growing hybrids were screened for the presence of specific antibody by radioimmunoassay. Approximately 0.15 ml of culture supernatant was removed aseptically from each well, fresh medium replaced and the plate returned to the incubator.

Cell supernatants (50 μl) were incubated overnight at ambient temperature with 100 μl (20000 cpm) of appropriate ^{125}I labelled antigen. Sepharose coupled sheep anti-mouse γ -globulin (1mg/0.2 ml) was added and the tubes incubated on an orbital shaker at 300 rpm for 60 minutes. The Sepharose particles were then washed with 3x2 ml 0.9% sodium chloride containing 0.2% Tween 20 (v/v) and following the final centrifugation and aspiration the radioactivity in the bound fraction was counted. Bound radioactivity was expressed as a percentage of the total radioactivity added. Cell supernatants giving binding greater than 10% were further studied to assess antibody avidity by displacement analysis.

Cell supernatants were diluted 1:3, 1:9, 1:27 etc. and analysed in the

presence of a displacement dose of appropriate antigen (GH = 50 mU/l, PTH 1–84 = 500 pmol/l). Displacement was calculated $(B_0 - B_d / B_0 \times 100\%)$ where B_0 = binding in the absence of antigen and B_d = binding in the presence of antigen) at each dilution with those wells giving the greatest displacement, therefore highest avidity, being selected for cloning.

2.2.10 Cloning and Propagation

Following identification of wells containing cells secreting antibody of interest these cells were diluted to 1.5 ml in culture medium in a well of a 12x2 ml plate. This cell suspension was then dispensed into the first column (8 wells – 100 μ l/well) of a 96x0.2ml plate which had previously been seeded with peritoneal macrophages (100 μ l/well approx 3000 cells) as previously described. The cell suspensions in the wells of the first column were then double diluted into the next column and this dilution repeated across the twelve columns of the plate. Culture medium was then added to each well to bring the volume to 0.2 ml, the plate was then sealed and placed in a 37°C incubator. Cell growth was monitored daily and screening of growing hybrids undertaken after approximately fourteen days.

The cell suspension remaining in the 2 ml well was supplemented with media containing peritoneal macrophages and also placed in the incubator. When the cell density expanded sufficiently these cells were transferred to a 25 ml flask in 5 ml of macrophage supplemented media and following expansion a 75 ml flask. When sufficient cells were generated and maintained in logarithmic growth with a viability, as measured by dye exclusion, of >90% they were frozen and stored in liquid nitrogen. This provided a back up should cloning fail or the cloning plate be contaminated.

Screening of cloning plates was performed as described in section 2.2.9. . The selection criteria for further cloning were antibody characteristics and highest initial dilution (i.e. furthest to the right on the plate while maintaining the presence

of antibody secreting cells). Two or three wells from each initial cloning plate were selected for further cloning. Each of these were also propagated in 2 ml wells and flasks for back up purposes.

Following the second cloning procedure and appropriate screening selected cells were expanded in flasks for both freezing and *in vivo* propagation.

2.2.11 Freezing and Recovery of Cells

All cell lines were stored frozen in liquid nitrogen. Cells in culture were centrifuged at 500g for 10 minutes the culture medium discarded and replaced with 10% v/v dimethylsulphoxide in foetal calf serum previously cooled to 4°C. This solution was initially added dropwise with gentle agitation of the cell pellet, to give a final concentration of 3–5 x10⁶ cells/ml. Aliquots (1 ml) were transferred to cryovials were placed in a polystyrene box and froze slowly to –80°C. After sixteen hours vials were transferred to liquid nitrogen for long term storage.

Recovery of cells was achieved by rapid thawing at 37°C. Cells were diluted in 20 ml RPMI 1640 and centrifuged at 500g for ten minutes. The cell pellet was then resuspended in 1 ml of culture medium and transferred to a 25 ml flask containing 4 ml of medium supplemented with macrophage feeder cells.

2.2.12 Propagation of Hybridomas *in vivo*

Mice to be used for *in vivo* propagation of hybridomas were primed by the intraperitoneal injection of 0.5 ml pristane (2,6,10,14–tetramethyl pentadecane) at least one week before the intraperitoneal injection of 2x10⁶ hybridoma cells. Hybridoma cells were prepared for injection by centrifugation, washing and finally resuspending in RPMI 1640 to a cell concentration of 4x10⁶/ml. Following inoculation mice were observed daily for evidence of abdominal distention. When present ascitic fluid was collected, following anaesthetisation with diethyl ether, by puncturing the abdomen with a 19g hypodermic needle and allowing the fluid to

drain under gravity. The fluid was clarified by centrifugation and stored at -20°C until required. In general this procedure was repeated every 2–3 days throughout the remaining life–span of the animals. Ascitic fluid obtained in this way was further purified for assay use by either the method described in section 2.2.1 or that described in section 6.3.1. .

2.2.13 Isotyping of Monoclonal Antibodies

Mouse monoclonal antibody typing kits supplied by Serotec were used for antibody immunoglobulin class and subclass determination.

The immunodiffusion plate was removed from its sealed sleeve, opened and allowed to equilibrate to ambient temperature so that condensation could evaporate from the gel surface. Test culture supernatant (75 μl – containing 1–20 mg/l antibody) was placed in the large central well of one of the rosettes. The six antisera supplied, directed against directed against the mouse immunoglobulin classes and subclasses IgG1, IgG2a, IgG2b, IgA and IgM, were individually transferred (100 μl) to the six outer wells of the same rosette. The plate was then tightly closed and stored flat at ambient temperature for 24–48 hours. After this time the immunoprecipitate relevant to the immunoglobulin specificity was visible.

2.2.14 Data Reduction and Error Analysis Methods

All dose response curves were prepared using a mass action model (Malan *et al*, 1978) data reduction program on an Apple IIGS microcomputer. This WHO program was supplied by Dr P. Edwards, Middlesex Hospital, London. The program also calculated precision profiles as described by Ekins (Ekins & Edwards, 1983). The basis of this computation is to obtain estimates of the error associated with each dose. The errors in the response (R) for a given dose (D) are assumed to be normally distributed around the mean value and this variation can be defined algebraically as :-

$$\text{SD of dose estimation } (\delta D) = \frac{\text{SD of the response estimation } (\delta R)}{\text{slope of the dose response curve}}$$

$$\delta D = \frac{\delta R}{\delta R/\delta D}$$

The slope and/or the error (R) changes with dose, implying that the observed δD will differ over the concentration range of interest. This changing relationship between δD and D is the precision profile.

CHAPTER 3

GROWTH HORMONE : THE PRODUCTION OF A MONOCLONAL ANTIBODY AND ITS APPLICATION TO AN IMMUNORADIOMETRIC ASSAY

$$\text{SD of dose estimation } (\delta D) = \frac{\text{SD of the response estimation } (\delta R)}{\text{slope of the dose response curve}}$$

$$\delta D = \frac{\delta R}{\delta R/\delta D}$$

The slope and/or the error (R) changes with dose, implying that the observed δD will differ over the concentration range of interest. This changing relationship between δD and D is the precision profile.

3.1.1. Structure of Growth Hormone

Human growth hormone is a globular protein having a molecular weight of 22000 daltons. It consists of a single polypeptide chain of 191 amino acid residues and it has two disulphide bridges. These bridges are between residues 53 and 165, and 182 and 189 (Figure 3.1). Little is known of the tertiary structure of growth hormone mainly because suitable crystals for x-ray diffraction studies have not yet been successfully prepared (Philips, 1987).

3.1.2. Biosynthesis of Growth Hormone

Biosynthesis of growth hormone takes place in the pituitary somatotrophs. These acidophilic cells are located predominantly in the lateral wings of the anterior pituitary and characterised by the presence of membrane bound secretory granules measuring 368 ± 60 nm (SD) in diameter (Daughaday, 1985).

The genes involved in growth hormone biosynthesis are located on a long arm of chromosome 17 and are closely related to chorionic somatomammotrophin genes (Figure 3.2a). The growth hormone/chorionic somatomammotrophin gene family is composed of multiple copies of the growth hormone and chorionic somatomammotrophin genes, all of which are remarkably similar (Chawla *et al*, 1983; Miller and Eberhardt, 1983). The extent of sequence homology in coding and non-coding regions is 90 – 95%. Each of the genes has five coding sequences (exons) separated by four intervening sequences (introns). The positions and lengths of these four introns are identical for all members of this gene family. The GH1 gene codes the authentic 22K growth hormone while the GH2 gene codes the 20K variant. The 20K variant differs from 22K growth hormone by the internal deletion of 15 amino acid residues, residues 32–46 (Lewis *et al*, 1980; Denotto *et al*, 1981). A schematic representation of the transcription, processing and

Figure 3.1 Primary structure of human growth hormone.

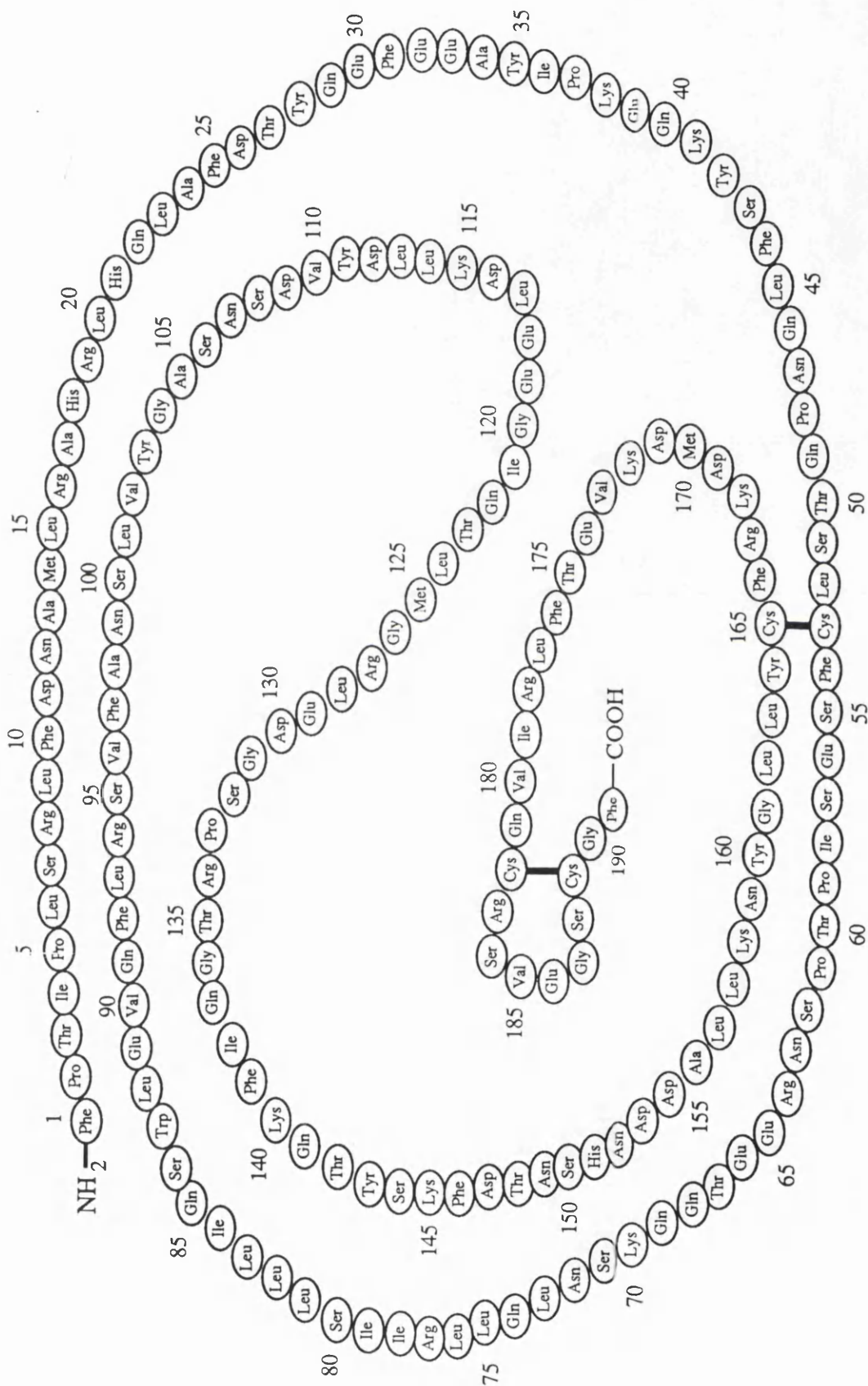

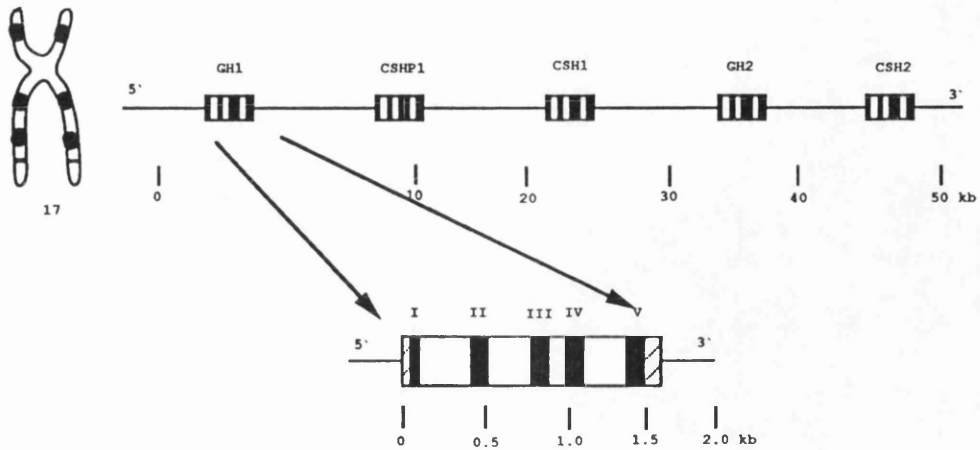

Figure 3.2a The growth hormone/chorionic somatomamotrophin gene family

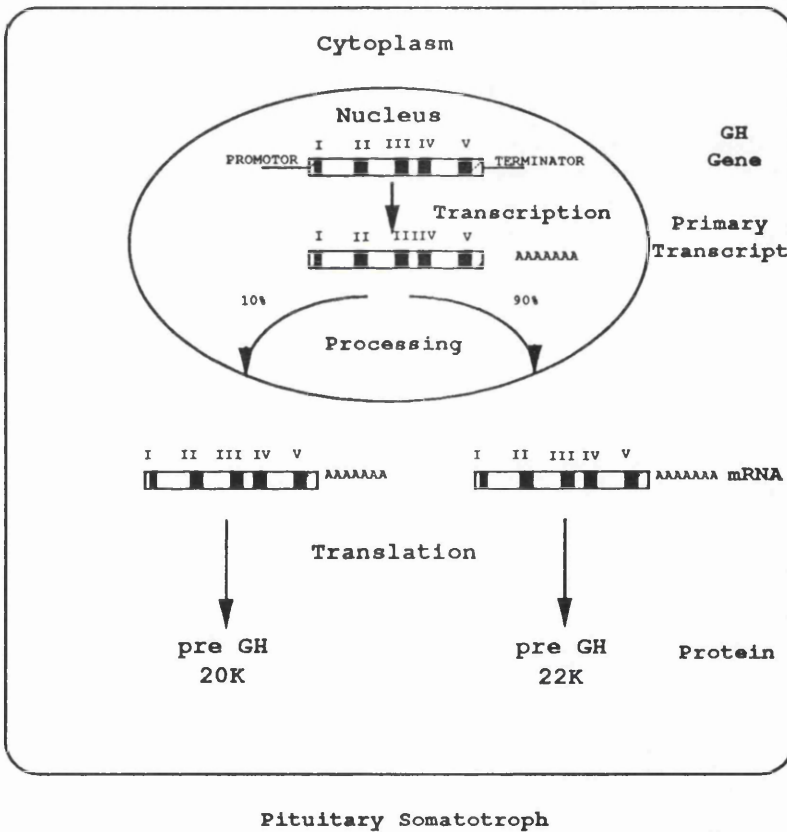

Figure 3.2b Schematic representation of the biosynthesis of growth hormone

translation of the growth hormone genes is shown in Figure 3.2b.

Additional size and charge variants of growth hormone have been reported and these include two 24K variants, 45K dimers and forms with molecular weights >100000 (Chawla *et al*, 1983; Wright *et al*, 1974).

The existence of a short lived precursor comprised of an additional 26 amino acids at the N-terminus has been described (Bancroft *et al*, 1976).

Growth hormone is the most abundant hormone in the human pituitary gland, the anterior lobe of which contains 5–10 mg stored in secretory granules (Daughaday, 1985).

3.1.3. Factors Controlling Plasma Growth Hormone Levels

Secretion from the anterior pituitary is primarily under the control of two hypothalamic peptides, growth hormone releasing hormone (GHRH) and somatostatin.

GHRH has been described variously as a 40, 44 and 37 amino acid peptide all of which were originally derived from pancreatic GHRH secreting tumours (Guillemin *et al*, 1982; Rivier *et al*, 1982). There remains some discussion as to the exact nature of hypothalamic GHRH.

Somatostatin can exist as 14 and 28 amino acid peptides both of which inhibit growth hormone secretion (Reichlin, 1985).

The secretion and or activity of GHRH and somatostatin are modulated by neurotransmitters, dopamine, noradrenaline, serotonin and enkephalin. A great number of metabolic, hormonal and pharmacological factors can effect growth hormone release by modifying the release of these neurotransmitters (Table 3.1)(Daughaday, 1985). Growth hormone and insulin-like growth factor I (IGFI also known as somatomedin-C) concentrations also effect the release of somatostatin thus completing a classical feedback loop.

IGFI, a 70 amino acid, straight chain, basic peptide, may also act directly on

Table 3.1

FACTORS INFLUENCING NORMAL GROWTH HORMONE SECRETION

	<u>Augmentation</u>	<u>Inhibition</u>
Neurogenic	<ol style="list-style-type: none">1. Stages III and IV sleep2. Stress (traumatic, psychogenic, infectious, surgical)3. α-Adrenergic agonists4. β-Adrenergic antagonists5. L-dopa	<ol style="list-style-type: none">1. REM sleep2. Emotional Deprivation3. α-Adrenergic antagonists4. β-Adrenergic agonists
Metabolic	<ol style="list-style-type: none">1. Hypoglycaemia2. Falling fatty acid concentration3. Amino acids4. Uncontrolled diabetes5. Uraemia6. Hepatic cirrhosis	<ol style="list-style-type: none">1. Hyperglycaemia2. Rising fatty acid concentration3. Obesity
Hormonal	<ol style="list-style-type: none">1. GHRH2. Oestrogens3. Glucagon4. Vasopressin	<ol style="list-style-type: none">1. Somatostatin2. Hypothyroidism3. Large doses of corticosteroids

the pituitary to inhibit GHRH-stimulated secretion of growth hormone (Underwood and Judson, 1985).

3.1.4. Physiological Effects of Growth Hormone

For many years the actions of growth hormone appeared to be paradoxical, the growth promoting effects on muscle and skeletal tissue being insulin-like effects, while the diabetogenic effects on carbohydrate metabolism and lipolytic effects on adipose tissue were antagonistic to the effects of insulin. Resolution of this paradox came with the somatomedin hypothesis of growth hormone action (Salmon and Daughaday 1957) (Figure 3.3). Accordingly the growth hormone effects on carbohydrate and lipid metabolism are direct whereas the growth promoting actions are mediated through the somatomedin family of peptides.

Two somatomedin peptides, with molecular weights of approximately 7500 daltons, have been isolated and because of structural similarities to proinsulin these have been termed IGF I (formerly somatomedin C) and IGF II. The overlapping biological activities of insulin and the IGF's may be due to the fact that the IGF's cross react with the insulin receptor and that insulin cross reacts with the IGF I receptor.

3.1.5. Plasma Growth Hormone Estimations in Clinical Practice

The primary role of growth hormone estimation is in the diagnosis of acromegaly and in the investigation of the causes of short stature. Growth hormone concentrations in plasma describe a distinct circadian rhythm, and this along with stress stimulated release, makes single estimations of little value (Parker *et al*, 1979). Several dynamic tests are available to overcome this problem.

Active acromegaly is characterised by hypersecretion of growth hormone usually as a consequence of a somatotroph adenoma. The diagnosis can best be made by showing failure of suppression of plasma growth hormone after an oral

Figure 3.3 Physiological effects of growth hormone

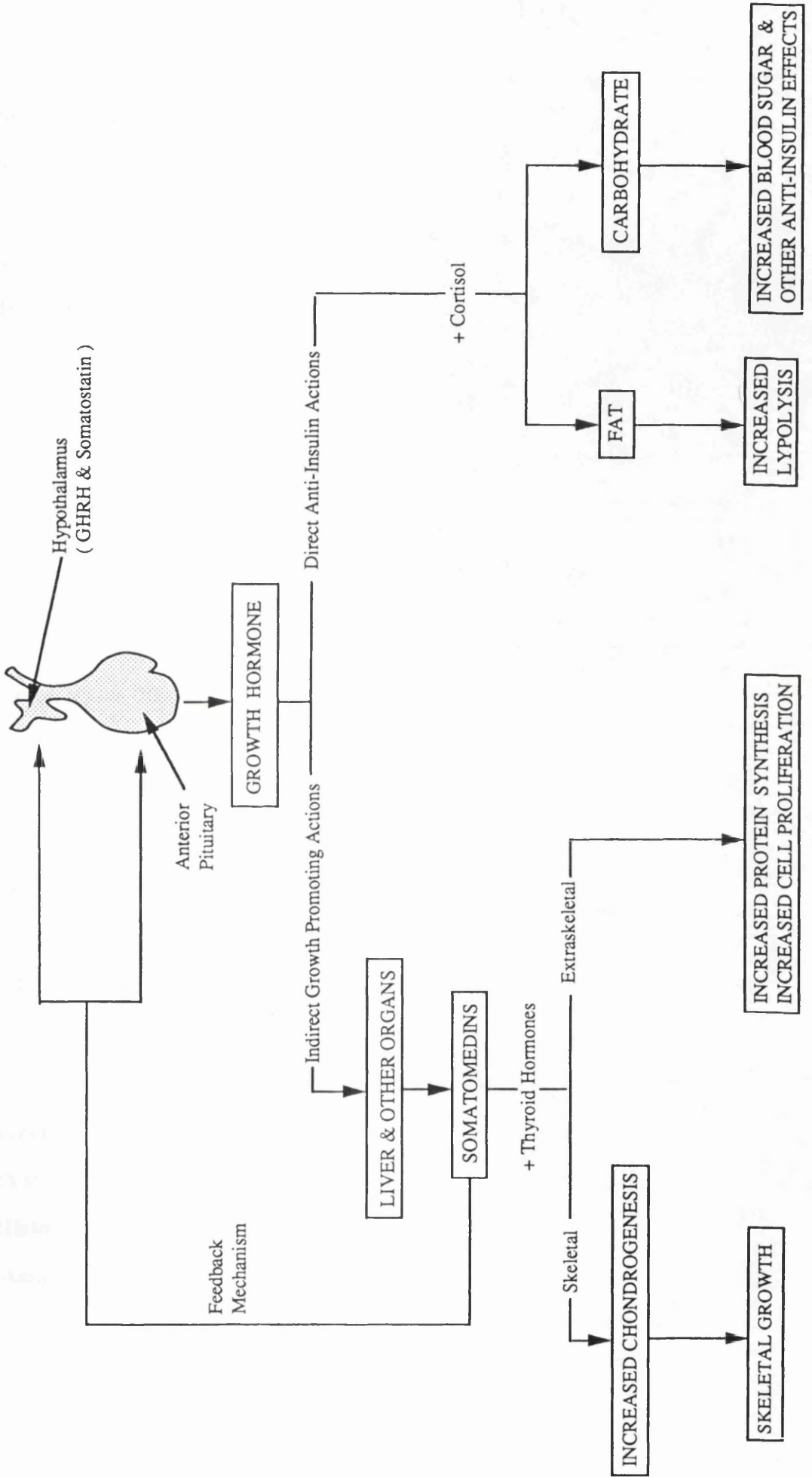

glucose load. In normal subjects plasma growth hormone falls below 2 mU/l at some point during an oral glucose tolerance test (GTT) (In: Scottish Inter-Laboratory Services Directory, 1987 ; Stewart *et al*, 1989). In acromegaly the common finding is an elevated fasting growth hormone concentration (>10 mU/l) which shows little or no suppression during the GTT.

Investigation into the endocrine causes of short stature involves the assessment of growth hormone reserve. The simplest screening procedure is to measure growth hormone concentrations before and after strenuous exercise. The stress of exercise is normally sufficient to raise growth hormone concentration to >20 mU/l. A response such as this would exclude inadequate growth hormone reserve. A blunted or absent response however is not considered diagnostic. The most widely used test of growth hormone reserve is the insulin tolerance test. The stress of hypoglycaemia is normally sufficient to raise growth hormone concentration above 20 mU/l at some point during the test. Clinical symptoms of hypoglycaemia should be observed, and threshold levels of sex steroids demonstrated, if results are to be valid. This test is obviously not without risk and consequently the alternative clonidine stimulation test has been advocated (Gil-Ad *et al*, 1979). Clonidine (2[2,6-dichlorophenyl)-amino]-2-imidazoline) is a widely used anti-hypertensive drug the only side effects of which are drowsiness for a few hours and occasionally mild hypotension . Clonidine induction of growth hormone secretion is by specific activation of α -adrenergic receptors (Gil-Ad *et al*, 1979). Growth hormone responses are similar to those seen during insulin induced hypoglycaemia.

A summary of tests of growth hormone reserve is shown in Table 3.2.

3.1.6. History of the Development of Growth Hormone Assays

Assays of human growth hormone can be divided into four major groups:-

1. Bioassays
2. Radioreceptor assays

Table 3.2

CLINICAL TESTS OF GROWTH HORMONE RESERVE

<u>Screening Tests</u>	<u>Test conditions</u>	<u>Time of Growth Hormone Response</u>
Exercise	Patients should be fasting; 15 minutes moderate exercise, then 5 minutes vigorous exercise.	20-40 minutes after exercise began.
Sleep	Growth hormone rise occurs with deep sleep (EEG stages 3 & 4)	Initial peak within 1 hr after onset of deep sleep.
<u>Formal Tests</u>		
Insulin	Regular crystalline insulin 0.05 - 0.15 U/Kg (i.v.)	45 - 75 min
Arginine	L-Arginine monohydrochloride, 5 - 10 % solution,	60 - 120 min
L-dopa	0.5 g/1.73 m ² orally	45 - 120 min
Glucagon	0.03 mg/Kg i.m. or s.c.	120 - 180 min
Clonidine	4 ug/Kg orally	60 - 120 mins

3. Radioimmunoassays

4. Immunometric assays

Bioassays, while remaining fundamental to the measurement of activity of purified growth hormone and providing the basis for comparison of reference standards, are too insensitive and non-specific for valid measurement of growth hormone in blood and tissue fluids. The rat tibial width assay is most commonly used and is also the most sensitive (Greenspan *et al*, 1949). Over a limited range of growth hormone doses, the growth of the proximal tibial epiphyseal cartilage in the hypophysectomised rat is linearly related to the logarithm of the dose of growth hormone administered.

Radioreceptor assays using receptors from a variety of sources have been described. Those using binding to a human lymphocyte cell line have proved to be quite specific whereas others using receptors derived from rabbit, or rat liver show a much wider responsiveness. (Lesniak *et al*, 1973; Gavin *et al*, 1982; Lesniak *et al*, 1974). The receptor assays combine to some extent the sensitivity and precision of radioimmunoassays with the biological relevance of bioassays. The receptor assay of choice, however, requires the availability of tissue culture facilities thus limiting its wide-spread use.

The development of the radioimmunoassay for growth hormone (Hunter and Greenwood, 1962) and the improvements in radioiodination techniques (Hunter and Greenwood, 1964) heralded an explosion in the knowledge of the physiology and pathophysiology of growth hormone secretion. The establishment of an international reference preparation (IRP 66/217) and the introduction of a U.K. external quality assessment scheme overcame the initial problems of between laboratory variation. Radioimmunoassay thus became, and has remained, the most universally used method for the estimation of growth hormone in plasma for over 25 years.

Immunometric assays for growth hormone first described in 1968 (Miles and

Hales), and the subsequently developed two-site immunometric assay, whilst having considerable theoretical advantages over the limited reagent radioimmunoassay methods, did not initially realise their potential. This was primarily due to the use of labelled polyclonal antibodies since the practical difficulties of antibody purification and iodination are considerable. The profligate use of antibody in excess reagent assays was also a significant disadvantage.

Surprisingly, when monoclonal antibodies specific for growth hormone were first produced they were applied to radioimmunoassay methods (Bundesen *et al*, 1980). A comparison of the use of monoclonal antibodies in radioimmunoassay and immunoradiometric assay, illustrated by α -foetoprotein (Hunter and Budd, 1981), clearly demonstrated the benefits of the use of monoclonal antibodies in excess reagent methods. Subsequent to these observations several such assays for growth hormone have been developed and this technique is gradually replacing the radioimmunoassay as the method of choice.

Immunometric assays utilising tracers other than radioiodine have also been described. Weeks and Woodhead (1986) developed an immunochemiluminometric assay using an acridinium ester labelled monoclonal antibody as tracer; and Sukegawa *et al* (1988) have described an enzyme immunoassay which utilizes an antibody peroxidase conjugate. The bound activity of the conjugate is assayed by fluorimetry using 3-(p-hydroxyphenyl)propionic acid as substrate.

3.2. MONOCLONAL ANTIBODY PRODUCTION

Detailed protocols for monoclonal antibody production and assessment are described in Chapter 2, sections 2.2.7 to 2.2.13.

3.2.1. Immunisation and Assessment of Response

Six female balb/c mice were immunised with human growth hormone. Each mouse received a primary and two secondary doses of immunogen at three week intervals. Responsiveness was assessed by comparison of serum antibody titres two weeks after the final dose of immunogen. Blood samples were taken onto filter paper and antibody dilution curves prepared.

Figure 3.4 shows that all mice responded with M3–M6 having much higher titres than M1 and M2. Mouse 3, with the greatest antibody titre, was selected for hybridisation. Three days prior to the hybridisation experiment a priming dose of 5 μg of growth hormone in 0.1 ml of saline was administered intravenously.

3.2.2. Hybridisation Experiment

Splenectomy provided a spleen weighing 390 mg, from which 156×10^6 cells were recovered. Myeloma cells (X63. Ag8.653), on the day of the experiment, had an estimated viability of 87%. The ratio of spleen cells to myeloma cells for fusions was 1:1. Three separate fusions were performed, the products of each fusion being dispensed, in 2x HAT medium, into the wells of five 96 x 0.2 ml microtitre plates. Peritoneal macrophages, harvested the day prior to the hybridisation experiment, were used as feeder cells at a density of 5×10^3 cells/well.

3.2.3. Assessment of Fusion Experiment and Selection of Hybrids.

Hybrid growth was observed in all wells. Supernatants were removed for testing ten days after fusion. A summary of the results of the primary screening

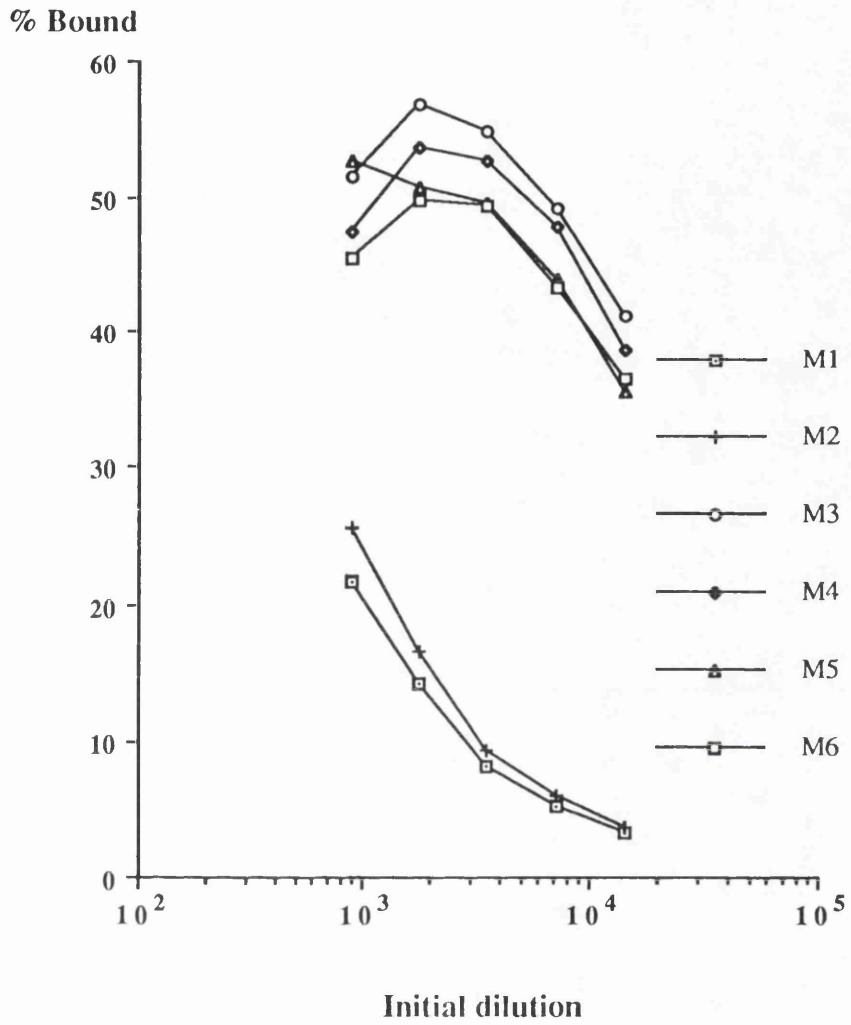

Figure 3.4 Antibody titres of balb/c mice immunised with growth hormone.

assay is shown as a frequency distribution of percentage binding (Figure 3.5). 98.8% of wells (1423) gave binding in excess of 20%. Further study of 1423 wells was considered impractical. It was decided to investigate further the 75 supernatants which gave binding in excess of 50% and also the three plates which contained the largest number of supernatants giving binding in excess of 40%.

A total of 339 supernatants were therefore examined on a secondary screening assay, using a displacement dose of 56 mU/l GH, designed to assess the relative avidities of antibodies. The results of this secondary screen are similarly presented as a frequency distribution of % inhibition (Figure 3.6). The twelve most avid (greatest % inhibition) were selected for cloning.

3.2.4. Cloning and Propagation of Selected Hybrids.

Cloning was performed by a limiting dilution technique. Feeder cells, peritoneal macrophages, were provided to aid growth at low cell densities. Supernatants were removed for testing 14 days post cloning. The initial test for the presence of antibody revealed that only 8 of the 12 cloned continued to secrete anti-GH antibody. The results from a typical cloning plate are shown in Table 3.3.

Displacement tests were performed on the supernatants from wells at highest dilution still showing the presence of antibody secreting cells. The condition and number of cells in these wells was noted. Also observations were made as to whether there was significant cell growth in wells, in the same row, at higher dilution which did not secrete antibody. Supernatants from two plates were found to have lost the displacement characteristics shown originally.

Only two of the remaining six survived 2nd and 3rd cloning stages, retaining their binding and displacement characteristics. These were the cell lines coded GH3/H10 and GH3/G8. When sufficient numbers of cells had been cultured aliquots were frozen. Isotyping of the antibodies from these cells by immunodiffusion demonstrated IgG1 immunoglobulins in both cases.

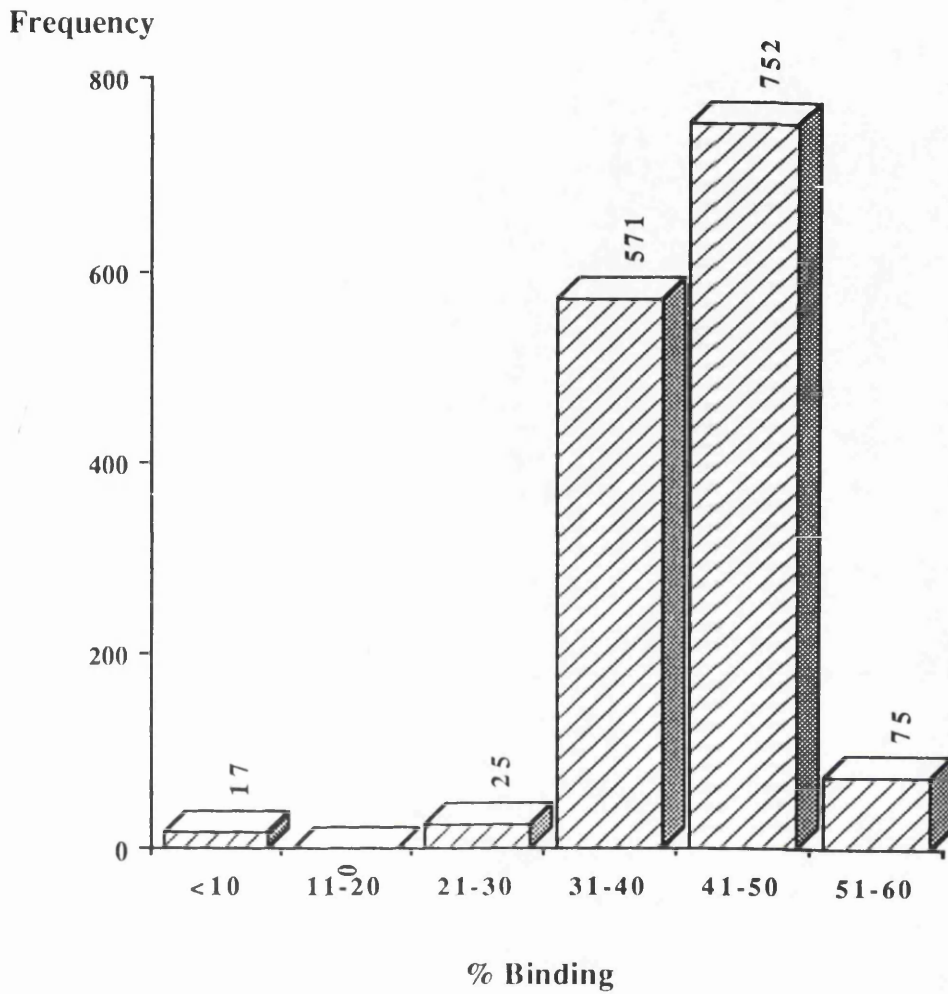

Figure 3.5 Production of monoclonal antibodies for growth hormone: results of primary screening assay.

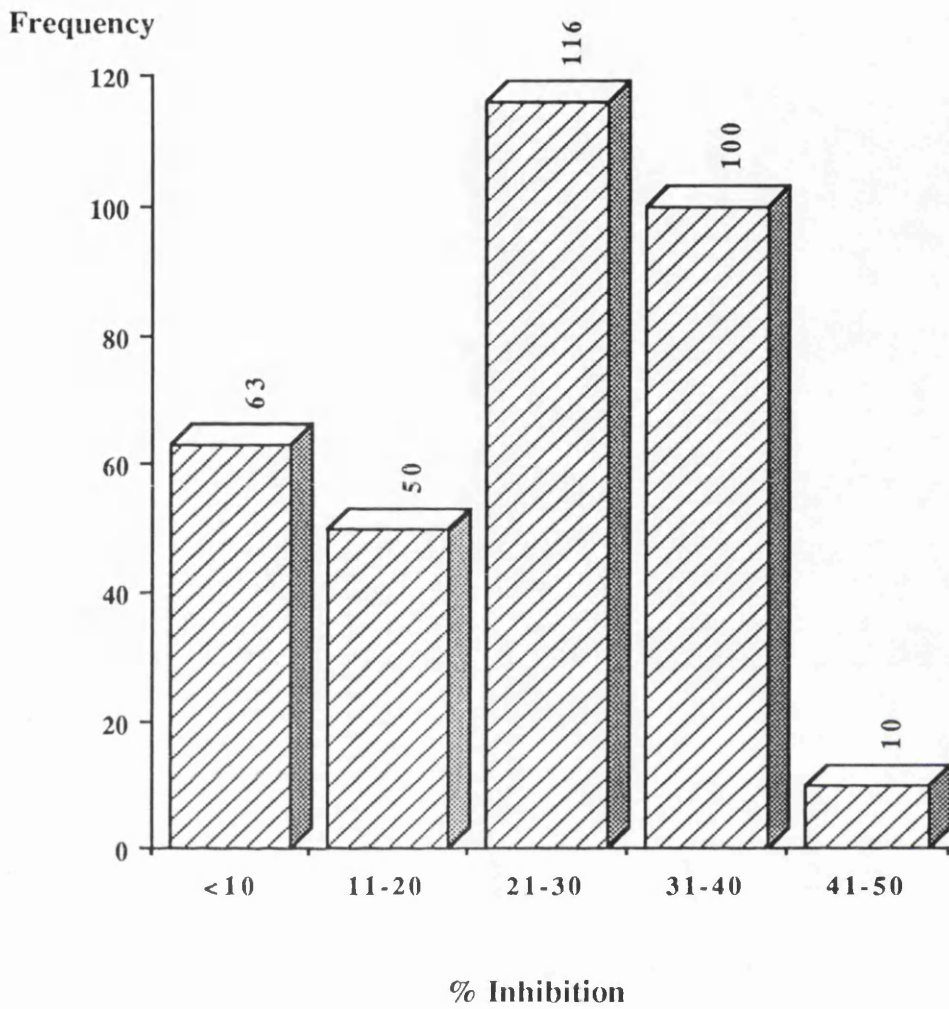

Figure 3.6 Production of monoclonal antibodies for growth hormone: results of displacement studies.

**Table 3.3 A TYPICAL CLONE PLATE SHOWING PERCENTAGE BINDING FOR INDIVIDUAL WELLS.
* INDICATES SUPERNATANTS NOT TESTED.**

	1	2	3	4	5	6	7	8	9	10	11	12
<u>A</u>	*	*	*	31.0	23.7	16.9	14.3	3.3	1.4	*	*	*
<u>B</u>	*	*	*	28.3	27.2	22.3	17.9	3.1	1.5	*	*	*
<u>C</u>	*	*	*	29.8	29.3	20.2	20.3	16.9	2.1	*	*	*
<u>D</u>	*	*	*	29.1	22.4	24.2	20.4	15.0	8.8	*	*	*
<u>E</u>	*	*	*	31.1	26.2	22.5	15.6	11.2	14.4	*	*	*
<u>F</u>	*	*	*	28.6	25.6	18.1	11.4	16.7	1.5	*	*	*
<u>G</u>	*	*	*	29.8	27.1	19.8	18.4	8.8	1.8	*	*	*
<u>H</u>	*	*	*	30.2	24.3	20.7	15.7	3.5	17.1	*	*	*

Ascitic fluid containing antibody was generated by the intraperitoneal injection of $5-10 \times 10^6$ hybridoma cells, in 0.5 ml of RPM1 1640, into pristane primed balb/c mice. Five mice were used for each hybridoma cell line. Taps of ascitic fluid were taken when there was evidence of abdominal distention, approximately 3–4 weeks post injection, and then at about three day intervals as necessary. The cell line GH3/G8 gave a very poor yield, only one mouse being tapped on more than one occasion. In contrast GH3/H10 cells generated good volumes of ascitic fluid on four occasions from four of the five mice injected.

Fluid, from third and fourth taps, generated by the GH3/H10 cell line were pooled and the immunoglobulin fraction extracted by the method described in Chapter 2 section 2.2.1. The protein content of the purified material was 7.4 mg/ml. This material was diluted in distilled water and aliquoted at a concentration of 20 $\mu\text{g}/20 \mu\text{l}$ and subsequently used for radioiodination.

3.3. DEVELOPMENT OF A TWO SITE IMMUNORADIOMETRIC ASSAY

The antibodies used in the development of the two-site immunoradiometric assay were the monoclonal antibody GH3/H10, labelled with ^{125}I , and a SAPU sheep anti-GH antibody, coupled to Sepharose CL-4B.

3.3.1. Radioiodination of GH3/H10 Antibody

Radioiodination was by the lactoperoxidase method as described in Chapter 2, section 2.2.4, using 20 μg of monoclonal antibody and 37 MBq of ^{125}I iodine. Post iodination purification was by gel filtration chromatography on a 60 x 1.6 cm column of Sepharose CL-6B. The elution buffer was buffer 3 pumped at a flow rate of 10 ml/hr. Fractions (1ml) were collected and intrinsic radioactivity counted for 10 seconds.

The iodination profile (Figure 3.7) shows two peaks. The first peak comprises the iodinated immunoglobulin followed by a peak of excess radioiodine.

Counts $\times 10^{-3}$

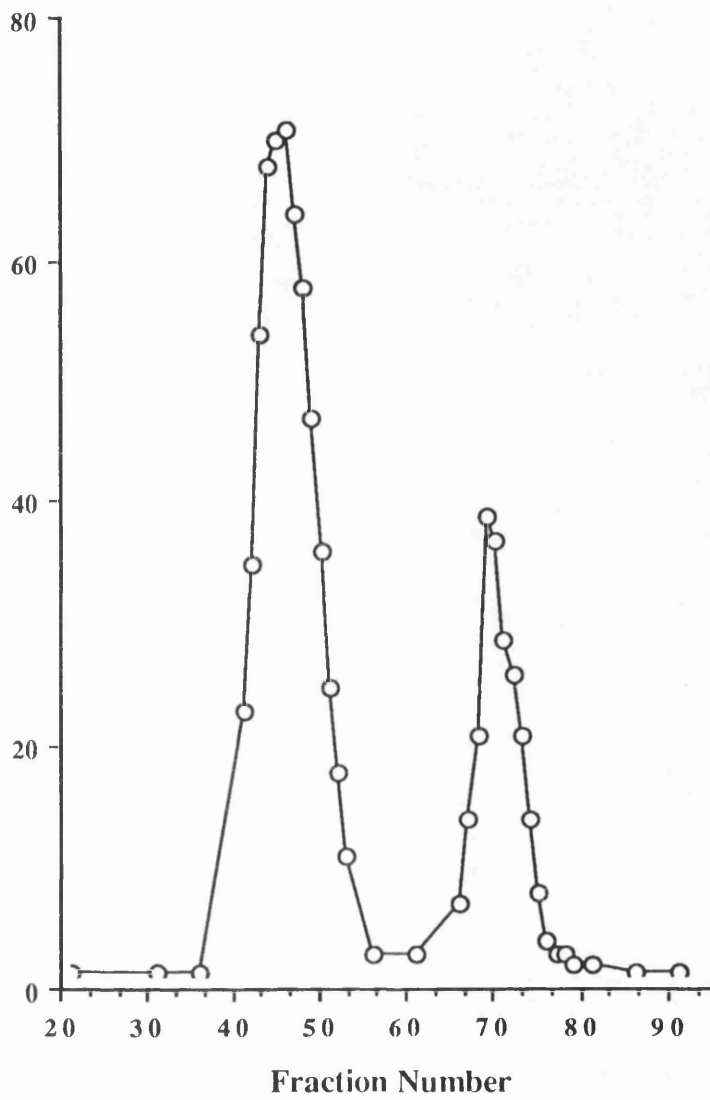

Figure 3.7 Lactoperoxidase radioiodination of GH3/H10 monoclonal antibody

Calculated from the areas under the peaks the percentage of ^{125}I Iodine incorporated into the immunoglobulin is 74%. This translates to a specific radioactivity of 1.369 MBq/ μg immunoglobulin.

3.3.2. Preparation of Solid-Phase Sheep Anti-GH

A partially purified immunoglobulin fraction from sheep anti-GH antiserum was prepared by n-octanoic acid precipitation and coupled to Sepharose CL-4B by the methods described in Chapter 2, section 2.2.1 and 2.2.3 respectively. The final product was stored at 10 mg/ml Sepharose CL-4B in buffer 4 at 4 °C.

3.3.3 Compatibility of GH3/H10 with the Sheep Anti-GH

For optimal performance a two-site IRMA requires a pair of antibodies which recognise distinctly different antigenic binding sites, or epitopes. In this context compatibility of two antibodies can be demonstrated by the production of a dose response curve.

Growth hormone standards were prepared covering the range 0–560 mU/l. Duplicate aliquots of growth hormone standards (0.1 ml) were incubated static at ambient temperature with radiolabelled GH3/H10 monoclonal antibody (0.1 ml = 2 ng) for 90 minutes. Sepharose CL-4B coupled sheep anti-GH (0.2 ml = 2mg) was then added and incubated for a further 90 minutes with shaking. The Sepharose particles were then subjected to three centrifuge/wash cycles with 2ml of saline. Bound radioactivity was counted for 60 seconds.

The resultant dose response curve is shown as Figure 3.8. The percentage radioactivity bound rises from 0.45% at zero dose to 31.6% at 140 mU/l GH, a change of 70 fold. Binding is maintained at 560 mU/l GH, indicating sufficient binding capacity of the solid-phase antibody to avoid misclassification of growth hormone measurement in normal clinical practice due to the high dose-hook effect.

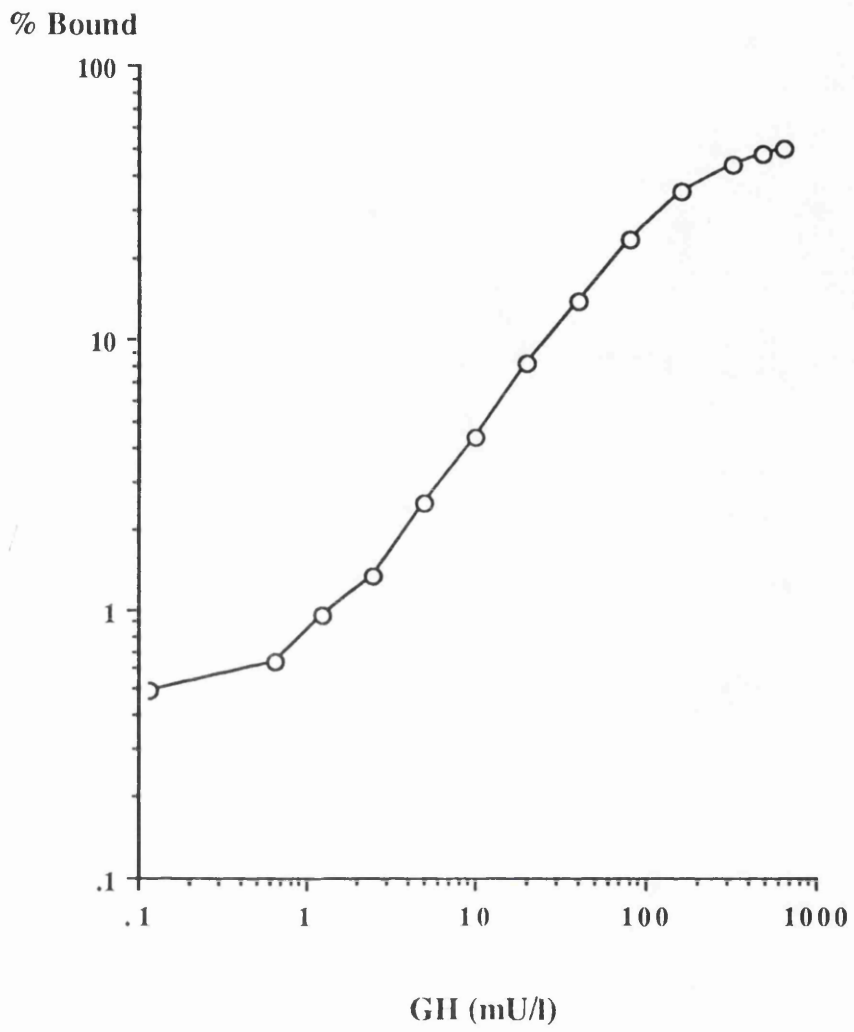

Figure 3.8 Initial dose response curve for growth hormone IRMA.

3.3.4. Preliminary Optimisation of Assay Conditions

In the optimisation of a two-site IRMA several major factors require consideration i.e. precision and bias, the extent of the working range, speed and convenience. The final product is a balance of these various factors.

Studies were performed varying buffer pH and protein content, radiolabelled antibody mass and specific activity, solid-phase antibody mass, incubation times and solid-phase wash conditions. The effects of varying conditions were assessed arbitrarily on the basis of improvements in signal/noise ratio (the product of binding at 140 mU/l GH and 0 mU/l GH) and more specifically the precision profile and the concentration at which a hook effect occurred. In the interests of brevity data from the many individual experiments is excluded. The overall optimised conditions are as follows:-

- a) Buffer- 0.1M EPPS buffer pH 8.0 containing 0.5% non-immune sheep serum and 0.2% Tween-20.
- b) ^{125}I Anti-GH - specific radioactivity 555-740 Bq/ μg , adding 100,000 cpm/tube.
- c) Solid-phase anti-GH - 0.5 mg/tube in 0.2 ml assay buffer
- d) Incubation periods - i) 120 minutes - sample and ^{125}I anti-GH
ii) 60 minutes - post addition of solid-phase anti-GH
- e) Wash conditions - 4 x 2 ml of saline.

3.3.5. Standardisation

The solvent used in the preparation of standards can have a significant effect on assay bias. Various potential matrices were evaluated by estimating the recovery of exogenous growth hormone standard added to serum samples.

Three serum samples with growth hormone concentration of 2.1, 7.3, and 16.0 mU/l, as measured by RIA, were each supplemented with 8.75 and 17.0 mU/l

of growth hormone standard. The growth hormone concentrations in both supplemented and basal samples were measured in five assays each of which had a different standard matrix. Figure 3.9 shows the five standard curves from which serum concentrations were interpolated.

The recoveries of exogenous growth hormone from each of the samples is shown in Table 3.4. The values in italics are the concentrations of the basal samples derived from each of the standard curves. The phosphate buffer based standards give basal values closest to those of the RIA, however the recovery of only 62% hormone was unacceptable. The EPPS buffer standards appeared to give the best balance between comparability with RIA and recovery.

An ideal standard matrix would be growth hormone free human serum. Two approaches to the production of growth hormone free serum were considered, either immunoextraction, or the physiological suppression of growth hormone in normal volunteers by the administration of an oral glucose load.

Immunoextraction was attempted using sheep anti-GH coupled to Sepharose CL-4B. A pilot experiment was conducted to determine the mass of solid phase antibody required to remove all the growth hormone from a human serum sample from a normal volunteer. To 6 x 1 ml of serum 50 μ l of ^{125}I growth hormone was added (10,000 cpm). An increasing mass of solid phase anti-GH was added to five of the tubes covering the range 0.5 – 4.0 mg/tube. The sixth tube was used as a reference and buffer was added in place of the solid phase anti-GH. All tubes were mixed, end over end, for 6 hours prior to centrifugation and removal of 0.1 ml aliquots for counting. The tubes were mixed for a further 18 hours and a further aliquot removed for counting. Figure 3.10 shows the percentage of ^{125}I growth hormone remaining in the sample, relative to the mass of solid phase anti-GH added, for both incubation periods. Since there was no apparent improvement beyond 1 mg of solid phase/ml of serum this ratio was used on a larger scale without the addition of ^{125}I growth hormone.

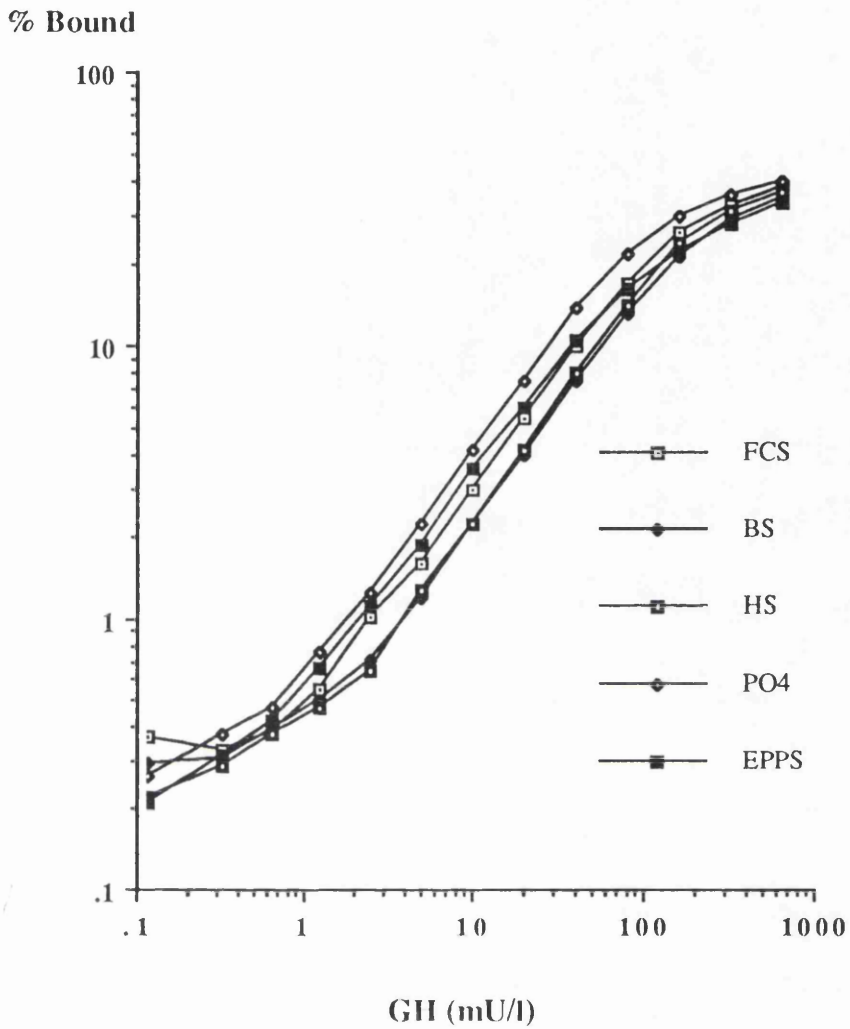

Figure 3.9 Effect of standard matrix on dose response curve for growth hormone IRMA.

FCS = Foetal calf serum : BS = Bovine serum : HS = Horse serum :
 PO4 = Phosphate buffer : EPPS = EPPS buffer.

Table 3.4 RECOVERY OF ADDED GROWTH HORMONE FROM THREE SERUM POOLS AS A FUNCTION OF STANDARD MATRIX.

Standard Matrix	P1			P2			P3			Average %Recovery
	Basal conc.mU/l	+8.75mU/l %Recovery	+17.0mU/l %Recovery	Basal conc.mU/l	+8.75mU/l %Recovery	+17.0mU/l %Recovery	Basal conc.mU/l	+8.75mU/l %Recovery	+17.0mU/l %Recovery	
Foetal Calf Serum	4.4	99	83	10.9	75	74	19.5	86	91	85
Bovine Serum	6.1	119	120	14.0	114	106	28.5	114	121	116
Horse Serum	5.6	125	118	14.2	101	114	26.5	109	109	113
PO ₄ Buffer pH 7.4	2.6	61	67	7.3	51	52	13.2	72	68	62
EPPS Buffer pH 8.0	1.8	81	89	5.7	91	88	17.0	80	91	87

**% GH
Extracted**

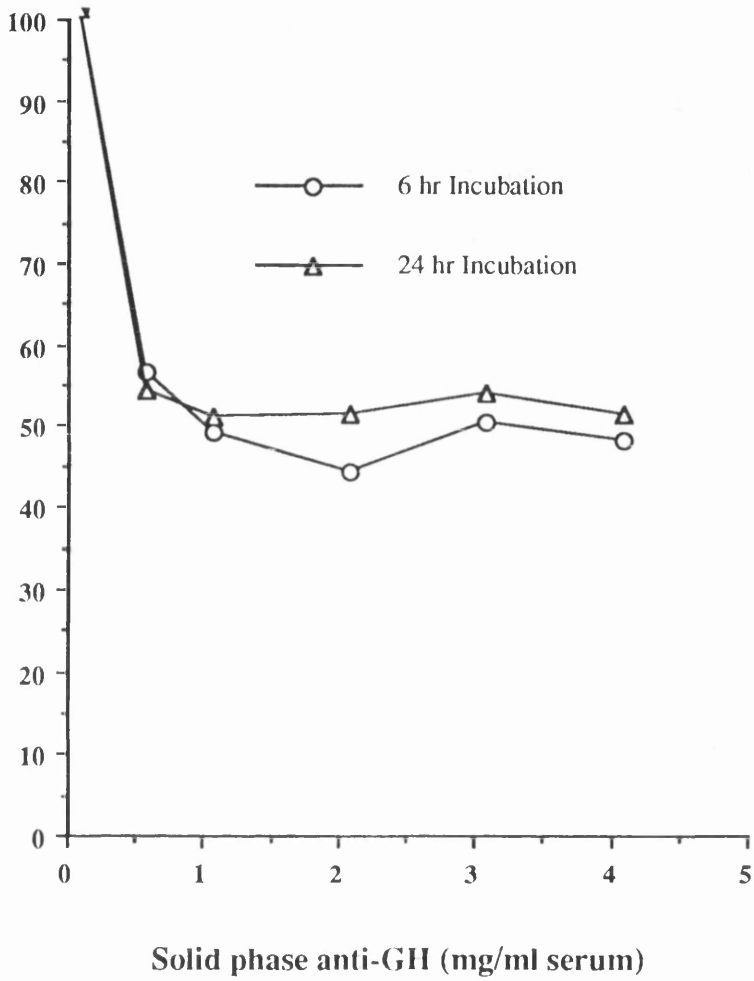

Figure 3.10 Percentage I^{125} -growth hormone immunoextracted from human serum.

Physiological pools were obtained from 4 volunteers who, after an overnight fast, were given 75g of glucose orally. Blood was withdrawn 30 – 45 minutes post ingestion of the glucose. The growth hormone concentration on all samples was <1.0 mU/l as measured by RIA. The effectiveness of suppression in each of these pools was compared by their utilisation as the standard matrix in IRMA dose response curves. Figure 3.11 shows that at growth hormone concentration above 6 mU/l the dose response curves are superimposable. The divergence at low concentration suggests that pools 3 and 4 probably contained higher concentrations of growth hormone. Pool 2 was selected for use in recovery experiments.

A recovery experiment was conducted using immunoextracted and physiologically suppressed growth hormone free human serum as the standard matrices. Three samples were each supplemented with 4.38, 8.75 and 17.5 mU/l of growth hormone. Each of the supplemented samples was assayed together with the appropriate basal samples. The calculated recoveries and the basal concentrations are shown in Table 3.5. Recoveries using the physiologically suppressed serum as standard matrix ranged from 83% to 113%, the average of the nine pools being 99.7%. The immunoextracted serum as standard matrix however over estimated the exogenous growth hormone added by on average 36%.

Physiologically suppressed serum was adopted as the optimal standard matrix.

3.4. ANALYTICAL VALIDATION

Prior to routine use the analytical validity of results produced by the IRMA was assessed by comparison with an established RIA, and by reference to the means of serum pools previously distributed by the U.K. External Quality Assessment Scheme (EQAS).

Stability and performance over a protracted period was assessed by routine computation of precision profiles, reference to internal quality control pools and

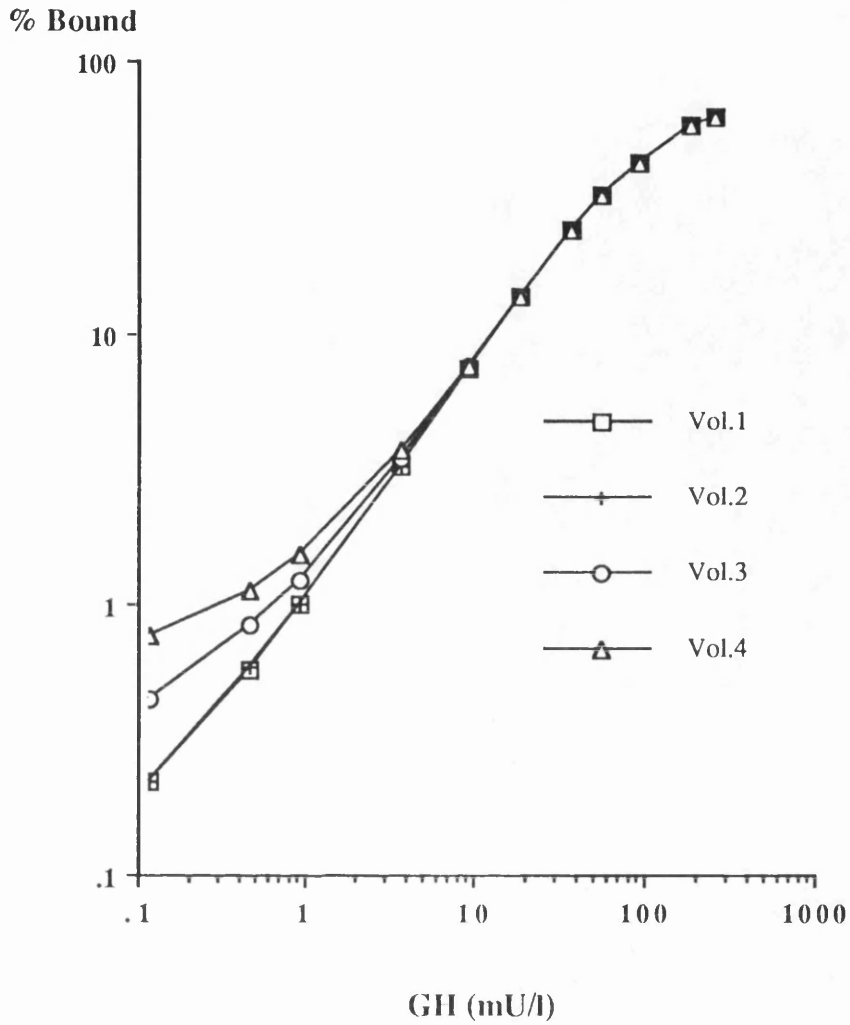

Figure 3.11 Dose response curve for growth hormone IRMA using glucose suppressed serum, from four normal volunteers, as standard matrix.

**Table 3.5 RECOVERY OF ADDED GROWTH HORMONE FROM THREE SERUM POOLS
AS A FUNCTION OF STANDARD MATRIX.**

	Pool	Basal conc. mU/l	+4.38 mU/l % Recovery	+8.75 mU/l % Recovery	+17.5 mU/l % Recovery
Glucose Suppressed Serum	P1	<0.5	88	83	93
	P2	3.85	106	97	113
	P3	9.9	109	110	98
Average % Recovery = 99.7					
Immunoextracted Serum	P1	<0.5	169	153	138
	P2	7.4	98	121	102
	P3	13.5	160	135	146
Average % Recovery = 135.8					

participation in EQAS.

The cross reactivity of structurally related hormones was also examined.

3.4.1. Comparison of IRMA with RIA

Three hundred samples were analysed in 3 assays including 10 samples distributed by EQAS. The correlation of results was good (correlation coefficient 0.9988), however the gradient of 0.863 without a significant intercept showed that the results by IRMA were 14% lower than those obtained by RIA. This was confirmed by comparison of the results on EQAS pools (Table 3.6). Relative to the all laboratory trimmed mean (ALTM) the RIA on average under estimates by 3.6% as compared to the IRMA's which under estimates by 18.4%.

This discrepancy was traced to a difference in the potency of the primary standards used in these assays. The IRMA was calibrated with IRP 66/217 standards while the RIA was calibrated using the U.K. 7 working standard commonly used by EQAS participants.

When U.K. 7 was used as the primary standard in both assays no systematic difference in results of EQAS pools was seen (Table 3.6). The potency difference between these standards was drawn to the attention of EQAS and at the time of writing is under investigation.

3.4.2. Internal Quality Control

a) Intra-assay precision.

Intra-assay precision was monitored by the computation of precision profiles using the WHO data reduction program. All duplicate estimations within an assay batch are used, the relative error (CV) being plotted against dose. A typical precision profile is shown in Figure 3.12. A coefficient of variation of less than 10% over the range 1–250 mU/l is achieved, and at the clinically important concentration of 20 mU/l a CV of <2% is observed. Within assay sensitivity as

**Table 3.6 COMPARISON OF GROWTH HORMONE CONCENTRATIONS IN EQAS
 POOLS:RIA VERSUS IRMA**

ALTM mU/l	RIA mU/l (U.K.7)	%ALTM	IRMA mU/l (66/217)	%ALTM	IRMA mU/l (U.K.7)	%ALTM
<0.5	<0.5	---	0.3	---	<0.2	---
24.3	23.2	96	19.8	82	26.1	107
45.8	44.0	96	38.3	84	46.8	102
21.6	20.5	95	17.4	81	21.1	98
38.9	38.5	99	33.3	86	39.1	101
8.9	8.7	98	7.2	81	8.8	99
3.3	2.9	88	2.4	73	2.7	82
10.3	9.7	94	8.1	79	10.2	99
18.4	18.6	101	15.8	86	20.0	109
5.9	6.0	102	5.0	85	6.3	107
	Avg. =	96%		Avg. =		Avg. =
						100%
						82%

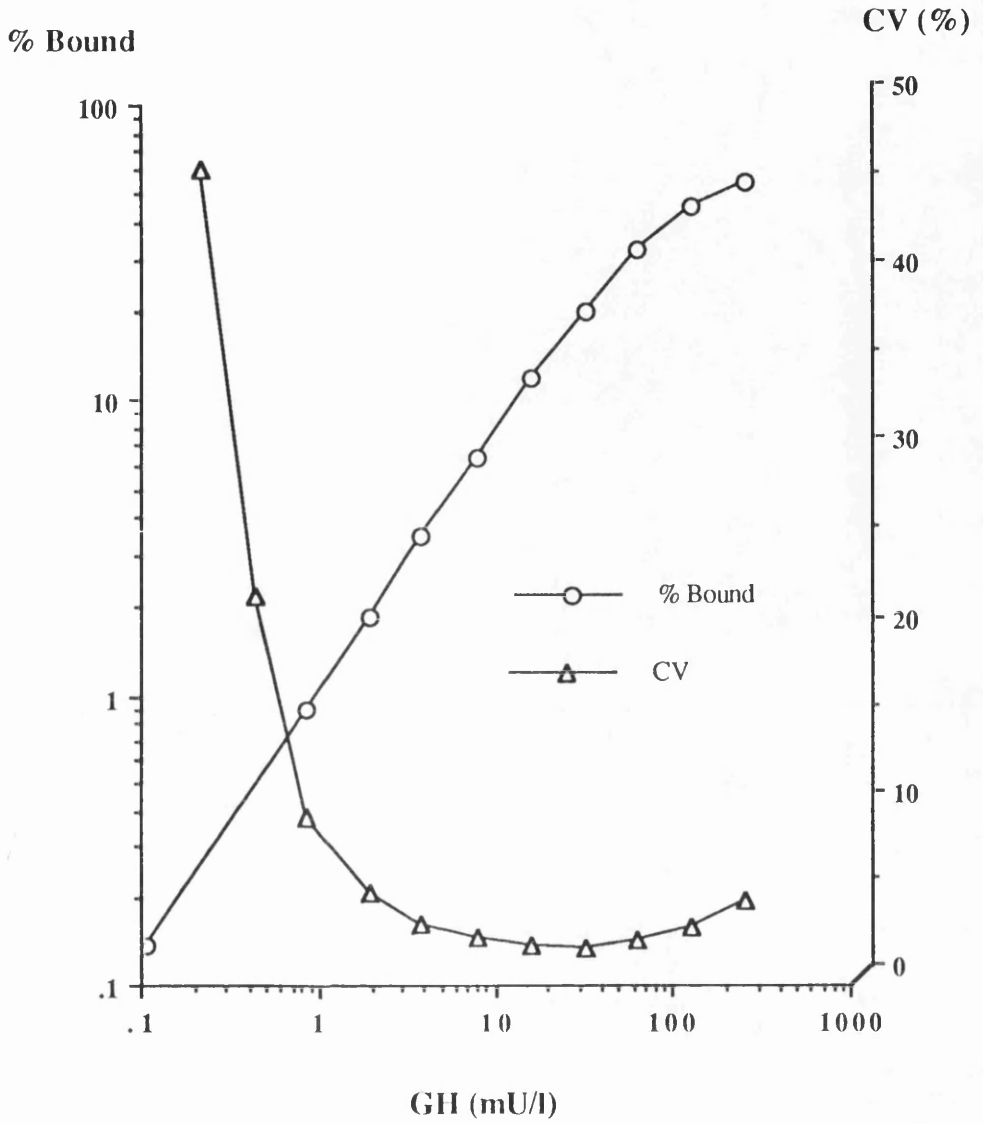

Figure 3.12 Within assay precision profile of optimised growth hormone IRMA.

defined by the dose at 22% CV (McConway *et al*, 1989) is 0.5 mU/l.

b) Inter assay precision.

Four pools of GH supplemented human serum are assayed in all batches. Figure 3.13 summarises the data derived from these pools on a monthly basis. A period of 11 months is shown. Mean pool concentrations over this extended period are 2.9, 10.9, 20.1 and 39.9 mU/l with respective mean CV's of 14.4, 8.7, 6.9 and 6.3%.

3.4.3. External Quality Assessment

External quality assessment data over the same extended period is shown in Figure 3.14. Percentage bias from the ALTM and the percentage variability of that bias are cumulative statistics calculated for each distribution based on the previous six months data. The introduction of the U.K. 8 working standard caused a shift in bias which is reflected initially as increasing variability of the bias.

Three months following the introduction of U.K. 8 standard a shift in bias of -30% on internal QC pools was noted. This was confirmed by retrospective analysis of EQAS pools. The U.K. 8 standard potency was therefore reassigned internally and the EQAS organisers informed. Other users of U.K. 8 have reported a similar problem.

3.4.4. Cross Reactivity Studies

There is considerable size and sequence homology in the primary structures of growth hormone , placental lactogen and prolactin most probably due to gene duplication (Wallis,1985). The potential for interference from physiological and pathological concentrations of placental lactogen and prolactin in the growth hormone IRMA was therefore assessed.

a) Prolactin

In the IRMA growth hormone standards were substituted with prolactin

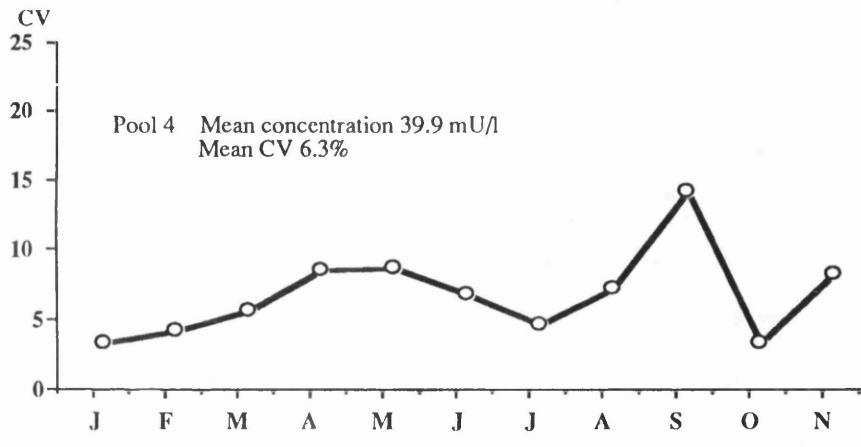
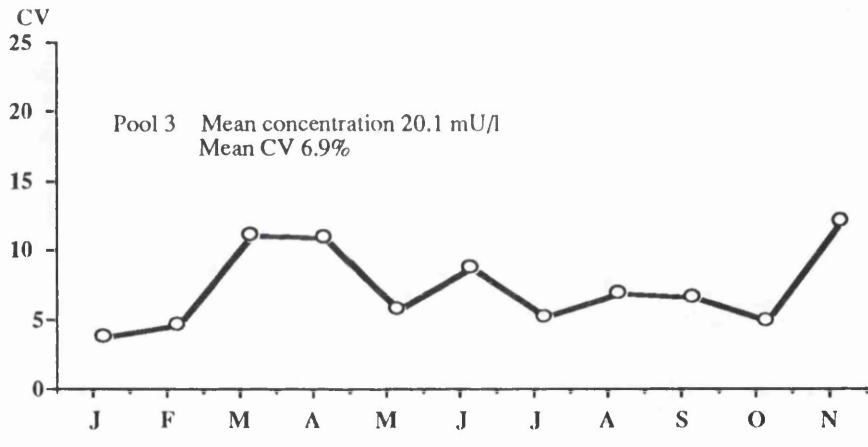
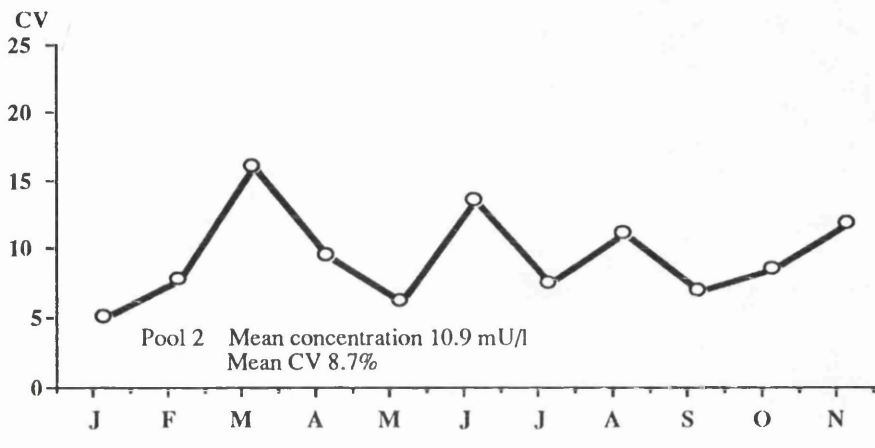
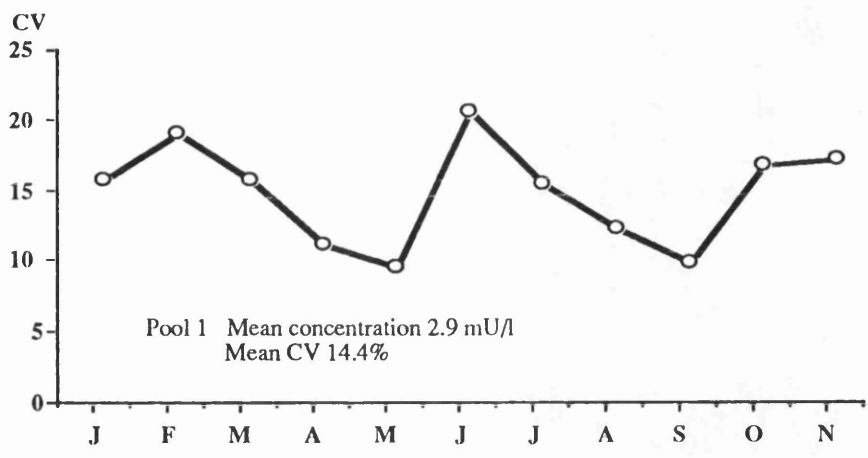
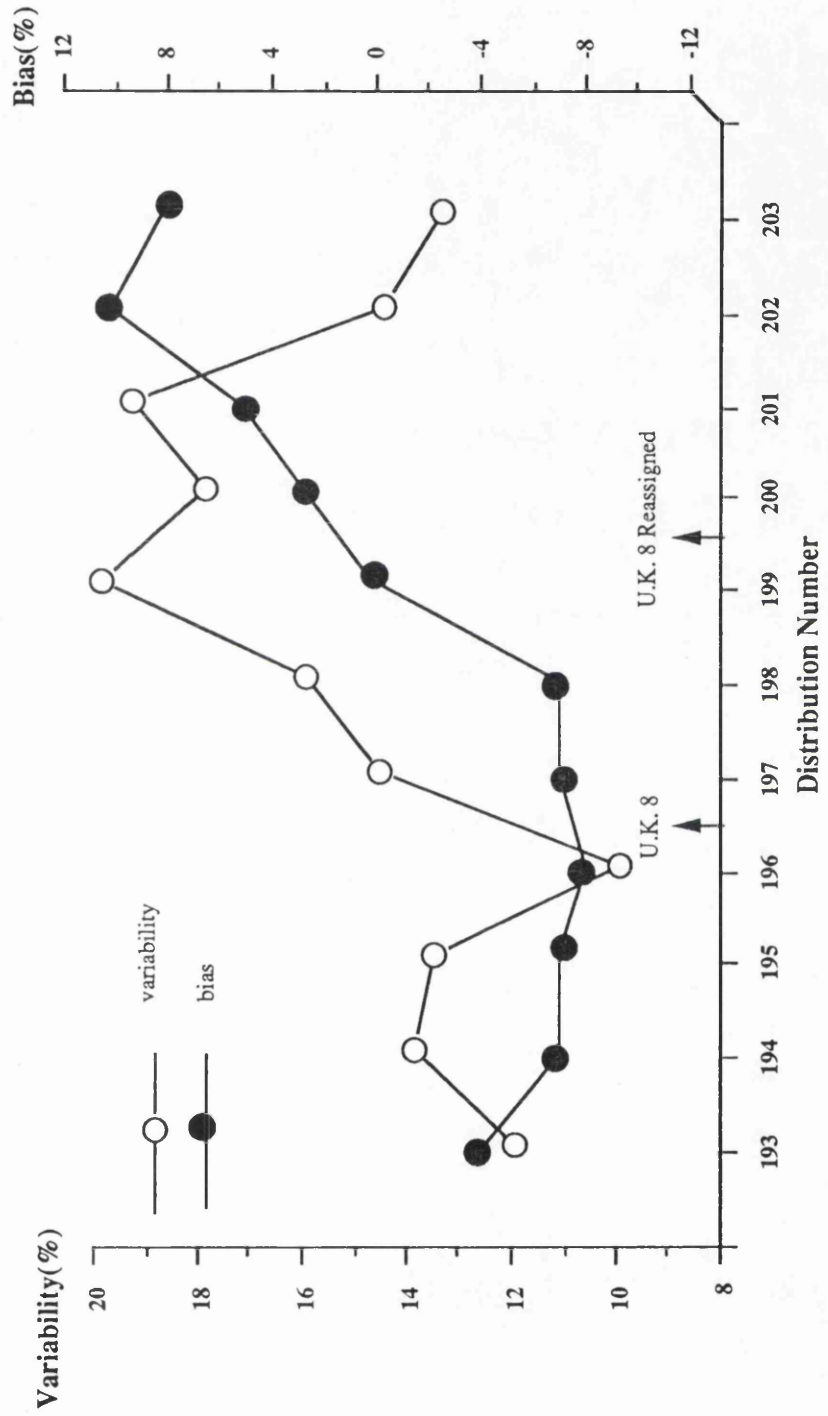

Figure 3.13 Inter-assay precision for optimised growth hormone IRMA.

Figure 3.14 External quality assessment of optimised growth hormone IRMA.



standards (0 –1980 µg/l). The highly purified prolactin was a gift from Dr. S.S. Lynch and is known to contain 0.015% growth hormone. Figure 3.15 shows the resultant dose response curve in comparison with the growth hormone dose response curve (0–119 µg/l). The percentage binding equivalent to 0.65 µg/l of growth hormone is obtained by 750 µg/l of prolactin. This translates to an observed 0.087% cross reaction with prolactin (0.072% after subtraction of known growth hormone contamination).

Since growth hormone contamination of prolactin standards can be a major problem and cross reaction in an IRMA is not necessarily additive, recovery experiments on samples from hyperprolactinaemic patients were conducted. Five samples with prolactin concentrations ranging from 1000–34000 mU/l were each supplemented with 14.8 mU/l of growth hormone. Growth hormone concentrations in basal and supplemented samples were measured and recovery of exogenous growth hormone calculated (Table 3.7). Quantitative recovery was obtained for all but the specimen with the highest prolactin concentration.

b) Placental lactogen

The same experiments as described above were performed using placental lactogen (1U/g UCB Bioproducts, Belgium) in place of prolactin. Standards were prepared covering the range 0–50000 µg/l. Comparison of standard curves is shown in Figure 3.15 from which cross reactivity is calculated to be 4.7%. Recovery experiments were conducted in samples from patients in the third trimester of pregnancy who were assumed to have elevated placental lactogen concentrations. Recovery data is shown in Table 3.8 and reveals a complete inability to measure added growth hormone.

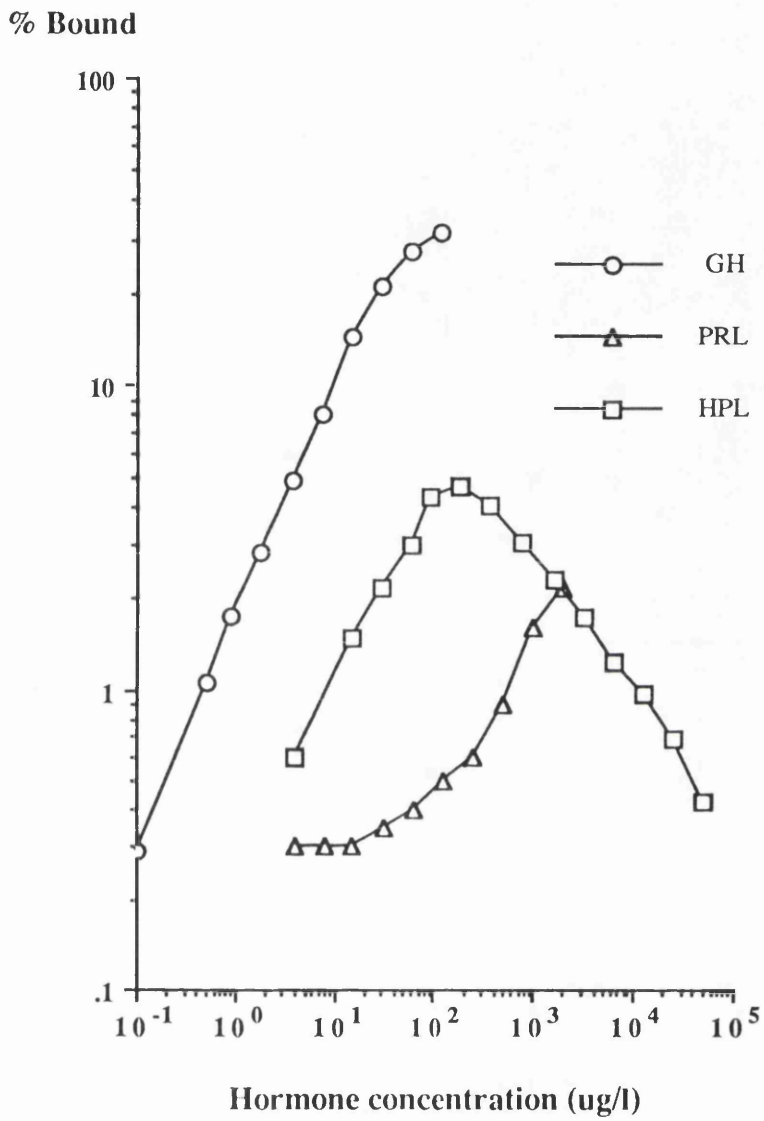

Figure 3.15 Assessment of PRL and HPL cross-reactivity in the growth hormone IRMA.

**Table 3.7 RECOVERY OF EXOGENOUS GROWTH HORMONE FROM SERUM IN
THE PRESENCE OF ELEVATED PROLACTIN CONCENTRATIONS**

Basal PRL concentration(mU/l)	Basal GH concentration(mU/l)	Basal + 14.8 mU/l GH	%Recovery
1000	8.4	23.4	101
2000	0.2	14.2	96
9600	<0.3	14.8	100
10500	<0.3	14.5	98
34000	<0.3	12.5	84

Table 3.8 RECOVERY OF EXOGENOUS GROWTH HORMONE FROM SERUM IN THE PRESENCE OF ELEVATED HPL CONCENTRATIONS.

Basal GH concentration (mU/l)	Basal + 14.8 mU/l	% Recovery
0.9	1.1	0.01
1.8	2.2	0.30
2.1	2.5	0.20
1.2	1.3	<0.01
1.1	1.4	0.02

3.5.

CLINICAL VALIDATION

Observations on basal blood samples are of little clinical value since growth hormone concentrations are affected by stress and show a circadian rhythm. It is common clinical practice to use dynamic tests of growth hormone suppression or stimulation as aids to diagnosis. Therefore, in assessing the clinical validity of the IRMA dynamic tests were examined.

3.5.1. Suppression Tests

The suppression test of choice in the diagnosis of acromegaly is the GTT, during which blood samples are withdrawn before the administration of 75 g of glucose and then at 30 minute intervals post glucose for two hours. Figure 3.16 shows the results of growth hormone estimations from the GTT's of three patient groups.

Group one consisted of 13 subjects, 9 female, 4 male, with a mean age of 45.6 years (range 19 – 62), with some clinical features of acromegaly who after investigation were considered not to have acromegaly. The mean basal concentration was 2.75 mU/l falling to a nadir of 0.56 mU/l at 60 minutes post glucose.

The second group, of 8 subjects, presented with clinical features of acromegaly and after investigation had the diagnosis confirmed and were subsequently treated by pituitary surgery. There were 4 male and 4 female subjects with a mean age of 48.8 years. Individual data is shown for each subject. Basal concentrations ranged from 11 – 185 mU/l and all subjects showed a lack of suppression of growth hormone concentration throughout the GTT.

Group three consisted of 10 subjects, 6 male and 4 female, with a mean age of 48.8 years (range 41 – 63), previously treated for acromegaly by pituitary surgery and/or irradiation in whom there was still clinical evidence of active disease. The mean basal growth hormone concentration was 9.3 mU/l which failed

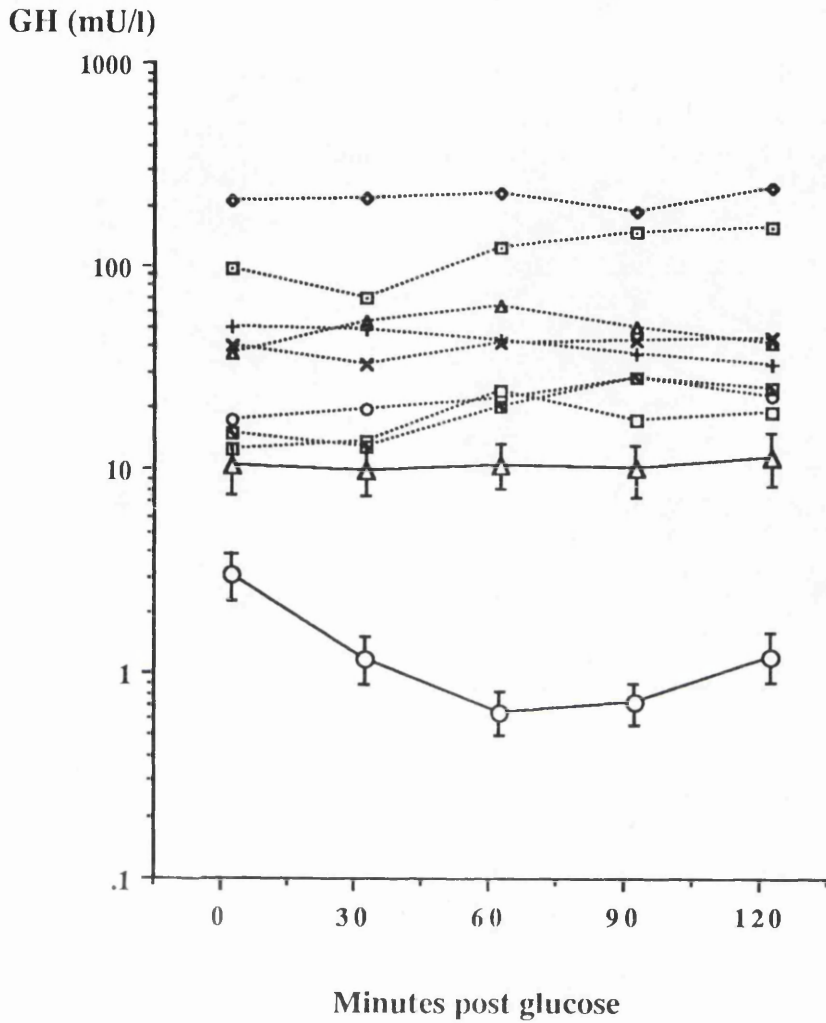

Figure 3.16 Clinical validation of optimised growth hormone IRMA: glucose tolerance tests.

○—○ = Group 1 ± SEM : - - - - - = Group 2 (individual patients) :
 Δ—Δ = Group 3 ± SEM .

to suppress at any time during the GTT.

3.5.2. Stimulation Tests.

In patients suspected of growth hormone deficiency stimulation tests are used to assess growth hormone reserve. The non-invasive exercise test is frequently used as a primary screen, a response to >20 mU/l excluding growth hormone deficiency. An inadequate response however requires further investigation most commonly in the form of an insulin tolerance test or less frequently the clonidine stimulation test.

i) Exercise test.

Figure 3.17 shows growth hormone concentrations from two groups of subjects before and 30 minutes following vigorous exercise. Group one consisted of 10 subjects, 6 male and 4 female with a mean age of 14.3 (range 11–18),with clinical features of growth hormone deficiency and in whom the diagnosis was subsequently confirmed. All subjects in this group showed a blunted or absent response to the stress of exercise. The 10 subjects in group two, 5 male and 5 female, mean age 13.4 years (range 12 – 14) while presenting with some clinical features of growth hormone deficiency showed a rise in growth hormone concentration to levels >20 mU/l and were therefore not further investigated.

ii) Insulin tolerance test

The data from three groups of subjects subjected to an insulin tolerance test are shown in Figure 3.18. Samples were withdrawn prior to the intravenous administration of 0.15 U/Kg insulin and then at 30, 45, 60, 90 and 120 minutes post insulin.

Group one consisted of 18 subjects, 13 female and 5 male, with a mean age of 33.6 (range 10 – 75) who were being investigated either for growth hormone deficiency or hypopituitarism but who were considered to have adequate growth hormone reserve. The mean basal concentration was 2.9 mU/l rising to a peak of

GH (mU/l)

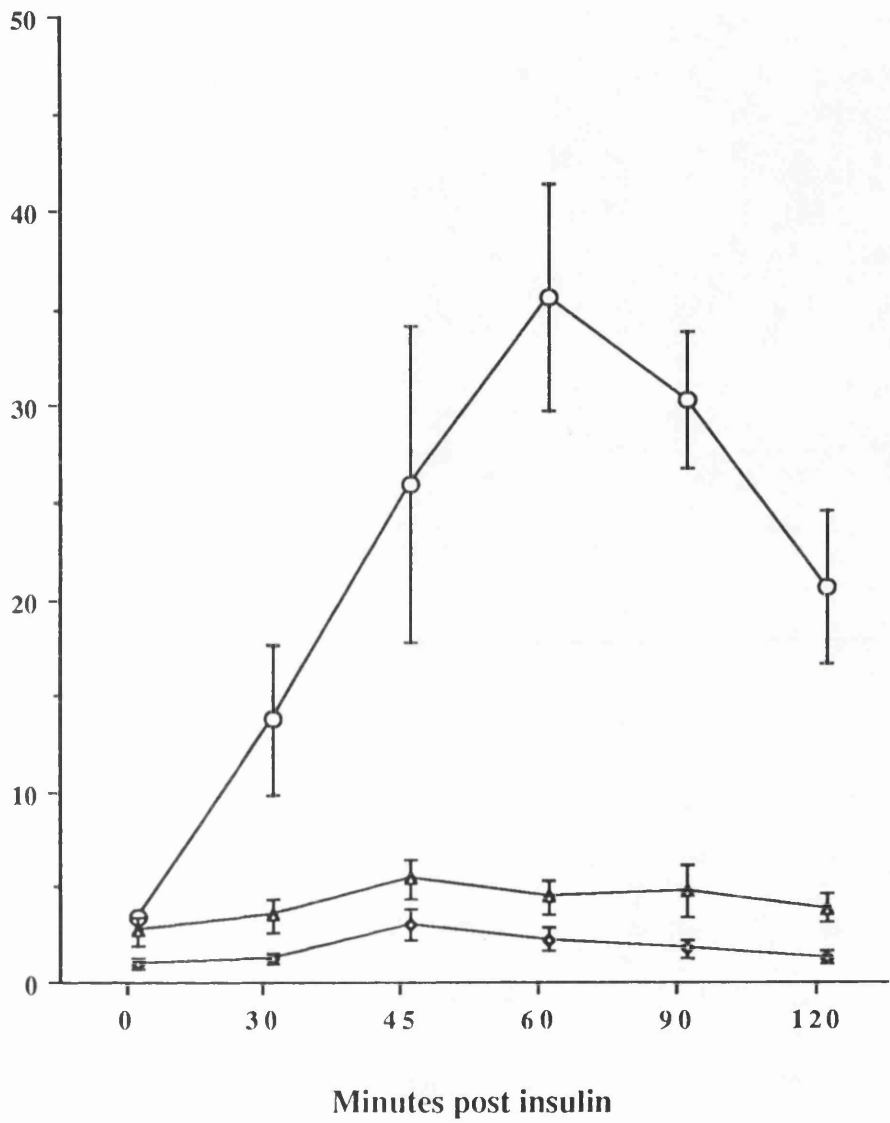

Figure 3.18 Clinical validation of optimised growth hormone IRMA:insulin tolerance tests.

○—○ = Group 1: △—△ = Group 2: ◇—◇ = Group 3.

± SEM

35 mU/l 60 minutes post insulin.

The second group consisted of 10 subjects, 4 female and 6 male, with a mean age of 39.9 years (range 16 – 75) who were investigated for hypopituitarism and in whom the diagnosis was subsequently confirmed. The mean basal growth hormone concentration in this group was 0.4 mU/l rising to 2.4 mU/l at 45 minutes post insulin. Adequate hypoglycaemia was demonstrated (glucose <2.2 mmol/l) at some point during the test.

Group three were subjects in whom a diagnosis of isolated growth hormone deficiency was established. This group consisted of 11 subjects, 5 male and 6 female, with a mean age of 12.8 years (range 6 – 19). The mean basal concentration was 2.1 mU/l rising to 4.9 mU/l at 45 minutes post insulin. Adequate hypoglycaemia was demonstrated at some point during each test.

iii) Clonidine stimulation test

The data from two groups of subjects subjected to a clonidine stimulation test are shown in Figure 3.19. Samples were withdrawn prior to the oral administration of 4 µg/Kg clonidine and then at 30 minute intervals for 120 minutes.

Group one is comparable to group one as described for the ITT. This group consisted of 13 subjects, 8 male and 5 female, with a mean age of 10.4 years (range 4 – 16). The mean basal concentration was 3.9 mU/l rising to a peak of 37 mU/l 60 minutes post clonidine.

The second group of ten subjects, (7 male and 3 female), with a mean age of 13.1 years (range 7 – 18) was a group of growth hormone deficient children. The mean basal concentration was 2.5 mU/l rising to a peak of 5.6 mU/l 90 minutes post clonidine.

GH (mU/l)

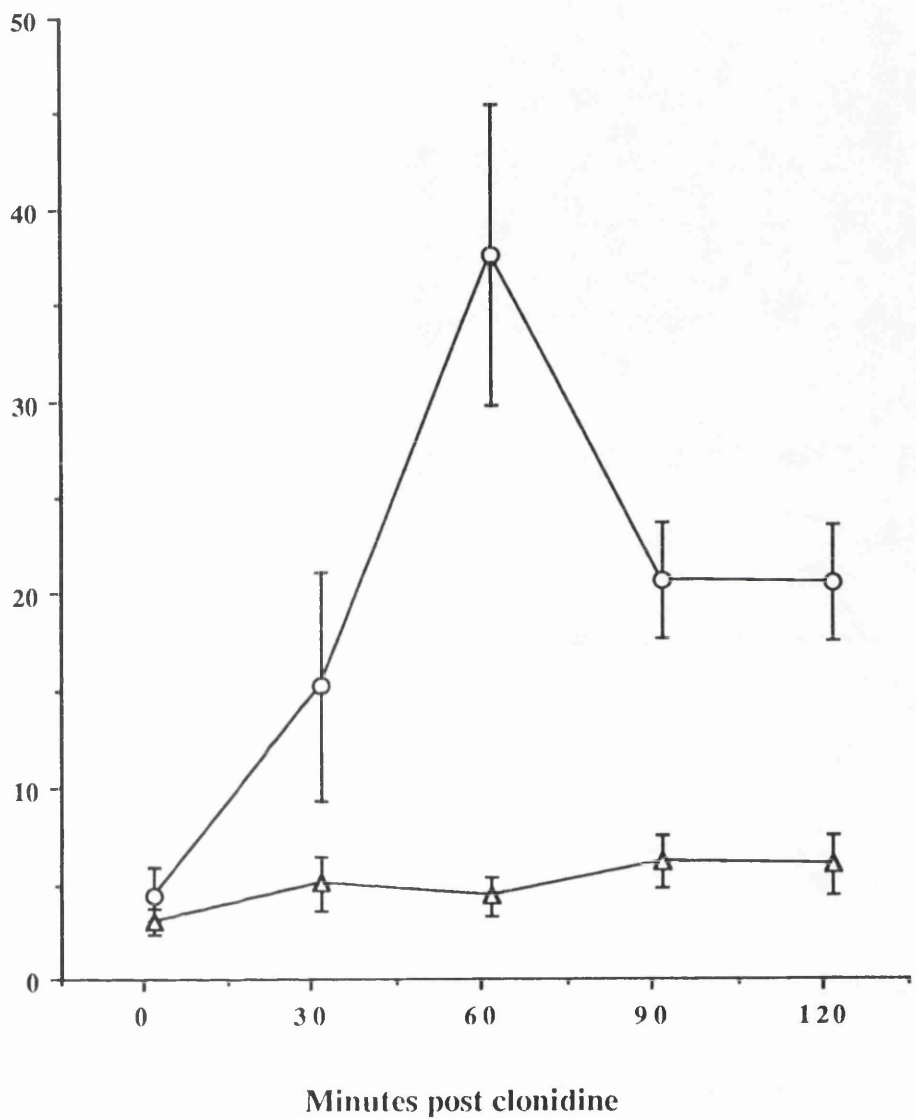

Figure 3.19 Clinical validation of optimised growth hormone IRMA: clonidine stimulation test.

O—O = Group 1; Δ — Δ = Group 2

\pm SEM

A monoclonal antibody to human growth hormone has been produced and successfully utilised in a two-site immunoradiometric assay. The assay has a wide working range (0.4–200 mU/l), is both precise and accurate, and can be completed within a working day. In a clinical context the IRMA gives the same discrimination as the RIA it supersedes.

The cross reaction studies with prolactin and placental lactogen illustrate a significant difference between RIA and IRMA. In RIA's cross reactive material will always give an additive effect while in IRMA's, since the specificity and relative affinity for the antigen of two antibodies has to be taken into account, under-recovery is more likely. The only apparent disadvantage of the IRMA is the inability to measure growth hormone during pregnancy. There is also evidence to suggest that growth hormone concentration may be under-estimated in samples that have prolactin concentrations in excess of 30000 mU/l. This interference from prolactin should not give rise to clinical misclassification.

Human growth hormone is a particularly good immunogen. This is due to the lack of homology in the structure of growth hormone between species (Wallis, 1985). The response of the immunised mice to growth hormone and favourable fusion conditions led to the generation of secreting hybridomas in 98.8% of the seeded wells. This is not a particularly desirable situation since the number of wells containing multiple hybridoma colonies will be large, leading to subsequent problems in cloning out a hybrid cell line with the desired properties. The pressure of time when performing screening assays is also magnified when such large numbers have to be processed and consequently detailed investigation of all potentially useful cell lines is not practicable.

Attempts to immunoextract growth hormone from serum proved to be disappointing. The inability to remove more than 50% of exogenous I¹²⁵GH from serum (Figure 3.10) may be explained by the existence of recently described

growth hormone binding proteins (Bauman, 1988).

This growth hormone assay has been in routine use in the Clinical Biochemistry Department at Glasgow Royal Infirmary for over a year and has proved to be a significant improvement on the RIA which it replaced.

CHAPTER 4

PARATHYROID HORMONE : THE PRODUCTION OF A MONOCLONAL ANTIBODY AND ITS APPLICATION TO AN IMMUNORADIOMETRIC ASSAY

4.1.1. Structure of Parathyroid Hormone

Parathyroid hormone is a single chain polypeptide consisting of 84 amino acid residues (Figure 4.1) having a molecular weight of 9425 daltons. It has no intra-chain disulphide bridges.

Parathyroid hormone has not been crystallised and therefore its tertiary structure is not known. Indications as to its three dimensional structure have been derived from hydrodynamic studies (Cohn *et al*, 1974), dark-field electron microscopy (Fiskin *et al*, 1977), and optical measurements (Cohn & MacGregor, 1981; Brewer *et al*, 1975; Edelhoch & Lippoldt, 1969). The results of these studies together with predictive formulas (Chou & Fasman, 1974^a : Chou & Fasman, 1974^b; Fasman *et al*, 1976 : Chou & Fasman, 1977) have produced a physical model consisting of two domains connected by a short stalk, the biologically active amino-terminal region occupying one domain and the carboxy-terminal region the other. Residues 30–40 are thought to constitute the connecting stalk because of the ease with which enzymes cleave parathyroid hormone in this portion of the hormone (Fiskin *et al*, 1977).

4.1.2. Biosynthesis of Parathyroid Hormone

The biosynthesis of parathyroid hormone takes place in the chief cells of the parathyroid glands.

In humans there is a single parathyroid hormone gene, containing two introns (non-coding regions), located on the short arm of chromosome 11 (Naylor *et al*, 1983; Kronenburg *et al*, 1986). The primary messenger RNA translation product, pre-preparathyroid hormone, undergoes a two step proteolytic cleavage to yield first preparathyroid hormone and then the native hormone. Preparathyroid hormone has a six amino acid extension to the N-terminus of the native molecule

Figure 4.1 The Primary Structure of Preproparathyroid Hormone

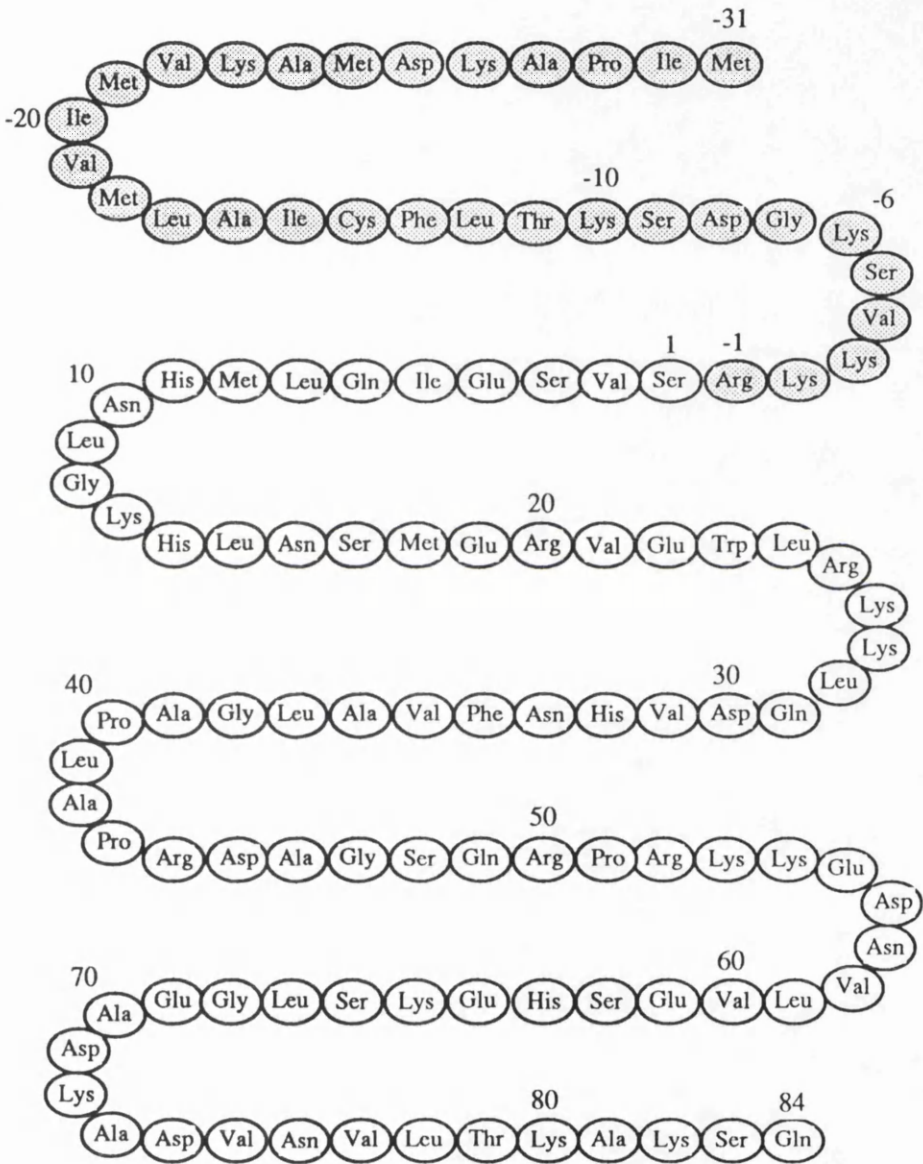

and pre–proparathyroid hormone has a further extension of 25 amino acids (Figure 4.1). The respective molecular weights of these precursors are 10200 and 13000 daltons (Cohn & MacGregor,1981). The pre–proparathyroid extension is thought to be a signal peptide facilitating the binding of the ribosome to the endoplasmic reticulum and the transport of parathyroid hormone into the cisternal space. The proparathyroid hormone extension probably facilitates transport within the cisternal space from the rough endoplasmic reticulum to the Golgi apparatus at which point it is removed (Cohn & MacGregor,1981). Some parathyroid hormone is stored in secretory granules until released into the circulation. However, mature secretory granules are scarce in the parathyroid gland, immature vesicles being more abundant. This has led to the suggestion that a proportion of the parathyroid hormone may be transported directly to the periphery of the cell without being packaged into granules (MacGregor et al, 1975).

Pulse chase experiments have shown that pre–proparathyroid hormone has a half–life of <1 minute and the half–time for the conversion of proparathyroid hormone to parathyroid hormone is approximately 10 minutes.

Figure 4.2 shows a diagrammatic representation of parathyroid hormone biosynthesis.

4.1.3. Factors Controlling Parathyroid Hormone Concentrations.

The principal factor controlling parathyroid hormone secretion is the concentration of ionised calcium in the blood (Patt & Luckardt, 1942: Sherwood et al 1968), there being an inverse relationship. This relationship is non linear; as the ionised calcium concentration falls below the physiological set point of 1.3 mmol/l so the rate of secretion of parathyroid hormone rises exponentially (Mayer & Hurst, 1978).

The assumption that the synthesis of parathyroid hormone increases when calcium ion concentration is low and secretion is high appears not to be the case. It

Figure 4.2 Synthesis and Secretion of Parathyroid Hormone in the Parathyroid Cell

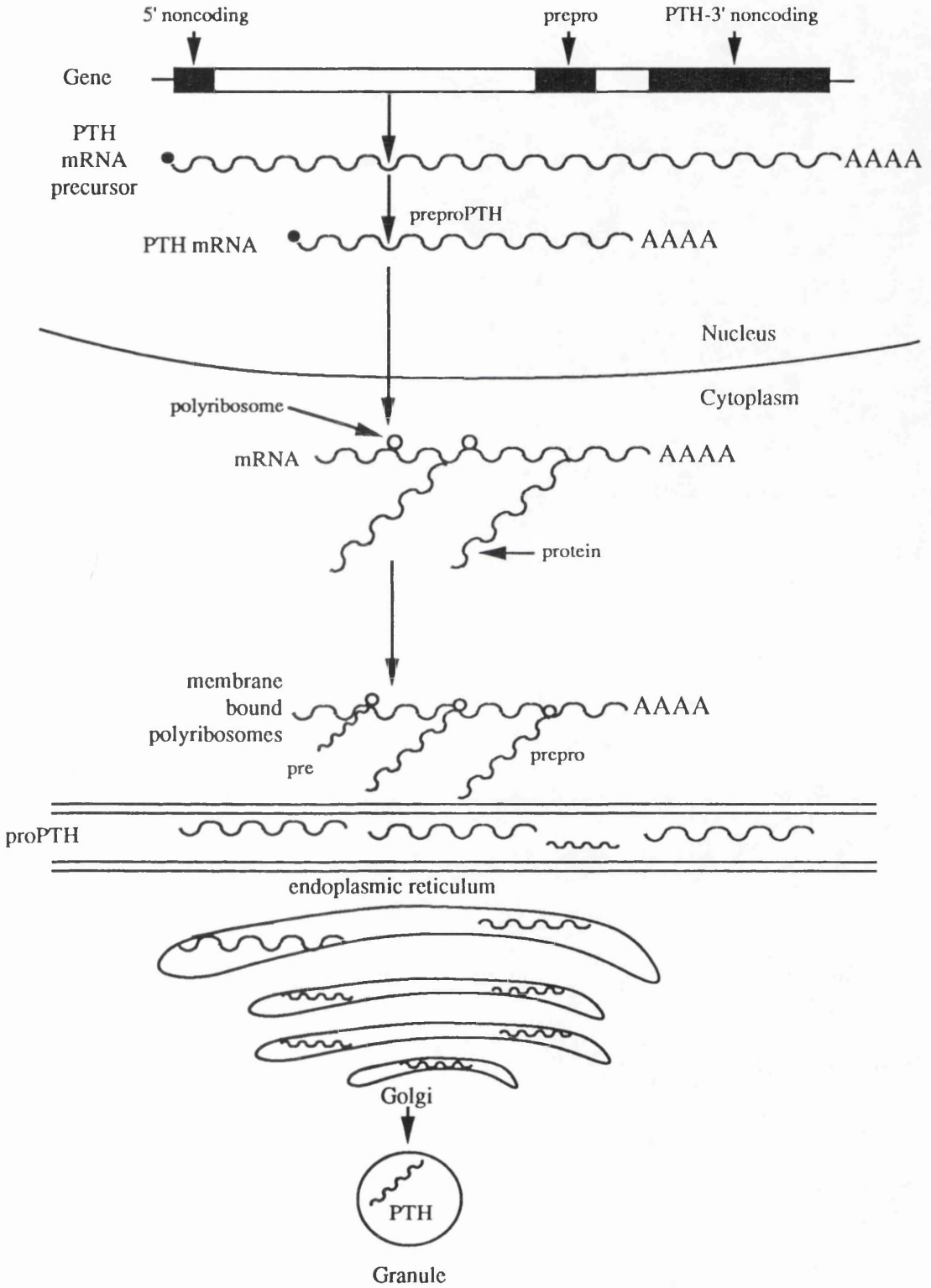

has been found that the rate of synthesis and turnover of parathyroid hormone is the same regardless of calcium status. The experiments of Morrissey and Cohn (1979) and Chu et al (1973) indicate that calcium affects hormone production through control of intracellular degradation, not synthesis.

Several other factors have been reported to affect parathyroid hormone synthesis and or secretion, notably magnesium (Buckle et al 1968; Targovnik et al 1971), cyclic adenosine monophosphate (cAMP)(Abe & Sherwood, 1972) and catecholamines (Williams et al, 1973; Kukregal et al 1976). Calcitonin at pathological concentrations causes release of parathyroid hormone (Fischer et al, 1971; Sherwood & Abe, 1972) but there is currently no clear evidence of a physiological control mechanism. The role of vitamin D metabolites remains unclear.

4.1.4. Circulating Fragments of Parathyroid Hormone.

In 1968, Berson and Yalow reported that parathyroid hormone in peripheral human plasma was heterogeneous. This heterogeneity is now universally acknowledged.

The intact, biologically active hormone has a circulating half-life of approximately 10 minutes and represents only about 10% of the immunoreactivity detected in peripheral plasma. Amino-terminal fragments of the hormone, also with a short half-life and possibly biologically active, may represent 5–10% of the circulating immunoreactivity. Carboxy-terminal fragments of the peptide constitute approximately 80% of the immunoreactivity in peripheral human plasma. Carboxy-terminal fragments are biologically inactive and have a long circulating half-life. Inactive mid-region fragments may also be present in the circulation (Roos et al, 1981; Marx et al, 1981).

The source of these fragments and their biological significance remains a controversial issue.

4.1.5. Physiological Effects of Parathyroid Hormone.

The parathyroid glands, through the integrated actions of parathyroid hormone, are primarily responsible for the regulation of mineral homeostasis. This control results from the direct effects of parathyroid hormone on calcium and phosphorus metabolism in the kidney and in bone.

a) Effects on kidney.

The principal actions of parathyroid hormone on kidney are two-fold. Firstly to stimulate the renal excretion of phosphate and to enhance the renal tubular reabsorption of calcium. These effects are thought to be mediated by adenyl cyclase stimulating the formation of cAMP from ATP. Secondly to stimulate the 1α hydroxylation of 25-hydroxycholecalciferol thus indirectly controlling intestinal absorption of calcium and phosphorus.

b) Effects on bone.

The actions of parathyroid hormone on bone are complex and not yet fully understood. The response of bone to parathyroid hormone is biphasic. The immediate action is largely that of bone mineral mobilisation elevating blood levels of calcium and phosphorus. These effects may be seen within minutes following hormone administration. A second or slower action of parathyroid hormone is its effect upon bone cell activity. Parathyroid hormone is believed to increase the size and number of osteoclasts (bone-resorbing cells), thus upsetting the balance between osteoblasts (bone-forming cells) and osteoclasts leading to an increased rate of bone remodelling. The net effect is usually a net negative skeletal balance of calcium and phosphorus. Also associated with prolonged bone resorption is an increased release of lysosomal enzymes so that there is a mobilisation of bone matrix which results in increased blood levels of hydroxyproline.

4.1.6. Plasma Parathyroid Hormone Estimations in Clinical Practice.

The measurement of the concentration of plasma immunoreactive parathyroid hormone concentration is of value in the investigation of patients with hypocalcaemia or hypercalcaemia. The relative clinical value of an assay for parathyroid hormone will depend upon its specificity and the circulating forms of immunoreactive parathyroid hormone present (see section 4.1.7.)

Hypocalcaemia may result from a primary defect in calcium metabolism which cannot be corrected by compensatory increases in parathyroid hormone secretion (osteomalacia, chronic renal failure). Alternatively, the primary defect may be impaired synthesis and or secretion of parathyroid hormone (hypoparathyroidism) or target organ resistance to parathyroid hormone due to defective hormone–receptor interaction (pseudohypoparathyroidism).

Hypercalcaemia may also be the result of either parathyroid hormone dependent or parathyroid hormone independent causes. In the former, hypercalcaemia is accompanied by elevated plasma parathyroid hormone concentration (hyperparathyroidism) whereas in the latter the plasma parathyroid hormone concentration is suppressed (malignant hypercalcaemia, hypervitaminosis D, etc.).

It is increasingly being recognised that the interpretation of a plasma parathyroid hormone concentration result may be complemented by knowledge of plasma and or urinary cyclic AMP status. This is especially important in the investigation of pseudohypoparathyroidism and in situations where there are high concentrations of immunoreactive but biologically inactive fragments of parathyroid hormone.

For a detailed review of this topic the reader is referred to "Calcium Homeostasis:Hypercalcemia and Hypocalcemia"(Mundy,1989).

4.1.7 History of the Development of Parathyroid Hormone Assays.

Assays for the measurement of PTH in plasma can be divided into three broad groups:–

- 1) Bioassays
- 2) Radioimmunoassays
- 3) Immunometric assays

Many of the original bioassays of parathyroid hormone are too insensitive for measurements of plasma concentrations. However, the cytochemical bioassay based on determination of glucose-6-phosphate dehydrogenase (G6PD) activity in the distal convoluted tubules of the guinea pig kidney is reported to be able to distinguish hormonal activity in plasma from normal, hypoparathyroid and hyperparathyroid subjects. (Goltzman et al, 1980; Fenton et al, 1978). This is a particularly sensitive assay however, it is also cumbersome and time consuming and therefore not generally available. An alternative bioassay is that based on the use of guanyl nucleotide–amplified renal adenylate cyclase which has been reported for human renal cortical plasma membranes (Nissenson et al, 1981; Niepel et al, 1983). The principle of the procedure is the biological activation by human parathyroid hormone of adenylate cyclase in membrane–enriched homogenised renal cortical tissue; the adenylate is quantitated by radioimmunoassay of the generated cAMP. This assay is not as sensitive as the cytochemical bioassay but may be more practical.

Radioimmunoassay of parathyroid hormone was first described by Berson *et al* 1963. A plethora of assays have subsequently been described. The narrow specificity of antisera has been a hinderance to the development of clinically meaningful assays because of the existence of significant concentrations of circulating parathyroid hormone fragments. The radioimmunoassays described to–date can be divided in four broad groups, those using:–

1) N-terminal specific antisera

(Silverman & Yalow,1973; Arnaud et al,1974)

2) C-terminal specific antisera

(Reiss & Canterbury,1968; Hawker et al, 1984)

3) Mid-molecule specific antisera

(Marx et al,1981; Roos et al,1981)

4) Immunoextraction followed by RIA with one of the above

(Lindall et al,1983)

N-terminal specific assays, despite theoretical advantages, have proved to be disappointing in their discrimination between normal and primary hyperparathyroid subjects, primarily because of poor sensitivity. However N-terminal assays are useful for evaluating the parathyroid status of patients with chronic or acute renal failure (Hawker et al, 1983) and for evaluating venous catheterisation samples in diagnosing patients with hypercalcaemia of malignancy (Hawker et al, 1983; Martin et al,1980).

C-terminal and mid-molecule parathyroid hormone assays have provided a clearer clinical discrimination between normal and abnormal parathyroid function, the C-terminal assays being slightly better than the mid-molecule assay. (Arnaud et al, 1974; Martin et al ,1980; Hawker et al, 1983). These assays are of limited value in patients with hypercalcaemia of malignancy and impaired renal function because of the accumulation of C-terminal fragments.

The method of Lindall et al (1983), a two step procedure, involves the extraction and concentration of serum PTH moieties using solid-phase bound anti-N-terminal antibody. The immunoextract is then assayed by RIA using a mid-molecule antibody. This method was the first to measure intact 1-84 parathyroid hormone and was reported to give clear distinction between normal subjects and subjects with proven primary hyperparathyroidism.

The first immunometric assay for parathyroid hormone was that of Addison

et al (1971). This assay and that of Papapoulos et al (1980) are of the type described by Miles and Hales (1968^b) utilising a single radiolabelled antibody and offer no advantage in terms of specificity over the region specific radioimmunoassays. Blind et al (1987) described a two-site assay using polyclonal antibodies, one a partially purified goat anti-N-terminal coupled to cellulose particles, the other a rabbit anti-C-terminal antibody which was indirectly radiolabelled following sandwich formation by incubation with a C-terminal radiolabelled fragment (Tyr⁵²-hPTH⁵³⁻⁸⁴). While offering some improvement in specificity for the intact 1-84 molecule the assay design limits sensitivity.

Nussbaum et al (1987) utilised two goat immunoaffinity purified polyclonal antibodies. The N-terminally directed antibody being radiolabelled and the C-terminal antibody immobilised by adsorption onto polystyrene beads. This assay forms the basis of the commercially available Allegro™ kit, and is both sensitive and specific for intact 1-84 parathyroid hormone.

The two-site principle has also been applied by Brown et al (1987) in a chemiluminometric assay. The assay depends upon the formation of an immune complex of acridinium ester-labelled sheep polyclonal anti N-terminal parathyroid hormone, intact parathyroid hormone, and particulate solid phase monoclonal mouse anti mid-molecule parathyroid hormone. This assay is commercially available in the form of the Ciba-Corning Magic-Lite™ kit.

Another two-site assay measuring intact parathyroid hormone is that supplied by Incstar. This assay is identical in design to the Allegro™ system. Clinical utility has been found to be improved in comparison to radioimmunoassays (Ratcliffe et al, 1989).

The strategy adopted in this project reflects the primary aim of producing a two-site immunoradiometric assay for the measurement of intact 1–84 parathyroid hormone. Pre-determination of antibody specificity was assured by utilising synthetic parathyroid hormone fragments as immunogens. This approach attempts to maximise the chances of producing the required complimentary pair of monoclonal antibodies.

4.2.1 Immunisations and Assessment of Response

Synthetic peptides from both the N and C terminal fragments of parathyroid hormone were used as immunogens. The 1–34 and 53–84 fragments were used alone and also conjugated to bovine albumin. Conjugation was by the glutaraldehyde method described by Orth, 1979. Commercially prepared conjugates of the N-terminal undecapeptide and the C-terminal nanopeptide were also tried. These peptides were conjugated to KLH (keyhole limpet haemocyanin) via a bis-diazotised tolidine linkage.

Each of these preparations was used to immunise three strains of mouse and two strains of rat. Primary subcutaneous immunisation was followed by two booster doses at three week intervals. Test bleeds were taken three weeks following the final dose. Table 4.1 summarises the results of the screening assay in which serial dilutions of animal sera were incubated for 18 hours with either I^{125} labelled PTH1–34 or PTH53–84. The bound fraction was separated by incubation with either Sepharose coupled sheep anti-rat polyclonal antibody or sheep anti-mouse polyclonal antibody.

The albumin conjugates were also used to immunise sheep. A response was elicited but these antibodies were found to be of low avidity.

The response of DA rats to the 1–34PTH fragment was particularly good, all animals showing a high titre response. These DA rats were used in a series of

Table 4.1

SUMMARY OF RESPONSES TO IMMUNISATION

	Mice			Rats		Sheep
	Balb/c	CBA	Balb/c x NZB	Lou	DA	
PTH 1-34	-	-	-	-	+++	N/A
PTH 53-84	-	-	-	-	-	N/A
Alb-PTH 1-34	-	-	-	-	-	+/-
Alb-PTH 53-84	-	-	-	-	-	+
KLH-PTH 1-11	-	-	-	-	-	N/A
KLH-PTH 75-84	-	-	-	-	-	N/A

hybridisation experiments.

4.2.2 Hybridisation Experiments

Four days prior to each of the hybridisation experiments the selected rat was given an intra-jugular injection via the pectoral muscle of 50µg 1-34PTH. Splenectomies on average provided spleens weighing 1g.

Two groups of hybridisation experiments were conducted, using either the rat myeloma cell line YO (a gift from Dr. C. Milstein) as fusion partner or the mouse myeloma cell line X63.Ag8.653. Myeloma cells were maintained in logarithmic growth for at least one week prior to the hybridisation experiment and on the day of the experiment had an estimated viability of >90%. The ratio of spleen cells to myeloma cells for fusion was 1:1. Three separate fusions were performed during each experiment, the products of each fusion being dispensed, in 2x HAT medium, into the wells of five 96 x 0.2ml microtitre plates. Mouse peritoneal macrophages, harvested the day prior to the hybridisation experiments, were used as feeder cells at a density of 5×10^3 cells/well.

4.2.3 Assessment of Hybridisation Experiments

In the two hybridisation experiments using the YO myeloma cell line hybrid growth was poor and no stable colonies were evident.

The three cross-species hybridisations, however, repeatedly generated growing hybrids in over 50% of wells. Supernatants were removed for testing ten days after fusions. The screening assay involved the incubation of 50µl of supernatants with I^{125} 1-34PTH for 18 hours followed by separation of the bound fraction with a Sepharose coupled polyclonal sheep anti-rat antibody. In total 39 secreting hybrids were found, five of which survived cloning. The antibodies from these cell lines were isotyped by immunodiffusion (Table 4.2).

Ascitic fluid containing antibody was generated by intraperitoneal injection

Table 4.2 ISOTYPES OF ANTI-PTH 1-34 MONOCLONAL ANTIBODIES

Antibody Code	Isotype
1D1	IgG2b
3B3	IgG2b
4G3	IgG2a
6E3	IgG2a
9E3	IgM

of 5–10 x10⁶ hybridoma cells, in 0.5ml of RPMI 1640, into pristane primed athymic (nude) mice. Taps of ascitic fluid were taken when there was evidence of abdominal distention. All five cell lines gave good yields.

Figure 4.3 shows the antibody titres of sequential taps from a mouse primed with the 6E3 cell line. Antibody titre increases as a function of tap number up to tap 4 and then declines. Taps 3 and 4 for each cell line were pooled and the immunoglobulin fraction extracted by n-octanoic acid precipitation (Chapter 2, section 2.2.1).

4.2.4 Assessment of Monoclonal Antibodies

The selection of the most appropriate of these monoclonal antibodies for use in an intact 1–84PTH IRMA was based primarily on their relative affinities for 1–84 PTH. Some attempt was also made to localise the binding sites of these antibodies.

Dilution/displacement experiments were conducted with equimolar concentrations of 1–10PTH, 1–34PTH, bovine 1–84PTH and human 1–84PTH. Table 4.3 summarises the results of these displacement studies. The 1D1 antibody is of low affinity. 9E3 does not recognise the intact 1–84PTH. The antibodies 3B3 and 6E3 are equivalent in their displacement of both 1–34PTH and 1–84PTH, and were therefore chosen for further study.

It is apparent from Table 4.1 that attempts to produce antibodies to the C-terminal fragment of PTH proved unsuccessful. However two potentially complimentary monoclonal antibodies were available from other centres for evaluation in conjunction with the 3B3 and 6E3 antibodies. The monoclonal antibody coded E10A10, supplied by Dr. S.J. Woodhead (Cardiff), is specific for an epitope in the region of 44–68PTH. Monoclonal antibody ESQ–1 produced in Edinburgh by Dr. K. James is specific for the 74–84 region of parathyroid hormone.

% Bound

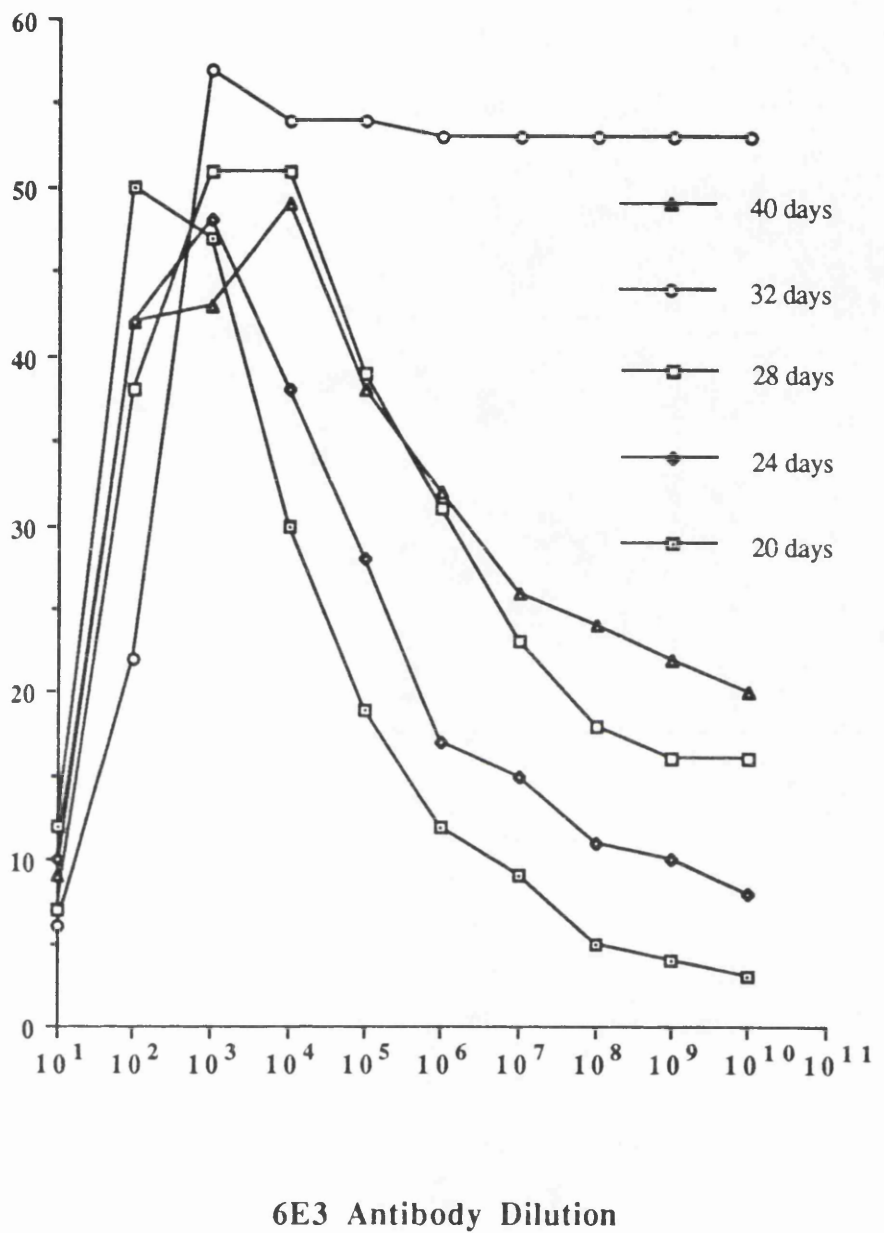

Figure 4.3 Antibody titres of sequential ascitic fluid taps.

Table 4.3 % INHIBITION OF I125 1-34 PTH BY EQUIMOLAR CONCENTRATIONS OF PTH AND PTH FRAGMENTS

Antibody Code	1-10 PTH	1-34 PTH	1-84 hPTH	1-84 bPTH
1D1	0	0	0	0
3B3	0	29	27	0
4G3	0	47	16	16
6E3	0	34	30	0
9E3	0	79	0	0

h = human b = bovine

4.3 DEVELOPMENT OF A TWO-SITE IMMUNORADIOMETRIC ASSAY

The selection of the best complimentary pair of antibodies required that each of the N-terminal antibodies be assessed in conjunction with each of the C-terminal antibodies, the utility of the combination being assessed with reference to signal to noise ratio.

Given that in plasma there is a significant excess of C-terminal fragments over intact 1-84PTH the optimum assay design should be to utilise the N-terminal antibodies coupled to a solid-phase to extract the intact 1-84PTH prior to incubation with a radiolabelled C-terminal antibody. Antibody combinations were therefore assessed using radiolabelled C-terminal antibodies and solid-phased N-terminal antibodies.

4.3.1 Radioiodination of Anti-PTH Monoclonal Antibodies

Radioiodination was by the lactoperoxidase method described in Chapter 2, section 2.2.4, using 20 µg of monoclonal antibody and 18.5 MBq of ¹²⁵Iodine. Post iodination purification was by gel filtration chromatography on a 60 x 1.6 cm column of Sepharose 6B. The elution buffer (buffer 3) was pumped at a flow rate of 10 ml/hour and 1 ml fractions were collected. The radioactivity of each fraction was counted for 10s. Iodination profiles are shown in Figure 4.4. Specific radioactivity of the monoclonal antibodies are calculated to be in the range 555-740 Bq/µg.

4.3.2 Preparation of Solid-Phase Anti-PTH Monoclonal Antibodies

For screening purposes the N-terminal monoclonal antibodies were adsorbed onto microtitre plates. Purified ascitic fluid preparations were diluted to a concentration of 200 µg/ml in TAPS buffer pH 8.6. Each of the antibodies was adsorbed onto the surface of a 0.2 ml x 96 well microtitre plate by dispensing 200 µl of antibody solution into each well and incubating at 37°C for 18 hours. The wells were then washed 6 times with TAPS buffer containing 0.5% BSA . 200 µl of

Counts/s
x1000

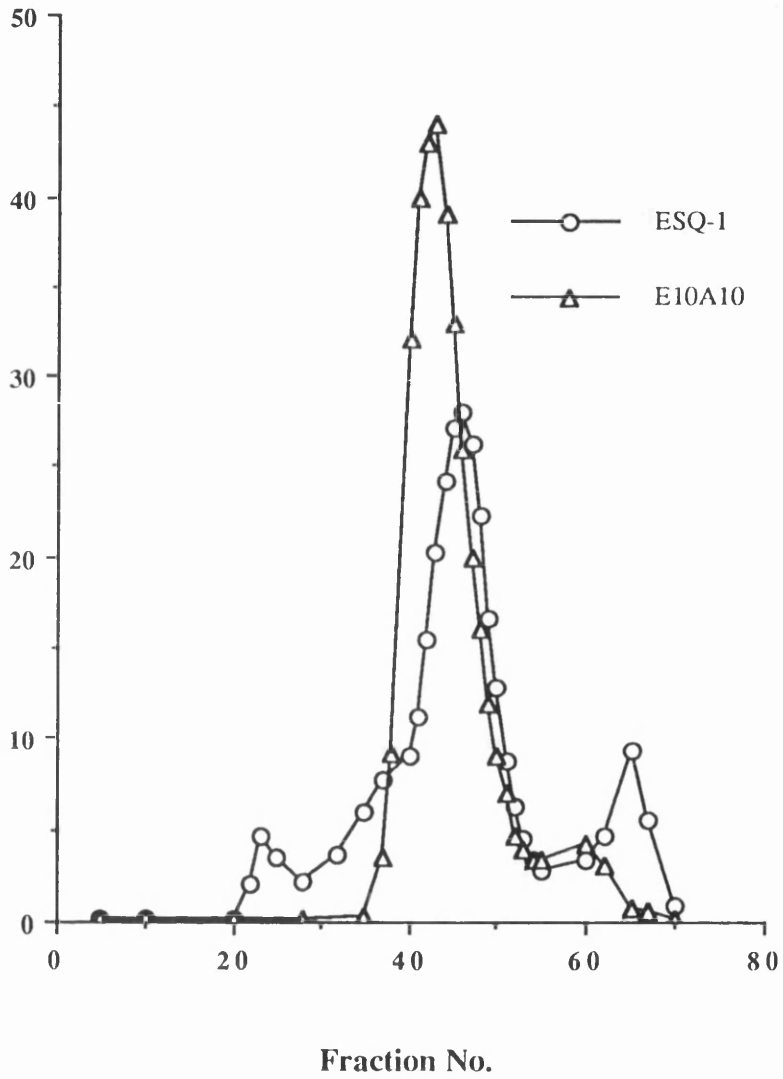

Figure 4.4 Radioiodination profiles of two C-terminal specific monoclonal antibodies.

wash buffer were incubated in the wells for 1 hour at 37°C. Wells were then subjected to 3 further wash cycles.

4.3.3 Selection of a Complimentary Pair of Antibodies

Parathyroid hormone standards based on IRP 79/500 were prepared at concentrations of 125 pmol/l and 250 pmol/l. Duplicate 100 µl aliquots of the standards were incubated for 18 hours at 4°C with each of the radiolabelled C-terminal antibodies (100 µl = 1 ng) in the wells of the two coated microtitre plates. Unbound radiolabelled antibody was then removed by washing the wells with 6 x 0.2 ml of Taps buffer, pH 8.6, containing 0.5% BSA. The bound radioactivity in each well was counted for 60 seconds. Results are shown in Table 4.4. The signal to noise ratios (binding at 250 pmol/l / binding at zero dose) suggest that ESQ-1 and 3B3 would be the best combination. The generated signal over the lower dose range, the clinically relevant range, however is poor. Siddle, 1985, suggested that the affinity of the radiolabelled antibody has a more significant effect on the achievable sensitivity than does the affinity of the solid-phased antibody. The roles of these antibodies were therefore reversed, N-terminal antibody 3B3 was radiolabelled (lactoperoxidase method) and the C-terminal antibody ESQ-1 coupled to Sepharose CL-4B (see Chapter 2 section 2.2.3). Sepharose CL-4B was chosen as the solid-phase because of its increased capacity for the uptake of antibody. This was thought necessary to overcome the potential interference of circulating C-terminal fragments. A two stage assay was performed incubating standards at zero concentration and 250 pmol/l with radiolabelled N-terminal antibody (10⁵ cpm/100 µl = 1ng/tube) for 18 hours at ambient temperature. Solid-phased C-terminal antibody was added (1 mg Sepharose/tube) and incubated with shaking for a further 2 hours. Sepharose particles were then subjected to three centrifuge /wash cycles with 2 ml of saline containing 0.2% Tween-20. Bound radioactivity was counted for 60 seconds. Percentage radioactivity bound at zero dose was 0.5% while at 250

Table 4.4 RESULTS OF TEST FOR COMPLIMENTARY ANTIBODIES

Standard Concentration (pmol/l)	†3B3			†6E3		
0	0.16	0.11	0.14	0.11		
125	0.53	1.02	0.35	0.44		
250	1.98	9.53	0.92	3.07		
	E10A10*	ESQ-1*	E10A10*	ESQ-1*		ESQ-1*

Figures are % radiolabelled antibody bound.

* Denotes radiolabelled antibody.

† Antibody coated microtitre plates.

pmol/l was 37.5%, a 75 fold change. The capacity of the solid-phase antibody was further evaluated by the production of two dose response curves covering the range 0–250 pmol/l into one of which a 200 molar excess of C-terminal fragment (53–84PTH) was added. The excess C-terminal fragment had no effect on the dose response curve.

4.3.4 Optimisation of Assay Conditions

The basic conditions described in the previous section were used as a reference. Studies were performed varying buffer pH and protein content, radiolabelled antibody mass and specific activity, solid-phased antibody mass, incubation times and solid-phase wash conditions. The effects of varying conditions were assessed arbitrarily on the basis of improvements in signal/noise ratio and more specifically the precision profile and the concentration at which a hook effect occurred. In the interests of brevity data from the many individual experiments is excluded. The overall optimised conditions are as follows :–

- a) Buffer – 0.1M phosphate buffer pH 7.0, containing 0.05M EDTA, 0.9% NaCl, 1% protease free BSA, 1% rat serum, 0.2% Tween–20, 0.02% NaN₃ and 0.15% H₂O₂.
- b) I¹²⁵ Anti–PTH – specific activity 555–740 Bq/μg, adding 10⁵ cpm/tube in 0.1 ml assay buffer.
- c) Solid–phase Anti–PTH – 1 mg/tube in 0.1 ml assay buffer.
- d) Incubation period – 200 ul sample + label + solid–phase incubated with shaking for 22 hours at ambient temperature.
- e) Wash conditions – 4 x 2 ml of 0.9% NaCl containing 0.2% Tween–20 and 0.02% NaN₃.
- f) Standards – standards are prepared from dilutions of synthetic 1–84PTH (Peninsula) in bovine serum (SAPU). The reference preparation MRC 79/500 has a potency of 0.5 relative to the synthetic 1–84PTH.

Assay validation is divided into two broad groups, analytical validation and clinical validation.

4.4.1 Analytical Validation

a) Intra assay precision.

Figure 4.5 shows a typical dose response curve and a precision profile constructed from duplicate analysis of 100 patient samples in a single assay. The precision profile data gives an estimated sensitivity of 0.5 pmol/l (22% CV) and a range of 1.5–250 pmol/l with a CV of <10%.

b) Inter assay precision

Three pools of PTH supplemented human serum are assayed in all batches. Table 4.5 summarises the data derived from these pools over a 3 month period. Pool means are 2.8, 12.6 and 18.4 pmol/l with respective CV's of 12.6, 8.3 and 9.6%.

c) Recovery of exogenous PTH

Ten patient samples were supplemented with 10 pmol/l of synthetic 1–84PTH. Each of the basal samples were assayed along with the supplemented samples. The basal concentrations ranged between 1.5 and 15.0 pmol/l (mean 6.9 pmol/l). Supplemented sample concentrations ranged between 12.0 and 25.0 pmol/l (mean 17.6 pmol/l). The mean recovery was 107% (range 98–110).

4.4.2 Clinical Validation

The concentration of PTH 1–84 was determined in plasma from 57 apparently healthy fasting adults. The mean value in "normal" subjects was 2.21 pmol/l. All subjects had detectable amounts of PTH 1–84 in their plasma. The reference range was estimated (2 SD) as 1.0 – 4.2 pmol/l.

Twenty eight subjects with either subsequently surgically proven primary hyperparathyroidism or presumptive hyperparathyroidism awaiting surgery had plasma 1–84 PTH concentrations ranging from 5.1 pmol/l to 100 pmol/l (Figure

% Bound

% CV

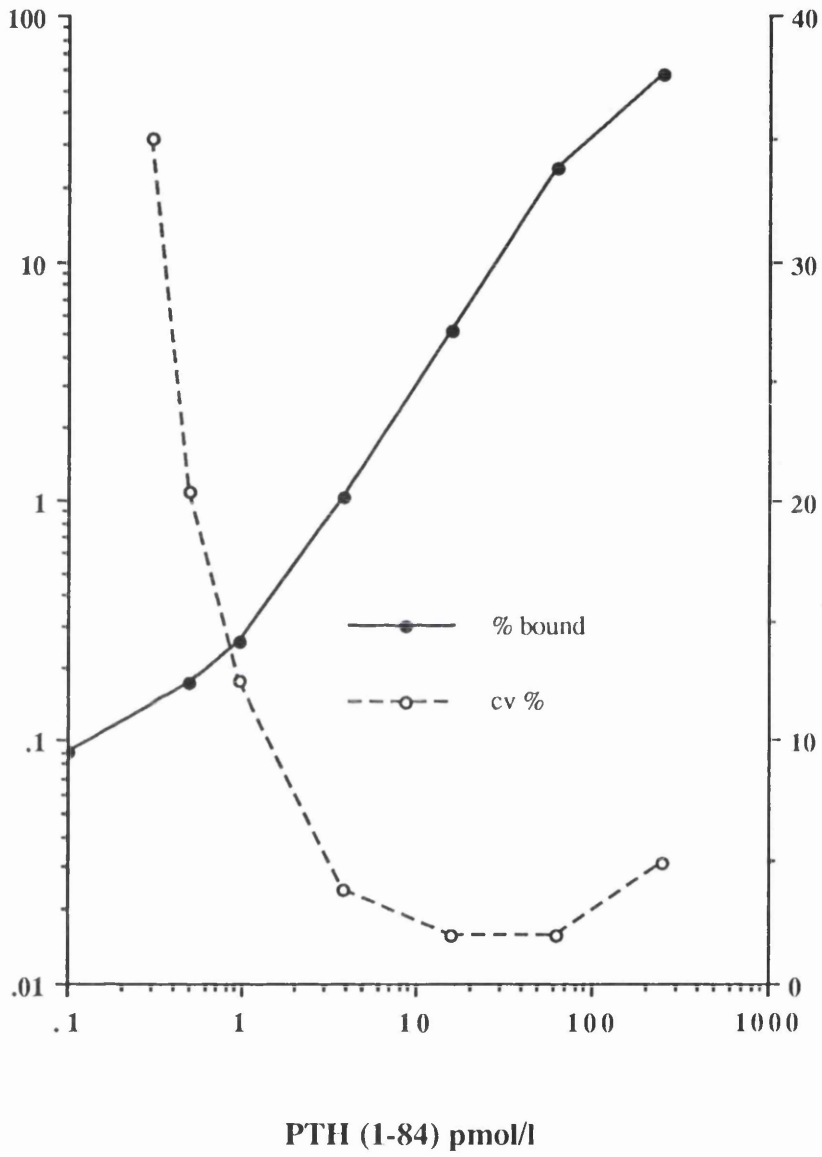

Figure 4.5 Dose response curve and within assay precision profile of optimised PTH IRMA.

**Table 4.5 INTER ASSAY PRECISION:PERFORMANCE
OVER A THREE MONTH PERIOD.**

<u>Month</u>		<u>Pool A</u>	<u>Pool B</u>	<u>Pool C</u>
Feb	Mean	2.9	13.0	18.7
	SD	0.5	1.1	1.7
	CV	16.9	8.8	9.1
	N	10	11	11
Mar	Mean	2.7	11.8	17.7
	SD	0.1	1.1	1.8
	CV	5.0	9.4	10.0
	N	11	11	11
Apr	Mean	2.9	12.9	18.9
	SD	0.5	0.9	1.9
	CV	15.8	6.6	9.8
	N	12	12	12

4.6).

Eighteen subjects with hypercalcaemia of malignancy were also evaluated. Fourteen of these subjects had undetectable concentrations of 1–84 PTH. Three of the four remaining patients with PTH concentrations between 0.4 and 0.9 pmol/l had some degree of renal impairment. The fourth patient with a PTH of 2.7 pmol/l was also found to have an elevated urinary cAMP concentration.

Samples from six cases of hypoparathyroidism secondary to radical neck surgery gave undetectable 1–84 PTH concentrations.

Figure 4.6 summarises the data from these clinical groups.

4.5

CONCLUSIONS

Monoclonal antibodies to human parathyroid hormone have been produced the specificity of which, to some degree, was pre-determined by the choice of immunogen (Logue et al,1986). The most appropriate of these antibodies has been utilised, in conjunction with a C-terminal specific monoclonal antibody, in a two-site immunoradiometric assay for intact 1–84 parathyroid hormone. This is the only intact 1–84 parathyroid hormone assay described to-date which utilises two monoclonal antibodies.

Parathyroid hormone is a poor immunogen , however the response in DA rats was excellent. There is evidence to suggest that the choice of species or strain for immunisation could be particularly important when attempting to produce antibodies to low molecular weight peptide hormones. Immune responsiveness to many soluble synthetic and natural protein antigens has been found to be genetically controlled. These immune response genes are linked to the major histocompatibility complex (MHC) of the mouse, the H-2 complex. Nussbaum et al (1985) concluded that the immune response to human 1–34 parathyroid hormone in mice is genetically controlled.

In view of the high serum titres seen in the DA rats, the number of secreting

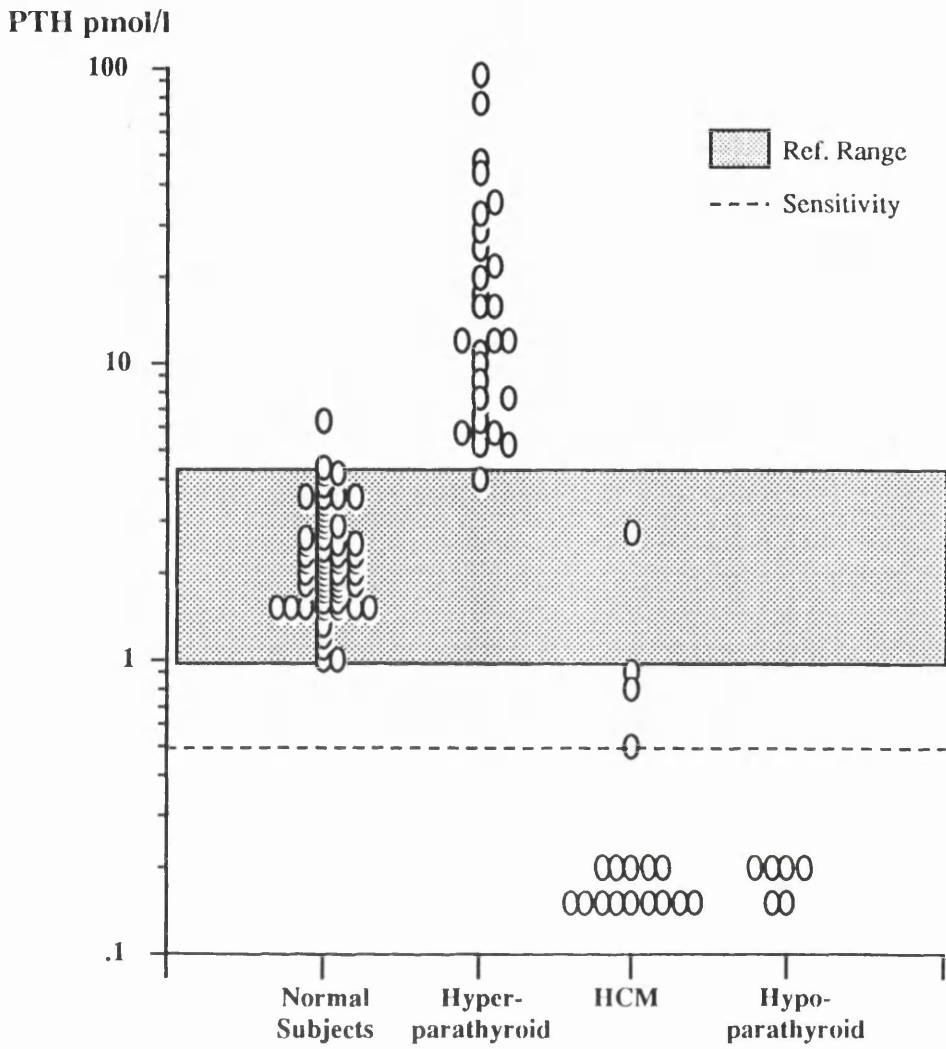

Figure 4.6 PTH concentrations in defined clinical groups

hybrids generated from each fusion was disappointing. If it can be assumed that the products of fusions reflect the state of immunisation of the spleen donor then the results generated would suggest that either the timing of the priming dose of immunogen was incorrect or that the immunogen was significantly altered as a consequence of intravenous injection.

The use of athymic mice for the generation of ascitic fluid proved particularly successful posing the question as to whether the response seen was a feature of the animal used or the cell line injected. These animals proved easy to handle and they survived well with minimum barrier conditions.

The data presented in Figure 4.3 has practical implications. The increase in titre as a function of tap number would suggest that the later taps (3+4) have a greater content of specific antibody and therefore will give a greater yield of usable material.

The difference between the radioiodination profiles of the ESQ-1 and E10A10 antibodies (Figure 4.4) can be explained by the fact that E10A10 is an n-octanoic acid purified preparation while ESQ-1 is purified by sodium sulphate precipitation. This data would suggest that n-octanoic acid is more efficient than sodium sulphate for this purpose.

The optimised assay has a wide working range, is sensitive, precise and quantitatively recovers exogenously added 1-84 parathyroid hormone. The detection limit is such that normocalcaemic individuals have detectable concentrations. The estimated reference range is in agreement with previously published data (Newman and Ashby, 1988). Initial clinical studies suggest that diagnostic utility is good, there being no overlap between those subjects with primary hyperparathyroidism and those with hypercalcaemia of malignancy (Logue et al, 1988). More recently this assay has been applied to a re-evaluation of parathyroid hormone physiology and pathophysiology (Van der Merwe et al, 1988 : Logue et al, 1989^a : Logue et al, 1989^b : Logue et al, 1990).

CHAPTER 5

ATRIAL NATRIURETIC FACTOR

Physiological experiments have repeatedly suggested the existence of natriuretic substances that increase the excretion of sodium from the kidney probably by inhibiting the reabsorption of sodium along the renal tubule (de Wardner et al, 1961; Bahlmann et al, 1967).

During the 1950's several research groups performing electron microscopic studies of the heart noticed multiple electron-dense granules within the cytoplasm of atrial muscle cells (Kisch, 1956; Bompiani et al, 1959). In 1976 Marie et al studied the degree of granulation of these atrial cardiocytes in rats maintained on various water and sodium intakes. They showed a significantly greater number of granules in the right atrium as compared to the left and that the degree of granulation altered as a consequence of thirst and salt loading. Structural similarities between atrial granules and the granules that exist in endocrine tissues were first noted by de Bold (1978) leading to the speculation that atrial granules could contain a hormone. The same author also noted the changes in granularity as a function of sodium and water status (de Bold, 1979) and made the connection with his previous speculation. Subsequently he demonstrated that the injection into a rat of an extract of rat cardiac atria produced a dramatic diuresis and natriuresis (de Bold et al, 1981).

The search for the active component led to the independent isolation of several closely related peptides (Flynn et al, 1983; Atlas et al, 1984; Currie et al, 1984; Kangawa & Matsuo, 1984), all showing the same ring of 17 amino acids but with varying chain lengths. This has led to a confusing terminology relating to atrial peptides. In retrospect the peptide heterogeneity is probably artifactual and related to differing degrees of damage as a result of the variety of extraction techniques employed. Trippodo et al (1984) proposed that the differences may indicate the existence of a larger precursor molecule.

5.1.1 Nomenclature and Structure of Atrial Peptides

In 1987 a joint committee of the International Society of Hypertension, the American Heart Association and the World Health Organisation published recommendations on the nomenclature of atrial peptides (Dzau et al, 1987). This nomenclature will be used throughout this thesis.

It has now been established that the major active form of atrial natriuretic factor (ANF) released into and circulating in human plasma is a single chain 28 amino acid peptide (Miyata et al, 1987). This peptide has a molecular weight of 3080 daltons, and contains a disulphide bridge between residues 7 and 23 (residues 105 and 121 of proANF). The ring structure so formed is necessary for biological activity (Misano et al, 1984; Hirata et al, 1985). Cloning and sequencing of complimentary DNA has enabled the structure of the prohormone to be deduced (Oikawa et al, 1984; Seidman et al, 1984). Figure 5.1 shows the structure of the 151 amino acid peptide prepro-atrial natriuretic factor and Figure 5.2 shows the structural relationships of the various peptides described in the literature.

5.1.2 Biosynthesis of Atrial Natriuretic Factor

It is now generally accepted that the immediate stimulus to ANF release is the excitation of atrial stretch receptors by distention of the atrial wall, whether due to mechanical stretch (Ledsome, 1985), high perfusion pressure (Dietz, 1984), or acute volume expansion (Lang et al, 1985^a).

Prepro-ANF is encoded on chromosome 4 (Lewicki, 1986). The nucleotide sequence of the genomic DNA coding for prepro-ANF consists of three exons separated by two introns. The first exon encodes the signal peptide in addition to the first sixteen amino acids of pro-ANF. The second exon encodes the remainder of the pro-ANF molecule except the carboxy-terminal tyrosine, which is encoded by the third exon (Greenberg et al, 1984). Post-translational cleavage of the

Figure 5.1 Primary structure of prepro-atrial natriuretic factor

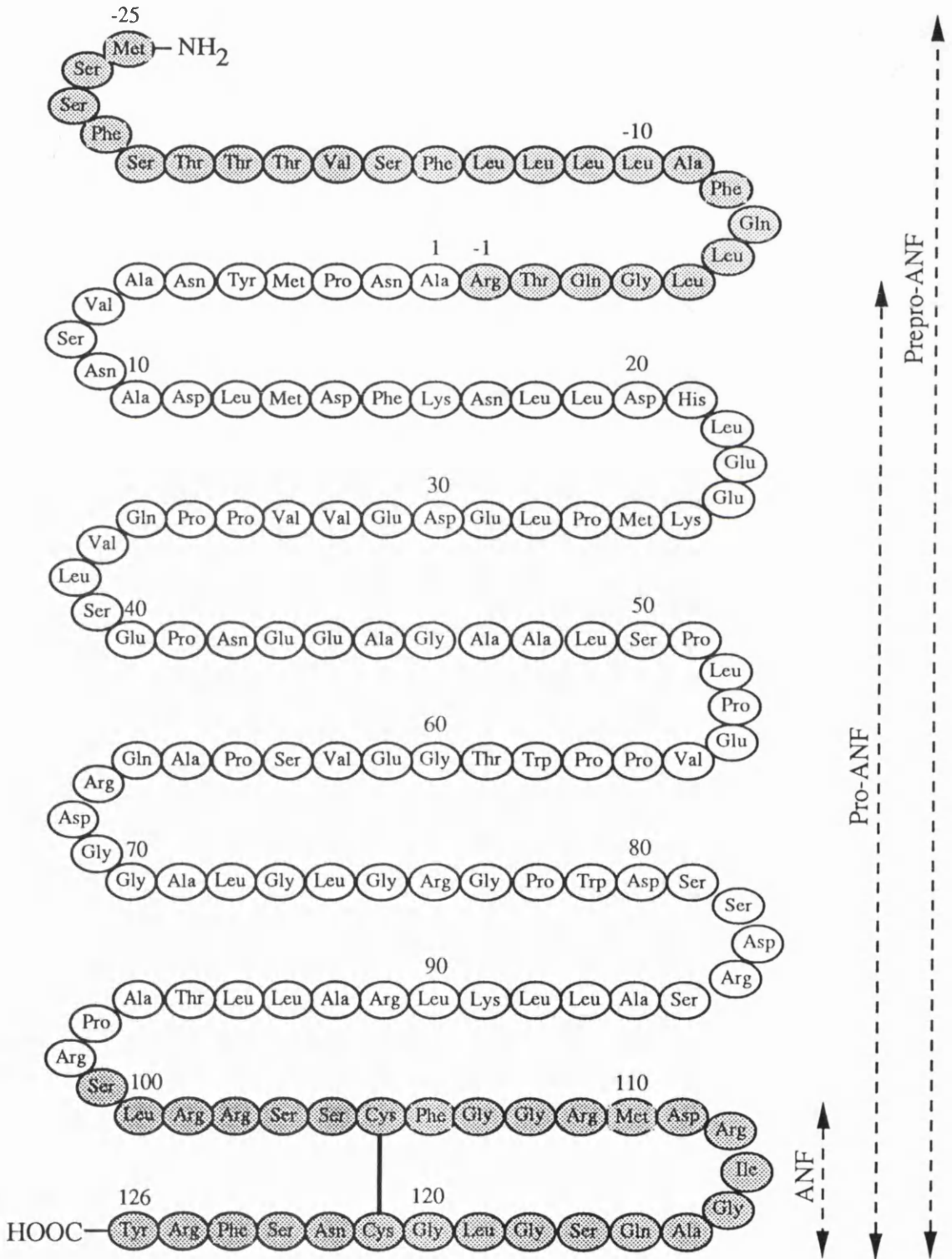

hydrophobic N-terminal 25 amino acid leader sequence or signal peptide generates a 126 amino acid prohormone, pro-ANF or ANF 1–126, which is stored in granules within the atrial myocyte. The C-terminal 28 amino acid peptide ANF is cleaved from the prohormone at the time of release into the circulation. It has a half-life in blood of approximately three minutes (Yandle et al, 1986^b). The N-terminal 98 amino acid fragment, ANF 1–98, is co-secreted (Michener et al, 1986); its biological function, if any, is unknown.

An anti-parallel dimer of ANF 99–126 has been identified in plasma and its biological significance is also unknown (Miyata et al, 1987). It has been suggested, however, that the concentration of this dimer differs in various pathological conditions leading to the possible conclusion that altered processing or secretion of abnormal forms may be involved in certain disturbances of sodium and fluid balance (Arendt, 1986^b).

5.1.3 Biological Actions of Atrial Natriuretic Factor

Intravenous administration of synthetic ANF produces a marked diuresis and natriuresis. The mechanisms by which this overall effect is achieved are still uncertain. The kidney, the vasculature and the adrenal cortex have been identified as definite target organs and the combined interrelated effects of ANF on these organs supports the putative role of ANF as a hormone involved in sodium and water homeostasis. Autoradiographic and biochemical techniques have demonstrated the presence of specific receptors for ANF in these and other tissues (Napier et al, 1984; De Lean et al, 1984^a; Bianchi et al, 1985; Quiron et al, 1984)

In the kidney specific ANF receptors have been localised in the glomeruli, vasa recta and medullary collecting duct (De Lean et al, 1985; Ballerman et al, 1985; Murphy et al, 1985). ANF induced stimulation of cyclic GMP (cGMP) production, which is believed to be the second messenger of its actions (Hamet et al, 1984), exhibits the same distribution within the nephron (Tremblay et al, 1985;

Nonoguchi et al, 1987). The glomerular filtration rate and the filtration fraction show sustained elevation throughout peptide infusion and diminish abruptly when infusion is stopped (Needleman et al, 1985; Cole & Needleman, 1985).

The vascular effect of ANF is to relax smooth muscle. This effect is also mediated by cGMP (Winqvist et al, 1984). It is suggested that ANF shows a relative selectivity to different vascular beds (Garcia et al, 1985). The decreased peripheral resistance caused by ANF results in a lowering of blood pressure and diminished cardiac output (which may be secondary to a diminished venous return rather than a direct cardioinhibitory effect). ANF infusion experiments on normal and nephrectomised rats have suggested a fluid shift from the intravascular to extravascular space, due to a direct effect on capillary permeability (Almeida et al, 1986; Fluckiger et al, 1986).

Adrenal cortical cell synthesis and secretion of aldosterone is inhibited by ANF (Atarashi et al, 1984). This effect is also receptor mediated and seems to be limited to the zona glomerulosa (De Lean et al, 1984^b). Inhibition is dose related. The experiments of Maack et al (1984) and Kurtz et al (1986) indicate that the ANF effect on aldosterone is both direct and via inhibition of renin release from juxtaglomerular cells.

The presence of ANF, and ANF receptors, in brain suggests that it may have neuromodulator activity (Tanaka et al, 1984; Quiron et al, 1984). ANF-immunoreactive neurons have been localised mainly in the cardiovascular regulatory areas of the central nervous system (Saper et al, 1985). *In vitro* studies using hypothalamo-neurohypophyseal preparations have shown that ANF has an inhibitory effect on vasopressin release (Januszewicz et al, 1986; Poole et al, 1987). The capillary endothelium of the blood brain barrier and the epithelium of choroid plexus contain ANF receptors and ANF-sensitive guanylate cyclase (Steardo et al, 1987). ANF may, therefore, have a regulatory role in the movement of water in the central nervous system as well as the periphery.

5.1.4 Measurement of ANF Concentration

Bioassays measuring either the *in vivo* diuretic response or *in vitro* relaxation of smooth muscle were useful during the original isolation of atrial peptides but are not sensitive enough for the measurement of plasma concentrations.

Radioreceptor assays based on either rat glomerular ANF receptors (Ballerman *et al*, 1987) or ANF receptors isolated from bovine adrenal cortex (Burgisser *et al*, 1985) have been applied to the measurement of plasma ANF concentrations. These assays have been shown to correlate well with radioimmunoassays (Ballerman *et al*, 1987 : Sagnella *et al*, 1987) and offer the theoretical advantage of measuring only biologically active forms, however, they have not been widely used.

Radioimmunoassay is the most commonly used method for the measurement of ANF concentration in plasma. Many variants have been described, which in general can be classified as either direct assays or those utilising a pre-extraction/purification /concentration step. Wide variations in reference concentrations are quoted ranging from 10 ng/l (Tikkanen *et al*, 1985) to 300 ng/l (Tang *et al*, 1986). It is generally accepted that direct assays have a marked positive bias resulting from serum interference and are therefore not discussed further.

The diversity of quoted reference ranges within the extracted assay group can be attributed partly to physiological variations associated with sodium and water intake and also postural effects. Analytical variations, however, particularly antibody specificity, method of ANF extraction from plasma, quality of radiolabelled ANF and source of standard material can also be identified as potential contributory factors. A major point of note in this context is that corrections for analytical recovery are not consistently applied when reference ranges are calculated. Table 5.1 summarises some of the methodological variations

Table 5.1 METHODOLOGICAL VARIATIONS USED FOR THE EXTRACTION OF ANF FROM PLASMA.

<u>Author</u>	<u>Method</u>	<u>Prior Acidification</u>	<u>Extraction Elution Solvent</u>	<u>% Recovery</u>
Wilkins et al, 1986	ODS*	Yes	Acid Ethanol	58%
Rosmalen et al, 1987	ODS	Yes	Acid Ethanol	96%
Yamaji et al, 1985	Immuno Affinity chromatography	No	-----	81%
Hartter et al, 1986	ODS	---	Methanol/TFA	>98%
Nishiuchi et al, 1986	ODS	Yes	60% Acetonitrile	68%
Gutkowska et al, 1985	Adsorption to activated glass	---	Acid/Acetone	43-94%
Arendt et al, 1985	Ion exchange (Amberlite XAD-2)	---	-----	98%

* Octadecyl silane (Sep-pak cartridges)

in the extraction of ANF from plasma. Methodological variations associated with the preparation of radiolabelled ANF are described in Table 5.2. The chloramine-T method is most widely used but, several different procedures for post iodination purification are utilised.

Monoclonal antibodies to ANF have been produced (John *et al*, 1986; Naomi *et al*, 1987; Milne *et al*, 1987; Payne *et al*, 1987; Prowse *et al*, 1989; Mukoyama *et al*, 1988) and in some cases applied to the radioimmunoassay of ANF (Stasch *et al*, 1987; Naomi *et al*, 1988; Prowse *et al*, 1989). More significantly; monoclonal antibodies, in conjunction with polyclonal antisera, have been used to develop two-site immunometric assays for ANF (Lewis *et al*, 1989; Hashida *et al*, 1988). These assays do not suffer from serum interference and are sufficiently sensitive to allow the direct measurement of ANF concentration. Tattersall *et al* (1989) have also described a two-site immunoradiometric assay which uses two polyclonal antisera.

5.1.5 Plasma ANF in Pathological Conditions

In pathological conditions there appears to be a relationship between plasma ANF concentration and the volume status of the central circulation.

Plasma ANF rises markedly during atrial pacing (Gutkowska *et al*, 1985) and similar elevations are seen in paroxysmal atrial tachyarrhythmias (Schiffrin *et al*, 1985) with prompt return to normal after restoration of normal sinus rhythm. During tachycardia, plasma ANF correlates with atrial pressure, not with heart rate (Nicklas *et al*, 1986), confirming the primary role of atrial pressure in the secretion of ANF.

In congestive heart failure the increase in plasma ANF is proportional to the severity of the condition (Nakaoka *et al*, 1985), and apparently independent of the nature of the underlying heart disease (Burnett *et al*, 1986; Lang *et al*, 1985^b). Concentrations as high as ten to fifteen times normal have been found. Successful

Table 5.2 METHODOLOGICAL VARIATIONS USED FOR THE PREPARATION OF RADIOLABELLED ANF.

<u>Author</u>	<u>Iodination Method</u>	<u>Purification Method</u>
Wilkins et al, 1986*	Chloramine T	HPLC
Rosmalen et al, 1987	Protag-125	HPLC
Iinuma et al, 1987	Chloramine T	Gel Filtration
Nishiuchi et al, 1986	Chloramine T	Ion exchange chromatography (carboxymethyl cellulose)
Yandle et al, 1986	Chloramine T	Gel Filtration Sep-pak and HPLC
Yamaji et al, 1985	Chloramine T	Gel Filtration and HPLC
Nakao et al, 1984	Chloramine T	Sep-pak (ODS)
Perry et al, 1987	Lactoperoxidase	HPLC

* As supplied by Amersham International

treatment is associated with a fall in ANF concentration (Katoh *et al*, 1986).

Raised circulating levels of ANF are found in volume overloaded patients with chronic renal failure and levels fall with fluid removal during dialysis (Wilkins *et al*, 1986).

Primary aldosteronism, which is also characterised by hypervolaemia, results in increased concentrations of ANF. Removal of the adenoma or diuretic therapy restores basal concentrations (Tunny *et al*, 1986).

Estimates of ANF concentrations in essential hypertension have been variable. Comparisons with normotensive groups have in some studies shown an elevation of ANF concentration with, however, some overlap between groups (Sagnella *et al*, 1986; Sugawara *et al*, 1985; Arendt *et al*, 1986^b). On the contrary, Garcia *et al* (1986), found no difference in the ANF concentrations of essential hypertensive and normotensive subjects.

Contradictory data is also reported in patients with liver cirrhosis with ascites. Despite markedly expanded extracellular fluid volume, normal (Shenker *et al*, 1985), slightly elevated (Gerbes *et al*, 1986) and significantly elevated (Naruse *et al*, 1986) baseline concentrations have all been reported. Since increased atrial pressure is not a typical feature of decompensated liver cirrhosis, these data are not inconsistent with the view that atrial pressure is the primary stimulus of ANF release.

Maternal plasma blood volume increases gradually by about 40–50% during pregnancy (Pritchard *et al*, 1984). Otsuki *et al* (1987) have shown that plasma ANF concentrations also increase gradually throughout pregnancy. In addition a significant increase in ANF concentration was found when comparing normal pregnant subjects to patients with pre-eclamptic toxemia.

It has been suggested that Bartter's syndrome might be explained as a syndrome of inappropriate secretion of ANF since this condition is characterised by volume depletion and concentrations of ANF are elevated (Tunny *et al*, 1986^a;

Yamada *et al*, 1986). Tunny *et al*, (1986^b) also suggested, from data obtained in one patient, that impaired responsiveness of ANF secretion to volume loading may play a role in Gordon's syndrome, the mirror-image condition of Bartter's syndrome.

It is evident that the increase in plasma ANF concentration in most conditions is likely to be a compensatory response to the expansion of extracellular fluid volume and/or to elevated blood pressure rather than a cause of the pathophysiological event. The usefulness of ANF measurements in diagnostic or therapy monitoring will be equivocal until physiological and pathophysiological mechanisms are fully elucidated.

As this project began the structure of ANF had just been confirmed and the first radioimmunoassays described. From these early descriptions it was evident that assay sensitivity was likely to be a key problem. The variations in cited reference ranges and the gross differences between direct and extracted assays also suggested potential problems with either specificity and or matrix effects. These factors prompted an attempt to produce monoclonal antibodies to ANF with a view to developing a two-site immunoradiometric assay. The initial strategy was to attempt to pre-determine specificity by using synthetic fragments of ANF as immunogens.

5.2.1 Initial Immunisations

Synthetic ANF 99–126, the N-terminal heptapeptide (ANF 99–105) and the C-terminal hexapeptide (ANF 121–126) were used as immunogens. The N and C terminal fragments were used alone and also conjugated to KLH (keyhole limpet haemocyanin). These KLH conjugates were commercially prepared by Cambridge Research Biochemicals using N-maleimidobenzoyl-N'-hydroxysuccinimide ester to C-terminally couple the N-terminal heptapeptide and to N-terminally couple the C-terminal hexapeptide.

Each of these preparations was used to immunise three balb/c mice. Primary intraperitoneal immunisation in Freund's complete adjuvant was followed by two secondary doses in incomplete adjuvant at three week intervals. The administered doses of immunogens on each occasion were :- ANF 99–126 10 μ g, ANF 99–105 and ANF 121–126 50 μ g and KLH conjugates 100 μ g. Multiple site subcutaneous immunisation of DA strain rats was also performed according to the same time schedule with a total of 50 μ g of ANF 99–126 being administered on each occasion. Test bleeds were taken from all animals three weeks after the final dose of

immunogen.

5.2.2 Assessment of Response to Immunisation

The assessment of the response to immunisation required the production of radiolabelled ANF 99–126. Since this peptide has a C-terminal tyrosine residue, 2µg were iodinated by a standard lactoperoxidase method with 18.5 MBq of ¹²⁵iodine. Post iodination purification was by gel filtration through a 28 x 1.6 cm column of Sephadex G25 (fine). The elution buffer was buffer 3 pumped at a flow rate of 16 ml/h and 0.8 ml fractions were collected. Intrinsic radioactivity was counted for 10 seconds. The resultant profile is shown in Figure 5.3.

Serial dilutions of test bleeds ranging from 1/50 to 1/50000 were prepared in phosphate buffered saline (pH 7.4). 200 µl of each dilution was then incubated, at 40°C with 200 µl of radiolabelled ANF 99–126, for 18 hours. The bound fraction was separated by incubation with Sepharose coupled antibody (2 mg Sepharose/tube), either sheep anti-mouse polyclonal antibody or sheep anti-rat polyclonal antibody, for 1 hour at ambient temperature. Sepharose particles were subjected to three centrifuge, wash, aspiration cycles with 3 x 2 ml saline.

Independent dilutions of all the test bleeds gave binding of <2.0%. Negative results posed the question as to whether the animals did not respond to the immunogens used or whether the screening assay was not detecting the response. It was therefore decided to check the screening assay.

5.2.3 Evaluation of the Screening Assay

Since the separation reagents used in this assay functioned well in other assay systems the primary target for evaluation was the I¹²⁵ ANF 99–126 preparation. A commercial rabbit anti-ANF 99–126 antibody, supplied by CRB (Cambridge Research Biochemicals), was used to assess the immunological integrity of the I¹²⁵ ANF 99–126 preparation.

Counts
 $\times 10^3/10s$

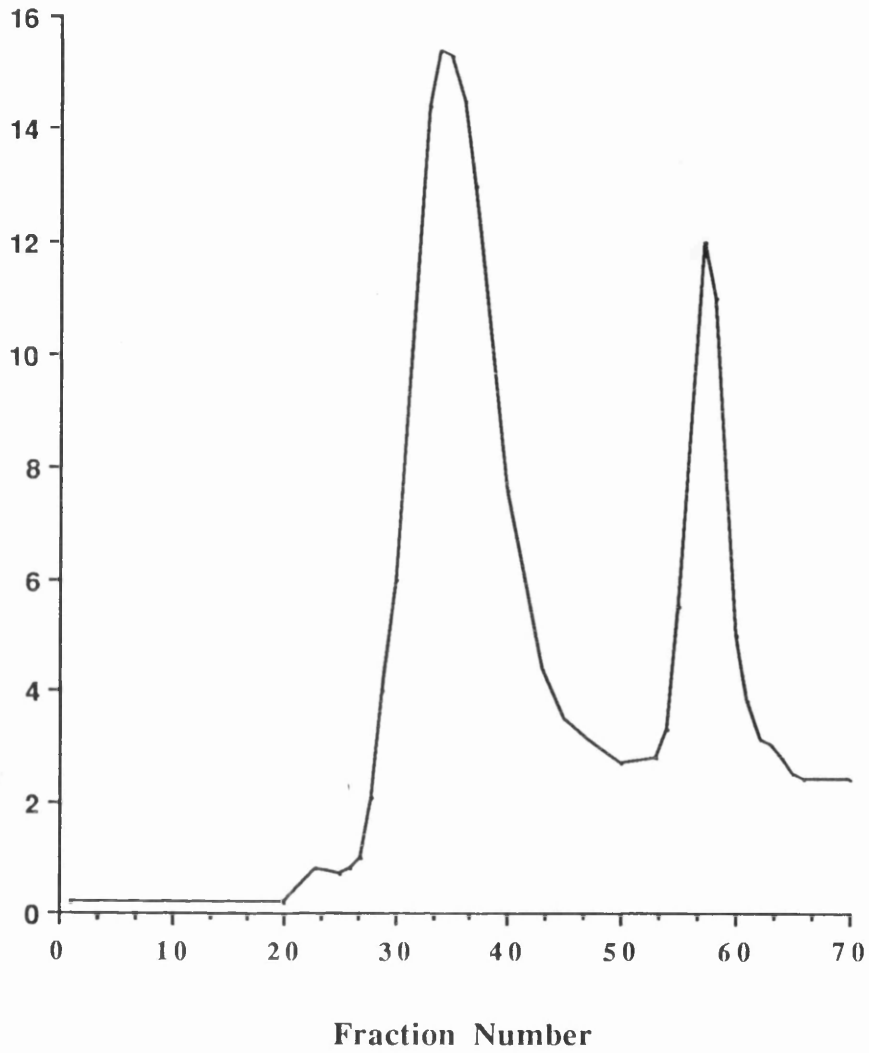

Figure 5.3 Gel filtration purification of radiolabelled ANF.

Rabbit anti-ANF was serially diluted in buffer 6 and each of the dilutions incubated with I^{125} ANF at ambient temperature for 18 hours. Bound fraction was separated by a further incubation for 1 hour with Sepharose coupled DAR antiserum, followed by 3 centrifuge/wash cycles with 2ml of saline. The percentage of radioactive ANF bound is plotted against antibody dilution in Figure 5.4. The radiolabelled ANF had some immunoreactivity, however the maximum binding achieved was disappointing. This is likely to be due to either radiation damage, oxidation damage, deterioration of the peptide on storage or altered affinity for the peptide when the tyrosine residue is iodinated. The latter is unlikely since the CRB antibody is reported to be specific for the mid region of ANF.

To evaluate this further a 100 μ l aliquot of the radiolabelled ANF (4 days post gel filtration) was subjected to HPLC through a Waters 0.39 x 30 cm column of 10 μ C18 μ Bondapak with a solvent gradient from 20% acetonitrile in 0.08% trifluoroacetic acid to 50% acetonitrile over 60 minutes. Flow rate was 1 ml/minute and 1 ml fractions were collected. Intrinsic radioactivity of each fraction was counted for 10 seconds. The resultant profile, Figure 5.5, shows that the single peak seen post gel filtration was resolved into five peaks by HPLC. An aliquot of the synthetic peptide was subsequently subjected to HPLC under identical conditions using an optical detection system, absorbance being measured at a wavelength of 214 nm. Figure 5.6 demonstrates that the peptide prior to iodination was homogeneous. The rising absorbance seen from 22 minutes onwards is a function of the optical imbalance of the solvents used to create the elution gradient.

The heterogeneous mixture found post iodination is therefore likely to be caused by either radiation or oxidation damage.

5.2.4 Development of an HPLC Purification Method

The post iodination HPLC profile described above consistently produced multiple peaks but proved difficult to reproduce. Reported HPLC purification

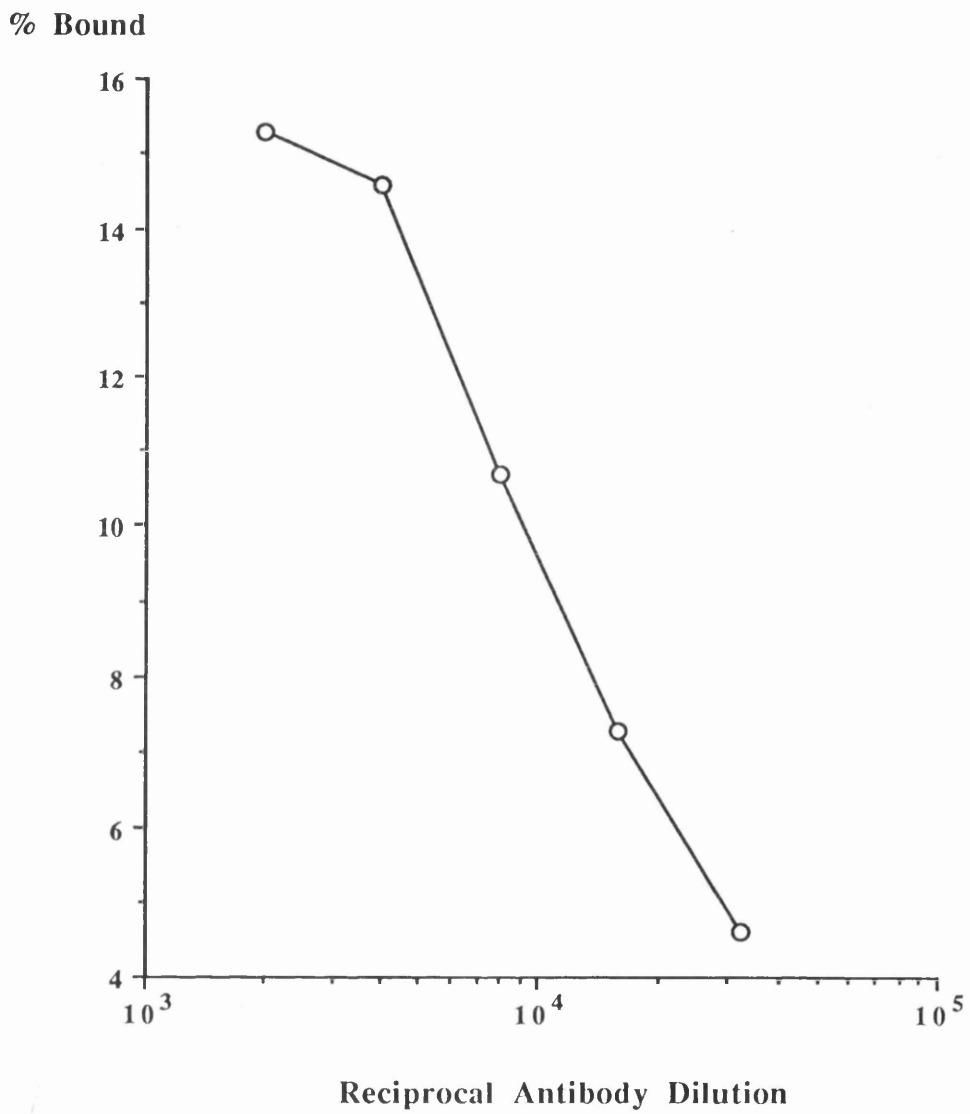

Figure 5.4 Rabbit anti-ANF (CRB) dilution curve.

Counts
 $\times 10^3 / 10s$

% ACN

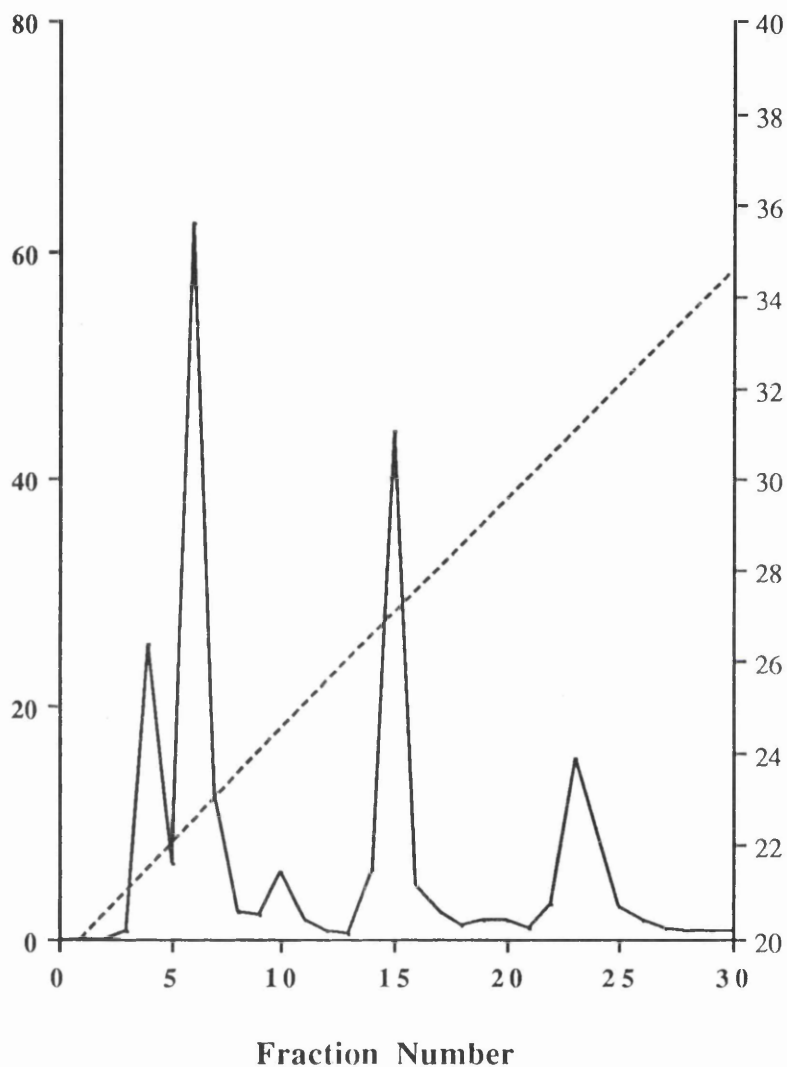

Figure 5.5 Preliminary purification of radiolabelled ANF by HPLC (----- indicates the acetonitrile gradient).

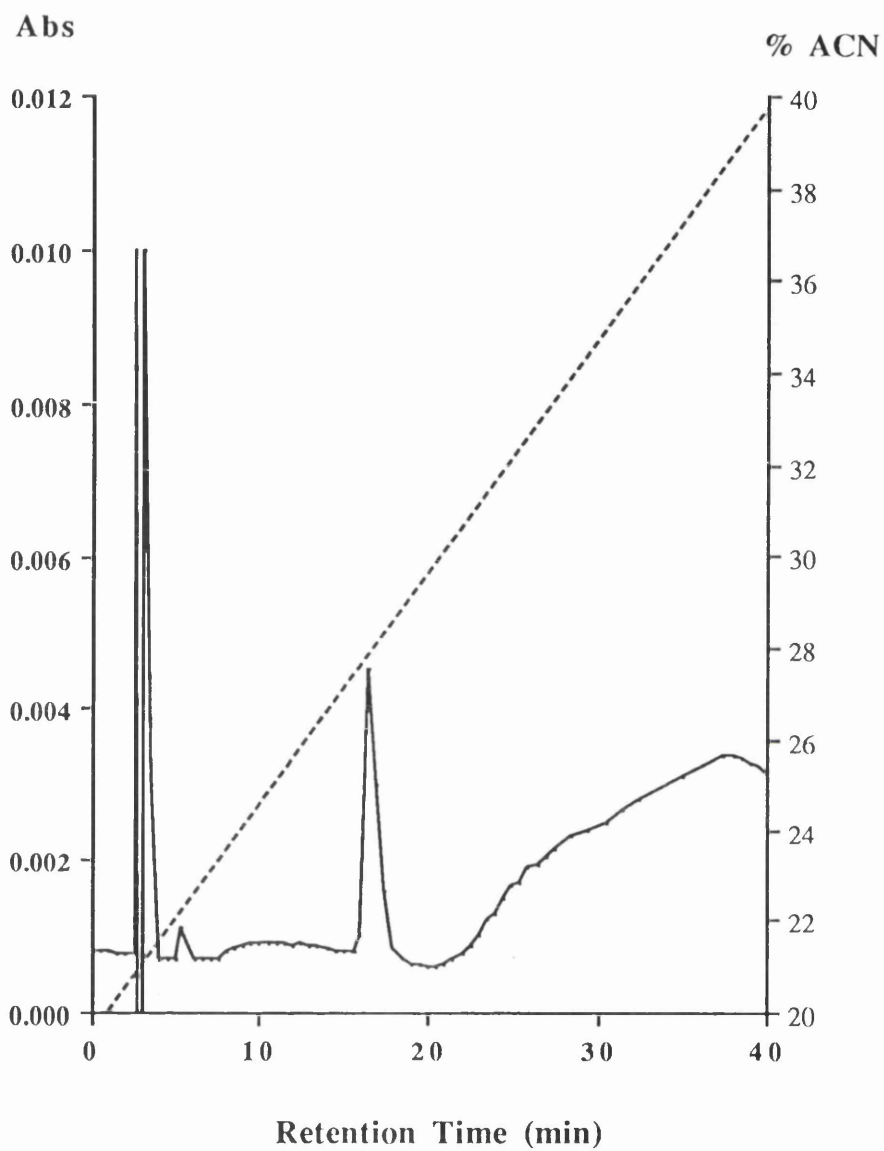

Figure 5.6 Examination of ANF purity by HPLC (----- indicates the acetonitrile gradient).

procedures using chloramine-T as the oxidising agent describe a radioiodine peak and two peptide peaks the latter being thought to be mono and di-iodinated forms of the peptide (Yandle *et al*, 1986).

A series of experiments were conducted in which solvent flow rate, concentration of acetonitrile in the starting solvent, slope of the solvent gradient, size of fractions collected and sample loading onto the column were modified in order to stabilise the resultant profile and improve the resolution of peaks.

Immunoreactivity studies using a rabbit anti-ANF (code 716/9 supplied by the Blood Pressure Unit, Western Infirmary, Glasgow) were conducted on the fractionated peaks. The final optimised conditions were :-

Column dimensions:	30 x 0.39 cm
Column packing:	Waters μ Bondapak C18 10 μ
Solvent A:	0.08% trifluoroacetic acid
Solvent B:	70% acetonitrile in 0.08% TFA
Flow rate:	0.5 ml/minute
Starting solvent mix:	28% A in A+B
Gradient:	Linear to 60% B in A+B over 96 minutes
Fraction size:	0.5 ml

These conditions consistently demonstrated resolution of the lactoperoxidase iodination mixture into five peaks (Figure 5.7). In immunoreactivity studies with polyclonal anti-ANF peak 1 showed no binding and was confirmed as unreacted iodine by gel filtration selecting only the protein peak only for HPLC. Peaks 2-5 showed varying degrees of immunoreactivity, percentages of maximum binding being 37, 63, 35 and 57 respectively, with peaks 3 and 5 exhibiting better immunoreactivity.

A simultaneous optical trace (Figure 5.8) resolved six peaks C, D, E and F corresponding to 2, 3, 4 and 5 on the radiotrace. Peaks A and B could therefore be

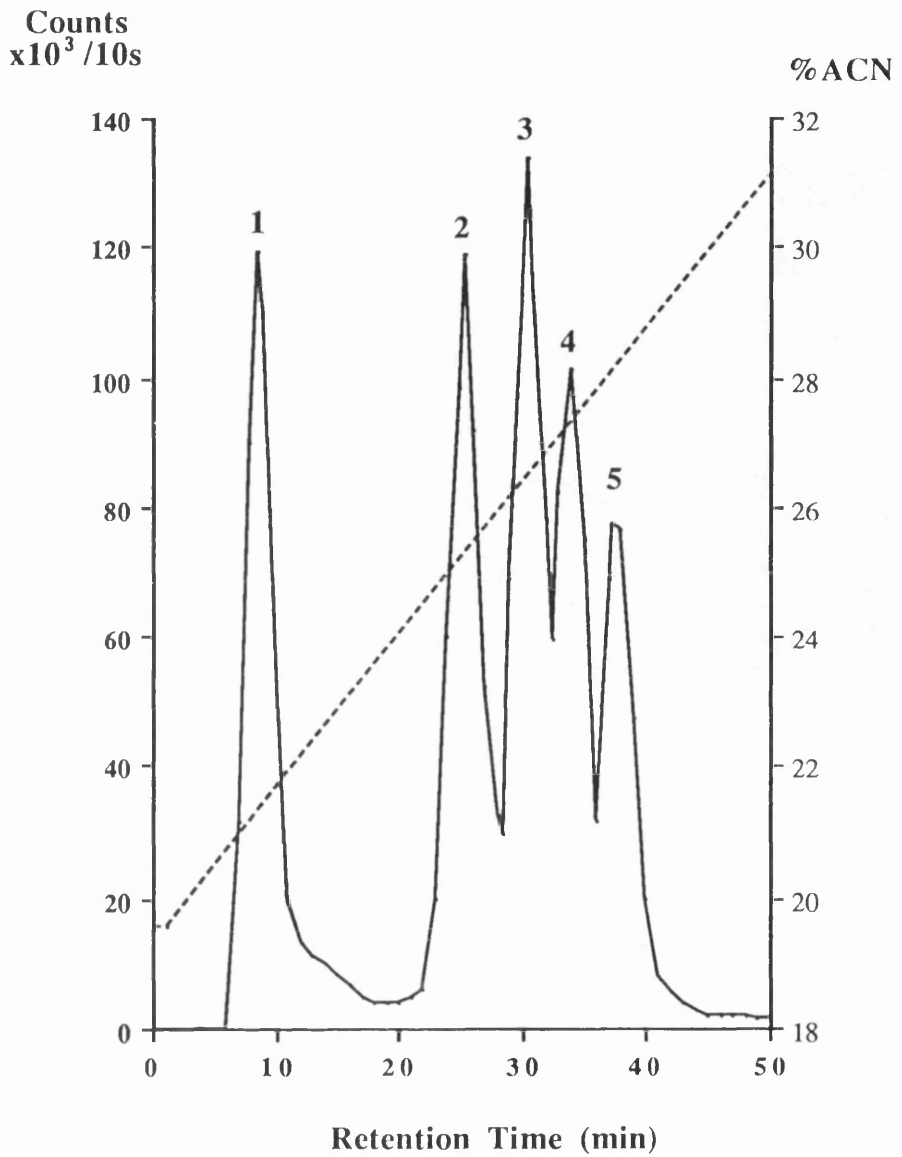

Figure 5.7 Radioactive HPLC profile of ANF post lactoperoxidase iodination (----- indicates the acetonitrile gradient).

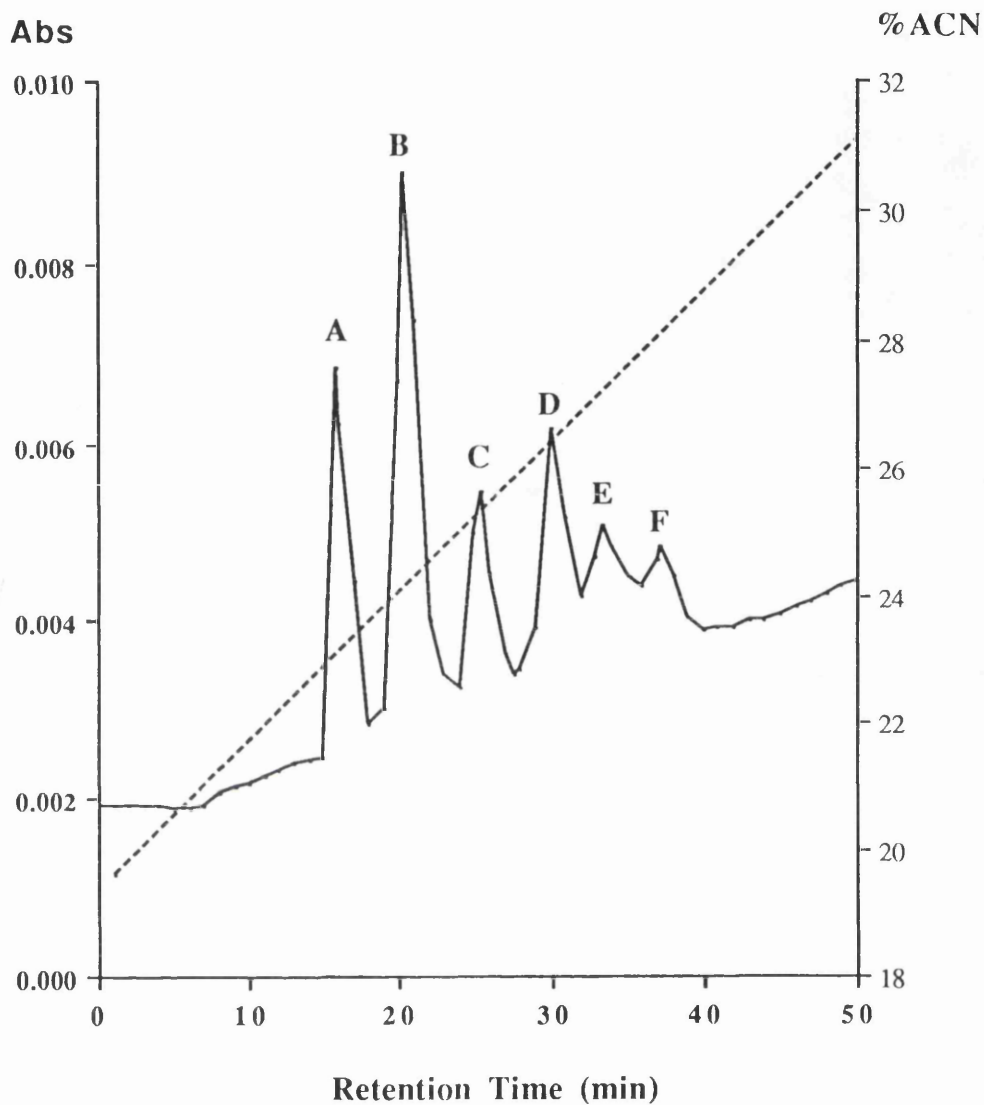

Figure 5.8 Optical HPLC profile of ANF post lactoperoxidase iodination (----- indicates the acetonitrile gradient).

confirmed as uniodinated peptide. It had previously been shown that the ANF peptide prior to iodination is homogenous (Figure 5.6) therefore the oxidation reaction appears to have generated a derivatised form of ANF. Given the primary structure of ANF, this is most likely to be a methionine sulphoxide form of ANF.

This postulate was tested by a series of experiments in which simultaneous optical and radiotraces monitored the products of lactoperoxidase iodinations of ANF 99–126 and Met[O]110 ANF 99–126. The native peptides were also individually subjected to HPLC together with a commercial mono iodotyrosyl ANF 99–126 supplied by Amersham International. The resultant profiles are shown in Figure 5.9. These experiments confirmed the identity of all peaks:–

Peak 1	unreacted iodine
Peak A	unreacted Met[O]110 ANF 99–126
Peak B	unreacted ANF 99–126
Peak C/2	mono iodo Met[O]110 ANF 99–126
Peak D/3	mono iodo ANF 99–126
Peak E/4	di-iodo Met[O]110 ANF 99–126
Peak F/5	di-iodo ANF 99–126

However, the demonstration of four immunoreactive peaks on the radiotracer and six peaks on the optical trace is at variance with previously published reports of HPLC purification of ANF post iodination. Since these reports all describe chloramine T iodinations it was decided to use the developed HPLC purification method to ascertain whether the differences observed were related to the method of iodination.

5.2.5 Comparison of Radioiodination Methods

The chloramine T method was examined because of its widespread use and to see if the differences observed on lactoperoxidase iodination are attributable to

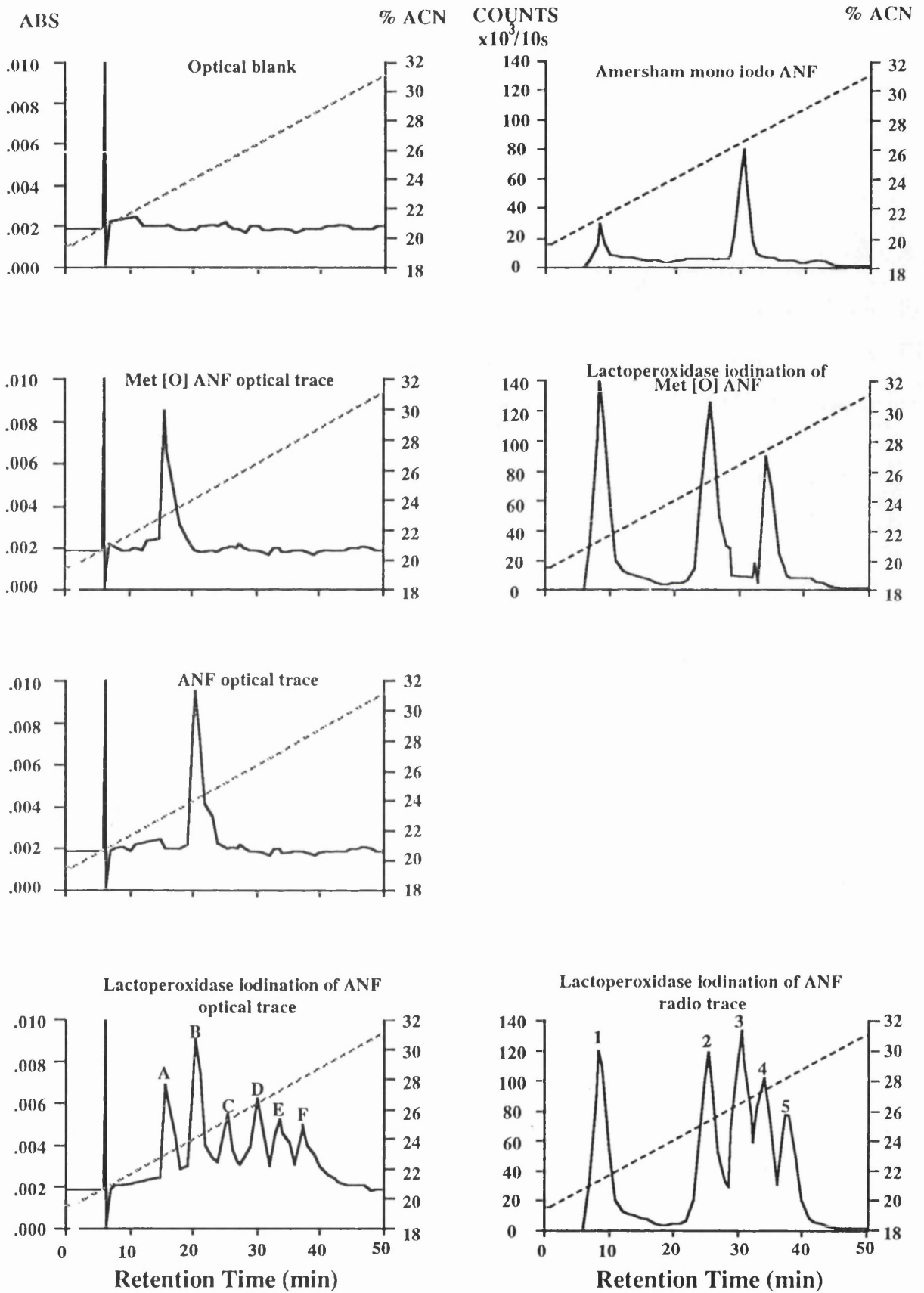

Figure 5.9 Comparison of radio and optical HPLC profiles for ANF 99-126 and Met[O]110 ANF 99-126 before and after iodination. A commercial mono-iodo ANF 99-126 is shown for reference

iodination method. Radioiodination methods using Iodogen (Fraker & Speck, 1978) or N-bromosuccinimide (Reay, 1982) as oxidising agent have been reported to be less damaging to peptides and proteins. These were therefore examined to see if they offered any improvement in comparison with the lactoperoxidase method.

ANF 99–126 (5 µg) was reacted with 37 MBq 125 Iodine by each of the above methods (Chapter 2, section 2.2.4). The HPLC purification profiles are shown in Figure 5.10. With chloramine T as oxidant, 35 nmol/l final concentration, only three peaks were observed on the radiotrace corresponding to unreacted iodine and mono and di-iodinated Met[O]110 ANF99–126. This suggests that the chloramine T method oxidises ANF extensively. The Iodogen and NBS methods gave profiles similar to lactoperoxidase with the degree of incorporation of radioiodine varying as a function of the molar concentration of oxidant in the reaction mixture (Iodogen 12nmol/l : LP 4 nmol/l : NBS 1 nmol/l). Immunoreactivity studies on the peaks isolated from each iodination (Table 5.3) showed consistently better performance for peaks D and F.

Since the chloramine T method gave poor performance as a consequence of over oxidation the oxidant concentrations were reduced to 6 nmol/l and 3 nmol/l (approximately equivalent to the lactoperoxidase method) and the experiments repeated. Radiotraces (Figure 5.11) improved marginally producing some mono and di-iodo ANF 99–126 but there was still a marked preferential production of mono iodo Met[O]110 ANF 99–126.

The alternative iodination methods did not offer any advantages in comparison to lactoperoxidase, the chloramine T method in particular proven to be inappropriate for the production of mono iodo ANF 99–126 (Perry *et al*, 1987).

5.2.6 Further Immunisations

Having successfully derived a reproducible method for the production of highly purified 125 I mono iodo ANF 99–126 further immunisations were

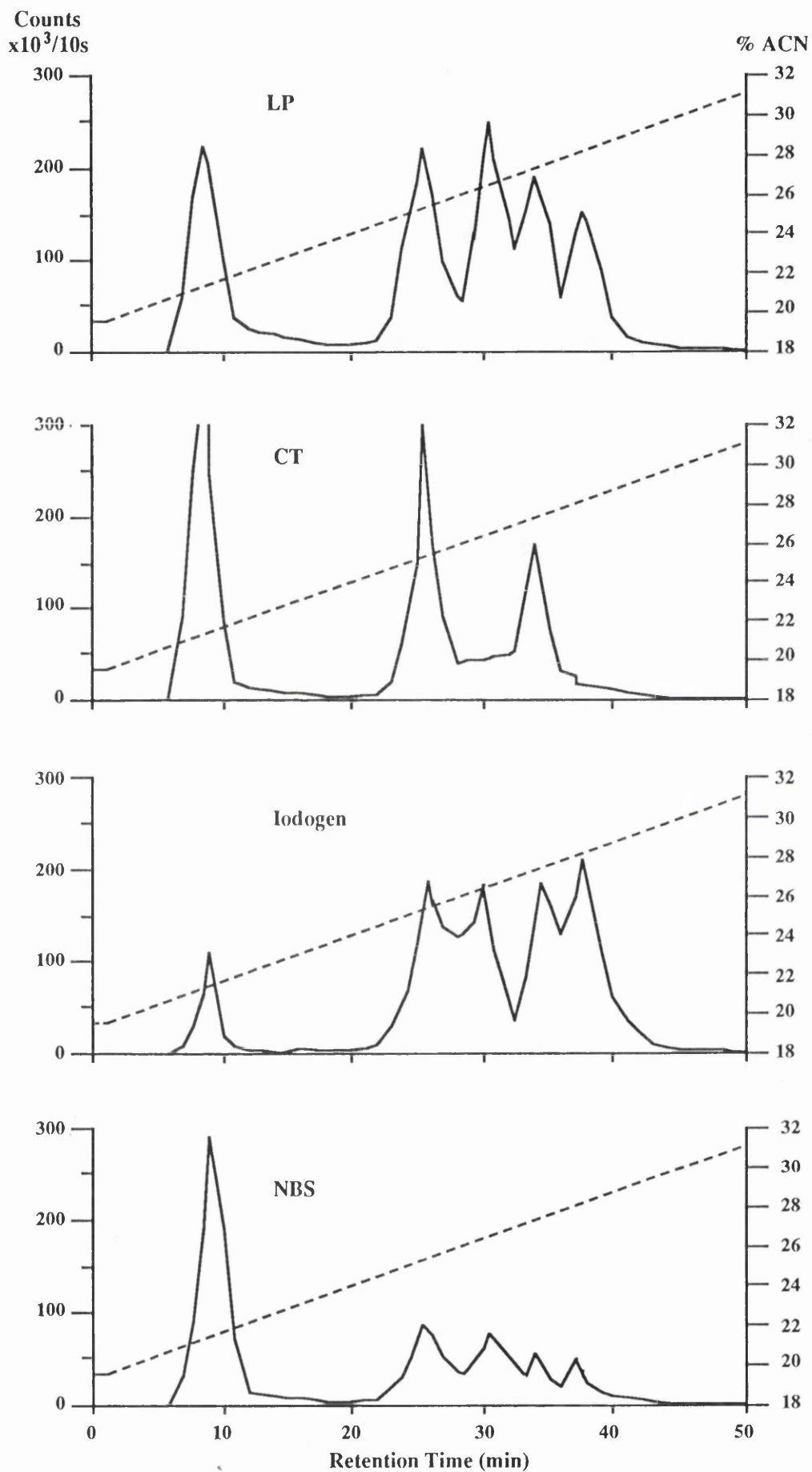

Figure 5.10 Comparison of the HPLC radioiodination profiles for ANF 99-126 by four methods. LP=Lactoperoxidase : CT=Chloramine T : NBS=N-Bromosuccinimide

**Table 5.3 IMMUNOACTIVITY OF THE RADIOIODINATED PEPTIDES ISOLATED BY HPLC
FROM FOUR IODINATION PROCEDURES**

	LP (4)	CT (35)	Iodogen (12)	NBS (1)
Peak C	37	20	27	26
Peak D	63	-	49	47
Peak E	35	22	34	33
Peak F	57	-	46	45

() nmol/l oxidant in the final reaction mixture.

LP = Lactoperoxidase ; CT = Chloramine T ; NBS = N-Bromosuccinimide

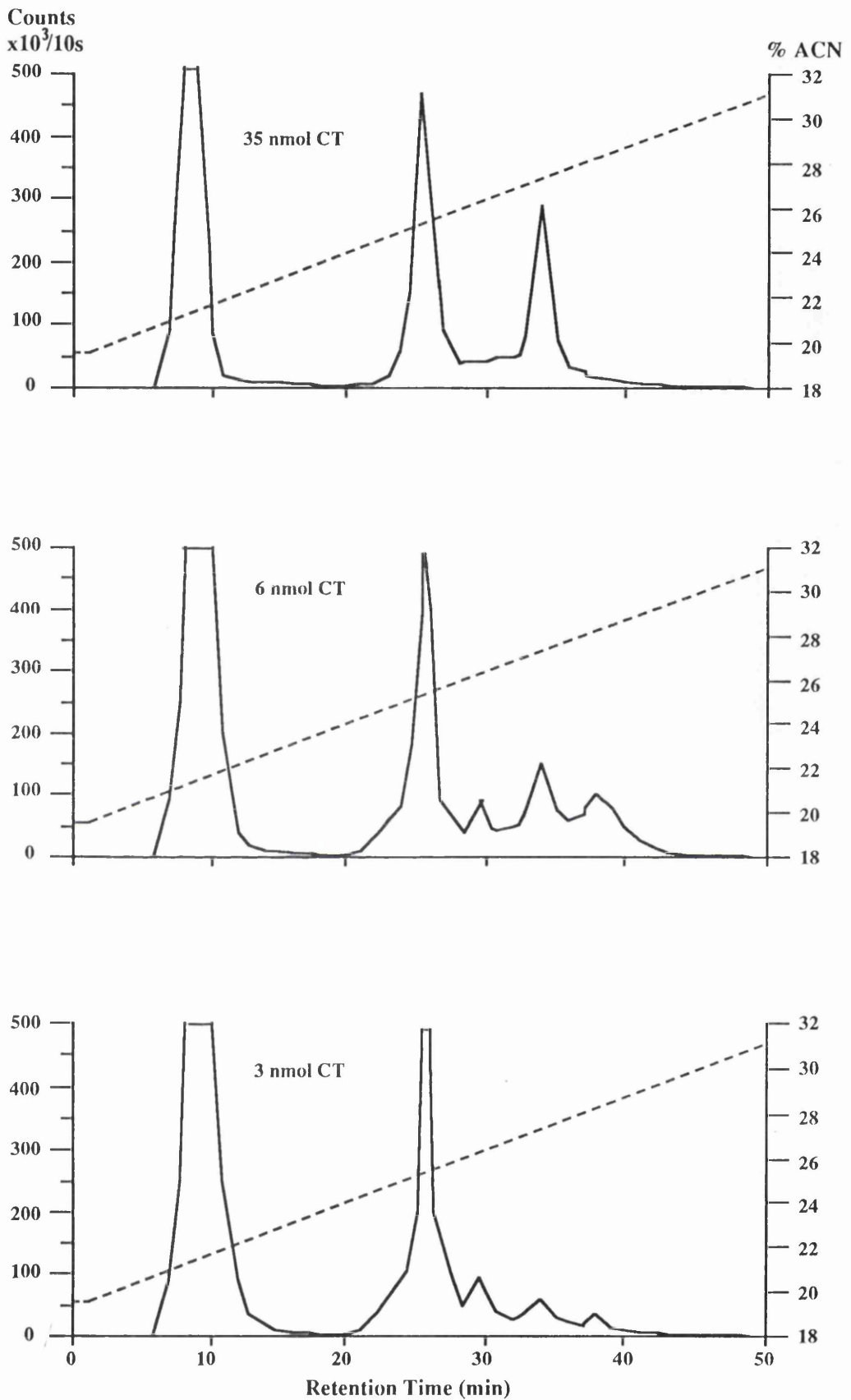

Figure 5.11 Comparison of the HPLC radioiodination profiles for ANF 99-126 by chloramine T at three molar concentrations

performed. The immunogens used were the ANF 99–105 and ANF 121–126 KLH conjugates and bovine serum albumin conjugates of ANF 99–126, ANF 99–105, ANF 121–126, ANF 99–109 and ANF 111–126 prepared by the method of Staros *et al* (1986) (Chapter 2, section 2.2.5).

Three balb/c mice and three first generation crosses of balb/c and NZB mice were immunised intraperitoneally with 50 µg of each immunogen according to the time schedule previously described. Test bleeds were taken from the tail veins of all animals following the final dose of immunogen. Screening of test bleeds for the presence of specific antibody revealed that the ANF 121–126 KLH conjugate elicited a response in the NZB/balb/c F1 hybrids, all other tests were negative. Figure 5.12 shows the responses obtained in NZB/balb/c F1 hybrids to the C-terminal (M1–M3) and the N-terminal (M4–M6) KLH conjugates.

A further 5 NZB/balb/c F1 hybrids were immunised with ANF 121–126 KLH conjugate according to the same schedule and a definite response, although of low titre, was seen in four of the five animals (Figure 5.13).

The spleens of these animals were subsequently used in a series of hybridisation experiments.

5.2.7 Hybridisation Experiments

Initially eight hybridisation experiments were conducted. The selected animal for each experiment was given a priming intravenous dose of ANF 121–126 four days prior to the experiment and in some cases an additional intraperitoneal dose of the conjugated peptide 10 days prior to fusion. This variation had no apparent effect on the outcome of the experiment. At splenectomy abdominal distension was noted in several of the sacrificed animals caused by splenomegaly, fluid retention in the peritoneal cavity or both. Spleen weights were variable ranging from 190 mg to 1900 mg. Cardiac punctures were performed to retrieve serum from the sacrificed animals. Each hybridisation experiment consisted of three

% Bound

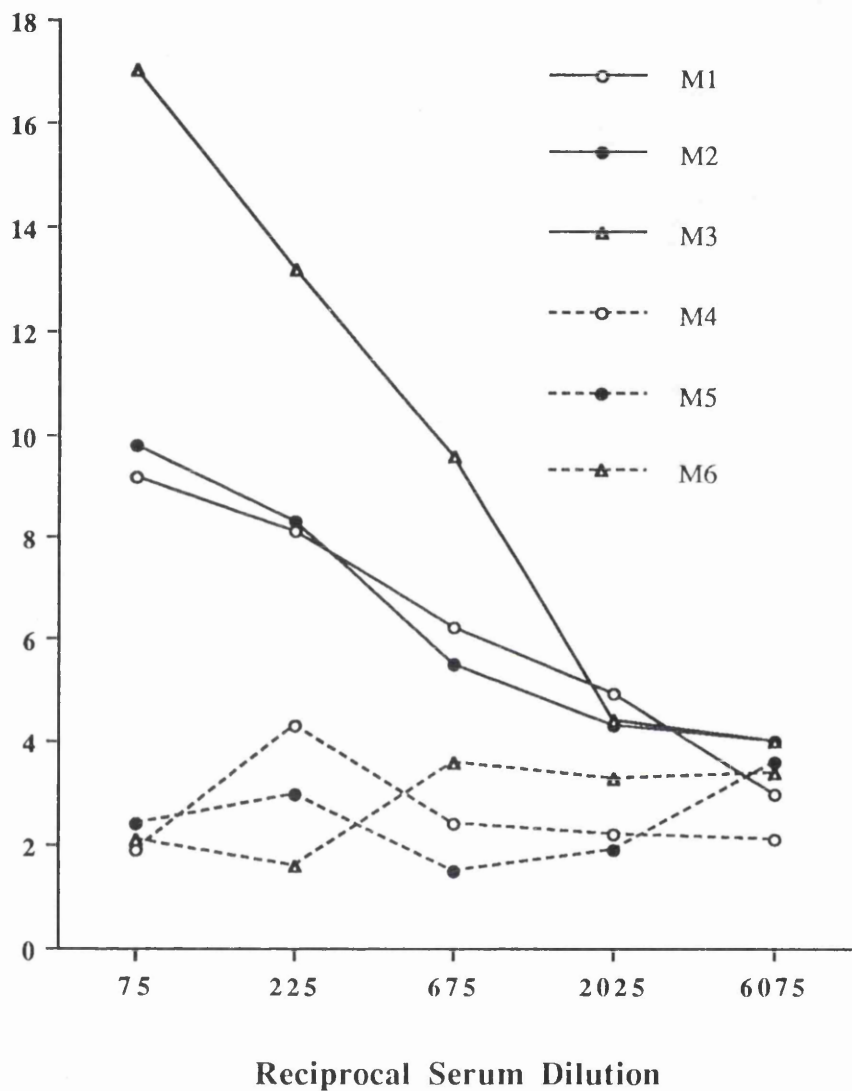

Figure 5.12 Antibody dilution curves for NZB/Balb/c F1 hybrid mice immunised with ANF fragments conjugated to KLH. M1-M3 = ANF 121-126 : M4-M6 = ANF 99-105.

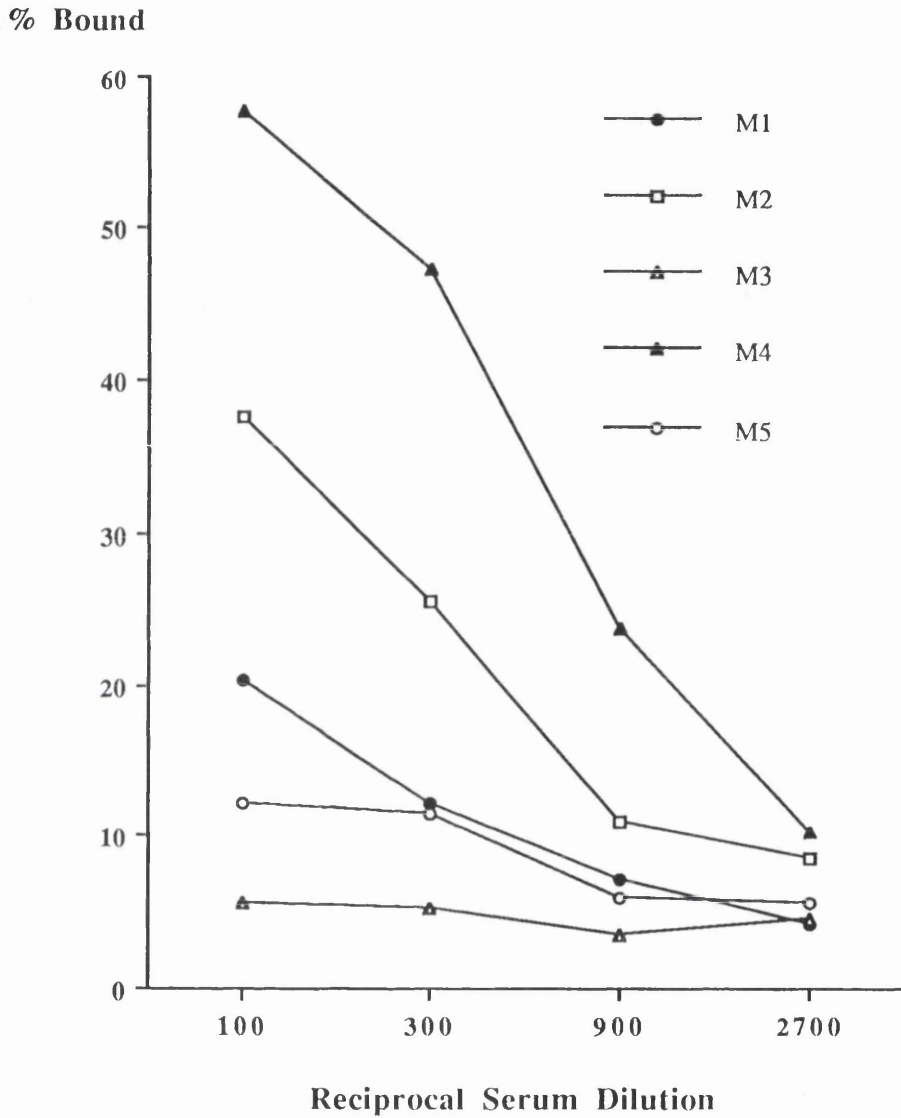

Figure 5.13 Antibody dilution curves for a further five NZB/Balb/c F1 hybrid mice immunised with ANF 121-126 KLH conjugate.

separate fusions as previously described in Chapter 3.

5.2.8 Assessment of Fusion Experiments

All fusions generated growing hybrids in approximately 50% of the seeded wells. The rate of hybrid growth was consistent with previous experiments and supernatants were removed for testing 10–12 days post fusion. The screening assay involved the incubation of 50 μ l of supernatants with I¹²⁵ mono iodo ANF 99–126 for 18 hours followed by separation of the bound fraction with Sepharose coupled polyclonal sheep anti–mouse γ –globulin antibody. Serial dilutions of mouse serum, previously shown to contain specific antibody on examination of tail vein bleeds, were used as positive controls in the screening assay.

In four of the eight hybridisation experiments no specific antibody containing wells were identified. The four remaining experiments generated 66 wells in which binding of >10% was demonstrated. However, on visual inspection of these wells the majority were found to contain no growing hybrid cells. Presumably the antibody detected was derived from cells which had subsequently died. In total the contents of 31 wells were cloned by limiting dilution. Subsequent testing of supernatants from cloning plates, despite adequate hybrid growth, showed that no secretors of specific antibody had survived. This finding is not consistent with previous experience with GH antibodies (Chapter 3, section 3.2.4.) or PTH antibodies (Chapter 4, section 4.2.3.).

The most common reasons for an inability to successfully clone by limiting dilution are chromosomal changes or over growth by other hybrids. In the light of obvious splenomegaly and the knowledge that KLH is a potent immunogen a third possible explanation may be that the separation component of the screening assay is compromised by a high concentration of antibody specific for KLH. The efficiency of Sepharose coupled sheep anti–mouse γ –globulin as a separating reagent was therefore examined.

5.2.9. Examination of the Efficiency of Separation.

The efficiency of the Sepharose coupled sheep anti-mouse γ -globulin (SAM) was tested by comparison with a polyethylene glycol/ γ -globulin precipitation separation system. The optimum concentrations of PEG and bovine γ -globulin were determined by adding a radiolabelled mouse anti-TSH monoclonal antibody to a 1/400 dilution of normal mouse serum and precipitating the antibody with a combination of PEG and bovine γ -globulin at various final concentrations (2–20% and 0.01–1% respectively). Final concentrations of 10% PEG and 0.1% bovine γ -globulin were found to be optimum.

The relative efficiency of these two separation methods was assessed by comparison of their ability to precipitate a radiolabelled monoclonal anti-TSH in the presence of normal mouse serum and serum derived from a mouse immunised with ANF 121–126 KLH conjugate. Dilutions of the two mouse sera were prepared from 1/50 to 1/6400. Samples (100 μ l) of each dilution were mixed with 200 μ l of radiolabelled anti-TSH (20000 cpm). Precipitation of radiolabel was by the addition of either 200 μ l of Sepharose coupled SAM (2mg/tube), followed by three centrifuge/wash cycles with 2 ml of saline, or 200 μ l of 0.5% bovine γ -globulin and 500 μ l of 20% polyethylene glycol 6000 followed by mixing and centrifugation at 2000 rpm for 20 minutes.

Figure 5.14 illustrates the impaired efficiency of solid-phase sheep anti-mouse separation in the presence of serum from an immunised mouse. The polyethylene glycol/ γ -globulin system was not affected.

This experiment was repeated substituting I¹²⁵ ANF 99–126 for the radiolabelled anti-TSH monoclonal antibody and incubating for 18 hours prior to separation thus creating a standard antibody dilution experiment with a non-specific binding estimate (derived from the data on the normal mouse serum) for each dilution. The results, corrected for non-specific binding, clearly demonstrate

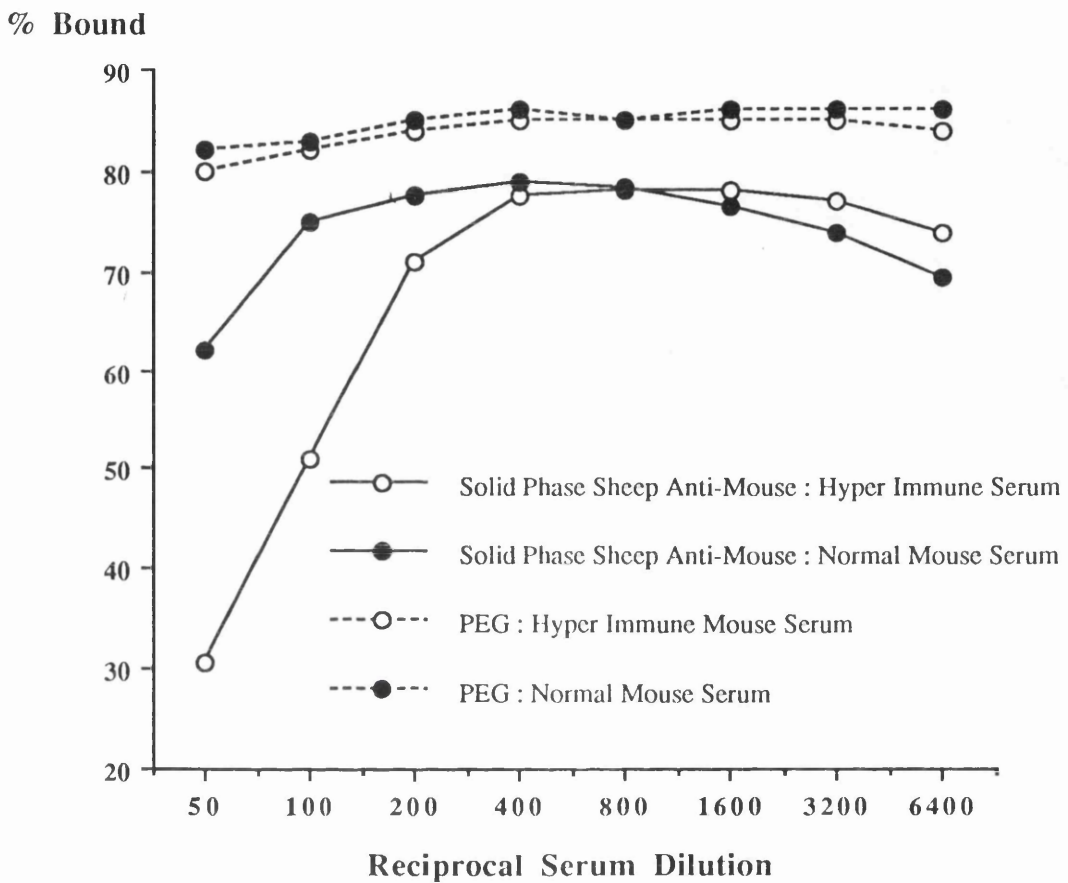

Figure 5.14 Comparison of solid phase sheep anti-mouse and PEG/ γ -globulin separation systems in normal mouse serum and hyper immune mouse serum.

the greater efficiency of the polyethylene glycol/ γ -globulin system at low serum titres (Figure 5.15) and that the solid-phase SAM system was compromised when examining test bleeds from animals immunised with KLH conjugates. This would also indicate the potential for problems when screening supernatants where very high concentrations of anti-KLH antibodies are present. A further series of hybridisation experiments were conducted using the polyethylene glycol separation system in the screening assay.

5.2.10 Assessment of Further Hybridisation Experiments

Three further hybridisation experiments were performed. The supernatants from 61 wells were identified as giving binding in excess of 20%, this level of binding being chosen as an indicator of positivity since the PEG/ γ -globulin system was known to give non-specific binding levels of approximately 12%. Again, several of these wells on visual inspection did not contain viable cells. The contents of 25 wells were cloned by limiting dilution. Supernatants were tested 14 days post cloning and screening showed that no secretors had survived. This would suggest that chromosomal losses or over growth by non secreting hybrids are responsible for the inability to successfully clone secreting cell lines rather than inadequacies of the screening assay.

After 33 fusions had been performed, and consequently over 15800 wells screened, over a two year period, four monoclonal antibodies and a polyclonal antibody became available from other sources. It was therefore decided not to pursue the production of further antibodies but to attempt to utilise those available.

5.3 CONCLUSIONS

The production of monoclonal antibodies to ANF 99-126 has proved to be particularly difficult. This is primarily due to the fact that this peptide shows considerable sequence homology between species and is not therefore a good

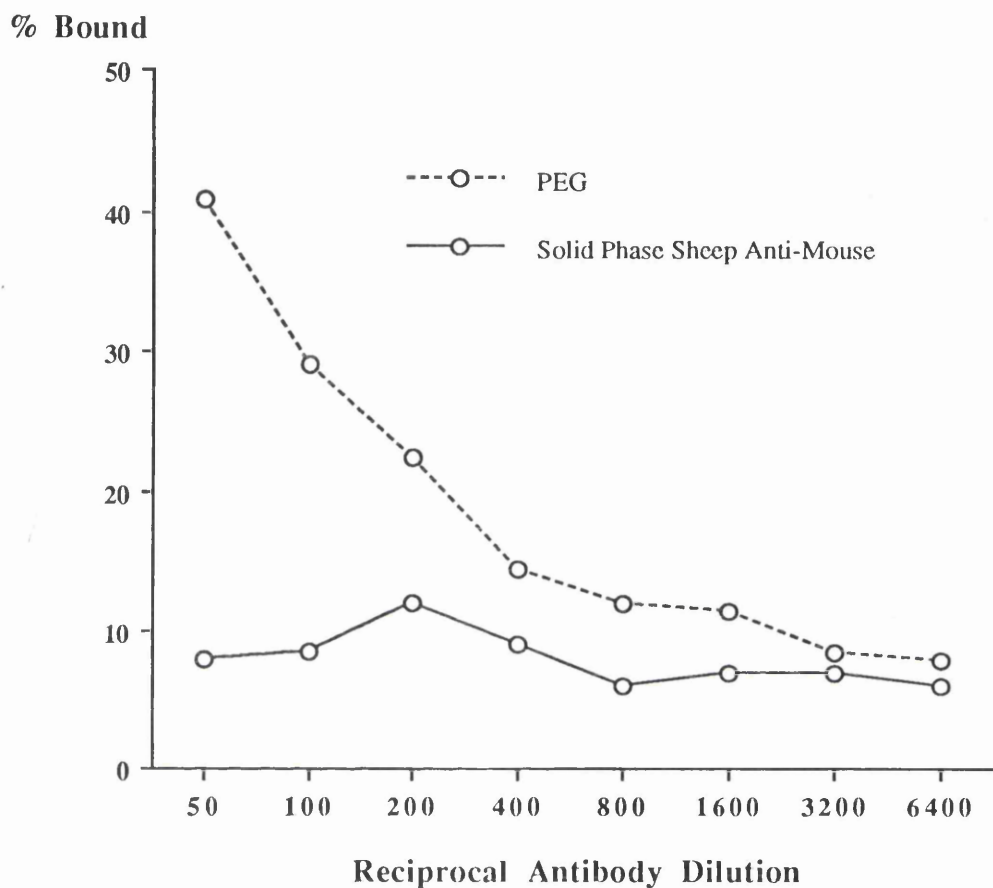

Figure 5.15 Antibody dilution curves for an individual mouse serum immunised with ANF 121-126 KLH conjugate : comparison of two separation systems.

immunogen. Substitution of the methionine residue at position 110 with isoleucine is the only variation reported in the mouse, rat and rabbit. The ANF 121–126 KLH conjugate was the only immunogen to produce a response and then only in NZB/Balb/c F1 hybrid mice. The implications of this observation will be considered further in Chapter 7.

The detailed experiments on radioiodination and post iodination purification of ANF 99–126 question the validity of a number of reported assays for the measurement of ANF due to their use of radiolabels produced by the chloramine T method. It has been demonstrated clearly that this method produces I^{125} Met[O]110 ANF 99–126 and therefore a heterogeneous assay system. The specificity of antisera and the handling of standard material and samples in this situation is of critical importance. Immunoreactivity studies (Table 5.3) under standard conditions using rabbit anti-ANF (code 716/9) indicate that this antibody has a greater avidity for non oxidised ANF. Rosmalen *et al* (1987) confirmed these observations.

The use of simultaneous optical and radiotracers (Figures 5.7–5.9) demonstrates that the lactoperoxidase iodination method does not iodinate all of the peptide and that some of the peptide is oxidised but not iodinated. This has implications for the calculation of specific activity of radiolabelled peptides.

Results in Figure 5.10 show a gradation of oxidation and iodination related to the molar concentration of oxidant used in each of four iodination methods. Reaction times are considerably different, however, ranging from 10 and 15 seconds respectively for the chloramine T and N-bromosuccinimide methods to 10 minutes for the iodogen and lactoperoxidase methods. This suggests that the same end result could be achieved by any of these methods given the correct balance between oxidant concentration and incubation time. However this view is not supported by the chloramine T data in Figure 5.11 which shows that despite a reduction in the molar concentration of oxidant to that of the other methods,

Met[O]110 ANF is still produced preferentially. This evidence suggests that use of chloramine T is inadvisable due to the poor yield of mono iodo ANF 99–126.

CHAPTER 6

DEVELOPMENT OF AN ASSAY FOR THE MEASUREMENT OF ANF CONCENTRATION IN PLASMA

Three monoclonal antibodies to ANF coded ESA4, ESA5, and ESA9 were supplied, in the form of both neat ascitic fluid and Protein A purified IgG, by Dr C. Prowse (Royal Infirmary, Edinburgh). The isotypes of these antibodies are IgG2a, IgG2b and IgG1 respectively. Antibodies ESA4 and ESA5 appear to be directed to the 105–110 region of ANF99–126 and insensitive to the substitution of the methionine residue for isoleucine at position 110. Antibody ESA9 recognises human ANF105–126 but not rat ANF103–126 suggesting a binding site which includes the methionine residue at position 110, and requires an intact bridge between residues 105–121 (Prowse *et al.*, 1989).

A fourth monoclonal antibody was supplied by Dr A. Thakur (Middlesex Hospital). This antibody, coded 3H5, was supplied as dilute ascitic fluid. The antibody binding site has been reported to be in the 99–109 region of ANF99–126 (Payne *et al.* 1987).

These four monoclonal antibodies along with the rabbit polyclonal anti-ANF (716/9), supplied by the Blood Pressure Unit of the Western Infirmary Glasgow, were examined with a view to their utilisation in either a two-site immunoradiometric assay or a radioimmunoassay.

6.2 ASSESSMENT OF ANTIBODY TITRES AND RELATIVE AFFINITIES

Serial dilutions of the five antibodies ranging from 1/500 to 1/409600 were prepared in buffer 6. Aliquots (100 μ l) of each dilution were incubated for 18 hours at ambient temperature with 100 μ l of I¹²⁵ ANF99–126 (10 pg/tube) and 100 μ l of buffer 6. The bound fraction was separated by a further incubation with 100 μ l (1mg/tube) of either Sepharose coupled sheep anti-mouse gamma globulin or donkey anti-rabbit polyclonal antibody, followed by three

centrifuge/wash/aspiration cycles with 2 ml of saline. Radioactivity in each tube was counted for two minutes. The percentage of I^{125} ANF99–126 bound is shown as a function of antibody dilution in Figure 6.1.

A parallel experiment was conducted in which the 100 μ l of buffer in the primary incubation mixture was replaced with 100 μ l of ANF 99–126 at a concentration of 1880 ng/l. The percentage of bound I^{125} ANF 99–126 displaced by this concentration of "cold" ANF 99–126 is plotted for each antibody dilution in Figure 6.2.

The polyclonal antibody 716/9 and the monoclonal antibody ESA4 have higher affinities for ANF 99–126 than the three other monoclonal antibodies. These two antibodies would therefore be considered as having the greatest potential for producing immunoassays with maximal sensitivity.

6.3 ASSESSMENT OF ANTIBODY COMPLEMENTARITY

The assay method of choice would be a two-site immunometric assay. This would require two antibodies directed to independent epitopes. To ascertain whether amongst the five antibodies available a complementary pair existed the monoclonal antibodies were radiolabelled and all five antibodies coupled to Sepharose particles. All possible combinations were then evaluated.

6.3.1 Radiolabelling of Monoclonal Anti-ANF Antibodies

Prior to iodination the ascitic fluid containing the antibody 3H5 required purification. Affinity purification was chosen because of the limited amount of ascitic fluid available. A 5 ml column containing Protein A Sepharose CL4B was equilibrated with buffer 9. A 100 μ l aliquot of 3H5 ascitic fluid was applied to the column. Buffer 9 (pH 9.0) was pumped through the column at a flow rate of 12 ml/h. The absorbance of the column effluent was monitored at a wavelength of

% Bound

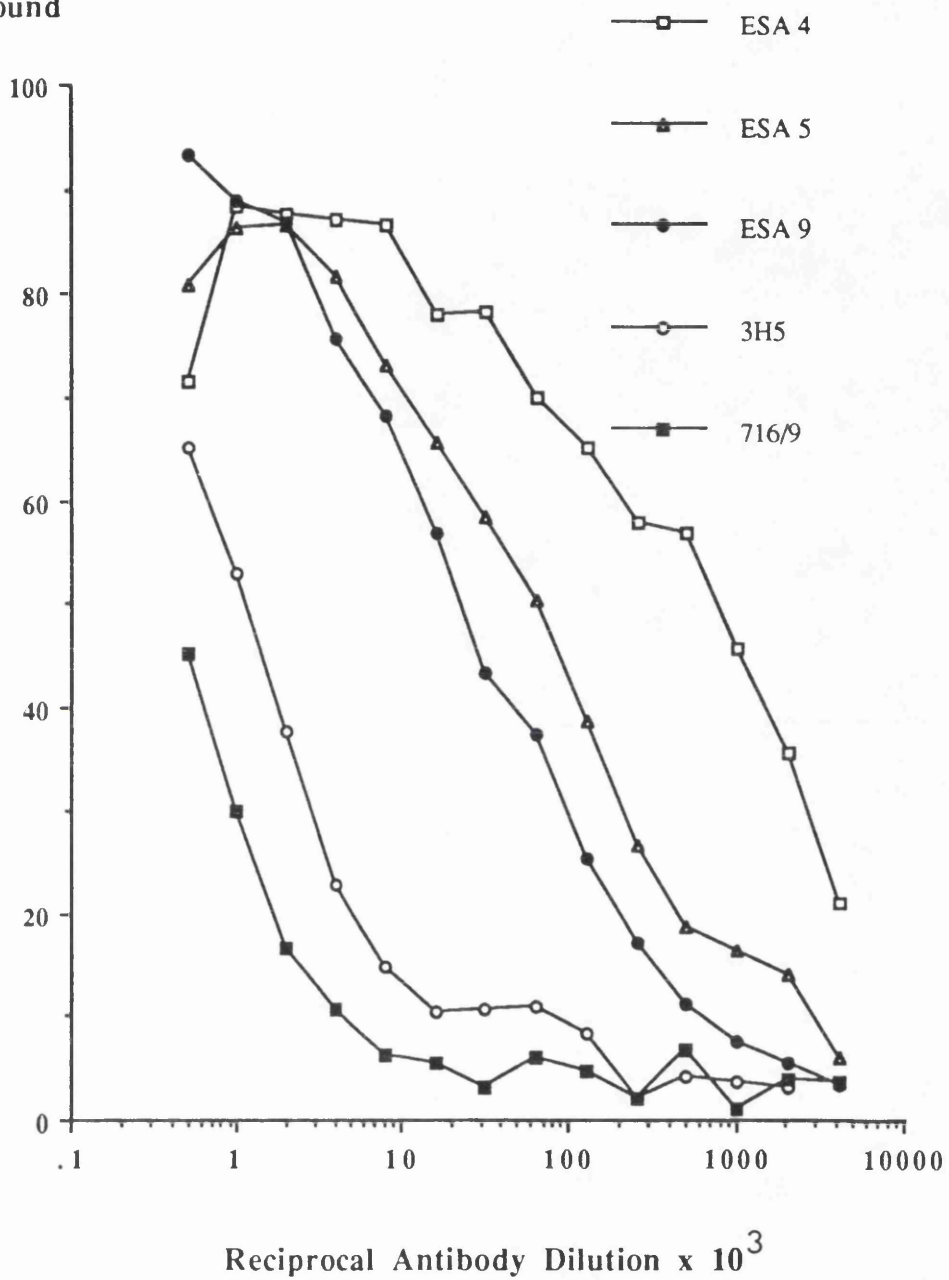

Figure 6.1 Assessment of ANF antibody titres.

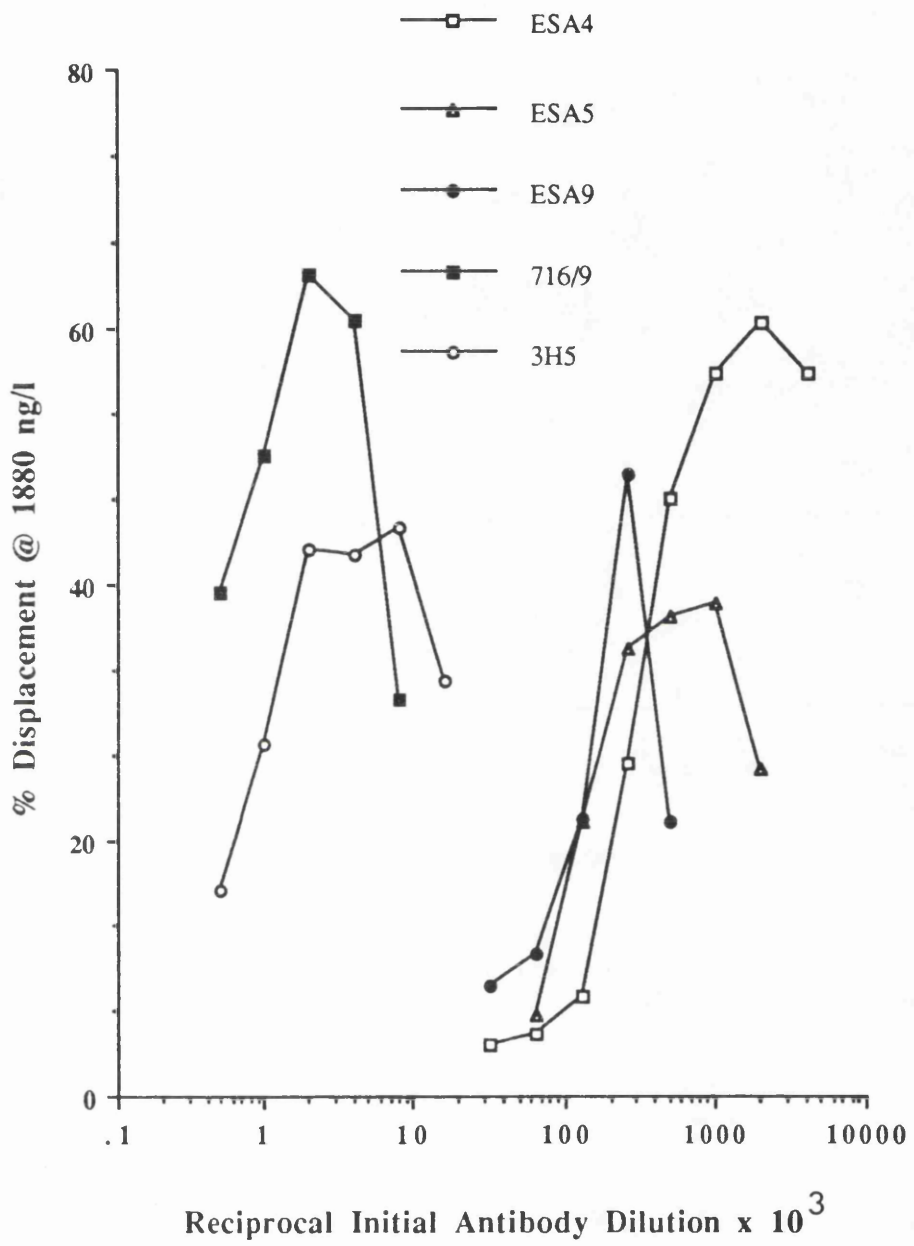

Figure 6.2 Assessment of relative affinities of anti-ANF antibodies.

280nm. When the absorbance generated by non bound material returned to baseline buffer 10 (pH 6.0) was pumped through the column at the same flow rate to release bound immunoglobulin. The fraction containing immunoglobulin was collected. The column was then regenerated by pumping first buffer 10 (pH3.0) and then buffer 9 (pH9.0) each for three hours. The absorbance profile obtained is shown in Figure 6.3. Finally the collected immunoglobulin fraction was concentrated x40 and the buffer switched to buffer 1 using the Amicon Centricon System with a molecular weight cut-off of 30000.

The Protein A purified fractions of the four monoclonal antibodies were iodinated by the chloramine T method (Chapter 2, section 2.2.4). Post iodination purification was by gel filtration through a 25 x 1.6 cm column of Sephadex G25. The elution buffer was buffer 6 pumped at 30 ml/hr and 1ml fractions were collected. Iodination profiles are shown in Figure 6.4.

6.3.2 Coupling of Monoclonal Antibodies to Sepharose CL4B

Sepharose CL4B was activated and 50 μ l aliquots of the neat ascitic fluids were coupled to 5 ml aliquots of activated gel by the method described in (Chapter 2, section 2.2.3). The concentration of Sepharose particles in each case was adjusted to 10 mg/ml. The efficiency of coupling was tested by incubating duplicate 100 μ l aliquots (1mg/tube) of each preparation with 100 μ l I¹²⁵ ANF99-126 (20 pg/tube) for 2 hours at ambient temperature with constant agitation. Bound I¹²⁵ ANF99-126 was separated by three centrifuge/wash/aspiration cycles with 2 ml of saline. Sepharose coupled sheep anti-mouse antibody was used as a negative control. Results of these binding experiments (Table 6.1) indicate successful coupling. The lower binding achieved by solid phased 3H5 antibody reflects the use of dilute ascitic fluid.

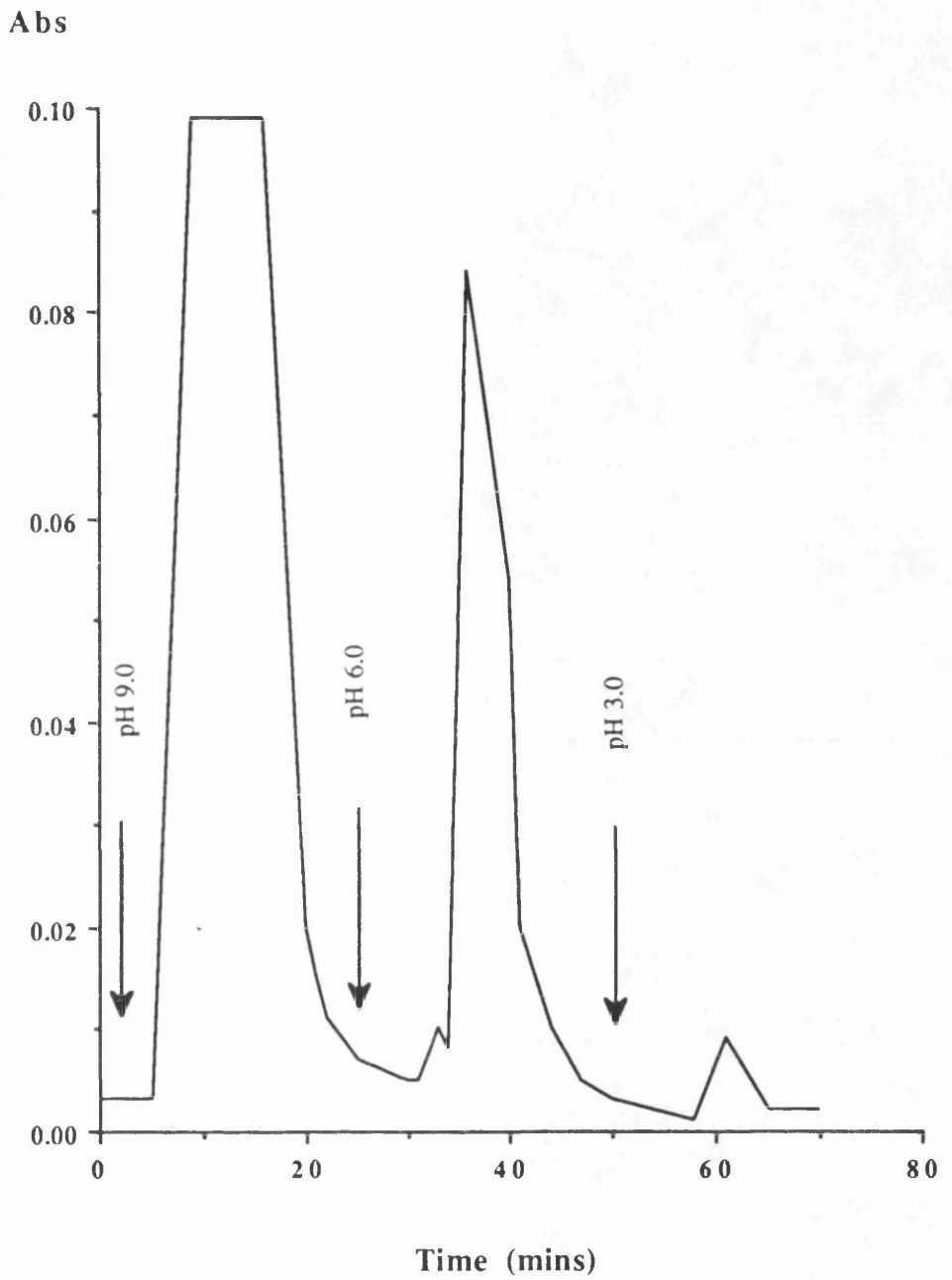

Figure 6.3 Affinity purification of anti-ANF 3H5.

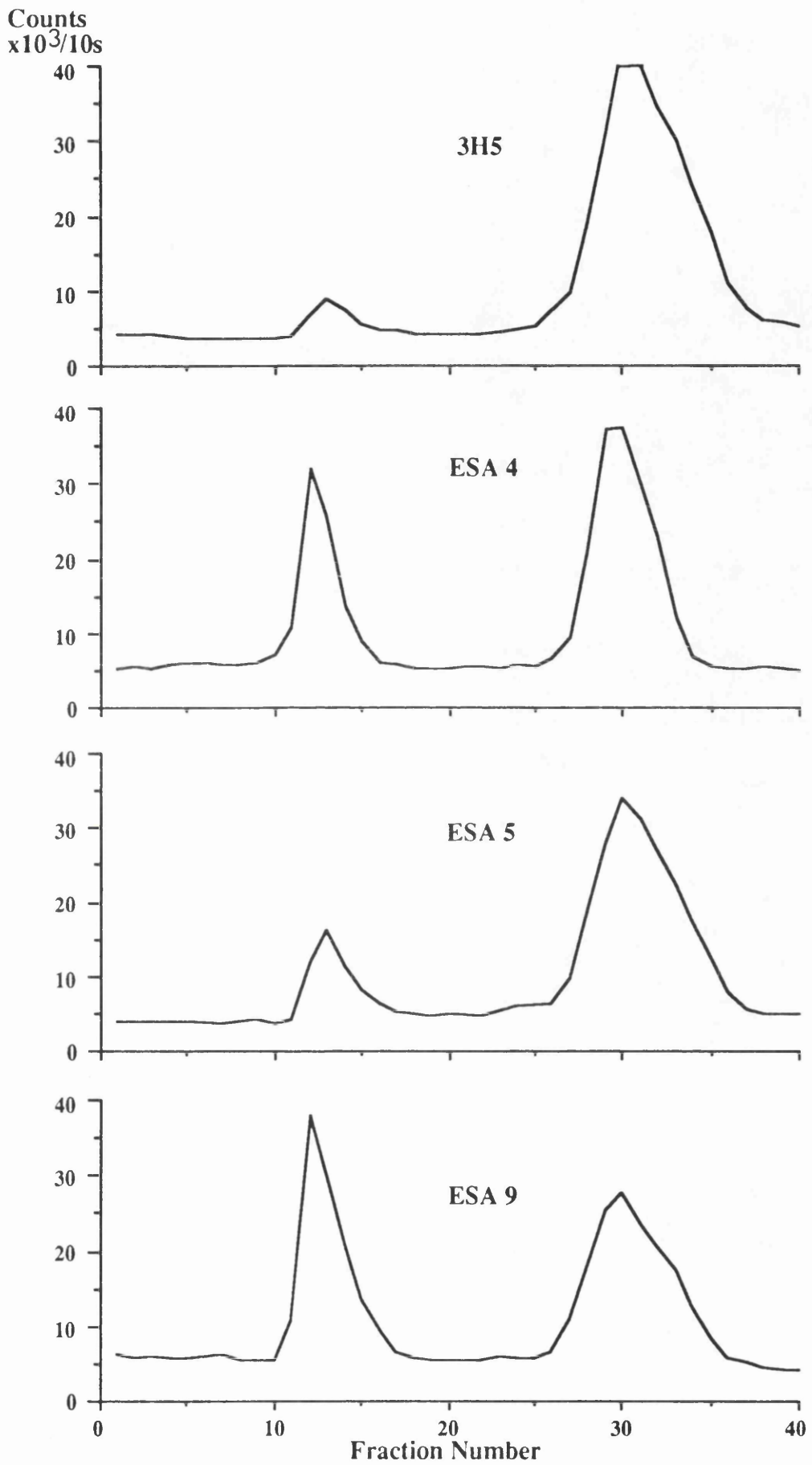

Figure 6.4 Iodination profiles of anti-ANF antibodies.

Table 6.1 COUPLING OF MONOCLONAL ANTIBODIES TO SEPHAROSE CL-4B

	Antibody Code	%Bound
	ESA4	97.2
	ESA5	97.0
	ESA9	93.9
*	3H5	48.1
†	SP-SAM	1.6

* Not neat ascitic when supplied

† Negative control (i.e. NSB)

6.3.3 Coupling of Polyclonal Anti-ANF (716/9) to Sepharose CL4B

Since the amount of this material available was limited it was decided to couple this antibody to solid phase indirectly. A polyclonal donkey anti-rabbit antibody (supplied by SAPU) was therefore coupled to Sepharose CL4B by the method described in Chapter 2, section 2.2.3. A 3 ml aliquot of this material (10 mg Sepharose/ml) was mixed with 3 ml of a 1/500 dilution of rabbit anti-ANF (716/9) and incubated at ambient temperature with constant mixing for 60 minutes. Unbound anti-ANF was then removed by subjecting the Sepharose particles to three centrifuge/wash/aspiration cycles with 10 ml of buffer 1. Particle concentration was then adjusted to 10 mg/ml. This material was tested in the same manner as the coupled monoclonal antibodies (described in section 6.3.2) and binding of 63% of added I^{125} ANF 99-126 was observed.

6.3.4 Assessment of Complementarity

Each of the four radiolabelled monoclonal antibodies and the five solid phase coupled antibodies were used in conjunction with each other in the following protocol:-

100 μ l radiolabelled monoclonal antibody

100 μ l ANF99-126 (320 ng/l)

Incubate for 1 hour at ambient temperature

200 μ l solid phase coupled antibody

Incubate for 1 hour at ambient temperature (constant agitation)

Centrifuge/wash/aspiration x3 with 2 ml saline

Count radioactivity for 60 seconds

A second set of tubes was prepared in parallel in which the ANF99-126 in the primary incubation mixture was replaced with 100 μ l of buffer 6. The percentage of the radiolabelled monoclonal antibodies bound was calculated for each combination

(Table 6.2), the buffer substitution providing a blank in each case. Results indicate that no complementary combination of these antibodies was found and therefore a two-site immunometric assay with these antibodies is not possible. Consequently the monoclonal antibody ESA4 was selected for use in a radioimmunoassay. This antibody was preferred to the rabbit polyclonal anti-ANF because of its greater titre.

6.4 DEVELOPMENT OF A RADIOIMMUNOASSAY

There are several factors which determine the performance of a radioimmunoassay the most significant of which are the characteristics of the primary antibody. Inherent antibody characteristics are fundamental to the outcome of optimisation procedures particularly with regard to achievable sensitivity, working range and assay specificity.

6.4.1 Choice of Antibody Dilution

The results presented in Figure 6.2 indicate that the dilution of antibody likely to give an assay of maximum sensitivity is $1/6 \times 10^6$ (final dilution). This dilution was therefore used in an initial attempt at a radioimmunoassay. The protocol was as follows :-

200 μ l	ANF Standard	(range 0-7520 ng/l)
100 μ l	ESA4 Anti-ANF	(initial dilution $1/1.7 \times 10^6$)
50 μ l	I^{125} ANF	(10pg/tube : 10000cpm)

Incubate at ambient temperature for 18 hours

100 μ l Sepharose CL4B coupled sheep anti-mouse (0.25 mg/tube)

Incubate for 1 hour with constant agitation

Centrifuge/Wash/Aspirate x4 with 2 ml of saline

Count radioactivity for 120 seconds

Table 6.2 EVALUATION OF ANTIBODY COMPLEMENTARITY

	[ANF]	3H5-SP	ESA4-SP	ESA5-SP	ESA9-SP	716/9-SP
I125-3H5	0 ng/l	1.3	1.2	1.1	1.3	2.8
	320 ng/l	1.1	1.3	1.1	1.1	2.9
I125-ESA4	0 ng/l	0.8	0.4	0.5	0.4	3.5
	320 ng/l	0.8	0.7	0.6	0.7	2.9
I125-ESA5	0 ng/l	0.6	0.5	0.5	0.5	8.8
	320 ng/l	0.5	0.6	0.5	0.5	8.9
I125-ESA9	0 ng/l	0.4	0.4	0.4	0.4	3.1
	320 ng/l	0.5	0.6	0.4	0.4	3.1

The dose response curve derived from this experiment (Figure 6.5) suggests that this assay would not be sufficiently sensitive for the direct measurement of ANF in plasma.

6.4.2 Effect of Delayed Addition of I¹²⁵ANF

The effect of delayed addition of I¹²⁵ANF was assessed by comparison of variable incubation steps prior to the addition of radiolabelled ANF in the above protocol. Figure 6.6 presents the dose response curves obtained suggesting that some improvement in sensitivity is gained when I¹²⁵ANF is added after a 24 hour primary incubation. This minor improvement again would not produce an assay of sufficient sensitivity to allow a direct assay.

6.4.3 Effect of the Mass of I¹²⁵ANF Added

The effect of the mass of I¹²⁵ANF added to each tube was evaluated by comparing the displacement achieved with a dose of 320 ng/l ANF 99–126 for a range of final antibody dilutions ($1/1.5$ – 2.4×10^6) when using masses of I¹²⁵ANF ranging from 6 pg/tube to 48 pg/tube. Results (Figure 6.7) show no consistent trend leading to the conclusion that the mass of I¹²⁵ANF, within the range examined, will not improve sensitivity.

Since the primary factors concerned with determining sensitivity have been examined and this assay appears to be inadequate to consider direct measurements in plasma it was decided to attempt to simplify the assay protocol by coupling the primary antibody to magnetic particles. Any minor loss of sensitivity could probably be compensated for by a concentration step prior to assay which would be required in any event.



Figure 6.5 ANF radioimmunoassay: dose response curve.

% Bound

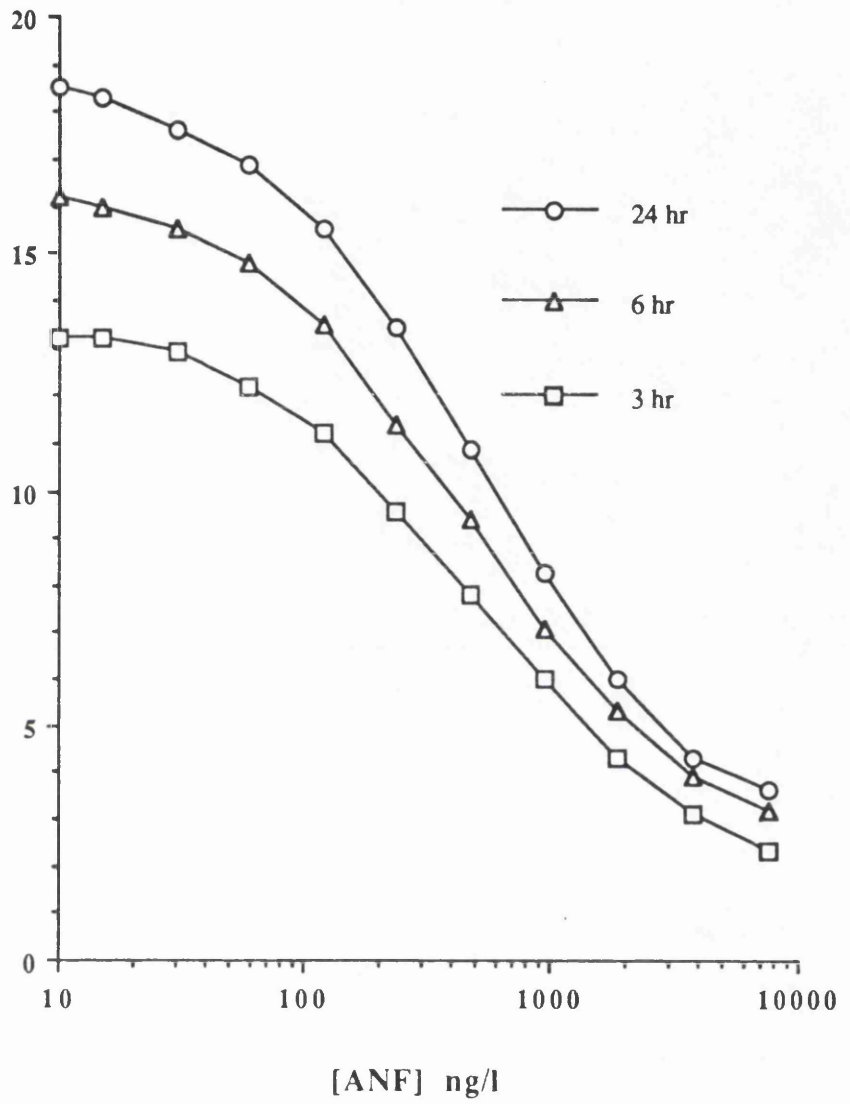

Figure 6.6 The effect of delayed addition of ^{125}I ANF on assay sensitivity.

% Disp

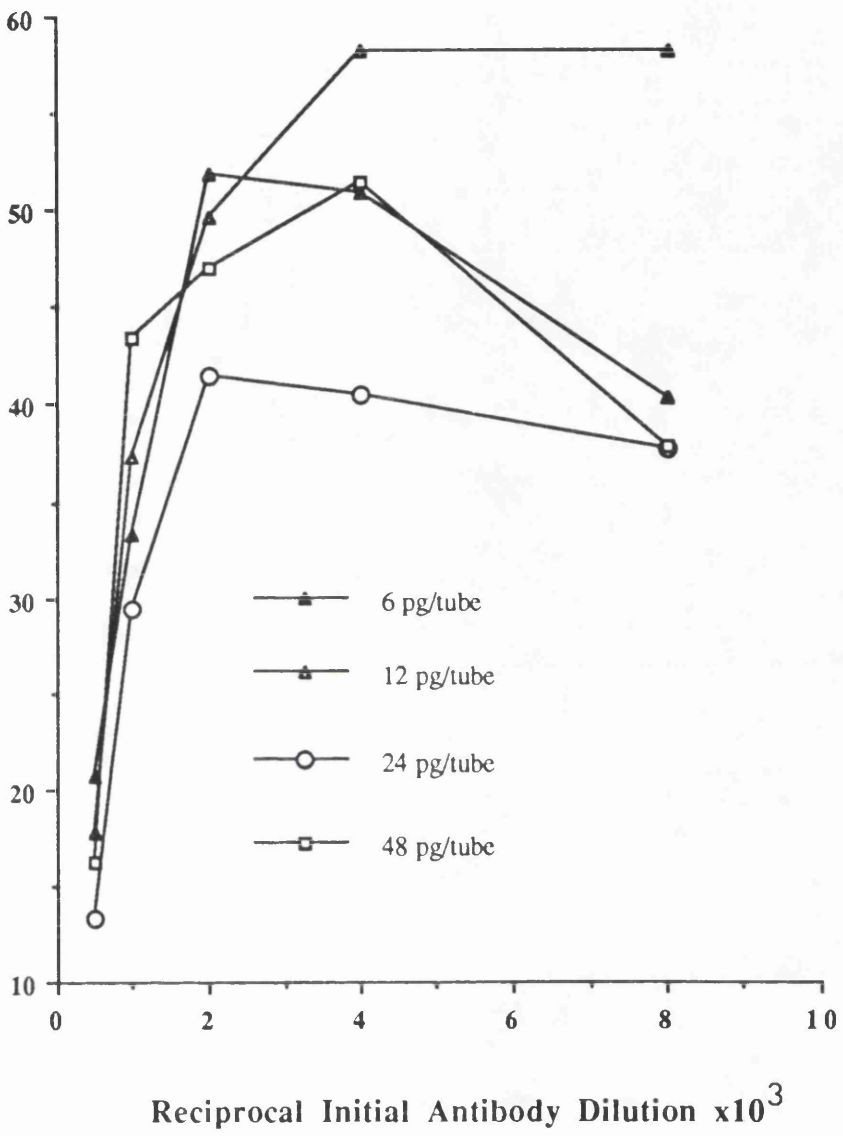

Figure 6.7 The effect of radiolabelled ANF mass on assay sensitivity.

6.4.4 Coupling of Anti-ANF to Magnetic Particles

Dynospheres XP6006 magnetic particles were supplied by Dynal (Norway) as a 10% solids in water suspension. Since the ratio of particles to antibody containing ascitic fluid which would yield the most efficient reagent was not known the coupling experiment was conducted using a fixed mass of particles with dilutions of ascitic fluid in 0.1M phosphate buffered saline (pH 7.4) ranging from x3 to x729. The coupling protocol was as follows :-

200 µl	Dynospheres	(20 mg in water)
50 µl	Ascitic fluid	(Various dilutions)
150 µl	0.1M Phosphate buffered saline	(pH 7.4)
200 µl	0.4M Boric acid	(pH 9.5)

Mix at ambient temperature for 18 hours

1.0 ml	1M Ethanolamine hydrochloride containing 0.1% Tween 20	(pH 9.5)
--------	---	----------

Mix at ambient temperature for 3 hours

Particles were then subjected to two centrifuge/wash cycles with 2 ml of saline and then resuspended in 4 ml of buffer 6 to give a final particle concentration of 0.5 mg/100 µl.

Duplicate aliquots (100 µl) of each preparation were incubated with 200 µl of buffer 6 and 100 µl of I¹²⁵ANF for 18 hours with constant agitation. Particles were then washed with 2 x 1ml of saline using magnetic racks to hold the particles during decantation of supernatants. The bound radioactivity was counted for two minutes. Results (Table 6.3) show good binding for all preparations. The slightly lower binding seen with the x3 preparation may be a steric hindrance effect. Since these binding levels are all approaching maximum it is not possible to draw conclusions concerning coupling efficiency. Further dilutions of x9 to x2187, in assay buffer, of the preparations coupled from initial dilutions of x9, x81 and x729 were therefore prepared and tested in the protocol described above. The dilution

Table 6.3 COUPLING OF ANTI-ANF TO MAGNETIC PARTICLES

Dilution of Ascitic Fluid	% Bound
x3	77.8
x9	88.1
x27	93.2
x81	83.0
x243	91.1
x729	85.6

curves (Figure 6.8) constructed from these results show that coupling at higher concentrations of ascitic fluid causes an increased take up of specific antibody onto the magnetic particles. Figure 6.9 is a further representation of the same data in which the antibody dilution plotted is the product of the coupling dilution of ascitic fluid and the dilution of the final preparation. These curves are essentially superimposable allowing the conclusion that there are no steric hindrance effects.

A 1/16 dilution of the x729 preparation was used in the assay protocol described in section 6.4.1 . This corresponds to 3 µg of XP6006 particles /tube. The resultant dose response curve (Figure 6.10) is comparable in terms of sensitivity to that produced using a liquid phase primary antibody (Figure 6.5). It was decided to use this simpler assay system on concentrated plasma extracts.

6.4.5 Extraction and Concentration of ANF from Plasma

Various methods have been described for the extraction and concentration of ANF from plasma (Table 5.1). Having examined closely the behaviour of ANF on ODS column during the development of a post iodination purification procedure it was decided to utilise Sep-Pak C18 cartridges to extract ANF from plasma.

Sep-Pak C18 cartridges were pre-activated with 5 ml of methanol and washed with 5 ml of distilled water. Plasma samples (4 ml) were acidified with 2M hydrochloric acid (0.25 ml/ml of plasma) prior to application to the cartridges (4 ml). The Sep-Pak cartridges were then washed with 3 x 5 ml of 0.1% trifluoroacetic acid and the absorbed peptide eluted with 2 ml 60% acetonitrile/0.1% trifluoroacetic acid into polypropylene tubes. The extracts were then snap frozen in liquid nitrogen and freeze dried. Immediately prior to assay extracts were reconstituted in 0.5 ml of buffer 6.

The recovery of this method was initially examined by adding 200 µl I^{125} ANF to plasma samples, processing these samples through the extraction procedure and reconstituting the dried extract with 200 µl of buffer 6. Comparison

% Bound

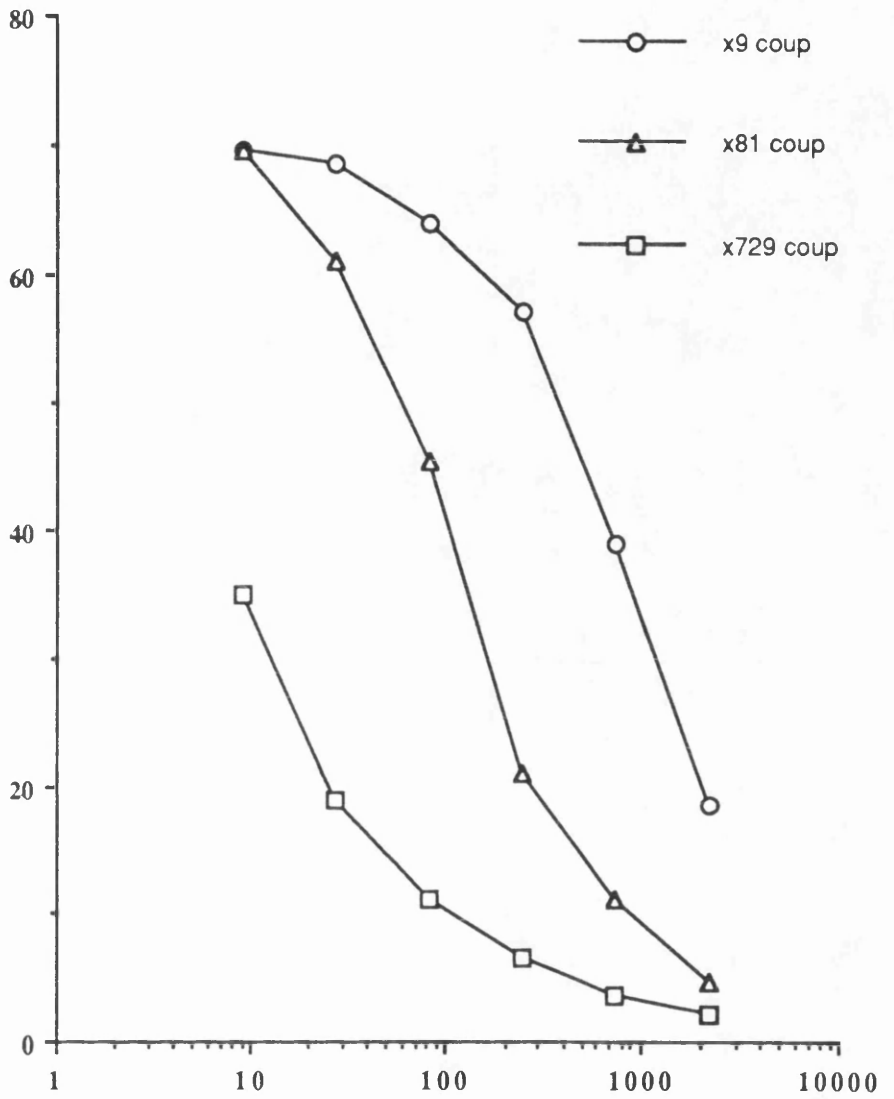

Reciprocal Dilution of SP Preparations

Figure 6.8 Assessment of specific antibody coupling to magnetic particles.

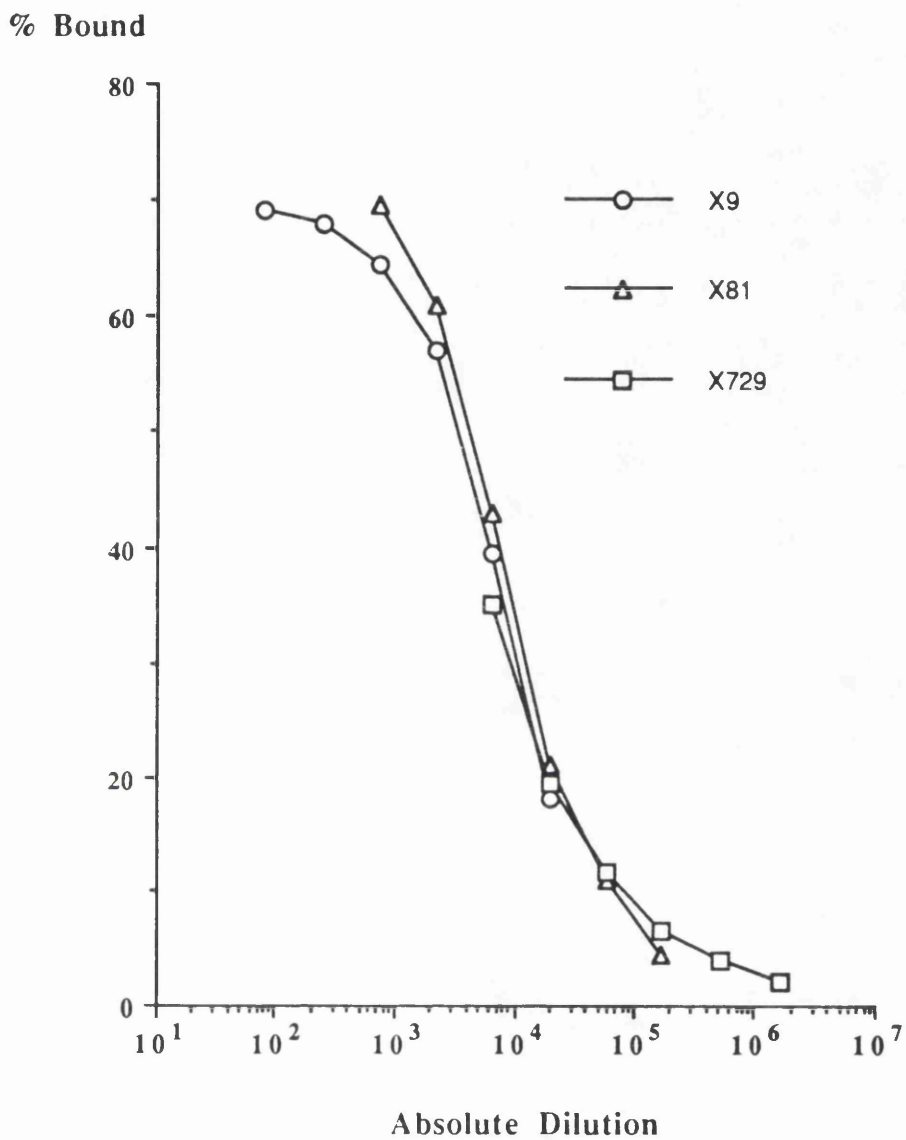

Figure 6.9 Assessment of steric hindrance effect relative to coupling efficiency of anti-ANF to magnetic particles.

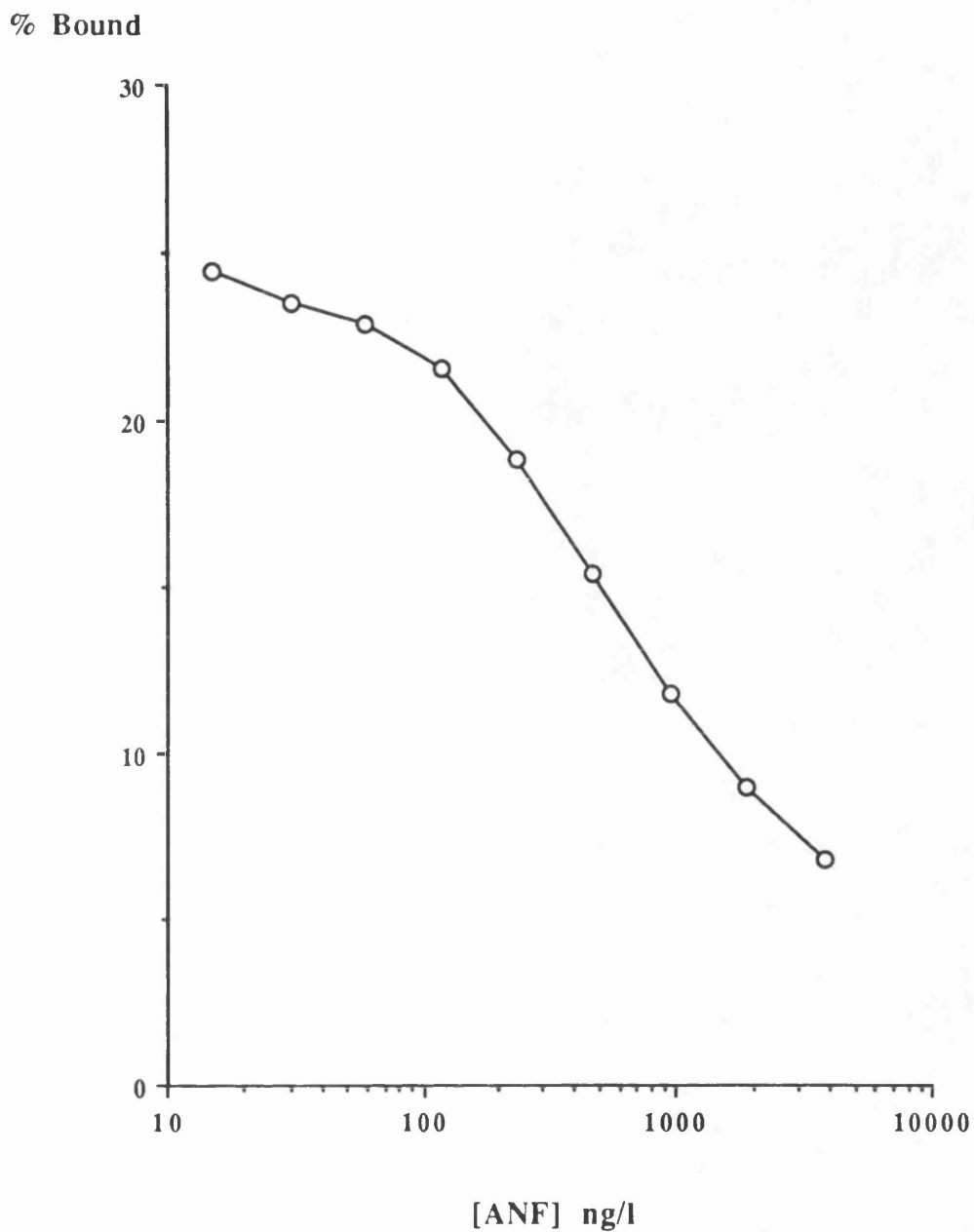

Figure 6.10 ANF radioimmunoassay dose response curve for magnetic particle assay.

of counts added to counts recovered from 10 samples gave a mean recovery of 91%. This experiment took no account of the age of the I¹²⁵ANF used and is therefore likely to be a slight underestimate. Recovery is satisfactory and the procedure introduces a 6.4 fold concentration of ANF.

6.4.6 Recovery of Exogenous ANF from Plasma

Having determined that adequate recovery is obtained from the extraction/concentration procedure it was necessary to combine this procedure with the assay of ANF concentration in the extracts and ascertain the recovery of the total system.

Aliquots (4 ml) of plasma from a "normal" male volunteer were supplemented with synthetic ANF99–126 at three concentrations. These along with a 4 ml aliquot of the original sample were extracted on Sep–Pak C18 cartridges and the extracts assayed by the previously described method. Recovery of exogenous ANF (Table 6.4) was found to range between 90 and 111%. This was considered acceptable. The measured concentration in the basal sample of 203 ng/l however, is high relative to "normal" values cited in the literature. Four possibilities were considered for this apparently elevated basal concentration.

Firstly, the result obtained may be a true reflection of the ANF concentration in this individual. Further basal estimations on five more volunteers ranged between 85 and 150 ng/l. These results were still considered to be elevated.

The remaining three factors were a possible loss of standard potency on storage, differences in the oxidation state of samples and standards, or a cross reacting substance.

6.4.7 Confirmation of Standard Potency

The standard material used in the above recovery experiments was synthetic ANF99–126 supplied by Bachem. Working standards were prepared in

Table 6.4 RECOVERY OF EXOGENOUS ANF FROM PLASMA

	ANF Concentration ng/l	ANF Concentration Corrected for Extraction	% Recovery
Basal	1298	203	-
Basal + 60	2024	268	108.3
Basal + 120	2536	336	110.8
Basal + 240	3165	419	90.0

buffer 6 and stored at -20°C and at the time the experiments were conducted were approximately six months old.

New standards were prepared, from fresh synthetic ANF99–126 supplied by Peninsula Laboratories, covering the range 0–8000 ng/l. Old and new standard preparations were assayed simultaneously and dose response curves constructed (Figure 6.11). These curves indicate that if there is any significant difference the old standards are slightly more potent than the new. This would result in higher concentrations in samples if the new standards were used.

6.4.8 Effect of Oxidation State of Standards and Radiolabelled ANF

a) Avidity of ESA4 anti-ANF for $\text{I}^{125}\text{ANF99-126}$ and $\text{I}^{125}\text{Met}[\text{O}]\text{ANF99-126}$
Since HPLC purification of ANF post iodination isolates mono iodinated oxidised and non oxidised forms it is possible to relate count rate directly to mass if account is taken of the purity and decay characteristics of ^{125}I and the counting efficiency of the gamma counter used. The avidity of ESA4 for $\text{I}^{125}\text{ANF99-126}$ and $\text{I}^{125}\text{Met}[\text{O}]\text{ANF99-126}$ was determined by conducting self displacement experiments with each of these preparations.

Anti-ANF coupled to magnetic particles (100 μl) was incubated with 200 μl of buffer 6 and 100 μl of serial dilutions of each radiolabelled ANF preparation. For each radiolabel dilution duplicate total radioactivity reference tubes were prepared along with non specific binding tubes in which the anti-ANF preparation was replaced with an XP6006 coupled monoclonal anti-TSH antibody. Following an 18 hour incubation, with constant mixing, particles were washed and counted as described in section 6.4.4. Results were used to construct Scatchard plots (Figure 6.12) from which the avidity and the concentration of antibody were estimated. The concentration of antibody in both cases was 9 pmol/l and the avidity constants for $\text{I}^{125}\text{ANF99-126}$ and $\text{I}^{125}\text{Met}[\text{O}]\text{ANF99-126}$ were 6.8×10^{10} l/mol and 1.0×10^{11} l/mol respectively.

% Bound

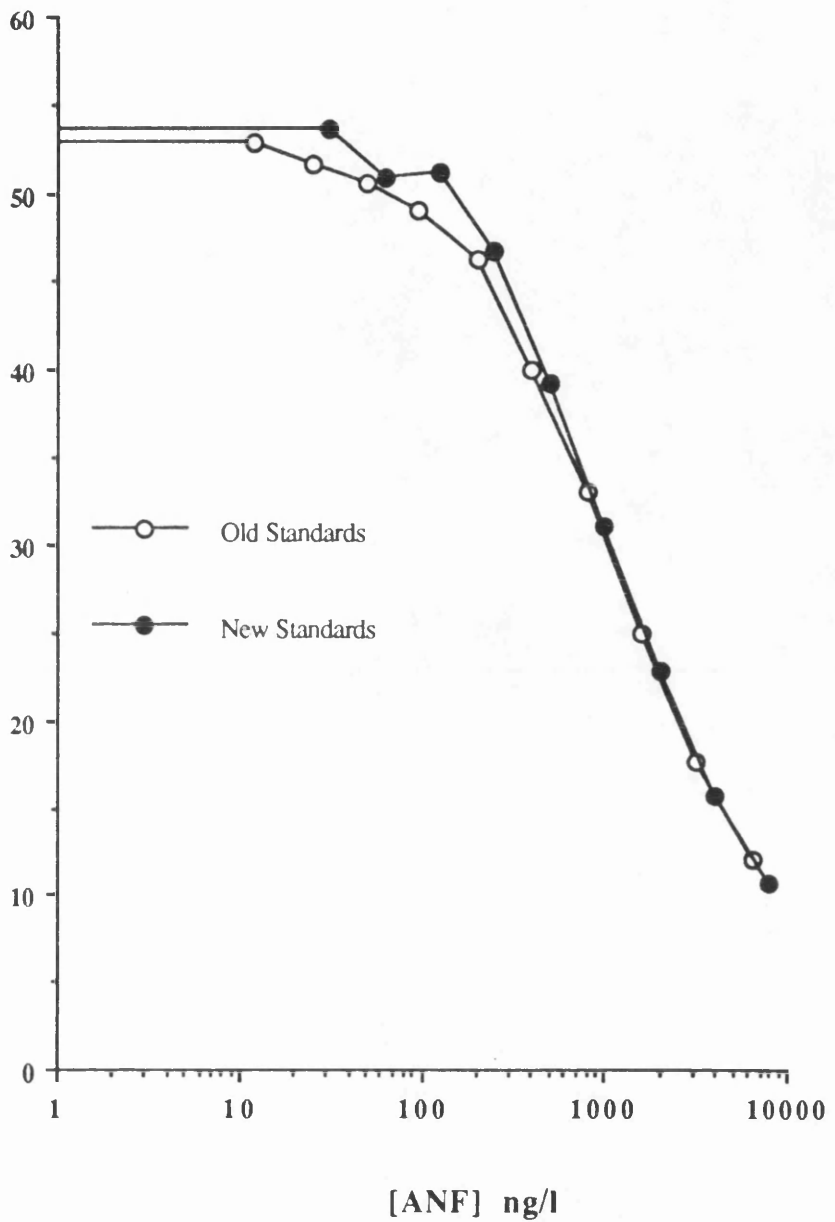

Figure 6.11 Evaluations of ANF standard potency following six months storage at -20°C .

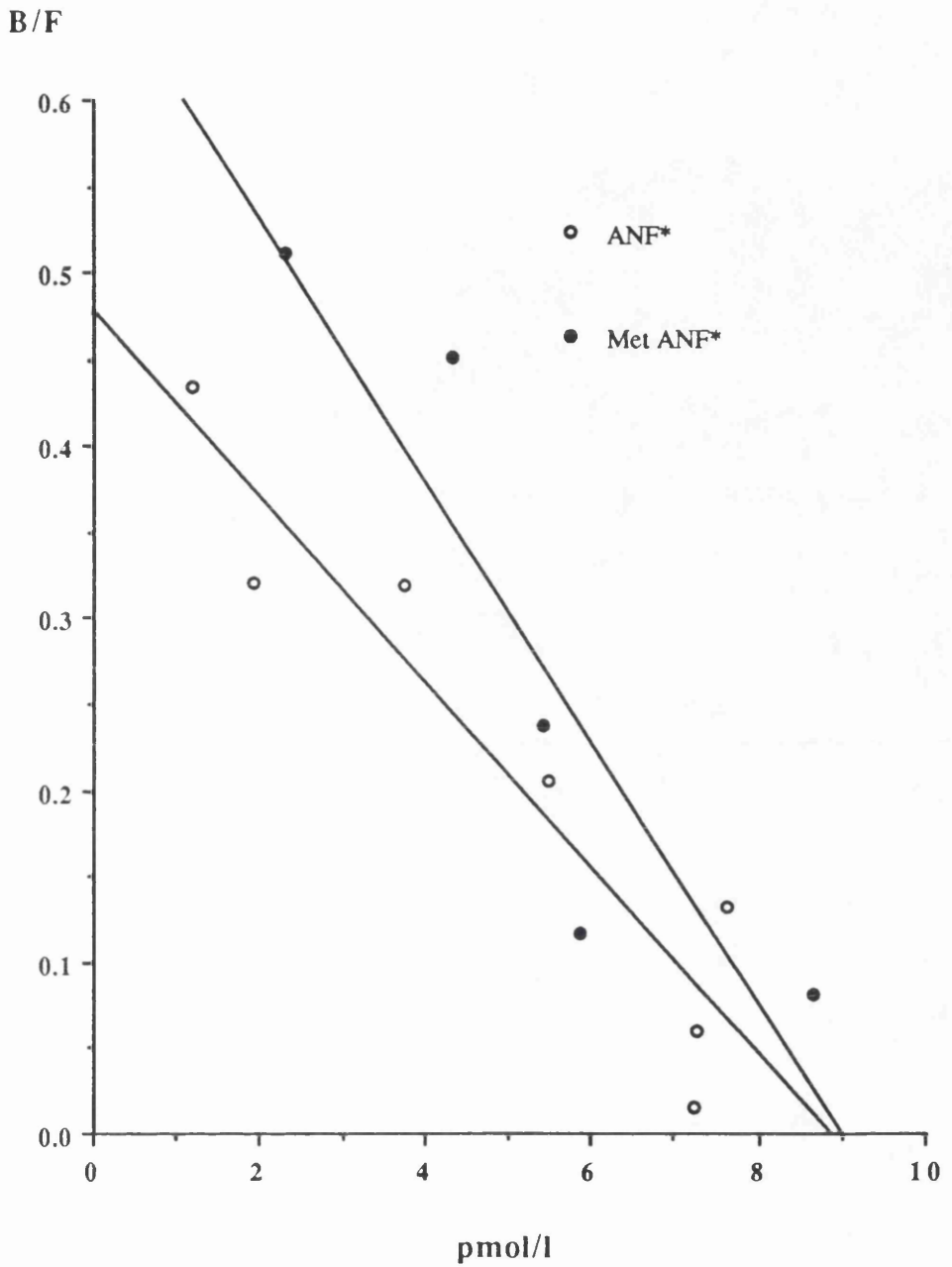

Figure 6.12 Scatchard plots assessing the avidity constants of anti-ANF (ESA4) for ^{125}I ANF 99-126 and ^{125}I Met[O] ANF 99-126.

b) Comparison of Met[O]ANF99–126 and ANF99–126 Standard Preparations.

Synthetic Met[O]ANF 99–126 supplied by Peninsula Laboratories was used to prepare standards over the range 0–8000 ng/l. These and ANF 99–129 standards were assayed simultaneously, I¹²⁵ANF 99–126 being used as the radiolabel. The dose response curves obtained (Figure 6.13) suggests that the Met[O]ANF 99–126 standards are slightly more potent. This is consistent with the small difference in avidity constants derived in the previous experiment.

If the ANF 99–126 standard is totally oxidised on storage this could give a 25% lower estimate of the basal concentrations in plasma. This magnitude of difference would still leave basal concentrations high relative to published data.

6.4.9 Further Examination of Plasma Extraction Procedure

Previous experiments have indicated that the recoveries of I¹²⁵ ANF from the Sep–Pak columns, and exogenous ANF from plasma processed through the total assay procedure are acceptable. Basal concentrations of ANF however appear to be elevated relative to published data. Since standard potency has been confirmed and differences in sample/standard/radiolabel oxidation states found not to account for these apparently elevated concentrations the possibility of a cross reacting substance was considered. The presence of a cross reactant would invalidate the assay unless it could be removed by the initial extraction procedure. This was therefore examined within this context.

Eight aliquots of acidified plasma (4 ml) from a single volunteer were subjected to Sep–Pak extraction as described in section 6.4.5 each aliquot however being eluted from the column with a different concentration of acetonitrile in 0.1% trifluoroacetic acid (range 15–60%). Eluents were snap frozen, freeze dried, reconstituted and assayed as previously described.

A simultaneous experiment was conducted in which I¹²⁵ ANF was added

% Bound

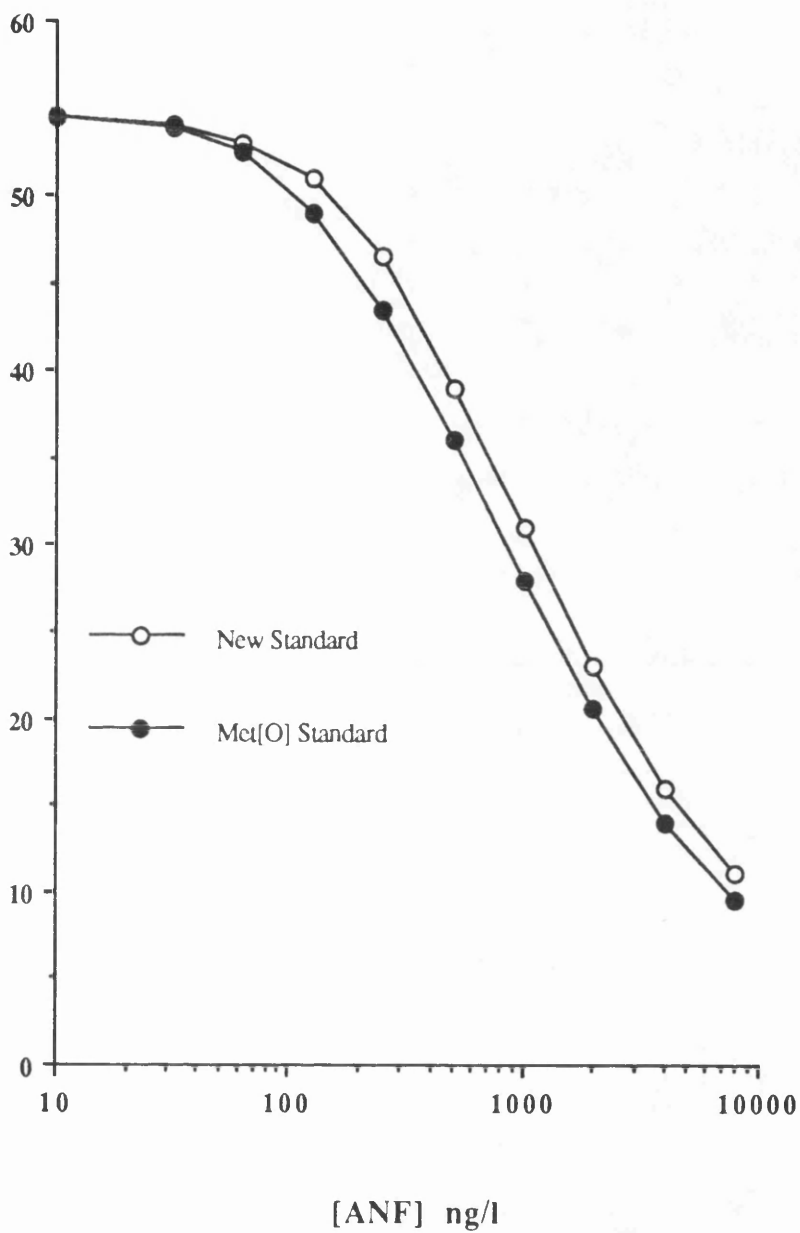

Figure 6.13 Comparison of Met[O] ANF 99-126 and ANF 99-126 standards.

to a 40 ml aliquot of the same plasma sample and aliquots of this (8 x 4 ml of acidified plasma) extracted as above. Aliquots (200 μ l) of column eluents were counted for 120 seconds and the recovery of I^{125} ANF calculated for each concentration of acetonitrile used for elution from the column.

The results of these two experiments are presented together in Figure 6.14. The recovery of I^{125} ANF reaches a plateau of approximately 84% at acetonitrile concentrations in excess of 35%. Plasma ANF concentration also reaches a plateau at this concentration of acetonitrile, however a further rise in plasma concentration is seen as the acetonitrile concentration exceeds 50%. These experiments suggest a substance other than ANF is extracted from plasma and eluted from Sep-Pak columns at concentrations of acetonitrile in excess of 50%. Modification of the extraction procedure would eliminate this cross reactant.

6.5

CONCLUSIONS

The five antibodies examined did not provide a complementary pair suitable for use in a two-site immunometric assay. While the affinity of the monoclonal antibody ESA4 was not sufficient to allow consideration of a direct radioimmunoassay it has been demonstrated to be suitable for use in an indirect assay. There is some indication that this antibody is not absolutely specific but that this problem can be overcome by careful design of the extraction /concentration procedure prior to radioimmunoassay.

The major cause for concern is the variability of estimations on "normal" individuals, and the apparently high concentrations relative to published data. Further detailed examinations of sampling and storage conditions and the parameters of the extraction/ concentration procedure are required. This in conjunction with assessment of the effects of physiological sources of variation, biological rhythm, dietary status and posture will clarify the situation.

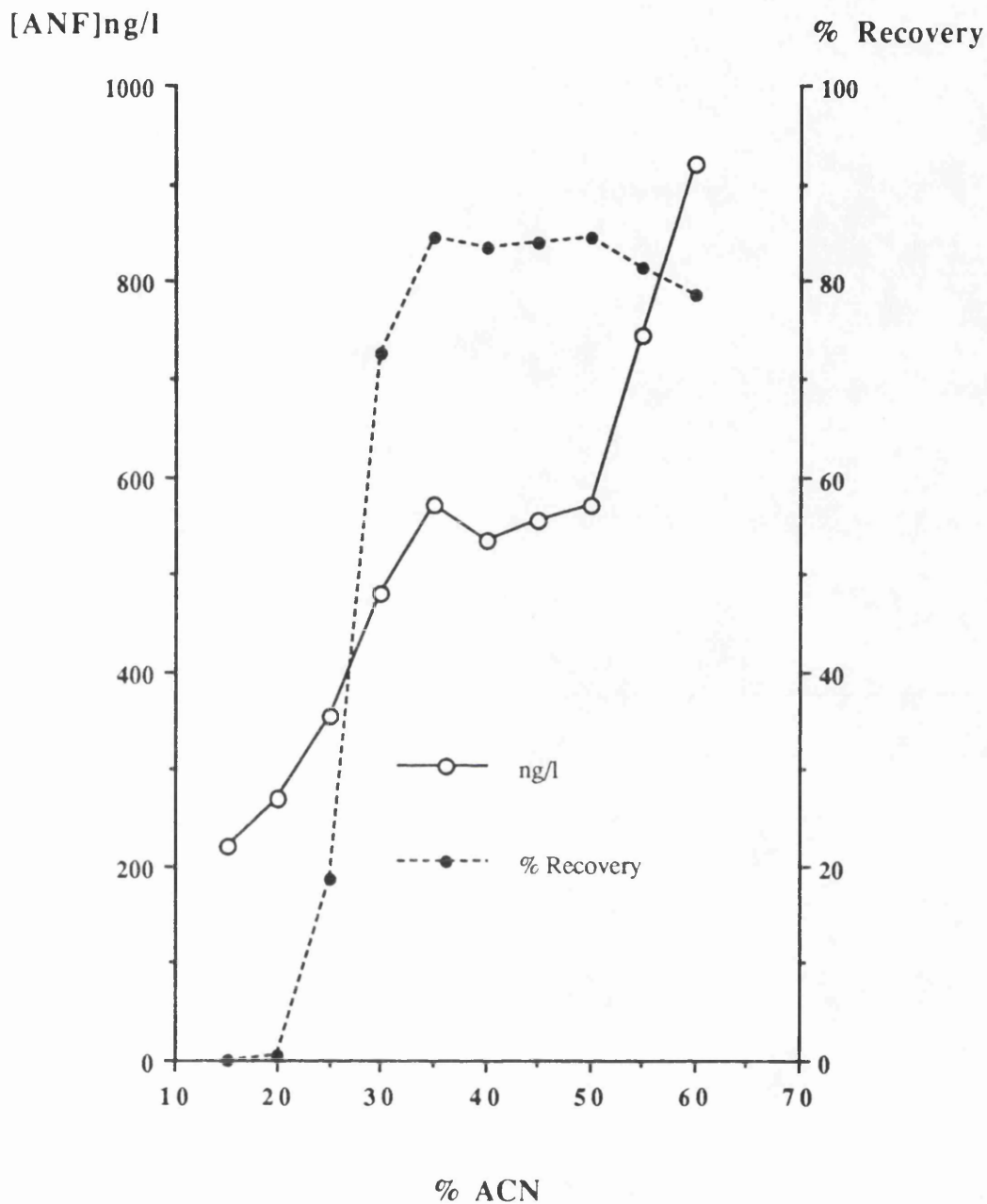

Figure 6.14 Evaluation of the effects of acetonitrile concentration on the elution of ANF from Sep-Pak ODS cartridges.

CHAPTER 7

GENERAL DISCUSSION

This thesis relates the strategies and tactics in applying the new technology of monoclonal antibody production to the provision of a routine diagnostic endocrinology service. The objectives outlined in Chapter one reflect the initial baseline within the Institute of Biochemistry where no tissue culture facilities were available and there was no expertise in this area. Consequently the stated objectives were broad.

It is axiomatic that the key component of an immunoassay system is the antibody (or antibodies). Though other factors such as the choice of label or method of separation may be important, it is the antibody which will ultimately determine the performance characteristics of the system. Given that a monoclonal antibody with the required characteristics can readily be produced it is generally true that this would be preferred to a polyclonal reagent. Considerable efforts have been applied to the production of monoclonal antibodies to peptide and protein hormones in a variety of centres yet in reality the introduction of monoclonal antibodies into diagnostic immunoassay systems has been relatively slow. The reasons for this are both practical and economic. While the principles of monoclonal antibody production are elegantly simple the practice is an enormous undertaking, particularly so if the end point is seen as the incorporation of a new assay into a diagnostic service and not merely the production of an antibody. Within this context each project will have its unique problems. These may be related to the structure of the analyte or the physiological and pathophysiological environment in which the analyte is encountered in routine clinical practice. The approaches adopted in attempting to produce and apply monoclonal antibodies to the measurement of growth hormone, parathyroid hormone and atrial natriuretic factor reflect that uniqueness.

Having a clinical biochemistry background it seemed at the outset that the development of a tissue culture facility and protocols for cell fusion and hybrid propagation would be the most significant problem. While the scale of this

development should not be underestimated the technical aspects of the process proved to be relatively simple. In the three cases examined hybridomas were always successfully generated. In fact the number of hybrids produced caused logistical problems in screening large numbers for specific antibody production. This was particularly so in the case of growth hormone.

Growth hormone because of the phylogenetic distance between human GH and mouse GH was a particularly good immunogen. This and the sensitivity of the screening assay procedure resulted in the production of more anti-GH secreting hybrids than could practically be coped with. While this could be considered a success it can also be construed as a failure in that this could have been anticipated and a more stringent initial screening procedure adopted. The ideal requirements for anti-GH monoclonal antibodies to be used in a two-site assay apart from the obvious requirement of the highest possible affinity would include a lack of cross reaction with similar proteins i.e. prolactin and human placental lactogen. Selectivity at this stage would significantly reduce subsequent workload and would ensure that effort and resources were not wasted on antibodies of no value to the project at hand. Circular arguments exist as to whether affinity or specificity is of most importance in this initial selection process. Obviously there is little point in selecting the two most avid antibodies if they both cross react with the same alternative molecule. However only one antibody in a two-site assay needs to be entirely specific since assay design considerations can often overcome potential cross reaction problems. This is well illustrated in the case of PTH 1-84 being measured in the presence of C-terminal PTH fragments. The developed growth hormone assay proved to be precise, accurate and robust offering a significant extension of working range in comparison to radioimmunoassays. The clinical discrimination from this assay was at least equal to the RIA it replaced. The only disadvantage is the cross reaction in this assay system with placental lactogen and to a small degree prolactin. The extent of cross reaction was evaluated by means of

recovery estimates of added exogenous growth hormone from sera containing elevated endogenous concentrations of potential cross reactant. Perry *et al* (1991) illustrate the problems associated with the assessment of cross reactivity and or interference utilising this growth hormone assay as a model.

The need to measure PTH1–84 in the presence of significant concentrations of C-terminal fragments was known at the outset. This led to the use of synthetic fragments as immunogens to produce the desired specificity of resultant monoclonal antibodies. Since the early work of Lerner (1982) and Schmitz *et al* (1983) it is now well established that small peptide sequences can be used to produce antibodies to the intact protein of which they form a part. This approach frequently produces peptide specific antibodies which fail to react with the native molecule (Lerner, 1984) as was the case in this study. However three of the five antibodies isolated did recognise the native molecule.

While the numbers initially screened in the cases of PTH and ANF were large since few specific antibody secreting hybrids were found secondary evaluations were more manageable. The number of specific anti-PTH antibodies detected on initial screening was a little surprising in view of the high titres found in the sera of donor rats. The products of fusion did not reflect the state of immunisation of the spleen donor. A satisfactory explanation for this was not immediately obvious though subsequent work with ANF did suggest a possible source of variability in the screening assay. Detailed evaluation of the radioiodination and post iodination purification of ANF revealed a sensitivity of some antibodies to the oxidation state of the only methionine residue in the molecule. There is also evidence of variable degrees of oxidation as a consequence of variation in iodination methods and or conditions. Parathyroid hormone 1–34 contains methionine residues at positions 8 and 18 and is therefore likely to be prone to the same effects. Tashjian *et al* (1964) have shown these methionine residues to be susceptible to oxidation on storage under acid conditions and that

polyclonal antisera to N-terminal PTH can be sensitive to the oxidation state of PTH. Recent studies using circular dichroism have confirmed that the oxidation of the methionine residue, at position 8 particularly, produces substantial changes in the secondary structure of PTH 1–34. These changes alter the conformation of the PTH 1–34 peptide, resulting in reduced affinity for receptors (Zull et al, 1990). The ^{125}I -PTH utilised in the screening assays for anti-PTH was purified by gel filtration only and was therefore likely to be a heterogeneous product.

The evaluation of the radioiodination and post iodination purification of ^{125}I -ANF while being a key part of the assessment of the screening assay for anti-ANF antibodies allowed two further more general observations. The calculation of specific radioactivity of radioiodinated peptides generally assumes that all peptide/protein molecules exposed to the reaction incorporate ^{125}I . The experiments detailed in Chapter five clearly show that this is not the case. Reduction of the molar concentration of chloramine T in iodination reactions to levels similar and below those utilised in the lactoperoxidase iodination method did not produce similar peptide oxidation profiles. This could suggest differing mechanisms of reaction. Perhaps the controlled release of oxidant from hydrogen peroxide over an extended reaction period ensures that the concentration of oxidant remains very low in comparison to the short exposures with chloramine T.

Apart from the logistical problems of screening assays the use of KLH conjugated peptides also presented difficulties. KLH being a potent immunogen illicit an immune response which can saturate the capacity of a solid-phase separation screening assay. This effect is variably dependent upon anti-KLH titres and titres of specific peptide antibody and is therefore more likely to be a significant problem when attempting to produce antibodies to poor immunogens. ANF was a particularly poor immunogen. In retrospect the choice of KLH as a carrier protein was unwise. The majority of workers who have successfully produced monoclonal antibodies to ANF have used thyroglobulin as a carrier

protein and immunised balb/c mice.

In the studies with PTH 1–34 and ANF immune responses appeared to be strain specific. PTH 1–34 antibodies were only demonstrated in DA rats and ANF antibodies in NZB\balbc F1 hybrid mice. This is in keeping with current theories on MHC restriction. Nussbaum *et al* (1985) in relation to PTH 1–34 illustrated a genetic control of the immune response. The H–2 complex of the mouse consisting of genes controlling multiple functions can be divided into K, I, S and D regions. I region genes control the immune response and also code for Ia surface molecules on macrophages and B cells. These Ir genes appear to operate at the level of the macrophage by a process of determinant selection. The I region can be further subdivided into five subregions, A, B, J, E and C. Immunoresponse genes have been identified in IA and IE subregions. The studies of Nussbaum *et al* demonstrate the importance of the choice of mouse strain for immunisation in the development of monoclonal antibodies. The choice of nonresponder mouse strains may explain unsuccessful attempts to raise high affinity monoclonal antibodies in many laboratories. The logical practical approach to raising monoclonal antibodies would be to immunise as many immunologically diverse inbred mouse strains as possible selecting only those with high peripheral titre for fusion.

The high titre response to PTH 1–34 allowed successful specific antibody secreting hybridoma production and isolation and the subsequent development of an assay capable of quantifying concentrations of 1–84 PTH in plasma. The assay compares favourably in terms of detection limit and working range to published assays for intact PTH 1–84 (Nussbaum *et al*, 1987; Brown *et al*, 1987; Frolich *et al*, 1990). The validation studies show that this assay system gives quantitative recovery of exogenous PTH 1–84. The tolerance of a 200 fold molar excess of C–terminal fragments in the optimised assay will prevent interference from samples from patients with established renal failure where gross elevations of C–terminal fragments can occur. The level of interference from PTH 1–34 is unlikely to be a

problem in clinical samples as recent evidence indicates that circulating concentrations of PTH 1–34 are low (Bringham et al, 1988). The main clinical application of PTH 1–84 assay is the differential diagnosis of hypercalcaemia. The PTH 1–84 results from this assay allow good discrimination between normal subjects and patients with primary hyperparathyroidism. The PTH 1–84 concentrations in patients with hypercalcaemia of malignancy were well separated from those with primary hyperparathyroidism with most patients with malignancy having undetectable PTH 1–84 concentrations.

The process of developing a radioimmunoassay for the measurement of ANF concentration, while incomplete, illustrates some of the reasons for the diversity of reference ranges quoted in the literature. The choice of iodination method, extraction procedure and standard material combined with antibody specificity have all been shown to be problematical.

Several alternative strategies have been employed in attempts to improve the success rate of the monoclonal antibody production process. These strategies have been aimed at different areas of the process. Spitz et al (1984) described a process of intrasplenic immunisation designed to give a high localised concentration of antigen in the target organ. This procedure supposedly offered the advantage of maximising the number of specific B cell blasts in the spleen and minimising the uptake and elimination of antigen in other parts of the body. Borrebaeck (1983) reported a technique of *in vitro* immunisation. This procedure utilises the medium from a mixed lymphocyte culture to provide growth factors and soluble factors which mimic those produced by T cell helper cells thus transforming non-immune spleen cells into blast cells when exposed to antigen. The procedure is described as offering several advantages over standard techniques in that only a few micrograms of antigen are needed; it is possible to follow visually the induction of blast cells; the immunisation takes only four to five days; and importantly, the normal cellular control of the immune response to self-antigens seems not to function in culture.

This latter factor may enable the induction of responses *in vitro* to highly conserved antigens which prove difficult *in vivo*. As an alternative to chemical and viral fusogens Vienken and Zimmermann (1982) have described an electrofusion technique. Electrofusion is based on the temporary permeabilisation of the cell membrane in response to electrical breakdown. This phenomenon was discovered in 1973 (Zimmermann et al) and was first used for the electroinjection of membrane-impermeable substances into freely suspended cells without deterioration of cellular functions or membrane integrity. Lo et al (1984) attempted to overcome the poor efficiency and randomness of polyethylene glycol fusion techniques by using a receptor mediated electrically induced cell fusion technique. B-cells express on their surface antigen receptor immunoglobulins of the same antigenic specificity as the secreted antibodies. Binding of antigen to surface immunoglobulins stimulates proliferation and differentiation of B-cells into plasma cell. Antigen covalently conjugated to avidin binds to the surface immunoglobulins on B-cells. This B-cell-antigen-avidin complex binds to biotin covalently attached to the surface of myeloma cells. An intense electric field across the bulk suspension then produces selective fusion of cells in contact, that is, of myeloma cells with B-cells which make the appropriate antibody. The net effect is that the majority of resultant hybridomas secrete appropriate antibodies. The advantages of this technique are that there is selection of high affinity antibodies because of the antigen directed fusion and that there is a reduction in the total numbers of hybrids produced but that those which do grow are more likely to be secreting antibody of interest thus reducing the demands on screening time.

These alternative techniques have not yet found widespread favour though it can be seen that several of the major problems of the basic procedure could be overcome by the further development of *in vitro* immunisation and chemically mediated electrofusion. The combination of these techniques could be used to reduced MHC restriction problems and remove the need for a primary screening

system identifying specific antibody secreting hybrids thus reducing a major logistical problem. A further interesting development is the genetic manipulation of the variable, antigen binding, regions of immunoglobulin molecules which may prove to be an alternative strategy for the production of monoclonal antibodies.

The aims of this thesis have largely been fulfilled. Techniques for the production of monoclonal antibodies have been established and used for the production of antibodies to both peptide and protein hormones. Selected antibodies have been utilised in the the development of immunoassays and these assays analytically and clinically validated. Many of the problems of the overall process have been highlighted and their solutions illustrated. Monoclonal antibodies will continue to play a key role in the future development of analytical services providing assays with improved specificity, sensitivity and speed thus increasing clinical utility.

REFERENCES

Abe, M. & Sherwood, L.M. (1972). Regulation of parathyroid hormone secretion by adenyl cyclase. Biochemical and Biophysical Research Communications, 48, 396–401.

Addison, G.M. Hales, C.N., Woodhead, J.S. & O'Riordan, J.L.H. (1971). Immunoradiometric assay of parathyroid hormone. Journal of Endocrinology, 49, 521–530.

Almeida, F.A., Suzuki, M. & Maack, T. (1986). Atrial natriuretic factor increases hematocrit and decreases plasma volume in nephrectomized rats. Life Sciences, 39, 1193–1199.

Arendt, R.M., Stangl, E., Zähringer, J., Liebisch, D.C. & Herz, A. (1985). Demonstration and characterisation of α -human atrial natriuretic factor in human plasma. Federation of European Biochemical Societies Letters, 189, 57–61.

Arendt, R.M., Gerbes, A.L., Ritter, D. & Stangl, E. (1986). Molecular weight heterogeneity of plasma-ANF in cardiovascular disease. Klinische Wochenschrift, 64 (suppl. 6), 97–102.

Arendt, R.M., Gerbes, A.L., Ritter, D., Stangl, E., Bach, P. & Zähringer, J. (1986^b). Atrial natriuretic factor in plasma of patients with arterial hypertension, heart failure or cirrhosis of the liver. Journal of Hypertension, 4 suppl.2, S131–S135.

Arnaud, C.D., Goldsmith, R.S., Bordier, P.J. & Sizemore, G.W. (1974). Influence of immunoheterogeneity of circulating parathyroid hormone on results of radioimmunoassay in man. American Journal of Medicine, 56, 785–793.

Ashby, J.P. & Newman, D.J. (1988). Clinical and laboratory evaluation of a two-site immunoradiometric assay for intact parathyroid hormone. Annals of Clinical Biochemistry, 25, 654–660.

Atarashi, K., Mulrow, P.J., Franco-Saenz, R. & Rapp, J. (1984). Inhibition of aldosterone production by an atrial extract. Science, 224, 992–994.

Atlas, S.A., Kleinert, H.D., Carmargo, M.J., *et al* (1984). Purification, sequencing and synthesis of natriuretic and vasoactive rat atrial peptide. Nature, 309, 717–719.

Bahlmann, J., McDonald, J.S., Ventom, M.G. & de Wardner, H.E. (1967). The effect on urinary sodium excretion of blood volume expansion without changing the composition of the blood. Clinical Science, 32, 403–413.

Ballerman, B.J., Hoover R.L., Karnovsky M.J. & Brenner, B.M. (1985). Physiological regulation of atrial natriuretic peptide receptors in rat renal glomeruli. Journal of Clinical Investigation, 76, 2049–2056.

Ballerman, B.J. (1987). A highly sensitive radioreceptor assay for atrial natriuretic peptide in rat plasma. In: The American Society of Hypertension, Second World Congress on Biologically Active Atrial Peptides, pp 208.

Bancroft, F.C., Sussman, P.M. & Tushinski, R.J. (1976). In: Growth Hormone and Related Peptides, ed Pecile, A. & Müller, E.E., pp 84–93. Amsterdam: Excerpta Medica.

Bauman, G. (1988). Growth hormone binding proteins and heterogeneity of secreted growth hormone. Abstract : S136, 8th International Congress of Endocrinology, Kyoto, Japan.

Benacerraf, B. & McDevitt, H.O. (1972). Histocompatibility–linked immune response genes. Science, 175, 273–279.

Bersofsky, J.A. (1985). Intrinsic and extrinsic factors in protein antigenic structure. Science, 229, 932–940.

Berson, S.A., Yalow, R.S., Aurbach, G.D. & Potts, J.T. (1963). Immunoassay of bovine and human parathyroid hormone. Proceedings of the National Academy of Science USA, 49, 613–617.

Berson, S.A. & Yalow, R.S. (1968). Immunochemical heterogeneity of parathyroid hormone in plasma. Journal of Clinical Endocrinology and Metabolism, 28, 1037–1047.

Bianchi, C., Gutkowska, J., Thibault, G., Garcia, R., Genest, J. & Cantin, M. (1985). Radioautographic localisation of I¹²⁵ atrial natriuretic factor in rat tissues. Histochemistry, 82, 441–452.

Blind, E., Schmidt-Gayk, H., Armbruster, F.P. & Stadler, A. (1987). Measurement of intact human parathyrin by an extracting two-site immunoradiometric assay. Clinical Chemistry, 33, 1376–1381.

Bold De, A.J., Raymond, J.J. & Bencosme, S.A. (1978). Atrial specific granules of the rat heart: light microscopic staining and histochemical reactions. Journal of Histochemistry and Cytochemistry, 26, 1094–1102.

Bold De, A.J. (1979). Heart atria granularity effects of changes in water electrolyte balance. Proceedings of the Society for Experimental Biology and Medicine, 161, 508–511.

Bold De, A.J., Borenstein, H.B., Veress, A.T. & Sonnenberg, H. (1981). A rapid and potent natriuretic response to intravenous injection of atrial myocardial extracts in rats. Life Sciences, 28, 89–94.

Bompiani, G.D., Rouiller, C. & Hatt, P.Y. (1959). Le tissu de conduction du coeur chez le rat. Etude au microscope électronique. Archives Maladies Coeur et Vaisseaux, 52, 1257–1267.

Borrebaeck, C.A.K. (1983). In vitro immunization for the production of antigen-specific lymphocyte hybridomas. Scandinavian Journal of Immunology, 18, 9–12.

Bosch, A.M.G., Stevens, W.J., Schuurs, A.H., Schonherr, O. & Roelofs, H. (1982). Characteristics of monoclonal antibodies against human chorionic gonadotrophin. Protides of the Biological Fluids, 29, 837–842.

Brewer, H.B., Fairweel, T., Ronan,R., Rittel, W. & Arnaud, C. (1975). Human parathyroid hormone. In: Calcium Regulating Hormones, ed. Talnage, R.V., Owen, M. & Parsons, J.A., pp 23. Amsterdam : Excerpta Medica.

Bringhurst, F.R., Stern, A.M., Yotts, M., Neptune, M., Segre, G.V. & Potts, J.T. Jr (1988). Peripheral metabolism of PTH: fate of biologically active amino terminus *in vivo*. American Journal of Physiology, 255, E886–E893.

Brown, R.C., Aston, J.P., Weeks, I. & Woodhead, J.S. (1987). Circulating intact parathyroid hormone measured by a two–site immunochemiluminometric assay. Journal of Clinical Endocrinology and Metabolism, 65, 407–414.

Bucheggar, F., Accolla, R.S., Carrel, S., Carmagnola, A., Girardet, C. & Mach, J.P. (1981). Use of monoclonal anti–CEA antibodies in immunoabsorbent columns and solid–phase radioimmunoassay. Protides of the Biological Fluids, 28, 511–515.

Buckle, R.M., Care, A.D., Cooper, C.W. & Gitelman, H.J. (1968). The influence of plasma magnesium concentration on parathyroid hormone secretion. Journal of Endocrinology, 42, 529–534.

Bundesen, P.G. , Drake, R.G. *et al* (1980). Radioimmunoassay for human growth hormone using monoclonal antibodies. Journal of Clinical Endocrinology and Metabolism, 51, 1472–1474.

Burgisser, E., Raine, A.E.G., Erne, P., Kamber, P. & Buhler, F.R. (1985). Human cardiac plasma concentrations of atrial natriuretic peptide quantified by radioreceptor assay. Biochemical and Biophysical Research Communications, 13, 1201–1209.

Burnet, F.M. (1959). The clonal selection theory of acquired immunity. Cambridge:University Press.

Burnett, J.C., Kao, P.C., Hu, D.C. *et al* (1986). Atrial natriuretic peptide elevation in congestive heart failure in the human. Science, 231, 1145–1147.

Campbell, A.M. (1984). Monoclonal Antibody Technology. Amsterdam : Elsevier.

Cantor, H., Shen, F.W. & Boyse, E.A. (1976). Separation of helper T cells from suppressor T cells expressing different Ly components. II Activation by antigen : after immunisation, antigen-specific suppressor and helper activities are mediated by distinct T-cell subclasses. Journal of Experimental Medicine, 143, 1391-1401.

Chapman, R.S. & Ratcliffe, J.G. (1981). Covalent linkage of antisera to microparticulate cellulose using 1-carbodiimidazole : a rapid and practical method which might be useful for the solid-phase radioimmunoassay of thyroxine. Clinica Chimica Acta, 118, 129-134.

Chawla, R. K., Parks, J.S. & Rudman, D. (1983). Structural variants of human growth hormone : biochemical, genetic, and clinical aspects. Annual Review of Medicine , 34 , 519-547 .

Chou, P.Y. & Fasman, G.D.(1974^a). Conformational parameters for amino acids in helical, β -sheet and random coil regions from proteins. Biochemistry, 13, 211-222.

Chou, P.Y. & Fasman, G.D. (1974^b). Prediction of protein conformation. Biochemistry, 13, 222-245.

Chou, P.Y. & Fasman, G.D. (1977). β -turns in proteins. Journal of Molecular Biology, 115, 135-175.

Chu, L.L.H., MacGregor, R.R., Anast, C.S., Hamilton, J.W. & Cohn, D.V. (1973). Studies on the biosynthesis of rat parathyroid hormone and proparathyroid hormone : adaption of the parathyroid to dietary restriction of calcium. Endocrinology, 93, 915-924.

Coffino, P., Baumal, R., Laskov, R. & Scharff, M.D. (1972). Cloning of mouse myeloma cells and detection of rare variants. Journal of Cell Physiology, 79, 429-440.

Cohn, D.V., MacGregor, R.R., Sinha, D., Huang, D.W.Y., Edelhoich, H. & Hamilton, J.W. (1974). The migration behaviour of parathyroid hormone, parathyroid hormone, and their peptide fragments during gel filtration. Archives of Biochemistry and Biophysics, 164, 669–673.

Cohn, D.V. & MacGregor, R.R. (1981). The biosynthesis, intracellular processing, and secretion of parathormone. Endocrine Reviews, 2, 1–26.

Cole, B.R. & Needleman, P. (1985). Atriopeptins : volume regulatory hormones. Clinical Research , 33, 389–394.

Collins, W.P., Barnard, G.J., Kim, J.B., Weerasekera, D.A., Kohen, F., Eshhar, Z. & Linder, H.R. (1983). Chemiluminescence immunoassays for plasma steroids and urinary steroid metabolites. In : Immunoassays for Clinical Chemistry, ed. Hunter, W.M. & Corrie, J.E.T., pp 373–397. Edinburgh : Churchill Livingstone.

Currie, M.G., Geller, D.M., Cole, B.R. *et al* (1984). Purification and sequence analysis of bioactive atrial peptides (atriopeptins). Science, 223, 67–70.

Daughaday, W. H. (1985). In Williams Textbook of Endocrinology , ed. Wilson, J.D. & Foster, D.W., 7th edn. , Ch. 18, pp 568–613. Philadelphia : Saunders.

Denoto, F., Moore, D.D. & Goodman, H.M. (1981). Human growth hormone DNA sequence and mRNA structures : possible alternative splicing. Nucleic Acids Research, 9, 3719–3730.

Dietz, J.R. (1984) Release of natriuretic factor from rat heart–lung preparation by atrial distension. American Journal of Physiology, 247, R1093–1096.

Dzau, V.J., Baxter, J.D., Cantin, M. *et al* (1987). Nomenclature for atrial peptides. New England Journal of Medicine, 316, 1278–1279.

Edelhoich, H & Lippoldt, R.E. (1969). Structural studies on polypeptide hormones. Journal of Biological Chemistry, 244, 3876–3883.

Ekins, R.P. (1960). The estimation of thyroxine in human plasma by an electrophoretic technique. Clinica Chimica Acta, 5, 453–459.

Ekins, R.P. (1974). Basic principles and theory. British Medical Bulletin, 30, 3–11.

Ekins, R.P. (1981). Towards immunoassays of greater sensitivity, specificity and speed an overview. In: Monoclonal Antibodies and Developments in Immunoassay, ed. Albertini, A. & Ekins, R., pp 3–21. Amsterdam: Elsevier/North Holland.

Ekins, R.P. & Edwards, P.R. (1983). The precision profile : its use in assay design, assessment and quality control. In: Immunoassays for Clinical Chemistry, ed. Hunter, W.M. & Corrie, J.E.T., pp 76–105. Edinburgh : Churchill Livingstone.

Ellouz, F., Adam, A., Ciorbaru, R. & Lederer, E. (1974). Minimal structural requirements for adjuvant activity of bacterial peptidoglycan derivatives. Biochemical and Biophysical Research Communications, 59, 1317–1325.

Fasman, G.D., Chou, P.Y. & Adler, A.J. (1976). Prediction of the conformation of the hostones. Biophysical Journal, 16, 1201–1238.

Fenton, S., Somers S. & Heath, D.A.(1978). Preliminary studies with the sensitive cytochemical assay for parathyroid hormone. Clinical Endocrinology, 9, 381–384.

Fischer, J.A., Oldham, S.B., Sizemore, G.W. & Arnaud, C.D. (1971). Calcitonin stimulation of parathyroid hormone *in vitro*. Hormone and Metabolic Research, 3, 223–224.

Fiskin, A.M., Cohn, D.V. & Peterson, G.S. (1977). A model for the structure of bovine parathormone derived by dark field electron microscopy. Journal of Biological Chemistry, 252, 8261–8268.

Fluckiger, J.P., Waeber, B., Matsueda, G., Delaloye, B., Nussberger, J. & Brunner, H.R. (1986). Effect of atriopeptin III on hematocrit and volemia of nephrectomized rats. American Journal of Physiology, 251, H880–883.

Flynn, T.G., de Bold, M.L. & de Bold, A.J. (1983). The amino acid sequence of an atrial peptide with potent diuretic and natriuretic properties. Biochemical and Biophysical Research Communications, 117, 859–865

Fraker, P.J. & Speck J.C. (1978). Protein and cell membrane iodinations with a sparingly soluble chloroglycoluril. Biochemical and Biophysical Research Communications, 80, 849–857.

Frolich, M., Walma, S.T., Paulson, C. & Papapoulos, S.E.(1990). Immunoradiometric assay for intact human parathyroid hormone: characteristics, clinical application and comparison with a radioimmunoassay. Annals of Clinical Biochemistry, 27, 69–72.

Galfre, G., Howe, S.C., Milstein, C., Butcher, G.W. & Howard, J.C. (1977). Antibodies to major histocompatibility antigens produced by hybrid cell lines. Nature, 266, 550–552.

Galfre, G. & Milstein, C. (1981). Preparation of monoclonal antibodies: strategies and procedures. Methods in Enzymology, 73, 3–46.

Garcia, R., Thibault, G., Gutkowska, J., Cantin, M. & Genest, J. (1985). Changes of regional blood flow induced by atrial natriuretic factor (ANF) in conscious rats. Life Sciences , 36, 1685–1692.

Garcia, R., Cantin, M., Cusson, J.R. *et al* (1986). Some physiopathological aspects of atrial natriuretic factor. Journal of Hypertension, 4 supp.2, S125–S129.

Gavin, J.R. , Trivedi, B. & Daughaday, W.H. (1982). Homologous IM-9 lymphocyte radioreceptor and receptor modulation assays for human serum growth hormone. Journal of Clinical Endocrinology & Metabolism, 55 , 133–139.

Gefter, M.L., Margulies, D.H. & Scharff, M.D. (1977). A simple method for polyethylene glycol-promoted hybridization of mouse myeloma cells. Somatic Cell Genetics, 3, 231–236.

Gerbes, A.L, Arendt, R.M. Ritter, D., Jüngst, D. Zähringer, J. & Paumgartner, G. (1985). Plasma atrial natriuretic factor in patients with cirrhosis. New England Journal of Medicine, 313, 1609–1610.

Gil-Ad, I. , Topper, E. & Laron, Z. (1979) . Oral clonidine as a growth hormone stimulation test. Lancet , 2 , 278–280.

Goding, J.W. (1980). Antibody production by hybridomas. Journal of Immunological Methods, 39, 285–308.

Goltzman, D., Henderson, B. & Loveridge, N. (1980). Cytochemical bioassay of parathyroid hormone. Characteristics of the assay and analysis of circulating forms. Journal of Clinical Investigation, 65, 1309–1317.

Goodman, J.W. (1983). The complexity of structures involved in T-cell activation. Annual Review of Immunology, 1, 465–498.

Greenberg, B.D., Bencen, G.H., Seilhamer, J.J. Lewicki, J.A. & Fiddes, J.C. (1984). Nucleotide sequence of the gene encoding human atrial natriuretic factor precursor. Nature, 312, 656–658.

Greenspan, F.S. , Li, C.H. , Simpson, M.E. & Evans, H.M. (1949). Bioassay of hypophyseal growth hormone: the tibia test. Endocrinology , 45 , 455–463.

Guillemin, R. , Brazeau, P. , Böhlen, P. *et al* (1982). Growth hormone–releasing factor from a human pancreatic tumour that caused acromegaly. Science, 218, 585–587.

Gutkowska, J., Bourassa, M., Roy, D. *et al* (1985). Immunoreactive atrial natriuretic factor (IR–ANF) in human plasma. Biochemical and Biophysical Research Communications, 128, 1350–1357.

Haaijman, J.J., Deen, C., Kroese, C.J.M., Zijlstra, J.J., Coolen, J. & Radl, J. (1984). A jungle full of pitfalls. Immunology Today, 5, 56–58.

Hales, C.N. & Woodhead, J.S. (1980). Labelled antibodies and their use in the immunoradiometric assay. Methods in Enzymology, **70**, 334–355.

Hamet, P., Tremblay, J., Pang, S.C. *et al* (1984). Effects of native and synthetic atrial natriuretic factor on cyclic GMP. Biochemical and Biophysical Research Communications, **123**, 515–527.

Hartter, E., Woloszczuk, W. & Stummvoll, H-K. (1986). Radioimmunoassay of atrial natriuretic peptides in human plasma. Clinical Chemistry, **32**, 441–445.

Hashida, S., Ishikawa, E., Nakao, K., Mukoyama, M. & Imura, H. (1988). Specific and sensitive two-site enzyme immunoassay for α -, β - and γ -human atrial natriuretic polypeptides. 8th International Congress of Endocrinology, Abstract 21-18-079, 585.

Hawker, C.D., Clark, S.W., Martin, K.J., Slatopolsky, E. & DiBella F.P. (1983). Radioimmunoassay of parathyroid hormone: clinical utility and interpretation. In: Endocrine Surgery Update, ed. Thompson, W.A., Vinik, A.I., pp 321–40. New York : Grine and Stratton..

Hawker, C.D., Liebel, M.A., Clark, S.W., Martin, K.J. & Slatopolsky, E. (1984). Parathyroid hormone measurement: clinical utility of a radioimmunoassay for the C-terminal and middle region of PTH. Clinical Conformations, **5**, 1–7.

Hengartner, H., Luzzati, A.L. & Schreier, M. (1978). Fusion of *in vitro* immunised lymphoid cells with X63Ag8. Current Topics in Microbiology and Immunology, **81**, 92–99.

Hirata, Y., Tomita, M., Takada, S. & Yoshimi, H. (1985). Vascular receptor binding activities and cyclic GMP responses by synthetic human and rat ANP and receptor down regulation by ANP. Biochemical and Biophysical Research Communications, **128**, 538–546.

Hoogenraad, N., Helman, T. & Hoogenraad, J. (1983). The effect of pre-injection of mice with pristane on ascites tumour formation and monoclonal antibody production. Journal of Immunological Methods, **61**, 317–320.

Hunter, W.M., Bennie, J.G, Budd, P.S. *et al* (1983). Immunoradiometric assays using monoclonal antibodies. In: Immunoassays for Clinical Chemistry, ed. Hunter, W.M. & Corrie, J.E.T., pp 531–544. Edinburgh : Churchill Livingstone.

Hunter, W.M & Greenwood, F.C. (1962). Preparation of iodine-¹³¹ labelled human growth hormone of high specific activity. Nature, 194, 495–496.

Hunter, W.M. & Budd, P.S. (1981). Immunoradiometric versus radioimmunoassay : a comparison using alpha-fetoprotein as the model analyte. Journal of Immunological Methods , 45 , 255–273.

Hunter, W.M. & Greenwood, F.C. (1964). A radio-immunoelectrophoretic assay for human growth hormone. Biochemical Journal , 91 ,43–56.

Hurn, B.A.L. & Landon, J. (1971). Antisera for radioimmunoassay. In: Radioimmunoassay Methods, ed. Kirkham, K.E. & Hunter, W.M., pp 121–142. Edinburgh : Churchill Livinstone.

Iinuma, K., Ikeda, I., Ogihara, H. *et al* (1987). Radioimmunoassay of atrial natriuretic polypeptide in heat-treated human plasma. Clinical Chemistry, 33, 674–676.

Jandinski, J., Cantor, H., Tadakuma, T., Peavy, D.L. & Pierce, C.W. (1976). Separation of helper T cells from suppressor T cells expressing different Ly components. I Polyclonal activation : suppressor and helper activities are inherent properties of distinct T cell subclasses. Journal of Experimental Medicine, 143, 1382–1390.

Januszewicz, P., Thibault, G., Garcia, R., Gutkowska, J., Genest, J. & Cantin, M. (1986). Effect of synthetic atrial natriuretic factor on arginine vasopressin release by the rat hypothalamo-neurohypophyseal complex in organ culture. Biochemical and Biophysical Research Communications ,134, 652–658.

John, A., Stasch, J.-P., Neuser, D., Hirth, C. & Morich, F.J. (1986). The use of a monoclonal antibody to measure plasma atriopeptins in rat. Life Sciences, 38, 1991–1997.

Kangawa, K., & Matsuo, H. (1984). Purification and complete amino acid sequence of α -human atrial natriuretic peptide (α -hANP). Biochemical and Biophysical Research Communications, 118, 131-139.

Karonen, S.L. Morsky, P., Siren, M. & Seuderling, U. (1975). An enzymatic solid-phase method for trace iodination of proteins and peptides with 125 iodine. Analytical Biochemistry, 67, 1-10.

Katoh, Y., Kurosawa, T., Takeda, S. *et al* (1986). Atrial natriuretic peptide levels in treated congestive heart failure. Lancet, 1, 851.

Katz, D.H., Graves, M., Dorf, M.E., Dimuzio, H. & Benacerraf, B. (1975). Cell interactions between histoincompatible T and B lymphocytes. VII Cooperative responses between lymphocytes are controlled by genes in the I region of the H-2 complex. Journal of Experimental Medicine, 141, 263-268.

Kearney, J.F, Radbruch, A., Liesegang, B. & Rajewsky, K. (1979). A new mouse myeloma cell line that has lost immunoglobulin expression but permits the construction of antibody-secreting hybrid cell lines. Journal of Immunology, 123, 1548-1550.

Kilmartin, J.V., Wright, B. & Milstein, C. (1982). Rat monoclonal antitubulin antibodies derived by using a nonsecreting rat cell line. Journal of Cell Biology, 93, 576-582.

Kisch, B. (1956). Electron microscopy of the atrium of the heart. Experimental Medicine and Surgery, 14, 99-112.

Knutton, S. & Pasternak, P.A. (1979). The mechanism of cell-cell fusion. Trends in Biochemical Sciences, 4, 220-223.

Kohler, G. & Milstein, C. (1975). Continuous cultures of fused cells secreting antibody of predefined specificity. Nature, 256, 495-497.

Kohler, G., Howe, S.C. & Milstein, C. (1976). Fusion between immunoglobulin-secreting and non secreting myeloma cell lines. European Journal of Immunology, 6, 292–295.

Kronenberg, H.M. *et al* (1986). Structure and expression of the human parathyroid hormone gene. Recent Progress in Hormone Research, 42, 641–663.

Kukreja, S.C. *et al* (1976). Role of calcium and beta–adrenergic systems in control of parathyroid hormone secretion. Proceedings of the Society for Experimental Biology and Medicine , 151, 326–328.

Kurtz, A., Della Bruna, R., Pfeilschifter, J. & Bauer, C. (1986). Atrial natriuretic peptide inhibits renin release from juxtaglomerular cells by a cGMP–mediated process. Proceedings of the National Academy of Science USA, 83, 4769–4773.

Lang, R.E., Thölken, H., Ganten, D., Luft, F.C., Ruskoaho, H. & Unger, Th. (1985). Atrial natriuratic factor – a circulating hormone stimulated by volume loading. Nature, 314, 264–266.

Lang, R.E., Unger, T., Ganten, D., Weil, J., Bidlingmaier, F. & Dohlemann, D. (1985^b). α -Atrial natriuretic peptide concentrations in plasma of children with congenital heart and pulmonary diseases. British Medical Journal, 291, 1241.

Lanzavecchia, A. (1986). Antigen presentation by B lymphocytes : a critical step in T–B collaboration. Current Topics in Microbiology and Immunology. 130, 65–78.

Léan De, A., Gutkowska, J., McNicoll, N., Schiller, P.W., Cantin, M. & Genest, J. (1984^a). Characterisation of specific receptors for atrial natriuretic factor in bovine adrenal zona glomerulosa. Life Sciences, 35, 2311–2318.

Léan De, A., Racz, K., Gutkowska, J., Nguyen, T.T., Cantin, M. & Genest, J. (1984^b). Specific receptor–mediated inhibition by synthetic atrial natriuretic factor of hormone–stimulated steroidogenesis in cultured bovine adrenal cells. Endocrinology, 115, 1636–1638.

Léan De, A., Vinay, P. & Cantin, M. (1985). Distribution of atrial natriuretic factor receptors in dog kidney fractions. FEBS Lett, 193, 239–241.

Ledsome, J.R., Wilson, N., Courneya, C.A. & Rankin, A.J. (1985). Release of atrial natriuretic peptide by atrial distension. Canadian Journal of Physiology and Pharmacology, 63, 739–742.

Lerner, R.A. (1982). Tapping the immunological repertoire to produce antibodies of predetermined specificity. Nature, 299, 592– 596.

Lerner, R.A. (1984). Antibodies of predetermined specificity in biology and medicine. Advances in Immunology, 36, 1–44.

Lernhardt, W., Anderson, J., Coutinho, A. & Melchers, F. (1978). Cloning of murine transformed cell lines in suspension culture with efficiencies near 100%. Experimental Cell Research, 111, 309–316 .

Lesniak, M.A. , Gorden, P. , Roth, J. & Gavin, J.R. (1974). Binding of ¹²⁵I–human growth hormone to specific receptors in human cultured lymphocytes : characterisation of the interaction and a sensitive radioreceptor assay. Journal of Biological Chemistry ,249 ,1661–1667.

Lesniak, M.A. , Roth, J. , Gorden, P. & Gavin, J.R. (1973). Human growth hormone radioreceptor assay using cultured human lymphocytes. Nature New Biology, 241, 20–22.

Levy, R., Dilley, J. & Lampson, L.A. (1978). Human normal leukemia cell surface antigens. Mouse monoclonal antibodies as probes. Current Topics in Microbiology and Immunology, 81, 164–169.

Lewicki, J.A., Greenberg, B., Yamanaka, M. *et al* (1986). Cloning, sequence analysis and processing of the rat and human atrial natriuretic factor precursors. Federation Proceedings, 45 , 2086–2090.

Lewis, U.J., Bonewald, L.F. & Lewis, L.J. (1980). The 20000-dalton variant of human growth hormone : location of the amino acid deletions. Biochemical and Biophysical Research Communications , 92 , 511–516.

Lewis, H.M., Ratcliffe, W.A., Stott, R.A.W., Wilkins, M.R. & Baylis, P.H. (1989). Development and validation of a two site immunoradiometric assay for human atrial natriuretic factor (ANF) in unextracted plasma. Journal of Endocrinology, 121 supp., 271.

Lindall, A.W., Elting, J., Ells, J. & Roos, B.A. (1983). Estimation of biologically active intact parathyroid hormone in normal and hyperparathyroid sera by sequential N-terminal immunoextraction and midregion radioimmunoassay. Journal of Clinical Endocrinology and Metabolism, 57, 1007–1014.

Littlefield, J.W. (1964). Selection of hybrids from matings of fibroblasts in vitro and their presumed recombinants. Science, 145, 709–710.

Lo, M.M.S et al (1984). Monoclonal antibody production by receptor-mediated electrically induced cell fusion. Nature, 310, 792–794.

Logue, F.C., Perry, B., Chapman, R.S. & Biggart, E.M. (1986). Monoclonal antibodies to human parathyroid hormone (1–34). Journal of Endocrinology, 111 supp., 62.

Logue, F.C., Perry, B., Chapman, R.S., James, K. & Beastall, G.H. (1988). The development of a two-site immunometric assay (IRMA) for intact 1–84 human parathyroid hormone using monoclonal antibodies. Journal of Endocrinology, 117 supp., 67.

Logue, F.C., Fraser, W.D., Gallacher, S. *et al* (1989^a). Bisphosphonate effects on calcium, PTH(1–84) and nephrogenous cAMP (NcAMP) in patients with hypercalcaemia of malignancy (HCM) and Paget's disease. Proceedings of the National Meeting of the Association of Clinical Biochemists, Focus '89. Abstract .

Logue, F.C., Fraser, W.D., O'Reilly, D. St.J. & Beastall, G.H.(1989^b). The circadian rhythm of intact parathyroid hormone (1–84) and nephrogenous cyclic adenosine monophosphate in normal men. Journal of Endocrinology, 121, R1–R3.

Logue, F.C., Fraser, W.D., Gallacher, S.J. *et al* (1990). The loss of circadian rhythm for intact parathyroid hormone and nephrogenous cyclic AMP in patients with primary hyperparathyroidism. Journal of Clinical Endocrinology, 32, 475–483.

Lowry, O.H., Rosenbrough, N.J., Farr, A.L. & Randall, R.J. (1951). Protein measurement with the Folin Phenol reagent. Journal of Biological Chemistry, 193, 265–275.

Maack, T., Marion, D.N., Camargo, M.J.F. *et al* (1984). Effect of auriculin (atrial natriuretic factor) on blood pressure, renal function, and the renin–aldosterone system in dogs. American Journal of Medicine, 77, 1069–1075.

MacGregor, R.R., Hamilton, J.W. & Cohn, D.V. (1975). The bypass of tissue hormone stores during the secretion of newly synthesised parathyroid hormone. Endocrinology, 97, 178–188.

Malan, P.G., Cox, M.G., Long, E.M.R. & Ekins, R.P. (1978). Curve fitting to radioimmunoassay standard curves spline and multiple binding site models. Annals of Clinical Biochemistry, 15, 123–135.

Marie, J.P., Guillemot, H. & Hatt, P.Y. (1976). Le degré de granulation des cardiocytes auriculaires. Etude planimétrique au coeurs de différents apports d'eau et de sodium chez le rat. Pathologie–Biologie (Paris), 24, 549–554.

Martin, K.J., Hruska, K. Freitag, J., Bellorin–Font, E., Klahr, S. & Slatopolsky, E. (1980). Clinical utility of radioimmunoassays for parathyroid hormone. Mineral and Electrolyte Metabolism, 3, 283–290.

Marx, S.J., Sharp, M.E., Krudy, A., Rosenblatt, M. & Mallette, L.E. (1981). Radioimmunoassay for the middle region of human parathyroid hormone : studies with a radioiodinated synthetic peptide. Journal of Clinical Endocrinology and Metabolism, 53, 76–84.

Mayer, G.P. & Hurst, J.G. (1978). Sigmoidal relationship between parathyroid hormone secretion rate and plasma calcium concentration in calves. Endocrinology, 102, 1036–1042.

McConnell, I., Munro, A. & Waldmann, H. (1981). The Immune System: A Course on the Molecular and Cellular Basis of Immunity, 2nd edn. Oxford : Blackwell.

McConway, M.G. *et al* (1989). How sensitive are immunometric assays for thyrotrophin. Clinical Chemistry , 35 , 289–291.

Michener, M.L., Gierse, J.K., Seetharam, R. *et al* (1986). Proteolytic processing of atriopeptin prohormone. Molecular Pharmacology, 30, 552–557.

Miles, L.E.M. & Hales, C.N. (1968^a). Labelled antibodies and immunological assay systems. Nature, 219, 186–189.

Miles, L.E.M. & Hales, C.N. (1968^b). Immunoradiometric assays of human growth hormone. Lancet , 2 , 492–493.

Miller, W.L. & Eberhardt, N.L. (1983). Structure and evolution of the growth hormone gene family. Endocrine Reviews , 4 , 97–130.

Milne, R., Gutkowska, J., Thibault, G., Schiller, P., Charbonneau, C., Genest, J. & Cantin, M. (1987). A murine monoclonal antibody against rat atrial natriuretic factor (ANF) which cross-reacts with mouse ANF. Molecular Immunology, 24, 127–132.

Misano, K.S., Fukumi, H., Grammer, R.T. & Inagami, T. (1984). Rat atrial natriuretic factor : complete amino acid sequence and disulfide linkage essential for biological activity. Biochemical and Biophysical Research Communications, 119, 524–529.

Mitchell, G.F. & Miller, J.F.A.P. (1968). Cell to cell interaction in the immune response. The source of hemolysin-forming cells in irradiated mice given bone marrow and thymus or thoracic duct lymphocytes. Journal of Experimental Medicine, 128, 821–837.

Miyata, A., Toshimori, T., Hashiguchi, T., Kangawa, K. & Matsuo, H. (1987). Molecular forms of atrial natriuretic polypeptides circulating in human plasma. Biochemical and Biophysical Research Communications, 142, 461–467.

Morrissey, J.J. & Cohn, D.V. (1979). Secretion and degradation of parathormone as a function of intracellular maturation of hormone pools: modulation by calcium and dibutyryl cyclic AMP. Journal of Cell Biology, 83, 521–528.

Mukoyama, M., Nakao, K., Yamada, T. *et al* (1988). Monoclonal antibodies against atrial natriuretic polypeptide precursor. 8th International Congress of Endocrinology, Abstract 21–18–078, 584.

Mundy, G.R. (1989). Homeostasis : Hypercalcemia and Hypocalcemia. London : Martin Dunitz.

Murphy, K.H.M., McLaughlin, L.L., Michener, M.L. & Needleman, P. (1985). Autoradiographic localization of atriopeptin III receptors in rat kidney. European Journal of Pharmacology, 111, 291–292.

Nakao, K., Sugawara, A., Morii, N. *et al* (1984). Radioimmunoassay for α -human and rat atrial natriuretic polypeptide. Biochemical and Biophysical Research Communications, 124, 815–821.

Nakaoka, H., Imataka, K., Amano, M., Fujii, J., Ishibashi, M. & Yamaji, T. (1985). Plasma levels of atrial natriuretic factor in patients with congestive heart failure. New England Journal of Medicine, 313, 892–893.

Naomi, S., Umeda, T., Sato, T., Harada, N. Tominaga, A. & Takatsu, K. (1987). Production and characterisation of monoclonal antibodies against amino-terminus of human α -atrial natriuretic polypeptide. Hybridoma, 6, 433–440.

Naomi, S., Umeda, T., Iwaoka, T. *et al* (1988). Radioimmunoassay of α human atrial natriuretic peptide using monoclonal antibodies with distinct specificities. 8th International Congress of Endocrinology, Abstract 21-18-077, 584.

Napier, M.A., Vandlen, R.L., Albers-Schönberg, G. *et al* (1984). Specific membrane receptors for atrial natriuretic factor in renal and vascular tissues. Proceedings of the National Academy of Sciences of the U.S.A., 81, 5946-5950.

Naruse, M., Naruse, K., Obana, K. *et al* (1986). Immunoreactive alpha-human atrial natriuretic polypeptide in human plasma. Peptides, 7, 141-145.

Naylor, S.L., Sakaguchi, A.Y., Szoka, P., Hendy, G.H., Kronenberg, H. & Rich, A. (1983). Human parathyroid hormone gene (PTH) is on short arm of chromosome 11. Somatic Cell Genetics, 9, 609-616.

Needleman, P., Adams, S.P., Cole, B.R. *et al* (1985). Atriopeptins as cardiac hormones. Hypertension, 7, 469-482.

Nicklas, J.M., DiCarlo, L.A., Koller, P.T. *et al* (1986). Plasma levels of immunoreactive atrial natriuretic factor increase during supraventricular tachycardia. American Heart Journal, 112, 923-928.

Niepel, B., Rodeke, H., Atkinson, M.J., Jueppner, H. & Hersh R.D. (1983). A homologous biological probe for parathyroid hormone in human serum. Journal of Immunoassay, 4, 21-47.

Nishiuchi, T., Saito, H., Yamasaki, Y. & Saito, S. (1986). Radioimmunoassay for atrial natriuretic peptide : method and results in normal subjects and patients with various diseases. Clinica Chimica Acta, 159, 45-57.

Nissenson, R.A., Abbott, S.R., Teitelbaum, A.P., Clark, O.H. & Arnaud, C.D. (1981). Endogenous biologically active parathyroid hormone : measurement by a guanyl nucleotide-amplified renal adenylate cyclase assay. Journal of Clinical Endocrinology and Metabolism, 52, 840-846.

Noeman, S.A., Misrs, D.N., Yankes, R.J., Kunz, H.W. & Gill, J.J. (1982). Growth of mouse–rat hybridomas in nude mice and rats. Journal of Immunological Methods, 55, 319–326.

Nonoguchi, H., Knepper, M.A. & Manganiello, V.C. (1987). Effects of atrial natriuretic factor on cyclic guanosine monophosphate and cyclic adenosine monophosphate accumulation in microdissected nephron segments from rats. Journal of Clinical Investigation , 79, 500–507.

Nussbaum, S.R., Lin, C.S., Potts, J.T., Rosenthal, A.S. & Rosenblatt, M.(1985). Development of monoclonal antibodies against parathyroid hormone : genetic control of the immune response to human PTH. Methods in Enzymology, 109, 625–638.

Nussbaum, S.R. *et al* (1987). Highly sensitive two–site immunoradiometric assay of parathyrin and its clinical utility in evaluating patients with hypercalcaemia. Clinical Chemistry, 33, 1364–1367.

Oi, V.T., Jones, P.P., Goding, J.W., Herzenberg, L.A. & Herzenberg, L.A. (1978). Properties of monoclonal antibodies to mouse Ig allotypes, H-2, and Ia antigens. Current Topics in Microbiology and Immunology, 81, 115–129.

Oi, V.T. & Herzenberg, L.A. (1980). Immunoglobulin–producing hybrid cell lines. In: Selected Methods in Cellular Immunology , ed. Mishell, B.B. & Shiigi, S.M., pp 351–372. San Francisco : Freeman.

Oikawa, S., Imai, M., Ueno, A. *et al* (1984). Cloning and sequence analysis of cDNA encoding a precursor for human atrial natriuretic polypeptide. Nature, 309, 724–726.

Orth, D.N. (1979). Adrenocorticotrophic hormone. In: Methods of Hormone Radioimmunoassay, ed. Jaffe, B.M. & Behrman, H.R., 2nd edn., Ch 12, pp 245–284. New York : Academic Press.

Otsuki, Y., Okamoto, E., Iwata, I. *et al* (1987). Changes in concentration of human atrial natriuretic peptide in normal pregnancy and toxemia. Journal of Endocrinology, 114, 325–328.

Papapoulos, S.E., Manning, R.M., Hendy, G.N., Lewin, I.G. & O'Riordan, J.L.H. (1980). Studies of circulating parathyroid hormone in man using a homologous amino-terminal specific immunoradiometric assay . Clinical Endocrinology, 13, 57–67.

Parker, D.C., Rossman, L.G., Kripke, D.F., Gibson, W. & Wilson, K. (1979). Rhythmicities in human growth hormone concentrations in plasma. In: Endocrine Rhythms , ed. Krieger, D.T., pp 143–173. New York : Raven Press.

Patt, H.M. & Luckhardt, A.B. (1942). Relationship of a low blood calcium to parathyroid secretion. Endocrinology ,31, 384–392.

Payne, N.N., O'Shea, A., Slater, J.D.H.S., Ekins, R.P. & Thakur, A.N. (1987). Production and characterisation of monoclonal antibodies to atrial natriuretic peptides. Journal of Endocrinology, 112 supp., 252.

Perry, B., Chapman, R.S., Logue, F.C. & Beastall, G.H. (1987). Observations on the radioiodination of human α -atrial natriuretic peptide. Journal of Endocrinology, 112 supp., 251.

Perry, B., Chapman, R.S., McConway, M.G., Griffin, D. & Beastall, G.H. (1991). Specificity of two-site immunometric assays. Annals of Clinical Biochemistry, 28, 83–86.

Philips, J.A. (1987). Regulation of and defects in expression of growth hormone genes. In: Growth Hormone – Basic and Clinical Aspects , ed. Isaksson, O., Binder, C., Hall, K. & Hökfelt, B., pp 11–27. Amsterdam : Excerpta Medica.

Poole, C.J.M., Carter, D.A. Vallejo, M. & Lightman, S.L. (1987). Atrial natriuretic factor inhibits the stimulated in-vivo and in-vitro release of vasopressin and oxytocin in the rat. Journal of Endocrinology, 112, 97–102.

Pritchard, J.A., Cunningham, F.G. & Pritchard, S.A. (1984). The Parkland Memorial Hospital protocol for treatment of eclampsia : evaluation of 245 cases. American Journal of Obstetrics and Gynecology, 148, 951–963.

Prowse, C., George, E., Micklem, L.R., Hornsey, V., Brown, J. & James, K. (1989). Human atrial natriuretic factor (ANF) : characterisation of a monoclonal antibody panel and its use in radioimmunoassay. Journal of Immunological Methods, 118, 91–100.

Quiron, R., Dalpé, M., De Lean, A., Gutkowska, J., Cantin, M. & Genest, J. (1984). Atrial natriuretic factor binding sites in brain and related structures. Peptides, 5, 1167–1172.

Ratcliffe, J.G. (1983). Requirements for separation methods in immunoassay. In: Immunoassays for Clinical Chemistry, ed. Hunter, W.M. & Corrie, J.E.T., pp 531–544. Edinburgh : Churchill Livingstone.

Ratcliffe, W.A., Heath, D.A. & Pugh, J. (1989). Evaluation of N-tact parathyroid hormone IRMA (INCSTAR). Proceedings of the National Meeting of the Association of Clinical Biochemists, Focus '89. Abstract 154.

Reading, C.L. (1982). Theory and methods for immunization in culture and monoclonal antibody production. Journal of Immunological Methods, 53, 261–291.

Reay, P. (1982). Use of N-bromosuccinimide for the iodination of proteins for radioimmunoassay. Annals of Clinical Biochemistry, 19, 129–133.

Reichlin, S. (1985). In: Williams Textbook of Endocrinology, ed. Wilson, J.D. & Foster, D.W., 7th edn. , Ch. 17, pp 492–567. Philadelphia : Saunders.

Reiss, E. & Canterbury, J.M. (1968). A radioimmunoassay for parathyroid hormone in man. Proceedings of the Society for Experimental Biology and Medicine, 128, 501–504.

Ringertz, N.R. & Savage, R.E. (1976). Cell Hybrids. New York: Academic Press.

Rivier, J., Spiess, J., Thorner, M. & Vale, W. (1982). Characterisation of a growth hormone-releasing factor from a human pancreatic islet tumour. Nature, 300, 276–278.

Roos, B.A., Lindall, A.W., Aron, D.C. *et al* (1981). Detection and characterisation of small midregion parathyroid hormone fragment(s) in normal and hyperparathyroid glands and sera by immunoextraction and region specific radioimmunoassays. Journal of Clinical Endocrinology and Metabolism, 53, 709–721.

Rosmalen, F.M.A., Tan, A.C.I.T.L., Tan, H.S. & Benraad, T.J. (1987). A sensitive radioimmunoassay of atrial natriuretic peptide in human plasma, using a tracer with an immobilized glycouril agent. Clinica Chimica Acta, 165, 331–340.

Sagnella, G.A., Markandu, N.D., Shore, A.C. & MacGregor, G.A. (1986). Raised circulating levels of atrial natriuretic peptides in essential hypertension. Lancet, 1, 179–181.

Sagnella, G.A., Buckley, M.G., Markandu, N.D. & MacGregor, G.A. (1987). Atrial natriuretic peptide in human plasma : comparison of radioreceptor vs radioimmunoassay. In: The American Society of Hypertension, Second World Congress on Biologically Active Atrial Peptides, pp 208.

Salmon, W.D. & Daughaday, W.H. (1957). A hormonally controlled serum factor which stimulates sulphate incorporation by cartilage in vitro. Journal of Laboratory and Clinical Medicine , 49 ,825–836.

Saper, C.B., Standaert, D.G., Currie, M.G., Schwartz, D., Geller, D.M. & Needleman, P. (1985). Atriopeptin-immunoreactive neurons in the brain : presence in cardiovascular regulatory areas. Science , 227, 1047–1049.

Schacterle, G.R. & Pollack, R.L. (1973). A simplified method for the quantitative assay of small amounts of protein in biological material. Analytical Biochemistry, 51, 654–655.

Schiffrin, E.L., Gutkowska, J., Kuchel, O., Cantin, M. & Genest, J. (1985). Plasma concentration of atrial natriuretic factor in patients with paroxysmal atrial tachycardia. New England Journal of Medicine, 312, 1196–1197.

Schlom, J., Wunderlich, D. & Teramoto, Y. A. (1980). Generation of human monoclonal antibodies reactive with human mammary carcinoma cells. Proceedings of the National Academy of Science USA, 77, 6841–6845.

Schmitz, H.E., Atassi, H. & Atassi, M.Z. (1983). Production of monoclonal antibodies with preselected submolecular binding specificities to protein antigenic sites: antibodies to sperm whale myoglobin sites. Molecular Immunology, 20, 719–726.

Schwartz, R.H. (1986). Immune response (I_r) genes of the murine major histocompatibility complex. Advances in Immunology, 38, 31–201.

Scottish Inter-Laboratory Services Directory (1987). Scottish Home and Health Department : Edinburgh.

Seidman, C.E., Bloch, K.D., Klein, K.A., Smith, J.A. & Seidman, J.G. (1984). Nucleotide sequences of human and mouse atrial natriuretic factor genes. Science, 226, 1206–1209.

Shenker, Y., Sider, R.S., Ostafin, E.A. & Grekin, R.J. (1985). Plasma levels of immunoreactive atrial natriuretic factor in healthy subjects and in patients with edema. Journal of Clinical Investigation , 76, 1684–1687.

Sherwood, L.M., Mayer, G.P., Ramberg, C.F., Kronfield, D.S., Aurbach, G.D. & Potts, J.T. (1968). Regulation of parathyroid hormone secretion : proportional control by calcium, lack of effect of phosphate. Endocrinology, 83, 1043–1051.

Sherwood, L.M. & Abe, M. (1972). Adrenergic receptors and the release of parathyroid hormone. Journal of Clinical Investigation , 51, 88a.

Siddle, K. (1985). Monoclonal antibodies in clinical biochemistry. In: Recent Advances in Clinical Biochemistry, ed. Price, C.P. & Alberti, K.G.M.M., Vol 3, Ch 3, pp 63–102. Edinburgh : Churchill Livingstone.

Silverman, R. & Yalow, R.S. (1973). Heterogeneity of parathyroid hormone. Clinical and physiological implications. Journal of Clinical Investigation, 52, 1958–1971.

Soini, E. & Hemmila, I. (1979). Fluorimmunoassay : present status and key problems. Clinical Chemistry, 25, 353–361.

Spitz, M., Spitz, L., Thorpe, R. & Eugui, E. (1984). Intrasplenic primary immunization for the production of monoclonal antibodies. Journal of Immunological Methods, 70, 39–43.

Staros, J.V. *et al* (1986). Enhancement by N-hydroxysulfosuccinimide of water-soluble carbodiimide-mediated coupling reactions. Analytical Biochemistry, 156, 220–222.

Stasch, J.P., Neuser, D., John, A., Hein, D., Heuck, K. & Morich, F.-J. (1987). The use of a monoclonal antibody for the determination of atrial natriuretic peptides in human plasma. Klinische Wochen., 65, 533–537.

Steardo, L. & Nathanson, J.A. (1987). Brain barrier tissues : end organs for atriopeptins. Science, 235, 470–473.

Steinbuch, M. & Audran, R. (1969). The isolation of IgG from mammalian sera with the aid of caprylic acid. Archives of Biochemistry and Biophysics, 134, 279–284.

Stewart, P.M., Smith, S., Seth, J., Stewart, S.E., Cole, D. & Edwards, C.R.W. (1989). Normal growth hormone response to the 75g oral glucose tolerance test measured by immunoradiometric assay. Annals of Clinical Biochemistry , 26 , 205–206.

Sugawara, A., Nakao, K., Sakamoto, M. *et al* (1985). Plasma concentration of atrial natriuretic polypeptide in essential hypertension. Lancet, 2, 1426–1427.

Sukegawa, I., Hizuka, N., Takano, K. *et al* (1988). Urinary growth hormone (GH) measurements are useful for evaluating endogenous GH secretion. Journal of Clinical Endocrinology and Metabolism , 66 , 1119–1123.

Tanaka, I., Misono, K.S. & Inagami, T. (1984). Atrial natriuretic factor in rat hypothalamus, atria, and plasma : determination by specific radioimmunoassay. Biochemical and Biophysical Research Communications , 124, 663–668.

Tang, J., Song, D.L., Suen, M.Z. *et al* (1986). Alpha–human atrial natriuretic polypeptide (alpha–hANP) in normal volunteers and patients with heart failure or hypertension. Peptides, 7, 33–37.

Targovnik, J.H., Rodman, J.S. & Sherwood, L.M. (1971). Regulation of parathyroid hormone secretion in vitro : quantitative aspects of calcium and magnesium ion control. Endocrinology, 88, 1477–1482.

Tashjian, A.H., Ontjes, D.A & Munson, P.L. (1964). Alkylation and oxidation of methionone in bovine parathyroid hormone: effects on hormonal activity and antigenicity. Biochemistry, 3, 1175–1182.

Tattersall, J.E., Dawnay, A., McLean, C., Cattell, W.R. & Landon, J. (1989). Rapid measurement of atrial natriuretic peptide (ANP) in unextracted plasma using an immunoradiometric assay (IRMA). Journal of Endocrinology, 121 supp., 266.

Thorpe, G., Kricka, L.J. Mosely, S.B. & Whithead, T.P. (1985). Phenols as enhancers of the chemiluminescent horseradish peroxide–luminoi–hydrogen peroxide reaction : Applications in luminescence monitored enzyme immunoassays. Clinical Chemistry, 31, 1335–1341.

Tikkanen, I., Fyhrquist, F., Metsärinne, K. & Leidenius, R. (1985). Plasma atrial natriuretic peptide in cardiac disease and during infusion in healthy volunteers. Lancet, 1, 66–69.

Tremblay, J., Gerzer, R., Vinay, P., Pang, S.C., Beliveau, R. & Hamet, P. (1985). The increase of cGMP by atrial natriuretic factor correlates with the distribution of particulate guanylate cyclase. FEBS Lett, 181, 17–22.

Trippodo, N.C., Ghai, R.D., MacPhee, A.A. & Cole, F.E. (1984). Atrial natriuretic factor: atrial conversion of high to low molecular weight forms. Biochemical and Biophysical Research Communications, 119, 282–288.

Tunny, T.J. & Gordon, R.D. (1986^a). Plasma atrial natriuretic peptide in primary aldosteronism (before and after treatment) and in Bartter's and Gordon's syndromes. Lancet, 1, 272–273.

Tunny, T.J., Higgins, B.A. & Gordon, R.D. (1986^b). Plasma levels of atrial natriuretic peptide in man in primary aldosteronism, in Gordon's syndrome and in Bartter's syndrome. Clinical and Experimental Pharmacology and Physiology, 13, 341–345.

Unanue, E.R. (1972). The regulatory role of macrophages in antigenic stimulation. Advances in Immunology, 15, 95–165.

Unanue, E.R. Dorf, M.E., David, C.S. & Benacerraf, B. (1974). The presence of I-region-associated antigens on B-cells in molecules distinct from immunoglobulin and H-2K and H-2D. Proceedings of the National Academy of Science USA, 71, 5014–5016.

Underwood, L.E. & Judson J.V.W. (1985). In: Williams Textbook of Endocrinology, ed. Wilson, J.D. & Foster, D.W., 7th edn., Ch. 8, pp 155–205. Philadelphia : Saunders.

Vaitukaitus, J., Robbins, J.B., Nieschlag, E. & Ross, G.T. (1971). A method for producing specific antisera with small doses of immunogen. Journal of Clinical Endocrinology, 33, 998–991.

Valente, W. A., Vitti, P., Yavin, Z. *et al* (1982). Monoclonal antibodies to the thyrotrophin receptor : stimulating and blocking antibodies derived from lymphocytes of patients with Graves Disease. Proceedings of the National Academy of Science USA, 79, 6680–6684.

Valentine, R.C. & Green, N.M. (1967). Electron microscopy of an antibody–hapten complex. Journal of Molecular Biology, 27, 615–617.

Van den Berg, H., Driedonks, L., Grinsven, H.V. & Schuurs, A. (1982). The use of monoclonal antibodies against prolactin in a solid phase enzyme immunoassay. Protides of the Biological Fluids, 29, 847–850.

Van der Merwe, W., Rodger, R.S.C., Grant, A.C., Beastall, G.H., Logue, F., Briggs, J.D. & Junor, B.J.R. (1988). Hypocalcaemic dialysate in combination with high–dose oral calcitriol in the treatment of secondary hyperparathyroidism in chronic haemodialysis patients. Scottish Renal Association Bulletin.

Vienken, J. & Zimmermann, U. (1982). Electric field–induced fusion: Electro–hydraulic procedures for production of heterokaryon cell in high yield. FEBS Letters, 137, 11–13.

Wallis, M. (1985). In: The Biochemistry of the Polypeptide Hormones , ed. Wallis, M., Howell, S.L. & Taylor, K.W. , Ch 8, pp 223–255. Chichester : Wiley.

Wardner De, H.E., Mills, I.H., Clapham, W.F & Hayter, C.J. (1961). Studies on the efferent mechanism of the sodium diuresis which follows the administration of intravenous saline in the dog. Clinical Science, 21, 249–258.

Warren, H.S., Vogel, F.R. & Chedid, L.A. (1986). Current status of immunological adjuvants. Annual Review of Immunology, 4, 369–388.

Weeks, I., Kemp, H.A. & Woodhead, J.S. (1981). Two–site assay of human alpha–1–fetoprotein using ¹²⁵I–labelled monoclonal antibodies. Bioscience Reports, 1, 785–791.

Weeks, I, Sturgess, M., Siddle, K., Jones, M.K. & Woodhead, J.S. (1984). A high sensitivity immunochemiluminometric assay for human thyrotrophin. Clinical Endocrinology, 20, 489–495.

Weeks, I. & Woodhead, J.S. (1986). Measurement of human growth hormone (hGH) using a rapid immunochemiluminometric assay. Clinica Chimica Acta , 159 , 139–145.

White, J. & Helenius, A. (1980). pH dependent fusion between the Semliki Forest virus membrane and liposomes. Proceedings of the National Academy of Science USA, 77, 3273–3277.

Whitehead, T.P., Thorpe, G.H.G., Carter, T.J.N., Groucuti, C. & Kricka, L.J. (1983). Enhanced luminescence procedure for sensitive determination of peroxidase-labelled conjugates in immunoassay. Nature, 305, 158–159.

Wilkins, M.R., Wood, J.A., Adu, D., Lote, C.J., Kendall, M.J. & Michael, J. (1986). Change in plasma immunoreactive atrial natriuretic peptide during sequential ultrafiltration and haemodialysis. Clinical Science, 71, 157–160.

Williams, G.A., Hargis, G.K., Bowser, E.N., Henderson, W.J. & Martinez, N. (1973). Evidence for a role of adenosine 3',5'-monophosphate in parathyroid hormone release. Endocrinology, 92, 687–691.

Winqvist, R.J., Faison, E.P., Waldman, S.A., Schwartz, K., Murad, F. & Rapoport, R.M. (1984). Atrial natriuretic factor elicits an endothelium-independent relaxation and activates particulate guanylate cyclase in vascular smooth muscle. Proceedings of the National Academy of Science of the USA , 81, 7661–7664.

Woodhead, J.S., Addison, G.M. & Hales, C.N. (1974). The immunoradiometric assay and related techniques. British Medical Bulletin, 30, 44–49.

Wright, D.R., Goodman, A.D. & Tremble, K.D. (1974). Studies on "big" growth hormone from human plasma and human pituitary. Journal of Clinical Investigation, 54, 1064–1073.

Yalow, R.S. & Berson, S.A. (1960). Immunoassay of endogenous plasma insulin in man. Journal of Clinical Investigation, 39, 1157–1175.

Yamada, K., Tajima, K., Moriwaki, K. *et al* (1986). Atrial natriuretic peptide in Bartter's syndrome. Lancet, 1, 273.

Yamaji, T., Ishibashi, M. & Takaku, F. (1985). Atrial natriuretic factor in human blood. Journal of Clinical Investigation, 76, 1705–1709.

Yandle, T.G., Espiner, E.A., Nicholls, M.G. & Duff, H. (1986). Radioimmunoassay and characterisation of atrial natriuretic peptide in human plasma. Journal of Clinical Endocrinology and Metabolism, 63, 72–79.

Yandle, T.G., Richards, A.M., Nicholls, M.G. *et al* (1986). Metabolic clearance rate and plasma half-life of alpha-human atrial natriuretic peptide in man. Life Sciences, 38, 1827–1833.

Zimmermann, U., Schultz, J. & Pilwat, G. (1973). Transcellular ion flow in *E. coli* B and electrical sizing of bacteria. Biophysical Journal, 13, 1005–1013.

Zull, E.S, Smith, S.K. & Wiltshire, R. (1990). Effect of methionine oxidation and deletion of aminoterminal residues on the conformation of parathyroid hormone. Journal of Biological Chemistry, 265, 5671–5676.

