

Conference, San Francisco, CA, USA, 14.03.2019-15.03.2019. Cham, Switzerland: Springer International Publishing Company, pp. 603-615. The final authenticated version is available online at: [https://doi.org/10.1007/978-3-030-12385-7\\_44](https://doi.org/10.1007/978-3-030-12385-7_44)

# Comparison Between Maximal Independent Sets and Maximal Cliques Models to Calculate the Capacity of Multihop Wireless Networks

Maher Heal

Department of Computer Science and Math  
University of Stirling  
Stirling, UK

Email: [maher.heal@cs.stir.ac.uk](mailto:maher.heal@cs.stir.ac.uk)

Jingpeng Li

Department of Computing Science and Math  
University of Stirling  
Stirling, UK

Email: [jli@cs.stir.ac.uk](mailto:jli@cs.stir.ac.uk)

**Abstract**—In this work we compare two models to calculate the capacity of multihop wireless networks. The first model utilizes the maximal independent sets of the conflict graph. The problem in that model is formulated as a linear program. The second model in our comparison utilizes the maximal cliques of the conflict graph using integer programming. We see the second model is much more efficient in calculating the capacity for larger networks. We make no assumption on the interference models and we only model it by assuming a conflict matrix. First, we prove there is a periodic schedule for the flow, by using that we formulate our integer programming model to attain maximum capacity for the network. We consider one source of data and one destination i.e. a single commodity network.

**index terms** - Maximal independent set, Maximal Clique, linear programming, binary programming, maximum throughput

## I. INTRODUCTION

Wireless multihop networks are networks that have no central entity to coordinate the communication between the network nodes such as wifi networks. The nodes are free to join and leave, and due to the limited wireless range they communicate in a multihop manner, which means that two far nodes may exchange data by forwarding the data to intermediate nodes and the data moves from hop to hop until reaching the destination without any central coordination. There are many realizations for such networks with wide range of applications. Such realizations include wireless mesh networks, wireless sensor networks and ad hoc networks. However, the models we deal with are for static wireless multihop networks, i.e. the nodes are fixed without any motion involved. Hence, they are more appropriate for mesh networks and static sensor networks, unlike ad hoc networks which may have moving nodes.

The capacity of multihop wireless network has been the subject of intensive study by the research community. Indeed, as it was shown by Jain et al [1] the general problem of finding the capacity of such networks for a general interference model characterized only by a conflict matrix is np-complete and accordingly no conclusive solution to the problem is possible unless P is equal to NP. Researchers have used information

theoretic approaches and linear, integer and mixed-integer programming techniques to address the problem. In this work we propose a maximal cliques binary programming model which is far efficient than the independent sets linear programming model. Our paper is organized as follows: Section I is the introduction. Section II is the literature review shedding light on some of the research carried out on the problem of maximum capacity of multihop wireless network. Section III is a summary of a maximal independent sets model to calculate the capacity, namely Jain et al [1] model. In Section IV we introduce our integer-programming model to calculate the single-commodity exact capacity of multihop wireless networks. A comparison between the maximal independent sets model and the maximal cliques model is in Section V. Finally, we give our conclusion in Section VI.

## II. RELATED WORK

The capacity of multihop wireless networks is one of the fundamental questions for such networks. An ultimate answer of the question is not feasible unless P=NP because the problem is NP when interference is factor in the puzzle [1]. There have been two approaches to attack the problem. The first approach is information theoretic one, where bounds on the capacity are derived. The second approach is flow models approach. We will summarize some results of the first approach briefly as our main concern is the flow models approach. In the information theoretic approach, usually assumptions about the topology of the network, randomness and homogeneity of the nodes are assumed and only bounds are derived; while the flow models tend to make no restrictive assumptions apart from the interference models used. The seminal work of Gupta et. al. [2] found that for a multihop wireless network of a randomly placed identical nodes the throughput of each node is  $\Theta(\frac{1}{\sqrt{n \log n}})$  assuming a random communication pattern. If an optimal communication pattern is used then each node throughput is  $\Theta(\frac{1}{\sqrt{n}})$ . They used two interference models: protocol interference model which is a binary model such that the nodes are either interfering or not based on nodes locations, and a signal-to-noise interference model which they called

physical model. In this work we assume no restriction on the interference model, but only modeled by a conflict graph to be explained in Section III. The capacity as derived by Gupta et. al. is pessimistic and hence subsequent works searched for alternatives for better bounds. By using percolation theory and assuming pairwise coding and decoding at each hop, and a time-division multiple-access (TDMA) scheme a capacity of  $\Theta(\frac{1}{\sqrt{n}})$  was able to be obtained even under random nodes locations assumption [3]. To optimize the bound some authors assumed using directional antennas, such as the work of Yi et. al. [4] and Peraki et. al. [5]. Our work can be generalized for such scenarios by changing the conflict graph since our models are general for any interference models. A gain in the capacity is also possible by using multi-packet reception (MPR) as proved in [6]. However, in the models we compare, we made no such assumption, in spite of there are some flow models for the capacity studied the MPR scenario [7]. Some authors studied the effect of topology on the network capacity such as [8]. We are studying mainly lattice topologies and random topologies. The impact of traffic pattern was also a subject of studies by considering multicast and broadcast traffic and not only a unicast [9] [10] [11] [12]. we deal only with a unicast traffic, but extensions are possible for other kinds of traffic. A good survey paper of the information theoretic approach in calculating bounds on the capacity of multihop wireless networks is that by Ning Lu et. al. [13].

The other methods that were used to study the capacity are flow models. The first flow model that sparked off a whole research direction using these techniques to calculate the capacity of multihop wireless networks is that of Jain et. al. [1]. We will summarize that model in Section III and we will use it as our base model for maximal independent sets models that calculate the capacity after listing maximal independent sets of the conflict graph. Although the authors discussed two interference models, i.e. the protocol interference model and the physical interference model, similar to those in [2], their model is quiet general to any interference model since it is modeled by the adjacency matrix of a conflict graph. Kumar et. al. [14] studied the problem of maximum capacity under different constraints, namely fairness and energy consumptions. However, their model is based on the geometric properties of three interference models, one of which is the protocol model. Their model is not applicable to the general case of interference characterized by a general conflict matrix. In [15] the authors suggested an algorithm that provides 68% of the optimal throughput in worst scenarios and up to 80% practically. However, their interference model is very limited by considering nodes that can transmit to and receive from one node at a time. They also suggested an extension to a limited version of IEEE 802.11 like interference protocol without specifying how close their found throughput to the optimal value. Here, we are interested in exact throughputs or network capacity. Some authors studied directional antennas and reconfigurable antennas such as [16]. Although we don't refer to that, we assume a general conflict graph which can accommodate for such scenarios. Moreover, the maximum

throughput problem was studied under physical interference model as in [17].

### III. MAXIMAL INDEPENDENT SETS MODELS FOR CAPACITY CALCULATION

We assume we have a network modeled by a graph of  $N$  vertices and  $L$  links,  $G(N, L)$ . The vertices represent the nodes and the links represent the communication channels between the nodes. Interference is modeled by a conflict graph  $H$  where each vertex in the graph corresponds to a link in the network graph, two vertices in the conflict graph are connected if the links in the network graph are interfering, i.e. cannot be active at the same time. See Fig. 1 which shows a 5 node network with the interference zones.  $Link_{12}$  is in the same interference zone of  $Link_{13}$  and  $Link_{24}$  is in the same interference zone of  $Link_{45}$  hence we see them connected by an edge in the conflict graph in Fig. 1-b. By assuming there is one flow from node  $n_s$  to node  $n_d$ , the maximum flow problem is given by:

$$\max \sum_{l_{si} \in L} f_{si} \quad (1)$$

Subject to:

$$\sum_{l_{ij} \in L} f_{ij} = \sum_{l_{ji} \in L} f_{ji} \quad n_i \in N \setminus \{n_s, n_d\} \quad (2)$$

$$\sum_{l_{is} \in L} f_{is} = 0 \quad (3)$$

$$\sum_{l_{di} \in L} f_{di} = 0 \quad (4)$$

$$f_{ij} \leq C_{ij} \quad \forall i, j | l_{ij} \in L \quad (5)$$

$$f_{ij} \geq 0 \quad \forall i, j | l_{ij} \in L \quad (6)$$

$$\sum_{i=1}^{K'} \lambda_i \leq 1 \quad (\text{because only one maximal independent set can be active at a time}) \quad (7)$$

$$f_{ij} \leq \sum_{l_{ij} \in I_i} \lambda_i \cdot C_{ij} \quad (\text{because the fraction of time for which a link may be active is constrained by the sum of activity periods of the independent sets it is a member of}) \quad (8)$$

where  $\lambda_i \geq 0$  is the time allocated to maximal independent set  $I_i$ ,  $K'$  is the total number of maximal independent sets and  $C_{ij}$  is the capacity of link  $ij$ . The objective, Equation 1, is to maximize the outward flow from the source node  $n_s$ . Equation 2 is the flow conservation condition which means the inward flow equals to the outward flow for all nodes except the source or destination. The third Equation 3 states that the inward flow at the source node is zero; and similarly Equation 4 states that the outward flow from the destination node is zero. Equation 5 is a restriction on each link flow to be less than the link capacity, and Equation 6 obviously states each flow is either

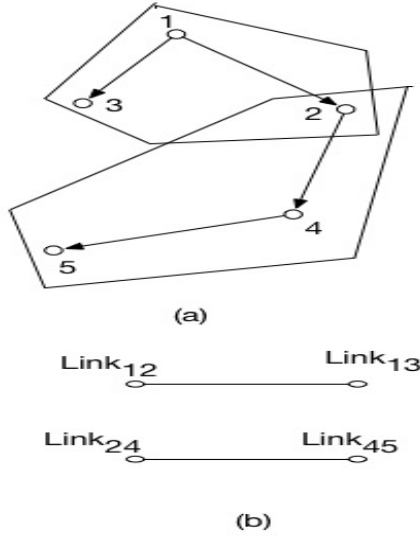

Fig. 1: Conflict graph.(a) A 5 node network with their interference zones, and (b) the conflict graph of the network.

positive or zero. This is a single commodity formulation since we have a single source - destination flow. Equations 7 and 8 are constraints due to interference. Please refer to [1] for details.

#### IV. MAXIMAL CLIQUE MODELS FOR CAPACITY CALCULATION

This section states our integer programming model to calculate the capacity of wireless multihop networks. We firstly state some opening definitions and prove there is a periodic schedule that attains the maximum capacity for the network which is crucial for our model correctness.

##### A. Preliminary Definitions

As before, we assume a wireless multihop network of  $N$  nodes and  $L$  links. The links are interfering according to any interference model, which is modeled by a conflict graph characterized by a conflict matrix (graph adjacency matrix).  $C$  is a column vector of links capacities. The network is a single commodity network with one source  $n_s$  and one destination  $n_d$ .

a) *A feasible schedule of a link*: : it is a set of successive time periods such that in each time period the link is either active (transmitting data) or idle (not transmitting data). However when the link is active in a period, all other interfering links are idle.

b) *A feasible schedule of the network*: : it is a schedule where all links schedule are feasible on the same time scale and the flow conversation rules are satisfied.

c) *Maximum flow of the network*: : it is the maximum flow from  $n_s$  to  $n_d$  such that the network schedule is feasible. See Fig. 2 for illustration of these definitions.

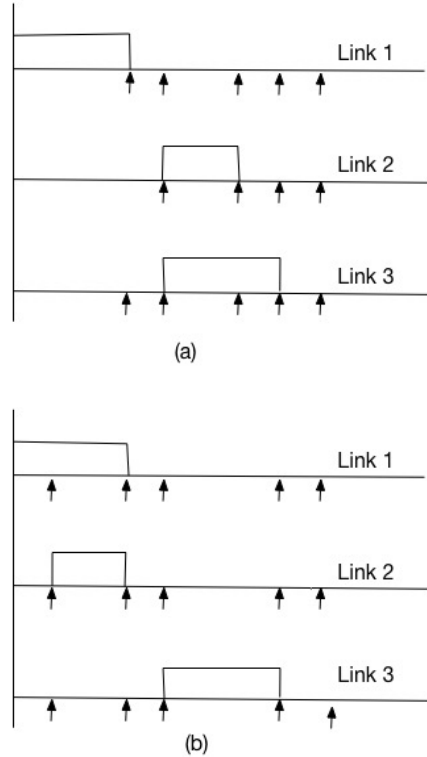

Fig. 2: Link 1 is interfering with link 2, but link 2 is not interfering link 3.(a) A feasible schedule of 5 periods, and (b)infeasible schedule.

d) *Flow of a link*: Let  $\sum_0^t x^i$  is the sum of successful active time on link  $i$  in the period  $[0, t]$  when schedule  $x$  is used, flow of link  $i$  ( $f_i$ ) is defined as:  $f_i = \lim_{t \rightarrow +\infty} \frac{\sum_0^t x^i}{t}$ .

e) *Feasible flow vector of the network*: is an assignment of flows ( $f_i$ ),  $i = 1, 2, \dots, l$  where the schedule of the network is feasible.

##### B. Proof of the Existence of a Periodic Schedule

We prove here that there is always a periodic schedule that attains a maximum flow for the network from node  $n_s$  to node  $n_d$ .

a) *lemma 1*: Let  $g_i = \frac{\sum_{t_1}^{t_2} x^i}{t_2 - t_1}$  be the average of the sum of active periods on link  $i$  in the period  $t_1$  to  $t_2$  when feasible schedule  $x$  is used, and let ( $f_i^*$ ) be the maximum flow of the link  $i$ ,  $i = 1, 2, \dots, l$  when the network flow is maximum, then  $g_i$  is less than or equal to ( $f_i^*$ ) for any feasible schedule  $x$  and link  $i = 1, 2, \dots, l$ .

b) *proof*: Let  $f_i^* = \lim_{t \rightarrow +\infty} \frac{\sum_0^t x^i}{t}$  be the maximum link  $i$  flow when the network flow is maximum.

Now if  $g_i > f_i^*$  then divide the time line into slots of size  $t_2 - t_1$  and use schedule  $x$  in each of these slots, we have  $f_i = \lim_{t \rightarrow +\infty} \frac{\sum_0^t x^i}{t} = \lim_{n \rightarrow +\infty} \frac{\sum_{i=1}^n g_i (t_2 - t_1)}{n(t_2 - t_1)} = \lim_{n \rightarrow +\infty} \frac{ng_i(t_2 - t_1)}{n(t_2 - t_1)} = g_i$ . If  $g_i > f_i^*$ , we have a flow greater than  $f_i^*$ , which is clearly a contradiction since  $f_i^*$  is the maximum attainable flow. Accordingly  $g_i \leq f_i^*$ .

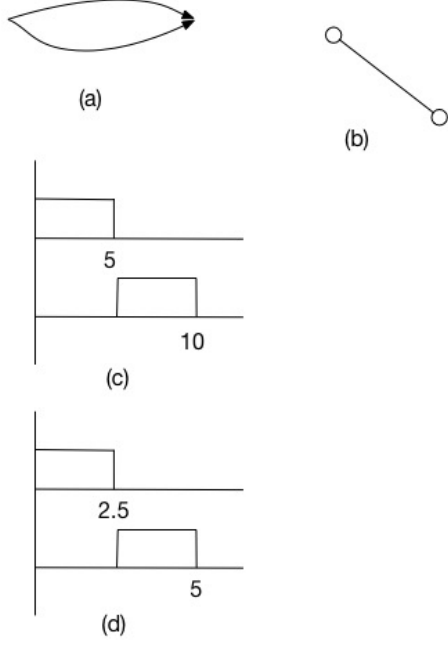

Fig. 3: A schedule that attains maximum flow for two nodes network.(a) The network, (b) The conflict graph, (c) schedule with period equal 10 time units, and (d) the period in c shrunken by factor of 2.

c) *Theorem:* There is always a periodic schedule to maximize the network flow in single commodity or multicommodity wireless multihop networks.

d) *proof:* Let  $f_i^* = \lim_{t \rightarrow +\infty} \frac{\sum_0^t x^i}{t}$  be the maximum feasible flow for link  $i = 1, 2, \dots, l$ . Now divide the time line into slots of size  $T$ , i.e.  $[0, T], [T, 2T], [2T, 3T], \dots$  etc we have  $f_i^* = \lim_{n \rightarrow \infty} \frac{\sum_{j=1}^n \sum_{j-1}^{jT} x^i}{nT}$ . Now if the schedule is periodic in  $T$  that is all what we need and  $f_i^* = \frac{\sum_0^T x^i}{T}$ . In case it is not periodic then based on the Lemma 1, we have the average flow in every  $T$  equals or less than  $f_i^*$ . Hence either  $\sum_0^T x^i = \sum_T^{2T} x^i = \sum_{2T}^{3T} x^i = \dots = f_i^* T$  then replace the schedule of  $[T, 2T], [2T, 3T], \dots$  by the schedule of  $[0, T]$  and by that we have a periodic schedule; or if we have  $\sum_0^T x^i, \sum_T^{2T} x^i, \sum_{2T}^{3T} x^i$  all or some less than  $f_i^* T$  then we have  $\sum_{j=1}^n \sum_{j-1}^{jT} x^i < nT f_i^*$  dividing by  $nT$  and taking the limit as  $n$  tends to infinity we have  $f_i^* < f_i^*$  which is clearly a contradiction. Accordingly, the schedule is periodic.

e) *A remark on the period  $T$ :* It is clear  $T$  can be arbitrary as can be seen from the pervious proof. For example if we take  $T = 10$  time units, we can extend the time scale by 2 or shrink by 0.5 and the schedule used is extended or shrunken proportionally. See Fig. 3 for an example.

### C. Integer Programming Model

Taking the period equals to 1, we can easily have maximum network flow is given by the solution of the following integer

programming problem given that the period is divided into  $n$  equal slots and after dividing the solution by  $n$  and taking  $n$  tends to infinity.

$$\max \sum_{l_{n_s i} \in L} \sum_{r=1}^n C_{n_s i} \theta_{n_s i}^r \quad (9)$$

$$\sum_{l_{ij} \in L} \sum_{r=1}^n C_{ij} \theta_{ij}^r = \sum_{l_{ji} \in L} \sum_{r=1}^n C_{ji} \theta_{ji}^r \quad (10)$$

$$\sum_{l_{in_s} \in L} \sum_{r=1}^n C_{in_s} \theta_{in_s}^r = 0 \quad (11)$$

$$\sum_{n_{di} \in L} \sum_{r=1}^n C_{n_{di}} \theta_{n_{di}}^r = 0 \quad (12)$$

and at each maximal clique  $q$

$$\sum_{l_{ij} \in q} \theta_{ij}^r \leq 1 \quad r = 1, 2, \dots, n \quad (13)$$

$$\theta_{ij}^r \in 0, 1 \quad (14)$$

where  $\theta_{ij}^r$  is the time allocated in slot  $r$  for link  $ij$ ,  $r = 1, 2, 3, \dots, n$ . The first equation is maximizing the outward flow from source node  $n_s$  and equations 10, 11 and 12 are the flow conversation equations and equation 13 is a restriction on  $\theta$  variables, allocated time, in order to have a feasible schedule free of conflicts. We illustrate that by a sample network of five links as shown in the Fig. 4. It is true we need large value of the slots number to confirm converging to the maximum flow of the network, but we can try smaller number of the slots starting by 1, 2, 3, 4, ...etc until we hit the period of the network as we will see for many networks. This will be clear when we discuss the results in section V, and when we apply the algorithm in Procedure I to the network in Fig. 4 at end of this section. Indeed the calculated capacity for whatever number of slots, by Lemma 1, is less than the calculated capacity, when the number of slots is the period of the schedule. Additionally when we use double the period we have again the maximum attained flow. Hence we have the algorithm in procedure 1.

In table I we see the obtained throughput for different values of slots when we use our integer programming model, for  $n=1$  to 10, It can be seen that the throughput is less than 0.4 in all values of slots expect at  $n=5$  and  $n=10$ . Hence it is concluded the period is 5 and the maximum throughput is 0.4. To check we took  $n$  large values, for example when  $n=99$  we found throughput equal to 0.3939 which is close to 0.4. Indeed when  $n$  tends to infinity we gets a throughput equals to 0.4. When we took  $n=100$ , the obtained throughput is 0.4 since 100 is a multiple of 5, i.e. we are repeating the period more than one time.

**Procedure 1** Integer programming algorithm to calculate capacity

- 1: *number of slots* :  $n \leftarrow 1, 2, 3, 4, 5, 6, 7, \dots$
- 2: **if** calculated flow changes and reaches maximum at  $M$  slots **then**
- 3: check flow at slots number  $2M$  and less and more than  $2M$
- 4: **if** flow is maximum at  $2M$  and less at number of slots less and more  $2M$  **then**
- 5: the period is  $M$  and maximum capacity is flow at  $M$  or  $2M$
- 6: **else**
- 7: Keep trying for increasing value of number of slots
- 8: **end if**
- 9: **end if**

TABLE I: Integer programming model throughput for different number of slots  $n$

n	throughput
1	0
2	0
3	0.333
4	0.25
5	0.4
6	0.333
7	0.2857
8	0.3750
9	0.333
10	0.4
99	0.3939
100	0.4

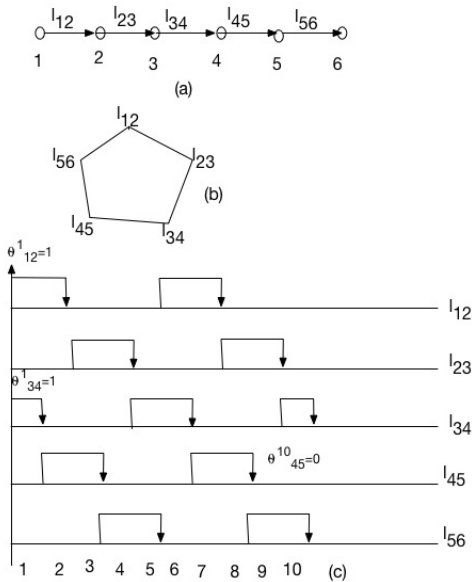

Fig. 4: Example Network. (a) The network topology,  $n_s=1$  and  $n_d = 6$ , (b) the conflict graph, and (c) a feasible schedule that attain maximum flow of 10 slots, with  $\theta$  variables shown for some slots. The period is 5.

V. RESULTS

We run both the maximal independent sets model and the maximal cliques models using MacBook Pro, late 2012, 2.5 GHz Intel Core 5 processor and 8 GB RAM. The networks we run the modes on to calculate the capacity are lattice networks with 802.11 MAC protocol, i.e. the interference at the transmitter and the receiver of the packet and with one source laying at the lower corner and the destination at the upper right corner, See Fig. 5. Transmission range in all networks (d) is 1 and interference range (R) is the same, with a capacity of each link (C) equals to 1. In table II,  $m$  is the length of the side so  $m = 32$  means 1024 nodes, ISMT1,

ISMT2 and ISMT3 are the maximal independent sets listing time, linear solver time and total time respectively. S, CMT1, CMT2, CMT3 and T are the cliques model number of slots used, cliques listing time, binary solver time, total time and calculated throughput, respectively. All times are in minutes. As can be seen from the table the independent sets model can calculate the throughput when the number of nodes is maximum 25,  $m = 5$ . It completely fails when we increase the nodes for 49, 529 and 1024. This failure is due to the excessive time needed to list independent sets as can be seen when  $m = 7$ ; after 22 hours of running the complete set of independent sets is still not complete. The clique model outperforms the independent set model due to the very short time in listing cliques and the bottleneck is the binary solver time; however, it is quite reasonable and when the solver takes excessive time for a slot number you may try a different slot number or tweak the binary solver. The solver we used is cplex 12.7.1 for matlab. In table II we reported the time for some values of  $m$  in an aggregated manner due to space such as  $m = 3$ , but detailed for other values such as  $m = 7$ . The periods found for  $m=3, 5, 7, 23$  and  $32$  are 5, 6, 3, 3 and 3 respectively. Even when estimating the period is hard, the calculated throughput is quite close to the exact value when S is large such as  $S=100$  for  $m = 23$  in a fairly short time. Our last example is a random network of 42 nodes and 188 links (see Fig. 6). The protocol used is 802.11 and hence interference is at transmitter and receiver. It is deployed in an area of 5 X 5 meters and transmission and interference ranges are both 1m. capacity is 1 for each link. The source is the node at the lower left corner and the destination at the upper right corner. After running the maximal independent sets model for two hours we don't see a convergence to all maximal independent sets and hence we couldn't calculate the exact capacity. The time required is expected to be much more than 2 hours. With our Clique model we found a period of 3 and were able to find an exact throughput of 0.3333 in 0.0626 minutes using slots from 1 to 6 and a throughput of 0.33 in 0.0573 minutes using 100 slots.

## VI. CONCLUSION AND FUTURE WORK

We compared two models to calculate the maximum single commodity throughput in multihop wireless networks. The maximal independent sets model gives exact throughput but only for very small networks due to the excessive time required to list maximal independent sets; while the maximal cliques model calculates the exact throughput for far larger networks due to smaller time in listing maximal cliques. By taking a large number of slots, the maximal cliques model gives results very close to the exact value. We are planning to estimate the difference from the exact value for a large number of slots, by considering the the estimated values of throughput for small values of slots when the period cannot be guessed.

## REFERENCES

- [1] K. Jain, J. Padhye, V. N. Padmanabhan, and L. Qiu, "Impact of interference on multi-hop wireless network performance," *Wireless networks*, vol. 11, no. 4, pp. 471–487, 2005.
- [2] P. Gupta and P. R. Kumar, "The capacity of wireless networks," *IEEE Transactions on information theory*, vol. 46, no. 2, pp. 388–404, 2000.
- [3] M. Franceschetti, O. Dousse, N. David, and P. Thiran, "Closing the gap in the capacity of wireless networks via percolation theory," *IEEE Transactions on Information Theory*, vol. 53, no. 3, pp. 1009–1018, 2007.
- [4] S. Yi, Y. Pei, and S. Kalyanaraman, "On the capacity improvement of ad hoc wireless networks using directional antennas," in *Proceedings of the 4th ACM international symposium on Mobile ad hoc networking & computing*. ACM, 2003, pp. 108–116.
- [5] C. Peraki and S. D. Servetto, "On the maximum stable throughput problem in random networks with directional antennas," in *Proceedings of the 4th ACM international symposium on Mobile ad hoc networking & computing*. ACM, 2003, pp. 76–87.
- [6] H. R. Sadjadpour, Z. Wang *et al.*, "The capacity of wireless ad hoc networks with multi-packet reception," *IEEE Transactions on Communications*, vol. 58, no. 2, 2010.
- [7] Z. Wang, H. Sadjadpour, and J. J. Garcia-Luna-Aceves, "The capacity and energy efficiency of wireless ad hoc networks with multi-packet reception," in *Proceedings of the 9th ACM international symposium on Mobile ad hoc networking and computing*. ACM, 2008, pp. 179–188.
- [8] C. Hu, X. Wang, Z. Yang, J. Zhang, Y. Xu, and X. Gao, "A geometry study on the capacity of wireless networks via percolation," *IEEE Transactions on Communications*, vol. 58, no. 10, pp. 2916–2925, 2010.
- [9] A. Keshavarz-Haddad, V. Ribeiro, and R. Riedi, "Broadcast capacity in multihop wireless networks," in *Proceedings of the 12th annual international conference on Mobile computing and networking*. ACM, 2006, pp. 239–250.
- [10] X.-Y. Li, J. Zhao, Y.-W. Wu, S.-J. Tang, X.-H. Xu, and X.-F. Mao, "Broadcast capacity for wireless ad hoc networks," in *Mobile Ad Hoc and Sensor Systems, 2008. MASS 2008. 5th IEEE International Conference on*. IEEE, 2008, pp. 114–123.
- [11] X.-Y. Li, "Multicast capacity of wireless ad hoc networks," *IEEE/ACM Transactions on Networking (TON)*, vol. 17, no. 3, pp. 950–961, 2009.
- [12] S. Shakkottai, X. Liu, and R. Srikant, "The multicast capacity of large multihop wireless networks," *IEEE/ACM Transactions on Networking (TON)*, vol. 18, no. 6, pp. 1691–1700, 2010.
- [13] N. Lu and X. S. Shen, "Scaling laws for throughput capacity and delay in wireless networks? a survey," *IEEE Communications Surveys & Tutorials*, vol. 16, no. 2, pp. 642–657, 2014.
- [14] V. Kumar, M. V. Marathe, S. Parthasarathy, and A. Srinivasan, "Algorithmic aspects of capacity in wireless networks," in *ACM SIGMETRICS Performance Evaluation Review*, vol. 33, no. 1. ACM, 2005, pp. 133–144.
- [15] M. Kodialam and T. Nandagopal, "Characterizing achievable rates in multi-hop wireless networks: the joint routing and scheduling problem," in *Proceedings of the 9th annual international conference on Mobile computing and networking*. ACM, 2003, pp. 42–54.

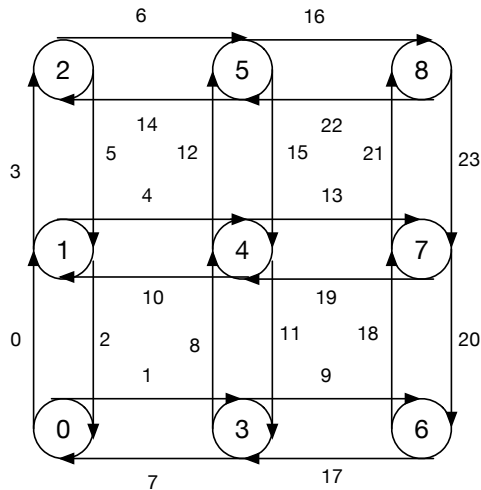

Fig. 5: Lattice networks of 9 nodes ,  $m=3$

TABLE II: lattice networks of different sizes,  $d=1, R=1, C=1$

m	ISMT1	ISMT2	ISMT3	S	CMT1	CMT2	CMT3	T
3	0.0015	6.6887e-4	0.0024	1-8	6.796e-4	0.0103	0.0772	0.5
5	6.5969	0.0071	6.7217	1-12	0.0054	0.239	0.2462	0.6667
7	22*60	-	-	1	0.0201	0.005	0.0253	0
-	-	-	-	2	0.0148	0.0014	0.0162	0
-	-	-	-	3	0.0151	0.0025	0.0177	0.6667
-	-	-	-	4	0.0147	0.034	0.0183	0.5
-	-	-	-	5	0.0183	0.0109	0.0257	0.4
-	-	-	-	6	0.0141	0.0059	0.0201	0.6667
total							0.1233	0.6667
23	-	-	-	100	0.1168	0.1374	0.6600	
-	-	-	-	1-6	0.7834	85.082	88.9233	0.6667
-	-	-	-	100	4.5041	5.452	0.66	
32	-	-	-	1	4.336	0.0108	4.3473	0
-	-	-	-	2	4.0076	0.04	4.055	0
-	-	-	-	4	4.0097	0.2587	4.2806	0.5
-	-	-	-	6	4.1316	0.3451	4.5193	0.6667
-	-	-	-	12	4.2209	0.707	4.9927	0.6667
total							22.195	0.6667
-	-	-	-	105	4.1301	9.3944	13.8378	0.6667

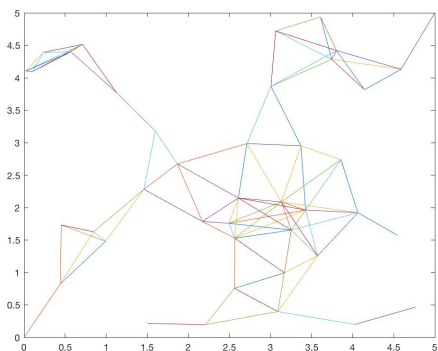

Fig. 6: random network of 42 nodes and 188 links

- [16] Y. Hou, M. Li, and K. Zeng, "Throughput optimization in multi-hop wireless networks with reconfigurable antennas," in *Computing, Networking and Communications (ICNC), 2017 International Conference on*. IEEE, 2017, pp. 620–626.
- [17] P.-J. Wan, O. Frieder, X. Jia, F. Yao, X. Xu, and S. Tang, *Wireless link scheduling under physical interference model*. IEEE, 2011.