

Summer 7-28-2016

Educational Materials in a Private School Setting: An Industrial Ethnography and Document Analysis of One School's Presently-Used Educational Documents

Allison M. Feldman
Kennesaw State University

Follow this and additional works at: <http://digitalcommons.kennesaw.edu/etd>



Part of the [Instructional Media Design Commons](#)

Recommended Citation

Feldman, Allison M., "Educational Materials in a Private School Setting: An Industrial Ethnography and Document Analysis of One School's Presently-Used Educational Documents" (2016). *Dissertations, Theses and Capstone Projects*. Paper 685.

This Thesis is brought to you for free and open access by DigitalCommons@Kennesaw State University. It has been accepted for inclusion in Dissertations, Theses and Capstone Projects by an authorized administrator of DigitalCommons@Kennesaw State University. For more information, please contact digitalcommons@kennesaw.edu.

Educational Materials in a Private School Setting:
An Industrial Ethnography and Document Analysis of One School's
Presently-Used Educational Documents

by Allison M. Feldman

A thesis project submitted in partial fulfillment
of the requirements for the degree of
Master of Science in Information Design and Communication

Department of Digital Writing and Media Arts
College of Humanities and Social Sciences
Kennesaw State University

Kennesaw, Georgia

2016

Dedication

To my dad, who loves to ask when I'm going to get my doctorate.
Your attempts are futile, but hopefully a thesis dedication will make up for it!

Acknowledgements

There are so many people who have helped me along this journey, and I wouldn't have been able to complete this without their continued presence. I've done my best to keep this brief, but with the amount of gratitude I have for those in my life, brevity was nearly impossible.

First, a big thanks to my very patient husband, Steven. Thanks for putting up with my insane hours dedicated to this thesis, and for my constant complaining, especially when trying to plan a wedding in the middle all this craziness. All I had to say was "I'm working on thesis stuff" and you would be incredibly understanding. I'm sure I was annoying and irritable a lot of the time, so the fact that you've stuck with me makes me so happy. A long day, so much!

To my parents: Thank you for always being there for me and supporting me through this crazy decision to go back to school. You always make me feel very proud of what I've accomplished these past few years!

To Dr. Palmer: You've gone from my incredibly intimidating first-semester professor to a colleague and mentor who I can look to for guidance and feedback. You gave me a 55 on my first ever grad school assignment—I'm not sure I'll ever be able to forget that—but it helped get me in gear and really put all that I have into this program. Thank you for always putting up with my constant emails!

To Dr. Bohannon: Three classes and a thesis later, I've learned so much from you throughout this program. Thank you for being a guiding light in my studies, and someone who I can share so many viewpoints with on information design!

To Karyn: Thank you so much for being a rock for me, and for listening to my ridiculous vents about grad school life and about just how long this thesis became. You help make my days go by with a smile on my face, and I sincerely appreciate it.

And to my many friends and family members who've supported me over the years, of which there are far too many to personally name here, thank you as well. I wouldn't be where I am without you.

Abstract

This study utilized an industrial ethnographic framework to perform a document analysis on educational classroom documents presently used at a single small, private boarding school. This school, where students are given an individualized curriculum and experience immersed in technology, frequently uses *Google Apps for Education* to share electronic documents used in the classroom.

Qualitative information was gathered using an instrument created for this study, the Educational Document Design and Information Evaluation (EDDIE) form. EDDIE forms in the areas of Supplemental Documents, Adopted Textbooks, and Lesson Plans were used to evaluate presently-used classroom documents with current information design and educational trends.

The document analysis found that teachers at the school choose and create educational document based on the individual student needs in the classroom. The study demonstrated that teachers need more knowledge and practice in the area of adding stylistic changes to user-created documents to ease document comprehension and understanding for students.

Table of Contents

Dedication	ii
Acknowledgements	iii
Abstract.....	v
Table of Contents	vi
List of Figures.....	viii
List of Tables	ix
CHAPTER ONE: INTRODUCTION.....	1
Background: Brandon Hall School	2
Statement of the Problem	3
Purpose and Significance of the Study.....	4
Research Framework.....	5
CHAPTER TWO: REVIEW OF THE LITERATURE.....	8
Information Design	8
Textbook Decisions.....	15
Implementation of Electronic Textbooks	18
Technology Use in the Classroom	25
Cognitive Psychology and How Students Learn.....	30
Lesson Planning and Pedagogical Design.....	37
CHAPTER THREE: METHODOLOGY	42
Classroom Recruitment.....	42
Document Selection	44
Document Analysis and Data Collection	49
CHAPTER FOUR: ANALYSIS OF DOCUMENTS	52
Classroom A.....	53
Classroom B	63
Classroom C	73
Classroom D.....	84

CHAPTER FIVE: DISCUSSION.....	97
Information Design	97
Textbook Decisions.....	104
Implementation of Electronic Textbooks.....	105
Technology Use in the Classroom	106
Cognitive Psychology and How Students Learn.....	109
Lesson Planning and Pedagogical Design.....	111
CHAPTER SIX: RECOMMENDATIONS.....	115
Supplemental Documents.....	115
Lesson Plans.....	120
Adopted Textbooks	122
CHAPTER SEVEN: CONCLUSIONS.....	125
List of References.....	128
Appendix A: Glossary of Terms	136
Appendix B: Letters of Approval from Brandon Hall School.....	137
Appendix C: EDDIE Forms.....	139

List of Figures

Figure 1. Sample (EDDIE) form for Supplemental Documents.....	49
Figure 2. Sample page of the Study Guide used in Classroom A.....	54
Figure 3. Sample page of the Chapter Test used in Classroom A.	55
Figure 4. Graphic used in the Chapter Test document.....	56
Figure 5. Sample page of Short Answers document used in Classroom A.	57
Figure 6. Sample page of the Calculations document used in Classroom A.	59
Figure 7. Sample page of the Quiz used in Classroom A.	60
Figure 8. Sample page of the Chapter Notes document used in Classroom A.	62
Figure 9. Sample page from the electronic textbook used in Classroom B.....	64
Figure 10. Chapter Introduction page used in the Classroom B textbook.....	65
Figure 11. Sample Lesson Plan page used in Classroom B.....	67
Figure 12. Sample page of Unit Notes document used in Classroom B.....	68
Figure 13. Screenshot of the Quiz form used in Classroom B.....	70
Figure 14. Sample page of Short Story document used in Classroom B.....	71
Figure 15. Sample page of the Final Exam Review in Classroom B.....	72
Figure 16. Sample page of the Chapter Test used in Classroom C.....	75
Figure 17. Image of graphics used in Chapter Test document.	76
Figure 18. Sample slide of Slideshow used in Classroom C.	77
Figure 19. Sample page of Problem Set document used in Classroom C.....	78
Figure 20. Sample page of the Worksheet used in Classroom C.....	79
Figure 21. Sample page of the Scavenger Hunt document used in Classroom C.....	81
Figure 22. Sample page of the Lesson Plan used in Classroom C.....	82
Figure 23. Page from Lesson Plan showing unused column space.	83
Figure 24. Sample page of Lesson Plan used in Classroom D.	85
Figure 25. Sample page of Video Worksheet document used in Classroom D.....	87
Figure 26. Sample page of the Conversation Cards document used in Classroom D.	88
Figure 27. Sample page of the Vocab Slideshow document used in Classroom D.....	90
Figure 28. Graphic readability issues in the Vocab Slideshow document.....	91
Figure 29. Sample page of the Transparencies document used in Classroom D.....	92
Figure 30. Sample page of the Review Sheet used in Classroom D.....	95
Figure 31. A sample of style use in Classroom D.....	100
Figure 32. Short Answers document demonstrating consistent spacing throughout.	101
Figure 33. Short Story sample showing spacing issues.	102
Figure 34. Before and after of sample document redesign on Google Docs.	116
Figure 35. Before and after of sample 4-column lesson plan layout on Google Docs. ..	121

List of Tables

Table 1. Overview of Classrooms and Documents.....	48
Table 2. Overview of Documents in Classroom A.....	53
Table 3. Overview of Documents in Classroom B.....	64
Table 4. Overview of Documents in Classroom C.....	74
Table 5. Overview of Documents in Classroom D.....	85

CHAPTER ONE: INTRODUCTION

Do you learn new information in the same way that everyone around you does? A style that works best for you when interacting with a new document might not work for the person sitting next to you in the classroom. The same idea goes for students in a classroom. Each child will learn best in his or her own way, and as a direct result of his or her own previous experiences in life.

Depending on how a school operates, some of those unique methods of learning can be addressed, creating an individualized education based on student needs. This is one of the overall goals of Brandon Hall School, a private school in Atlanta, Georgia—to help each student learn and grow based on their own educational needs.

However, this individualized education can be compromised when each student in a class is using the same educational materials, such as textbooks, worksheets, or other supplemental materials. If everyone is accessing information the same way, where it is difficult to account for individual learning differences, how can the playing field be leveled so that all students get the information they need in a way that works best for them as individuals? What can teachers do to make sure every student is retaining the information they need to succeed in the classroom?

This industrial ethnography uses a document analysis to perform a cultural assessment of documents within a specific organization. The study will act as a program assessment to determine the effectiveness of current document use in the school.

Background: Brandon Hall School

Brandon Hall School is a small, private day and boarding school with approximately 200 students in grades 6 through 12. Students have the opportunity to receive an individualized curriculum upon enrollment, with careful consideration given to previous course issues or learning difficulties when creating a course schedule. Class sizes are generally small, averaging around eight students per classroom, allowing students and teachers to interact in a more personal environment (Brandon Hall School, n.d., Facts about Brandon Hall).

The school has a strong focus on the use of technology in the classroom, stating in the Mission Statement that a primary goal “is to provide a challenging college preparatory experience immersed in technology” (Brandon Hall School, n.d., The Mission section). In addition, “90% of all books and learning materials are in eBook or electronic format” (Brandon Hall School, n.d., Technology at Brandon Hall School), and many assignments and supplements are distributed digitally through Google Apps. There are some classrooms that are not quite as technology-immersed, resulting in some materials still being distributed in a paper-based format.

Many decisions for the school are made based on this technology-driven environment. As stated on the school’s webpage about technology use, “Our commitment is to ensure we are teaching 21st century skills, encouraging individual exploration and creativity. Achieving this goal means allowing the interest of our students to drive components of our digital curriculum” (Brandon Hall School, n.d., Technology at Brandon Hall School). Opportunities for student success drive all decisions made regarding technology use in the curriculum.

Many students choose to attend Brandon Hall because of the various methods of learning offered to them. “We use technology like iPads, Apple laptops, interactive technologies, electronic projectors and appropriate software to enhance students’ individualized learning, recognizing that students have direct access to information sources” (Brandon Hall School, n.d., Why Choose Brandon Hall School?). With this variety of media, students receive instruction that is unique to their own individual needs and abilities.

Statement of the Problem

Despite this strong focus on technology in the classroom, many students have complained that the digital textbooks cause problems for them. Books chosen by faculty members and department chairs are often distributed through multiple publisher platforms, resulting in each student having to keep track of multiple logins and passwords just to access their books. In addition, with different publishers—and sometimes even within the same publisher—books are often accessed different ways, such as through an interactive website or through a static PDF download of the book. The inconsistencies between textbooks and other course documents tend to frustrate the students, which can lead to lower rates of knowledge retention.

A variation in document accessibility may also cause difficulty for students. While some teachers may choose to distribute supplemental documents through email, others may use Google Drive or hand out physical paper copies. Variations among classrooms may cause confusion for students who must keep track of all documents given to them among different media.

In addition, teachers are each at different levels of document design ability when creating their own documents for the classroom and evaluating potential documents for classroom adoption. Without a design background, teachers may inadvertently create or select documents for their classroom that make knowledge retention and transfer more difficult for students.

Purpose and Significance of the Study

The purpose of this study is to explore current textbooks and supplemental document design and accessibility choices for students at Brandon Hall School. The study will derive from an analysis of print and electronic documents used in the classroom for a variety of subjects between grades 6 to 12. Following the explorations, recommendations will be made on possible improvements for document design and distribution in the classroom.

Research questions. The central research question that this study will aim to answer is, what is the culture-sharing pattern of educational material design choices for students at Brandon Hall School? This study will also address the following sub-questions:

1. What are the common themes in current document choices?
2. Do current document choices and methods reflect the current recommendations for knowledge retention and understanding as laid out in the present literature?
3. How can teachers improve their document choices in the classroom to promote student retention and understanding?

For the purpose of this study, knowledge “retention” can be defined as “the ability on the part of the learner to remember, recognize, and recall information presented to them” (Cook & Klipfel, 2015).

Significance of the study. This study will immediately help faculty at Brandon Hall School better understand how their chosen textbooks and supplemental classroom documents are helping or hindering student learning. With this information, present faculty can examine their current document choices, and determine if they are effective, if other document options exist that may better fit student needs, or if faculty should design their own documents to custom fit student needs. Additionally, in working directly with the Dean of Faculty at Brandon Hall School throughout this study, he can better advise current and future teachers on the most effective methods of document design and distribution in the classroom.

The nature of the industrial ethnography means this study’s recommendations will be specific to the document culture of Brandon Hall School. However, looking outside of this ethnography site, the results of this study can help all educators, in public or private education. Educators of all types can make better choices for textbook and supplemental document selection and design based on current concepts in the related literature. These choices may differ based on the culture of individual educational establishments, but many of the recommendations will remain the same for a wide variety of schools.

Research Framework

According to Bain and Weston (2012), general ethnographic studies in the past have shown that teachers generally “construct their practice in ways that are largely

uninformed by research in the field.” A major goal of this study is to change that generalization, and provide teachers with the background research they need so they can provide students with the best possible classroom documents.

The Review of the Literature in this study covers a large variety of factors affecting student interpretation of classroom documents. These topics include information design, decisions on textbook adoption, the implementation of electronic textbooks, the use of technology in the classroom environment, cognitive psychology and how students learn, and lesson planning and pedagogical design. Each topic plays a role in how teachers provide documents, and how students will therefore interact and interpret them.

Following the Review of the Literature, the study’s industrial ethnographic Methodology chapter explains the research methods utilized. This includes a description of the teacher recruitment and document selection process, as well as an introduction to Educational Document Design and Information Evaluation (EDDIE) forms as the qualitative instrument for the study.

The Analysis chapter goes through classrooms and documents, providing objective, qualitative responses to the topics within the EDDIE forms. This includes EDDIE forms in the areas of Lesson Plans, Adopted Textbooks, and Supplemental Documents.

The Discussion chapter determines the patterns of document choices found in the Analysis chapter, and compares these findings to the current research found in the Review of the Literature. This Discussion follows themes among the six sections of the Review of the Literature.

The Recommendations chapter provides advice for teachers based on the information found in the Discussion chapter. These recommendations are given in the areas of Supplemental Documents, Adopted Textbooks, and Lesson Plans, with subsections created based on the questions asked in the EDDIE forms.

CHAPTER TWO: REVIEW OF THE LITERATURE

In order to fully assess the design of educational documents within a specific setting, it is critical to examine the current literature on a variety of design aspects. This will help ensure that documents and decisions meet the current standards and viewpoints of the industry.

One major question underlies this review of the literature: What are the current best practices when it comes to education and classroom documents? Information design, decisions on textbook adoption, the implementation of electronic textbooks, the use of technology in the classroom environment, cognitive psychology and how students learn, and lesson planning and pedagogical design are all addressed in this review.

While not all aspects of this theoretical framework relate directly to information design and document analysis, some aspects indirectly affect how students interact with documents in the classroom. These indirect factors affect the best information design practices for documents are introduced to the classroom.

The information found in this review of the literature will be used as a basis for the study's qualitative instrument, the Educational Document Design and Information Evaluation (EDDIE) forms. These EDDIE forms and their application to the study are discussed in more detail in the Methodology chapter on page 42.

Information Design

In order for teachers to better understand what works in educational documents and what does not, they should have a basic understand of information design and its

importance in education. Lipton (2007) provides us with one of the most thorough definitions of information design, outlining much of what it encompasses:

Effective information design accomplishes a lot. It helps people navigate and understand the increasingly complex world of facts, figures, directions, and demands. It helps people finish a task, solve a problem, or meets a need. It minimizes or eliminates frustrations. It begins and ends with understanding the people who will use the content and making sure that the content and its presentation and delivery serve them.

Effective information design helps readers to quickly and easily understand the information in front of them. As Waller (2012) states, “Readers are conservative and want to minimize their effort to understand.” When effort is minimized, students can understand and comprehend documents at a quicker pace and with less mental effort.

In educational settings, textbooks should employ effective information design strategies to help students learn efficiently. However, the definition of a “well-designed textbook” is open to interpretation, as individual readers might find different aspects of a textbook as well-designed. One consensus among researchers (Erbaş, Alacaci, & Bulut, 2012) is that a textbook may be considered well-designed if it uses design features that help facilitate “multiple functions for students and teachers.”

The importance of layout. The design and organization of a document will impact how a reader interacts with and understands the information provided. If the layout confuses readers, this will show in their attempted interpretation of the document at hand. In the case of educational documents, including textbooks, worksheets, assessments, and other documents, the presentation of a document can affect how the

reader uses the information to learn (Mikk & Luik, 2005). As Španović (2010) reiterates, “The complicated language of texts, photographs, and graphical design may affect the clear understanding of the anticipated message.”

Children understand and comprehend documents in a much different way than adults because of their personal developmental characteristics. A study by Baek and Lee (2008) determined that “The information architecture of children differs from that of adults in depth, breath, and clarity of contents and logicity.” The authors recommend that the chosen information architecture that is used for children should “be determined in accordance with the cognitive development of users.”

Because of these cognitive differences, document designers should take care to design the information architecture in a way that works best for students, particularly in regards to flexibility. “If a hierarchical navigation system lacks flexibility...navigation becomes inefficient.” Flexible navigation is critical to the design of electronic textbooks. While paper-based documents and textbooks follow a different kind of flexible navigation, this concept should be taken into consideration, as well.

When creating material for their students, teachers must consider how the about and design will affect student comprehension. For instance, when developing examinations separate from what the publisher provides, typographic layout can alter how a student interacts with the assessment. It might affect their reading accuracy or speed, therefore affecting their responses to the questions (Lonsdale, 2014). Every choice made in the creation of a document will have some sort of an affect, whether intentional or unintentional, on each child’s understanding upon interacting with that document.

Creating effective page layouts. Teachers are often responsible for the creation of supplemental instructional documents. As such, they need to design documents that will work effectively for their students. As Burke (2015) argues, “Teachers should think as much about design as they should about instruction, to think like designers as well as teachers.” There are a multitude of ways for teachers who are new to information design to create effective page layouts for their students.

The use of hierarchy to show content importance originated with the ancient Egyptians and the creation of the Narmer Palette. “Relative size definitely suggests a hierarchal significance here: The king is much bigger than any other humans” (Hocks & Kendrick, 2003). By using relative size of images on a stone tablet, hierarchy was shown in that the king was above all other humans. Lipton (2007) reiterates this concept in his book on information design. “We regard elements that are obviously bigger as being more important, and those that are obviously smaller as being less important.” This concept of hierarchy is now considered a basic convention of visual design.

Hierarchy can also be shown “through changing value or contrast, color, position, or shape, or by placing more space around an element” (Apfelbaum & Cezzar, 2014). To make the title of a document the primary emphasis, the designer can place it towards the top of the page, make it larger than the remaining content, make it a different color, and emphasize it by bolding the fonts. Using any or all of these modifications can help an element stand out among the rest, and therefore appeals to the reader as a primary piece of information.

The use of style differences can also show the relationships between elements, as opposed to just making specific elements stand out. “Use style—the size, face, style,

color, and shape of elements—to show their relationships with other elements” (Lipton, 2007). By grouping together items of a similar color or shape, readers can better see related elements.

In addition, using size to make elements more readable encourages efficient interaction and understanding. Studies have shown (Piht, Raus, Kukk, Martin, & Riidak, 2013) that students prefer “big format titles” in addition to “large and clear illustrations.” By making the important aspects of a design stand out with the use of size, readers will more likely interact with these elements before interacting with smaller elements.

Typography is a critical aspect of effective page layouts, where a designer’s choices can affect the legibility of a page. For example, when determining a font to use in a user-created document, “serif should be used to the body of the text and sans serif can be used for headings, captions, and marginalia” (Lonsdale, 2013). In addition, the font choices mixed with spacing concerns can help readers to better understand the information at hand. “Good typography acts as a guide that leads the reader through the content, using space to say, *this goes with this* or *we’re going to take a break here* or *this is something new*” (Apfelbaum & Cezzar, 2014).

Considering the placement of elements within a design helps facilitate understanding, such as with deliberate grouping of elements. “Grouping [of elements] permits an element to have an immediate visual relationship with another element in close proximity” (Elam, 2004). When grouping elements, designers should also pay attention to the white space around grouped and individual elements. Using space between elements effectively can help direct the readers through the content, much like a content map (Apfelbaum & Cezzar, 2014).

Lonsdale (2013) suggests that teachers ensure classroom documents are word-processed instead of handwritten, allow ample space between questions for student responses, and are reproduced at a high quality. In doing so, students have a better chance at successfully demonstrating their level of achievement in the classroom, particularly for examinations.

Visual literacy in teachers and students. In 1996, the National Council of Teachers in English (NCTE) “passed a resolution on the need for visual literacy, announcing in the background section that ‘teachers should guide students in constructing meaning through creating and viewing non-print texts.’” (Hocks & Kendrick, 2003). This resolution demonstrates the need for teachers to understand the need for visual literacy and practice visual literacy concepts to support student learning. When teachers have strong visual literacy abilities, they can also teach students how to use visual literacy to support their own learning.

Aristotle’s three logics of rhetoric—logos, ethos, and pathos—support the importance of implementing visuals within text. As such, teachers must have some sense of visual literacy for when they evaluate and create documents for use in their classroom. “Fluency with images and their use has become crucial to controlling credibility and creating emotional appeal, and even, to some extent, logical appeal” (Hocks & Kendrick, 2003). The effective use of visuals within a layout will help appeal to readers through these rhetorical concepts.

Piht, Raus, Kukk, Martin, and Riidak (2013) state how “it is important to investigate how visual materials supports student learning.” By understanding how students interact with visual materials, teachers can determine which visuals are most

effective for the students' needs, and therefore make better choices on the use of visual materials in the classroom.

Piht et al. (2013) also address how previous knowledge can affect current understanding of visuals within text, an idea discussed in more detail in the “Cognitive Psychology and How Students Learn” section on page 29.

Media literacy, a subset of visual literacy that specifically focuses on multimedia, is quickly becoming one of the “crucial goals in education” (Španović, 2010). As technology progresses, students have access to more multimedia options than ever before. Teachers should understand what multimedia options work best for their students, and take care to match media literacy with the cognitive level of their students.

Graphicacy. Mathematics and science educators face additional problems when assessing the information design of a classroom document, particularly in regards to the visuals that accompany textbook information.

One specific area of textbook visuals is known as graphicacy. Simply put, graphicacy “encompasses both the ability to understand and to create graphics” (Zebehazy & Wilton, 2014). The correct use of graphics in a textbook encourages understanding and retention in the student, particularly in the fields of math and science.

For the sake of this theoretical framework, the use of the word “graphic” requires a clear definition. Lowrie, Diezmann, and Logan (2011) offer one definition: a visual meant for “storing, understanding and communicating essential information” and can include items such as “graphs, maps, number lines, and flow charts.”

Oftentimes, graphics included in texts are too difficult for a typical student at that cognitive level to understand. One type is three-dimensional graphics, which Mikk and

Luik (2005) claim are distracting, often containing a number of fine details that are too complex for students to comprehend. Awareness of graphicacy in teachers will help them to evaluate graphics and determine the appropriate level for their classrooms and students.

The inclusion of graphics in the written textbook material has a direct effect on student understanding. This includes the integration of graphics within the layout. “Graphic illustrations are more effective when integrated with the text of the teaching material” and seem to be “an important factor in learning from printed materials” (Oruç, Uğurlu, & Tokcan, 2010). If done incorrectly, graphic placement within a text can result in a major distraction for the readers. “Students find it challenging to move between text and graphics to the extent that it can disturb their thinking” (Lowrie, Diezmann, & Logan, 2011). Teachers should take special consideration when using course materials with numerous graphics. Graphics-heavy documents should help the readers to understand the information, and not confuse or overwhelm the reader.

Textbook Decisions

Oftentimes, particularly in private schools, the role of selecting a textbook (or possibly multiple textbooks) for a class falls on individual teachers. However, with such a variety of textbook styles, publishers, and methods of access, these decisions can become very difficult and time consuming for the teacher. There are many factors for teachers to consider when researching textbooks and adopting textbooks to their own class curriculum.

The importance of textbooks. Textbooks continue to be a deciding factor in many curricular decisions, and play many roles in the classroom environment.

“Textbooks are both a pedagogical tool as well as a marketed product, textbooks are an instrument for learning as well as an object of learning, and textbooks address both students and teachers” (Erbaş, Alacaci, & Bulut, 2012). Although the methods in which students and teachers access textbooks might change, textbooks remain a staple in the classroom for student learning.

Now, with the onset of electronic textbooks and classroom components, textbooks have become just one piece of a much larger group of classroom educational materials. As Španović (2010) discusses, the textbook now acts as a “complementary source within a multimedia package,” just one source among many that help and encourage students to learn.

Evaluating and selecting a textbook for course adoption. According to Juban and Lopez (2013), surveys with faculty have shown that the most important factor in textbook adoption is content. Content should match with a teacher’s curricular goals, school requirements, and teaching style to be most effective for the student.

Numanoglu and Bayir (2009) suggest that teachers evaluate two main features in a textbook to determine adoption validity: content and conformity to visual design principles. During the adoption process, teachers should ask themselves about how they believe the textbook will work for them. Does the content fit their own curricular goals and requirements, as well as their teaching style? Is the design of the information organized in such a way that students can comprehend and understand the textbook quickly and efficiently? Does the textbook align with the age range of the classroom in

question? These questions, and more, can help teachers to determine if a classroom culture will successfully adopt a specific textbook.

Modern textbook designers now focus on student needs when creating content, and incorporating these needs into textbook designs. Waller (2012) states that these designers “know that students need information to be broken into chunks, and well supplied with headings, illustrations, notes, and meta-level study aids.”

Teachers must ensure that the textbook option they choose will work for both the teacher and the students. Topal, Sarikaya, Basturk, and Buke (2015) wrote that “even if an education program is perfect it will not work if the design, teaching and learning strategies were not adopted by teachers and students.” Additionally, the teacher should select textbooks that will “enhance the learners’ attention and interest in learning” (Štefaniková & Prokop, 2015). Doing so will encourage students to interact more with the textbook. If not everyone in the classroom environment is satisfied with the textbook adoption choice, the textbook will not align with the goals of the course, and the teacher may need to consider other options.

During the textbook adoption process for mathematics and science teachers, it is especially important that textbooks “be investigated in detail in terms of problem posing activities.” This might involve examining the book for “adequate, explicit and tangible problem posing activities” that will help supplement textbook graphics (Kilic, 2013). As previously discussed, effectively designed and placed graphics will help ease the learning process for students.

Two other important considerations for textbook adoption include textbook accessibility and the use of technology in the classroom. The next section,

Implementation of Electronic Textbooks, discusses current research on various methods of textbook accessibility, such as accessing electronic textbooks.

Implementation of Electronic Textbooks

In today's digital age, especially with the growing popularity of tablets (Huang, Chen, & Ho, 2014), electronic textbooks have become much more prominent. However, debate exists as to whether schools should implement print or electronic textbooks in their curriculum. Each type, between print and electronic textbooks, have individual benefits and drawbacks.

A variety of authors have given a definition to what exactly an electronic textbook (also known as an e-textbook, or an e-book for short) consists of. These varying definitions include

- “a package consisting of teaching and learning contents in an electronic format and the computer devices used to access the contents” (Lee & Yau, 2015);
- “book-length publications in digital form, either ‘born digital’ or derived from a printed version” (Browne & Coe, 2012); and
- “a new platform for accessing digital information that preserves the benefits of having electronic reading while providing many of the advantages of paper books” (Kang, Wang, & Lin, 2009).

However, just because a publisher offers an electronic version of a previously print textbook, this does not mean that the two have identical features. Many times, what the publisher considers an e-book might really just be a print book scanned into PDF

form. For these types of e-books, the only digital benefit is the ability to search the text for a specific keyword or phrase (Browne & Coe, 2012).

According to de Oliveira, Camacho, and Gisbert (2014), “The adoption of e-textbooks does not necessarily mean a transition from traditional textbooks to e-textbooks.” Because of this, teachers should consider a number of factors when determining if an e-book is the right option for a particular classroom environment.

Growth of electronic textbooks. As technology develops, so do the offerings of electronic textbooks. While the PDF style of textbooks that Browne and Coe (2012) discuss are still prevalent, many other e-books continue to change how information is given. “Digital textbooks...have evolved into teaching and learning support systems equipped with numerous tools to help learners explore, build, apply, and share knowledge” (Lim, Song, & Lee, 2011).

Now, the growing sales of electronic textbooks demonstrate that schools have begun to implement the structure successfully. According to a 2013 CourseSmart article referenced by Falc (2013), “In 2010, there were over 12,000 e-textbooks available, and now they offer over 90% of textbooks in use today.” Juban and Lopez (2013) also stated that by this year, they expect that sales of electronic textbooks “will make up 18% of total textbook sales.” Should a teacher want to adopt an e-book for their classroom, they have many options available to them to do so. If these e-books trends continue, the implementation of e-books in the classroom will likely become the norm instead of the exception.

Benefits of electronic textbooks. Multiple scholars (Lee & Yau, 2015; Španović, 2010) have recognized that e-books can have major overall benefits to the educational

process. Španović (2010) had this to say regarding the numerous benefits of electronic textbooks:

Contemporary e-textbook design has the power to support the individualization of learning process. When it uses common ways of expression, such as speech, text, still and motion pictures, film, virtual reality, etc., and when it is designed according to the pedagogical conceptions of instruction, electronic textbooks may well become a significant factor for quality technology-based instruction.

Meanwhile, Lee and Yau (2015) believe that e-books “have the potential to address some of the shortcomings of paper-based textbooks.” These benefits provide a basis of solid support for the implementation of e-books in classrooms.

Today, electronic textbooks often include a variety of multimedia features that enhance the student learning experience. Huang, Chen, and Ho (2014) define multimedia learning as “a learning method which integrates words, including texts and narrations, with pictures, including diagrams, charts, pictures, maps, animations, and videos.” A student’s electronic textbook might now include a number of multimedia features to help them learn, including “note-taking tools, memo pads, writing and highlighting tools, messenger services, discussion boards, navigation tools (e.g., bookmarking, page search/scroll, and course selection), screen-capture capabilities, textbook display options, and search tools” (Lim, Song, & Lee, 2011).

Throughout multiple areas of research, students themselves have given their reasoning for a preference towards electronic textbooks, such as the books offering

- “greater flexibility and accessibility than paper-based texts, considering their multimedia-enriched visual appeal, limitless reuse possibility and support for personalized learning” (Sun & Jiang, 2015);
- “easiness to do activities and find information, [and] the possibility to see images and videos” (de Oliveira, Camacho, & Gisbert, 2014);
- “the ease of using an e-textbook and not carrying around a physical textbook” (Falc, 2013); and
- “[providing] for flexible individualized learning” (Španović, 2010).

In addition to student responses, school administrators have given their support for electronic textbooks. As de Oliveira, Camacho, and Gisbert (2014) found in their work, electronic textbooks generally have support due to the fact that they are “relatively cheap, easy to handle, and capable of obtaining usage statistics.” Evidence has shown that all personnel in a school environment—including students, teachers, and administrators—can benefit from electronic textbooks in some way, should a staff member decide to implement them.

Drawbacks to electronic textbooks. Despite the plethora of benefits and features available in electronic textbooks, e-books occasionally fail to operate as anticipated, resulting in missed educational opportunities for both students and teachers.

One of the largest drawbacks to electronic textbook implementation is the difficulty in fully integrating the technology into the classroom environment. As Bauer and Kenton (2005) have found, many teachers are not well-prepared for such an integration: “Fewer than 20% of teachers felt that they were prepared to integrate computer technology into their classroom instruction.”

Students also find it difficult to focus on electronic textbooks at times. Internet-based textbooks often contain “numerous links to unrelated stories and sections that seek to distract or divert the reader” (Waller, 2012). While school can place certain blocks to help prevent this, this may not always be the case, leading to distractions occurring instead of learning.

Much like how students have given their preferred benefits of electronic textbooks, they also cite as many drawbacks to the medium. Some of these found in previous research have included

- “process variables such as student effort, differences in processing, and eye strain from computer screens [leading] to a level of discomfort” (Woody, Daniel, & Baker, 2010);
- “the lack of standardization among e-textbooks” (McNeish, Foster, Francescucci, & West, 2012);
- “the fluid and dynamic nature of digital content compared to the more consistent and predictable nature of information on paper” (McNeish et al., 2012);
- difficulty “learning, retaining, and concentrating while in front of a computer” (Falc, 2013);
- “[making] it harder for readers to ‘retrace their path or locate ideas which at first seemed irrelevant but now need more attention’” (Falc, 2013);
- “[difficulty finding] specific chapters in the text or [locating] particular words” (Kang, Wang, & Lin, 2009); and

- “insufficient computer skills, lack of experience...and technophobia [creating] barriers to e-book use” (Browne & Coe, 2012).

These difficulties, among others still presented in the research, demonstrate that e-books still have a long way to go before becoming an end-all textbook solution. Teachers considering the adoption of e-textbooks need to consider these myriad drawbacks. After weighing the benefits and the drawbacks, they must determine if they still wish to move forward with the implementation of e-textbooks.

Students’ preference of paper-based textbooks. Despite the consist growth, offerings, and cited strengths of electronic textbooks, there are still many students who prefer paper-based textbooks. “Although advocates of digitized information believe that millennial students will embrace the paperless classroom, this is not proving to be the case” (McNeish et al., 2012). This preference adds further difficulty to the decisions that teachers must make regarding the implementation of electronic textbooks.

According to a recent study involving more than 400 university students in four countries, “92 percent preferred paper books instead of e-books” (Derla, 2016). The author of the study stated that “young people are resistant to e-books because they say they are distracted and they had to deal with headaches and physical discomfort such as eyestrain” when reading e-books, and that “there really is a physical, tactile, kinesthetic component to reading” that e-books do not account for.

In fact, some students will choose to spend more money just to have access to this print textbook. A 2010 study (Woody, Daniel, & Baker) demonstrated that “90 percent of students who were given the option of purchasing an e-book or a more expensive

textbook did not purchase the e-book, despite easy access and an in-class demonstration of the e-book.”

McNeish, Foster, Francescucci, and West (2012) have extensively researched students’ preference towards paper-based textbooks. They cited a variety of reasons for this preference:

- “Students use the tangibility of the paper textbook as an information-seeking aid, as it is easier to identify their page location within the paper textbook compared to the e-textbook.”
- “The paper textbook helps...to avoid the distractions of being on the computer of the Internet, the temptations associated with checking email, Facebook, or surfing the Web for unrelated content.”
- “With a paper textbook, students feel they have more choices for when and where they can access (e.g., when they are without access to a computer, software, or the internet), and the length of time they are able to access the content, compared to an e-textbook that expires when a course ends.”
- “Students believe that they learn more when studying from paper textbooks. Moreover, paper textbooks allow students to manage content in whatever way they wish to study the material.”

Other researchers (Browne & Coe, 2012; Falc, 2013) have encountered similar results in their research, finding that students see e-books as “clumsy” and “difficult to navigate” (Browne & Coe, 2012), as well as prefer “the security of having a print copy of the textbook” (Falc, 2013).

Overall, while students do appreciate different beneficial aspects of electronic textbooks, many students will continue to use paper-based textbooks. When considering implementation of electronic textbooks, teachers must also consider the fact that some students will not learn as well from e-books as they might from the traditional paper-based textbooks.

Technology Use in the Classroom

According to the research by Collins and Halverson (2009), “technology fosters... a more hands-on, activity-based instruction. Computers are highly interactive and provide the learner with a wide assortment of computer tools to accomplish meaningful tasks.” Because of this, it makes sense that more classrooms have integrated technology and electronic textbooks into the curriculum. However, this integration should be done in such a way that truly benefits both students and teachers throughout the learning process.

As the increasing technology trends continue, so does the use of electronic devices in the classroom. For instance, according to Butean, Morar, Moldoveanu, and Alenandru (2015), in the area of tablet use, “the number of children who are using these devices are going up every year by at least 20%.” As students continue to use these types of mobile devices in the classroom, the opportunities to include technology in the curriculum will grow as well. This rise will likely contribute to “the development of new methods of learning and teaching” (Španović, 2010), as well.

Accessing digital documents. The method in which a student accesses digital documents in the classroom will have a direct correlation with their experience. For

instance, if a student accesses their textbook or other document through an e-reader or smartphone, this experience will differ from when a student accesses the same document on a laptop computer. “Users of e-readers or smartphones have a restricted view, and evidence is appearing that suggests that currently available devices are struggling for acceptance by readers whose tasks are not simple and linear” (Waller, 2012). Many times, document designers cannot plan for these different devices used for access, distorting the view and thereby altering the experience.

Students tend to experience difficulties when accessing their resources, which results in frustration on the part of the student. One of the listed drawbacks to electronic textbooks in the classroom was inability to access textbooks due to a lack of internet connections. Should these disruptions become frequent, students may get frustrated and develop a negative view of this resource accessibility.

Technology can and does fail, such as in the case of attempting to access digital classroom documents. This can affect the learning experience should a school implement a technology-based curriculum. Bauer and Kenton (2005) recommend developing a backup plan in the result of a failure to access documents, for both students and teachers.

Methods of instruction outside the textbook. The textbook is only one method of instruction typically used in the classroom. However, with the rise in availability of Internet access, teachers should consider the use of non-textbook resources to supplement the textbook, or even replace the textbook entirely. Doing so, as Bryce (2011) suggests, can help students to “connect the text to other texts and issues in the real world.” In addition, de Oliveira et al. suggest that “if you have [external resources] well-structured, you can find it all on the web,” therefore reducing cost to the school.

Wikipedia, while often getting a negative connotation for use in the classroom, has become a strong resource to supplement textbook learning. Saparova and Nolan (2016) has this to say on the positive aspects of using Wikipedia in the classroom:

Students found Wikipedia to be extremely helpful for obtaining background understanding of a topic and determining the direction of further research. Among Wikipedia's features that, according to students, promoted information acquisition and processing were (1) readable font, visible headings, clearly demarcated sections, and an abundance of easy-to-use hyperlinks that allowed students to look up the meaning of unknown words...(2) topic summaries at the beginning of each article; and (3) images embedded in the content pages.

The authors continue their approval by stating that, "Any allegedly questionable quality of information in Wikipedia could be counterbalanced by efficient access to a broad range of information." Students can access Wikipedia to gather more information on topics covered in the classroom, supplementing what they learning with knowledge they choose to gain outside the classroom.

Frieson (2013) is another such scholar who supports the use of Wikipedia for education, due to the "inventive" nature of the site, "allowing learners—in addition to teachers and other experts—to quite literally build 'textbooks' of their own." Teachers can create their own Wikipedia pages, called Wikispaces, that they can use for individual classes to supplement classroom materials.

Another non-textbook option available for integration into the classroom experience is *Google Apps for Education*. Logofătu & Vişan (2015) discuss the benefits

of adopting *Google Apps for Education* in classroom, describing the venture as “a free cloud-based messaging and collaboration platform that includes mail, calendaring, IM, as well as Web-based collaborative documents, spreadsheets, presentations, and site,” including applications such as “Gmail, Google Groups, Google Drive, Google Plus, [and] Google Classroom.”

One major advantage to the adoption of *Google Apps for Education* in the classroom is the level of accessibility of documents, due to the cloud-based technology structure. “[Students and teachers] can work from anywhere, on any kind of device (computer, laptop, tablet, smartphone) that is connected to the internet and you can share and collaborate” (Logofătu & Vişan, 2015). When students save documents and assignments on the digital cloud, students worry less about bringing necessary supplies to the classroom on a daily basis. This results in a stronger focus on instruction during class.

Some scholars (Lee & Yau, 2015) have even proposed to combine *Google Apps for Education* with e-textbooks. They created a “scenario in which people can use Google Apps and Office365 through e-textbooks to provide a ubiquitous platform for collaborative learning among students.” While still in the future, ideas such as these demonstrate that Google Apps, cloud technology, and electronic textbooks can collaboratively promote a technology-integrated classroom that promotes the positive use of technology in education.

Challenges to using technology in the classroom. One of the biggest issues to a technology-immersed classroom is providing students with the necessary, up-to-date hardware needed to access their documents. Rapid changes to technology can cause further issues to this requirement, as Amirault and Visser (2015) found in their research.

Every time a classroom adopts a new technology, students and teachers both must learn the new devices or platforms before they become an effective educational resource, resulting in what the authors call an “update cycle.” In addition, “Rapid changes to technology in such a setting can force extensive changes in pedagogy, instructional delivery, and desired learner outcomes.” Any major changes to technology, pedagogy, delivery methods, and outcomes will have a direct effect on the overall learning environment.

Attempts to integrate technology into a classroom may cause unneeded stress on the teachers in said classrooms. Bain and Weston (2012) explain some of these negative effects on teachers following integration:

Those efforts [to innovate, reform, and change classrooms] push teacher to or beyond the limits of their individual schemas. The resulting cognitive overload diminishes their capacity to invoke complex responses (e.g., the differentiation of learning experience) to classroom problems and increases the likelihood that they will rely on older and simpler knowledge (e.g., extra help and test retakes) to guide their teaching. The overload contributes to high levels of stress and burnout among teachers.

In addition to these stressors, many teachers may revert to older ways if technology in the classroom should fail, or not go as expected. This, in turn, can greatly alter the educational experience, and may result in a complete change in how students access their documents inside and outside the classroom (Lagrange & Erdogan, 2008).

Cognitive Psychology and How Students Learn

In order to determine the best educational resources for students, teachers should understand how students learn best, and the cognitive psychology behind why they learn in these ways. According to Oxford dictionary, and as cited by Logofătu and Vişan (2015), to learn means “to gain or acquire knowledge of or skill in (something) by study, experience, or being taught.” Another definition from Cook and Klipfel (2015) defines learning as “a change in the learner’s knowledge.”

Learning is more than a student simply understanding a concept. For a student to have truly “learned” a topic, they need to be able to pull that concept back from their memory, and apply it “to new contexts and situations” (Cook & Klipfel, 2015). By understanding what it means for a student to truly learn new material, teachers can create effective assignments and assessments that focus on student recall.

Understanding new material. The basis of education is teaching new material to students throughout their time in school. As they are always learning new materials, teachers should understand how their pedagogical choices and document decisions affect the learning of said new material.

Erceg and Aviani (2014) have found that the information teachers provide to their students, and what is absorbed and fully learned by the students, are often very different from. Teachers should understand that it is very easy to “significantly overestimate students’ understanding,” and should adjusting their instructional plan and educational documents accordingly.

Levels of mental effort can have a direct effect on how students learn and if they can learn material as intended. Saporova and Nolan (2016) define mental effort as “the

cognitive capacity allocated by the learner when working on a task.” If a student requires too much mental effort to learn a concept, they will overload their cognitive capacity. Many things can contribute to a student reaching the limits of their cognitive capacity, including “figuring out the lesson to be learned, figuring out what it means, and overcoming barriers from organization and presentation.”

Cook and Klipfel (2015) found that “When people are confronted with too much information to process, they turn to a variety of coping behaviors to limit information input (e.g., tuning out, satisficing).” Once students reach that point of information overload and turn to coping behaviors to lessen mental effort, it can result in the student not fully learning the concept at hand.

Document length is just one factor that can have a direct effect on mental effort and the resulting learning process. Farkas and Raleigh (2013) found that “many people, especially digital natives, prefer to read large numbers of short documents such as text messages and social media posts rather than longer documents.” In a technology-driven classroom environment, by understanding that the students will likely learn new material better by using shorter documents, teachers can apply this knowledge to their instruction and reduce the mental effort exerted by their students.

Learning styles and factors. Going by a definition provided by Bhagat, Vysal, and Singh (2015), learning styles are “the composite cognitive, affective, and physiological characteristics that are relatively stable indicators of how a learner perceives, interacts with and responds to the learning environment.” Numerous factors, including a student’s age and awareness of learning styles, can affect a how they learn, interpret, and understand new material in the classroom.

Studies have shown that a student's age affects their own unique style of learning. "Older students show greater ability to differentiate various learning strategies, conceptions, and orientations than younger students" (Topal, Sarikaya, Basturk, & Buke, 2015). Because of this, any selections made for the classroom should take the students' age into consideration, making sure that the material is appropriate for a student of that age to understand. As students grow older and work their way through their education, their learning styles may shift accordingly.

Students aware of their own learning styles gain many benefits for the classroom. Bhagat et al. (2015) state that a student's awareness of their own styles "create a better learning environment by enabling [them] to use appropriate strategies" in a given situation. "Students with more developed competencies in diagnosing their personal learning needs and knowledge acquisition can draw upon these same capacities in informing the group's learning needs and correcting misconceptions" (Lee, Tsai, Chai, & Koh, 2014). Once students understand how they learn best, they can apply this information to adapt to varying methods of instruction, and acquire the knowledge they need from the lesson.

Further, the teacher's awareness of a student's learning style can also provide some benefit to the educational experience (Bhagat et al., 2015). "Teachers have the opportunity to discover students' problem solving strategies and to adapt to the students' way of thinking during the active learning process" (Erceg & Aviani, 2014). Once both students and teachers know how to apply individual learning techniques, they can work together to provide the best experience and materials for that student to learn the material effectively.

However, teaching to individual learning styles may not benefit learning as teachers might anticipate. Some studies have found that many students are quite alike in how they learn. “Cognitive psychology has found that almost all human brains share important similarities in terms of how they absorb and process information,” and that students “are more alike than different in how they learn” (Cook & Klipfel, 2015). Bhagat et al. (2015) have reiterated this idea, stating that “Individualization of instructional method does not contribute significantly to learning outcomes” when addressing the unique learning styles of students. Teachers will have to determine if individualizing a lesson based on learning style will sufficiently support both the student and the educational goals of the lesson.

“Learning styles and preferences are present in all learners, not just in those with special needs; the multiplicity of methods and the variety of methods offered through [Universal Design for Learning] can provide universal academic access to all” (Courey, Tappe, Siker, & LePage, 2012). The basis and benefits to Universal Design for Learning is discussed in more detail on page 39.

Including elements of play. Educational games and the inclusion of elements of play are one way teachers can help students learn in a unique way. “Learning through play is a concept encountered in education and psychology that describes playing as a method for developing social and cognitive skills, emotions, and self-confidence required for every learning task or activity” (Butean et al., 2015).

As evidenced by Cheng, Su, Huang, and Chen (2014), involving play into the curriculum can encourage children to actively participate in the learning process, which can serve as “an engine for learning.” When using educational games, students can

“monitor and evaluate their own learning and take the necessary steps to meet their learning styles.” In addition, educational games help students to apply concepts to real-life situations and problems. “Games often offer a virtual environment with lifelike situations wherein students can practice over and over again without cost or penalty.” In addition, Cook and Klipfel (2015) note that “the introduction of a puzzle or a problem to be solved immediately grabs people’s attention, as they perceive that there will be something interesting and worthwhile involved in the process.”

Diezmann and Lowrie (2012) discuss how the prevalence of technology and play in the classroom can positively contribute to learning, particularly in regard to spatial thinking. The authors suggest that “three-dimensional games that include virtual avatars can provide students with opportunities to learn about spatial orientation in a game environment.” As technology becomes more frequently integrated into classrooms, teachers can develop unique ways of including play and games to supplement and encourage the learning and recall of new material.

However, Cheng et al. (2014) do note that “the playfulness aspect of educational games can be a double-edged sword...If the level of play is too high, students will learn less from the experience.” Students also might “require a longer time to complete tasks and spend too much time and effort on nonproductive activities because of over-involvements in the game play,” a similar problem to what many students experience when using electronic textbooks in the classroom. Should teachers choose to involve play and educational games into their curriculum, they must find a balanced level of play that works best for the students’ productivity and retention.

Previous experience and the effect on learning. Previous experiences, which are out of the control of teachers and designers, can also have an effect on document interpretation by students. Kostelnick and Hassett (2003) are two such scholars who support this concept, bringing the ideas of ecological theory and the effect on information design and interpretation.

According to ecological theory, every experience and individual has will have an effect on their current experiences. As a result, “Every person...perceives his or her environment differently.” Previous experiences will affect how a student might interact with a given document, or even a specific image, sentence, or word. The authors also state the effect of physical and mental state on an individual’s document perception and interpretation: “Because meanings must belong to specific individuals, conventional meanings are open to interpretations that are individual and particular to designers and readers.”

Weinstein, Legate, and Przybylski (2013) also support these theories when it comes to psychological experiences. As they write, “Positive psychological experiences may relate to, but do not equate, evaluations of beauty in the physical world.” A student who has had pleasant experiences with mathematics, for example, might have more positive psychological experiences and see a document as more aesthetically pleasing than a student who has continually had negative mathematics experiences.

Other factors affecting student learning. Oftentimes, students will encounter other external factors that might affect how they learn and how they interact with educational documents. Two of these major external factors include mood state and emotion when learning and interacting, and motivation and achievement goals.

Mood states can affect how a student interacts with an assigned document. Jokinen (2014) found that students commonly enter into an educational interaction “with an underlying emotional state, or a mood” that can affect the experience. These mood states and emotions can ultimately affect how students interact with a given document in the classroom. “Mood and psychological states can influence perceptions, memory, and judgements of attributes like physical attractiveness” (Weinstein, Legate, & Przybylski, 2013). A student in a positive mood may interpret a document very differently from a student in a negative mood interacting with the same document.

Similarly, students with positive moods will be much easier to persuade than those with negative moods (Mejía, 2013). Because of this, “visual communication designers should consider the significance of human differences such as visual intelligence and mood for adequate interaction.” However, designers of documents, including publishers and teachers, should be aware of the difficulty in controlling the mood state that a user experiences when they interact with the document.

Achievement goals, another external factor affecting student learning, often involve one of two types: “Learning/mastery goals, which are focused on the development of competence through mastery, and ego/performance goals, which are focused on the demonstration of competence relative to others” (Fryer, Ginns, & Walker, 2014). A student’s motivation and goal type can affect how they encounter a given document at a specific time.

A variety of factors, whether positive or negative, can affect a student’s motivation and educational goals, such as “prior experiences, achievement history...parents’ goals or beliefs...and classroom structures” (Fryer, Ginns, & Walker,

2014). Any number of situations in a student's life can alter their classroom experience, which is something that teachers cannot adequately prepare for when considering how students might learn in the classroom.

Conversely, negative experiences can affect goals and motivations within document interaction. When students encounter "obstructions in the interaction," negative mood states such as frustration, anxiety, and confusion are more likely to occur, affecting the experience (Jokinen, 2014). This change in state can then change a student's goals and motivation for that particular interaction.

While educators cannot control a student's interaction with the learning experience on a given day, they can attempt to plan for a variety of factors. By considering how different factors might affect an interaction, a teacher can develop a different plan for the student that still achieves the same learning outcomes.

Lesson Planning and Pedagogical Design

A strong pedagogical design for classroom instruction frames how students will interact with documents. However, there is much to consider when developing a plan for instruction. For pedagogy to be truly effective, Cook and Klipfel (2015) state that teachers should understand how their students learn best, and create an instructional plan that fits accordingly. Once a teacher determines the best methods of instruction for their students based on what they expect the students to learn, they can then plan for "instructional materials, methods, and assessments" (Courey, Tappe, Siker, & LePage, 2012) and can develop an effective lesson plan.

Lesson planning. Developing an effective lesson plan for students begins with understanding student needs and applying that to pedagogical goals for a given course. This understanding of needs and expectation includes evaluating what students may already know, and being aware of the difficulties they face in the content area. (Diezmann & Lowrie, 2012).

Lesson planning should include informing students of why certain information is being taught. Cook and Klipfel (2015) argue that although the student may find the material interesting, understanding why information is presented in a certain way will have an impact on their learning. Fryer, Ginns, and Walker (2014) support this initiative, stating that, “The ‘why’ of content of instruction should not be lost in the instruction of the ‘what.’” When students understand the “why” of a specific lesson, they can apply this to their own learning needs and adjust appropriately.

Multiple authors (Burke, 2015; Cook & Klipfel, 2015) discuss the benefits to creating a lesson plan that only focuses on two or three objectives per class period. Doing so will help students to retain an appropriate amount of information (Cook & Klipfel, 2015) and ensure that objectives are cohesive and have a “logical connection to each other” (Burke, 2015). By limiting the amount of information that students receive in a single lesson, students are less likely to experience a mental overload, and can better focus on the information taught in that lesson.

Teachers should consider the use of student collaboration to help promote understanding and knowledge development, particularly in the case of high school students. Young and Luttenegger (2014) discuss the benefits of include collaborative assignments in the lesson plan. “Teachers will have an easier time in their classrooms if

they can harness the energy that peer groups bring to a class. Students often learn better from each other than from the teacher.” These benefits of collaboration can be further enhanced through the previously discussed implementation of Google Apps for Education in the classroom environment, encouraging students to collaborate through a digital platform.

Planning for STEM courses. As evidenced by the work of Ceylan and Ozdilek (2014), “Science, Technology, Engineering, and Mathematics (STEM) literacy is an important element in science related programs of the 21st century.” Since the development of the STEM learning movement, it has quickly become one of the biggest movements in PK-12 education. Because of this emphasis on STEM learning (or STEAM learning, for those schools choosing to include the Arts in this area), teachers in these course areas have additional considerations for their lesson planning.

A focus on STEM education can benefit students on many levels. Ceylan and Ozdilek (2014) have further proven that “STEM education has been effective on learning and accomplishment of learning objectives.” The effective teaching of STEM courses can have a direct impact on how students learn and apply knowledge to other course areas, and how they learn with the educational materials they are provided with in these classes.

Universal Design for Learning (UDL). According to McGhie-Richmond and Sung, (2013) Universal Design for Learning (UDL) is “a blueprint for creating flexible goals, methods, materials, and assessments that work for everyone” in the classroom, regardless of learning style or needs. The major benefit to the implementation of UDL into lesson planning is that it helps teachers plan to meet the needs of a variety of student learners. This can be done without having to go back and change lesson plans to meet

individual needs later in the year if it is determined that the current plans do not work as expected (Courey, Tappe, Siker, & LePage, 2012).

The pedagogical basis behind UDL is that it facilitates “[bringing] students together as a community of common learners” (McGhie-Richmond & Sung, 2013). UDL allows students to be challenged at their own personal level, but in a way that ensures they still learn the same material as every other student in the classroom.

UDL can support a number of instructional methods in the classroom, including “curricular materials, technologies, and instructional strategies that provide numerous means of representation, expression, and engagement” (Courey et al., 2012). The authors add that offering students multiple methods of participation and assessment can benefit both students and teachers. By encouraging these varying “means of representations, expression, and engagement,” students can follow the learning path that best suits their own personal needs, while still resulting in the same educational outcome needed to complete the lesson.

UDL is a lesson planning option best suited for teachers who anticipate having a classroom with a variety of student learning needs. By understanding student differences in the classroom and anticipating their needs, the early application of a UDL framework can ease the instructional process for both students and teachers.

Problem-Based Learning (PBL). Following their research, Topal et al. (2015) outlined what they believe are the basic, essential characteristics of a Problem-Based Learning (PBL) instruction method:

Learning needs to be student-centered and has to occur in small student groups under the guidance of a tutor as a facilitator....Acquisition of

essential knowledge, use of knowledge in clinical contexts and self-directed learning are the objectives of PBL. Students learn efficient problem-solving, independent learning, and learn to monitor themselves as well as by teamwork.

PBL assists students in developing a variety of skills needed for effective learning, including the acquisition of specific skills needed to solve a problem, communication skills, and teamwork (Topal et al., 2015). Similarly, Saparova and Nolan (2016) state that PBL encourages self-direction and self-regulation among students in the learning environment.

One of the criticisms of PBL brought up by Topal et al. is that “students in PBL gained slightly less knowledge” as opposed to standard instruction. However, of this knowledge acquired, students generally could recall more of this limited knowledge. PBL is an option that would be well-suited for teachers looking to lessen the breadth of instruction, but focus on the depth of knowledge acquired.

This Review of the Literature examined the current trends in information design research and the applications to educational documents. The Methodology chapter that follows describes the classroom recruitment and document selection process, as well as introduces the Educational Document Design and Information Evaluation (EDDIE) forms as the qualitative instrument for data collection.

CHAPTER THREE: METHODOLOGY

This chapter provides a description of the research methods utilized to study the patterns of document design and accessibility at Brandon Hall School. The completion of a thorough literature review encompassing all areas that might affect document comprehension provided the framework for this qualitative research methodology.

This methodology includes a description of the teacher recruitment and document selection process. This is followed by the introduction of Educational Document Design and Information Evaluation (EDDIE) forms as the qualitative instrument for this study, as well as details on the document analysis process.

Throughout the study, I myself acted as the key instrument for qualitative data collection. For the sake of this study, “qualitative data” refers to the qualitative information derived from document analysis instruments. I collected and analyzed all data at the industrial ethnography site, Brandon Hall School, to ensure the study stays true to the specific school’s culture. Throughout the entire study, I had no interaction with students, and their personal document preferences had no bearing on the study.

Classroom Recruitment

To recruit teachers and documents for the study, the Dean of Faculty and Brandon Hall School emailed all faculty members with details on the study. These details included a copy of the study proposal and teacher participation instructions. Those teachers willing to participate in the study replied to the email stating their interest in volunteering classroom documents. They received instructions to share as many different documents as they wanted, and to leave comments on how students would typically receive and

resubmit each document, when applicable. Teachers then volunteered their unused classroom documents for use in the analysis. Teachers shared digital documents via Google Drive or email, and shared documents with no digital counterpart as a physical paper document.

The Dean of Faculty acted as liaison to ensure teacher anonymity. Teachers shared their classroom documents and corresponding comments with the Dean of Faculty, who then shared the documents and comments with me. The Dean also sent information regarding the course subject and the typical grade level of students enrolled in the course. To protect the study from possible bias against teachers, the Dean removed any reference to a teacher's name prior to my acquisition of documents. Four teachers volunteered their time and shared classroom documents with the Dean of Faculty.

Collection of classroom documents. For this study, I define a classroom document as any unused document that a teacher has used in the classroom. With the exception of lesson plans, all classroom documents are documents used by students in some way in the classroom, either as an assignment or a reference. While students do not directly use the lesson plans, I included these documents in the study because a teacher's interpretation of a lesson plan can have a direct effect on the classroom environment and student learning ability.

Documents provided by the four teachers included lesson plans, textbook pages, quizzes, chapter tests, final exams, text reviews, chapter notes, daily assignments, slideshows, and more. These documents include a mix of both teacher-created and publisher-provided documents. Teachers submitted only blank documents for the study, resulting in no ties to student names or student work used in the classroom.

Teachers sent a variety of documents for a single course that they teach, regardless of how many times they teach that course in a day. They volunteered multiple types of documents from their classroom, spanning their entire curriculum and school year. There was no limit to the number of documents teachers could share for the study; however, the Dean of Faculty informed teachers that not all shared documents would be included in the final analysis and assessment.

Document Selection

The document selection process involved determining the value of analysis for each document. I determined value of analysis by answering a number of questions about the document under four themes. These questions and rationales to determine document analysis value are explained in further detail in the “final document selection rationale” subsection below.

No more than six document types were selected for each classroom analysis. For the sake of this study, a document type refers to the overarching purpose of document use in a given classroom. For example, a quiz and a test both assess information retention in the classroom, but serve a different purpose and have a different effect on student success in the course (i.e., a test will hold more value in a student’s final grade than a quiz, which typically focuses on a smaller amount of information). Therefore, quizzes and tests are unique documents types, and one of each might be included in a classroom analysis. However, multiple variations of a quiz were not considered, as both versions of a quiz will serve the same purpose and value in the classroom.

In some cases, teachers volunteered more than six documents. For these classrooms, I narrowed down the documents to six with consideration to the documents I felt were most in need of analysis. If a teacher sent multiple versions of one document (i.e., different slideshows for multiple units in the course), I selected the document that best represented all available versions of that document. The document selection process allowed me to include the largest variety of documents possible in the final analysis. The final documents selected for analysis as distributed by classroom are listed in Table 1 on page 48.

Final document selection rationale. I used four themes of questions to narrow documents from a classroom for use in the analysis. I aimed to select documents with the largest variety of responses to a number of questions concerning variety of document type, method of document access, document design, and intent for the students. This selection process helped me to assess the most comprehensive collection of documents for effectiveness in the classroom.

Variety of document type. Selecting documents that include a variety of types and uses can help show patterns and needs across multiple areas. I selected documents so that the analysis could include the largest variety of document types.

- *Are a variety of document types included across each classroom analysis, or are the selected documents designed and used similarly?* Analyzing a variety of documents across a single classroom shows patterns across a teacher's document use choices. Analyzing a group of similarly-used documents (i.e., analyzing only a quiz, chapter test, final exam, and other assessments)

provides less qualitative benefit to the study. A teacher creating documents for their own classroom might tailor the design to meet specific classroom needs.

- *Does the classroom include both user-created documents and publisher-provided documents whenever possible?* Including publisher-provided documents in the study allows me to analyze if a teacher's decision to use a particular publisher works well for the classroom. Using documents from multiple publishers within one classroom might create a lack of consistency across the entire classroom of documents.

Method of document access. How students access documents will impact their own interpretation of each document. Some documents may work better as a digital distribution instead of a paper distribution, and vice versa.

- *Would a student typically access the document on their personal device, or do they receive it as a paper document?* Students interact with paper documents and digital documents very differently, and may prefer one type over the other. Including both types of documents in the analysis allows me to look for patterns between document types.
- *If a student normally accesses the document on a device, what distribution methods does the teacher typically use?* A teacher might use different methods of accessibility (i.e., documents distributed via Google Drive, student email, and/or a class website) across a classroom of documents. A teacher that relies on one distribution method might yield different results from a design than a teacher who distributes documents across multiple platforms.

Document design. A primary goal of this study is to provide recommendations for document design in the classroom. As a result, documents with evident need of a redesign of elements received stronger consideration for final analysis.

- *Could the document benefit from a clear redesign of elements?* If a student encounters a document and immediately has trouble reading and understanding it, the document likely requires analysis for use of design conventions. The need for a redesign of elements may show in some documents more than others.
- *Does the document already follow some information design conventions?* Many publisher-provided documents might follow recommended information design conventions, but some might not. For user-created documents, many teachers are unaware of such design conventions, resulting in poorly designed documents that end up affecting student achievement. These conventions align with those found in the Review of Literature research on page 8.

Intent for the students. Document needs will change based on how students will use the document in the classroom. Teachers need to remain aware of this intent when selecting or creating documents for their classroom.

- *Do students use the document as a reference, or do they return the document to the teacher?* A document intended for a student to fill out and return will differ from one simply used as a reference. Documents should follow certain design conventions, and a lack of these conventions can confuse students. Examining both types of documents allows for an analysis of conventional element use in those documents that require a resubmission to the teacher.

While the Dean of Faculty and I made every effort to collect documents from a variety of course genres and grade levels, ultimately the final selections were limited to those teachers who volunteered to participate. As a result, I could not analyze every genre and grade level offered at the school as part of the study.

Table 1 below provides a summary of all documents used in the study, including a distribution of courses and grade levels.

Table 1
Overview of Classrooms and Documents

Classroom	Course	Grade Levels	Documents
A	AP Physics	11 and 12	Study Guide Chapter Test Short Answers Calculations Quiz Chapter Notes
B	American Literature	11	Textbook Lesson Plan Unit Notes Quiz Short Story Final Exam Review
C	Integrated Science	6 and 7	Chapter Test Slideshow Problem Set Worksheet Scavenger Hunt Lesson Plan
D	Spanish 1	8, 9, and 10	Lesson Plan Video Worksheet Conversation Cards Vocab Slideshow Transparencies Chapter Test

Document Analysis and Data Collection

Document analysis began with the creation of a qualitative instrument, called Educational Document Design and Information Evaluation (EDDIE) forms (see Figure 1 below). I created three EDDIE forms specifically for this study, with unique forms for Lesson Plans, Adopted Textbooks, and Supplemental Documents. EDDIEs for Supplemental Documents provided analysis questions for all documents outside of textbook pages and lesson plans. I created qualitative questions under six themes based on research and information found in the six Review of the Literature sections: Information Design, Textbook Decisions, Implementation of Electronic Textbooks, Technology Use in the Classroom, Cognitive Psychology, and Lesson Planning and Pedagogical Design. Each of the three EDDIE forms included only those questions relevant to the type of document being analyzed (i.e., the EDDIE for Supplemental Documents does not include questions related to lesson plans). Appendix C on page 139 includes full versions of all three EDDIE forms.

Educational Document Design and Information Evaluation (EDDIE) for Supplemental Documents	
Classroom: _____ Document: _____	
Information Design	
1. Is hierarchy used to show content importance?	
2. Is style—size, face, style, color, and shape—used to show relationships with other elements?	
3. Is there any variation in typeface?	
4. Is spacing used to differentiate elements?	
5. Is the document user-created or publisher-provided?	
6. Is there ample space for student answers, if applicable?	
7. Are any visuals provided in the document?	
8. For science and mathematics courses, are any graphics included in the document?	
8a. Are any graphics three-dimensional?	
8b. Are graphics integrated in a way that would make sense to readers?	
Technology Use in the Classroom	
1. Is the document accessed electronically?	
2. How do students typically receive and submit the document?	
3. What type of device is most often used to access the document?	
4. Is <i>Google Apps for Education</i> used?	
Cognitive Psychology	
1. Could the document's length have an effect on the student's mental effort?	
2. Are there any elements of play involved?	
3. Could any external factors affect a student's use of this document?	

Figure 1. Sample (EDDIE) form for Supplemental Documents.

The use of a new EDDIE for each document volunteered by a teacher allowed me to analyze patterns and trends of document design and accessibility among teachers, courses, grade levels, and the entire Brandon Hall School culture. Depending on the types of documents volunteered by teachers, not every classroom used all three EDDIE forms.

Data collection occurred in the form of questions and responses for each document. I then compared documents and teacher notes to the information and research found in the Review of the Literature. Elements that do not follow current trends and recommendations in information design and education were recorded on the EDDIE forms, with additional notes as to what design choices the documents presently follow. Across the four classrooms in the study, I completed a total of 24 EDDIE forms.

Analysis of reading level. The EDDIE form for Adopted Textbooks allows for the analyzation of appropriate writing style. This analysis of reading level involves copying the text into Microsoft Word, and using the program to evaluate the Flesch-Kincaid reading level. While other reading level scales exist, I followed the well-known Flesch-Kincaid scale due to its inclusion in Microsoft Word. The inclusion of this scale in Microsoft Words results in teacher having easy access to the tool. This allows teachers to evaluate the calculated reading levels of their own classroom documents.

The document analysis process through the use of the EDDIE forms relies on a subjective assessment. My professional and educational background in document design, in addition to experience designing documents used in a school environment, provide me with the knowledge I need to accurately analyze documents for effective design, particularly for student readers.

The following Analysis chapter outlines the specific data collected in the document collection process. An examination of resulting patterns follows in the Discussion chapter on page 97, with recommendations for future document design and accessibility in the Recommendations chapter on page 115.

CHAPTER FOUR: ANALYSIS OF DOCUMENTS

This analysis of documents section is limited to a listing of qualitative responses provided on each classroom's EDDIE (Educational Document Design and Information Evaluation) forms, including the EDDIEs for Lesson Plans, Adopted Textbooks, and Supplemental Documents. The Discussion chapter on page 97 examines the patterns found in the document analysis as compared to information in the literature review. Following this discussion, the Recommendations and Conclusions chapter on page 115 lists overall recommendations to teachers at Brandon Hall School based on the found patterns of document design and distribution.

For this analysis, key terms are defined as follows:

- “Hierarchy” refers to the use of size increments and style changes in text to show element importance.
- “Style” refers to typographic choices (such as changes in size, face, color, and shape) that show emphasis, importance, and relationships between elements.
- “Spacing” refers to the use of white space in a document to show relationships between elements.
- “User-created” means the teacher created the document on a word processing program such as Microsoft Word or Google Docs.
- “Graphics” refer to visuals meant for “storing, understanding, and communicating information” and can include such items as “graphs, maps, number lines, and flowcharts,” among others (Lowrie, Diezmann, & Logan, 2011). Similarly, a “visual” is the incorporation of an image or picture within a document's design to accompany presented information.

Classroom A

Classroom A is an 11th and 12th grade Advanced Placement (AP) Physics class. The teacher provided a study guide, chapter test, short answers, calculations, quiz, and chapter notes for use in the analysis. Analysis of this classroom required only EDDIE forms for Supplemental Documents. Table 2 below lists the individual documents, EDDIE form used, creation method (either user-created or publisher-provided), and document type (paper, digital, or both).

Table 2
Overview of Documents in Classroom A

Document	EDDIE Form Used	Creation Method	Document Type
Study Guide	Supplemental Documents	User-Created	Digital
Chapter Test	Supplemental Documents	User-Created	Paper
Short Answers	Supplemental Documents	User-Created	Digital Paper
Calculations	Supplemental Documents	User-Created	Digital Paper
Quiz	Supplemental Documents	User-Created	Paper
Chapter Notes	Supplemental Documents	User-Created	Digital

Document 1: Study Guide. Figure 2 below shows a sample page of the Study Guide used in Classroom A. Analysis of this document required the EDDIE form for Supplemental Documents.

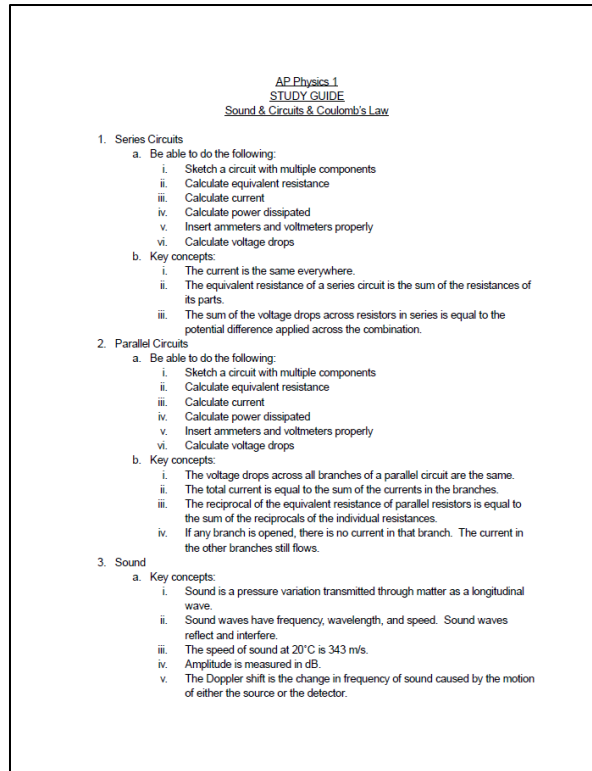

Figure 2. Sample page of the Study Guide used in Classroom A.

Information design. The Study Guide was user-created in Google Docs using a sans serif text. The 8.5-inch by 11-inch, letter size document uses standard 1-inch margins. In terms of hierarchy, the document follows an outline format (incorporating indented bullet points under broader topics); however, differences in text size to show importance do not exist. Stylistic elements do not change throughout the body of the document. The document title uses an underline and change in alignment as the only style differences. There is no spacing between elements of the outline, and the teacher did not include any graphics in this document.

Technology use in the classroom. Students access the document electronically. They receive the document through a shared Google Drive document, and do not resubmit the document to the teacher. The teacher uses *Google Apps for Education*,

including Google Docs for the document creation and Google Drive for document sharing. Students will most often access the document on their personal laptop.

Cognitive psychology. Most likely, the document length will not have an effect on a student's required level of mental effort. The two-page document uses many bullets listed as sentence fragments. In regards to external factors that may affect a student's use of the document, the stress of studying for an AP-level examination might affect a student's understanding and interpretation. The document includes no elements of play.

Document 2: Chapter Test. Figure 3 below shows a sample page of the Chapter Test used in Classroom A. Analysis of this document required the EDDIE form for Supplemental Documents.

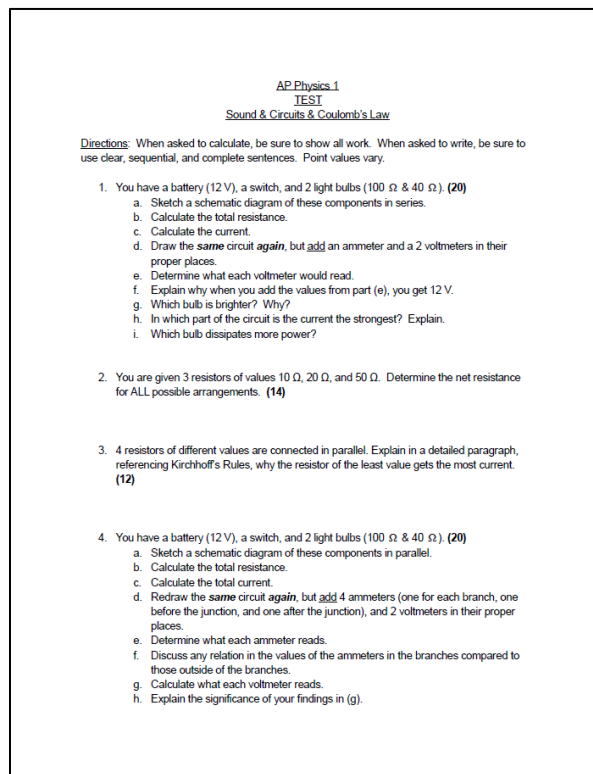

Figure 3. Sample page of the Chapter Test used in Classroom A.

Information design. The Chapter Test was user-created in Google Docs using a sans serif text. The 8.5-inch by 11-inch, letter size document uses standard 1-inch

margins. The document does not use hierarchy to show element importance. Instead, the document uses typeface emphasis only to show values and keywords in each question. The document uses spacing effectively to show students the different questions they must respond to. However, students write their responses on a separate piece of paper, and do not use this space for their responses. The document includes one graphic in the final calculation problem, as shown in Figure 4 below. This two-dimensional graphic immediately follows the question referencing it, helping to ensure that the graphic is integrated in a way that would make sense to the readers.

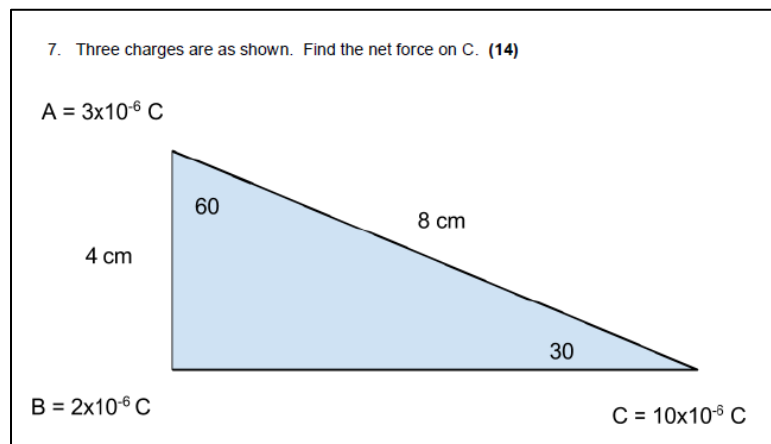

Figure 4. Graphic used in the Chapter Test document.

Technology use in the classroom. Students receive a paper version of the test to help them prepare for AP examination conditions, and submit their responses on a separate piece of paper. The teacher uses *Google Apps for Education*, including Google Docs for the document creation and Google Drive for document storage prior to printing.

Cognitive psychology. Most likely, the document length will not have an effect on a student's required level of mental effort. The two-page document includes questions where the level of intensity may affect required mental effort. Regarding external factors,

the stress of studying for an AP-level examination might affect a student's understanding and assessment. The document includes no elements of play.

Document 3: Short Answers. Figure 5 below shows a sample page of the Short Answers document used in Classroom A. Analysis of this document required the EDDIE form for Supplemental Documents.

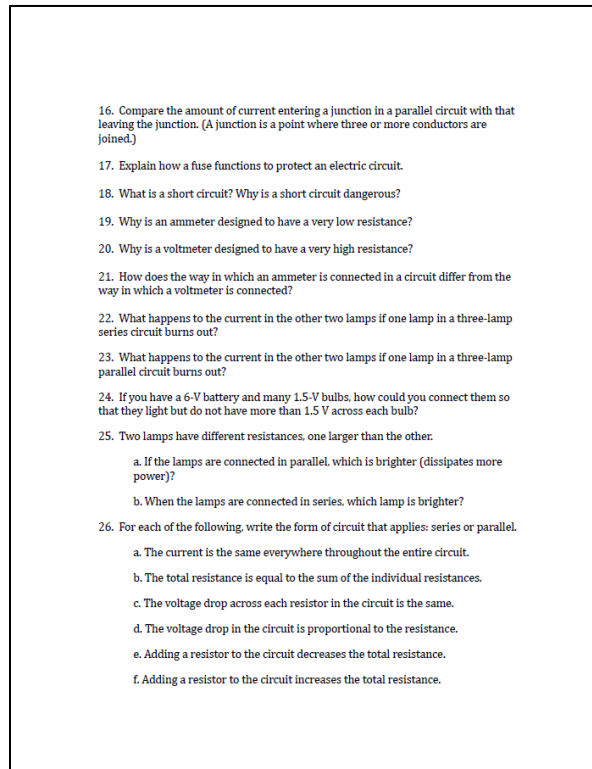

Figure 5. Sample page of Short Answers document used in Classroom A.

Information design. The Short Answers document was user-created in Google Docs using a serif text. The 8.5-inch by 11-inch, letter size documents uses standard 1-inch margins. In terms of hierarchy, the document follows an outline format (incorporating indented bullet points under question instructions); however, differences in text size to show importance do not exist. The document title uses an underline and emphasis, but stylistic elements do not change throughout the remainder of the document.

There is consistent spacing between each question and sub-question, and the teacher did not include any graphics in this document.

Technology use in the classroom. Students access the document electronically. They most often receive the document through a shared Google Drive document. Students typically respond on the digital document itself through Google Docs, unless the assignment requires a drawing on a separate sheet of paper. The teacher noted that students often submit a mixture of digital and handwritten responses. The teacher uses *Google Apps for Education*, including Google Docs for the document creation and Google Drive for document sharing. Students will most often access the document on their personal laptop.

Cognitive psychology. The document's length may have an effect on a student's required level mental effort. The document includes 27 questions, with some containing multiple sub-questions requiring a number of responses. Regarding external factors, the stress of studying for an AP-level examination might affect a student's understanding and completion. The document includes no elements of play.

Document 4: Calculations. Figure 6 below shows a sample page of the Calculations document used in Classroom A. Analysis for this document required the EDDIE form for Supplemental Documents.

Information design. The Calculations document was user-created in Google Docs using a serif text. The 8.5-inch by 11-inch, letter size document uses standard 1-inch margins. In terms of hierarchy, the document follows an outline format (incorporating indented bullet points under broader topics); however, differences in text size to show

13. A series circuit has two voltage drops: 5.50 V and 6.90 V. What is the supply voltage?

14. A parallel circuit has two branch currents: 3.45 A and 1.00 A. What is the current in the energy source?

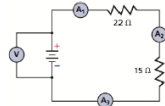

15. Ammeter 1 in reads 0.20 A.

- What should ammeter 2 indicate?
- What should ammeter 3 indicate?
- What is the total resistance of the circuit?
- What is the battery voltage?
- How much power is delivered to the 22 Ohm resistor?
- How much power is supplied by the battery?



16. Refer to the figure above.

- What should the ammeter read?
- What should voltmeter 1 read?
- What should voltmeter 2 read?

Figure 6. Sample page of the Calculations document used in Classroom A.

importance do not exist. The document title uses an underline and emphasis, but stylistic elements do not change throughout the remainder of the document. There is consistent spacing between each question and sub-question.

Figure 6 above shows two of the many circuit drawings included in the document. The two-dimensional graphics immediately follow the questions referencing them, helping to create an effective integration of graphics in a way that would make sense to the reader.

Technology use in the classroom. Students access the document electronically. They most often receive the document through a shared Google Drive document. Students submit their responses on a separate, handwritten document. The teacher uses *Google Apps for Education*, including Google Docs for the document creation and

Google Drive for document sharing. Students will most often access the document on their personal laptop.

Cognitive psychology. The document's length may have an effect on a student's required level mental effort. The document includes 21 questions. Some of these questions also contain multiple sub-questions, which require the student to complete a number of additional calculations. Regarding external factors, the stress of completing AP-level questions might affect an individual student's understanding and completion. The document includes no elements of play.

Document 5: Quiz. Figure 7 below shows a sample page of the Quiz used in Classroom A. Analysis of this document required use of the EDDIE form for Supplemental Documents.

Name _____
Date _____

Chapter 19
Quiz
DC Circuits

1. Ammeter 1 in reads 0.20 A.

- What should ammeter 2 indicate?
- What should ammeter 3 indicate?
- What is the total resistance of the circuit?
- What is the battery voltage?
- How much power is delivered to the 22 Ohm resistor?
- How much power is supplied by the battery?

2. A 16.0 Ohm and a 20.0 Ohm resistor are connected in parallel. A difference in potential of 40.0 V is applied to the combination.

- Compute the equivalent resistance of the parallel circuit.
- What is the total current in the circuit?
- What is the current in the 16.0 Ohm resistor?

3. Suppose you have a 200-ohm, an 80-ohm, and a 300-ohm resistor. What is (a) the maximum, and (b) the minimum resistance you could obtain by combining these?

Figure 7. Sample page of the Quiz used in Classroom A.

Information design. The Quiz was user-created in Google Docs using a serif text. The 8.5-inch by 11-inch, letter size document uses standard 1-inch margins. In terms of hierarchy, the document follows an outline format (incorporating indented bullet points under broader topics); however, differences in text size to show importance do not exist. The document title uses an underline and emphasis, but stylistic elements do not change throughout the remainder of the document. While there is consistent spacing between each question and sub-question, students are not provided with ample room on the printed page to write in their responses.

Figure 6 above shows the single circuit drawing included in the document. This two-dimensional graphic immediately follows the question referencing it, helping to create an effective integration of graphics in a way that would make sense to the reader.

Technology use in the classroom. Students receive a paper version of the quiz to help them prepare for AP examination conditions, and submit their responses on the same piece of paper. The teacher uses *Google Apps for Education*, including Google Docs for the document creation and Google Drive for document storage prior to printing.

Cognitive psychology. Most likely, the document length will not have an effect on a student's required level of mental effort. The quiz includes very few questions. Regarding external factors, the stress of studying for an AP-level examination might affect an individual student's understanding and assessment. The document includes no elements of play.

Document 6: Chapter Notes. Figure 8 below shows a sample page of the Chapter Notes used in Classroom A. Analysis of this document required use of the EDDIE form for Supplemental Documents.

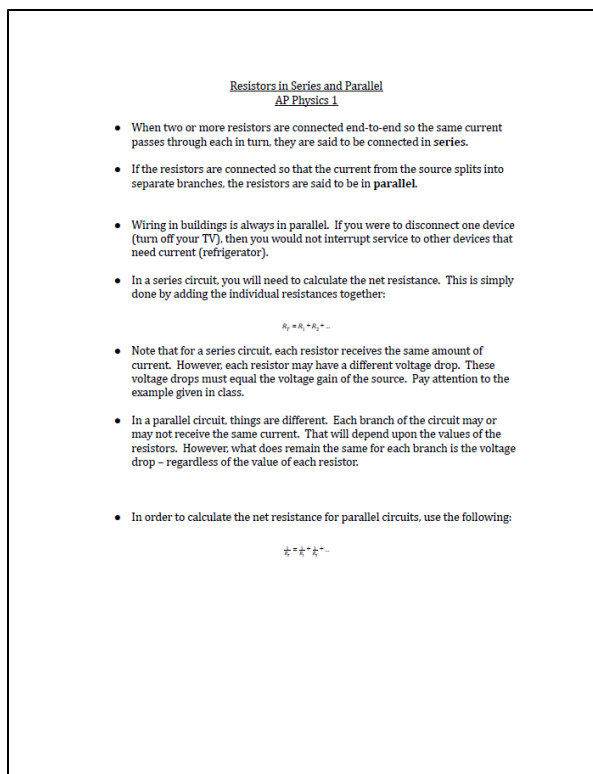

Figure 8. Sample page of the Chapter Notes document used in Classroom A.

Information design. The Chapter Notes document was user-created in Google Docs using a serif text. The 8.5-inch by 11-inch, letter size document uses standard 1-inch margins. In terms of hierarchy, important equations appear much smaller than the other information on the page, opposite to how the use of hierarchy should be employed on this document. Very few stylistic changes occur throughout the body of the document. The title of the document appears underlined and centered, and few keywords have emphasis. There is ample spacing between the different bullet points in the document. The teacher did not include any graphics in this document.

Technology use in the classroom. Students access the document electronically. The teacher noted that students can download the document as a PDF from the class website. Students do not resubmit the document. The teacher uses *Google Apps for*

Education by creating the document in Google Docs. Students will most often access the document on their personal laptop.

Cognitive psychology. Most likely, the document length will not have an effect on a student's required level of mental effort. The page-long requires no assessment on the part of the student. Regarding external factors, the stress of understanding AP-level material might affect a student's understanding and retention prior to an assessment. The document includes no elements of play.

Classroom B

Classroom B is an 11th grade American Literature class. The teacher provided a textbook sample, lesson plan, unit notes, quiz, short story, and final exam review for use in the analysis. The analysis of this classroom required the use of all three EDDIE forms (Lesson Plans, Adopted Textbooks, and Supplemental Documents). Table 3 below lists the individual documents, EDDIE form used, creation method (either user-created or publisher-provided), and document type (paper, digital, or both).

Document 1: Textbook. Figure 9 below shows a sample page of the Textbook used in Classroom B. This document analysis required the use of the EDDIE form for Adopted Textbooks.

Textbook decisions. The teacher incorporated a web-accessed textbook into the curriculum, published through Holt McDougal. Based on the Flesch-Kincaid Reading Level scale, the writing style seems appropriate for the grade level of students accessing the textbook. The reading level for the content page above in Figure 9 measured at an 8.5,

Table 3
Overview of Documents in Classroom B

Document	EDDIE Form Used	Creation Method	Document Type
Textbook	Adopted Textbooks	Publisher-Provided	Digital
Lesson Plan	Lesson Plans	User-Created	Digital
Unit Notes	Supplemental Documents	User-Created	Digital
Quiz	Supplemental Documents	User-Created	Digital
Short Story	Supplemental Documents	User-Created	Digital
Final Exam Review	Supplemental Documents	User-Created	Digital

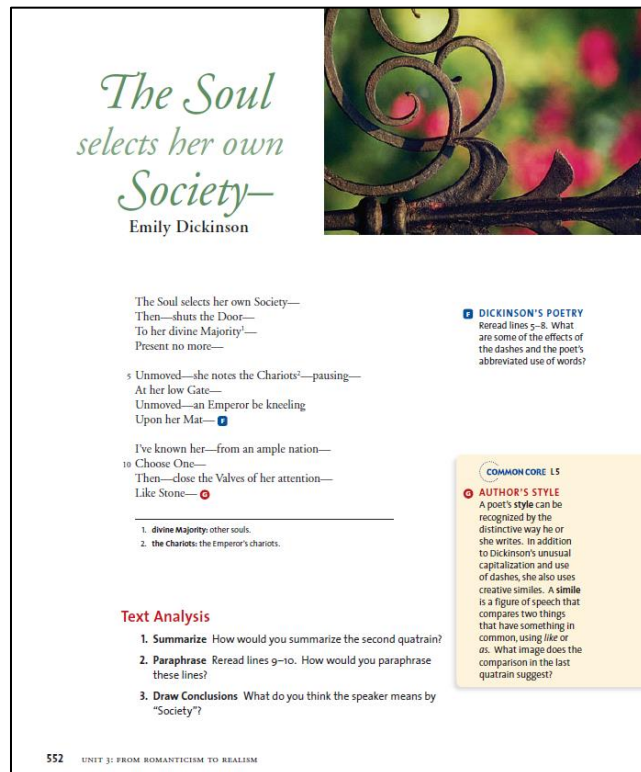

Figure 9. Sample page from the electronic textbook used in Classroom B.

whereas the reading level for the text-heavy introduction for the same chapter (shown in Figure 10 below) measure at a 10.2. For a classroom where the majority of students are in grade 10, these reading levels are appropriate for student comprehension.

COMMON CORE
 RL.1 Cite evidence to support analysis of what the text says explicitly as well as inferences drawn from the text. RL.2 Determine two or more themes or central ideas of a text. RL.4 Determine the meaning of words and phrases used in the text, including figurative meanings; analyze the impact of specific word choices on meaning and tone, including language that is particularly fresh, engaging, or beautiful. RL.5 Analyze how an author's choices concerning how to structure specific parts of a text contribute to its overall structure and meaning as well as its aesthetic impact.

DID YOU KNOW?
 Emily Dickinson ...
 • sometimes signed her letters "Uncle Emily,"
 • dressed only in white in the last 16 years of her life.
 • had eye problems and feared that she might go blind.

Meet the Author
Emily Dickinson 1830–1886
 Emily Dickinson rarely ventured beyond the confines of her family home in Amherst, Massachusetts, but her restless mind and creativity knew no such boundaries. In her bedroom overlooking the village graveyard, Dickinson meditated on life and death and wrote about these subjects with startling originality. Today she and Walt Whitman are considered the greatest American poets of the 19th century.

Family Ties Dickinson was born in 1830 into a well-to-do family, which would become the center of her existence. She stood in awe of her father, a stern, imposing man committed to Puritan ideals, and felt estranged from her mother, who "did not," Dickinson once commented in a letter, "care for thought." However, she had a close relationship with her older brother, Austin, and her younger sister, Vinnie.

In 1847, Dickinson left home to attend Mount Holyoke Female Seminary in nearby South Hadley, but she left after just one year. She missed her family, but she also resented the intense pressure she felt there to join the church. All her life, Dickinson felt torn between her own convictions and the religious beliefs of those around her. This conflict is reflected in many of her poems.

A Writer's Life In the 1850s, Dickinson began to devote herself to poetry. Late at night, she wrote by candlelight. During the day, she jotted down her thoughts between household chores. Inspired by her own observations and experiences, Dickinson composed a remarkable number of profound, gemlike poems.

Perhaps because of this newfound focus on her writing, Dickinson gradually withdrew from the world. However, she did not become a total recluse. She entertained occasional visitors in her home and maintained contact with friends and family by means of a lively correspondence.

Poetic Legacy Early in 1886, Dickinson wrote a letter to her cousins that simply read "Called back." She seemed to have realized that she was dying. Following her death, her sister Vinnie discovered a box full of Dickinson's poems bound into neat booklets. As a result of Vinnie's perseverance, the first volume of Dickinson's poetry appeared four years after the poet's death. Her poems—1,775 in all—finally revealed to the world the passionate, witty woman who never flinched from the truth.

Authay Online
 Go to thinkcentral.com. KEYWORD: HMLTI-546A

546

Figure 10. Chapter Introduction page used in the Classroom B textbook.

Implementation of electronic textbooks. Students access the electronic textbook online through a publisher-provided textbook website portal, located at *my.hrw.com*. Each student has a unique login to access the textbook portal, as well as other textbooks from the same publisher that other teachers may have assigned. Students also have the option to download individual textbook sections in PDF form should the need arise.

The textbook is primarily static, and lacks much interactive ability. Students can access some multimedia features through the textbook sidebar, including a note-taking program, references to video clips on a separate DVD-ROM, PowerPoint summaries, and video trailers. Some of the textbook pages provide links to media tools at a different

URL; however, these pages are not hyperlinked through the webpage, and instead students must input the URL manually to view the recommended pages.

Technology use in the classroom. Students will most often access the textbook electronically on their personal laptop. In the case of an Internet outage, the teacher has PDF downloads of the textbook saved to Google Drive to provide to students when needed. This storage on Google Drive is the only way the teacher uses *Google Apps for Education* in regards to the textbook.

Information design. The Textbook sample page shown in Figure 9 is a publisher-provided document, published by Holt McDougal. The size of the document varies based on the size of the screen used to access the digital pages. Literary text is in serif text, whereas all supplemental material is in sans serif text.

In terms of hierarchy, important elements and headings appear larger in size than remaining text, and vary in color. The document designers use elements of style throughout the textbook pages, including changes in color, size, emphasis, italics, highlighting, and labeling to show relationships between elements. The use of white space seems particularly effective in this document, clearly differentiating the different sections on the page. The document includes one visual, in the form of a picture somewhat related to the literary content.

Cognitive psychology. Regarding external factors, Internet access can affect a student's use of the textbook. A lack of Internet access would likely prove frustrating to a student attempting to access the textbook pages for assignments. The two sample pages in Figures 9 and 10 above include no elements of play. However, other pages in the textbook not included in this analysis may contain such elements.

Document 2: Lesson Plan. Figure 11 below shows a sample page of the Lesson Plan used in Classroom B. The analysis of this document required use of the EDDIE form for Lesson Plans.

November 2-6, 2015 (11)		
American Literature		Literary
Genres		
Mon	Students will be working on creating / editing movie projects using iMovie. Please allow the students to work with each other on the creation of projects / use of iMovie; however, the projects are individual in nature. HW- Continue working on iMovie projects. They will be due on Wednesday.	Students will be working on creating / editing movie projects using iMovie. Please allow the students to work with each other on the creation of projects / use of iMovie; however, the projects are individual in nature. HW- Continue working on iMovie projects. They will be due on Wednesday.
Tue	Continue working on iMovie project. All students should be well into the editing phase of the project and should be able to complete and add to Google Site tomorrow. Students need to consult rubric before completing. HW- Complete iMovie project and upload to either Google Drive or YouTube.	Continue working on iMovie project. All students should be well into the editing phase of the project and should be able to complete and add to Google Site tomorrow. Students need to consult rubric before completing. HW- Complete iMovie project and upload to either Google Drive or YouTube.
Wed	Put iMovie project onto Google Site. Review material about Brooding Romantics. Begin reading and taking notes on "The Masque of the Red Death" (446 - 452). Focus on the use of symbolism in the story. HW- Complete "The Masque of the Red Death" (446 - 452). Take notes on symbolism to turn in. Prepare for quiz tomorrow on the reading.	Put iMovie project onto Google Site. Begin working on "A Voice" (388-399) together. Work on taking notes on the poem and what we should be looking for as readers of poetry. Discuss the purpose of the poem and what can / should be written about it after reading it. HW- Continue reading "To Kill A Mockingbird" and prepare for test #2 on Friday. You will need to put together a review sheet for the test that can be used to help complete the test.
Thur	Quiz on "The Masque of the Red Death". Take notes on the use of symbols / imagery / irony. Discuss the use of Romantic details and how they differ from the Romantics / Transcendentalists. HW- Complete the second essay for Huck Finn.	Discuss yesterday's lesson on poetry. Review what needs to be done when reading and taking notes on a poem. Split the class into groups of two and have them read the poem "My Father's Song" (290). Each group must put together a set of notes on a Google Doc and be prepared to discuss the poem tomorrow after the test.

Figure 11. Sample Lesson Plan page used in Classroom B.

Lesson planning and pedagogical design. The teacher of Classroom B provided a lesson plan for analysis, which consists of separate columns for each course. Each row on the lesson plan lists a single day's classwork and homework assignments.

The provided plans do not include the "why" of the lesson, and instead only list assignments and tasks. Each class period lists two to three objectives, a number within the acceptable range of objectives for student mental effort. The given lesson plan does not address Universal Design for Learning (UDL). However, an iMovie project described during the given lesson plan week may address Problem-Based Learning (PBL).

Information design. The Lesson Plan document was user-created in Google Docs using a serif text. The 8.5-inch by 11-inch, letter size document uses standard 1-inch margins. The lesson plan uses spacing effectively to help differentiate elements. The plan

shows clear divisions between subjects, days, and classwork versus homework. Few stylistic changes exist, with only emphasis used to list homework assignments. Size does not show hierarchy; instead, the document is organized chronologically.

Technology use in the classroom. The lesson plan uses *Google Apps for Education*, through creation in Google Docs and storage on Google Drive. The teacher will most often access the document on their personal laptop and/or iPad, depending on needs and availability at the time.

Document 3: Unit Notes. Figure 12 below shows a sample page of the Unit Notes used in Classroom B. The analysis for this document required use of the EDDIE form for Supplemental Documents.

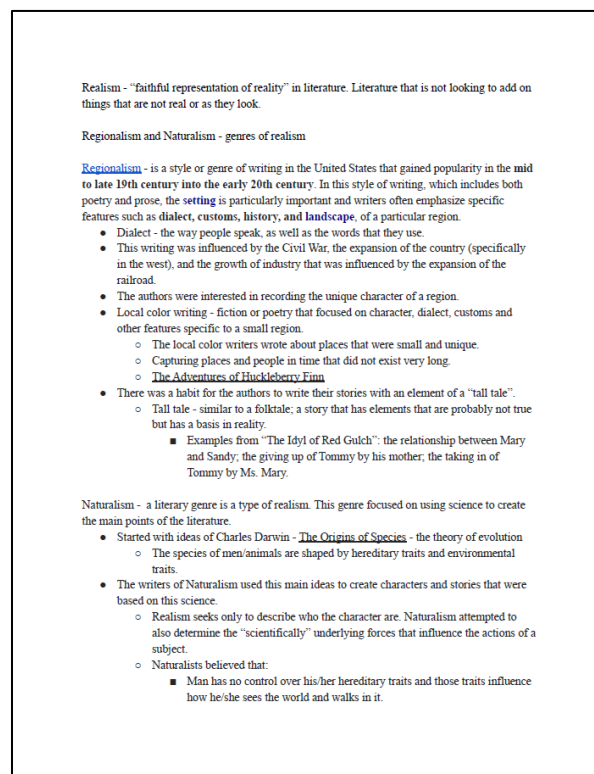

Figure 12. Sample page of Unit Notes document used in Classroom B.

Information design. The Unit Notes document was user-created in Google Docs using a serif text. The 8.5-inch by 11-inch, letter size document uses standard 1-inch

margins. In terms of hierarchy, the document follows an outline format (incorporating indented bullet points under broader topics); however, differences in text size to show importance do not exist. Some elements of style are applied, including underlining, emphasis, and occasional color to show important topics. Spacing differentiates sections of the outline, and seems well-used throughout the document. The teacher did not include any graphics in this document.

Technology use in the classroom. Students access the document electronically. They most often receive the document through a shared Google Drive document. Students do not need to resubmit the document. The teacher uses *Google Apps for Education*, including Google Docs for the document creation and Google Drive for document sharing. Students will most often access the document on their personal laptop.

Cognitive psychology. Most likely, the document length will not have an effect on the student's mental effort. The three-page documents uses an outline format and short sentences to help limit the level of mental effort required to comprehend the document. Few external factors that will affect a student's use of the document. The document includes no elements of play.

Document 4: Quiz. Figure 13 below shows a sample view of the Quiz used in Classroom B. Analysis of this document required use of the EDDIE form for Supplemental Documents.

Information design. The Quiz was user-created through Google Forms using the default text settings. In terms of hierarchy, all questions appear in the same size text, showing that all questions have the same level of importance. Type style does not change throughout the body of the document. Spacing appears consistent between each question,

A screenshot of a Google Form titled "Quiz - The Law of Life". The form is set against a background image of a snowy mountain landscape. It contains five required questions, each with a "Your answer" text field below it. The questions are: "Name: *", "What is the setting of the story? *", "Why is the narrator (Old Koskoosh) being 'left behind'? *", "Explain how females are treated in this culture. *", and "What did Koskoosh and Zing-ha see as youths that Koskoosh thinks about as he is waiting to die? *". The final question is "How did Koskoosh die? *". At the bottom, there is a blue "SUBMIT" button, a green progress bar showing 100% completion, and a small text note: "Never submit passwords through Google Forms."

Figure 13. Screenshot of the Quiz form used in Classroom B.

and Google Forms answer fields expand to allow student responses. The quiz includes one visual, shown at the top of the screenshot in Figure 12 above. This header photo visual is unrelated the quiz context, and acts as an ambient image.

Technology use in the classroom. Students access the document electronically, and receive and submit the quiz through a shared Google Form. The teacher uses *Google Apps for Education*, including Google Forms for the document creation and Google Sheets for the teacher to view the student responses.

Cognitive psychology. Most likely, the document length will not have an effect on a student's required level of mental effort, as the quiz includes only five questions. In regards to external factors that may affect a student's use of the document, the ability to access the quiz electronically may allow students to have access to unauthorized assistance during the assessment. The document includes no elements of play.

Document 5: Short Story. Figure 14 below shows a sample page of the Short Story used in Classroom B. This analysis required use of the EDDIE form for Supplemental Documents.

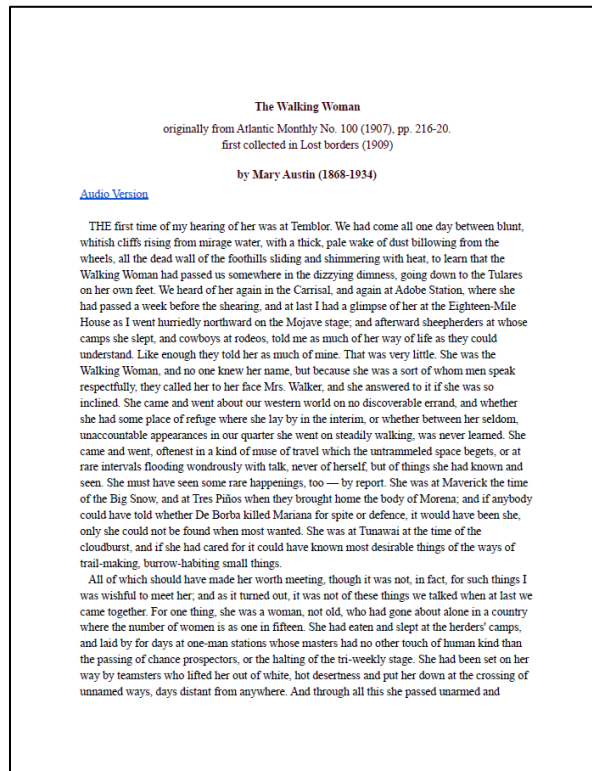

Figure 14. Sample page of Short Story document used in Classroom B.

Information design. The Short Story was user-created in Google Docs using a serif text. The 8.5-inch by 11-inch, letter size document uses standard 1-inch margins. The document does not use size to show hierarchy and importance. Few stylistic changes occur in the document, but it does include a story introduction using color, centered text, and some emphasis. The document exhibits poor use of spacing; there is no spacing between paragraphs, and each paragraph begins with minimal indentation. The teacher did not include any visuals in this document.

Technology use in the classroom. Students access the document electronically. They most often receive the document through a shared Google Drive document.

Students do not resubmit the document. The teacher uses *Google Apps for Education*, including Google Docs for the document creation and Google Drive for document sharing. Students will most often access the document on their personal laptop.

Cognitive psychology. For this document, document length could have an effect on a student's required level of mental effort. The document is long with minimal spacing, resulting in a visual "wall of text" that may prove difficult for a student to comprehend. Regarding external factors, an ability to focus mixed with the document's length can affect a student's interaction with the document. The document includes no elements of play.

Document 6: Final Exam Review. Figure 15 below shows a sample page of the Final Exam Review used in Classroom B. Analysis of this document required the EDDIE form for Supplemental Documents.

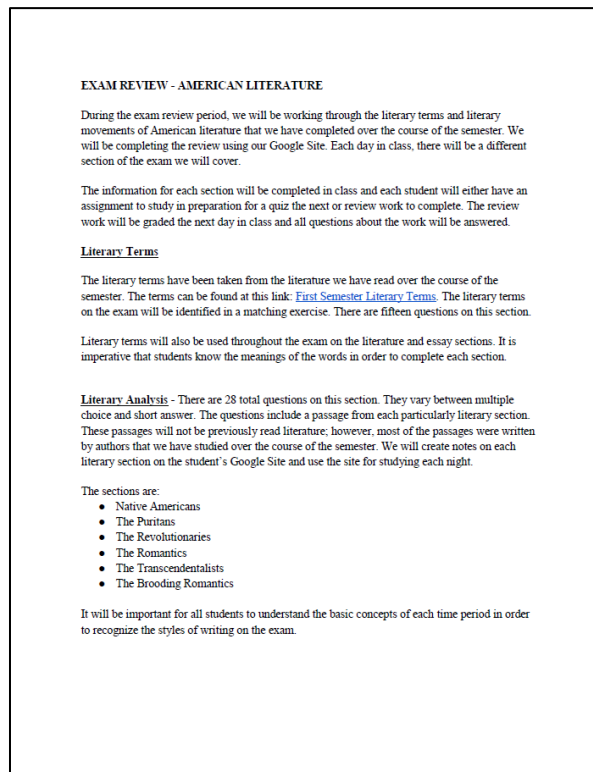

Figure 15. Sample page of the Final Exam Review in Classroom B.

Information design. The Final Exam Review was user-created in Google Docs using a serif text. The document 8.5-inch by 11-inch, letter size document uses standard 1-inch margins. While size does not show hierarchy, the title's importance is shown through the use of capital letters. The document includes some elements of style, including underlining and emphasis to show new elements, and color to show a hyperlink. Spacing is used well throughout the document to differentiate sections of the outline, although proximities between headings and related text vary within the document. The teacher did not include any visuals in this document.

Technology use in the classroom. Students access the document electronically. They most often receive the document through a shared Google Drive document, and students do not resubmit the document. The teacher uses *Google Apps for Education*, including Google Docs for the document creation and Google Drive for document sharing. Students will most often access the document on their personal laptop.

Cognitive psychology. Most likely, the document length will not have an effect on a student's required level of mental effort. Although the comprehensive document covers a large amount of information from the semester, the document covers just over a page. Regarding external factors, the stress of an upcoming final exam may affect a student's interpretation and understanding. The document includes no elements of play.

Classroom C

Classroom C is a 6th and 7th grade Integrated Science class. The teacher provided a chapter test, slideshow, problem set, worksheet, scavenger hunt, and lesson plan for use in the analysis. Analysis of this classroom required EDDIE forms for Supplemental

Documents and Lesson Plans. Table 4 below lists the individual documents, EDDIE form used, creation method (either user-created or publisher-provided), and document type (paper, digital, or both).

Table 4
Overview of Documents in Classroom C

Document	EDDIE Form Used	Creation Method	Document Type
Chapter Test	Supplemental Documents	User-Created	Paper
Slideshow	Supplemental Documents	User-Created	Digital
Problem Set	Supplemental Documents	User-Created	Digital
Worksheet	Supplemental Documents	Publisher-Provided	Paper
Scavenger Hunt	Supplemental Documents	User-Created	Paper
Lesson Plan	Lesson Plans	User-Created	Digital

Document 1: Chapter Test. Figure 16 below shows a sample page of the Chapter Test used in Classroom C. Analysis of this document used the EDDIE form for Supplemental Documents.

Information design. The Chapter Test was user-created in Google Docs using a sans serif text. The 8.5-inch by 11-inch, letter size documents uses standard 1-inch margins. While changes in size do not show hierarchy, the title and instructions are clearly delineated. Some elements of style used include underlining and italics to show instructions. Spacing is used well to show new questions and sections. Students have

Name: _____ Honor Code: _____
 Date: _____
 MS Science

MS Science - Plate Tectonics

Part A - Vocabulary: Use the words below to write the correct word next to each definition

A. Pangaea	D. Rift Valleys	G. Subduction	J. Sea-floor Spreading
B. Slab Pull	E. Asthenosphere	H. Lithosphere	K. Trenches
C. Basal Drag	F. Ridge Push	I. Mid-Ocean Ridge	

____ 1. The earth's outer solid layer.

____ 2. Caused by the mantle pushing up between the cracks between 2 plates.

____ 3. What Sea-Floor Spreading forms.

____ 4. Where subduction occurs.

____ 5. The single large landmass that split into the current continents.

____ 6. Layer of the Earth that flows, causing plates to bump up against each other

____ 7. The process of old crust getting pushed back into the mantle.

____ 8. Magma pushing plates apart as it pushes up through the mid ocean ridge.

____ 9. Where Sea-Floor Spreading occurs.

____ 10. Process of convection currents in the asthenosphere carrying the plates along with them as they move.

____ 11. Rocks pulling the rest of the plate with it as it sinks into the magma during subduction.

Figure 16. Sample page of the Chapter Test used in Classroom C.

ample space to respond to questions, including lines for multiple choice and single-word answers, and many lines of space for short answers.

The teacher included three graphics, used in the short answer section of the test to identify concepts. The three-dimensional graphics use colors and shadows to show depth and important elements, as shown below in Figure 17. For the most part, graphics are integrated in a way that would make sense to the readers. The graphics could benefit from labelling question numbers on the graphic itself to show the relationship between graphic and corresponding answer space.

Technology use in the classroom. Students receive a paper copy of the document, and submit their answers on the same copy. The teacher uses *Google Apps for Education*, including Google Docs for the document creation and Google Drive for document storage.

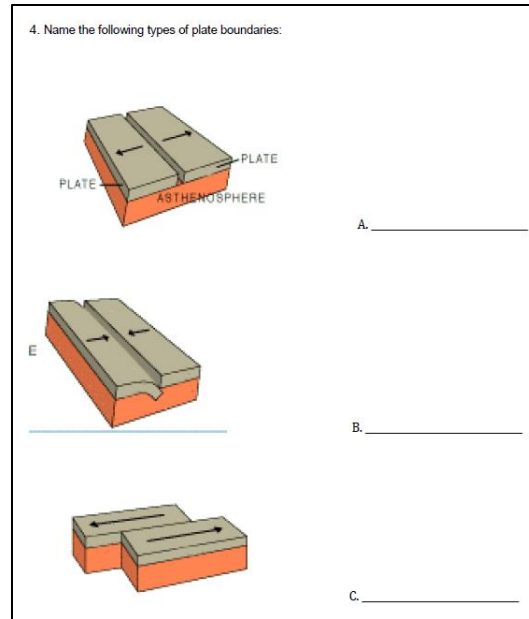

Figure 17. Image of graphics used in Chapter Test document.

Cognitive psychology. Most likely, the document length will not have an effect on a student's required level of mental effort. The test contains 11 multiple choice questions and four short answer questions, and all body text seems appropriate for the student age level. Regarding external factors, the teacher understands that middle school students can be easily distracted when using a computer, and minimizes this by distributing a paper copy instead of electronic. The document includes include an element of play, as a bonus question that encourages students to write a joke about the test content.

Document 2: Slideshow. Figure 18 below shows a sample slide of the Slideshow used in Classroom C. Analysis of this document required an EDDIE form for Supplemental Documents.

Information design. The Slideshow was user-created through Google Slides using the default text settings, using only sans serif text. In terms of hierarchy and style, size and color help show the importance of the headings on each slide. In addition, many slides use an outline format (incorporating indented bullet points under broader topics).

Measurement Systems

Standard System

- ~ AKA: Imperial Systems & English System
- ~ Used by Burma, Liberia, USA (& others for liquids)

Metric System

- ~ Systeme International (SI)
- ~ Used by scientists & most countries
- ~ Based on powers of 10
- ~ Makes conversions easier

Figure 18. Sample slide of Slideshow used in Classroom C.

There is consistent spacing between elements, and sufficient inclusion of white space keeps the document readable. While the document includes no graphics, two colored tables are included.

Technology use in the classroom. Students access the document electronically. They most often receive the document through a shared folder on Google Drive. Students do not resubmit the document. The teacher uses *Google Apps for Education*, including Google Slides for the document creation and Google Drive for document sharing. Students will most often access the document on their personal laptop.

Cognitive psychology. Most likely, the document length will not have an effect on a student's required level of mental effort. Information on slides and the slideshow length are of reasonable length for middle school students. Regarding external factors, middle school students may become distracted by the Internet when accessing the document. The document includes no elements of play.

Document 3: Problem Set. Figure 19 below shows a sample page of the Problem Set document used in Classroom C. Analysis of this document required completion of the EDDIE form for Supplemental Documents.

Complete the following motion/ speed problems:

1. A student rides her bike to school. Her school is 5 miles from her home. She travels at an average speed of 16 miles per hour. How much time does she need for the trip?
2. It takes a plane 5 hours to travel from Philadelphia to San Francisco, which is a 2,500 mile trip. What is the plane's average speed?
3. A rocket can travel at an average speed of 18,000 miles per hour. How far will it travel in 4.5 hours?
4. A man rode on a motorcycle for 2 hours. His average speed was 45 miles per hour. How far did he travel?

Complete the following Chart:

Distance Traveled (D)	Time (t)	Average Speed (v)
27 mi		45 mi/hr
	30 mins	14 ft/min
82 cm	52 s	
8233 ft	2.4 hrs	
	13 hrs	73 mi/hr

Figure 19. Sample page of Problem Set document used in Classroom C.

Information design. The Problem Set document was user-created in Google Docs using a sans serif text. The 8.5-inch by 11-inch, letter size document uses standard 1-inch margins. While changes in size do not show hierarchy, the instructions for students are clearly delineated. The use of elements of style is sparse, only using underlining for all instructions. Ample spacing differentiates elements while keeping instructions in proximity to their corresponding questions. While students have some room for their responses, students resubmit the document electronically and can add space for their responses as needed. The teacher included no graphics in this document.

Technology use in the classroom. Students receive and submit the document electronically. They most often receive the document through a shared folder on Google Drive. The teacher uses *Google Apps for Education*, including Google Docs for the

document creation and shared folders on Google Drive for document sharing and submission. Students will most often access the document on their personal laptop.

Cognitive psychology. Most likely, the document length will not have an effect on a student's required level of mental effort. The document includes eight short answer calculation questions and a fill-in-the-blank table. Regarding external factors, middle school students may become distracted by the Internet when accessing the document. The document includes no elements of play.

Document 4: Worksheet. Figure 20 below shows a sample page of the Worksheet used in Classroom C. The EDDIE form for Supplemental Documents was used for the analysis of this document.

The image shows a worksheet page with the following content:

Name _____ Date _____ Class _____

Key Concept Builder LESSON 1

Minerals

Key Concept What properties can be used to identify minerals?

Directions: On the line before each description, write the letter of the term that matches it correctly. Each term is used only once.

_____ 1. how the surface of a mineral reflects light

_____ 2. Minerals with this property attract steel objects.

_____ 3. how easily a mineral is scratched, or how easily it scratches something else

_____ 4. A mineral breaks along a rough or irregular surface.

_____ 5. This usually can't be used to identify a mineral.

_____ 6. All minerals have this property.

_____ 7. A heavier mineral has this property.

_____ 8. the color of a mineral's powder

_____ 9. A mineral breaks along a smooth, flat surface.

A. cleavage
B. color
C. crystal structure
D. higher density
E. fracture
F. hardness
G. luster
H. magnetism
I. streak

18 Minerals and Rocks

Figure 20. Sample page of the Worksheet used in Classroom C.

Information design. The Worksheet is a publisher-provided document from Glencoe/McGraw-Hill publishers. The document was published on an 8.5-inch by

11-inch letter size paper, with 1-inch and 1.5-inch margins and using a mixture of serif and sans serif text. In terms of hierarchy, a variety of style elements, including changes in typeface, size, italics, and emphasis clearly differentiate different levels of heading. Students have ample space for their short answer responses, whereas other answers are simply circled. The document creator included no graphics in this document.

Technology use in the classroom. Students receive a paper copy of the document, and submit their answers on the same paper copy. The teacher uses *Google Apps for Education*, including Google Drive for document storage.

Cognitive psychology. Most likely, the document length will not have an effect on a student's required level of mental effort. The two-page document only requires students to circle responses or write single-letter responses. Very few external factors might affect a student's use of the document, unless the student is stressed or experiencing a negative mood during the document interaction. The document includes no elements of play.

Document 5: Scavenger Hunt. Figure 21 below shows a sample page of the Scavenger Hunt document used in Classroom C. Analysis of this document required completion of the EDDIE form for Supplemental Documents.

Information design. The Scavenger Hunt was user-created in Google Docs using a serif text. The 8.5-inch by 11-inch, letter size document uses standard 1-inch margins. The document does not apply hierarchy or style in any way, as there are no elements of style applied to any text. Spacing is used well to show the different questions, and students have ample space to respond to the scavenger hunt clues. The teacher included no graphics in the document.

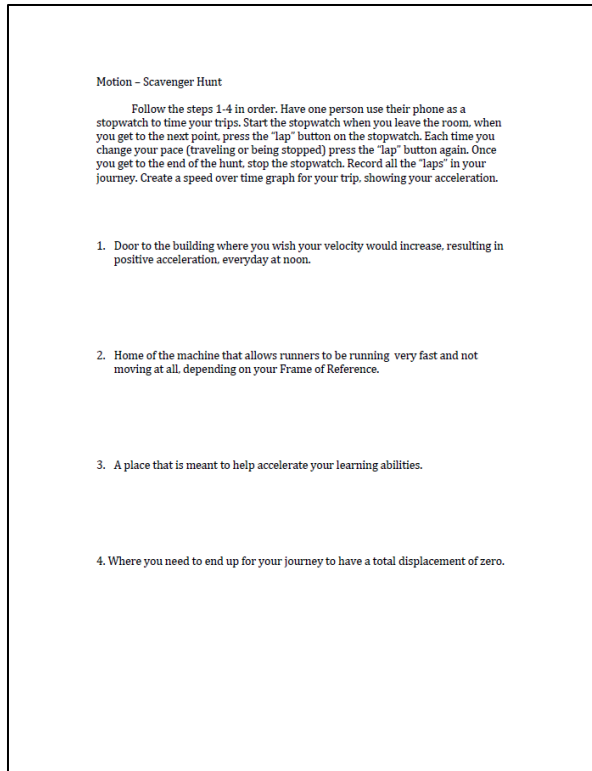

Figure 21. Sample page of the Scavenger Hunt document used in Classroom C.

Technology use in the classroom. Students receive a paper copy of the document, as they must bring the document with them during the scavenger hunt. The teacher uses *Google Apps for Education*, including Google Drive for document creation and Google Drive for document storage.

Cognitive psychology. Most likely, the document length will not have an effect on a student's required level of mental effort. The single-page document requires students to visit only four locations around campus. Regarding external factors, the teamwork element of the assignment may cause stress to the students if personalities and learning styles do not match while completing assignment requirements. The document does include elements of play, in that the assignment requires students to complete activities outside of the classroom and around the school campus.

Document 6: Lesson Plan. Figure 22 below shows a sample page of the Lesson Plan used in Classroom C. Analysis of this document required use of the EDDIE form for Lesson Plans.

6 & 7th Grade - Integrated Science			
Unit/Concept/Time Frame	Brandon Hall Performance Standard	Learning Objectives	Performance Tasks
Unit 1: Basic Science Skills - 2 weeks	<ul style="list-style-type: none"> - Demonstrate an understanding of science basics and the scientific method. - Demonstrate an understanding of measurement and tools. - Demonstrate an understanding of how technology can help us now and in the future. 	<ul style="list-style-type: none"> o Discover the importance of using the scientific method in solving problems. o List the six steps of the scientific method. o Be able to construct activities using each of each steps of the scientific method. o Analyze the role of the different variables in an experiment. o Compare and contrast a hypothesis, a theory, and a scientific law. o Illustrate the difference between observation and data. o Explain the importance of using a common measurement system within science. o Be able to identify the unit and the device used to measure the following: time, distance, force, mass, volume, temperature. o Understand the relationship between robots and technologies. o Explain how robots speed up or extend people's ability to accomplish tasks. o Give example of how nanotechnology may be applied to areas such as the environment and medicine. 	<ul style="list-style-type: none"> - Class discussion - Note taking - Practice problems - Quizzes - Laboratory activities -Data collection from observations -Data analysis -Determining conclusions -Report writing and/or presentation
Unit 2: Space Science - 4 weeks	<ul style="list-style-type: none"> - Demonstrate an understanding of the relationship between the Earth, Sun, and Moon. 	<ul style="list-style-type: none"> o Understand that the Sun provides Earth with heat and light needed to sustain life. o Diagram the phases of the Moon. 	<ul style="list-style-type: none"> - Class discussion - Note taking - Practice problems - Quizzes - Laboratory activities

Figure 22. Sample page of the Lesson Plan used in Classroom C.

Lesson planning and pedagogical design. The lesson plan in Classroom C uses a 4-column format, listing the unit and timeframe, related performance standard, learning objectives, and performance tasks. While the teacher includes the “why” of the lessons by listing the performance standards, the unit-based format does not allow for a listing of objectives per period. Effective use of UDL and PBL cannot be determined by analyzing this lesson plan alone.

Information design. The Lesson Plan document was user-created in Google Docs using a sans serif text. The 8.5-inch by 11-inch, letter size document uses standard 1-inch margins. The use of style and typeface to show relationships between elements is sparse.

Table headers have text emphasis, and the entire document uses sans serif text. The use of spacing helps to separate different performance standards and grouped objectives.

	<p>energy changes from one form to another.</p> <p>~ Demonstrate an understanding of how thermal and light energies are transferred.</p>	<ul style="list-style-type: none"> o Distinguish between acids and bases. o Identify forces acting on an object and the net force. o Be able to identify friction when it is helpful and when it is harmful. o Know how mass and distance impacts the gravitational force between two objects. o Determine how frame of reference is used to describe motion. o Calculate speed, velocity, and acceleration. o State Newton's three laws of motion and give examples of each. o Recognize that work is done when a force moves an object. o Understand how machines help people do work. o Identify and describe six types of simple machines. o Understand how simple machines combine to make compound machines. o Identify ways energy changes from one form to another. o Explain the laws of conservation of mass and of energy. o Experiment with how electricity flows in an electric circuit. o Differentiate between a series circuit and a parallel circuit. o Describe magnetic fields and magnetic domains. o Explain the relationship between electricity and magnetism in an electromagnet. 	
--	--	--	--

Figure 23. Page from Lesson Plan showing unused column space.

The 4-column format on a vertical page proves detrimental to the document use. When one column has a large amount of information, the column stretches the length of a page or more with the other columns left blank (see Figure 23 above). In addition, the limited width of the column only allows for a few words per line, making efficient reading of the document very difficult.

Technology use in the classroom. The document was created electronically on Google Docs and stored on Google Drive, making use of *Google Apps for Education*. The teacher can access the lesson plans on a personal laptop or an iPad, depending on needs and availability at the time.

Classroom D

Classroom D is an 8th, 9th, and 10th grade Spanish 1 class. The teacher provided a lesson plan, video worksheet, conversation cards, vocab slideshow, transparencies, and a review sheet for use in the analysis. Analysis of this classroom required use of the EDDIE forms for Lesson Plans and Supplemental Documents. Table 5 below lists the individual documents, EDDIE form used, creation method (either user-created or publisher-provided), and document type (paper, digital, or both).

Document 1: Lesson Plan. Figure 24 below shows a sample page of the Lesson Plan used in Classroom D. Analysis of this document required use of the EDDIE form for Lesson Plans.

Lesson planning and pedagogical design. Much like in Classroom C's lesson plan in Figures 21 and 22, the lesson plan in Classroom D uses a 4-column format, listing the unit and timeframe, related performance standard, learning objectives, and performance tasks. While the teacher included the "why" of the lessons by listing the performance standards, the unit-based format does not allow for the inclusion of objectives per period. The effective use of UDL and PBL cannot be fully determined by analyzing this lesson plan.

Information design. The Lesson Plan document was user-created in Google Docs using a sans serif text. The 8.5-inch by 11-inch, letter size document uses standard 1-inch margins. The use of style and typeface to show relationships between elements is sparse. Table headers have text emphasis, and the entire document uses sans serif text.

Compared to Classroom C's lesson plan in Figures 21 and 22, Classroom D's lesson plan does not use spacing as effectively to differentiate elements within columns.

Table 5
Overview of Documents in Classroom D

Document	EDDIE Form Used	Creation Method	Document Type
Lesson Plan	Lesson Plans	User-Created	Digital
Video Worksheet	Supplemental Documents	Publisher-Provided	Digital Paper
Conversation Cards	Supplemental Documents	Publisher-Provided	Digital Paper
Vocab Slideshow	Supplemental Documents	User-Created	Digital Paper
Transparencies	Supplemental Documents	Publisher-Provided	Digital Paper
Review Sheet	Supplemental Documents	User-Created	Digital

SPANISH 1 LESSON PLANS:			
Unit/Concept/ Time Frame	Brandon Hall Performance Standard	Learning Objectives	Performance Tasks
Bienvenidos Unit 1 Hola, ¿qué tal? 1.5 Weeks	The student will learn to be able to : 1. Greet people in Spanish, say goodbye. 2. The student will learn to be able to identify themselves and others. 3. The student will learn how to be able to talk about the time of day.	1a. Identify terms for greetings and goodbyes. 1b. Use basic greetings, farewells, and expressions of courtesy. 2a. Identify where one is from. 2b. Identify forms of the verb ser and point out subject pronouns. 2c. Discuss the Spanish alphabet and the name of the letters. 2d. Use formal and informal forms of address. 2e. Identify gender of nouns and definite and indefinite articles. 2f. Identify the numbers 0-30. 2g. Write a telephone/address list in Spanish. 3a. Identify terms for asking and telling time. 3b. Discuss times of the day. 3c. Investigate and reflect on the demographic and	~Intro to technology that will be used in class (Google, textbook, Smartbook, NetClassroom) ~Syllabus and Rubrics (21st Century Skills and Participation) ~Note taking on Grammar Concepts ~Reading Poetry, etc. ~Writing Prompts ~Listening activities in Spanish ~Cultural Perspectives - Dance, Art, etc. ~Games to practice alphabet and number identification ~Greeting and Introductions: Subject Pronouns (I and You) ~Greet and Make introductions ~Identify sociolinguistic conventions of the target

Figure 24. Sample page of Lesson Plan used in Classroom D.

Spacing is only used between elements in the Performance Standards column. Columns containing more information lack this use of spacing to help make the document more readable.

Once again, the 4-column format on a vertical page proves detrimental to the document use. When one column has a large amount of information, the column stretches the length of a page or more with the other columns left blank. In addition, the limited width of the column only allows for a few words per line, making efficient reading of the document particularly difficult.

Technology use in the classroom. The document was created electronically on Google Docs and stored on Google Drive, making use of *Google Apps for Education*. The teacher can access the lesson plans on a personal laptop or an iPad, depending on needs and availability at the time.

Document 2: Video Worksheet. Figure 25 below shows a sample page of the Video Worksheet used in Classroom D. Analysis of this document required use of the EDDIE form for Supplemental Documents.

Information design. The Video Worksheet is a publisher-provided document from McDougal Littell publishers. The 8.5-inch by 11-inch, letter size document was published with approximately 1-inch margins. The document uses a mixture of serif and sans serif text. In terms of hierarchy, a variety of style elements, including changes in typeface, size, and emphasis, help to clearly differentiate levels of heading. Students have ample room to respond to questions, with short answer sections allowing for two lines of response. The document creator included no visuals or graphics in the document.

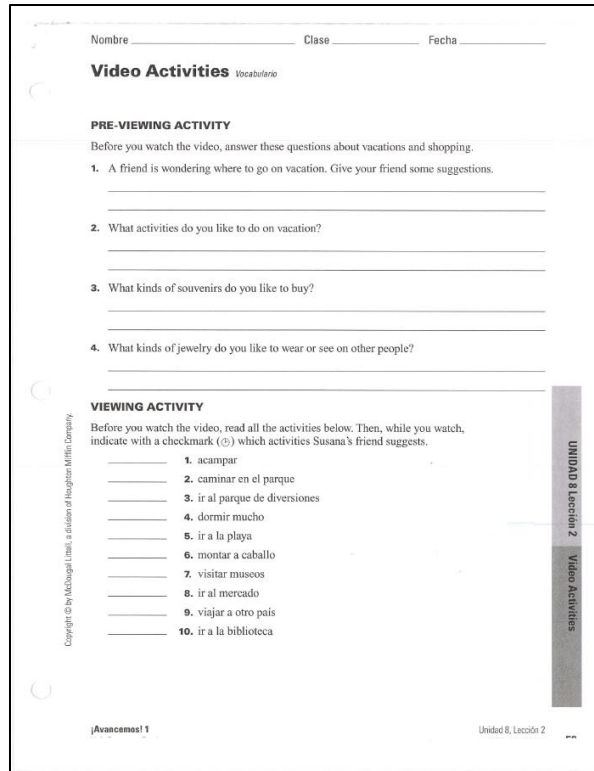

Figure 25. Sample page of Video Worksheet document used in Classroom D.

Technology use in the classroom. Students have multiple options for how they can receive and submit the document, including:

- a digital version shared from the publisher site through email, and submitted as either an edited PDF or a separate word processing document;
- a digital PDF shared through Google Drive, and submitted as either an edited PDF or a separate word processing document;
- projected on a screen and submitted on a separate sheet of paper or word processing document; or,
- received and submitted on a printed paper copy.

The teacher uses *Google Apps for Education*, including Google Drive for document storage, and gives the option of students submitting their responses through a shared

Google Doc. Students receiving a digital copy of the document will most often access the document on their personal laptop.

Cognitive psychology. Most likely, the document length will not have an effect on a student's required level mental effort. The document two pages long, and requires only short answer responses and fill-in-the-blank elements. Regarding external factors, a student's difficulty with the foreign language will affect their ability to complete the document. While the document itself includes no elements of play, the accompanying video played while completing the assignment may include some playful elements not seen on the worksheet.

Document 3: Conversation Cards. Figure 26 below shows a sample page of the Conversation Cards document used in Classroom D. Analysis of this document required completion of the EDDIE form for Supplemental Documents.

The image shows a sample page from a 'Conversation Cards' document. The page is titled 'Conversation Cards Unidad 8, Lección 1'. It is divided into two sections for 'Estudiante A' and 'Estudiante B'. Each section contains the same instruction: '¿Tenemos la misma rutina? Find out if you and your partner have any similarities in your routines. Incorporate the following verbs in your discussion.' Below the instruction is a numbered list of six verbs. For Estudiante A, the verbs are: 1. despertarse, 2. ducharse, 3. acostarse, 4. vestirse, 5. peinarse, 6. cepillarse los dientes. For Estudiante B, the verbs are: 1. bañarse, 2. lavarse la cara, 3. dormirse, 4. peinarse, 5. levantarse, 6. ponerse la ropa. The page also includes a copyright notice on the left side and a footer with the text '¡Avancemos! 1 Conversation Activities' and 'Unidad 8, Lección 1 Conversation Cards 29'.

Figure 26. Sample page of the Conversation Cards document used in Classroom D.

Information design. The Conversation Cards is a publisher-provided document from McDougal Littell publishers. The document was published on an 8.5-inch by 11-inch, letter size paper, with approximately 1-inch margins and using a mixture of serif and sans serif text. In terms of hierarchy, a variety of style elements, including changes in typeface, size, and emphasis, help to clearly differentiate the levels of heading on the page. Color may have been used in the original version of the document. However, as I was given a printed, black and white copy of the document, effective use of color in the document cannot be determined. Outlined boxes help differentiate the different “conversation card” sections. Students respond to the document verbally, so document completion does not require significant response space on the printed page. The document creator did not include any visuals on the page.

Technology use in the classroom. Students have multiple options for how they can receive the document, including

- a digital version shared from the publisher site through email;
- a digital PDF shared through Google Drive;
- a screen projection; or
- a printed paper copy.

Students do not resubmit the document upon completion of the verbal assignment. The teacher uses *Google Apps for Education*, including Google Drive for document storage. Students who receive a digital copy of the document will most often access the document on their personal laptop.

Cognitive psychology. Most likely, the document length will not have an effect on a student’s required level of mental effort. While the document contains four pages of

information, students require very little interaction with the document to complete the task. In terms of external factors that may affect a student's use of the document, a student's difficulty with the foreign language will affect their ability to complete the document. While the document itself includes no elements of play, the resulting conversations from the assignment may include some playful elements not directly seen on the conversation cards.

Document 4: Vocab Slideshow. Figure 27 below shows a sample page of the Vocab Slideshow used in Classroom D. Analysis of this document required use of the EDDIE form for Supplemental Documents.

Information design. The Vocab Slideshow was user-created through an unknown word processing source prior to the classroom use. The slideshow was printed on 8.5-inch by 11-inch paper, and uses a mixture of serif and sans serif text. In terms of hierarchy, the use of size, emphasis, and typeface variation help show importance of the slide headings, with similar style changes occurring throughout the document. The

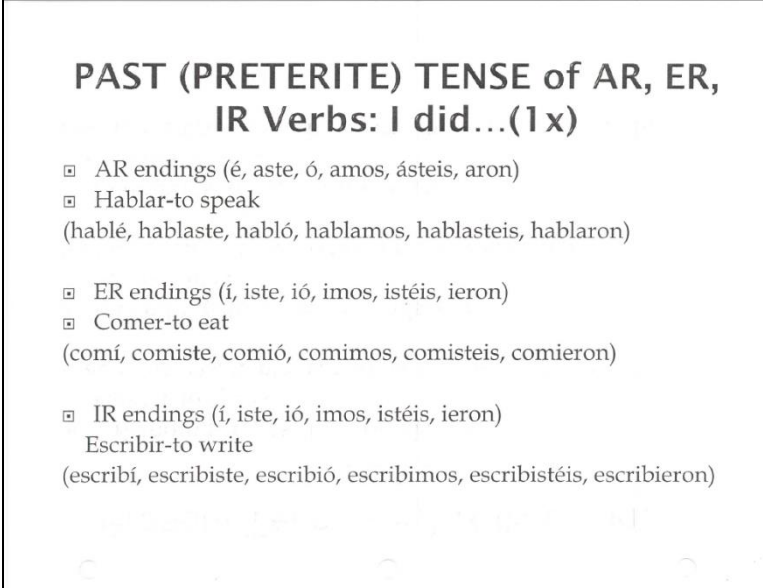

**PAST (PRETERITE) TENSE of AR, ER,
IR Verbs: I did...(1x)**

- ▣ AR endings (é, aste, ó, amos, ásteis, aron)
- ▣ Hablar-to speak
(hablé, hablaste, hablé, hablamos, hablasteis, hablaron)

- ▣ ER endings (í, iste, ió, imos, istéis, ieron)
- ▣ Comer-to eat
(comí, comiste, comió, comimos, comisteis, comieron)

- ▣ IR endings (í, iste, ió, imos, istéis, ieron)
Escribir-to write
(escribí, escribiste, escribió, escribimos, escribisteis, escribieron)

Figure 27. Sample page of the Vocab Slideshow document used in Classroom D.

original slideshow document may have included color, but cannot be seen in this print version. Spacing is used well between elements to show relationships between concepts, particularly on the pages regarding grammar.

The Vocab Slideshow is the only document in Classroom D to include a graphic, shown in Figure 28 below. However, this graphic suffers from poor printing resolution and cannot be interpreted easily as given in the document. Other versions of the document provided to the students may have a more readable version of this graphic, possibly in color. However, such a document was not provided for this study.

Technology use in the classroom. Students have multiple options on how they can receive the document, including as a digital PDF shared through Google Drive, or as a printed paper copy. Students do not resubmit the document upon review.

The teacher uses *Google Apps for Education*, including Google Drive for document storage and sharing. Students receiving a digital copy of the document will most often access the document on their personal laptop.

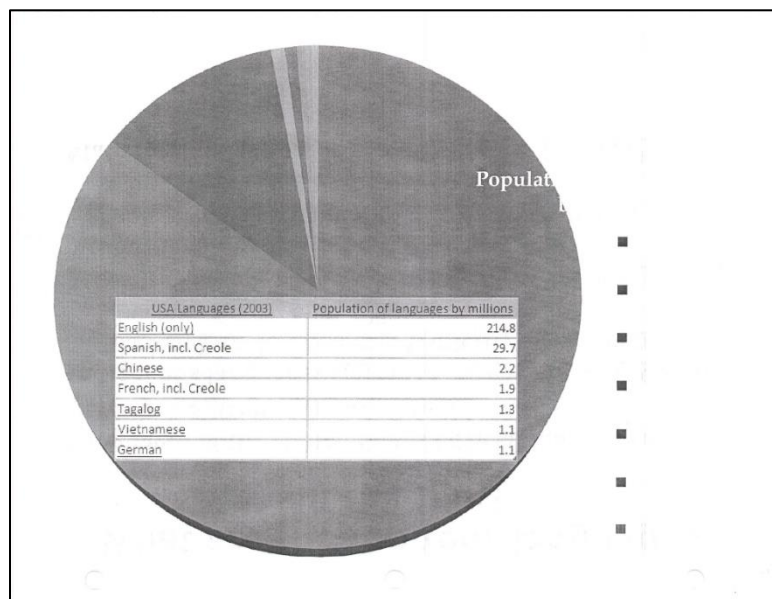

Figure 28. Graphic readability issues in the Vocab Slideshow document.

Cognitive psychology. The document length could have an effect on a student’s required level of mental effort. Although the document is treated as a review guide for students on an as-needed basis, the Vocab Slideshow consists of 27 pages. This number of pages may make it difficult for students to focus on the entire document during a single sitting. Regarding external factors, a student’s difficulty with the foreign language will affect their ability to complete the document. While the document itself includes no elements of play, the resulting conversations from the review period may include some playful elements not directly seen in the slideshow.

Document 5: Transparencies. Figure 29 below shows a sample page of the Transparencies document used in Classroom D. Analysis of this document required completion of the EDDIE form for Supplemental Documents.

TRANSPARENCY 10
Gramática, Unidad 8, Lección 1

Reflexive Verbs

Use **reflexive pronouns** with **reflexive verbs** when the subject in a sentence is the same as its object.

Here's how:

lavarse to wash oneself	
me lavo	nos lavamos
te lavas	os laváis
se lava	se lavan

Many verbs can be used with or without reflexive pronouns. When there is no reflexive pronoun, the person doing the action does not receive the action.

<i>reflexive</i>	<i>not reflexive</i>
Anita se lava .	Anita lava los platos.
Anita <i>washes herself</i> .	Anita <i>washes the dishes</i> .

Do not use possessive adjectives with **reflexive verbs**. Use the **definite article** instead.

Anita **se lava la** cara. Anita *is washing her face*.

When an infinitive follows a conjugated verb, the **reflexive pronoun** can be placed before the **conjugated verb** or attached to the **infinitive**.

Me voy a acostar a las once. I'm going to go to bed at eleven.
or Voy a acostarme a las once.

Some verbs have different meanings when used reflexively.

dormir	to sleep	→	dormirse	to fall asleep
poner	to put	→	ponerse	to put on (clothes)

Copyright © by McDougal Littell, a division of Houghton Mifflin Company.

¡Avancemos! 1 Unidad 8, Lección 1 **10**

Figure 29. Sample page of the Transparencias document used in Classroom D.

Information design. The Transparencies document is a publisher-provided document from McDougal Littell publishers. The document was published on an 8.5-inch by 11-inch letter size paper, with approximately 1-inch margins and using only sans serif text. In terms of hierarchy, a variety of style elements, including changes in size, color, and emphasis help to clearly differentiate importance through levels of heading. Style is used particularly well in the document to differentiate elements, particularly with color use to differentiate and highlight different elements. The designer used elements of emphasis, italics, and effective use of white space throughout the document. No visuals are included in the document.

Technology use in the classroom. Students have a variety of options on how they can receive the document, including

- a digital version shared from the publisher site through email;
- a digital PDF shared through Google Drive;
- a screen projection; or
- a printed paper copy.

Students do not resubmit the document upon review. The teacher uses *Google Apps for Education*, including Google Drive for document storage and sharing, when needed.

Students receiving a digital copy of the document will most often access the document on their personal laptop.

Cognitive psychology. Most likely, the document length will not have an effect on a student's required level of mental effort. While the document contains four pages of information, the information is meant to be used as a review of course concepts.

Regarding external factors, difficulty with the foreign language will affect a student's ability to comprehend the document. The document includes no elements of play.

Document 6: Review Sheet. Figure 30 below shows a sample page of the Review Sheet used in Classroom D. Analysis of this document required use of the EDDIE form for Supplemental Documents.

Information design. The Review Sheet was user-created in Google Docs using a sans serif text. The 8.5-inch by 11-inch, letter size document using standard 1-inch margins. In terms of hierarchy, differentiation of headings occurs through use of text color and highlighting. Size changes are not used for hierarchy. The use of elements of style, including color, italics, and emphasis, helps to show new elements. Frequent use of color shows throughout the document. Spacing is used well to show relationships between elements; however, a large amount of white space remains on the page. The teacher did not include any visuals in this document.

Technology use in the classroom. Students have a variety of options on how they can receive the document, including

- a shared Google Docs page;
- a screen projection; or
- a printed paper copy.

Students do not resubmit the document upon review. The teacher uses *Google Apps for Education*, including Google Docs for document creation and Google Drive for document sharing. Students receiving a digital copy of the document will most often access the document on their personal laptop.



Figure 30. Sample page of the Review Sheet used in Classroom D.

Cognitive psychology. Most likely, the document length will not have an effect on a student's required level of mental effort. Although the document is four pages long, the outline format and frequent use of sentence fragments help to limit mental effort required to comprehend the document. However, some students may find the extensive color use difficult to comprehend, as shown in Figure 29 above. Regarding external factors, difficulty with the foreign language will affect their ability to comprehend the document. While the document itself includes no elements of play, the resulting conversations from the review period may include some playful elements not directly seen in the review content.

This analysis provided an objective look at information found in the completion of the EDDIE forms for the 24 documents provided for the study. This analysis was limited to a listing of qualitative responses provided on each classroom's EDDIE (Educational Document Design and Information Evaluation) forms, including the EDDIEs for Lesson Plans, Adopted Textbooks, and Supplemental Documents.

The Discussion chapter on page 97 that follows examines the patterns found in the document analysis as compared to information in the literature review. Following this discussion, the Recommendations chapter on page 115 lists overall recommendations to teachers at Brandon Hall School based on the found patterns of document design and distribution.

CHAPTER FIVE: DISCUSSION

A document analysis of educational documents at Brandon Hall School has shown how classroom materials follow general conventions of information design and accessibility. This analysis provided an objective look at information found in the completion of the Educational Document Design and Information Evaluation (EDDIE) forms for the 24 documents, including Lesson Plans, Adopted Textbooks, and Supplemental Documents.

This discussion examines the EDDIE forms for patterns among classrooms, grade levels, genres, and document type. The discussion follows the six sections of the Review of the Literature on page 8: Information Design, Textbook Decisions, Implementation of Electronic Textbooks, Technology Use in the Classroom, Cognitive Psychology and How Students Learn, and Lesson Planning and Pedagogical Design.

This chapter answers two of the three research questions for this study, as outlined in the Introduction chapter:

- What are the common themes in current document choices?
- Do current document choices and methods reflect the current recommendations for knowledge retention and understanding as laid out in the present literature?

Information Design

Effective information design helps readers to quickly and easily understand the information in front of them. The analysis of a variety of documents used in the four

classrooms can help teachers to understand how students interact with their document design choices.

The Educational Document Design and Information Evaluation (EDDIE) forms evaluated documents for effective information design through the use of hierarchy, use of style, variation in typeface, spacing, and use of visuals and graphics.

Hierarchy. Hierarchy use in documents seems to depend mostly on the origin of the document and the teacher's design choices. User-created documents and publisher-provided documents provided for analysis implement hierarchy in very different ways.

All publisher-provided documents across the school community use a variety of stylistic changes to show hierarchy in the information. These changes include the use of size, typeface, color, emphasis, and italics to show important elements on the page.

The Worksheet document used in Classroom C demonstrates effective hierarchy in a publisher-provided document. The use of size and emphasis shows the primary purpose and title of the worksheet. Below this information, in slightly smaller text, is the listing of the key concept and the directions. Spacing, typeface, emphasis, and typeface all help relate items to each other and to visually work the reader's eye down the page. The main body text, requiring student response, follows this front-matter information.

For user-created documents on Google Docs, teachers across all four classrooms do little to show hierarchy on the page. Sometimes an outline format is used, which involves incorporating indented bullet points under broader topics. While use of spacing helps show hierarchy, no other elements of style change are used.

In the Chapter Notes document in Classroom A, hierarchy is used opposite of how it should. The documents include formulas that relate to key terms elsewhere in the

document, but these formulas appear much smaller than the remaining body text. However, for a science classroom such as Classroom A, critical information such as formulas should stand out to the student, particularly in a document meant for review. Because the formulas appear smaller than the remaining text, readers might perceive the formulas as less important than the remaining information.

The Google Slides document created for Classroom C is a good exception to the lack of hierarchy across documents. Using a template on the slideshow resulted in highly visible headings through the use of emphasis and color. The reader can clearly see the topic of the current slide, followed by the related information on that topic.

Use of style. For those documents user-created on Google Docs, very few included style changes to differentiate elements or to show relationships between elements. Style element changes of emphasis and underlining appeared most often throughout these user-created documents.

Publisher-provided documents, on the other hand, tend to follow the information design conventions described in the Review of the Literature. This includes the use of size, color, typography, white space, and grouping of elements to show relationships. As noted in the Review of the Literature, an effective use of design convention “acts as a guide that leads the reader through the content” (Apfelbaum & Cezzar, 2014).

The Transparencies document in Classroom D used style exceptionally well to convey information. As the document is used to teach a foreign language, frequent implementation of color and italics help to show relationships between Spanish words and their English translations. For example, when a key term is introduced (such as “reflexive verbs”), the term appears in red text. Immediately following, in a Spanish

sentence, the reflexive verb in that sentence mirrors this color choice, showing the relationship between Spanish word and key term. A sample of this use of style can be seen in Figure 31 below.

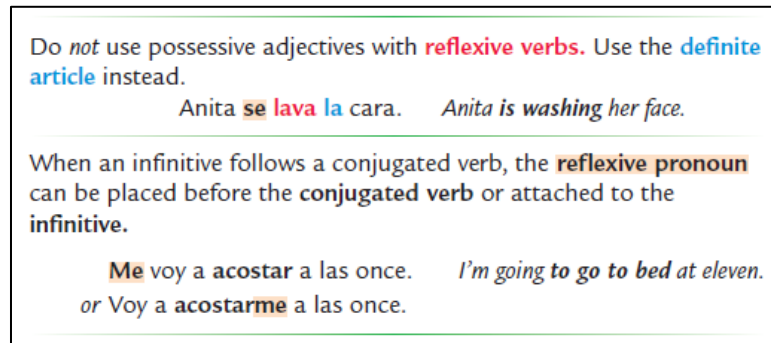

Figure 31. A sample of style use in Classroom D.

Variation in typeface. Among all of the user-created documents, variation in typeface on a single document seems rare. The one major exception, the Vocab Slideshow in Classroom D, uses sans serif headings with serif body text. In addition, the Quiz used in Classroom A uses sans serif text for the heading, and serif text for the remaining content. All other user-created documents use a single typeface throughout the entire document. While text is often underlined, emphasized, or italicized, which alters the look of the type, these fall under stylistic changes as opposed to typeface variation.

Publisher-provided documents all have a variety of both serif and sans serif text. In two of the documents in Classroom D—the Video Worksheet and Conversation Cards—headings and bullet points are written in sans serif text, while remaining body text is written in serif text. The Worksheet in Classroom C uses this same format.

The Textbook page in Classroom B follows a similar format, while still incorporating variations in typeface. The literary content, in the form of a poem on the sample textbook page, is written in serif text. Supplementary information, including

definitions, text analysis question, and notes about the writer’s textual choices, are all written in sans serif text. The title of the poem, while in a serif text, uses a different font altogether, making it stand out from the remaining information on the page.

Spacing. Using space between elements effectively can help direct readers through the content (Apfelbaum & Cezzar, 2014). I evaluated the use of white space in each document, and considered how the use of spacing helped to create visual relationships between elements.

Many of the user-created documents in Google Docs did have effective use of spacing between elements. Documents generally followed one of two trends, including

- every element or bullet point had equal spacing throughout (see the Classroom A Short Answers document in Figure 32 below); or
- each element had significant spacing around it to show a new topic.

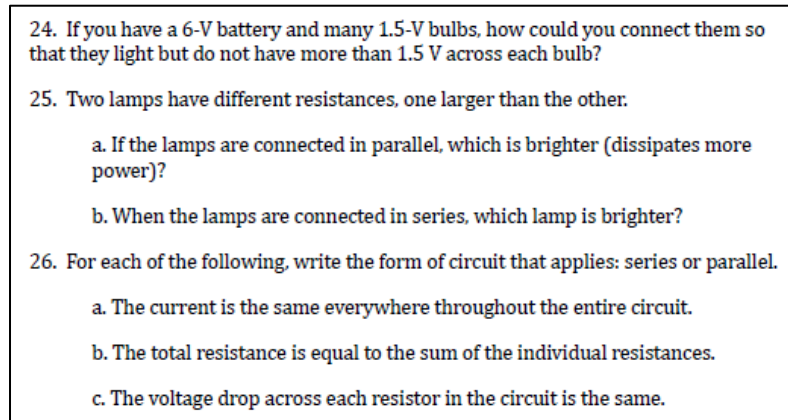

Figure 32. Short Answers document demonstrating consistent spacing throughout.

The Short Story document in Classroom B, shown in Figure 33 below, is an example of a document requiring more spacing considerations to aide student interaction. Poor use of spacing throughout the document results in minimal spacing between paragraphs, and each paragraph beginning with minimal indentation. This lack of spacing

results in elements running together, making it difficult for students to find their position on the page if they get distracted.

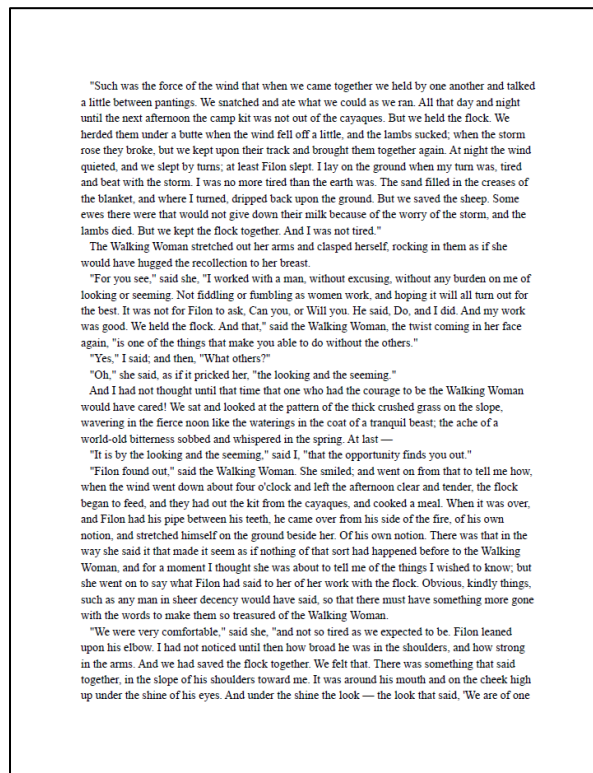

Figure 33. Short Story sample showing spacing issues.

Use of visuals and graphics. As noted in the Review of the Literature, the use of visuals and graphics in document design can be either helpful or detrimental, depending on how it is placed into the surrounding information. Of the 24 documents included for analysis, only seven included either a graphic or a visual—three in Classroom A, two in Classroom B, and one each in Classrooms C and D.

Classroom A, an AP Physics classroom, included graphics in the Chapter Test, Calculations, and Quiz documents. One graphic is a geometry-based physics question, and the others are all circuit drawings. All of these two-dimensional graphics appear very easy to read. Graphics seem well-integrated in their respective documents, as each graphic immediately follows the question or bullet point referencing it.

Classroom B included two visuals, both photographs of only slight relation to the content of the Textbook and the Quiz. These photos act as ambient images that correspond to the information on the page. Once students understand the content, they may be able to better relate the visual to the document content, possibly enhancing their experience of the document.

Classroom C includes three-dimensional graphics on the Chapter Test. In the Review of the Literature, Mikk and Luik (2005) discussed how three-dimensional graphics often distract readers, containing a number of fine details too complex for some students to comprehend. However, for the case of Classroom C, graphics seem simple and easy to understand, primarily used for the sake of identification assessment. These graphics are not as well-integrated into the document as they could be. The graphics could benefit from question number labels placed directly on the graphic to solidify the relationship between graphic and corresponding answer space.

The graphic included in the Vocab Slideshow in Classroom D is of particular concern. The graphic, a large pie chart, lacks print quality and cannot be interpreted easily as presented in the document. Bullet points next to the graphic imply that more information is provided; however, readers cannot see any additional text as part of this information. A label of some sort is partially visible, but seems to have the same color as the background, and therefore cannot be fully understood as shown. This graphic, while related to the content of the document, will likely cause confusion to students reviewing the Vocab Slideshow document.

Textbook Decisions

As a deciding factor in many curricular decisions, textbooks continue to play many roles in the classroom environment. Because of this, teachers must consider many factors when researching textbooks and adopting textbooks to their own class curriculum. Content should match with a teacher's curricular goals, school requirements, and teaching style in order to provide an effective learning experience for the student.

For this study, only one teacher provided a textbook for analysis. Therefore, patterns for textbook decisions across classrooms and grade levels can be difficult to determine. Recommendations will be made for textbook decisions based on this single textbook analysis, and general recommendations following information found in the Review of the Literature.

Information design. Based on the sample page, the textbook information is designed in such a way that students can comprehend and understand the textbook quickly and efficiently. As shown in the analysis of the textbook sample in Figure 23 on page 64, the textbook follows many of the information design conventions associated with effective design. The designer placed the information in separate chunks, which helps make the page readable for students interacting with the page.

Appropriate writing style. For the selected textbook, the calculated Flesch-Kincaid reading levels for two different sample pages seem appropriate for the reading level of students in the course. The sample literary page had a reading level of 8.5, a level appropriate for an eighth-grade student. The text-heavy chapter introduction page, used in the analysis only for readability comparison, scored a reading level of 10.2, appropriate for a student in tenth grade. The majority of students in an American Literature course

will be in Grade 11, meaning the sample reading levels for the chosen textbook are appropriate for the students in the course.

Implementation of Electronic Textbooks

The implementation of an electronic textbook for a course aligns with the school's mission to give students an educational "experience immersed in technology" (Brandon Hall School, n.d., The Mission section). While many teachers have taken to the idea of electronic textbooks in the classroom, this study seeks to determine if electronic textbooks have been implemented successfully.

Static versus interactive. For an eleventh grade literature textbook, the use of a static electronic textbook is appropriate. A textbook likely to contain text-heavy works, particularly a literature textbook, does not necessarily require the interactive features that other courses might benefit from. While the textbook includes some multimedia elements, described in more detail below, these are not interactive in nature.

However, the implementation of a textbook with more interactive features might add some elements of play to the students' learning process. This could include videos, graphics, or animated definitions that complement the learning material in ways that a static textbook cannot.

Multimedia features. The chosen textbook included a variety of multimedia features when accessing the book through the web portal; however, the textbook is static as opposed to interactive. Students access these multimedia features as an aside to the text, as opposed to these features having a full integration into the textbook design.

These multimedia features may not create a seamless electronic textbook experience. For instance, the notetaking ability can be done in other programs on the student's laptop, such as Google Docs, or another word processing platform. In addition, while the content includes URLs to access additional content, these URLs are not hyperlinked. Instead, students must copy and paste the web address into their browser to access this supplemental content.

Student accessibility. For the textbook in Classroom B, students access the textbook through an online web portal, located at *my.hrw.com*, using a unique username and password. Students must have access to the Internet to access their textbook for the course. Through this portal, students can access other textbooks from the same publisher that other teachers may have assigned.

This web portal has positive elements, such as the ability to access multiple textbooks through one login and password. However, this same portal can cause stress to students if not all of their books are accessed through this portal. If a student has teachers who all use different publishers for their textbooks, students will have to keep track of multiple logins to access all of their materials.

Technology Use in the Classroom

According to research by Collins and Halverson (2009), “technology fosters...a more hands-on, activity-based environment.” Brandon Hall’s mission encourages a learning environment immersed in technology. Based on this study, teachers have embraced technology in their creation and distribution of documents in the classroom.

Google Apps for Education. As a whole, for classrooms analyzed in this study, teachers use *Google Apps for Education* well to make classroom documents more accessible to students. Of the 24 documents evaluated, 18 documents were user-created using Google Docs, Google Slides, or Google Forms.

Google Apps for Education is a valuable resource that seems well-implemented in all four classrooms. When teachers share documents with students through Google Drive, Google Docs, or any of the other Google Apps, students can access the documents whenever and wherever they have access to the Internet.

Despite the benefits to implementing *Google Apps for Education* into the everyday curriculum, teachers should also be aware of the drawbacks. If students do not have their device or do not have access to the Internet, they cannot access those educational documents previously shared with them.

In addition, students may have unauthorized access to help during assessments. For instance, students in Classroom B use Google Forms to complete a quiz. During the quiz period, students may have access to information outside of the quiz unless the teacher closely monitor each students' computer activity.

Receiving and submitting documents. Students receive and submit documents in a variety of ways, but similarities appear across single classrooms. Of the 24 documents provided for analysis, 19 can be shared digitally with students through *Google Apps for Education*.

Some teachers choose to distribute documents in the form of a physical paper copy. Based on the analysis, teachers who choose to distribute documents as a paper copy have a specific reason for doing so.

The teacher of Classroom D in particular does an excellent job at providing options for how students choose to receive and submit their classroom documents. Students can choose to receive their documents in a way that best suits their own learning style, whether they prefer a paper copy, a digital copy, or a projected copy of the document. In addition, in Classroom D, students can choose to resubmit their documents in whichever way that works best for their own personal learning style, either by creating a new digital document, editing a PDF document, writing out a physical copy, or something else that might work better for them.

The teacher of Classroom C takes a student's needs into perspective when determining the best way to distribute the document. For documents such as worksheets, the teacher distributes documents digitally through Google Drive. For the Chapter Test, however, the teacher is aware of the possible distractions when middle school students access documents on a computer. Therefore, the teacher of Classroom C distributes the Chapter Test as a physical copy to minimize distractions during the assessment.

Devices used for access. For digitally-distributed documents, students will typically access the documents on their personal laptop computer, which Brandon Hall School requires of all students for enrollment. Teachers will often access digital documents on their personal laptop, but may also access them on their iPad as needed. When documents are distributed as non-digital versions, electronic devices such as laptops and iPads are not used, with the possible exception of a projector system in the classroom to view the document.

Cognitive Psychology and How Students Learn

Each student will interact with a given document differently based on their personality and their past experiences. While teachers can't predict everything that might affect a student's interpretation of a document, they can perform an audience analysis to determine what might work best for the majority of student scenarios. When teachers understand the cognitive factors of document design that affect student learning, they can select and create documents that better enforce learning and recall.

Effects of document length on mental effort. Document lengths and the related effects on mental effort seem to vary by classroom and by subject. While many documents are of minimal length and would likely have no effect on mental effort, others contain much more information and may cause issues for students.

However, it is worth noting that the analysis of document length may be more subjective than other criteria in this study. What one student finds long and arduous, another might have no issues with.

Classroom A uses a mix of documents that might have document length concerns. The Short Answers document, for instance, is just over two pages long. However, the document contains 27 questions, with some requiring multiple responses. Students may find it difficult to make it through the entire assignment in one sitting, as the level of mental effort required would be very high. The one-page Quiz, on the other hand, requires only three questions, resulting in minimal mental effort.

Elements of play. Only Classroom C, the middle school science classroom, explicitly included elements of play in two of the documents. The Chapter Test included

an option to write a content-related joke for bonus points, and the Scavenger Hunt encourages students to learn outside the classroom using a hands-on lesson.

These elements of play included in middle school-level documents fits well for the age group and how they learn. As noted in the Review of the Literature in Chapter Two, using play as a learning technique can help encourage students to actively participate in the learning process. Particularly in the case of the Scavenger Hunt, “the introduction of a puzzle or a problem to be solved immediately grabs people’s attention, as they perceive that there will be something interesting and worthwhile involved in the process” (Cook and Klipfel, 2015).

In Classroom D, while the documents do not directly include elements of play, some play can be included when interacting with the course content. These document designs do not effect how much play students choose to include during the assignment.

External factors. Determining external factors that affect student use of the document can prove difficult for teachers. Every student will have unique external factors that affect their interpretation and interaction with a given document. However, teachers can take some factors into consideration, regardless of the individual student.

For Classroom A, the stress of completing AP-level tasks and assessments can cause significant stress to the student. AP-level courses typically compare to collegiate courses, which some students might not be prepared for. This stress may affect how they interpret a particular document. “Mood and psychological states can influence perceptions, memory, and judgments of attributes” (Weinstein, Legate, & Przybylski, 2013). As a result, a student who encounters an assessment while stressed might read the document differently than a student who encounters it with less stress. As a result, the

student encountering stress during the document interaction might end up with a lower score due to stress factors.

A similar concept arises in Classroom D. In a foreign language classroom such as Classroom D, students build upon previous knowledge to develop their abilities in the language. If a student has difficulty with this new language and falls behind, he or she will have more difficulty trying to interpret documents which include the foreign language as the primary language.

The teacher of Classroom C has different external factors to consider; namely, the teacher must consider the moods and interactions of younger students in the middle school grade levels. For the Scavenger Hunt document, students must work together in groups to answer clues and navigate around the campus. The teamwork element of the assignment may cause stress to the student if personalities and learning styles do not match while completing assignment requirements. If students have issues with the teamwork element and do not cooperate successfully, this may affect how they read and interact with the printed document.

Lesson Planning and Pedagogical Design

A strong pedagogical design for classroom instruction provides a foundation for how students will interact with documents in the classroom. Once a teacher determines the best methods of instruction for their students based on what they expect the students to learn, they can then plan for “instructional materials, methods, and assessments” (Courey, Tape, Siker, & LePage, 2012) and can develop an effective lesson plan. Of the

four classrooms that volunteered documents for the study, three included lesson plans as one of their documents.

Information design of lesson plans. The lesson plans provided for analysis follow one of two general formats, including

- three columns on a horizontal page, including one week’s classwork and homework assignments; or
- four columns on a vertical page, including the unit, time frame, performance standards, learning objectives, and performance tasks.

The lesson plan in Classroom B follows the horizontal format, and the lesson plans in Classrooms C and D follow the vertical format.

The vertical format proves detrimental to document use. The use of four columns on a vertical page results in very narrow columns. When one column has a large amount of information, the document becomes difficult to read quickly, shown in Figure 23 on page 83. As a result, entire columns are left empty on a page, which is an inefficient use of space on the page.

Outline of the “why.” As noted in the Review of the Literature starting on page 8, when students begin to understand the reasoning behind a specific lesson, they can apply this to their own leaning needs. From there, students can examine their needs of the lesson and adjust appropriately.

Of the three lesson plans provided for analysis in the study, two outline the “why” through the inclusion of performance standards and learning objectives for each lesson. The third lesson plan, from Classroom B, only lists assignments and tasks given in a one-week period.

While these two lesson plans outline the “why” of the lessons, this does not guarantee that the student has access to the information. The teachers must decide for themselves if they will provide this information along with the lesson, and particularly if they choose to integrate the information into the documents.

Objectives per period. Of the three lesson plans provided, only the lesson plan for Classroom B clearly showed a number of objectives per class. For this classroom, each class period lists two to three objectives, within the acceptable range of objectives for student mental effort. By limiting the amount of objectives to two to three per class period as suggested by Burke (2015) and Cook and Klipfel (2015), students are less likely to experience a mental overload.

For the lesson plans provided in Classrooms C and D, the unit-based format of the grid does not allow for the listing of objectives per period. Instead, these plan designs list a large number of performance standards, learning objectives, and performance tasks within a unit to be covered over a multiple-week period.

Universal Design for Learning (UDL). With the three lesson plans provided, the effective implementation of UDL is difficult to determine. Classroom B provides the only possible inclusion of UDL. The teacher describes an iMovie project in which “the projects are individual in nature.” Because of this, students can apply their own learning styles to their project in a way that personally works for them.

Problem-Based Learning (PBL). With the three lesson plans provided, the effective implementation of PBL is difficult to determine. Classroom C provides the only possible inclusion of PBL. On the Scavenger Hunt assignment, students must solve location-based problems outside of the classroom. As Topal et al. (2015) suggest,

problem-based learning assignments such as the Scavenger Hunt can help students “learn efficient problem-solving, independent learning, and learn to monitor themselves as well as by teamwork.”

This discussion provided an examination of patterns found in the completion of the EDDIE forms for the 24 documents, as shown in the Analysis chapter starting on page 52. The discussion followed the six sections of the Review of the Literature on page 8: Information Design, Textbook Decisions, Implementation of Electronic Textbooks, Technology Use in the Classroom, Cognitive Psychology and How Students Learn, and Lesson Planning and Pedagogical Design.

The Recommendations chapter following on page 115 lists the overall recommendations to teachers at Brandon Hall School based on the found patterns of document design and distribution.

CHAPTER SIX: RECOMMENDATIONS

This chapter answers one of the three research questions for this study, as outlined in the Introduction chapter: How can teachers improve their document choices in the classroom to promote student retention and understanding?

The recommendations made in this chapter are based on the information found in the Analysis chapter on page 52, and the patterns discovered through this data in the Discussion chapter on page 97. The recommendations follow the three types of Educational Document Design and Information Evaluation (EDDIE) forms used to analyze the classroom documents: Supplemental Textbooks, Lesson Plans, and Adopted Textbooks.

Supplemental Documents

For this study, a supplemental document refers to a user-created or publisher-provided classroom document (aside from a lesson plan or textbook) that students receive and interact with in some way. Supplemental documents provided for analysis covered a wide variety of document types. These documents included quizzes, chapter tests, final exam reviews, chapter notes, daily assignments, slideshows, and more.

Information design. User-created documents in Google Docs should follow information design conventions of hierarchy, use of style, variation in typeface, spacing, and use of visuals and graphics. Following are recommendations for how Brandon Hall School teachers can apply style to documents to differentiate elements:

- Create headings that are larger than remaining body text and of a different typeface.

- Use color to highlight key elements or terms.
- Add an extra line of space when starting a new element.
- Use emphasis and/or italics to show items or terms of note.
- Make clear reference to any included graphics or visuals in the document, while also including extra space between the graphic/visual and text.

Teachers should pay particular attention to the implementation of style changes in Google Docs. As a default, teachers at Brandon Hall School tend to use minimal style changes in user-created Google Docs to differentiate elements on the page. Teachers should practice changing type size, typeface, color, shape, and emphasis in important elements to show hierarchy and importance.

As an example, I've done a simple redesign in Google Docs of the Study Guide used in Classroom A. In the redesign shown below in Figure 34, I used simple stylistic changes of type size, typeface, color, and emphasis, and added additional spacing between new elements.

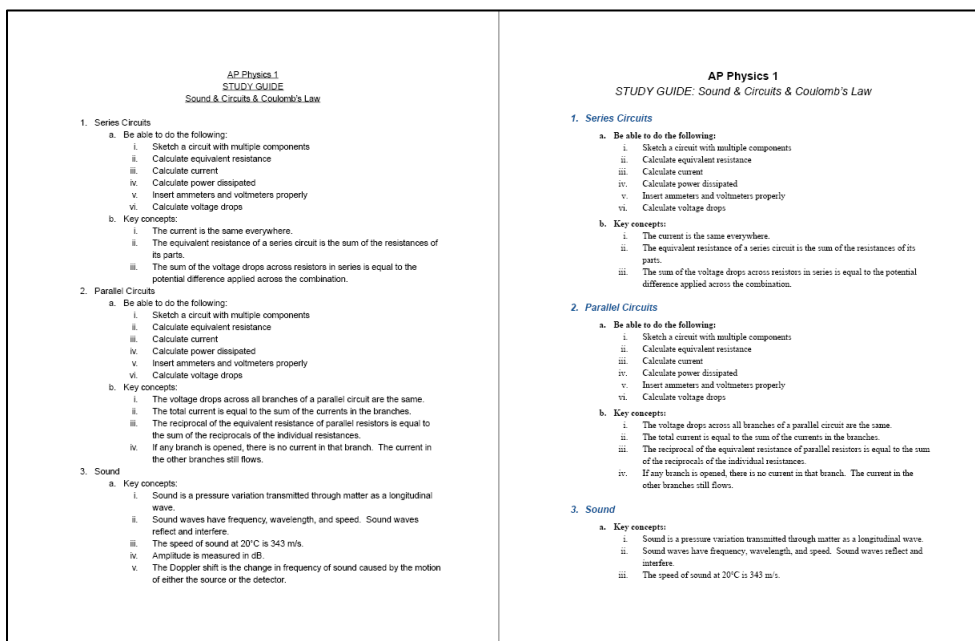

Figure 34. Before and after of sample document redesign on Google Docs.

While the changes in the document are minor and take a small amount of extra time, major concepts are easier to find when scanning the study guide. Style changes like this can be implemented in all classroom and documents.

Technology use in the classroom. At this point in time, all four classrooms effectively use *Google Apps for Education*. As this program has become the standard method of document distribution at Brandon Hall, teachers with less knowledge of the program should work to familiarize themselves with more of the *Google Apps for Education* programs and their benefits to the classroom.

Cognitive psychology. Analysis of a document's elements of cognitive psychology relate to document length, mental effort, elements of play, and external factors affecting document interactions. Understanding how a student thinks and reacts when interacting with a document can help teachers better understand how their choices might directly or indirectly affect student learning.

Document length and mental effort. Teachers should understand the level of mental effort required to understand and complete the documents they create and choose to include in their classroom. Saparova and Nolan (2016) define mental effort as “the cognitive capacity allocated by the learner when working on a task.” If a document requires too high a level of mental effort, students may not learn and understand the material as intended. Creating documents or selecting publisher-provided documents for the classroom that do not overload a student's mental effort, will be critical to a student's retention of new material.

Many of the user-created documents in the analyzed classrooms include large amounts of text with little spacing. The Short Story document used in Classroom B is one

such example of minimal spacing. As a result, students may find it difficult to focus on the information. This can be remedied by adding additional spacing to document to show relationships and differences between certain elements.

Teachers should also consider the length of the document for courses with more difficult content. For example, Classroom A, the AP Physics classroom, uses lengthy documents that require a number of short answer responses. The level of mental effort required to complete such assignments in one sitting may be very high for some students. To lessen this mental effort, teachers can divide the assignment into smaller chunks for completion, or allow students to complete the document over a longer period of time. Integrating other elements into the assignment that require less mental effort can also help a student to “recharge” between more strenuous elements.

Some classes, like American Literature and AP Physics, can be intense simply because of the nature and content of the course. However, taking mental effort into consideration can help teachers create and select documents that make the information a little more manageable for students.

Elements of play. Teachers should not feel obligated to include elements of play in their documents. However, teachers should also be knowledgeable as to how elements of play can both help and hurt students. Should teachers choose to involve play or educational games into their curriculum, they must find a balanced level of play that works best for the students’ productivity and retention.

The inclusion of play into educational documents is better suited for the middle school grades at Brandon Hall School. These younger students require more stimulation

to stay engaged in the classroom and with the content. Using play as a learning technique can help encourage students to actively participate in the learning process.

External factors. Any number of external factors can affect how a student interacts with a classroom document, often out of the teacher's control. However, awareness of some of these external factors can help the teacher to prepare for any issues that may arise.

Two such external factors include mood and stress levels. A student who encounters an assessment while stressed or while experiencing a negative mood might read the document differently than a student who encounters it with less stress or under a different mood, possibly resulting in a lower score due to the different state. To help combat this, teachers can use stylistic elements to divide documents into smaller chunks for the student to focus on when stressed. Also, teachers can allow the student to step away for a moment to "recharge" their thoughts, or even provide students with a separate assignment that still achieves the same learning objectives in a different way.

Previous experiences can also affect student interaction. As noted in the Review of the Literature, "positive psychological experiences may relate to, but do not equate, evaluations of beauty in the physical world" (Weinstein, Legate, & Przybylski, 2013). A student who has had pleasant experiences with mathematics, for example, might have more positive psychological experiences and see a document as more aesthetically pleasing than a student who has continually had negative mathematics experiences.

If a teacher is aware of a student having negative experiences in their subject, there are opportunities to create a new document for these students. These special documents can address that student's negative experiences while still achieving the same

learning objectives as the primary document. This might involve only minor changes to the document to address the issue.

Lesson Plans

Developing an effective lesson plan for students begins with understanding student needs and applying that to pedagogical goals for a given course. Based on the three lesson plans provided for analysis, teachers at Brandon Hall School have a strong basis for classroom instruction, but could use improvement on the design of individual lesson plan documents.

Lesson planning and pedagogical design. Problem-Based Learning (PBL) and Universal Design for Learning (UDL) are important curricular elements for student learning. However, determining the use of these concepts in the classroom simply through lesson plan analysis is not effective. Unless the lesson plans explicitly list these concepts, there is no way to determine if teachers use these concepts in their current plan.

Teachers might want to consider explicitly listing methods for PBL and UDL in their lesson plans. Doing so might help teachers (and substitute teachers, should that need arise) see different ways for students to achieve a specific objective in a way that suits their own learning style.

The inclusion of performance standards and learning objectives works well for helping teachers to remember the “why” of the daily lesson or the unit. Teachers should also consider ways of including these objectives in their user-created document designs, and this may help students better understand the content. When students understand the

“why” behind a specific lesson, they can apply this information to their own learning needs and adjust appropriately.

Information design. Teachers should consider the orientation of the page when designing their lesson plans. When a lesson plan calls for multiple columns, using a horizontal page layout will allow more space in the columns for necessary information, as shown below in Figure 35. This design also allows for one unit’s worth of lesson plan information to be on a single page, requiring less page turning when finalizing classroom activities based on the lesson plan.

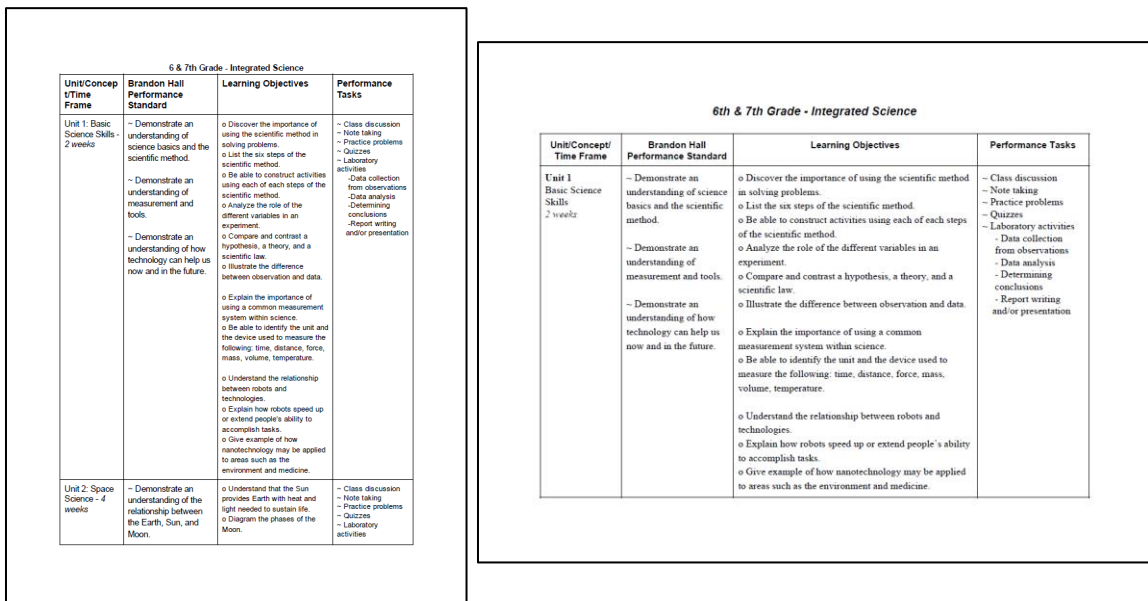

Figure 35. Before and after of sample 4-column lesson plan layout on Google Docs.

Teachers might also consider the use of information design conventions used for supplemental documents and textbooks. Adding style and spacing elements to their lesson plans might help teachers to better understand their own planning needs. This recommendation could have a greater effect on those lesson plans organized by unit, as the inclusion of stylistic elements can help break down objectives into smaller, manageable sections.

Technology use in the classroom. Teachers should continue their use of Google Docs to create their lesson plans, and Google Drive to store their lesson plans. This use of *Google Apps for Education* allows teachers to access their plans wherever they have Internet access, and change their plans as needed without the limitation of being inside the classroom.

Adopted Textbooks

As only one teacher provided a textbook for analysis in this study, patterns for adopted textbook across the entire school culture were difficult to determine. These recommendations are based on what was learned from this classroom's textbook choices, information found during the literature review, and observations made during the analysis phase.

Textbook decisions. When considering the adoption of a new textbook for a course, teachers should ensure they take the student's educational experience into top priority. Teachers should ask themselves a variety of questions when evaluating a textbook for classroom adoption:

- Will a textbook benefit my students and my curriculum?
- Do the textbook pages seem to follow basic information design conventions?
- Do the textbook content and reading level align with the age range and curriculum of the course?
- What multimedia tools are included to help with learning?
- Will students be able to access the textbook efficiently and in a way that works for their learning style?

Asking questions such as these will help teachers ensure that the textbook they adopt for their classroom is the best option for the students in that course.

Implementation of electronic textbooks. While Brandon Hall supports the mission of immersing students in a 21st century classroom, teachers should consider whether an electronic textbook is the best fit for their classroom. Teachers should evaluate the positives and negatives of adopted a digital textbook, and determine which will work better for the student and for the classroom objectives.

Teachers should evaluate a sample of the textbook whenever possible to determine if the access platform is easy to understand and works for their style of teaching. In addition, a sample textbook can provide teachers with valuable information on whether the digital textbook is static or interactive. With interactive textbooks, teachers should determine if these multimedia aspects will enhance the learning experience or make the experience more difficult.

Technology use in the classroom. Teachers should have a plan for textbook use should the digital version become inaccessible for any reason. This might include having digital PDF or paper copies of the required textbook pages for distribution, or lesson plans that do not require the textbook.

Information design. When a textbook is implemented as a primary learning method in a course, effective information design on textbook pages is critical to effective student learning. Teachers should familiarize themselves with effective information design conventions of hierarchy, style, typeface, spacing, graphics, and visuals. Once they have this knowledge, teachers should evaluate potential textbooks for proper use of

these conventions. If a chosen textbook does not follow information design conventions, the textbook will only hinder effective student learning.

Cognitive psychology. Teachers should evaluate the reading level of the textbook to ensure the textbook's grade-level appropriateness for students taking the course. Teachers can evaluate the reading level by copying text from the document into a Microsoft Word document, and using the program's tools to determine the Flesch-Kincaid Reading Level of the selected material.

These recommendations, though based on the research found in the Review of the Literature and the patterns found in the Analysis and Discussion chapters, are not finite in nature. Teachers should consider their own student and curricular needs when determining the best methods of document design and distribution in their own classrooms.

CHAPTER SEVEN: CONCLUSIONS

Brandon Hall School, a small private day and boarding school, is a school focused on individualized curriculum and experience. This qualitative, industrial ethnographic study has examined how teachers at Brandon Hall School select and design documents for inclusion in the classroom, and compared this information to the current trends in the areas of information design and distribution. With this information, teachers can continue to provide the individualized experience for students in the area of educational documents used in the classroom.

The Review of the Literature examined the current literature to determine the current best practices of information design, decisions, and distribution as it relates to educational documents. The research focused on six key themes that affect educational document design: Information Design, Textbook Decisions, Implementation of Electronic Textbooks, Technology Use in the Classroom, Cognitive Psychology and How Students Learn, and Lesson Planning and Pedagogical Design.

The Methodology chapter went into details of the teacher recruitment process and the document selection process for the study. The methodology included an introduction of Educational Document Design and Information Evaluation (EDDIE) forms as the qualitative instrument for the study, as well as details and criteria for the document analysis process. Four classrooms with six documents each provided a total of 24 classroom documents for analysis.

The Analysis chapter created a listing of objective, qualitative responses provided following the completion each classroom's EDDIE forms. This included EDDIE forms

for Lesson Plans, Adopted Textbooks, and Supplemental Documents. Analysis sections were completed by classroom.

The Discussion chapter answered two of the three research questions for this study, as outlined in the Introduction chapter:

- What are the common themes in current document choices?
- Do current document choices and methods reflect the current recommendations for knowledge retention and understanding as laid out in the present literature?

This discussion examined the EDDIE forms for patterns among classrooms, grade levels, genres, and document type. The discussion follows the six sections of the Review of the Literature in Chapter Two: Information Design, Textbook Decisions, Implementation of Electronic Textbooks, Technology Use in the Classroom, Cognitive Psychology and How Students Learn, and Lesson Planning and Pedagogical Design.

Recommendations were given based on the third research question of this study: How can teachers improve their document choices in the classroom to promote student retention and understanding? Recommendations compared information found in the Analysis and Discussion to the information gathered in the Review of the Literature to determine the best practices for classroom documents. Recommendations were given in line with the three EDDIE form types: Supplemental Documents, Lesson Plans, and Textbooks.

Overall, this study has found that the teachers at Brandon Hall School have chosen and created educational documents based on the individual student needs in the classroom. A mix of user-created and publisher-provided document have shown a strong trend towards a variety of documents used in the classroom. However, teachers need more knowledge in the area of adding stylistic changes to their user-created documents to ease comprehension and understanding for students.

Along with the Dean of Faculty at Brandon Hall School, I plan to develop the recommendations given in this study into a guide, which will be distributed to teachers during the 2016-2017 academic year. While these recommendations are not finite, teachers can make more informed decisions regarding their classroom documents, and can alter some of their current documents to better suit the design needs of their students.

List of References

- Amirault, R. J., & Visser, Y. L. (2015). Technology transience: Opportunities, challenges, and implications. *The Quarterly Review of Education, 16*(2), vii-ix. Retrieved from <http://www.infoagepub.com/qrde-issue.html?i=p55a9224047979>
- Apfelbaum, S., & Cezzar, J. (2014). *Designing the editorial experience: A primer for print, web, and mobile*. Beverly, MA: Rockport Publishers.
- Baek, J.-S., & Lee, K.-P. (2008). A participatory design approach to information architecture design for children. *CoDesign, 4*(3), 173-191. doi:10.1080/15710880802281026
- Bain, A., & Weston, M. E. (2012). *The learning edge: What technology can do to educate all children*. New York, NY: Teachers College Press.
- Bauer, J., & Kenton, J. (2005). Toward technology integration in the schools: Why it isn't happening. *Journal of Technology and Teacher Education, 13*(4), 519-546.
- Bhagat, A., Vyas, R., & Singh, T. (2015). Students awareness of learning styles and their perceptions to a mixed method approach for learning. *International Journal of Applied and Basic Medical Research, 5*, S58-S65. doi:10.4103/2229-516X.162281
- Brandon Hall School. (n.d.-a). Facts about Brandon Hall School. Retrieved from <http://brandonhall.org/about-brandon-hall/fact-sheet/>
- Brandon Hall School. (n.d.-b). Mission, Philosophy and Vision. Retrieved from <http://brandonhall.org/about-brandon-hall/mission/>
- Brandon Hall School. (n.d.-c). Technology at Brandon Hall School. Retrieved from <http://brandonhall.org/current-families/technology/>

- Brandon Hall School. (n.d.-d). Why Choose Brandon Hall School? Retrieved from <http://brandonhall.org/admissions/why-brandon-hall/>
- Browne, G., & Coe, M. (2012). Ebook navigation: Browse, search, and index. *Australian Library Journal*, 61(4), 288-297. Retrieved from <http://search.proquest.com/docview/1242448210?accountid=11824>
- Bryce, N. (2011). Meeting the reading challenges of science textbooks in the primary grades. *The Reading Teacher*, 64(7), 474-485. doi:10.1598/RT.64.7.1
- Burke, J. (2015). Teaching by design: Tools and techniques to improve instruction. *Journal of Adolescent & Adult Literacy*, 59(3), 249–260. doi:10.1002/jaal.413
- Butean, A., Morar, A., Moldoveanu, A., & Alexandru, M. (2015, April 23-24). *From classic math school books to interactive gamified eLearning*. Paper presented at The 11th International Scientific Conference eLearning and Software for Education, Bucharest. doi:10.12753/2066-026X-15-022
- Ceylan, S., & Ozdilek, Z. (2014, July 12-14). *Improving a sample lesson plan for secondary science courses within the STEM education*. Paper presented at Global Conference on Contemporary Issues in Education, Las Vegas, USA. doi:10.1016/j.sbspro.2015.02.395
- Cheng, M.-T., Su, T., Huang, W.-Y., & Chen, J.-H. (2014). An educational game for learning human immunology: What do students learn and how do they perceive? *British Journal of Education Technology*, 45, 820-833. doi:10.1111/bjet.12098
- Collins, A., & Halverson, R. (2009). *Rethinking education in the age of technology: The digital revolution and schooling in America*. New York, NY: Teachers College Press.

- Cook, D. B., & Klipfel, M. K. (2015). How do our students learn? An outline of a cognitive psychological model for information literacy instruction. *Reference & User Services Quarterly*, 55(1), 34-41. doi:10.5860/rusq.55n1.34
- Courey, S. J., Tappe, P., Siker, J., & LePage, P. (2012). Improved lesson planning with Universal Design for Learning (UDL). *Teacher Education and Special Education*, 36(1), 7-27. doi:10.1177/0888406412446178
- de Oliveira, J., Camacho, M., & Gisbert, M. (2014). Exploring student and teacher perception of e-textbooks in primary school. *Media Education Research Journal*, XXI, 87-95. doi:10.3916/C42-2014-08
- Derla, K. (2016, February 5). More than 90 percent of college students prefer reading paper books over e-books. *Tech Times*. Retrieved from <http://www.techtimes.com>
- Diezmann, C. M., & Lowrie, T. (2012). Learning to think spatially: What do students 'see' in numeracy test items? *International Journal of Mathematics Education*, 10, 1469-1490. doi:10.1007/s10763-012-9350-3
- Elam, K. (2004). *Grid systems*. New York, NY: Princeton Architectural Press.
- Erbaş, A. K., Alacaci, C., & Bulut, M. (2012). A comparison of mathematics textbooks from Turkey, Singapore, and the United States of America. *Educational Sciences: Theory & Practice*, 12, 2324-2329. Retrieved from www.edam.com.tr/estp
- Erceg, N., & Aviani, I. (2014). Students' understanding of velocity-time graphs and the sources of conceptual difficulties. *Croatian Journal of Education*, 16(1), 43-80. Retrieved from <http://cje2.ufzg.hr/ojs/index.php/CJOE/article/view/505>

- Falc, E. O. (2013). An assessment of college students' attitudes towards using an online e-textbook. *Interdisciplinary Journal of E-Learning and Learning Objects*, 9, 1-12. Retrieved from <http://www.ijello.org/Volume9/IJELLOv9p001-012Falc831.pdf>
- Farkas, D. K., & Raleigh, C. A. (2013). Designing documents for selective reading. *Information Design Journal*, 20(1), 2-15. doi:10.1075/idj.20.1.01far
- Friesen, N. (2013). The past and likely future of an educational form: A textbook case. *Educational Researcher*, 42, 498-508. doi:10.3102/0013189X13513535
- Fryer, L. K., Ginns, P., & Walker, R. (2014). Between students' instrumental goals and how they learn: Goal content is the gap to the mind. *The British Psychological Society*, 84, 612-630. doi:10.1111/bjep.12052
- Hocks, M. E., & Kendrick, M. R. (Eds.). (2003). *Eloquent images: Word and image in the age of new media*. Cambridge, MA: The MIT Press.
- Huang, K.-L., Chen, K.-H., & Ho, C.-H. (2014). Enhancing learning outcomes through new e-textbooks: A desirable combination of presentation methods and concept maps. *Australasian Journal of Educational Technology*, 30(5), 600-618. doi:10.14742/ajet.v30i5.538
- Jokinen, J. P. P. (2014). Emotional user experience: Traits, events, and states. *International Journal of Human-Computer Studies*, 76(2015), 67-77. doi:10.1016/j.ijhcs.2014.12.006
- Juban, R. L., & Lopez, T. B. (2013). An exploration of textbook reading behaviors. *Journal of Education for Business*, 88, 325-331. doi:10.1080/08832323.2012.721023

- Kang, Y.-Y., Wang, M.-J., & Lin, R. (2009). Usability evaluation of e-books. *Displays*, 30(2009), 49-52. doi:10.1016/j.displa.2008.12.002
- Kilic, C. (2013). Turkish primary school teachers' opinions about problem posing applications: Students, the mathematics curriculum and mathematics textbooks. *Australian Journal of Teacher Education*, 38(5), 144-155. doi:10.14221/ajte.2013v38n5.10
- Kostelnick, C. & Hassett, M. (2003). *Shaping information: The rhetoric of visual convention*. Carbondale, IL: Southern Illinois University.
- Lagrange, J.-B., & Erdogan, E. O. (2008). Teachers' emergent goals in spreadsheet-based lessons: Analyzing the complexity of technology integration. *Educational Studies in Mathematics*, 71(1), 65-84. doi:10.1007/s10649-08-9160-2
- Lee, H. J., & Yau, K. A. (2015). Addressing the major information technology challenges of electronic textbooks. *Journal of Computer Information Systems*, 55(2), 40-47. doi:10.1080/08874417.2015.11645755
- Lee, K., Tsai, P.-S., Chai, C. S., & Koh, J. H. L. (2014). Students' perceptions of self-directed learning and collaborative learning with and without technology. *Journal of Computer Assisted Learning*, 30, 425-437. doi:10.1111/jcal.12055
- Lim, C., Song, H.-D., & Lee, Y. (2011). Improving the usability of the user interface for a digital textbook platform for elementary-school students. *Educational Technology Research and Development*, 60, 159-173. doi:10.1007/s11423-011-9222-5
- Lipton, R. (2007). *The practical guide to information design*. Hoboken, NJ: John Wiley and Sons.

- Logofătu, B., & Vișan, A. (2015, April 23-24). New trends in the educational area: Case study regarding the usability of Google Apps tools within the department for distance learning. Paper presented at The 11th International Scientific Conference eLearning and Software for Education, Bucharest. doi:10.12753/2066-026X-15-171
- Lonsdale, M. dos S. (2014). The effect of text layout on performance: A comparison between types of questions that require different reading processes. *Information Design Journal*, 21(3), 279-299. doi:10.175/idj.21.3.09san
- Lowrie, T., Diezmann, C. M., & Logan, T. (2011). Understanding graphicacy: Students' making sense of graphics in mathematics assessment tasks. *International Journal for Mathematics Teaching and Learning*, 1-32. Retrieved from <http://www.cimt.plymouth.ac.uk/journal/lowrie.pdf>
- McGhie-Richmond, D., & Sung, A. N. (2013). Applying Universal Design for Learning to instructional lesson planning. *International Journal of Whole Schooling*, 9(10), 43-59. Retrieved from <http://files.eric.ed.gov/fulltext/EJ1016798.pdf>
- McNeish, J., Foster, M., Francescucci, A., & West, B. (2012). The surprising foil to online education: Why students won't give up paper textbooks. *Journal for Advancement of Marketing Education*, 20(3), 58-69. Retrieved from <http://www.mmaglobal.org/publications/JAME>
- Mejía, G. M. (2013). Visual intelligence and mood in visual communication design. *Information Design Journal*, 20(1), 47-57. doi:10.1075/idj.20.1.04mej

- Mikk, J., & Luik, P. (2005). Do girls and boys need different electronic books?
Innovations in Education and Teaching International, 42(2), 167-180.
doi:10.1080/14703290500062565
- Numanoglu, G., & Bayir, S. (2009). Evaluation of information and communication technology textbooks according to principles of visual design. *Procedia Social and Behavioral Sciences*, 1, 2140-2144. doi:10.1016/j.sbspru.2009.01.375
- Oruç, Ş., Uğurlu, N. B., & Tokcan, H. (2010). Using graphic illustrations with social studies textbooks. *Procedia Social and Behavioral Sciences*, 2, 1037-1042.
doi:10.1016/j.sbspro.2010.03.146
- Piht, S., Raus, R., Kukk, A., Martin, K., & Riidak, K. (2013). Students' interpretations of the 6th grade science textbook design. *Procedia Social and Behavioral Sciences*, 112, 861-872. doi:10.1016/j.sbspro.2014.01.1243
- Saparova, D., & Nolan, N. S. (2016). Evaluating the appropriateness of electronic information resources for learning. *Journal of the Medical Library Association*, 104(1), 24-32. doi:10.3163/1536-5050.104.1.004
- Španović, S. (2010). Pedagogical aspects of e-textbooks. *Odgovne Znanosti (Educational Sciences)*, 12(2), 459-470. Retrieved from <http://hrcak.srce.hr/file/101937>
- Štefaniková, S., & Prokop, P. (2015). Do we believe pictures more or spoken words? How specific information affects how students learn about animals. *Eurasia Journal of Mathematics, Science & Technology Education*, 11, 725-733.
doi:10.12973/eurasia.2015.1380a

- Sun, Z., & Jiang, Y. (2015). How the young generation uses digital textbooks via mobile learning terminals: Measurement of elementary school students in China. *British Journal of Educational Technology*, 46, 961-964. doi:10.1111/bjet.12299
- Topal, K., Sarikaya, Ö., Basturk, R., & Buke, A. (2015). Do students' styles of learning affect how they adapt to learning methods and to the learning environment? *Marmara Medical Journal*, 28, 81-89. doi:10.5472/MMJoa.2802.04
- Waller, R. (2012). Graphic literacies for a digital age: The survival of layout. *The Information Society*, 28, 236-252. doi:10.1080/01972243.2012.689609
- Weinstein, N., Legate, N., & Przybylski, A. K. (2013). Beauty is in the eye of the psychologically fulfilled: How need satisfying experiences shape aesthetic perceptions of spaces. *Motiv Emot*, 37, 245-260. doi:10.1007/s11031-012-9312-7
- Woody, W. D., Daniel, D. B., & Baker, C. A. (2010). E-books or textbooks: Students prefer textbooks. *Computers and Education*, 55(2010), 945-948. doi:10.1016/j.compedu.2010.04.005
- Young, K., & Luttenegger, K. (2014). Planning "lessons for everybody" in secondary classrooms. *American Secondary Education*, 43(1), 25-32.
- Zebehazy, K. T., & Wilton, A. P. (2014). Straight from the source: Perceptions of students with visual impairments about graphics use. *Journal of Visual Impairment & Blindness*, 108(4), 275-286. Retrieved from <http://www.afb.org/jvib/jvibabstractNew.asp?articleid=jvib080403>

Appendix A: Glossary of Terms

- **Graphics:** Visuals meant for storing, understanding, and communicating information and can include such items as graphs, maps, number lines, and flowcharts, among others
- **Hierarchy:** Use of size increments in text to show element importance
- **Qualitative Data:** Qualitative information derived from document analysis instruments
- **Retention:** the ability on the part of the learner to remember, recognize, and recall information presented to them
- **Spacing:** Use of white space in a document to show relationships between elements
- **Style:** Differences in typographic choices (such as changes in type size, face, color, and shape) to show emphasis, importance, and relationships between elements
- **User-Created:** The document was created by the teacher on a word processing program such as Microsoft Word or Google Docs
- **Visual:** Incorporation of an image or picture within a document's design to accompany presented information

Appendix B: Letters of Approval from Brandon Hall School



Brandon Hall School

1701 Brandon Hall Drive | Atlanta, GA 30350

March 4, 2016

Allison Feldman
1701 Brandon Hall Drive
Atlanta, GA 30350

Dear Allison,

After looking over your proposal for an Industrial Ethnography and Document Analysis of Brandon Hall School, we fully approve your study and look forward to seeing the results.

Please let me know if you need any additional assistance.

Sincerely,

A handwritten signature in cursive script, appearing to read "Johnny O. Graham".

Johnny O. Graham
Interim Head of School



Brandon Hall School

1701 Brandon Hall Drive | Atlanta, GA 30350

To Whom It May Concern:

I'm writing to acknowledge and confirm my efforts with regard to facilitating data collection from teachers in my role as Dean of Faculty at Brandon Hall School for Ms. Allison Feldman's Master's Thesis. I met with Allison in March 2016 and based on our discussions requested teachers provide educational materials for the purpose of analysis around issues of design and accessibility. It's my understanding the project was focused on document analysis using different materials from across various academic departments and designed to enhance the teaching and learning environment at Brandon Hall School. The school does not have any plans to publish the research in its current form as a thesis, although I'm currently working with Allison to schedule a time during the upcoming semester when she can present her findings to the faculty and collaborate with teachers to help them apply her research to their lesson planning and other teaching practices. Allison has also previously worked with me in her role as Director of Marketing and Communications on other projects requiring document design elements, both physical and digital, such as on-campus professional development workshop materials and digital parent communication bulletins. It was a professional honor to be able to provide support to a fellow educator and colleague in my role as Dean of Faculty and if there is any other information or assistance I can provide moving forward, please feel free to contact me.

Regards,

Justin Ryder
Dean of Faculty
Brandon Hall School
jryden@brandonhall.org

Appendix C: EDDIE Forms

Educational Document Design and Information Evaluation (EDDIE) for Supplemental Documents

Classroom: _____ Document: _____

<i>Information Design</i>	
1. Is hierarchy used to show content importance?	
2. Is style—size, face, style, color, and shape—used to show relationships with other elements?	
3. Is there any variation in typeface?	
4. Is spacing used to differentiate elements?	
5. Is the document user-created or publisher-provided?	
6. Is there ample space for student answers, if applicable?	
7. Are any visuals provided in the document?	
8. For science and mathematics courses, are any graphics included in the document?	
8a. Are any graphics three-dimensional?	
8b. Are graphics integrated in a way that would make sense to readers?	

<i>Technology Use in the Classroom</i>	
1. Is the document accessed electronically?	
2. How do students typically receive and submit the document?	
3. What type of device is most often used to access the document?	
4. Is <i>Google Apps for Education</i> used?	

<i>Cognitive Psychology</i>	
1. Could the document's length have an effect on the student's mental effort?	
2. Are there any elements of play involved?	
3. Could any external factors affect a student's use of this document?	

Educational Document Design and Information Evaluation (EDDIE) for Lesson Plans

Classroom: _____ Document: _____

<i>Lesson Planning and Pedagogical Design</i>	
1. Was a lesson plan available for analysis?	
2. How is the lesson plan created and accessed?	
3. Is the “why” of the lesson outlined?	
4. How many objectives per period are outlined?	
5. Is UDL addressed or implemented?	
6. Is PBL addressed or implemented?	

<i>Information Design</i>	
1. Is hierarchy used to show content importance?	
2. Is style—size, face, style, color, and shape—used to show relationships with other elements?	
3. Is there any variation in typeface?	
4. Is spacing used to differentiate elements?	

<i>Technology Use in the Classroom</i>	
1. Is the document accessed electronically?	
2. What type of device is most often used to access the document?	
3. Is <i>Google Apps for Education</i> used?	

Educational Document Design and Information Evaluation (EDDIE) for Adopted Textbooks

Classroom: _____ Document: _____

<i>Textbook Decisions</i>	
1. Is a textbook used in the curriculum?	
2. Is the textbook information designed in such a way that students can comprehend and understand the textbook quickly and efficiently?	
3. Does the textbook align with the age range of the course?	

<i>Implementation of Electronic Textbooks</i>	
1. Has the classroom adopted an electronic textbook?	
2. Is the book static or interactive?	
3. Are any multimedia features—narrations, pictures, maps, animations, videos, etc.—or multimedia tools—highlighting tools, messengers, search, bookmarking, etc.—included?	
4. How do students access the book?	

<i>Technology Use in the Classroom</i>	
1. Is the document accessed electronically?	
2. What type of device is most often used to access the document?	

<i>Information Design</i>	
1. Is hierarchy used to show content importance?	
2. Is style—size, face, style, color, and shape—used to show relationships with other elements?	
3. Is there any variation in typeface?	
4. Is spacing used to differentiate elements?	
5. Is the document user-created or publisher-provided?	
6. Is there ample space for student answers, if applicable?	
7. Are any visuals provided in the document?	
8. For science and mathematics courses, are any graphics included in the document?	
8a. Are any graphics three-dimensional?	
8b. Are graphics integrated in a way that would make sense to readers?	

Cognitive Psychology

1. Could the document's length have an effect on the student's mental effort?	
2. Are there any elements of play involved?	
3. Could any external factors affect a student's use of this document?	