



Title	Refinement of As-cast Austenite Microstructure in S45C Steel by Titanium Addition
Author(s)	Ohno, Munekazu; Matsuura, Kiyotaka
Citation	ISIJ International, 48(10), 1373-1379 https://doi.org/10.2355/isijinternational.48.1373
Issue Date	2008-10-15
Doc URL	http://hdl.handle.net/2115/75412
Rights	著作権は日本鉄鋼協会にある
Type	article
File Information	ISIJ International, Vol. 48 (2008), No. 10, pp. 1373-1379.pdf



[Instructions for use](#)

Refinement of As-cast Austenite Microstructure in S45C Steel by Titanium Addition

Munekazu OHNO and Kiyotaka MATSUURA

Division of Materials Science and Engineering, Graduate School of Engineering, Hokkaido University, North 13 West 8, Sapporo 060-8628 Japan.

(Received on April 2, 2008; accepted on July 14, 2008)

The effect of Ti addition on as-cast austenite (γ) structure of S45C steel has been investigated. The as-cast γ structure without the Ti addition consists of coarse columnar grains. The Ti addition leads to formation of equiaxed γ -grains and also grain refinement of the γ structure. Fully equiaxed and very fine γ -grain structure forms in a limited range of Ti addition of 0.13 to 0.17 wt%. The thermodynamic calculation of phase diagram showed that Ti carbonitride crystallizes as a primary phase in this composition range. The formation of the very fine equiaxed γ -grain structure originates from the columnar-to-equiaxed transition (CET) in δ -dendrite solidification induced by the primary Ti carbonitride particles. These particles act as the nucleation sites of the equiaxed δ -dendrite. The experimental results are suggestive of existence of finer Ti carbonitride particles retarding the grain growth of γ -phase after the peritectic transformation, which leads to the refinement of the as-cast γ structure.

KEY WORDS: carbon steel; casting; austenite; grain refinement; columnar-to-equiaxed transition; titanium carbonitride.

1. Introduction

During continuous casting of carbon steel, as-cast austenite (γ) structure consists of coarse columnar grains which often grow to several millimeters in size. The coarse γ structure causes detrimental effects to hot plastic deformation and leads to surface cracking of the cast slabs.¹⁾ It has been reported that the surface cracks propagate from the surface to the inward of the cast slabs along the grain boundaries between the columnar γ -grains.²⁾ Hence, the formation of refined and equiaxed γ -grains during the casting process is among the most important issues in steel industries.

The solidification of hyperperitectic steels, which is our main concern in this study, undergoes the crystallization of the primary ferrite (δ) phase, the formation of γ -phase through the peritectic reaction/transformation and γ solidification in L+ γ two phase field, ending up in the γ single phase. In the L+ γ two phase field, the liquid separating the grains in γ -phase retards the coarsening process of the γ -grains of which size is comparable to the δ -dendrite size.³⁻⁶⁾ Several works³⁻⁷⁾ have demonstrated that the rapid growth of γ -grains takes place immediately after the completion of the transformation into γ single phase. One of the possible ways for the refinement of γ structure is thus to inhibit such a rapid γ -grain growth by, for instance, utilizing the pinning effect of fine particles. It has been reported in the studies on the steels containing a certain amount of titanium⁸⁻¹²⁾ that the γ -grain growth is retarded by the pinning effect of fine particles such as titanium carbide, nitride or

carbonitride particles. It should be pointed out that these studies focused mainly on the γ -grain growth during the annealing operation at temperatures in the γ phase field and little has been clarified regarding the effect of titanium addition on solidification process, in particular, its effect on γ structure formed through the peritectic reaction/transformation.

In the present study, the effect of titanium addition on the as-cast γ structure in S45C steel is investigated. Our attention is directed to the variations of grain size and morphology of as-cast γ structure and, also, the correlation between the γ and δ -dendrite structures. One will see that the addition of titanium leads to the γ -grain refinement and the formation of equiaxed γ -grain simultaneously. In the next section, the experimental details are explained, followed by the results and discussion in the third section. The conclusions are given in the final section.

2. Experimental Procedures

Table 1 shows the chemical composition of the S45C steel rod with 25 mm diameter employed in this work. Our focus is placed on a range of titanium addition between 0 and 0.3 wt%. Phosphorus was also added to all the samples by 0.02 wt% to observe the δ -dendrite structure. The sample of about 250 g was put in an Al₂O₃ crucible with an inner diameter of 30 mm and a depth of 90 mm, and was melted at 1550°C in a SiC electric furnace filled with argon gas. The sample was then held for 1 h at 1550°C, followed by casting operation into a steel mold. **Figure 1** schemati-

Table 1. Chemical composition (wt%) of the S45C steel employed in the present work.

C	Si	Mn	P	S	Al	O	N
0.436	0.204	0.697	0.014	0.014	0.025	0.0015	0.0052

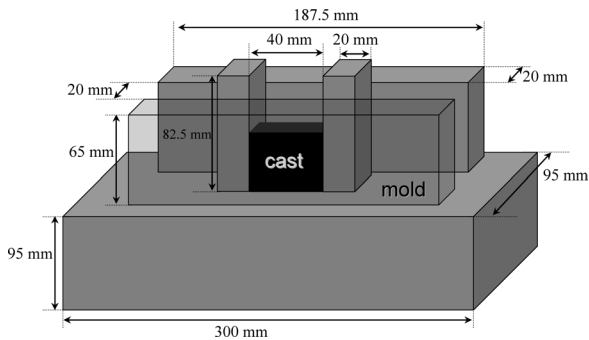
**Fig. 1.** Schematic illustration of the steel mold employed in the casting experiment.

cally represents the steel mold employed in the present experiments. The cast in the mold was cooled down to the room temperature and it was then subjected to the metallographic investigations.

The cast ingot was a rectangular prism with a thickness of 20 mm, a width of 40 mm and a height of 40 mm. The metallographic observation was performed on a horizontally sliced plane at the height of 20 mm. Both the edge regions of the width direction were excluded in the microstructural investigations. It may be then allowed to take into account only the one-dimensional heat flow in the thickness direction from the inward of the sample to the mold wall in our discussion. As demonstrated later in the next section, in fact, the columnar γ -grains and columnar δ -dendrites develop along the heat flow in the observation area. The γ -grain size was measured after polishing and etching in 3%-nital solution. The average sizes across long axis and short axis of columnar γ -grains and the average size of equiaxed γ -grains were determined by graphical analysis of the optical microscope image. The δ -dendrite structure was also investigated after etching in Oberhoffer's solution. The primary and secondary dendrite arm spacing and the center-to-center spacing of equiaxed dendrites were determined by the microstructural observation. The fine inclusion particles were examined by means of Scanning Electron Microscope (SEM) and were analyzed by Electron Probe Micro-Analyzer (EPMA).

3. Results and Discussion

The γ structure in the sample without titanium addition is shown in **Fig. 2(a)**. It is to be noted that the columnar γ grains develop from the surface to the inward of the ingot, which should be in accordance with the opposite direction of heat flow in the present casting condition. The equiaxed γ -grains form in the center region of the ingot. The former microstructure, *i.e.*, δ -dendrite structure is demonstrated in **Fig. 2(b)**. The columnar dendrites develop from the surface to the inward of the ingot, while the equiaxed dendrites are observed in the central region of the ingot. The cooling rate in the present experiment can be estimated based on the empirical relation,¹³⁾ $\lambda_2 = 683(60\dot{T})^{-0.37}$, between the cool-

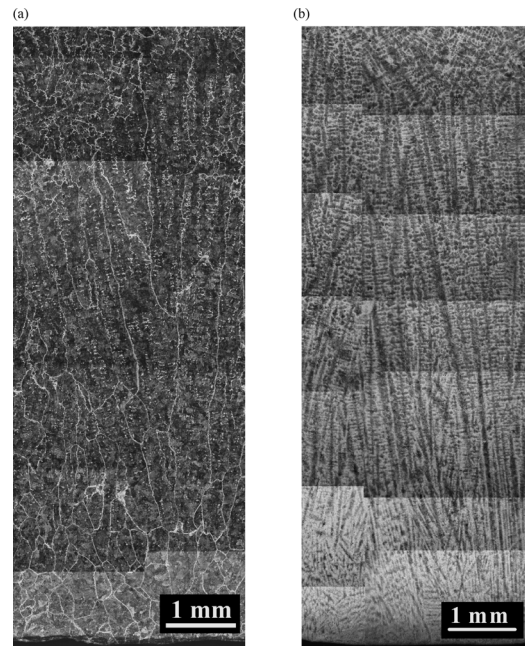
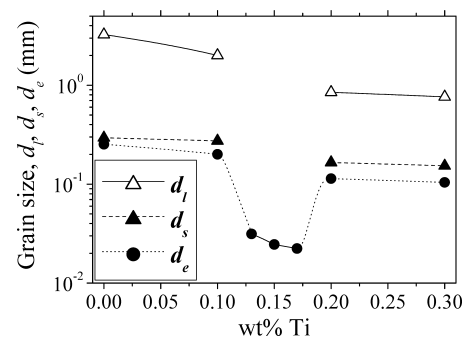
**Fig. 2.** Optical micrographs on the transverse section showing (a) γ -grain and (b) δ -dendrite structures in as-cast sample without titanium addition. The top and the bottom of each micrograph correspond to the center and the surface of the ingot, respectively.**Fig. 3.** Effect of Ti addition on γ grain sizes. d_l is γ -grain size across long axis and d_s is γ -grain size across short axis in the columnar region, while d_e denotes the equiaxed grain size.

ing rate, \dot{T} (K/s), and Secondary Dendrite Arm Spacing (SDAS), λ_2 (μm). The SDAS at 5 mm inward from the surface, for example, was measured to be approximately 60 μm . This value yields $\dot{T} = 12$ K/s which falls within the range of cooling rates often estimated for the thin slab continuous casting processes of carbon steels.⁷⁾

The effect of titanium addition on the γ -grain size is demonstrated in **Fig. 3**. d_l and d_s represent the average sizes of long and short axes of the columnar γ -grains, respectively. d_e indicates the average size of the equiaxed γ -grains observed in the central region of the sample. The values of columnar grain sizes, d_l and d_s are missing in the range of titanium addition of 0.13 to 0.17 wt%, since the γ structure consists of only the equiaxed grains over the entire thick-

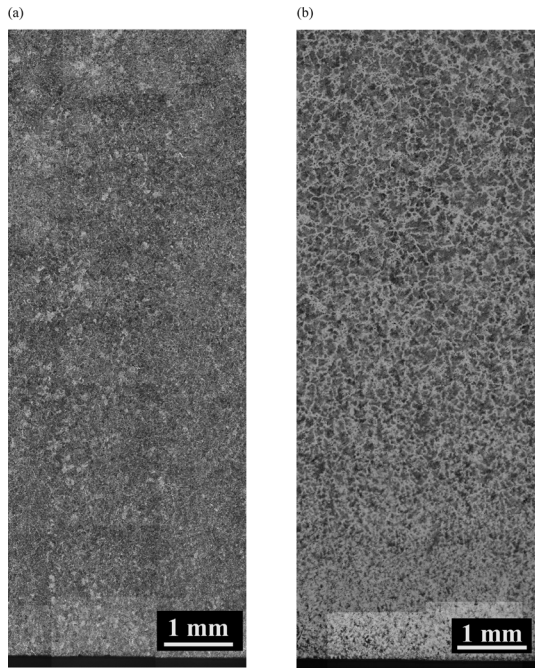

Fig. 4. Optical micrographs on the transverse section showing (a) γ -grain and (b) δ -dendrite structures in as-cast sample with addition of 0.15 wt% Ti. The top and the bottom of the each micrograph correspond to the center and the surface of the ingot, respectively.

ness of the ingot. It should be noticed that the sharp drop of d_e occurs in the range of titanium addition between 0.13 and 0.17 wt%. As shown in Fig. 2(a), the microstructure without titanium addition exhibits a relatively coarse γ structure characterized by $d_l=3.25$ mm, $d_s=0.29$ mm, $d_e=0.25$ mm. Such a coarse structure does not substantially change with the addition of 0.1 wt% Ti. However, the addition of 0.13 wt% Ti leads to a significant refinement of γ -grains. Fully equiaxed grain structures were observed up to 0.17 wt% Ti where the grain size takes a minimum value, $d_e=22$ μ m. The γ -grain structure and δ -dendrite structure in the sample with 0.15 wt% Ti are shown in Figs. 4(a) and 4(b), respectively. Compared with the microstructures in Fig. 2, there are remarkable differences in both the γ -grain and δ -dendrite structures. Shown in Fig. 5 is the enlargement of the γ structure in the sample with 0.15 wt% Ti. The bottom of the micrograph corresponds to the surface of the ingot. It is seen that the fine equiaxed γ grains form even in the vicinity of the surface. As indicated in Fig. 3, however, the further addition of titanium results in the formation of coarse γ structure. The columnar γ -grains again develop from the surface by adding more than 0.2 wt% Ti. The δ -dendrite structure shown in Fig. 4(b) exhibits fully equiaxed structure, which is in marked contrast to the columnar dendrite structure shown in Fig. 2(b). The dependence of the δ -dendrite structure on the titanium addition will be discussed later in more detail. It should be stressed that both the remarkable grain refinement and the formation of fully equiaxed grains simultaneously take place in the range of titanium addition of 0.13 to 0.17 wt%.

To understand this dependence of the γ structure on the titanium addition, the phase equilibria of the present system were analyzed based on the CALPHAD approach.¹⁴⁾ Our focus is placed on the Fe–C–Ti–N quaternary system, since

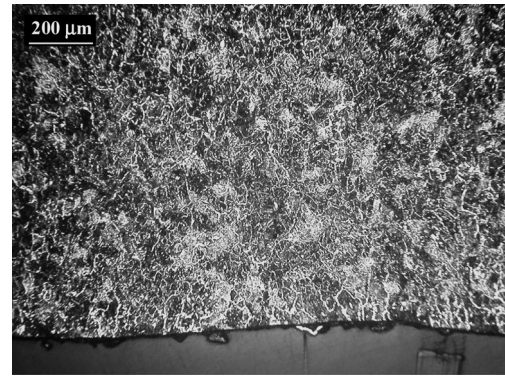

Fig. 5. Enlargement of γ -austenite structure in as-cast sample with addition of 0.15 wt% Ti. The bottom of micrograph corresponds to the surface of the ingot.

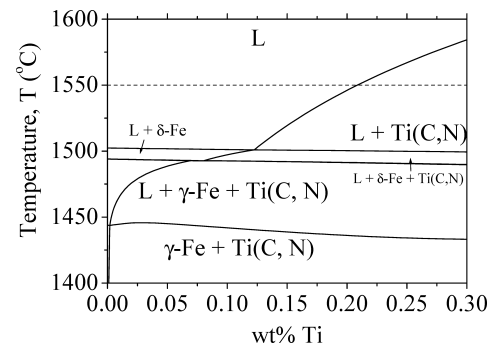

Fig. 6. Calculated phase diagram of Fe–0.435wt%C–0.0052 wt%N–Ti system based on the thermodynamic assessment reported by Lee.¹⁵⁾ The dashed line represents the holding temperature, 1550°C, before the casting operation.

the preliminary calculations showed that the other elements such as Mn, Si and Al do not alter the phase diagram substantially. In this work, we employed the thermodynamic database reported by Lee.¹⁵⁾ Figure 6 shows the calculated phase diagram of Fe–0.435wt%C–0.0052wt%N–Ti. The dashed line denotes the holding temperature of the liquid steel sample before casting, 1550°C. The titanium carbonitride is specified as Ti(C, N). It is firstly noted in this phase diagram that the addition of titanium is almost irrelevant to the melting temperatures of δ -Fe and γ -Fe. Importantly, the Ti(C, N) is stabilized at higher temperatures by increasing titanium concentration. The primary crystal is Ti(C, N) at more than 0.12 wt% Ti. As mentioned above, the fine equiaxed γ -grains were observed over the whole thickness of ingot with 0.13–0.17 wt% Ti. It is then strongly speculated that the formation of fine equiaxed γ -grains be closely associated with the primary Ti(C, N). The SEM image of the sample with 0.15 wt% Ti is shown in Fig. 7(a). The enlargement of the particle is given in Fig. 7(b). The particle has a faceted shape with an edge length of about 2 μ m. This is a typical shape of the primary Ti(C, N) as reported in the early work.¹⁶⁾ This faceted particles, in fact, were confirmed to be Ti(C, N) by means of the EPMA analysis. These faceted Ti(C, N) particles are uniformly dispersed over the whole thickness of ingot with 0.13–0.17 wt% Ti. In the samples with 0.2 and 0.3 wt% Ti, also, the faceted particles of Ti(C, N) existed but thinly scattered.

It has been reported that the titanium carbide and nitride

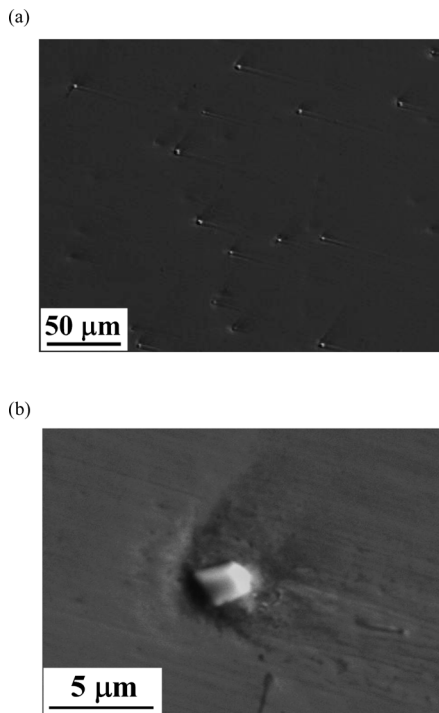

Fig. 7. (a) SEM image of Ti(C,N) particles in as-cast sample with addition of 0.15 wt% Ti. (b) Enlargement of Ti(C,N) particle with faceted shape.

are very effective in promoting heterogeneous nucleation of δ -Fe, because of low disregistry between the titanium carbide/nitride and δ -Fe.¹⁷⁾ The supercooling degree for the nucleation of δ -Fe on TiN and TiC was measured to be no more than 1.8 K.¹⁷⁾ This small degree indicates a high ability of Ti(C,N) particle acting as a heterogeneous nucleation site for δ -Fe. In the studies on ferritic stainless steels,^{16,18)} moreover, it has been revealed that the Ti(C,N) particles in the melt give rise to the Columnar-to-Equiaxed Transition (CET) of δ solidification. These facts suggest that the CET for δ -dendrite takes place prior to the formation of equiaxed γ structure with the addition of 0.13–0.17 wt% Ti. In fact, the fully equiaxed dendrite structure appears in the sample with 0.15 wt% Ti as shown in Fig. 4(b). In order to further address this point, the correlation between γ -grain and δ -dendrite structures will be scrutinized as detailed below.

We firstly focus on the formation depth of columnar region in the γ -grain and δ -dendrite structures. In the present study, the formation depth of columnar γ -grains is characterized as $L_\gamma = l_{c\gamma}/l \times 100$ (%) where $l_{c\gamma}$ represents the length of the columnar grain region measured across thickness on the transverse section of the sample ingot and l is the half of the thickness, *viz.*, $l = 10$ mm. The measured formation depth of the columnar γ -grain region is represented by dashed line with open squares in Fig. 8. In the sample without titanium, the columnar γ -grain region covers the large part of the sample, more than 70%. The formation depth then slightly decreases by addition of 0.1 wt% Ti. The abrupt decrease of the depth down to 0% is observed between 0.1 and 0.13 wt% Ti, which indicates that the equiaxed γ -grains form over the whole thickness of the ingot as already discussed in Fig. 3. The formation depth then increases to about 30% with the titanium addition of

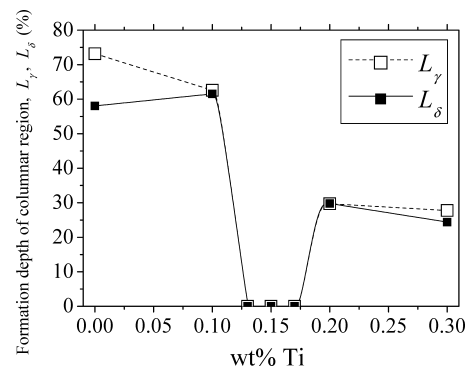

Fig. 8. Effect of Ti addition on formation depth of γ (L_γ) and δ (L_δ) columnar regions.

more than 0.2 wt%. Also, we measured the formation depth of columnar dendrite region, $L_\delta = l_{c\delta}/l \times 100$ (%), where $l_{c\delta}$ represents the length of the columnar dendrite region measured from the surface to the inward along the thickness direction on the transverse section of the sample ingot. The value of L_δ is indicated by solid line with full squares in Fig. 8. There exist a strong correlation between L_γ and L_δ . The fully equiaxed dendrite structure develops in the sample with 0.13–0.17 wt% Ti where the crystallization of the Ti(C,N) occurs prior to δ solidification. Hence, the primary Ti(C,N) probably gives rise to the CET of δ solidification in the present system. Ahead of the solidification front of the columnar dendrite, there is constitutional undercooling region for the δ solidification. The small particle of Ti(C,N) crystallizing from the melt comes in such a region. Then, the δ -Fe nucleates on the Ti(C,N) particle because of its low disregistry and it grows to the equiaxed dendrite, preventing the further development of columnar dendrite. It is seen in Fig. 8 that the columnar dendrite again develops by adding more than 0.2 wt% Ti. According to the phase diagram given in Fig. 6, the Ti(C,N) particles already exist in the melt during the holding operation at 1550°C, when more than 0.2 wt% Ti is added. In this case, the coarsening and/or coalescence of such particles may occur in the melt and the number of Ti(C,N) particles coming in the constitutional undercooling region for δ -dendrite, that is, the number of heterogeneous nucleation sites for δ -Fe dendrite decreases during the casting. This results in the development of the columnar dendrite structure in the samples with the titanium addition of more than 0.2 wt%.

It is evident from Fig. 8 that the formation depth of the columnar γ -grain region is strongly correlated with that of the columnar δ -dendrite region. From this comparison, the formation of equiaxed γ -grains probably originates from the formation of the equiaxed δ -dendrite structures. It has been reported that the development of columnar γ -grains is essentially attributable to the steep temperature gradient at $\delta \rightarrow \gamma$ transformation front.¹⁹⁾ The formation of the equiaxed γ -grains requires the temperature gradient at $\delta \rightarrow \gamma$ transformation front to be less than 2.5 K/mm.¹⁹⁾ Note that the temporal and spatial changes of temperature during the γ -grain growth should be entirely dependent on the details of δ -dendrite solidification process, because the heat generation due to the latent heat of solidification affects the temperature gradient at the subsequent $\delta \rightarrow \gamma$ transformation front, and the solid fraction at the transformation tempera-

ture that determines the amount of heat generation depends on the composition of the steel. Without an effective nucleation agent, the solidification of δ -Fe involves a relatively large undercooling and the columnar dendrite develops under a steep temperature gradient. When the subsequent $\delta \rightarrow \gamma$ transformation front undergoes such a steep temperature gradient, the columnar γ -grains will form because the γ -grains nucleate near the mold wall and keep growing inward along this steep temperature gradient. However, when there exists the effective nucleation agent such as Ti(C,N) where the undercooling for δ -Fe is 1.8 K,¹⁷⁾ the solidification of δ -dendrite can proceed with small undercooling, resulting in the formation of equiaxed δ -dendrite structure. Compared with the continuous growth of columnar dendrite from the mold wall, the formation of equiaxed dendrite in the melt is spatially discontinuous. Ahead of the δ/L dendrite front, the latent heat is released by the formation of new equiaxed dendrite and, therefore, the heat generation is also spatially discontinuous. This irregular temperature change during δ solidification process may reduce the temperature gradient at the $\delta \rightarrow \gamma$ transformation front and result in the equiaxed γ -grain structure. The quantitative discussion on this point needs the accurate temperature measurements during the casting process and also the detailed heat transfer analysis on the present system, which remain as a future work. The additional or other possibility for the formation mechanism of equiaxed γ -grain could be related to the pinning effect of Ti(C,N) particles. In the following, the pinning effect of Ti(C,N) is discussed in the light of the correlation between the γ -grain and δ -dendrite structures.

Figure 9(a) represents the variation of the short axis length of columnar γ -grains, d_s , and the primary arm spacing of columnar dendrites, λ_1 , with respect to the titanium addition. Note that the values of d_s and λ_1 are lacking in the range of 0.13–0.17 wt% Ti, since the columnar structures were not observed in the samples with these titanium concentrations. The primary arm spacing monotonically decreases with increasing titanium addition, which is consistent with the early experimental finding.²⁰⁾ The short axis length of columnar γ -grains also monotonically decreases with the titanium addition, except for the samples with 0.13–0.17 wt% Ti. As mentioned in the introduction, the present hyperperitectic steel undergoes γ solidification after the peritectic transformation. During the γ solidification, the liquid separating the γ phases retards the coarsening process of the γ -phase of which size is comparable to the size of the δ dendrite structure. The segregation of solute elements occurs in the residual liquid between the columnar grains where the formation of Ti(C,N) is likely to take place. In fact, the Ti(C,N) particles are observed in the inter-dendritic region in the samples with 0.1, 0.2 and 0.3 wt% Ti. These particles in the inter-dendritic region can pin the γ -grain boundary migration so that the short axis length of the columnar γ -grain decreases with a decrease of the primary arm spacing of the columnar dendrite, as shown in Fig. 9(a).

Figure 9(b) demonstrates the variation of the equiaxed γ -grain size, d_e , and the center-to-center spacing of equiaxed δ -dendrites, λ_e , with respect to the titanium addition. It should be noted that the spacing of equiaxed dendrites does

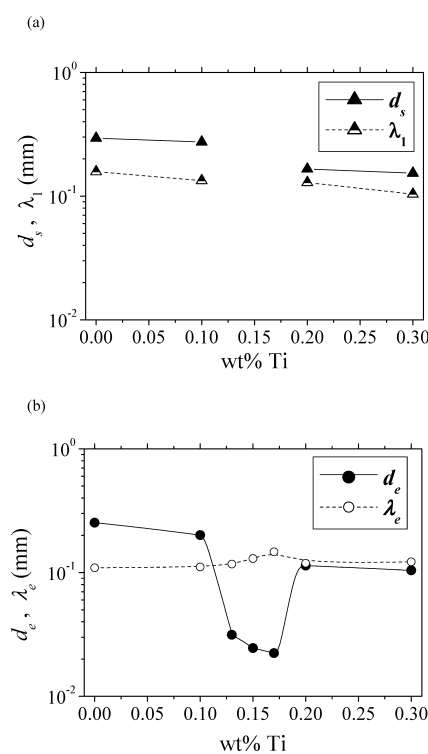

Fig. 9. (a) Dependence of columnar γ -grain size across short axis, d_s , and primary arm spacing of columnar δ -dendrites, λ_1 , on titanium addition. (b) Dependence of equiaxed γ -grain size, d_e , and center-to-center spacing of equiaxed δ -dendrites, λ_e , on titanium addition.

not change considerably with the titanium addition. The equiaxed γ -grains are larger than the spacing of equiaxed dendrites in the samples without titanium and with 0.1 wt% Ti. However, the addition of more than 0.13 wt% Ti decreases the equiaxed γ -grain size down to the size less than the spacing of equiaxed dendrites. The equiaxed γ structure in the sample with 0.15 wt% Ti is shown in **Fig. 10(a)**. The equiaxed δ -dendrite structure in the same region is superimposed on the micrograph of the γ structure in **Fig. 10(b)**. The dark and transparent areas represent the equiaxed δ -dendrite structure. One can readily realize that the γ -grain size is smaller than the equiaxed δ -dendrite size. It has been well known that the Ti(C,N) particle is quite effective as the pinning particle for the γ grain growth.^{8–12)} In the present experiment, the γ -grain growth should be retarded by the pinning effect of Ti(C,N) particles. Importantly, the fact that d_e is less than λ_e suggests that the pinning particles should exist in the δ -dendrite prior to the formation of γ -phase. As mentioned above, the faceted particles with the edge length of 2 μm are uniformly dispersed in the samples with 0.13–0.17 wt% Ti. The average distance between these particles is about 50 μm . This value is too large to explain the refined γ -grain sizes of about 20–30 μm observed in the samples with 0.13–0.17 wt% Ti. The volume fractions of these faceted Ti(C,N) particles are estimated to be 7.4×10^{-5} , 5.5×10^{-5} and 8.9×10^{-5} in the samples with 0.13, 0.15 and 0.17 wt% Ti, respectively. **Figure 11** shows the calculated volume fraction of Ti(C,N), $f_{\text{Ti(C,N)}}$, assuming the equilibrium solidification processes. Three horizontal lines represent the above-mentioned estimated values of the faceted Ti(C,N) particles in each sample. The peritectic

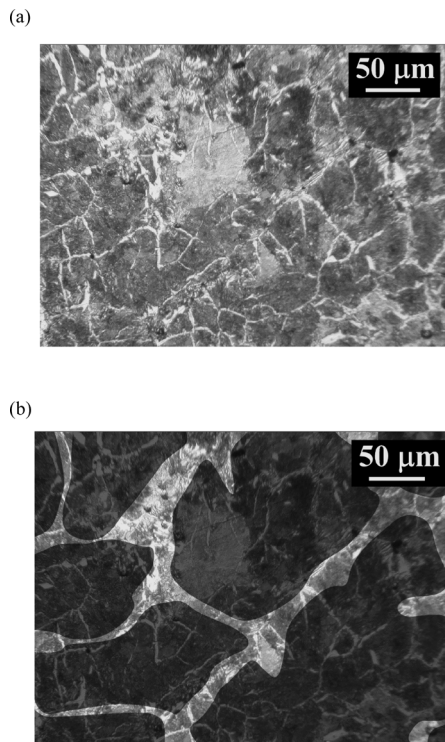

Fig. 10. (a) Equiaxed γ structure in as-cast sample with 0.15 wt% Ti. (b) Equiaxed γ and δ structures in as-cast sample with 0.15 wt% Ti. Equiaxed δ -dendrite structure is superimposed on γ structure shown in (a).

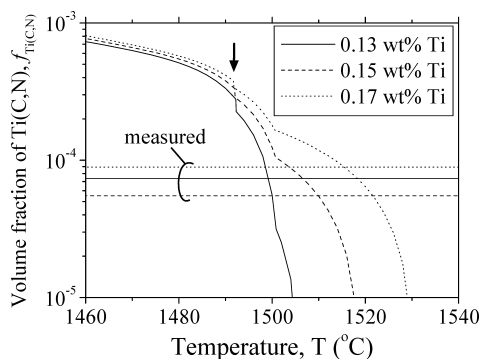

Fig. 11. Calculated volume fractions of Ti(C,N) during equilibrium solidifications. Three horizontal lines represent measured volume fractions of faceted Ti(C,N) particles. The peritectic reaction temperature is indicated by the arrow.

reaction temperature, T_p , is indicated by the arrow. The volume fractions of Ti(C,N) just above T_p are calculated to be about $2.0\text{--}3.0 \times 10^{-4}$ in these compositions and these values are larger than the measured volume fractions of the faceted particles. Hence, the observed faceted particles of Ti(C,N) may not represent all the Ti(C,N) particles in the samples. It is highly possible that there exist finer particles of Ti(C,N) which are not detectable in the resolution of the present microstructural observations. The γ -grain refinement in the range of 0.13 to 0.17 wt% Ti can probably be ascribed to the pinning effect due to such finer Ti(C,N) particles. It has been reported that the pinning effect of Ti(C,N) on the γ -grain growth process can be described by Zener equation, $d_\gamma = \beta \cdot d_p / f_{\text{Ti(C,N)}}$, where d_γ is the γ grain size, d_p is the particle diameter of Ti(C,N) and β is given as

0.17 .²¹⁾ Provided that $f_{\text{Ti(C,N)}}$ of the unobservable finer particles corresponds to the difference between the volume fraction of observed faceted particle and total volume fraction at T_p , we can estimate the particle diameter of the finer Ti(C,N) particles to be 32–46 nm by the Zener equation. Although we cannot discuss the validity of this estimation, it is very likely that the γ -grain refinement is ascribable to the pinning effect of fine Ti(C,N) particles which are not detectable in this study.

As already mentioned, when more than 0.2 wt% Ti is added, the primary Ti(C,N) particles initially exist in the melt and they grow during the holding operation at 1550°C. The growth continues during the cooling. In these samples, therefore, the number of fine particles of Ti(C,N) should decrease, making the grain refinement less effective, which is exactly what we observe in Fig. 9(b).

Finally, it would be worthwhile to emphasize the following point. As mentioned, under a steep temperature gradient, γ -grains nucleate near the mold wall and keep growing inward along the steep temperature gradient to develop the columnar γ -grain structure. On the other hand, the fact shown in Fig. 9(b) that the γ -grain size is smaller than the equiaxed δ -dendrite size means that there are many nucleation sites of γ -phase in δ -dendrites. The nucleation of γ -phase at many sites leads to the development of equiaxed γ -grain structure, which occurs under a mild temperature gradient. The author's research group has recently found that fine equiaxed γ -grain structure develops even in coarse columnar δ -dendrite structure,²²⁾ which indicates that columnar/equiaxed selection in γ -grain structure does not depend on columnar/equiaxed variation in δ -dendrite structure, namely, the morphology of δ -dendrite structure. This fact is indicative of that the columnar/equiaxed selection in γ -grain structure is largely dependent on the temperature gradient at the δ to γ transformation front.

4. Conclusions

Casting experiments of S45C steel were performed, focusing on the effect of titanium addition on the as-cast γ structure. The following results obtained in this work are important to be summarized,

(1) Without the titanium addition, the γ structure consists of relatively coarse columnar grains. The addition of titanium in the range of 0.13 to 0.17 wt% leads to the formation of the fine equiaxed γ grains over the whole thickness of ingot. The further addition of titanium causes the reformation of the coarse columnar γ -grains.

(2) There is a strong correlation between the formation depths of columnar γ -grain and δ -dendrite structures. In the range of 0.13 to 0.17 wt% Ti, prior to the formation of equiaxed γ structure, the Columnar-to-Equiaxed Transition (CET) of δ -dendrite structure takes place due to the primary crystal of Ti(C,N). In the sample with more than 0.2 wt% Ti, the crystallization and coarsening of the primary Ti(C,N) particles occur during the holding operation at 1550°C and the columnar dendrite structure again develops.

(3) The titanium addition leads to the grain refinement effect of γ structure. The remarkable refinement effect appears in the range of 0.13 to 0.17 wt% Ti where the fully

equiaxed γ -grain develops over the whole thickness of ingot. The as-cast γ -grain size decreases down to a size less than the equiaxed δ dendrite size.

REFERENCES

- 1) Y. Maehara, K. Yasumoto, Y. Sugitani and K. Gunji: *Tetsu-to-Hagané*, **71** (1985), 1534.
- 2) L. Schmidt and A. Josefsson: *Scand. J. Metall.*, **3** (1974), 193.
- 3) K. Yasumoto, T. Nagamichi, Y. Maehara and K. Gunji: *Tetsu-to-Hagané*, **73** (1987), 1738.
- 4) N. S. Pottore, C. I. Garcia and A. J. DeArdo: *Metall. Trans. A*, **22A** (1991), 1871.
- 5) T. Maruyama, K. Matsuura, M. Kudoh and Y. Itoh: *Tetsu-to-Hagané*, **85** (1999), 585.
- 6) T. Maruyama, M. Kudoh and Y. Itoh: *Tetsu-to-Hagané*, **86** (2000), 86.
- 7) N. Yoshida, Y. Kobayashi and K. Nagai: *Tetsu-to-Hagané*, **90** (2004), 198.
- 8) A. Adachi, K. Mizukawa and K. Kanda: *Tetsu-to-Hagané*, **49** (1963), 894.
- 9) S. Matsuda and N. Okumura: *Tetsu-to-Hagané*, **62** (1976), 1209.
- 10) H. Kobayashi and Y. Kasamatu: *Tetsu-to-Hagané*, **67** (1981), 1990.
- 11) B. Feng, T. Chandra and D. P. Dunne: *Mater. Forum*, **13** (1989), 139.
- 12) S. F. Medina, M. Chapa, P. Valles, A. Quispe and M. I. Vega: *ISIJ Int.*, **39** (1999), 930.
- 13) A. Suzuki, T. Suzuki, Y. Nagaoka and Y. Iwata: *J. Jpn. Inst. Met.*, **32** (1968), 1301.
- 14) L. Kaufman and H. Bernstein: *Computer Calculation of Phase Diagrams with Special Reference to Refractory Materials*, Academic Press, New York, (1970), 1.
- 15) B. J. Lee: *Metall. Mater. Trans. A*, **32A** (2001), 2423.
- 16) T. Koseki and H. Inoue: *J. Jpn. Inst. Met.*, **65** (2001), 644.
- 17) B. L. Bramfitt: *Metall. Mater. Trans.*, **1** (1970), 1987.
- 18) Y. Itoh, S. Takao, T. Okajima and K. Tashiro: *Tetsu-to-Hagané*, **66** (1980), 710.
- 19) K. Matsuura, Y. Itoh and K. Matsubara: *Tetsu-to-Hagané*, **76** (1990), 714.
- 20) K. Isobe, M. Kusano and K. Hirabayashi: *CAMP-ISIJ*, **10** (1997), 973.
- 21) P. A. Manohar, M. Ferry and T. Chandra: *ISIJ Int.*, **38** (1998), 913.
- 22) M. Sasaki, K. K. Ohsasa, M. Kudoh and K. Matsuura: *ISIJ Int.*, **48** (2008), 340.