



XXXVII IBERIAN LATIN AMERICAN CONGRESS
ON COMPUTATIONAL METHODS IN ENGINEERING
BRASÍLIA - DF - BRAZIL

DESIGN AND IMPLEMENTATION OF A RESONANT WIRELESS POWER TRANSMISSION SYSTEM BASED ON A SELF OSCILLATING D.C-A.C CONVERTER

Hans Hoffmann Sathler

hanshs@ufmg.br

Pedro Donoso Garcia

pedro@cpdee.ufmg.br

Graduate Program in Electrical Engineering - Federal University of Minas Gerais - Av. Antônio Carlos 6627, 31270-901, Belo Horizonte, MG, Brazil.

Ulisses Fabrini Barbosa

ulissesfabrini@gmail.com

Felipe de Oliveira Silva Zanon

felipeos.zanon@gmail.com

Úrsula do Carmo Resende

resendeursula@gmail.com

Departamento de Engenharia Elétrica, CEFET –MG

Avenida. Amazonas 7675- CEP 30510-000- Belo Horizonte - MG - Brasil

Abstract. *In the present work a complete wireless power system, composed by two identical units (Transmitter and Receiver) and a Power Electronic Converter (PEC), was designed and built. Receiver unit is constituted of two wire coils, drive coil (DC) and main coil (MC), while transmitter unit have only a MC. In transmitter unit the MC is connected to the PEC. In the receiver unit the DC is connected to a load of $1k\Omega$ and inductively coupled to the MC. DC has one turn and MC ten turns with $8.3894 \mu H$. As the natural capacitance of each MC is very small, a capacitor was solder in parallel with each MC to reduce the resonant frequency to about 1.3MHz. The PEC is a self-oscillating DC-AC power converter projected to work in the range from 800kHz to 3MHz.*

Keywords: *Wireless Power Transmission, Self-Oscillating Converter, Inductive Coupling*

1 INTRODUCTION

The concept of wireless power transmission (WPT) started with Nikola Tesla at the end of XIX century. However, research about this kind of transmission has received more attention in the past few years with the advances of areas such as communication, medicine, robotics, military and others.

The main techniques used in WPT studies are the Inductive Coupling Method (IC), the Microwaves Method (MW) and the Resonant Inductive Coupling Method (RIC). The IC is a very highly developed technology and it is used in large scale in all fields of the electrical engineering, for example, the transformers operation principle, which works according to Faraday's Law. The second one, the MW method, also is a consolidated kind of wireless transmission and its operation is based on the use of antennas able to transmit and receive active power to feed a load as in the work from W. C. Brown (1984). The third method, the RIC, is a technology proposed in 2007 by researchers of Massachusetts Institute of Technology. This method uses coils, or a set of coils, magnetically coupled and operating in resonance to achieve high efficiency. It was demonstrated that is possible to carry significant amounts of active power over larger distances using resonant coils as seen in the work of A. Kurs (2007). Since then, many other works have been developed, using and extending this technology to energy supply different kind of loads presented by W. Wey et al. (2014) and O. Jonah (2013). Currently, the main challenges of technology are to increase the efficiency and transmission distance and to design compact systems to supply different kind of loads.

The RIC method was chosen to be investigated this work. A complete wireless power system, composed by two identical coils (transmitter and receiver) and a self-oscillating power electronic converter (PEC), was designed and built. The work is divided in five more topics, in topic two the entire WPT system schematics is presented. The power electronic converter is presented and discussed in the topic three. In addition, the coils project are presented in topic four, the experimental results and conclusions are shown in topics five and six, respectively.

2 WPT DESCRIPTION

The complete WPT system investigated in this work is illustrated in Figure 1. The system is composed by two identical coils, transmitter main coil (TMC) and receive main coil (RMC). The load is connected to a receive drive coil (RDC) which is inductively coupled to the RMC. The TMC is connected to a self-oscillating DC-AC PEC projected to work in the range from 0.8 MHz to 3 MHz. The PEC is powered by a 24 VDC power supply.

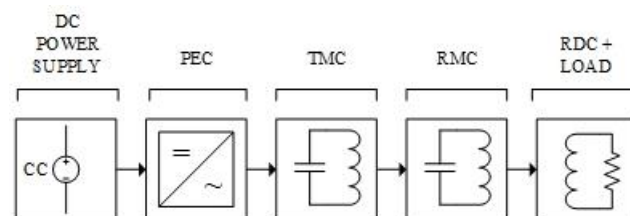

Figure 1. WPT System

The DC power supply feeds the PEC which transforms the DC input current into an AC output current, which is necessary to make possible the transmission of energy, since the WPT system works according to Faraday's Law. Since the natural capacitance of the each main coil is very small, it is necessary to include an external capacitor, connected in parallel, in order to reduce the resonant frequency. As the TMC is directly connected to the PEC, it acts like a LC filter, transforming the square-wave into a sinusoidal-wave.

The power transfered between TMC and RMC is due to the number of magnetic flux lines generated by TMC that are concatenated by RMC, ie, the magnetic coupling between TMC and RMC. So, the power transmission efficiency is directly related with the distance between TMC and RMC, since smaller distances lead to a greater number of lines that ties RMC, a greater current is induced. To achieve the maximum efficiency, the main coils must be projected to operate in the same resonant frequency (Bonifácio, 2009), that is, their impedance is purely resistive.

The transmitter unit (TU) is composed by the PEC and by the TMC. The receiver unit (RU) is composed by RMC and RDC, which consists of a cooper single loop wire coil. RMC and RDC does not operate in resonance, but as they are built close to each other, both coil are magnetically coupled. The use of RDC avoids connecting the load directly to the RMC. So, as the RMC impedance is not altered, the WPT resonance frequency is also kept constant and the efficient system operation is secured (Wenzhen, 2008).

3 PEC'S PROJECT

The circuit of self-oscillating power electronic converter designed and built in this work is illustrated in Figure 2. It is composed by two N-channel enhancement power MOSFETs (Q1 and Q2), two chokes coils (L1 and L2), two fast diodes (D1 and D2) providing cross coupled feedback and two bias resistors (R1 and R2). The circuit is directly connected to TMC.

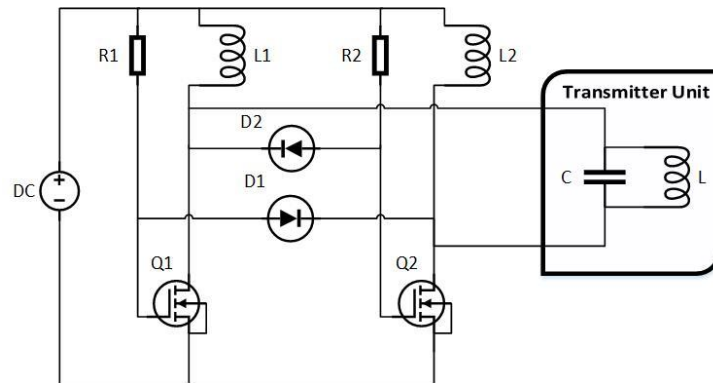

Figure 2. Self- Oscillating PEC circuit

The circuit illustrated in Figure 2 is a self-oscillating converter, whose oscillation frequency matches the TMC resonance frequency given by Eq.(1).

$$f = \frac{1}{2\pi\sqrt{LC}} \quad (1)$$

MOSFETs Q1 and Q2 operate in opposite way, so, when Q1 is on, Q2 is turned off. This operating mode is possible because high impedance elements (L1 and L2) are connected to both drain terminals of MOSFETs. However, it is not possible to declare that the circuit only have two operations states (Q1ON – Q2OFF and Q2ON – Q1OFF), because diodes operation inserts a non-linearity in system dynamics. As the work focus is on WPT, PEC operation details are not discussed.

The inductance values of the coils L1 and L2 were set empirically. The adjustment considers that L1 and L2 impedance values should be, at least, ten times higher than the impedance of TMC. It is necessary that the time to discharge the gate capacitance of the MOSFETs be lower than a half-period of resonant frequency to guarantee the oscillation frequency set by TMC. This discharge time is directly related to RC time constant composed by the bias resistors values and gates capacitances. So, the bias resistors values were adjusted to achieve the designed operation condition.

Components used in the PEC developed in this work are presented in Table 1. The TMC e RMC inductance and resistance are, respectively, $L = 8.38\mu\text{H}$ and $R = 83.28\text{ m}\Omega$. The value of parallel connected external capacitors 4nF, that leads to a resonance frequency of 0.869 MHz. Parameters Rs1 and Rs2 correspond to L1 and L2 resistance.

Table 1. PEC circuit parameters and components

Component/Parameter	Value
R1	330 Ω
R2	330 Ω
L1 / Rs1	48.38 μH / 1.31 Ω
L2 / Rs2	48.25 μH / 1.31 Ω
C	4 nF
L / R	8.38 μH / 83.28 m Ω
D1	1N4148
D1	1N4148
Q1	IRF540
Q2	IRF540

PEC described in Figure 2 was simulated using LT Spice IV. All values were adjusted according to the measured data and the spice model of the semiconductors devices. The current obtained in the TMC coil is presented in Figure 3. It is possible to observe that the sinusoidal characteristic of the current it was found for oscillation frequency equal to 870 kHz.

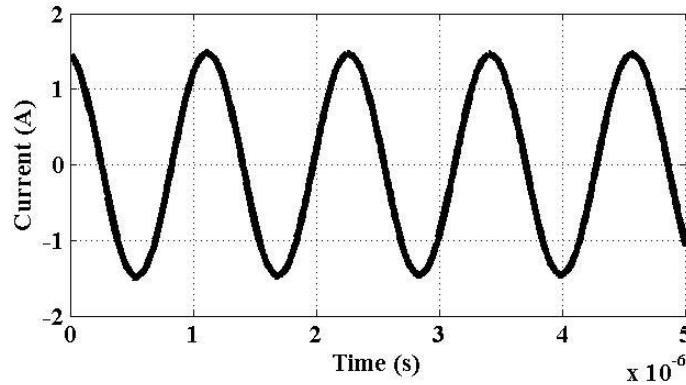

Figure 3. Transmitter Unit current

The self-oscillating topology is a very interesting type of converter and there are many benefits in its use. All components are easy to find or build, which is the case of L1, L2 and TMC. When compared to other types of converters, the biasing of mosfets is easier because is not required the use of microcontrollers or drivers devices, only biasing resistors. The establishment of the operation frequency is another advantage of the self-oscillating PEC, that is, the switching frequency is set by TMC according to Eq.(1).

The disadvantages of the self-oscillating PEC start to appear when the operation frequency exceeds 0.8 MHz. Above this frequency, mosfets conduction resistance and gate capacitance lead to significant switching losses. Due to the RC time constant, with the increase of the operation frequency, the value of bias resistors should be reduced that leads to more energy spend by joule effect on these resistors. Since the PEC operates in high frequency, it is necessary cooling appropriately the mosfets to transmit more power to the load. If the transistors are not properly cooled, the current and voltage are significantly attenuated.

4 COILS PROJECT

The complete design of a WPT system requires that the coil parameters R, L and C (self-inductance, intrinsic resistance and parasitic-capacitance, respectively) are cautiously determined. So, in this section a mathematical methodology to determinate these parameters is presented and validated by measurements.

The coils used in WPT system proposed are made by copper wire, which has an intrinsic resistance. This resistance is composed by two components: radiation losses (R_r) and joule losses (R_Ω). The frequency range used (0.8 MHz to 1.3 MHz) allow to define R_r as Eq.(2) (Balanis, 2005).

$$R_r = \frac{nr}{a} \sqrt{\frac{\mu\omega}{2\sigma}}, \quad (2)$$

where μ is free-space permeability, a is the wire radius, r is the turn radius, n is the number of turns, l is wire length, ε is free-space dielectric constant, h is coil length, c is the light speed and ω is angular frequency. To frequencies in magnitude order of MHz, R_Ω can be disregarded.

To determine self-inductance of the coils, Maxwell Method was used (Maxwell, 2002). This method considers mutual inductance between coil turns in a solenoid. Basically the mutual inductance is calculated between two current differential filaments using the Neumann Eq.(3) (Queiroz, 2003).

$$M = \frac{\mu}{4\pi} \iint \frac{\cos \varepsilon}{r} ds ds', \quad (3)$$

where ds and ds' are current differential filaments of two different turns, ε represent the difference between filaments angles to the origin of coordinate system, r is the distance between them and M is the mutual inductance between those filaments. Self-inductance is calculated by the sum of all M terms that relates all current filaments of two different turns (i and j filaments) as in Eq.(4).

$$L = \sum_{i=1}^i \sum_{j=1}^j M_{ij} \quad (4)$$

The last coils parameter to be determined is parasitic capacitance. Each turn is separated from another one by an insulating material (air or another material), then, a capacitor is formed between coils turns. The total capacitance of a wire coil is, in general, very small and different approaches are available in the literature to find its value. In this work it is used the Eq.(5), one empirical equation to approximate the coil total capacitance (Knight, 2010).

$$C = (4\varepsilon_0 / \pi) l [1 + 0.8249(D/h) + 2.329(D/h)^{(3/2)}], \quad (5)$$

where h is coil length and D is coil diameter, both values in meters. For main coils used in this work were considered constructive parameters shown in Table 2.

Table 2. Main coils constructive parameters

Parameters	Values
a	0.4059 mm (20 AWG)
r	25.40 mm
n	10
h	8.11 mm
D	50.81mm
σ	61,7 S.m/mm2

Calculated and measured values obtained are shown in Table 3. As can be observed it was found a good agreement for inductance values. As the coils parasitic capacitance it is very small, it was not possible to measure this value directly, so the measure was indirectly made by the resonance frequency and inductance measured values.

Table 3. Calculated and measured main coil parameters

Parameter	Calculated	Measured
TMC (L)	8.54 μ H	8.38 μ H
RMC (L)	8.54 μ H	8.28 μ H
TMC/RMC (C)	3.94pF	4.01pF
TMC Resonance Frequency	27.437MHz	27.429MHz
RMC Resonance Frequency	27.437MHz	27.621MHz

The values of the resonance frequency of the TMC and RMC showed on the table 3 above are too high for the purposes of the projected PEC, therefore, external capacitors were associated in parallel with both units in order to achieve the frequency range of 800 kHz to 1,6 MHz. On the next topic, the results of the transmission and PECs efficiency were measured and compared for different distances and frequencies.

5 EXPERIMENTAL RESULTS

In order to verify the WPT system functionality and efficiency it was connected to a 1 k Ω resistive load and was tested in frequency range from 0.8 MHz to 1,6 MHz. The distance between TU and RU was ranged from 2 cm to 8 cm. The efficiency values obtained are presented in Figure 4.

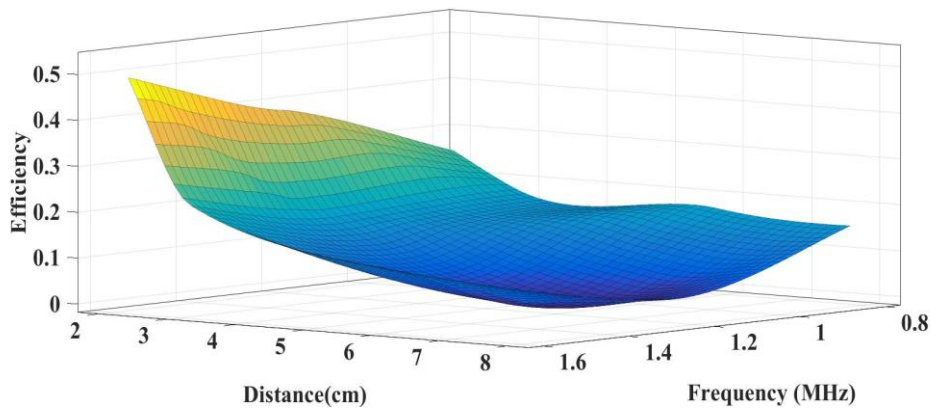

Figure 4. Wireless Transmission Efficiency

It is possible to observed that the greatest efficiency occurs with the increase of frequency with the minimum distance between the coils. It is important to inform that the efficiency was calculated using the values of voltage and current measured on the load, that is, the measured data were collected considering the losses on PEC. Therefore, the maximum point of the curve is 55% of efficiency, 2 cm of distance and the PEC operating in 1.6 MHz.

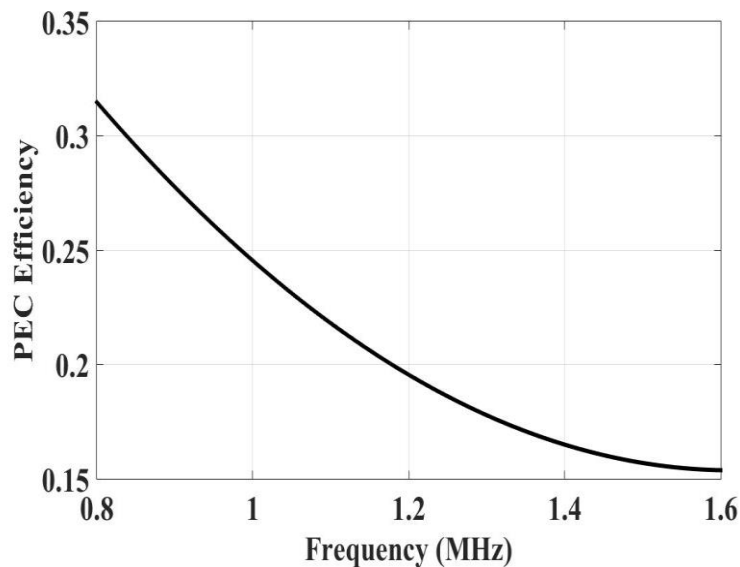

Figure 5. PEC Efficiency

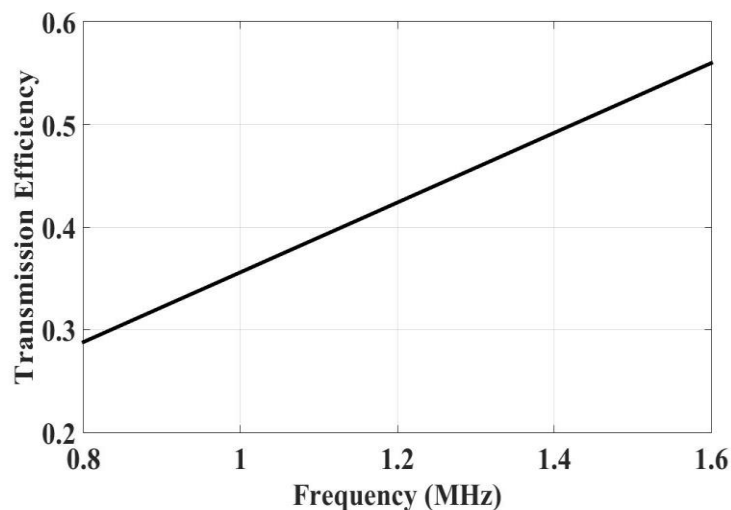

Figure 6. Transmission Efficiency

The PEC and wireles transmission efficiencies were illustrated separately in Figures 5 and 6, respectively.

The PEC efficiency decreases with the increase of the resonant frequency due to losses by joule effect on the switching devices. In order to maintain the constant efficiency, it is necessary a good cooling system on the power mosfets. The transmission efficiency, on the

range of study, increases as frequency increases. These data were collected with 2 cm of distance between the transmitter and receiver units.

6 CONCLUSIONS

In this brief paper, it was developed and evaluated a complete WPT system. Results presented in topic 5 demonstrate. Some considerations on WPT system are:

Transistors used in mounting test were not properly recommended to RF application. Therefore, it is recommended to use RF semiconductors as gallium arsenate to decrease switching losses, since, gate parasitic capacitance in these semiconductors is smaller.

Board parasitic capacitance must be taken into account if a high switching frequency is used, because it is in the same magnitude range of coil parasitic capacitance, and in some cases it has much higher values. As, in this work, board parasitic capacitance achieve 100pF. Those values were measured based on network analyzer.

The oscillation in the output of the PEC presented in this paper is only achieved if an external capacitor is connected in parallel with coil since Transmitter Unit in Fig. 1. Coil parasitic capacitance, developed in this work, is not sufficient to achieve oscillation behavior. Another important consideration about this external capacitor is its thermal behavior, this component must be cooled and its terminals must be less than possible to prevent electromagnetic interference.

The increase of resonant frequency is directly proportional to transmission efficiency but the PEC's efficiency decreases. Therefore, it is necessary find an optimum point of operation between them.

Further work will be concerned to increase WPT system efficiency by optimizing PEC with exchange of semiconductor, and then increase switching frequency. Adding to it, other coil geometries will be take into account.

ACKNOWLEDGEMENTS

This work has been supported by the Brazilian agencies FAPEMIG, CAPES, CNPq, CEFET-MG and UFMG.

REFERENCES

- Brown, W. C., 1984. The History of Power Transmission by Radio Waves. pp. 1230-1242.
- Kurs, A. et al., 2007. Wireless Power Transfer Via Strongly Coupled Magnetic Resonances. *Science*, Volume 317.
- W Wei, Y. K. N. K. T. A., 2014. Characteristic Analysis of Double Spiral Resonator for Wireless Power Transmission. January.
- Jonah, O. & Georgakopoulos, S. V., 2013. Wireless Power Transfer in Concrete Via Strongly Coupled Magnetic Resonance. 3 March.

Bonifácio, N., 2009. "Transmissão de Energia Sem Fios".

Wenzhen, F., 2008. Analysis of Transmission Mechanism and Efficiency of Resonance Coupling Wireless Energy Transfer System in Electrical Machines.. *ICEMS*.

Balanis, C. A., 2005. Antenna Theory Analysis & Design.

J. C. MAXWELL, 2002. A Treatise on Electricity and Magnetism, Oxford Classic Texts in the Physical Sciences, No 1, New York.

Queiroz, A. C. M. d., 2003. "Cálculo de Indutâncias e Indutâncias Mútuas pelo Método de Maxwell". "*Semana da Elerônica*", September.

Knight, D. W., 2010. *The Self-Resonance and Self-Capacitance of Solenoid Coils*. [Online] Available at: www.g3ynh.info/. Accessed in: March 2016.