



Smith ScholarWorks

Theses, Dissertations, and Projects

2013

Are you my motherboard? : the effects of technology on the parent-child relationship

David S. Sullivan

Follow this and additional works at: <https://scholarworks.smith.edu/theses>



Part of the [Social and Behavioral Sciences Commons](#)

Recommended Citation

Sullivan, David S., "Are you my motherboard? : the effects of technology on the parent-child relationship" (2013). Masters Thesis, Smith College, Northampton, MA.
<https://scholarworks.smith.edu/theses/931>

This Masters Thesis has been accepted for inclusion in Theses, Dissertations, and Projects by an authorized administrator of Smith ScholarWorks. For more information, please contact scholarworks@smith.edu.

David Sullivan
Are You My Motherboard?
Effects of Technology on the
Parent-Child Relationship

Abstract

New technologies have been evolving at a rapid pace over the last few decades. The convenience afforded by many technologies presents interesting questions in terms of attachment. Recent research on internet addiction disorder (IAD) has revealed that technology may be affecting people on a social, familial, and neurophysiological basis. This research explores the effects of technology on the parent-child relationship. The research interviewed six participants through telephone interviews: treatment participants (TP, n=2) in this research are both young men who meet criteria for IAD and completed treatment relative to their technology addiction; clinical participants (CP, n=4) in this research are clinicians that work in treatment centers that serve clients that meet criteria for IAD. Interviews were transcribed, coded, and analyzed. Due to the small sample size, this study's findings are not generalizable; however, there were still some interesting findings and considerations. This research identified some common behavioral patterns in people with IAD and their families. Additionally, study participants suggest that failure to recognize and treat IAD will likely result in persistence of symptoms. Findings may be of interest to clinicians in addition to future research.

Are You My Motherboard?

Effects of Technology on the Parent-Child Relationship

A project based upon independent investigation,
submitted in partial fulfillment of the requirements
for the degree of Master of Social Work

David Sullivan

Smith College: School of Social Work
Northampton, MA 01060

2013

ACKNOWLEDGEMENTS

Like any large project, many people were involved in the creation of this thesis. I'm forever grateful of those that reached out to me to help in whatever ways that they knew how. There are several people that I would like to thank in particular, without these people, this thesis would still be a stack of blank pages.

First and foremost, my parents, who have supported me in so many ways throughout the years. I have found my education at Smith to be nothing short of superb, and I couldn't have made it through without their help. My dad, went above and beyond by proof-reading my work and returning it with comments in less than three days. You guys are awesome, thank you both.

My research advisor, Colette Duciaume-Wright, for helping me through what turned out to be an incredible process. There were several points in creating this thesis where her support helped me through what could have been some potentially nerve-racking experiences. Thank you for sharing your exceptional wisdom, guidance, and support.

Hilarie Cash, for her extensive professional network and knowledge pertinent to technology addictions. This project was born out of a conversation that I had with Hilarie in September. I can honestly say that I've enjoyed writing this thesis, and I don't know that I would have arrived at such an interesting topic without her intriguing perspective; and there surely wouldn't have been any reSTART participants to interview if it weren't for the wonderful program that she and Cosette Rae run. Thank you for helping me discover so many crucial resources and for being so accessible throughout my work.

And last, but certainly not least, my fiancé Danni. For letting me turn various parts of our house into my "personal office" at any given moment, for taking care of our pets despite their spastic incompatibility, for researching and planning our wedding while I return to finish school, and especially for fielding my unpredictable mood swings that came out of the whole graduate school process. I could not have done this without her unconditional support. I love you. Thank you.

TABLE OF CONTENTS

ACKNOWLEDGEMENTS	i
TABLE OF CONTENTS.....	ii
LIST OF FIGURES	iii
CHAPTER	
I INTRODUCTION	1
II LITERATURE REVIEW	6
III METHODOLOGY	62
IV FINDINGS.....	72
V DISCUSSION.....	80
REFERENCES	98
APPENDICES	
Appendix A: HSR Approval Form	112
Appendix B: Approval from reSTART for Recruitment.....	113
Appendix C: Approval from Insight Intensive for Recruitment.....	114
Appendix D: Online Gamers Anonymous Email Approval to Recruit	115
Appendix E: List Serve Email Approval to Recruit	116
Appendix F: HSR Approval for Expansion of Recruitment.....	117
Appendix G: Sample Recruitment Letter	118
Appendix H: Sample Consent Form - Treatment Participants	119
Appendix I: Sample Consent Form - Clinical Participants.....	122
Appendix J: Interview Guide	125
Appendix K: Sample Data Collection Form - Treatment Participants	126
Appendix L: Sample Data Collection Form - Clinical Participants	128
Appendix L: Referrals for Research Participants	129

LIST OF FIGURES

Figure	Page
1. The two-dimensional model of individual differences in adult attachment	26
2. The two regions of the prefrontal cortex (dorsolateral and orbitomedial) and the anterior cingulate cortex	44
3. Noted areas of the limbic system: the ventral tegmental area, amygdala, nucleus accumbens, caudate nucleus, and the hippocampus	46
4. Medium spiny neuron firing relative to damage inflicted to the hippocampus	48

CHAPTER I

Introduction

Communities in America are facing a new crisis. Mental health of American youth is deteriorating at an alarming rate as we witness high and rising rates across multiple mental health diagnoses; researchers attribute this phenomenon to a new lack of inner-connectedness (Blankenhorn, 2008). While many may argue that we feel more connected than ever due to modern technology, there is research that would suggest otherwise (Lapidot-Lefler & Barak, 2012; Siomos et al., 2012). Attachment theory posits that most individuals pass through four crucial attachment phases by four years of age (Marvin & Britner, 2008). With the advent of modern technology occupying more time in the lives of children (Common Sense Media, 2011), in lieu of parent-child interactions, what consequences can we come to expect? There is a burgeoning need to explore the effects of technology on the parent-child relationship.

In their study of nearly 1,400 parents, Common Sense Media (2011) found that two year-olds are spending twice as much time watching television as they are reading books and children under eight years old are becoming increasingly tech-savvy. Why is this relevant to technology use? In his latest work, *The Science of the Art of Psychotherapy*, Allan Schore (2012) asserts:

In 1996, I proposed, "the self-organization of the developing brain occurs in the context of a relationship with another self, another brain." This book, like its three predecessors, presents the reader with a continually expanding body of

recent interdisciplinary data that indicates that these principles are now accepted in both the life sciences and the mental health field. (p.18)

Fonagy and Target (2005) continue:

If the attachment relationship is indeed a major organizer of brain development, as many have accepted and suggested (e.g. Schore, 1997, 2003), then the determinants of attachment relationships are important far beyond the provision of a fundamental sense of safety or security (Bowlby, 1988). (p. 334)

If human brains organize other human brains as these authors suggest (Fonagy & Target, 2005; Schore, 2012), and others corroborate (Lewis, Amini, & Lannon, 2000), what happens to children when computers are inserted in place of care-givers? In some extreme cases, children as young as four years of age are being treated for their addiction to the family iPad (Ward, 2013).

Cash and McDaniel (2008) reflect:

All children need to feel securely nestled in their families. When this security is absent, a child feels a desperate longing for the attachments that are missing. For a person feeling a lack of emotional security, safety, and love, screen time provides a distraction and a substitute. *Online communities substitute for real-life communities.* (p. 67)

In his book, *Hooked on Games*, Dr. Andrew Doan (2012a) recalls his own experiences battling video-game addiction in addition to his own research suggesting that IAD can fill numerous purposes in the life of an addict including: escaping from reality, providing a sense of purpose, satisfying one's needs for challenge, gratify one's desire to be a leader, fulfilling sexual fantasies, and most importantly, meeting the need for love and acceptance. Addiction to a device is a bizarre concept to consider, but when considering research on the brain's response to video game

stimuli (Han et al., 2011; Han, Kim, Lee, & Renshaw, 2012; Ko et al., 2009; Zhou et al., 2011), or the brain's reward pathways in those affected by internet addiction disorder (IAD; Dong, Huang & Du, 2011; Han, Lyoo, & Renshaw, 2012; Hou et al., 2012; Kim et al., 2011), then one would notice similar brain regions involved in cases regarding other addictions (Green & Ostrander, 2009). This confluence of research suggests technology may have a heavier impact on people than traditionally considered; further anecdotal evidence adds to this possibility.

In her examination of data usage on the internet, Krystal Temple (2012) made a staggering realization:

Today, the number of networked devices equals the world's population. By 2015, the number of networked devices is expected to be double the world's population.

And by the time we reach 2015, it would take five years to view all the video content crossing IP networks each second. (paragraph 4)

Considering that not everyone on Earth has a device that connects to the internet, those that do must have multiple devices; the amount of time people are using these devices surely adds up.

Teachers in the United States who were interviewed regarding technology's modern influence reported a switch in student learning styles. They felt it was affecting students' ability to learn and think critically (Richtel, 2012). Some teachers reported what they referred to as the "Wikipedia problem" (Richtel, 2012, paragraph 18), suggesting that students are less able to tolerate searching for an answer to a problem and quit after less time trying. Carr (2011) explains that several famous newspaper publications have adapted their content to shorten the length of their articles to adapt to what one editor referred to as "an internet age, a headline age" (as cited by Ramey, 2007, p.123).

In other parts of the world, China's government has recently taken steps to reduce internet addiction amongst its population by developing methods for effectively diagnosing and treating IAD (Yin & Wangshu, 2013). In South Korea, the estimated 30 million people playing video games (or "gaming") has become so problematic that the government has begun intervening with litigation that includes a curfew for gamers under 18 between the hours of midnight and eight a.m. (Cain, 2010). This litigation coming as South Korea has been gaining notoriety as a digitally-wired society, so much so that tragic events related to technology have been occurring there for years, including a three-month-old baby starving to death while her parents nourished a digital baby online (Cain, 2010). Events such as these aren't relegated solely to South Korea, as several technology-linked incidents have recently taken place in the United States as well (Connor, 2013; Hunt, 2010; McCabe, 2013; McCarthy, 2009; Quigley & Farberov, 2013), including the tragedy at Sandy Hook Elementary in Newtown, Connecticut (Altimari, Mahony, & Lender, 2013). In addition to mental health stipulations, a mounting body of research suggests that this increased exposure to technology may also have significant effects on humans physically.

In her exploration of teenage technology use, Victoria L. Dunckley (2013), presents some concerning research that suggests screen time (using screen-related technologies) may cause: "stress, inflammation, and changes in blood sugar regulation, all of which may contribute to risk for metabolic syndrome" (paragraph 2). Metabolic syndrome's symptoms include an increased waist size (37" for men, 32" for women); raised blood pressure, triglycerides, and blood pressure sugar; and low "good" cholesterol (Dunckley, 2013). These all sound like symptoms one might expect to see in the second half an individual's life, rather than the first quarter. Rosen (2012) presents other physical maladies being reported in congruence with technology overuse.

By reviewing the literature surrounding these alarming trends, and then interviewing both treatment participants and clinical treatment providers of technology abuse, this study attempts to shed some light on what appears to be an emerging societal quandary by exploring: "What are the effects of technology on the parent-child relationship?"

CHAPTER II

Literature Review

In order to consider a topic such as the effects of technology on the parent child-relationship, one must first understand several concepts central to the topic. Various facets of attachment are especially important in this epistemological conquest. However, regardless of how well one masters the primary attachment stages, there is still much to be learned about the subsequent evolution of attachment (Marvin & Britner, 2008) and its relationship to one's neurophysiology. This discussion gets even more complicated when we consider the sophistication of many modern-day technologies. In many cases technology serves to make our lives easier. Whereas thousands of years ago one's primary concern would be survival or the survival of one's offspring, in present day it is also common to worry about something more trivial, such as which restaurant to eat at. The difference between the dining experiences over the past 1000 years has obviously evolved dramatically. Journey back 1000 years when hunting for live prey was the preferred method of eating meat; now, one can merely pull out their smartphone and make reservations at a restaurant before they even leave the office. You may be asking: "What does this all this talk about food have to do with computers or televisions?" The answer is convenience.

Our body's attachment system functions as a means of survival. As the definition of survival becomes more complex with the integration of technology (i.e. from physical to social, emotional), so too does the definition of stress; the attachment system readily redefines stress to

adapt to this new definition including technology (Marvin & Britner, 2008). Technology and invention aren't only representative of humankind's innovation, but also our quest for convenience. A good example of this is personal travel, where civilization developed from horseback, to train, to automobile, and finally to airplane. This evolution has come with the expectation that we can now do more in less time. Unfortunately for our brain, we are still utilizing the same attachment networks in the present day as we were 1000 years ago.

In order to better understand this evolution, I will present five key topics: (a) I will present the evolution of many of the modern technologies that we appreciate in the present, with particular attention to the last 50 years. (b) I will discuss the importance of attachment literature to the subject at hand. (c) I will examine relevant neurobiology research. (d) I will explore current literature on addictions. (e) And finally, I will illustrate how all of this ties into what is being called Internet Addiction Disorder (IAD).

A Brief History of Technology

When speaking about technology, I'm referring to three areas of "gadgetry": screen technology (computers, televisions, as well as smart phones), music technology (radios, cassette players, CD players, and mp3 players), and social technology (telephones, cell phones, and social networking websites). Over the last several decades, these technologies have seen an incredible evolution. Telephones entered the technological spectrum when Alexander Bell had this invention patented in 1876 (much to the chagrin of Elisha Gray, another inventor that created a similar device; "Technology timeline," n.d.). Nearly fifty years later, radio station KDKA made the first commercial broadcast, followed by televisions making their debut in the 1927 ("Technology timeline," n.d.). But it wasn't until after the second World War that these gadgets began to see a significant boom.

The Sixties and Earlier: Beginnings. In 1954, the portable transistor radio ("Technology timeline," n.d.) was developed. Here we see a departure from the typical psychological tether that previous technologies had. People could now travel with their music or information. By 1960, 85% of American households had television sets ("Historical periods in television," n.d.). In other screen technology, computers (invented in 1939; "Technology timeline, n.d.") were getting more user-friendly with the advent of the first consumer operating system: IBM's *OS/360* ("Technology timeline," n.d.). This allowed computers to run a more robust array of software programs. In addition, the music industry was getting a new look at delivering music through the cassette tape released by Phillips in 1965 (Strauss, 2007). 1967 brought an upgrade in television as television was mostly in color by this point ("Historical periods in television," n.d.). While consumers of this age became accustomed to their plethora of new tools, companies were already looking ahead to the next developments.

The Seventies: Technology's Bronze Age. Ray Tomlinson probably had no idea the impact his electronic message would have when he sent the first email in 1971 ("Timeline of computer history," 2006; Curtis, 2013). While email was still decades away from becoming part of household lexicon, television was becoming increasingly popular as half of American households had a color television by 1972 ("Historical periods in television," n.d.). In 1979 music enthusiasts were rewarded with Sony's *Walkman* (Strauss, 2007) which allowed music enthusiasts to now listen to their music while they walked. Doing one thing at a time is becoming a thing of the past for tech-savvy consumers. 1976 brought Milton Bradley's *Simon* and Mattel's line of handheld games (Kent, 2001); roughly the size of a calculator, these games added to the array of handheld portable electronics. Handhelds occupied a unique niche in the

technology market; however, it would pale in comparison to the burgeoning video game industry.

In 1972, the company Atari made and released *Pong*, a game that would forever canonize itself amongst video game enthusiasts (Kent, 2001). Intended to resemble a ping-pong game, two players controlled inch-long white paddles and took turns reflecting a tiny white square that represented a ball. The ball caromed off the walls of the game, the objective being to get the ball past your opponent's paddle. While there were other video games before it (Steve Russel's *Space War* and Sega's *Periscope*; Kent, 2001), this game arguably would galvanize the American video game industry. Atari recognized the proverbial golden goose they were sitting on and they continued to manufacture new titles. Within 10 years, Atari became a two billion dollar a year multimedia juggernaut, making it the fastest growing company in American history at the time (Kent, 2001).

The Eighties: The Golden Age. The eighties brought several advances in technology, maybe most importantly being the rise of in-home computing. Computer technology makes its way into film with Disney's 1982 release of *Tron* ("Timeline of computing," 2006). Commodore, IBM, and Apple fuel competition as they begin offering more user-friendly home-computer systems ("Timeline of computing," 2006) known as personal computers (PCs). This development was so significant that, in lieu of a person, Time magazine declared computers the "Machine of the Year" for 1982 ("Technology timeline," n.d.). Three additional advances in the world of computers come to consumers when Epson releases the first laptop in 1983, followed by Apple's release of the Macintosh in 1984, and subsequently by the release of Microsoft Windows in 1985 ("Timeline of computing," 2006). CompuServe and Prodigy began providing

online services in 1984. By the end of the year they would have over one million users (Curtis, 2013). While computers were gaining momentum, video games continued to burgeon.

In 1981, Americans spent over 75,000 hours playing arcade games, sky-rocketing revenue above 5 billion dollars (Kent, 2001). The industry was booming and a spectrum of game use was beginning to develop. From the arcade neophyte who would play a couple dollars worth of games while hanging out with a group of friends, to 15 year-old Steve Juraszek who set a world record (15,963,100 points) during a 16-hour long session of the game *Defender* (Kent, 2001). Juraszek's feat would get him on the cover of Time magazine, but also galvanized communities of who began lobbying for legislation for arcade curfews (Kent, 2001); in the Philippines, Ferdinand Marcos had already taken similar actions (United Press International, 1981); Although this did little to slow the industry that would continue to produce new games.

Games that make for nostalgia amongst most people in their 30s emerged in this decade. *Pac-Man*, *Defender*, *Donkey Kong*, *Pitfall*, *Ms. Pac-Man*, *Dragon's Lair*, and *Tetris* would all be released before Nintendo of America made its big entrance into the American Market (Kent, 2001). Two years after its release in Japan, Nintendo of America announced the release of its *Nintendo Entertainment System* (NES) to the United States in 1986 (Kent, 2001). Nintendo went on to sell 1.8 million NES consoles in their first fiscal year release, 5.4 million in the next year, and 9.3 million in the subsequent year. As Nintendo became a household name, other technologies were emerging as popular items amongst the American public.

By 1980, much of the American public was becoming dependant on their television as their source for the news, so much that CNN was launched by Ted Turner. This 24-hour news network marked a significant point in the country's history in that people no longer needed to wait until the next day to see news from around the world. In 1983, 125 million viewers tuned in

for the season finale of *M*A*S*H*, still hailed as the most watched finale in the history of television (Littler, 2011). In addition, tapes were beginning to see competition from compact discs (CDs) released in 1984, followed by Sony's release of the *Discman* in 1985. Music technology gains a few seconds of convenience as users no longer need to fast-forward or rewind between tracks. By 1998, 98% of American households had at least one television set ("Broadcasting timeline," 2007). Americans were becoming increasingly attached to their technology, especially their screens, and by 1989 they would be getting used to a new concept entirely as scientists were working on what would be known as the "world wide web" (Curtis, 2013).

The Nineties: Getting Connected: The radio continued to be a reliable source of information for Americans in the 90s, as 99% of American households have at least one radio, with the average being five. But that would begin to shift with the advent of the world wide web; sources for news and information were beginning to shift. PCs increasingly became multimedia machines ("Timeline of computing," 2006), a critical transition for the PC industry. Whereas initially they were being used primarily for word processing and data management, it became commonplace for PCs to come loaded with multimedia technology such as sound, picture, television, and video programming. While there were several companies producing games for PCs in the eighties, the games produced in the nineties began to demonstrate the PC as a potential competitor for home console systems and arcade games.

In 1993, the Pentium processor was released ("Timeline of computing," 2006) with increased capabilities that allowed PCs to run more dynamic games such as the controversial title: *Doom*. *Doom* was the successor to a game called *Wolfenstein 3D*. Both games were considered "first-person shooters", where the player runs through maze-like levels shooting

enemies. What set these games apart from the other shooters was the open display of gore. Where enemies in other games merely disappeared or fell to the ground, the dead in these games fell to the ground bleeding profusely (Kent, 2001). Both games were distributed and promoted using a marketing method referred to as "shareware". Developers created a certain segment of the game (such as the first level, or 10 minutes of game-play) that is available to players for free. Once they've played the game, players can decide whether or not to purchase a complete version (Kent, 2001). This style of marketing allowed small market companies like *id* (the aptly named developer of *Wolfenstein 3D* and *Doom*). Kent (2001) explains what set *Doom* apart:

When the project was complete, everyone in the company knew they had a sure-fire hit. Not only did *Doom* have more gore than *Wolfenstein 3D*, it was decorated with Satanic symbols and populated with demons, images that thrilled gamers but infuriated critics of the gaming industry. Since it was originally released as shareware, however, the critics did not notice it until a few months after its release. In the meantime, *Doom* created a phenomenon unlike any PC game before it. (p.459)

Given the circumstances, it's obvious that such a game drew such harsh criticism from video game critics. It was surprising when *Doom* did not come up often at the senate committee hearings on video game violence in 1993.

Several games would be catalysts for what many critics felt was a long overdue conversation about videogame violence on a national stage. Senator Joseph Lieberman (Democrat, Connecticut) began arranging for hearings on video game violence after hearing about the violence depicted in certain games. His concerns reportedly grew after he conferred with his constituents only to discover a common parental lack-of-awareness on the subject (Kent,

2001). Concerned with the idea that violent games were being peddled to young children, Lieberman and Senator Herbert Kohl (Democrat, Wisconsin) presided over the hearings that began in late 1993. Despite its obvious gore, games like *Doom* were largely ignored during the hearings based on their cartoonish appearance, whereas all three of the games which the hearing was primarily focused on used digitized human-beings (Kent, 2001; Kohler, 2009). The result of the hearings was the Video Game Rating Act of 1994, whose purpose is: "...to provide parents with information about the nature of video games which are used in homes or public areas, including arcades or family entertainment centers" (S. 1823, 1994). In addition, all the major players from the video game industry created the Entertainment Software Ratings Board (ESRB) after much deliberation (Kent, 2001). The ESRB was responsible for implementing a game-rating system. Similar to movie ratings, the system acted as a quick reference for parents to understand audiences appropriate for the game being rated. There were two parties in particular that drew attention from Senator Lieberman during the hearings. Howard Lincoln (representing Nintendo), and Bill White (representing Sega) were using the hearings as an opportunity to sully each other's brand so much that Lieberman (as cited by Kent, 2001) reported:

I was surprised when Howard Lincoln and Bill White went after each other like that. I thought it looked awful. And I was surprised by the intensity of it. I guess it gave me this message that this was obviously big business. (p.477)

And he was right; the two console giants had been locked in industry battle that began at the beginning of the decade.

Over the five years prior to the senate hearings, Sega and Nintendo had found themselves at odds as the two major home console industry competitors. Sega released its *Genesis* the same year Nintendo released its *Gameboy*. *Gameboy*, a handheld mobile gaming device offered

variations on popular Nintendo titles in black and white. The *Genesis* was a step up (a 16-bit system) from the eight-bit NES, and a legitimate industry threat. With a slogan like "Sega does what Nintendont", Sega was out to contest the gaming goliath that Nintendo had become. In 1990, Nintendo would release its 16-bit system the *Super Nintendo Entertainment System* (SNES), but the damage was done; with *Sonic the Hedgehog* Sega had successfully created a mascot to compete with Nintendo's *Mario Brothers*. Sega skillfully maneuvered itself through the gaming market and ended up improving sales from \$100 million in 1990, to \$1billion in 1993 (Kent, 2001). While the SNES would eventually overcome the Genesis as the more popular gaming system, the two consoles captured the zeitgeist of gaming enthusiasts young and old for the greater part of the decade. Nintendo would go on to release the Nintendo 64 in 1996, further driving a nail into the rest of the gaming industry's coffin. And while Sony had released its *Playstation* (Kent, 2001) one year prior, Nintendo seemed to be cemented in place as the supreme console company. Of course, the nineties also brought other technological gadgets and programs.

In 1993, several companies released business management devices that are small enough to carry in one's pocket, dubbed the *Personal Digital Assistant*, or "PDA" for short ("Timeline of computing," 2006). PDAs entered the consumer market at an opportune time, as that very same year, scientists at the European Organization for Nuclear Research donated the world-wide-web to the world following the release of the Mosaic web browser (Curtis, 2013). Computers were starting to move from being a device for the technically-inclined, to an everyday tool for the layman.

In 1995, Microsoft released *Windows 95*. The first *Windows* edition in which the "Start" button is introduced, it sold a record-setting seven million copies in its first five weeks ("A

history of Windows," n.d.). Bill Gates recognized the importance of the internet decriing it as: "the most important development since the advent of the PC" ("A history of Windows," n.d., paragraph 28). Microsoft would release *Internet Explorer* in response to the rapidly developing internet ("A history of Windows," n.d.). At the time of the *Windows 95* release, 80% of PCs were running a previous version of *Windows* or *MS-DOS* (a text-based operating system), *Windows 95* was the upgrade for the DOS operating systems ("A history of Windows," n.d.). With so many people getting software that made the internet readily available, social media began to flourish.

February 26th, 1995; Clifford Stoll published an article in Newsweek titled "The Internet? Bah!" in which Stoll contests predicted trends such as the internet replacing newspapers, computers becoming a common part of classrooms, and the emergence of e-business. Stoll would uncannily identify several important emerging trends, but couldn't be more far-off in predicting that none of them would be commonplace within households. Several internet trends would emerge in the coming years including instant-messaging, social networking, and blogging. These social technologies represented a shift in thinking, as both open displays of personal information and instantaneous information acquisition are becoming more common. Additionally, television programming in the nineties also began to transform.

1990 brought two popular American television shows: *Seinfeld* and *The Simpsons*. While both regularly expressed controversial topical humor, the *Simpsons* represented an altered attitude in the American people. President and First Lady, George and Barbra Bush, made comments deriding the emerging cartoon show (Paakinen, 1999). Another example of the shift in attitude came in 1991; Fox became the first network to allow for condom advertisement

(Curtis, 2013). The shift in what was appearing on television eventually caught the attention of President Clinton.

The Telecommunications Act of 1996 was intended to foster competition between television station owners and diversity amongst perspective ("Television in the United States," 2013); however, others argued that the act merely created an opportunity for corporate profits (Common Cause, 2005). Common Cause (2005) postulates: "...the public got more media concentration, less diversity, and higher prices" (p.3). The re-regulation that occurred following the act created two primary changes: stations were now required to air at least three hours of children's programming each day, and the parental guidance rating system went into effect ("Television in the United States," 2013). The new focus on family-values resulted in a rating system that consisted of six different ratings ranging from children's content to programming for adults age 17 and older ("Television in the United States," 2013). Critics of the rating system would deride it for its subjectivity and focus on sexual and violent content, some even referred to it as censorship ("Television in the United States," 2013); but over the following years, violence defined several national tragedies.

October 1st, 1997; a 16 year-old white male of Pearl, Mississippi, violently murdered his mother then proceeded to kill three students and wound several others before being subdued at gunpoint by a school official (Kent, 2001). December 1st, 1997; a 14 year-old white male of Paducah, Kentucky, shot and wounded 8 students who had gathered for prayer. He was wrestled down when he paused to reload his gun (Kent, 2001). March 24th, 1998; two young white males pull their school fire alarm only to open fire on the unsuspecting school body from afar (Kent, 2001). May 20th, 1998; a recently expelled 15 year-old white male shot and killed his parents, then set up booby traps around their bodies. The next day, the teenager returned to his school

with a .22 caliber rifle. The shooter is eventually wrestled to the ground by several students (after shooting 24 and killing 2) as he screamed "Shoot me!" (Kent, 2001; Mortenson, 2008). And finally, probably the most notorious event in Littleton, Colorado: on April 20th, 1999; two teenage white males (17 and 18 years old), carried out one of the bloodiest assaults on a school body. The two young men killed 13 (12 students, 1 teacher), leaving 23 injured, before taking their own lives. After the tragedy, investigators uncovered footage recorded by the killers. While reclining in a La-Z-boy chair, a bottle of whiskey in one hand, a sawed-off shotgun in the other, one of the young men avers: "I hope we kill 250 of you" (Gibbs & Roche, 1999, paragraph 5). His associate follows: "It's going to be like f***ing Doom, tick, tick, tick, tick... Haa! That f***ing shotgun is straight out of Doom!" (Gibbs & Roche, 1999, paragraph 6). With *Doom* explicitly noted in the video, a national conversation was in order; however, the corresponding hearings arranged by Senator Sam Brownback (Republican, Arkansas) didn't make a big impact, as even senator Brownback (as cited by Kent, 2001) conceded: "Not much came out of the hearings. It was a nice discussion, but I haven't seen much follow-up" (p.555).

Several other technological innovations squeaked out prior to the turn of the millennium that would carry into the coming years. In 1997, wireless technology gets perhaps its greatest contribution with the advent of "Bluetooth" technology ("Timeline of computing," 2006), which quickly became a business standard. Then in 1998, Andy Bechtolsheim (co-founder of Sun Microsystems) would write a \$100,000 check to a company that didn't even exist yet, by the name of "Google Inc." ("Our history," n.d.). Within 8 years, "google" would enter *Merriam-Webster* as a verb, based on its popularity as a search engine (Anderson, 2006). And finally, in 1999 a student at Northeastern University would release a file sharing program that targeted mp3

files on user's computers. Shawn Fanning's *Napster* (aptly named after his childhood nickname) would catch the world's attention, as well as most of the music industry...

2000 and Beyond: Plugged In. *Napster* changed the music industry forever. As a free program that allowed for limitless exchange of mp3 files, *Napster* also divided the music industry: bands were either for it, or against it; just a little more than a year after its release, the band *Metallica* sued *Napster* (and 3 universities as well) for copyright infringement (Uhelszki, 2000). This would mark the beginning of the end for *Napster* as many fondly remember, but the damage was already done. The pressure on *Napster* to cease operations and submit to a pay-for-service structure didn't prevent copycat programs from springing up. In her exploration of *Napster's* effect on the music industry, Mary Madden (2009) posits:

...while *Napster* morphed from its lawless larval stage to a dues-paying music service, consumers in search of free content have had their pick of surviving peer-to-peer applications and torrent sites that more than make up for the loss of the original rogue site. (p.3)

The mp3 revolution had begun, and Apple had just the device to run the software.

While other companies released mp3 players several years before, none of them would compare with the revolutionary, user-friendly design of Apple's "iPod" released in 2001 (Strauss, 2007). The iPod was accompanied by specific software for loading music onto the device: "iTunes." The iTunes software caught on to the emerging mp3 market, offering its users many of its mp3s for a mere 99 cents. When Apple announced it was releasing a mobile phone, consumers listened.

Apple released the "iPhone" in 2007 ("iPod + iTunes timeline," n.d.). Like other Apple products, the iPhone came with user friendly design and interface including touch-screen

technology, but it also came with novel software that Apple called "apps", short for applications. "There's an app for that" became a common phrase as Apple's apps fulfilled a variety of functions that simultaneously glamorized the iPhone's advanced technological capabilities. The same multimedia versatility that PCs displayed before the turn of the century was now available in one's pocket.

Apple's products took the consumer market by storm, and by 2010, 275 million iPods had been sold, the iTunes store had sold 10 billion songs and 5 million apps ("iPod + iTunes timeline," n.d.). That same year, Apple released the iPad, a touch-screen portable computer that combined various features of the iPhone and Apple's desktop computer. Over the first 10 years of the new millennium, the internet went from a punch line in a joke about geeks, to an essential technology.

The internet evolved at an astonishing pace. In his book *Drive*, Daniel Pink (2009) describes the unpredictable phenomenon in a clever allegory. Pink asks readers to imagine that the year is 1995 and they are asking an accomplished economist to predict a more successful encyclopedia brand. Pink describes the options objectively before revealing that the first option describes the business model of Microsoft's *Encarta*; the second model describes *Wikipedia*, the entirely user-driven internet sensation that would effectively end *Encarta*. People were taking to the internet and, in addition to *Wikipedia*, social-networking was born.

Several social-networking sites would emerge in the new millennium, but over the course of several years, Facebook would establish itself as the colossus of social networking, amassing 750 million users ("Top 15," 2013). Facebook would capitalize on emerging trends including allowing users to post videos from the new site *YouTube* in 2005, and then allowing users to install apps in 2007 (Curtis, 2013). *YouTube* would eventually be bought out by Google in 2006

for \$1.65 billion (Murchinson, 2006). Another site, *Twitter*, came into social networking in 2006 (Curits, 2013) as a condensed version of its predecessors, allowing users to "tweet" a short thought, no longer than 140 characters. While it was originally used for personal expression, *Twitter* brought eye-witness-news to a whole new level.

In 2009, Jim Hanrahan broke a story on *Twitter* of a plane crash in the Hudson River 15 minutes before the mainstream media broke the story. (Beaumont, 2009; Curtis, 2013). At this point in the internet's history, we are starting to see just how quickly information is circulating. It is estimated that in 2009, roughly one quarter of the world's population is using the internet, and by 2010, that number would increase to an estimated 30% of the world (Curtis, 2013). That same year it would surpass newspapers as a primary reading source for news amongst the public (Curtis, 2013). The internet was beginning to integrate into multiple aspects of human life.

Recognizing this emerging trend, video game system developers began working on upgrades to their systems. In the new millennium, Nintendo had major competition and had lost its throne as the elite. Sony's *Playstation* (released in America in 1995) and Microsoft's *Xbox* (released in 2001) were working on upgrades just as quickly as their base models were released (Kent, 2001). Sony would release the *Playstation 2* (PS2) in 2000, followed by Microsoft's *XBOX 360* in 2005 (Skipworth, 2011). *Xbox* consoles were unique in that they had an ethernet port which eventually became part of a much bigger service: *Xbox Live*. Xbox launched this online service in 2002 (Skipworth, 2011), allowing players to access games online, never having to play alone again.

Meanwhile, having lost its supremacy, Nintendo ventured into a new technology. Following its *GameCube* in 2001, Nintendo launched the *Wii* in 2006 ("Company history," n.d.), introducing motion-sensitive controllers as well as being able to wirelessly connect to the

internet for free. Players holding the controllers would have their real life movements mimicked in-game. Thus Nintendo began the bridge from reality to virtual. The *Wii* became the best-selling late-generation console ("Company history," n.d.), although to this day Nintendo still competes with Sony and Microsoft. Outside of console games, PC games had capitalized on the surge of internet users as well.

In 2002, the game *Second Life* was released, a game which is literally a second virtual life for its users. *Second Life* isn't even so much as a game, but rather a virtual social network, where each person is represented by an "avatar" that they create. Avatars can dance, hug, fly, have sex, whatever the user would like it to do. *Second Life* is constantly changing and is arguably the most obvious representation of becoming another person in another world but this slowly became the norm for games of the 21st century.

World of Warcraft (WoW) is what's known as a massively multiplayer online role playing game or "MMORPG." WoW is a fantasy game where players create avatars that battle each other or computer generated monsters. The purpose of the game is to complete various quests throughout the game to advance the storyline. Although, the virtual-world in the game is so large, developers have created so many optional tasks for players that the game is relatively impossible to ever actually complete. In addition, players can alter their avatars to fulfill other jobs and basically start the game over. An important concept of the game is "leveling up" by fighting multiple battles. By leveling up, their players get stronger and learn new abilities. WoW's legacy began in 2005 with a following of 1.5 million players, peaking in 2010 at 12 million players, and now sitting at just over eight million (Lee, 2013; "Number of World of Warcraft," 2013). And while WoW was able to celebrate its success, it laid the groundwork for an even bigger game.

While similar in style, *League of Legends* (LoL) is considered a multiplayer online battle arena game, or "MOBA." Much like WoW, LoL has characters using avatars which they level up in a virtual fantasy world, only in LoL's case, players engage in battle often. Each time, playing in teams of five versus another team of five, the game is much like a chess match. Again, the game has a large number of different avatars that can fill a variety of different roles, learn a plethora of skills, and collect a multitude of abilities; this game is also basically impossible to finish. On top of its alluring qualities, the game is also free to play (but it does have some optional cash upgrades). Since LoL's launch in 2008 (the game was released to players for beta testing prior to its official release in 2009; Riot Games, 2008) the game has amassed 32 million players, averaging 12 million players daily, and 1 billion hours of play time monthly ("The major league," n.d.). According to Riot, LoL is the most played video game in the world. What's so important about these new games is not just the communities that they create, but that they don't end. Game designers are constantly adding new facets to assuage veteran players while entertaining the neophytes as well.

As technologies increase their influence, old ways of connecting interpersonally are disappearing. In her book *Alone Together*, author Sherry Turkle (2011) examines the disconnecting nature of the internet and technology. As video games and technology have evolved, it has moved from a viewing experience to a completely interactive multi-media experience. In explaining the purpose of her book, Turkle (2011) asserts: "...it is about how we are changed as technology offers us substitutes for connecting with each other face-to-face...As we instant-message, email, text, and Twitter, technology redraws the boundaries between intimacy and solitude" (p.11). She presents other technological introjections such as parents who prefer communicating with their family through technology as "real-time" isn't fast enough and

the curious paradox of having a following of social media friends, yet still feeling isolated.

Turkle (2011) concludes by asking: "Does virtual intimacy degrade our experience of the other kind and, indeed of all encounters, of any kind?" (p.12). Her question engenders another interesting question: in our quest for convenience, have we lost our authentic forms of expressing ourselves and connecting with others? Examining various tenets of attachment theory provides some basis for exploring whether our devices have become attachment assistants or interlopers.

Attachment

Basic Theory. John Bowlby and Mary Ainsworth are considered to be the respective father and mother of attachment theory. They are discussed by Shilkret and Shilkret (2008).

Bowlby and Ainsworth: Supervised by Melanie Klein, Bowlby was the first to bring forward the importance of the child's internal world in the 1940s. Drawing on evolutionary theory and work with animals, Bowlby proposed that all organisms have what he referred to as an "attachment system": an innate capacity of young animals to stay close to their caregivers until they have acquired sufficient skills to live in the wild, and more importantly, the ability to protect themselves from danger or death. In a serendipitous turn of events, Ainsworth replied to an ad placed by Bowlby looking for a research assistant in 1950. Ainsworth's life circumstance brought her to Uganda where she would complete what is considered to be the first study on attachment, examining the development of infant attachment to caregivers. She found infant attachment to be positively correlated with maternal sensitivity. Her findings purported the importance in quality (versus strength) of attachments; a measure still used to this day (Shilkret and Shilkret, 2008).

Ainsworth moved to Baltimore in 1955 where she embarked on another research project which would prove to be crucial to attachment literature. The study's intensive methodology

involved researchers spending 18 four-hour sessions with mother-infant dyads. By their first birthday, it was evident infants were demonstrating attachment styles. In an attempt to confirm the quality of attachment, Ainsworth and her colleagues created what would be called the "strange situation". In this experiment, the mother and infant would be joined by a friendly female (but a stranger nonetheless), in a room filled with toys. Soon afterward, the mother would leave the room for a few minutes, leaving the infant in the care of the friendly female. When she returned, quality of attachment could be measured by the infant's response to reuniting with the mother. The researchers chose three descriptors to categorize the various attachment styles, "secure," "avoidant," and "ambivalent" (Shilkret and Shilkret, 2008).

Considered the healthiest of attachment styles, secure infants were marked by distress during the absence of the mother, and welcoming of the mother's return. Secure infants utilize their mothers as a "secure base" for exploring the unfamiliar environment, as well emotional regulation. Children, who didn't display the behavior for secure attachment, fell into the insecure style, which was broken down into two categories: "avoidant", and "ambivalent". Avoidant children were those that did not protest the mother's departure from the room, nor did they seem too concerned with her return. Originally thought to be independent at a younger age, further studies showed that avoidant children had less success in school later in life. The ambivalent children were like a mix of the first two styles. The ambivalent attachment was represented by a child that protests the mother's departure from the room, and then welcomed her return; although these children would not calm down easily and would resist their mother's attempts to soothe them. Years later, Mary Main (a student of Ainsworth) would add a fourth category: "disorganized". Main believed disorganized children were a small percentage of children that were unclassifiable by Ainsworth's measure; generally, children that had traumatic and

inconsistent caregiver experiences. Main also expanded upon the attachment categories, looking at attachment in adults (Shilkret and Shilkret, 2008).

Adult styles: Main developed the Adult Attachment Interview (AAI) to assess attachment styles in adults and adolescents (Shilkret & Shilkret, 2008). The AAI measures an individual's caregiver system, versus the attachment system (Allen, 2008). Main qualified secure adults as those that have a clear, consistent, and succinct interpretation of their caregiver experience, and are not overwhelmed by emotions (Shilkret & Shilkret, 2008). These individuals may have had some trauma in their lives, although they are able to speak of the traumas in a cool and collected manner (Shilkret & Shilkret, 2008). Main believed the other two categories (avoidant and ambivalent) evolved into “dismissing” and “preoccupied” styles. Dismissive adults generally don't have a good recollection of their early childhood attachment experiences, minimize the importance of early attachments, and generally convey a shallow and inconsistent account of their childhood that may idealize their parents (Shilkret & Shilkret, 2008). This is different with preoccupied adults, who can not only recall, but brood about their childhood experiences without finding any resolution; in addition, they often resent their early caregivers (Shilkret & Shilkret, 2008). Main also had a small category that would represent the evolution of the disorganized attachment style which she referred to as "unresolved" or "disorganized" which referred to adults that showed such a great disorganization of thought in their accounts of early trauma (Shilkret & Shilkret, 2008). Other theorists had alternate versions of adult attachment that would take Main's assertions into account.

Kim Bartholomew (1990) would extend the four-category model of adult attachment, proposing that adult attachment is based on one's model of the self and one's model of others. Bartholomew's model: "...systematizes Bowlby's conception of internal working models by

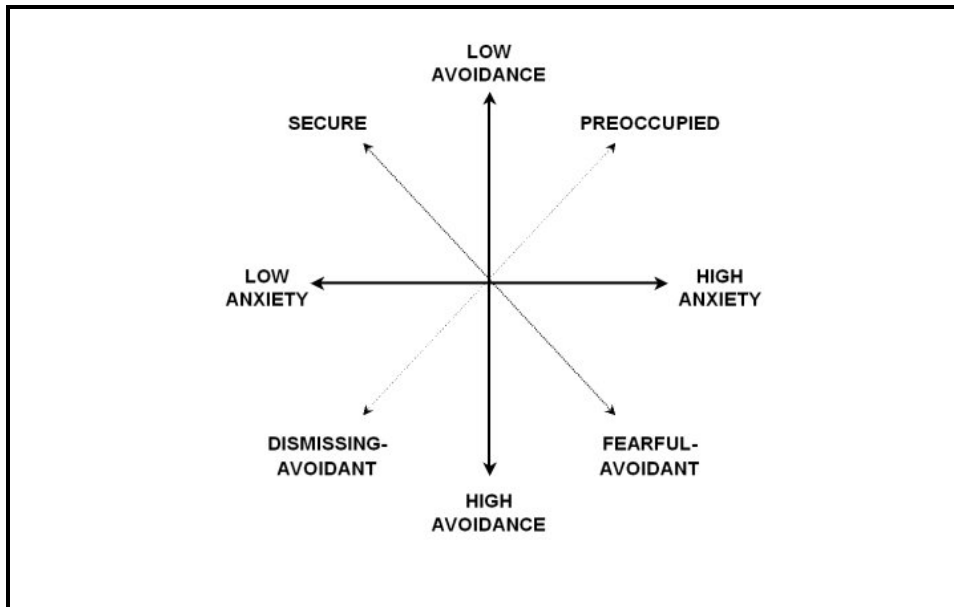

Figure 1. The two-dimensional model of individual differences in adult attachment.

Note. From "Self-Report Measures of Adult Attachment" by Shaver & Fraley, 1997, retrieved from <http://internal.psychology.illinois.edu/~rcfraley/measures/measures.html>

organizing different patterns of adult attachment in terms of the intersection of models of the self and other" (1990, p.162). Bartholomew's model is best organized in a grid (see figure 1).

The four-category model proposed by Bartholomew represented a shift in the perceived complexity of attachment styles. By distinguishing between one's model of self (worthy versus unworthy, of love and attention) and one's model of others (others are accepting, caring, and available; versus rejecting, uncaring, and distant), Bartholomew (1990) argued her model allows people to demonstrate more than one attachment style. Under Bartholomew's (1990) model, secure attachment is still synonymous with high-self esteem and low levels of significant interpersonal conflict. Bartholomew's (1990) preoccupied style is representative of dependant people who constantly seek out the approval of others while simultaneously feeling a deep sense of unworthiness. Preoccupied in this case corresponds to the ambivalent and preoccupied-

enmeshed styles identified in previous research (Bartholomew, 1990). The bottom half of her grid represents styles similar to avoidant behaviors. The fearful style represents those that experience frustration in terms of their attachment needs. They live with a constant sense of uncertainty as they desire social contact, but seek to distance themselves from intimacy (Bartholomew, 1990). These people have a constant distrust of others and invariably fear rejection (Bartholomew, 1990). And finally, the dismissive style described by Bartholomew (1990) corresponds to people whose attachment system has practically deactivated. People with this attachment style overly value self-sufficiency so much that they often sacrifice relationships with others for more impersonal aspects of life such as hobbies or work (Bartholomew, 1990). Since the evolution of attachment styles, theorists have gone into greater exploration of when, why, and how people develop various attachment styles.

Attachment in early childhood: One of the most important aspects of attachment theory is the concept of the “good-enough” caregiver. Attachment styles develop primarily during the first four years of life, and then get refined over the remainder of one's being (Marvin & Britner, 2008). But Ainsworth focused on the importance of these first few years where the youngster's ability to use the caregiver as a secure base are crucial to one's development. Marvin and Britner (2008) explain how the child's relationship with the caregiver changes at each point in development:

...attachment-caregiving interactions between the youngster and its attachment figure(s) compensate for and complement the lack of motor, communication, and social skills on the youngster's part, so the youngster is always protected while being afforded as much independence as possible within which to learn those skills. (p.271)

Bowlby postulated that human children went through four different phases, three of which happen in the first year of life, the fourth happening around the toddler's third birthday (Marvin & Britner, 2008). These are discussed in the following sections.

Developing attachment: The first year: An important tenet of Bowlby's work is his concept of the "internal working model" (IWM) (Marvin & Britner, 2008). Bowlby believed that humans had an innate capacity for forming sophisticated goal-corrected patterns of behavior that he dubbed IWMs. In the first year of life, babies and caregivers engage in interactions that are largely affectionate and predictable. During the first year, the IWMs are likely present but fairly primitive (Marvin & Britner, 2008), likely concerned with "on/off" behavior; that is, behavior that is correlated with starting and stopping of individual behaviors. During this phase, the caregiver monitors and maintains proximity to the infant (Marvin & Britner, 2008). Smiling and crying are the infants primary means of communicating, as they are establishing "internal and dyadic rhythms" with the caregiver (Marvin & Britner, 2008, p.276). Bowlby believed that after eight to 12 weeks (under favorable conditions), the infant would transition to a new phase of development that would occupy roughly the third through sixth months of life (Marvin & Britner, 2008).

In this second phase, the infant moves from a relationship with the caregiver where behavior activation and termination (on/off behaviors) was largely dictated by the caregiver, to one where the infant is gaining more autonomy over the starting and stopping of behaviors; as Marvin and Britner (2008) describe:

The primary focus here is on the control of the individual systems. Whereas in Phase I the caregiver provides the conditions for terminating one behavioral link

in a chain and activating the next, during Phase II the infant assumes much of this control. (p.276)

At this phase, the infant is starting to discriminate between the most familiar caregiver(s) and strangers, in addition to differentiating between various attachment behaviors (Marvin & Britner, 2008). Furthermore, infants at this phase being initiating attachment behavior, rather than passively responding to attachment behavior initiated by the caregiver (Marvin & Britner, 2008). Somewhere between six and nine months, the infant will enter a new phase of development.

In the third phase of development, the infant begins exhibiting more attachment behavior towards a single attachment figure in particular; Marvin & Britner (2008) posit: "...it is during phase III that most experts would consider the infant to be 'really' attached, due to organizational changes in behavior (p.277). At this point in the infant's development, there is a marked increase in locomotion, allowing for greater control of proximity to the caregiver (Marvin & Britner, 2008). In addition, the infant's cognitive capacity is increasing; Bowlby speculated that this is when infants begin forming a mental image of what it is they want, a "set goal" that they would like to achieve (Marvin & Britner, 2008, p278). Due to these newfound abilities, the infant's IWMs will adapt according to the particular need of the infant, the response of the caregiver, and the relationship history of the dyad (Marvin & Britner, 2008). Due to these increased liberties, the infant's exploratory system begins to develop, and a sociability and wariness system develop concurrently with it (Marvin & Britner, 2008) in that infants are both drawn to, and skeptical of strange people. Whether or not the person displays positive, non-intrusive affect, and mirror's the infant's own behavior will affect the infant's social interaction. Wariness considers the infant's survival based instincts toward novel, unexpected, and/or non-human events (Marvin &

Britner, 2008). The organization and implementation of these systems is what Ainsworth referred to as the "hallmark" of attachment (Marvin & Britner, 2008, p278).

Toddlerhood to preschool: As the child enters toddlerhood, they begin to refine their attachment behaviors. With their newfound abilities (locomotion, beginning of sound and word making), children between two and three years old have new ways of establishing proximity to their primary caregiver. When the caregiver stops paying attention, children tend to exhibit behavior what is often labeled "attention-seeking behavior" (Marvin & Britner, 2008). While this is generally viewed as regressive behavior, this is an adaptive method of the child seeking out its secure base; it isn't until about 3 years of age that the child begins experiencing less distress as a result of separations from the caregiver (Marvin & Britner, 2008).

Between the third and fourth year, the child's means of communicating begins to shift, as they will begin integrating into social groups with their peers (Marvin & Britner, 2008). These pre-school years are when children's IWMs begin shifting again as well. Children begin playing with others under a "shared-goal partnership" (Marvin & Britner, 2008). While it is between two and three years of age that children begin to realize that others have their own feelings and goals, it is near the fourth year that children begin to distinguish between their own perspectives, and the perspectives of others simultaneously (Marvin & Britner, 2008). Play in these relationships is marked by the child's increasing ability to play under the shared-goal partnership (Marvin & Britner, 2008). This is also when the youngster is becoming interested in integrating more about their surroundings, constantly asking "Why?" (Marvin & Britner, 2008). Soon after consolidating these skills, the child will move onto the fourth stage of attachment development.

In this fourth stage, the understanding of a partnership becomes increasingly important to the toddler. Here the child will begin to inhibit attachment behavior at times in favor of

incorporating the plan of the caregiver into the child's own plan for proximity, this is referred to as the "emergent partnership" (Marvin & Britner, 2008). In addition, the child begins operating on one's own plans, as well as the plans of the caregiver simultaneously, and having the ability to understand the causal relationship between the two (Marvin & Britner, 2008). As the child's ability to inhibit their own behavior increases, the child and caregiver should be able to affect each other's behavior (Marvin & Britner, 2008). This is important because it is demonstrating the emergence of true decision-making.

Within the fourth year, and assuming the child grew up in low-risk settings, there are five skills the child should attain: (a) the ability to recognize that the attachment figure possesses internal events (including thoughts, goals, plans, feelings, etc.); (b) the ability to distinguish between the caregiver's point of view and the child's own, especially when they differ; (c) the ability to infer, from logic and/or experience, what factors control the caregiver's goals and plans; (d) the ability to assess the degree of coordination, or match, between their respective points of view; and (e) the ability to influence the caregiver's goals and plans in a goal-corrected manner (Marvin & Britner, 2008, p.286). With the emergence of these skills, the child's goals become less about proximity to the caregiver, and more about the idea of a partnership with the caregiver with the ability to seek proximity in cases of need, this is referred to as the "goal-corrected partnership" (GCP) and is the last observable stage that one will go through (Marvin & Britner, 2008). Bowlby believed this was based upon: "(a) belief that lines of communication with the attachment figure are open, (b) that physical accessibility is possible, and (c) that the attachment figure will respond if called upon for help" (Bowlby, 1987, cited as personal communication by Ainsworth, 1990, p.474). While the fourth stage is the final stage that one passes through, an individual will continue to be affected by attachment relationships throughout their lifetime.

Elementary school through high school: The GCP still requires much research as to how it evolves into various attachment components; however, the general concept is fairly substantiated and represents an important bond between the parent and child as the parent is still responsible for the child's safety (Marvin & Britner, 2008). During the elementary years, the child's attachment behavior increasingly focuses on establishing an attachment system (versus physical proximity). During this time the child's relationship with the caregiver will change, and vice versa (Marvin & Britner, 2008). The child begins making other attachment relationships such as with teachers or siblings (Marvin & Britner, 2008). Then, in the transition from elementary to middle school, the child's social world moves from their parents to their peers (Kerns, 2008).

Much like a mother lion tending to her aging cubs, human parents begin to allow their children more autonomy as their age increases. Researchers posit that prior to this shift, parents are the responsible parties for their children; however, after the shift the parent-child dyad moves to a system of mutual co-regulation (Kerns, 2008). It is believed that at this time, the attachment goal moves to caregiver availability, and that successful transition into this phase is represented by a decline in both the frequency and the intensity of check-ins with the caregiver (Kerns, 2008). Youngsters in this phase are also beginning to evaluate and alter plans if necessary (Kerns, 2008). This shift in the attachment system is especially important for the youngster's next phase of life, adolescence.

In his explanation of the attachment system of adolescence, Allen (2008) succinctly explains the exciting advances in the teen's life:

...it is a period of profound *transformation* in emotional, cognitive, and behavioral systems surrounding attachment relationships, as the adolescent

evolves from being a receiver of care to becoming a self-sufficient adult and potential caregiver to peers, romantic partners, and offspring. (p.419)

Here the child is shifting their attachment system from their parents to their social world, primarily their peers. Allen (2008) posits that individuals pass an important marker at this time, as the attachment system can now be assessed in terms of a generalized organization within the individual, that is consistent, stable and can predict behaviors and functions within and outside of the family system. Researchers believe teens make this progression based on their increasing ability for formal operational thinking that develops during these years, allowing teens to think about attachment in a more general way (both positive and negative) across multiple relationships (Allen, 2008). This decreased reliance on parents and the increased operational thinking, creates an impetus for both parent and teens to alter their attachment behaviors to meet the evolving needs of the teenager (Allen, 2008). The teenager requires refinement of their negotiation skills (versus the coordinated effort they utilized in earlier years); parents need to allow their teen to explore the world, and even make mistakes, so that the teen can successfully navigate the adult world (Allen, 2008). This is a difficult phase for the teen, as they experience a distressing phase, similar to toddlerhood, where they want to differentiate themselves from the parent, yet they don't want to lose the parent as a secure base in times of need. As the attachment system moves from the teen's parents to their peers, romantic exploration becomes more important to the teen (Allen, 2008).

As the teen begins to transfer their attachment needs from parents to peers, parsing out which attachment relationships are most important becomes increasingly difficult. Ainsworth cited five characteristics that differentiate attachment relationships: proximity seeking, distress upon inexplicable separation, pleasure or joy upon reunion, grief at loss, and secure behavior

(referring to the ability to explore and/or converse more freely in the presence of the attachment figure; Allen, 2008). Allen (2008) avows the importance of romantic relationships as one explores what rewards they have to offer, and that by mid-adolescence the teen's romantic relationships may well reflect all five of Ainsworth's criteria for attachment. Meanwhile, the parent-child relationship continues to evolve.

Allen (2008) declares the importance of the evolution of the GCP in adolescence as both parties need to be able to allow for teen exploration while maintaining the respect in the relationship. Allen (2008) states:

For such a partnership to be successful, however, two key ingredients are required: a strong capacity to communicate across the increasingly divergent perspectives and needs of the parent and teen, and a willingness among both parties to allow the adolescent to seek autonomy while maintaining the parent-teen relationship. (p.424)

The ability of both the parent and child to navigate this transition may affect the child's future attachment. Theorists posit that a securely attached teen will handle conflict through discussion and trouble-shooting, while an insecure attachment comes from dynamics that smother the child such as arguing or conversing too much so that the child's independence is ultimately stifled (Allen, 2008). Family interactions can also alter a teen's attachment style, as is the case of teens with mothers that enact enmeshed behavior between the ages of 16 and 18, a common behavior for insecure-preoccupied mothers (Allen, 2008). While this information is still emerging, researchers are starting to discover certain predictive patterns.

Researchers are discovering that attachment organization in adolescence is also linked with their mental health. Initial research findings suggest certain behavioral displays are more likely to lead to internalizing or externalizing behavior, as Allen (2008) summarizes:

Although the pattern is not yet well established, the initial research findings collectively suggest that when preoccupied adolescents are exposed to passivity or enmeshment, an internalizing, anxious/depressed pattern emerges; however, in situations where their attachment entreaties are likely to be ignored or rebuffed, they are likely to react with externalizing behavior. (p.428)

Similar to the attachment transition during toddlerhood, attention-seeking behavior becomes a result of misattunement between the parent and teen. In toddlerhood, the attachment seeking behavior is representative of the child's need for proximity; whereas with a teen, the attachment seeking behavior is representative of the teen's complex, perceived need for both autonomy and/or emotional support. Researchers see the preoccupied teen's attachment system as being hyperactivated in response to their social world, making them more sensitive to social interactions (Allen, 2008).

Given their sensitivity, the internalizing behaviors may represent an active caregiver-seeking process, that when ignored may have the teen believe that they need to increase the intensity of their behaviors, making for a more dramatic response (Allen, 2008). Although this hyperactivated attachment system is problematic at times, it also serves to bring the teen into positive social relationships that the teen may be responsive to (Allen, 2008). However, the dismissing teen's strategies tend to focus on distracting behavior that obfuscates attachment-related cues from themselves and others (Allen, 2008). Dismissive teens tend to turn to substance abuse and conduct disorder as stress management strategies (Allen, 2008).

Additionally, these teens are less likely to enlist help from peers or teachers, and are more likely to withdraw socially during the transition from high school to college (Allen, 2008). In addition to enmeshment, there are other factors that may foster an insecure attachment in a teenager.

Environments that foster stress of the child's social and intrapsychic world can lead to insecure attachment (Allen, 2008). Allen (2008) summarizes:

These environments include poverty (which stresses adolescents while draining parents), adolescent depression (a difficult-to-soothe form of distress), and emotional enmeshment (which stresses adolescents while making them want to avoid seeking comfort from a parental figure). Together, these factors account for substantial variance in the change in security during adolescence. (p.430)

This demonstrates the tenuous nature of attachments throughout one's life. While we have a breadth of knowledge about attachment past four years, of age, there is still a lot of research to be done on how attachment stabilizes or is influenced to shift over the course of one's life.

Research limitations: Kern (2008) points out that much of the theory regarding middle childhood faces some limitations. She underscores that much of the research that theory is based upon uses different measures and definitions of attachment (Kern, 2008). Kern (2008) stresses the importance of studies that would incorporate multiple measures across the same subjects so as to assess the validity of various measures currently in practice. Allen (2008) describes some of the limitations of our current theory regarding adolescents; the most notable being our lack of knowledge regarding the actual quality of attachments that adolescents form. He recommends researchers focus on expanding and growing the current view of the attachment system so as to reflect our knowledge of the increasing complexities inherent in adolescent attachment.

Attachment and Technology

It is interesting to note the discrepancy between technological purpose and attachment needs. New screen-technology designed for youngsters occupies the child, but does not serve the attachment need of proximity. When one examines the list of the top educational iPhone apps, the apps are often described as being perfect for children between the ages of two to six. An important time developmentally as discussed by Marvin and Britner (2008), these are important ages in going from understanding one's influence upon other people as well as discovering the function of various attachment behaviors. When left to learn by way of a smart phone (versus a parent interactively teaching a child), what gets lost? Before answering such a question, it is necessary to explore what we are physiologically talking about when we talk about attachment: the brain.

The Human Brain & Attachment

In their book *A General Theory of Love*, Lewis et al. (2000) describe several processes that may be interrupted by technology in their exploration of the brain's purpose and anatomy. The brain is comprised of three relevant regions: The brain stem, the limbic brain, and the neocortical brain.

This survival-based portion of our brain, also referred to as the "reptilian brain", is the center for basic unconscious processes (breathing, heart rate, regulating body temperature, etc.), instinctual memories, and one's predisposition for worrying (Cozolino, 2010; Lewis et al., 2000). The culmination of these processes produces a basic behavioral framework and a temperament that isn't easily swayed, except through emotional influence (Lewis, et al., 2000).

The section between the brainstem and the cortex is referred to as the limbic brain. Cozolino (2010) references the limbic brain as being concerned with learning, motivation,

memory, and emotion; the amygdala (attachment, appraisal of expression) and the hippocampus (organizes explicit memory, modulates emotional relative to circumstance and coordinates with the cortex) are two pieces of the limbic system that are especially relevant to psychology. Lewis et al. (2000) eloquently discuss the limbic system's purpose:

The primordial purpose of the limbic brain was to monitor the external world and the internal bodily environment, and to orchestrate their congruence. What one sees, hears, feels, and smells is fed into the limbic brain, and so is data about body temperature, blood pressure, heart rate, digestive processes, and scores of other somatic parameters. The limbic brain stands at the convergence of these two information streams; it coordinates them and fine-tunes physiology to prime the body for the outside world. (pp. 51-52)

Here, Lewis et al. is referring to the ability of the limbic brain to modulate the reptilian brain as well as the neocortical.

The neocortical brain refers to the outer layer of the brain. This part of the brain was the last (or the most recent depending on how you look at it) to develop in terms of our evolution and is involved in many of the processes that distinguish humans from other mammals such as language, problem-solving, and mathematics (Lewis et al., 2000). Two especially important areas relative to language are "Broca's area" and "Wernicke's area". Broca's area is responsible for translating thoughts into words, while Wernicke's area is responsible for interpreting words that are heard and making meaning of them (Lewis et al., 2000). However, inherent in this advanced cognitive function, is the dilemma of how to execute so many functions within the brain.

Communicating without words: The brain distributes some functions across structures, for instance: while the expression and interpretation of emotion is the task of the limbic brain, talking about emotion is the duty of the neo-cortex. With two divergent functions, the brain developed "prosody" as a way of reconciling the dichotomous brain functions. Prosody is an inflection on a word or phrase that adds an emotional layer to what's being said. Cozolino (2010) discusses the importance of prosody at birth; what's being said to a newborn is relatively meaningless hours after birth, but the tone and inflection with which one speaks is being integrated into the infant's brain. Prosody remains relative throughout one's lifetime as Lewis et al. (2000) elucidate, purporting that anyone who has communicated with a teenager will know that single word responses (such as "yeah" or "sure") can have a variety of meanings based on the prosody inflected by the teenager. This ability for the brains to communicate additional layers without language is important in the context of infancy more than ever because of an infant's lack of vernacular.

Limbic resonance is the phenomenon of speaking through facial and bodily expression alone. Lewis et al. (2000) describe this phenomenon as a sort of neural attunement: "...a symphony of mutual exchange and internal adaptation whereby two mammals become attuned to each other's inner states. It is limbic resonance that makes looking into the face of another emotionally responsive creature a multi-layered experience" (p.63). An important phenomenon, limbic resonance is especially important for a mother and her infant, as the infant's brain will learn to sync accordingly with the mother's through limbic resonance; Cozolino (2010) explains:

A mother reflexively holds her baby against her body after birth, maximizing skin contact and helping the infant's hypothalamus establish a set point for temperature

regulation. The infant and mother gaze into each other's eyes, linking their hearts and brains... (p.183)

The process of limbic resonance lays the groundwork for future personal processes.

Self-soothing: Bowlby himself indirectly hypothesized about the importance of prosody and limbic resonance:

...infants respond and need the physical proximity of a caring and attuned parent to develop a sense of security and safety. The combination of physical proximity and emotional attunement act as a buffer protecting the developing child from feeling alone and unwanted in the vast and uncertain world. (Goldstein & Thau, 2011, p.65)

Goldstein and Thau (2011) go on to reiterate that this is the most basic way that infants learn about the world, and how an attuned, non-distressed caregiver will likely transmit those feelings to the infant's nervous system. However, much to the chagrin of many parents, the opposite can happen as well:

Intense emotionality triggers the limbic system (specifically the amygdala) to be alert and to signal the sympathetic nervous system's response of flight or fight; either response creates arousal, and this arousal has the potential to permanently alter the developing child's delicate nervous system. (Goldstein & Thau, 2011, p.66)

This is a similar phenomenon described by Allen (2008) in teenagers that when exposed to enmeshment, teenagers are more likely to adopt insecure attachments behaviors, specifically internalizing behaviors. Goldstein and Thau (2011) elaborate on these effects in infants, a by-product of limbic resonance, "vagal tone" is the resulting groundwork laid

by emotional transmission, whereby the infant learns to self-regulate. In order for the infant to be able to utilize and hone this skill effectively, they must be able to seek out both care and the regulatory capacity of another person so as to achieve mutual regulation (Goldstein & Thau, 2011). One may recognize this from earlier discussion, as this is one of the hallmark behaviors of a securely attached infant. Much like the effect enmeshment can have on teenagers, Goldstein and Thau (2011) explain how technology can foster insecure attachments:

In this age of technology, intrusive parents may "check on" children by e-mail, cell phone, text messages, and global positioning systems (GPSs), which track children who drive. They may require that their children call them several times daily and report on their every move. (p.70)

They illustrate a common belief among these types of parents: "... their 'helpless' children must be protected against experiences of failure and unfairness in life" (Goldstein & Thau, 2011, p.70). When parents remove common obstacles in a child or teenager's life, the opportunity to learn how to self-soothe is lost. Self-soothing is a coping skill that is often foregone in individuals with insecure attachments, a common response to this skills deficit is drug abuse.

Drug abuse, addiction, and technology: Unfortunately, the idea of studying technology as a whole is novel to the field of addictions. Many of the articles that I read used internet use and/or video games as the baseline behavior for their research on what I'm referring to as technology addiction (Dong et al., 2011; Gentile, 2009; Gentile et al., 2011; Han et al., 2011; Han, Kim, Lee, & Renshaw, 2012; Han, Lyoo, & Renshaw, 2012; Holtz & Appel, 2011; Hou et al., 2012; Kim et al., 2011; Ko et al., 2009; Kuss, van Rooij, Shorter, Griffiths, & van de Mheen, 2013; Liu & Kuo, 2007; Siomos et al., 2012; Small, Moody, Siddarth, & Booker, 2009; Tsai et

Table 1. Proposed internet addiction diagnostic criteria.

(a) Symptom criterion

All the following must be present:

Preoccupation with the internet (thinks about previous online activity or anticipates next online session)

Withdrawal, as manifested by a dysphoric mood, anxiety, irritability and boredom after several days without internet activity

At least one (or more) of the following:

Tolerance, marked increase in internet use required to achieve satisfaction

Persistent desire and/or unsuccessful attempts to control, cut back or discontinue internet use

Continued excessive use of internet despite knowledge of having a persistent or recurrent physical or psychological problem likely

to have been caused or exacerbated by internet use

Loss of interests, previous hobbies, entertainment as a direct result of, and with the exception of, internet use

Uses the internet to escape or relieve a dysphoric mood (e.g. feelings of helplessness, guilt, anxiety)

(b) Exclusion criterion

Excessive internet use is not better accounted for by psychotic disorders or bipolar I disorder

(c) Clinically significant impairment criterion

Functional impairments (reduced social, academic, working ability), including loss of a significant relationship, job, educational or career opportunities

(d) Course criterion

Duration of internet addiction must have lasted for an excess of 3 months, with at least 6 hours of internet usage (non-business/non-academic) per day

Note. From "Proposed Criteria for Internet Addiction" by Tao, Huang, Wang, Zhang, and Li, 2010, *Addiction*, 105(3). 556-564.

al., 2009; van Eijnden, Spijkerman, Vermulst, van Rooij, & Engels, 2010; Whang, Lee, & Chang, 2003; Yen, Yen, Chen, Chen, & Ko, 2007; Zhou et al., 2011). It still remains to be seen whether or not the field will choose to recognize Internet Addiction Disorder (IAD) as a diagnosis, but for the purposes of this study, IAD will be referred to as it is currently being conceptualized (indicated in Table 1). Much like other addictions, the criteria for internet

addiction includes markers such as withdrawal, failed efforts at controlling use, and negative effects on life due to use of the addictive medium. Also similar to other addictions, similar brain regions are implicated in IAD.

This is Your Brain on Drugs

In their exploration of the regions of the brain that have been implicated in addiction research, Green and Ostrander (2009) suggest five regions of the brain identified as being crucial to the manifestation of addiction: the nucleus accumbens (NAc), the ventral tegmental area (VTA), the hippocampus, the prefrontal cortex (PFC), and the amygdala. The authors also suggest that the insula and the anterior cingulate cortex (ACC) have been implicated in addiction pathways in the brain (Green & Ostrander, 2009); for the purpose of this review, the first five regions and the ACC will be focused on. Although it isn't included in Green & Ostrander's work, the caudate nucleus (CdN) will also be discussed due to its appearance in IAD research (Han et al., 2012; Kim et al., 2011; Ko et al., 2009). General location of said regions of interest can be found in figure 2 and figure 3.

Nucleus accumbens and ventral tegmental area: Interestingly enough, the effects of all drug abuse end in the NAc (Green & Ostrander, 2009). Composed of two parts, the inner core and the outer shell, the NAc is involved in a variety of actions (Green & Ostrander, 2009). The shell is directly involved with limbic and emotional functions, while its counterpart, the core, is implicated in motor functioning and learning (Green & Ostrander, 2009). The NAc houses a specific type of neuron called a "medium spiny neuron" (MSN; Green & Ostrander, 2009). MSNs play a role across various stages of addiction (including first time and chronic use) and it is important to note that their function may be inhibited by the VTA (by way of dopamine

release, Green & Ostrander, 2009). The VTA's ability to inhibit MSNs is especially important because of the NAc's connection (through other areas of the brain) and influence on the PFC.

Prefrontal cortex: One of the larger areas of the brain, the PFC is linked to many important day-to-day functions. The PFC is responsible for regulating affect and attachment, as well as coalescing cognitive and motor behaviors (Cozolino, 2010). The PFC is also responsible for higher order thought processes such as metacognition (our ability to reflect upon our own thoughts and memories), problem solving, and tracking social interactions (Cozolino, 2010). Because of its size, the PFC is typically broken down into smaller regions when discussing functions: the dorsolateral PFC (DLPFC), and the orbitomedial PFC (OMPFC).

Dorsolateral prefrontal cortex. The DLPFC specializes in "attentional" information, organizing the information it receives from our senses, body, and memory (Cozolino, 2010). Additionally, it performs several functions including focusing attention, organizing working memory, learning motor sequences, evaluating environmental contexts, and prediction

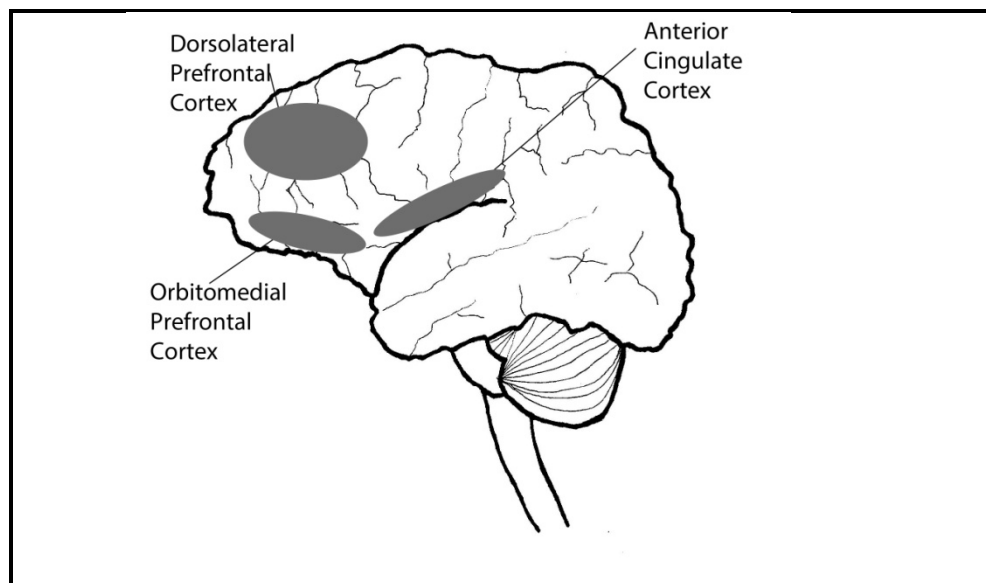

Figure 2. The two regions of the prefrontal cortex (dorsolateral and orbitomedial) and the anterior cingulate cortex.

(Cozolino, 2010). The DLPFC doesn't experience much growth until the acquisition of language and the ability to explore physical and conceptual worlds, but then DLPFC growth persists into the third decade of life (Cozolino, 2010). Green and Ostrander (2009) specifically cite the DLPFC as not thought to be involved in addiction (p.181), yet it intriguingly appears as an important part of the brain in several studies examining IAD. The DLPFC and OMPFC work in concert in contributing to what's referred to as "top-down" processing, whereby both areas rely on the other's functioning in the interest of their own optimal functioning. For instance, a hyperactive OMPFC will interrupt the DLPFC's ability to process information resulting in poor concentration; conversely, a hyperactive DLPFC will likely exhaust the OMPFC and result in emotional instability due to the OMPFC's dense connection to the amygdala.

Orbitomedial prefrontal cortex. The OMPFC develops before the DLPFC, during the first 18 months of life (Cozolino, 2010). The OMPFC processes "affective" information and is appropriately situated atop the limbic system. It is densely connected to brain circuits involved in learning, memory, and cognition. Additionally, the OMPFC is tasked with organizing interpersonal relationships, appraisal of complex social events, and calculating reward-punishment values (Cozolino, 2010). The OMPFC is comprised of two parts, the orbitofrontal (OFPFC) and medial PFC (MPFC). Behavior as a result of damage to the OMPFC is similar to common drug-seeking behaviors.

Despite shifting and/or reinforcing conditions, an animal with damage to its MPFC will have difficulty changing maladaptive behavior (Green & Ostrander, 2009). Much like the common recovery adage goes: the definition of insanity is doing the same thing over and over again, but expecting different results. Similarly, damage to the OFPFC results in compulsive reward-seeking even in spite of negative consequences (Green & Ostrander, 2009). This is similar to an

alcoholic getting their fifth DUI despite possible legal, occupational, and medical ramifications. The OMPFC adjoins to two other important areas of the brain: the ACC and the amygdala.

Anterior cingulate cortex. The ACC is a limbic structure connected with several parts of the brain: the OFPFC, amygdala, NAc, hypothalamus, and hippocampus; due to these connections, the ACC is thought to be affiliated with exhibition of emotional, motivational, and neuro-vegetative functions (Green & Ostrander, 2009). Neuro-vegetative function refers to a general disconnection with society and/or isolation, a common behavioral trait in IAD clients. Furthermore, Cozolino (2010) posits attachment based functions that the ACC is purported to be involved in from as early as two months of life: caretaking, resonance, cooperation, and empathy all have their roots in the ACC. This is especially important to this research as children are using technology as early as the first year of life.

Amygdala: The amygdala is a limbic structure that is thought to be the home of the

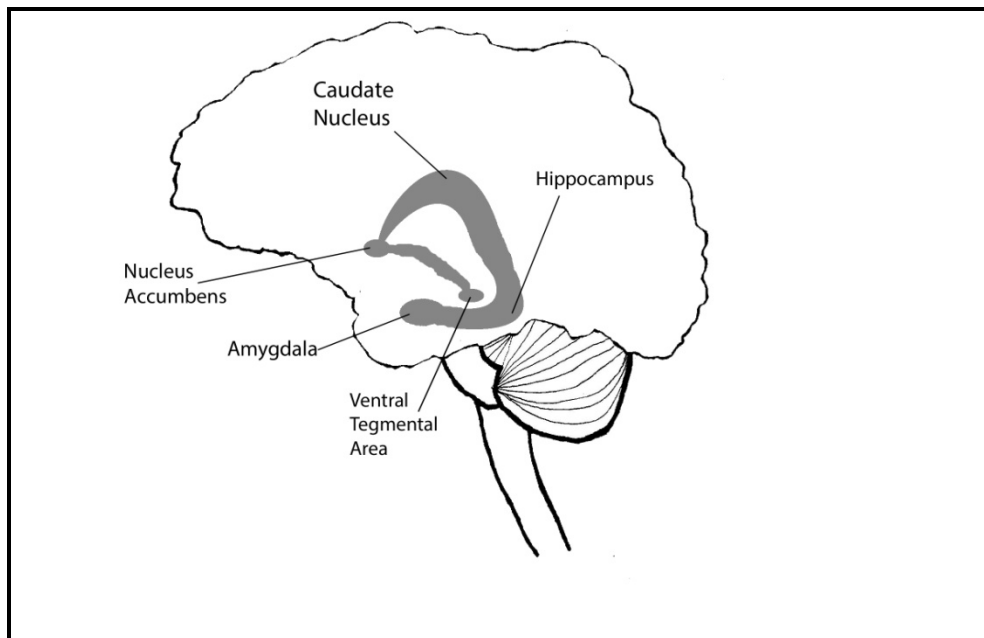

Figure 3. Noted areas of the limbic system: the ventral tegmental area, amygdala, nucleus accumbens, caudate nucleus, and the hippocampus.

human attachment system, and the center of both emotional and physical pain (Cozolino, 2010).

It is often conceptualized in two parts: the basolateral complex (BIC) and the central nuclei (Green & Ostrander, 2009). By way of the NAc and the lateral hypothalamus, the BIC is thought to influence and inhibit appetitive drives (Green & Ostrander, 2009). Green and Ostrander (2009) suggest that research underscores another important function of the BIC:

Everitt and Robbins (2005) suggest that the basolateral complex has some involvement in creating the stimulus-reward associations that may contribute to drug seeking and relapse in drug addiction, as well as being critical to the representation and transfer of information about the motivational value of conditioned stimuli to instrumental motor learning (Jentsch & Taylor, 1999).

(pp.181-182)

Cozolino (2010) asserts that the amygdala's role is to constantly assess our environment for any indications of danger so that it may activate our fight or flight response if necessary. He also points out that the OMPFC can inhibit the amygdala based on the information it is evaluating in response to the environment. Therefore, a person with an overactive amygdala would likely be looking for ways to calm themselves. If their OMPFC isn't up to the task, then another component in one's ability to modulate affective arousal is the hippocampus.

Hippocampus: The hippocampus is also an important limbic structure relative to addiction, as it effectively counterbalances the amygdala. According to Cozolino (2010) the hippocampus: "...organizes explicit memory and the contextual modulation of emotion in collaboration with the cerebral cortex" (p.60). This makes the hippocampus the logical part of the limbic system, meaning that decreased hippocampal functioning would lead to greater emotional influence from the amygdala in terms of guiding one's memory, emotion, and behavior

(Cozolino, 2010). Cozolino postulates: "Put another way, the amygdala has a central role in the emotional and somatic organization of experience, whereas the hippocampus is vital for conscious, logical, and cooperative social functioning" (p.85).

The hippocampus interprets loads of sensory information in relation to a drug. It will keep an inventory of both the context and cues by which a drug (or other reward) was used (Green & Ostrander, 2009). It is tracking things such as the locale, the conditions, and other sensory information relevant to drug use. The hippocampus projects glutamatergic efferents (energetic output) onto the NAc, that in turn create synaptic connection to MSNs and dopamine neurons in the VTA (Green & Ostrander, 2009). This is like saying the brain is building bridges between the aforementioned structures; but it's not just building bridges, it's also making sure there are some fast lanes for the MSNs and dopamine. Without this hippocampal input, the PFC's attempt to influence MSN firing will fail (Green & Ostrander, 2009). Damage to the hippocampus has a cascading effect (refer to figure 2): A damaged hippocampus will lose its excitatory effect on the PFC, this in turn suppresses excitatory effects of the PFC on the NAc, this results in inhibition of MSN firing (Green & Ostrander, 2009). In addition, a diminished hippocampus has been linked to a weakened ability to transfer information from short- to long-term memory, as well as a lower ability to mitigate psychological trauma (Cozolino, 2010).

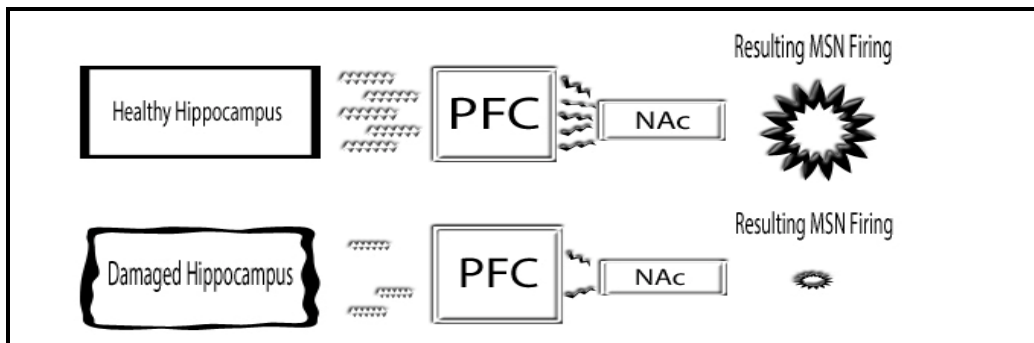

Figure 4. Medium spiny neuron firing relative to damage inflicted to the hippocampus.

Research demonstrates that drug use can be harmful to both hippocampal influence and volume (Green & Ostrander, 2009).

Caudate Nucleus: Along with the thalamus and the globus pallidus, Cozolino (2010), speculates that the CdN is part of the brain that reinforces obsessive-compulsive behaviors in tandem with the OMPFC:

It is hypothesized that the ompfc, or some other component of the OCD circuit, activates the circuit with a worry signal, decreasing inhibition of the thalamus, which in turn excites the ompfc and caudate (Baxter et al. 1992). The result is a feedback loop that is highly resistant to inhibition or shutting down. (pp.345-346)

It is interesting to see how this reluctance to quit using a drug can turn into a steadfast unwillingness to quit in cases of addiction. This reluctance was tragically observed March 24th when a 13 year old shot, and then attempted to rape, his mother after she took away his games as a result of his poor academic performance (Quigley & Farberov, 2013).

This is Your Brain on the Internet

"I'm not joking at all. She's dead. I'm scared. I killed my mom with my .22. I don't know why I did it" (Quigley & Farberov, 2013, paragraph 3). Unfortunately this isn't the only recent story linking IAD to adversity: The shooter of the Newtown, Connecticut tragedy had reportedly spent thousands of dollars on video games (Altimari, Mahony, & Lender, 2013), and a shooter in New Mexico murdered his family members and used his time with police officers to boast about his love for violent video games (Connor, 2013). Stories such as these make understanding IAD more important than ever.

Comparable to other behavioral addictions such as gambling, IAD does not have an active drug affecting the individual. Instead, repeated rewarding activities generate biochemical

changes in the body (Kuss & Griffiths, 2012). While research on IAD is still in its infancy, there has been some promising recognition by the American Psychological Association (2013) to consider "internet gaming disorder" a condition requiring further research. Much of the current research regarding IAD uses video-game-use as a primary criteria for inclusion and exclusion criteria (Dong et al., 2011; Gentile, 2009; Gentile et al., 2011; Han et al., 2011; Han et al., 2012; Han et al., 2012; Holtz & Appel, 2011; Hou et al., 2012; Kim et al., 2011; Ko et al., 2009; Kuss, et al. , 2013; Liu & Kuo, 2007; Siomos et al., 2012; Small et al., 2009; Tsai et al., 2009; van Eijnden et al. , 2010; Whang et al., 2003; Yen et al., 2007; Zhou et al., 2011). IAD research has produced some interesting findings.

In their exploration of which regions of the brain are involved in video game craving, Ko et al. (2009) found research that suggests the DLPFC (along with the NaC, amygdala, striatum, ACC, and OFPFC) is affected by cues that stimulate drug craving, and that the hippocampus, insula, and CdN were implicated in cues inducing food cravings. Ko et al. hypothesized that similar brain regions would be involved in IAD. Researchers tested 10 men with IAD against 10 male controls using a magnetic resonance imaging technique called echo planar imaging. The study design comprised of showing participants a series of images, including images of a popular video game. The results confirmed the researcher's hypothesis: the gaming group did in fact have a higher level of gaming urge and similar areas of the brain (akin to substance craving) were implicated in this finding. Brain regions of interest included the right OFPFC, bilateral ACC and MPFC, right DLPFC, as well as the right NAc and the CdN. Ko et al. concluded that along with its role in craving (in both cases of substance and behavior addiction), the DLPFC gets activated with the gaming cues by generating previous gaming experiences. This may help explain the obsession that addicts encounter, since their working memory becomes occupied by

the previous-experience response. The CdN's role comes in response to the DLPFC's activation. This study suggests that the CdN takes note of the activated DLPFC after the process has been repeated, habituating the brain to this process. Other manifestations inherent in IAD are discussed in other studies.

In their research exploring differences in gray matter volume, Han, Lyoo, and Renshaw (2012) explore how regions of the brain vary between professional gamers, problematic gamers, and casual gamers. Examining the brains of 17 professional gamers, 20 problematic gamers, and 18 casual gamers using magnetic resonance imaging (MRI), Han et al. found significant differences between the three. The ACC gray matter volume in problematic gamers was significantly smaller than the ACC in professionals, interestingly enough the reduced ACC was localized to the left ACC. Han et al. figured lateralization was due to the fact that the left side of the brain is associated with verbal working memory, whereas the right side is related to spatial memory. They attribute the decrease in size to the regimented and structured lifestyle of the pro-gamers, which Han et al. compared to training mentally and physically like professional athletes. In both problematic and professional gamers, gray matter volume in the occipital (primary visual cortex) and inferior regions of the temporal lobe were reduced when compared to the casual gamers. Han et al. hypothesized the diminishing effect on this portion of the brain was due to inordinate amounts of visual stimulation. Han et al. also correlate that IAD is mostly reported by teenage boys, and that these adolescent years are crucial for maturation of the visual cortex. Finally, Han et al. found that gray matter volume of the hypothalamus was positively correlated with higher scores on the Young Internet Addiction Scale (used for assessing IAD). Han et al. posit: "The thalamus is a key target for dopamine and plays a major role in conditioned reinforcement and reward expectation" (p.513). They believe this higher dopamine level

contributes to a labile mesolimbic brain region, which supports the rewarding effects of online gaming. Dopamine hasn't been discussed up until this point, but don't let that temper its importance in this neurological quagmire.

Implicated in reward systems, mood, and motor functioning, dopamine is essential to most discussions of mental health (Cozolino, 2010). Two studies have found diminishing effects of dopamine in internet addicted individuals: Kim et al. in 2011; and Hou et al. in 2012.

Following the literature on IAD's relation to substance abuse, Kim et al. (2011) suspected people with IAD would have reduced dopaminergic receptors available in the striatal regions of their brains (a reduction in dopamine receptor availability typically leads to increased thrill seeking, stimulation, and/or excitement). With a small sample of 12 men (five with IAD, seven controls), researchers utilized positron emission tomography (PET) to scan subjects' brains. Kim et al. found that participants with IAD had less dopaminergic receptor availability than controls, the degree of which was inversely correlated with level of IAD. Because of rigorous inclusion criteria, this study had an especially small sample, however the findings gave Hou et al. (2012) a thread to follow.

Exploring a similar realm of IAD, Hou et al. (2012) researched whether one's available striatal dopamine transporters effects the development of IAD. Responsible for facilitating dopamine reuptake, striatal dopamine transporters are responsible for regulating dopamine levels in the synaptic terminals. One can imply that people with a reduced level of dopamine transporters experience a greater "high" when they take part in pleasurable activities since there is less help in managing dopamine levels. This is problematic for addictive behavior because it makes the behavior more desirable by the brain. Five randomly selected men (all seeking treatment) that used the internet nearly every day (for non-work purposes) for eight or more

hours a day, were recruited into the IAD group; there were nine age matched controls. Researchers injected participants with a solution that engages their dopamine transporters and examined the brain regions of interest with imaging technology. Hou et al. found that participants with IAD had abnormal patterns of the dopamine transporters, containing smaller, less organized throngs of dopamine transporters. Hou et al. speculate that this pattern (also found in substance abuse patients) may represent brain impairment engendered by their IAD. Taken together, these studies suggest that those with IAD may experience a greater high when playing games; but like drug abuse, have a reduction in dopamine availability relative to the length of time they've met criteria for IAD. Much like the Kim et al. (2011) research, the Hou et al. (2012) research was limited by its sample size, therefore more research will be needed to bolster these findings. Nonetheless, numerous other studies have found results relevant to this research.

Technology: Plugging in, or disconnecting? In his book *iDisorder*, Larry Rosen (2012) explores the effects of technology across various facets of life. He covers an expansive array of concerning behaviors that carry attachment implications as well. Like the studies described above, his research demonstrates how excessive dependence on technology can lead to an

Table 2. Five features of technology that effect conversation.

-
1. They are simple and easy to use.
 2. They Exploit our senses by drawing us toward their appealing and entrancing brilliant visual displays and crystal clear sounds.
 3. They make us feel as though we are anonymous since nobody can see us.
 4. They exploit the fact that any communication without physical cues allows us to feel unencumbered and unconcerned about the impact we are having on the human being receiving our message.
 5. They are *always* available through many devices.
-

Note. From *iDisorder* p.9, by Larry Rosen, 2012, New York, NY: Palgrave Macmillan.

assortment of various maladaptive behaviors, especially behaviors regarding communication. Rosen lists five features of "e-communication technology" that impact conversation (listed in Table 2).

Each of these facets have attachment implications. E-technology's simplicity leads to repeated use, and is often a preferred method of communication for many, but that isn't to declare complete hegemony. In their surveying of 334 people under the age of 25, Farber, Shafron, Hamadani, Wald, and Nitzburg (2012) found that face-to-face communication was the preferred method of communication, along with texting. Farber et al. note that the convenience and appeal of these mobile devices has allowed young people to communicate while reducing emotional flow of a conversation. Whether or not this is a good thing is debatable. Farber et al. also note that those surveyed reported using their status updates on sites like Facebook for superficial and positive posts; the result of this culture is that those with low self-esteem viewing these posts feel increasingly like outcasts. Users are rewarded for temporarily displaying their positivity, despite whatever feelings may be existing within them. This scenario is uncannily similar to an alcoholic that receives praise for being "the life of the party", reinforcing the use of alcohol despite the uncomfortable feelings they may be harboring. Video games, one of the crowning examples of technological display, provide an example of why people are drawn to technology.

In a study by Han et al. (2011), researchers explored Rosen's second tenet regarding the allure of technology. Han et al. hypothesized that specific areas of the brain would be activated when presented with gaming-cues, specifically the DLPFC, OFPFC, amygdala, hippocampus, and the thalamus. Han et al. recruited 19 male college students who used the internet, but didn't meet criteria for IAD. They took a baseline functional MRI (fMRI) of each participant's brain, then taught these young men how to play a novel first-person-shooter game. Participants were

then instructed to play the game at least 60 minutes per day for the next 10 days, at the end of 10 days another fMRI was obtained while participants watched game play. Desire for game play was also assessed using a self-report. Researchers discovered a disparity in playing time between the two groups, therefore separated them into a group of gamers (6), and casual players (13); there were noticeable disparities in brain activity between the two groups. Han et al. report: "The present findings suggest that the neural circuitry that mediates cue-induced desire for Internet [sic] video game play is similar to that observed following cue presentation to individuals with substance dependence or pathologic gambling" (pp. 92-93). They found that the DLPFC, OFPFC, parahippocampal gyrus, and the thalamus to be connected to game-play desire. Han et al. speculate that the DLPFC remembers past experiences of positive game play (leading to increased reward-seeking behavior), and that the hypersensitive OFPFC in the gaming group represent systems akin to those seen in drug-addiction. In addition, the dopamine reward system was implicated in the increased activity of the parahippocampal gyrus and the thalamus; suggested to be associated with craving, Han et al. believed these structures didn't activate independently of the amygdala, but rather activated as a function of an emotionally aroused amygdala. This study demonstrates how the brain can be wired rather quickly (over a period of 10 days) to reward itself for technology-related behaviors.

Unfortunately, all e-technology-related behavior doesn't merely effect one person. Rosen's third facet regarding the anonymity e-technology affords us is cornerstone to toxic behavior that spreads on the internet (his fourth facet). In their research examining the effects of anonymity, Lapidot-Lefler & Barak (2012) expand their exploration beyond just "namelessness", and include eye-contact. Lapidot-Lefler & Barak's (2012) research is based on "disinhibition", a phenomenon Rosen is purporting in his third assertion. Lapidot-Lefler & Barak (2012) explain:

"The negative online disinhibition effect is the concept used to refer to the negative results of this loss of inhibitions, usually manifested in aggressive behaviors that apparently would not be exhibited in a similar scenario in the 'real world'" (p. 434). Otherwise known as "flaming behavior" this wanton disregard for other people is a curious expression of behavior as people would rarely ever say or do any of the things they exclaim in online forums, but one only needs to look at the comment section of many Yahoo News articles to see this sort of diatribe.

Lapidot-Lefler & Barak (2012) chose to measure effects of eye-contact interactions as well, specifying that eye-contact is different from visibility. They present research that reflects even when one is visible via technology such as a webcam, subjects do not take in the same level of information that they would from a face-to-face interaction Lapidot-Lefler & Barak (2012). To measure these effects, the researchers recruited 142 participants (71 men, 71 women) and separated them into dyads. Each dyad was given the task of debating a topic (a hypothetical life-saving drug dilemma: a specific type of drug is needed to save a loved one's life, however, only one research participant can get the drug creating competition between the two participants) through an online chat interface, whereby each dyad was assigned to one of three conditions based on the anonymity, invisibility, or eye-contact. Regardless of the condition, dyads would debate the topic and were instructed to come up with a mutually approved solution. Dyadic conversations were evaluated by four expert analysts and participants also filled out a flaming-behavior self-report. The results of this study intriguingly indicated that eye-contact was the strongest predictor of flaming behavior or threats. Lapidot-Lefler & Barak (2012) point out: "...although the eye-contact variable had no significant effects on all of the dependant measures, it caused more impact than either anonymity or invisibility in producing the toxic behaviors implied by online disinhibition" (p.440). This study's results give some credence to the

importance of limbic resonance and other elements of the human interaction in regulation of affect. The importance of this effect is especially salient in children, as we know that at young ages, the brain will ignore deficiencies in a brutally Darwinian manner.

In one of his many podcasts on IAD, Adrew Doan (2012b) examines relevant research and his own anecdotal evidence for IAD symptomology and possible implications of these behaviors. Doan (2012b) presents amblyopia (lazy eye) treatment in children as evidence for the brain's reorganization in response to deficiencies. Treatment for amblyopic children involves covering the dominant eye with a patch for a period of time, with time, the lazy eye will eventually catch up to the dominant eye. If this treatment is neglected, the brain will over-accommodate the dominant eye, and the lazy eye will become less and less functional. Based on this assertion, Doan (2012b) presents an interesting question:

If we are introducing technology too early to our children, what sensory, what behavior, what cognitive, what language development are we causing them to be deprived of, and therefore having their brains hardwired in a way where they are not able to communicate, and function properly as an adult? (27:47)

As technology addiction centers have begun cropping up in the world, one in the UK purports to have begun treatment with a four year-old girl for addiction to the family iPad (Ward, 2013). Speaking about parents allowing children to use mobile devices for play as well as for soothing, Dr. Graham (the center's founder) warns: "They can't cope and become addicted, reacting with tantrums and uncontrollable behaviour [sic] when they are taken away. Then as they grow older, the problem only gets worse" (Ward, 2013, paragraph 12). Doan (2012b) presents texting in considering the difference between a child that learns to text instead of learning to write with a pencil on paper, eventually learning cursive. There are physical and spatial sensory elements

that are lost in texting. If we translate this metaphor to parent-child attachment, one can only wonder what effects this is having on a child's brain.

Rosen's fifth rule presents an additional enigmatic component of technology's effects on attachment: technology is always available. Unless of course a computer is broken, one can always access Facebook; even in this case, a person can just find another computer to access their social network. This is different than the natural development of attachment in which the caregiver and child learn to accommodate each other's social rhythms: a computer does not seek out an upset child. Hilarie Cash and Kim McDaniel (2008) discuss this issue in their book *Video Games & Your Kids: How Parents Stay in Control*. They explain bonding as a quintessential psychosocial function that allows us to attach, trust, and consequently form relationships. Cash and McDaniel (2008) ask: "Are we raising a new generation of children who are bonding with artificial parents?" (p.100). As a result of his comprehensive review of psychobiological attunement research, Allan Schore (2012) discusses the importance of the parent-child attachment in the first year of life: "During the affective communications embedded in mutual gaze episodes, the psychobiologically attuned, sensitive caregiver appraises nonverbal expressions of the infant's arousal and then regulates these affective states, both positive and negative" (p.32). As a computer is incapable of making this biological transaction, one might understand why Cash and McDaniel (2008) call computer screens "cold caretakers", referring to the role many parents relegate to their iPads and televisions. The constant availability coupled with the lack of affect make for inadequate attachment figures; yet Cash and McDaniel (2008) anecdotally note how some parents report their children creating relationships with characters in computer games, yet express confusion as to whether or not they are real.

Results of a study by Holtz and Appel (2011) indicated that various levels of internet and technology use were predictive of problematic behaviors. Recruiting 205 individuals (100 male, 105 female) between the ages of 10 to 14 years, researchers surveyed participants based on internet and video game use and context, then had them fill out a self-report behavior assessment. Results indicated that certain types of games were related to certain types of behaviors. Internalizing problem (withdrawal and anxiety) behaviors were associated with playing fantasy games, while externalizing problem behaviors (such as delinquency and aggression) could be predicted by use of first-person shooter games, use of communicational technology, and amount of time spent gaming. Interestingly, researchers found teens that discuss internet use with their parents have a negative correlation with exhibiting problem behavior. This study underscores the importance of a parent-child relationship in lieu of a cold-caretaker.

Prevalence: Common Sense Media (2011) conducted a comprehensive survey of nearly 1,400 parents of children ages zero to eight, examining the pervasiveness of media and technology in American society. Given the theory and data reviewed prior to this, their results are staggering. Television still gets the most attention, with 65% of children ages eight and under watching TV at least once a day, with an average viewing time of 1:40 hours a day; video, computer, and handheld games receive an average of :25 hours per day. Television viewing begins in 66% of children under two years old, with the average age of first viewing at nine months. In their recommendations to reduce risk of technology dependence, Cash and McDaniel (2008) recommend zero screen time for children under two years, and one to two hours screen time for pre-school aged children. The Common Sense Media (2011) research posits that children under two spend twice as much time with screen technology then they do reading books. While most two-year olds haven't begun reading at this stage, this is where many children will

begin to lay important framework for reading and writing by having books read to them and pretending to read books by themselves ("Your two year old," n.d.).

Most children (98%) have at least one television set in their home, and 39% of children live in a household where the television is on all the time even when no one is watching it (Common Sense Media, 2011). These children averaged more television watching time (nearly double) and were more likely to be using multiple mediums at a time. Research by Alzahabi and Becker (2013) suggests that these children may be at higher risk for developing depression and anxiety. In addition, 42% of children eight and under reportedly had a television in their room.

Roughly one quarter (27%) of screen time in children eight and under is spent using digital media including computers, handheld games, video games, cell phones, video iPods, and or tablet style device (Common Sense Media, 2011). Mobile media is common in many households with 52% of children having access to a smart phone, video iPod, or tablet style device. A new consideration within this area of the research is the prevalence of apps; 29% of parents have reportedly downloaded an app for their child to use (Common Sense Media, 2011). Researchers found that on a typical day, 11% of children used a cell phone or mobile media device, for an average of 43 minutes (Common Sense Media, 2011); over the course of a year that comes out to over 260 hours.

What's more striking, is that apps don't just represent a new version of the cold-caretaker, but they are also indicative of what researchers are calling the "app gap" (Common Sense Media, 2011). This represents a socio-economic divide between higher and lower income families. Children of low-income parents have access to smart phones in 27% of cases, compared to 57% of children where their parents earn \$75,000 or more per year; 38% of lower-income parents weren't even familiar with what an app was (Common Sense Media, 2011). Common Sense

Media (2011) goes on to explain this disparity in access between educational technology and income brackets:

All of these disparities come together to contribute to a large gap in use of new mobile media devices: 22% of children from lower-income families have ever used a cell phone, iPod, iPad, or similar device for playing games, watching video or using apps compared to 55% of children from higher-income families. (p.21)

What will be interesting to learn in coming years will be is if IAD becomes a disorder relegated to individuals coming from higher income families based on increased accessibility to technology. A Waldorf school in California has chosen to swim against the pedagogical current, removing all technology from its classrooms (Richtel, 2011). Intriguingly enough, three-quarters of the 196 children that attend the elementary school come from high-tech families. While educators across the country determine what technology belongs in their classroom it's fascinating to find a movement by those that create some of the most prolific technologies, to actually remove technology from their children's lives. Regardless, Common Sense Media's (2011) finding that 98% of children have a television in their house suggests an inevitability of technological influence.

My research will examine the effects of technology on the parent-child relationship. The literature presented reflects technology's insertion into various components of interpersonal communication. As the basis for attachment-related behaviors, I assume that this cold-caregiver is impacting the parent-child relationship.

CHAPTER III

Methodology

Discussion

When discussing directions for future internet addiction (IAD) research, psychologists Joseph B. Walther and Larry D. Reid (DeAngelis, 2008) issued the two suggestions relative to this study: "More theory and research on why the internet compared with other outlets is so attractive to some people" (DeAngelis, 2008, paragraph 23), and "More study of which comes first, Internet 'addiction' or previous mental health or social problems" (DeAngelis, 2008, paragraph 24). Through a combination of personal experience and the support of current literature, this research will explore the first point raised by Reid and Walther (DeAngelis, 2008).

General design: This study is a qualitative study exploring the effects of technology on the parent-child relationship. At the time of writing this, I was not able to locate any singularly qualitative studies related to internet use disorders in general, let alone on this topic. The question proposed by this research is: "What are the effects of technology on the parent-child relationship?" This study sought out to recruit participants from various areas.

I recruited through two treatment centers (approval in Appendices B and C), Online-Gamers Anonymous (OLGA; approval in Appendix D), and an email list-serve comprised of clinicians and other people interested in IAD (approval in Appendix E). One of the treatment centers, reSTART, exclusively serves clients with technology addiction issues. The other treatment center, Insight Intensive, serves a broader range of clients, but still serves a significant

amount of clients dealing with technology addiction. Unfortunately, recruitment efforts only produced four interested people, and only two participants were able to complete the interview. Therefore, in order to supplement research data, four clinical staff (three from reSTART, one from Insight Intensive) were interviewed regarding their experiences working with clients that fit criteria for a technology addiction (HSR approval in appendix F). Therefore the research sample is comprised of two populations that were interviewed: treatment participants (TP) and clinician participants (CP).

This research utilized a deviant case sampling method of recruitment, a type of purposive sampling. For the purposes of this study, it was important for me to look at subjects who had developed problems related to internet and technology use. Had I used a more random sampling method I would be more likely to have participants who don't represent relevant testimony to the area I am seeking to explore. By focusing on participants who have had to enter treatment relative to the phenomenon in question, there is more certainty about whether participants currently have, or have had a problem controlling their use of technology. This particular sample could also lend some perspective to the chicken-egg situation that Reid and Walther (DeAngelis, 2008) recommended be investigated further in their second point.

Data collection instrument structure and design: Participants were interviewed using an interview guide (appendix J) that was developed by the researcher for the purpose of this study. The interview guide is comprised of 13 primary questions, along with 15 secondary questions, relative to participant's answers. The interview guide is intended to measure participants' attachment to their parents and their parents' views of technology. Questions from the guide are primarily open-ended, with some closed questions. While this isn't a firsthand account of the parents' view of technology, this information is still relevant to the phenomenon in

question as it is firsthand information about people who may or may not have developed an addiction due to a tenuous parental attachment.

In the interest of increasing reliability, the Adult Attachment Interview (AAI; Main, n.d.) was reviewed prior to the creation of this study's interview guide. The interview guide used in this research was a combination of original questions and questions adapted from the AAI (Main, n.d.). While the guide for this research does not carry the same level of validity or reliability as the AAI, the AAI's structure and supporting theory were relevant in lending convergent validity to this research. The interview guide was tested on a single subject whose information was not included in the research outcomes. The general structure of the test mimics the AAI in that it leads with broader questions relevant to technology, it then segues to some specifics around family and household perceptions of technology, and finishes with questions about the future.

Following testing of the guide, certain adjustments were made. The original guide included questions that were based on certain biased presumptions. These items were removed or reworded in order to remove bias as much as possible. The use of telephones removes some observer bias as the interviewer's facial cues and general affect were less influential to participants. Social desirability is a bias-type that is hard to control for in this type of research. Given that the TPs are in addiction recovery, part of their narrative may be distorted in self-reports to make themselves appear healthier. It is also important to consider that CPs may or may not have investment in IAD becoming a clinical disorder recognized by the American Psychological Association (2013), which may lend itself to bias in their responses.

Interview guide item number seven was appended with two specifiers, for before, and after high school. Given the advancement in maturation following puberty, it became clear that technology's purpose changed significantly during those times. In addition, the definition of

technology was expanded to include recorded music. This decision was made based on recorded music's evolution (from records, to tapes, to CDs, to mp3s, and on; as well as their associated players, i.e. walkmen, discmen, iPods, etc.) in association with other major social technologies. Hoover and Krishnamurti's (2010) research highlights how mp3 players distract many young people from their days, finding that 93% of those interviewed reporting turning up their mp3 players to drown out background noise.

Sample

As mentioned above, the sample is made up of two populations, participants who have completed treatment relative to their technology addiction (TP, n=2) and clinicians who work in programs that treat clients with technology addictions (CP, n=4).

Treatment participants: Four people responded to recruitment efforts, all from reSTART; however only two completed (n=2) the interview. One of the other two people did not qualify for the research as he did not meet all of the inclusion criteria, and the second person did not follow up after initial phone calls. This program treats individuals that have issues managing problematic internet, gaming, and/or technology use. Participants enter the program following a history of problematic technology use, which typically experience symptoms similar to a substance abuse diagnosis:

...“preoccupation” with the internet or internet gaming, withdrawal symptoms when the substance (internet) is no longer available, tolerance (the need to spend more and more time on the internet to achieve the same “high”), loss of other interests, unsuccessful attempts to quit, and use of the internet to improve or escape dysphoric mood (Walton, 2013, paragraph 2).

Given the nature of the research, this program seemed the ideal place from which to draw a sample.

Both members of the TP group identify as white males in their early twenties (23 and 21 years old). Both participants graduated from reSTART at the time of the interview, participant #2 (TP2) was nine months removed from the program, participant #3 (TP3) was two months removed. Both participants have siblings, and are not the oldest sibling. Both participants noted using television for two hours daily, and a PC or console device for gaming, for more than five hours a day (TP2 = 5+, TP3 = 6-8). Neither participant endorsed using a cell phone much during their day (TP2 = <30 minutes, TP3 = 0 minutes).

Demographic collection (Appendix K) included the Adult Style Inventory (ASI). The ASI is a scale that measures current attachment style by self-report. TP2 Scored highest on the secure attachment measure, followed by dismissing, then fearful style. TP3 scored highest on the dismissive attachment measure, followed closely by the other three measures (secure, preoccupied, and fearful). TP2 graduated from reSTART nine months prior to the interview, versus TP3's two months. This may partially explain the variance in attachment styles as TP3. All participants in the study come from a two-parent household. Sexual make-up of the parent dyad was not relevant to this research, the number of parents was. Research by Patterson (2006) demonstrates the sexual make-up of one's caregivers does not necessarily affect ability to form secure attachments, but rather the quality of family relationships. As recently as 2010, the American Psychological Association (APA) has publicly re-asserted its support for same-sex marriage equality. APA president Carol D. Goodheart (as cited by Willenz, 2010) stated the issuance of support, stating:

...we are using the opportunity presented by our annual convention to present the growing body of science that is the foundation for our position, and that has influenced many of the legislators, judges and other public officials who are working to achieve this goal. (paragraph 2)

Feeney and Monin (2008) posit:

A large number of studies have investigated the impact of divorce on children's attachment later in life. With a few exceptions, the consensus is that adolescents and young adults from divorced families are more likely to be insecurely attached than those from intact families..." (p.944).

Given this information, participants growing up in single-parent or step-family households were excluded from this research. In addition to growing up with one parent, adopted or foster children were excluded from this research as well. Research from two studies (Pace & Zavattini, 2010; Barone & Lionetti, 2011) concluded that adoption can provide a foundation for an individual to create a secure attachment (or an "earned secure" attachment); however, factors such as parent's attachment style, and age at which one is adopted may influence these results. This study is not prepared to explore such factors. This research controlled for these variables in the interest of increasing the validity of the study's findings so that any attachment ruptures in participant lives aren't likely to have stemmed from events such as these.

The AAI (Main, n.d.) was reviewed and mimicked in an attempt to achieve convergent validity as best possible. The instrument used in this research is unique in that it looks at the individual's attachment to their parents, as well as assessing the parent's attachment to or dependence on technology in their environment. This is an important concept to this research: if

children TP were observing and likely emulating parents that were dependant on technology, it would make sense why they would form an attachment to this cold-caregiver later in life.

Clinical Participants: Data collected for CPs included age, race, gender, position title at their treatment center, length of time having worked at their treatment center, and licensure information. All clinicians identified as Caucasian/White. Age ranged from 40 to 60 years. Length of time working at their treatment center varied from 15 month to 54 months. Three of the four clinicians are licensed in the state where they practice, amount of time being licensed ranged from 15 months to 19 years.

Data Collection

Data collection procedure was approved by a Human Subjects Review (HSR) committee (Appendix A).

Treatment group: Research recruitment letters (Appendix G) were sent to three sources (reSTART, Insight Intensive, and an email list serve) and posted on the OLGA web forum. Interested participants were asked to call a number or send an email expressing their interest in the study and leaving a preferred method for a return contact. Interested participants got a call or an email back for the purposes of informing them of the voluntary nature of the research and that their participation won't affect their standing with their treatment center, scheduling an interview time, and requesting a physical address so that their paperwork including their letter of consent (appendix H), demographic collection (appendix K), and referrals (appendix M) can be mailed to them. The HSR committee approved paperwork was mailed to interested participants along with postage for returning their completed paperwork. Once paperwork was received, interviews could be conducted.

Interviews were conducted by phone over *Skype*. A phone number was created for the purpose of research interviews. The program *Amolto Call Recorder* was used to record the *Skype* conversations. *Amolto* is designed specifically for recording *Skype* conversations. After recording, *Amolto* converts conversations into an mp3 file. While interviewing the CP group, participants began to report a problem with the recording technology, reporting they were having trouble hearing me at times. Best efforts were made to accommodate so that participants understood each question. Upon completion, interviews were transcribed.

The demographic data collected includes age, gender, birth order, technology addiction type, and amount of time since completing reSTART. Age and gender represent basic but important information in this literature. Several of the studies relevant to IAD literature utilize samples primarily made up of males, in young adulthood (18 to 25 years old; Dong et al., 2011; Han et al., 2011; Hou et al., 2012; Kim et al., 2011; Ko et al., 2009; Zhou et al., 2011). Since it was anticipated that this research will draw a similar population, affirming this demographic is important to the generalizability of these findings. Birth order was deemed important after review of some findings by Louis Cozolino. Cozolino (2002) found that, when a mother's attachment to her infants is measured, the attachment scores will likely vary across infants. Additionally, the architecture of the mother's brain is fundamentally altered following the birth of a child (Cozolino, 2006). Amount of time since completing reSTART appeared important at the onset of research as participants who have completed the program may have adopted a different perspective from participants that are still in the program.

Clinical group: Following the resulting recruitment for TPs, clinicians who work with clients that entered treatment due to their technology use, were solicited to supplement research data. A recruitment email was sent to the clinical staff at reSTART, and two clinicians at Insight

Intensive. These clinicians (n=4) were emailed their letter of consent (appendix I), demographic collection (appendix L), and professional references (appendix M) along with return instructions. Upon receipt of their letter of consent and demographic data, interviews were scheduled by email. Interviews were conducted in the same manner as the TPs, however, interviews tended to last longer, between 22 and 45 minutes.

Data analysis

Transcriptions were analyzed by myself and color-coded using theme and content analysis. Themes in the transcriptions were identified and put into a chart. They were then color coded for organization, and then grouped together into five separate categories: (a) child-technology attachment, (b) parent-child attachment, (c) parent-technology attachment, (d) family bonding, and (e) insight and altruism. Following the coding of TP data, CP data was coded using identical methods. CP data was compared to TP data in the best effort to triangulate information pertinent to the study. Most of the data used for the study was data from TPs that aligned with or was contrary to three or more clinicians, unless otherwise noted. In some cases, data from one or two clinicians was noted as it made for unique data that the author felt was relevant to the audience. Data was then re-evaluated and tied to relevant literature.

The Interview guide intended to explore several attachment dynamics: Parent-child relationships, parent-technology relationships, child-technology relationships, and familial bonding. When examining any attachment relationship, a child's connection with their caregiver will be crucial to understanding the formation of that individual's internal working models (IWMs). Marvin and Britner (2008) purport the importance of the first year of life in the creation of IWMs. Common Sense Media's (2011) findings suggests there is a high level of child-technology interaction in children as young as eight years old. Considering the link

between the genesis of various IWMs, and the increasing presence of technology in the lives of children, looking at both (parent-technology and child-technology) perspectives is important for this research. Since the child learns much about what is important by observing their parents, their parent's technology use is critical to understanding the individual's responses.

Unfortunately, the first year of life isn't an area of memory one can typically recall; therefore, there may be a large portion of data that contributed to one's IWMs that is not accessible to the individuals being interviewed. Familial bonding is important to the research as a recent study found that parental bonding was one of the best predictors of IAD in teenage participants (Siomos et al., 2012). Data collected from the research produced some interesting findings.

CHAPTER IV

Findings

Despite the small sample size, this research revealed some fascinating results. While these results present interesting perspectives, they are by no means generalizable due to the small sample size. However, these results may be helpful in future IAD research.

General TP Findings

Like other addictions, participants from this research demonstrate how the roads to their maladaptive use can look very different despite the shared problem. One of the participants developed his addiction after leaving for college. He described a structured childhood, pleasant familial interactions, and moderate interactions with technology overall. The second participant described his childhood as being more technology seeking. In addition, he describes his father as a gaming addict, at one point having to choose between his marriage or his games. While these two participants' path to technology addiction were different, there were still some themes that emerged from their interviews.

In both cases, there were reports of social isolation, as well as some shared familial themes. Social isolation was a common part of both narratives. Participants reported having few friends, lying often, and avoiding social interactions.

In terms of familial themes, both participants interestingly enough reported that they grew up closer with their father than their mother. While both remarked that they were closer with their father, one participant remarked that an outsider may see it differently: "...if anyone

would look from the outside they would say my mom was closest to me." Elaborating, the participant remarked: "...my mom sort of hovered over the top of me and tried to make sure I was doing everything right."

Complimentary to the idea of being close to their fathers, both participants reported feeling like their mothers were pre-occupied with their cell phones. Both participants had the perception that their fathers primarily used technology for business. When asked about how their families handled emotions, both participants reflected feeling like emotions were to be withheld, one participants remarking much more directly than the other, answering: "Suppressed and lied about."

When asked as if they ever felt like they had to compete with their parents' technology for attention, both participants made remarks about their mothers' cell phone use. In both cases, participant's mothers reportedly used the cell phone often for social purposes such as email, scheduling, or shopping.

When discussing internet use, both participants remarked that they began using the internet around the same age: close to 12 years old. In addition, they both began using it for school work initially, however both also indicated they eventually began using it for games. Neither participant had much technology in their room, and in both cases technology was sometimes restricted based on their behavior, so after classes at school sounded like another convenient avenue for them to indulge. Participants also made some remarks individually that were notable as well.

Participant # 2. One of the most notable points of participant # 2's (TP2) interview were his remarks about his parents' technology use as addiction. TP2 reported at a very young age, being aware of his father's attraction to video games and the conflict that these games created in

his parents' relationship. Regardless of the connection between his gaming behavior and his father's, TP2 believed it was their faith and spirituality that engendered intimacy between he and his father. Following his description of his father's addiction, TP2 is asked to choose five words to describe his mother's relationship with technology; while doing so he remarks: "I might just be basically describing an addiction here." Technology appeared to be an integral part of TP2 and his family's life.

TP2 reflected on how gaming was used as an activity to be removed for misbehaving as well as a reward for refraining from problem behaviors. Limits were established around gaming regarding hours per day, and days of the week in which it would be allowed as a result of bad behavior. TP2 also reflected how his parents used it specifically for bed-wetting problems when he was younger: "I was a bed-wetter until my late years and at one point, if I didn't wet the bed, then I could have free time playing games." TP2 connected this to his problem-gaming later in life, where he would often play games for such a long time that he would forget to take bathroom breaks. Despite his excessive gaming habits, TP2 still saw himself as growing up largely sheltered from technology, reporting he didn't really start to use technology until he was eight years old. Despite feeling like he was sheltered from technology, TP2 described a clear attraction to finding ways to use technology often. TP2 reported a period in his life where he would spend the days rehearsing where to walk in his house to create the least amount of noise so that he could sneak down to play computer games after his parents fell asleep: "...and it would be really difficult to sneak downstairs. I had to learn like, all the spots in the floorboards."

In closing, participants were asked questions that encouraged them to reflect on their experience and give advice based on what they feel like they've learned. TP2 reported feeling like it's a popular misconception that the internet connects people, but that there are better ways

to connect. TP2 reflected that he believes there are better ways to live, rather than through technology.

Participant # 3. Participant number 3 (TP3) reported less of an attraction to technology during his younger years than did TP2. TP3's family seemed less preoccupied with technology-use outside of business purposes. He never believed it to have been the source of any relational problems outside of occasionally one parent needing to tell the other to put their phone away at the dinner table. TP3 reported an attraction to personal computers because he used to maintain and repair them, using them as a tool for learning; his console use, specifically Xbox, was largely about social connection.

Like TP2, TP3 reported feeling closer to his father than his mother. TP3 believed this connection to have been fostered through their enjoyment of golf and other sports, as well as discussing business. Although he felt closer to his father, TP3 reported that if he had to go to one of his parents for advice, the first one he would go to was his mother.

In closing, TP3 reported feeling like the gaming rating system is often taken too liberally: "...I wish parents understood that the reason why games have an 'M' rating on them is because the game is for mature kids." TP3 goes on to purport: "I wish that parents didn't have to use their consoles as a pacifier for their kid." In addition to giving his treatment center a shining endorsement, TP3 reported that the best thing he felt someone with technology addiction can do is ask for help: "... technology is literally everywhere. It's hard to avoid, it's hard to get around...I would probably say, asking for help is the best thing you can do."

General CP Findings

The CPs (CP6, CP7, CP8, & CP9) that were interviewed for this study supplemented the data provided by the TPs to create a more robust collection of data. CPs identified technology as

often being a detrimental influence on their clients' lives growing up, reporting that it was often a way to avoid social ineptness that commonly resulted from face to face interactions. CP's added that it was often the source of intrafamilial conflict. Three of the CP's noted a common process that they often see develop as a result of technology's influence, whereby a child grows up playing technology and as they get older parents begin to notice it as problematic. In response, parents try to limit technology. The child in this case is often more technologically savvy than the parent, so not only do they often resent the parent for setting the rules, but they are often skilled at getting around the rules. One CP referred to this as a "vicious-cycle." CP's note that in early childhood, limits aren't as frequent as it appears to be a way to keep their child (and sometimes their friends as well) occupied, but that this is also when the child typically develops a fascination with technology. As peers pull away, technology-use (and often gaming) becomes a refuge. One clinician noted that sometimes this is to avoid social anxieties such as bullying: "A very high percentage of kids were bullied, and so I think a lot of the time the parents were okay with their amount of gaming..." As they get older, it is common for the child to withdraw from social events and isolate in their technology use. CP's noted that parents don't often recognize what they are modeling implicitly with their own technology use.

Many of the families that CPs work with have at least one parent with a high-profile job. These jobs often demand a high degree of time, travel, and/or communication (most often through phones and/or emails). CPs noted that sometimes technology use is encouraged at a young age, the child is relished for their technological mastery. CP7 noted:

...parents sometimes just admire their kids. And kids are much smarter than the parents are about the technology, and rely on the kids, to help them out with technology. And the kid is the authority, and the parents admire that.

CPs noted that fathers in the families that they work with are often the ones that are working, CPs believed their clients would view their father's technology use as business-oriented. Mothers in the families with whom they worked were typically described as being less tech-savvy than other family members. Two of the CPs reported mothers in these families are often helicopter-parents. Despite this perception, CPs believed that their clients would be more likely to be closer to their mother than their father, usually for the reason that the mothers in these families are often the ones raising the child. CPs believed that this closeness wasn't necessarily engendered by any particular interests, but rather the very act of parenting is what brought about their closeness. CP9 noted this would depend on the mother falling into one of two typical categories:

One, the mom has been a little more sensitive to his struggles because she'd be around more and dad works. And the other situation, mom's around more and is more a disciplinarian, and interacts, and sees more of the behavior with technology: the isolating and so forth.

Outside of their parents, extended family members were often noted by CPs as people clients typically mention as being influential.

Some CPs noted that teachers and coaches sometimes get mentioned as well. As noted above, CPs reported believing that their clients' parents didn't set too many rules often early in life, it seemed more like in their pre-adolescent and teen years that rules started coming into play. CPs reported a wide spectrum of rule-setting from very few rules, to a stricter level of rules; usually gaming and technology use was tied to certain behavior such as completion of homework or getting out of bed on time. When seeking out advice, CP's believed that clients would often utilize technology, as for many clients that is their only support network. Several CPs indicated

that they may ask their parents or friends when seeking advice, but often parents and child weren't so close, or the child may have few (if any) friends to turn to. CPs described families of their clients as being invested in helping their child resolve negative emotions. CP8 noted how social perception of the family is important to many of them; because of this, the family may stifle emotions and lead to a higher frequency of treatment. Several of the CPs reported their clients are often seen in other treatment scenarios prior to arriving at inpatient treatment.

As private treatment is expensive, families that CPs work with are often affluent. CPs reported that many clients are well equipped with technology in their room. CP reported many clients having things such as phones, televisions, and gaming systems in their bedrooms, in addition to portable technologies such as Gameboys. CPs believed clients probably began using technology around ages five to nine years old, as low as two years old in some cases. CPs reported internet use probably came later, two of them reported this probably started in middle-school. Evolution of technology use was perceived to have started as simple surfing and some gaming prior to high school, then during high school moving to a more consuming use of technology: gaming, pornography, online television and movies, as well as blogging or reading various forums that they are interested in. CPs reported that television didn't seem to be too much of a focus by their clients, but rather was often more of a "fallback", where it was used when gaming technology was taken away by their parents.

In closing, CPs voiced concern for the impact technology has on young children, especially in the current generation. CPs cautioned the importance of proper boundaries in technology use in young children. In terms of what advice they would offer to those struggling with technology addiction, CPs stressed both the importance of removal of technology for a period of time in addition to a therapeutic relationship. An important note CP6 brought up was

that the clinician one seeks out should be familiar with IAD, as they often see clients who received therapy focusing on other diagnoses: "It's just we see this entrenchment in the wrong treatment, and the wrong diagnoses...it's really not just about getting help, it's really about getting the right kind of help." The findings from this research and the current literature on IAD make for some interesting implications.

CHAPTER V

Discussion

The findings of this research revealed several different themes. Due to the qualitative design and the unfortunately small sample size of this research, it is again worth noting that this information is by no means generalizable, but rather may provide interesting considerations for future research on IAD and attachment. The interview guide for this study was designed to measure five different concepts relevant to IAD.

Child-Technology Attachment

TPs reportedly experienced social isolation throughout their lives. They reported (and CPs confirmed) that they often had few friends and avoided in-person social interactions. This is an aspect of IAD that is common to the individual narrative (Rosen, 2012; Whang et al., 2003). Whang et al. (2003) found that the IAD group in their research experience interpersonal difficulties and stress in reality. TPs remembered problematic technology use beginning in their middle school years, another point corroborated by two CPs. Gentile's (2009) research on pathological video-game use supports this finding, reporting internet use remained stable between the ages of eight and 13 in their research. Contradictory to TP2 and most CPs reports, Gentile (2009) did not see a dramatic increase in game play in high school; rather, he saw frequency of game sessions decrease, but total time of use also decreased some after 13. According to Kerns (2008) this period is when TPs would be adjusting to a more peer-focused attachment network, where parental availability (versus proximity) becomes the child's focus, but

frequency and intensity of parent-child interactions are diminishing. TPs reported it was common for them to use technology during and after school (at the school); this highlights an example of how technology may have provided a refuge against exploring in-person social interactions, resulting in further social isolation. Whang et al. (2003) corroborate this finding, positing: "As a consequence of such dysfunctional social behaviors, lonely people would feel lonelier, because their need to belong is insufficiently met" (p.149). Research suggests that the brain (in participants meeting IAD criteria) experiences a surge of dopamine in the striatum in response to video game play (Han et al., 2011), leading to dysfunctional reward system in the striatum (Hou et al., 2012; Kim et al. 2011,), an area of the brain thought to interpret love and affection (Han et al., 2012). Hou et al. (2012) speculate that as the dopaminergic pathway is repeatedly stimulated individuals with IAD have been known to decrease the functionality of the dopamine terminals, suggesting the development of a tolerance to the stimulus. This would support the increasing levels of internet use described by CPs, and TP2, so that the user can get high. Kerns (2008) also points out the emergence of research positing the effects of a secure attachment on peer competence during these years, specifically that secure-attachment style and peer competence are positively correlated. In the case of these two young men, technological refuge would only fuel this correlation.

The child-technology relationship seemed to evolve over the course of the TP's lives. In early years, technology seems like it was viewed as something that could help the child, in that it kept them safe and occupied, requiring less parental supervision than other types of play. In TP2's case, technology use was coupled with his bed-wetting behavior, he went on to explain that when he was really into his video game addiction he would neglect to take bathroom breaks. Han et al. (2012) found compromised functioning of the anterior cingulate cortex in subjects

with IAD. They suggest this could diminish one's awareness and inhibition of inappropriate behaviors, such as TP2's bathroom hygiene. As embarrassing as this was for TP2, it is also reminiscent of Eagle's (1995) point: "As Sroufe and Fleeson (1986) note, an important motivational factor in the perpetuation of attachment patterns is the desire to reproduce a familiar relationship pattern, one known and understood" (p 142); however unpleasant, TP2 may have been recreating a situation which was familiar to him. As the two TPs got older, their relationship with technology seemed to become more obsessive. In response to this, their parents began limiting technology according to their expectations of their child. Interestingly enough, research by van Eijnden (2010) found that rules and limits around technology were positively correlated with compulsory internet use, suggesting they may promote development of compulsory internet use. As one CP put it, these families entered into a "vicious-cycle" whereby the parent would set rules, the child would get around them, the parents would get upset, but the child would want to use technology more and would begin finding ways to use technology without their parents knowing. This could be at school, at a friend's house, or like TP2 mentioned, up late at night; regardless of which outlet, this behavior often led to parent resenting their children's behavior. A two-year longitudinal study (Gentile et al., 2011) supported the possibility of the vicious cycle: "Once players became pathological gamers, they began to have poorer grades and poorer relationships with their parents..." (p. 325). Research has found the dorsolateral prefrontal cortex (DLPFC) was often activated in response to video game-related cues (Han et al. 2011; Ko et al., 2009). This finding may shed some light on the genesis of the vicious cycle, as this part of the brain is responsible for linking past experiences with present sensory experiences (Han et al., 2011). Additionally, the DLPFC manages working memory, therefore Ko et al. (2009) suggest this activation seen in IAD subjects represents craving. The

orbitofrontal cortex was also found to be activated in (Dong et al., 2011; Ko et al. 2009) research, the part of the brain responsible for goal-directed behavior. The sum of this research would suggest that as an individual begins to crave technology use, another part of the brain is simultaneously planning how to get connected. TP2 reported rehearsing a route he would need to walk in his house so as to avoid waking his parents late in the evening; they would find him playing at two and three in the morning sometimes. Technology management came to monopolize the parent-child interaction.

Parent-Child Attachment

One term thrown out by both a TP and a couple CPs was "helicopter-parent". At the time of writing this, much of the research on helicopter-parenting was done in relation to young adults, 18 and older (Fingerman et al., 2012; Padilla-Walker & Nelson, 2012; Schiffrin et al., 2013), however this researcher did not find any research relevant to children under 18. A helicopter parent (a term sensationalized by the media) regards a parent that is consumed with the livelihood of their child. Goldstein and Thau (2011) underscore the perception of such parenting practices: "... their 'helpless' children must be protected against experiences of failure and unfairness in life" (p.70). An interesting part of the helicopter-parent narrative is the commentary that they have to "protect their investment" (Montgomery, 2010, paragraph 2). This statement conjures up thoughts of a business, arguably antithetical to familial bonding. This is an important concept to child-parent attachment for a couple of reasons. First, this type of parenting stifles the youth's ability to explore and gain autonomy (Allen, 2008) during their teenage years. Allen (2008) reflects: "When autonomy-undermining, enmeshed behavior between mothers and their adolescents was observed at age 16, this predicted relative *decreases* in levels of security from age 16 to age 18" (p.426). Secondly, this suggests the parents' inability

to tolerate their child's failure (i.e. a "failed investment"). When considering the likelihood of a successful goal-corrected partnership (GCP), this presents a problem as Allen (2008) reports one of the key ingredients of the GCP is: "...a willingness among both parties to allow the adolescent to seek autonomy while maintaining the parent-teen relationship" (p.424). With this protecting-my-investment mentality the GCP appears to be undermined as the parent is dictating the teen's path, as opposed to giving the child the opportunity to make decisions and face his consequences. Liu & Kuo (2007) support this finding in the conclusion of their research purporting:

Anxiety picked up from caregivers or parents in the early stages of development, however, can be overcome and social skills can be improved if people develop good relationships during adolescence.⁶ Therefore, educators and parents should focus on early prevention by ensuring healthy interpersonal and parent-child relationships during childhood and on programs that help to improve social skills for the adolescent. (p.803)

CP9 noted that he's observed mothers of clients using technology for keeping track of them. Findings from research on internet addiction and parental bonding done by Siomos et al. (2012) supported avoiding parenting approaches of this nature:

We can expect parents with a high degree of affection and care for their children, who also understand their needs for individuality and self-expression, to be more involved in their supervision to a degree that does not curtail autonomy but instead respects personal boundaries. (p. 218)

In their exploration of family factors and varying degrees of both substance abuse and IAD, Yen et al. (2007) add:

...we suggest that family-based prevention should include skills training for parents to improve communication skills in helping adolescents to develop social skills, helping family members reduce maladaptive family function, fostering skills for health family interactions, and effective family monitoring and discipline focusing on Internet [sic] addiction and substance use. (p.327)

Whereas twenty years ago, it was common for a parent to have their child call them to check in occasionally, the advent of cell phones in recent and current generations has made children more accessible to their parents than ever. These devices make the phase of relinquishing parental control (an important transition during early attachment) less tolerable to parents who now choose how much autonomy they want to allow, whereas in the past there wasn't such technological convenience to connect with one's child.

Both TPs endorsed a willingness to seek out their parents if they needed advice, either their parents or a friend. CPs postulated that for a lot of their clients, their parents may be their only support network outside of their online social network and a handful of real-life friends. As discussed earlier, this social isolation, often accompanied by feelings of social anxiety, is a common part of IAD literature (Cash & McDaniel, 2008; Liu & Kuo, 2007; Rosen, 2012; Tsai et al, 2009). Rather than setting out to build a social network, and managing the emotions that come with exploration, acceptance, and rejection, TPs would find solace in their online community. Supporting this notion, TP2 noted that in times of needing advice he would sometimes turn to technology to distract, ignoring his feelings. Whang et al. (2003) found similar results, with IAD participants being the most common to report using the internet in that "they hoped to avoid reality" (p.149).

Contrary to CP's beliefs, both TPs reported feeling closer to their father growing up. One CP noted this would likely be the case with many of their clients, as they often yearn for their father's attention. Three CPs reported believing that clients would likely be closer to their mothers on account of fathers typically being busier with work. The nurturing maternal interactions, especially during early years, was mainly what CPs believed would engender closeness between mother and child. Contradictory to CP belief, TPs believed they bonded with their fathers over other interests, such as religion, sports, or business. As children are keen purveyors of important things in their parents' lives, it is worth noting that business is something that emerged as an interest that engendered father-son bonding in CP3's case. This is the only research to this researcher's knowledge to examine parental preferences amongst subjects with IAD.

Parent-Technology Attachment

CPs noted that parent technology use wasn't something they often heard about. A rare case according to CPs, TP2's father's purported gaming addiction makes up an interesting facet of his story. TP2's father reportedly had to choose between gaming and his marriage when TP2 was a very young age. Flisher (2010) suggests subjects with IAD commonly have marital problems that may end in dissolution of a marriage. In addition, research done by Dong et al. (2011) found that subjects with IAD had a decreased sensitivity to monetary loss, suggesting: "This may provide information that why Internet [sic] addicts indulged into the internet and failed worrying about their behavioral consequences, which eventually caused psychological, social, and work difficulties in their life" (p.1528). Schore (2012) describes the dual processes of "interactive regulation" and "autoregulation" (the ability to be soothed by others, and the ability

to soothe oneself, respectively) to be a result of parent-child interactions during the child's infancy:

In moments of interactive repair the "good enough" caregiver who mis-attuned can regulate the infant's negative state by accurately re-attuning in a timely manner. The regulatory process of affect synchrony, which creates states of positive arousal and interactive repair that modulate states of negative arousal, are the fundamental building blocks of attachment and its associated emotions, and resilience in the face of stress and novelty is an ultimate indicator of attachment security (Schoore, 2005b). (pp. 75-76)

Depending on when this event with TP2's father took place, there are a multitude of attachment implications. We can assume his father was gaming into some portion of TP2's infancy if the event happened after birth, crucial years relative to parental influence. Lewis et al. (2000) stress the importance of limbic resonance during these years; coupled with Schoore's (2012) assertion, one can assume this parental disconnect may impact neural development in a developing infant.

Both TPs reported feeling like their mothers were often pre-occupied with their cell phones, TP2 noted this was common specifically when he and his mother were in the car. Based on TP2's perception of his mother, what could be a moment for connection between mother and son, appeared to turn into an isolative moment. TPs both reported feeling like their fathers would use technology primarily for business. This was also the perspective of the CPs, as they reported the father as often being consumed by work, but not necessarily using technology like their children. Goldstein and Thau (2011) posit that this consuming life-style may impede attachment security:

Caregivers' ability to tolerate and inhibit their own arousal system creates the building blocks that will eventually be the foundation and scaffolding of the developing child. While some caregivers, through reflection and self-awareness, are aware of this awesome responsibility, others function in a highly self-focused state, which in effect acts as a barrier in terms of forming a real attachment to their children. (p.67).

One CP noted "...they don't value enough, the connection to their kids to really seek out what's happening and try to correct it." Caregiver connection to work presents an interesting piece of this puzzle. While TP2's story suggests that it's possible IAD can be a learned behavior (from his father), TP3's story (in addition to the general consensus of the CPs) suggests a parent's relationship with their work can interrupt the attachment process as well. The jobs of these parents are described as "high-profile" suggesting they are lucrative, consuming, and demanding, much like technology use. According to CPs, this high-profile lifestyle seems to be passed on to the children of these parents, as CP8 put it:

...these kids don't know how to sit under a tree for an hour and be bored...instant gratification is becoming like, a big problem. Electronics are teaching kids what life should be. You should have a goal, accomplish it, and move on to the next thing right away."

Rosen (2012) suggests the importance of interacting with a natural environment in what is referred to as "attention restoration theory":

...when someone interacts with a natural environment their attention is captured in what is referred to as "bottom up" process, meaning that it is driven by calming

external stimuli seen in nature, allowing parts of the brain that are overworked to recover. (pp. 204-205).

When combined with Schore's assertion that human brain's organize other human brains, these statements suggest that this high-profile lifestyle may be passed on. As CP7 suggested, parents are often unaware of the behavior they're modeling. Van Eijnden et al. (2010) found quality of communication about internet use to be a better predictor of compulsory internet use than parenting style. Combining that information with the findings of this study suggests the importance of clear parent-child communication around technology use.

Family Bonding

TPs both reported that technology did not enhance their relationship with their parents, that they would often avoid their parents in favor of their technology use. CPs supported this perspective, claiming that technology interrupted clients' relationship with their parents in most, if not all, of the families that they work with. Reflected in the IAD literature, the impact of parental bonding was examined by Siomos et al. (2012) who found that parental care was negatively correlated with IAD. The parental avoidance reported by TPs and CPs could be the beginning of the aforementioned vicious-cycle, where the child's technological-preoccupation leads to limit setting. Although at a younger age, there was reportedly less technology restrictions.

CPs report that in many clients lives (and was also the case in TP3's life), technology use is encouraged at a young age, and technological mastery is even heralded in many families. CP7 noted:

...parents sometimes just admire their kids. And kids are much smarter than the parents are about the technology, and rely on the kids, to help them out with technology. And the kid is the authority, and the parents admire that.

No longitudinal research examining specific differences in technology restrictions across childhood was located at the time of conducting this research. There aren't many tools in human history that children can teach their parents how to use as handedly, as many important technologies today (including various facets of using the internet and smart phones). Most modern conveniences and/or life skills such as driving, using a map, cooking, social etiquette, and so forth; are skills that are often passed on from parent to child. With children integrating technology into their lives at earlier stages, there appears to be an apparent role-reversal.

Modern child and teen generations are becoming increasingly familiar with new technology far before their parents earning them the moniker "Millennials" (Pew Research Center, 2010).

The grade school to middle school years are thought to be important for parents and child to move from a relationship based on parental control, to a relationship based on mutual co-regulation and parental availability (Kerns, 2008). While technology has certainly increased ease of parental availability, there are many technologies that children master far before their less tech-savvy parents. This perceived self-reliance by the Millennials may translate to the increased perception of narcissism by the rest of society (Rosen, 2012; Stein, 2013).

Insight & Altruism

Having their unique experience with technology, both TPs had interesting insights that they wished more people understood. TP2 spoke about the paradoxical effect of technology: that it supposedly connects people, but in his experience there are better ways to connect in real life. Research by Farber et al. (2012) found that young people tend not to be too intimate in their

online friendships, and that their online social network interactions were described as superficial.

Farber et al. (2012) posit:

...adolescents and young adults may satisfy their need for frequent boosts to their self-image by sharing status updates on their accomplishments, posting revealing pictures of their bodies, and otherwise expending a great deal of mental energy trying to convince themselves and others that "all is well." Although they may be temporarily comforted by receiving "likes" for a skin-deep or false persona, young people-including our patients-may ultimately feel quite uneasy and even disturbed by the incipient awareness that they are being rewarded with "likes" for keeping their true selves, including their pain, hidden and unheard. (pp.1228-1229).

Farber et al.'s statement is eerily similar to an alcoholic who is dying on the inside, but is constantly told by friends that he's the life of the party when he drinks. CPs supported the statement TP2 made regarding the paradoxical effects of the internet, referencing the preferred way to approach a technology addiction: disconnect from technology, reconnect with people and nature (the removal of technology altogether, at least as much as possible). While most CPs recommended seeking out a therapeutic relationship, CP7 brought up that one can even seek support from a 12-step community (such as Alcoholics Anonymous). CP7 stressed the importance of reaching out: "Even if they're going to AA meetings, they can still get a lot of support by saying: 'I'm an addict, and I need support.'"

TP3 underlined the importance of the rating system that video games have adopted, and also inferred his sympathy for the children of parents who use technology as a baby-sitter. This point was also echoed by CPs. Common Sense Media (2011) found that of families surveyed in

their study, two thirds of children eight and under are watching television at least once a day for roughly 1:40 (hours); more interestingly, nearly half of toddlers zero through one spend an average of nearly 2:00 a day watching television. Although they also found that when they asked parents whether they ever used technology as a baby-sitter, the numbers looked different in that 15% of parents surveyed replied "often" and 42% replied that they "sometimes" use technology as a babysitter. A report released by the Nielson group revealed: "...seven out of every 10 children in tablet-owning households used a tablet computer" (Nielson, 2012, paragraph 1). They elaborate on other uses:

Seventy-seven percent of those surveyed said children play downloaded games on their tablets and 57 percent said children used tablets to access educational apps.

The portable gadget also keeps kids quiet while families are on-the-go: 55 percent and 41 percent of parents report that their children used tablets for entertainment while traveling or in restaurants, respectively. (Nielson, 2012, paragraph 2).

One clinician raised the point that the many of the clients they are seeing currently, didn't grow up with the pervasive access to technology that we are seeing in the coming generation. Studies that suggest the detrimental effects on an infant that utilizes technology before the age of two (Christakis, 2008), as well as the alacrity by which human brains can rewire to accommodate new technology (Small et al., 2009), makes this an important consideration for future generations.

Limitations of This Research

The small sample size of this research is likely the most impactful limitation on this research. In retrospect, relaxing the inclusion criteria may be beneficial to qualitative studies on this topic in the future, specifically regarding the make-up of participant's parents. Excluding

adopted participants, participants from single-parent, divorced, or re-married families may have significantly reduced the sampling pool. In addition, social anxiety is a common symptom observed in people with IAD. Sharing the intimate details of one's story for research purposes may seem too intimidating for other eligible participants. Furthermore, excluding people who are not in treatment may have limited the sampling pool significantly. For such a novel phenomenon, future researchers may benefit from finding participants that currently fit (or have fit in the past) the criteria for IAD, but not make treatment a requirement as well. And finally, this study may be a bit ahead of its time, in the sense that present-day children are the ones being exposed to advanced technologies such as tablets and smart phones. The differences in terms of available technologies during the eighth year of TP2 and TP3s life are markedly different than the technologies that many eight year-olds enjoy today. If the findings from IAD have the effects that the research suggests, then we would expect to see this population grow in the coming years, in which case there may be more room for exclusion criteria such as that in this research.

It is important to note that the interview guide used for CPs was the same guide used for TPs. This effected CP responses as the questions were sometimes hard to answer based on the fact that they were to be directed at intimate details of someone's life. While CPs were able to make inferences based on their experiences in most cases, some questions were too specific or too broad, affecting the guide's reliability.

Implications

While the results from this study are not generalizable, they do present some findings that may be of interest when considering practice methods among clinicians. Two primary practice implications from this research include identifying (and treatment of) IAD, as well as

considering IAD when conducting assessments. CPs in this research identify that this isn't the first foray into treatment for many of the clients they are serving. As CP6 points out: "...99% of clients have been treated for years for something else". This research's findings suggests it may be important for clinicians to begin considering the implications of technology and its effects on clients. By reading relevant literature and assessing new clients for IAD, clinicians may come to gain both practical and anecdotal methods for treating such a budding phenomenon.

When conducting new assessments (especially in cases of depressed or isolated clients), clinicians may benefit from evaluating time spent in front of screens, how often a client uses various technologies, and how invested they are in their technologies. Evidence from other research suggests there are correlations between technology use and variables including various problem behaviors (such as aggression, delinquency, withdrawal, anxiety, impulsivity, and lower social competence; Gentile et al., 2011; Holtz & Appel, 2011), family cohesion (Han et al., 2012; Siomos et al., 2012; Yen et al., 2007), and altered neurophysiology (Han et al., 2011; Han et al., 2012; Hou et al., 2012; Kim et al., 2011; Ko et al., 2009; Small et al., 2009; Zhou et al., 2011). Clinicians may want to consider evaluating technology use patterns amongst clients amidst a crisis in any, or all three of these areas.

Key Findings for Future Research and Conclusion

There were five areas where this research yielded interesting results that future researchers may want to consider. While interesting, these results are not generalizable to any population given the limited size of this study.

Parental architecture changes? It has become increasingly typical for both parents in modern families to work in order to support their family. While this wasn't the case for either TP, CPs reported a common trend they're seeing where one (typically the father by CP reports)

or both parents have high-profile jobs, meaning less child-parent interaction, more hands-off parenting. The parent who isn't working (typically the mother by CP reports) is often described as a helicopter-parent, more hands-on parenting. Additionally, in past generations exploration and development of autonomy that engenders secure attachments in teens (Kerns, 2008) was a more natural process because teens would leave their home on a given evening, and wouldn't be able to access their parents without a landline. With the advent of cell phones becoming more affordable than ever, more parents are now presented with the decision as to whether or not they want their children to have mobile technology. Researchers may want to consider looking at the effects of helicopter parenting on individuals younger than 18 years of age. Additionally, future research may examine whether there is a correlation between helicopter-parents, teens being equipped with cell phones (by their parents), and attachment styles. Furthermore, one must consider whether a parent can afford to buy their teen a cell-phone. Researchers may want to consider if any perceived effects remain true across socio-economic populations, or if the app-gap (Common Sense Media, 2011) holds true in this case as well.

Undermining the GCP? Kerns (2008) states the importance of the GCP while also reminding readers that it is difficult to measure the GCP due to the increasing complexities of measuring attachment after four years of age. One of the biggest advantages to modern technology (i.e. the ability to connect with another person from just about anywhere, at just about any time) can undermine the quality of child attachment development if used improperly, as participants from this research have suggested. The trend of helicopter-parents is one that denies children and parents the experience of allowing children to experience a full range of emotions, and the opportunity to learn how to tolerate such emotions.

Me-llennials? The millennial generation has been mastering newer technologies at a faster clip than any previous generations, so much so that this modern generation gap is identified by 79% of the public as: "...mostly about the different ways old and young use technology" (Pew Research Center, 2010, p.7). Given technology's critical role in society, and the millennial generation's mastery of its many forms; there has been a changing of the guard in terms of who's-teaching-who how to use new and important technology. A young individual whom believes himself to be more adept than his parents at utilizing such an important instrument in our society may experience feelings of grandeur. Future research exploring this may want to examine variables such as when individuals began first using technology, did they teach their parents or other family members how to use it, and measure these variables against the presence of narcissistic traits.

How to treat IAD? Exploring how clinicians are treating IAD is an interesting consideration for future research. Of the six people interviewed, all inferred that there is life after technology addiction. CP7 poignantly highlighted how the therapeutic approach taken depends on the severity of IAD, treatment measures and interventions vary depending on severity. The fact that the DSM-V has labeled Internet Gaming Disorder as an area for further research (American Psychological Association, 2013) suggests that this is something clinicians should start paying attention to. CPs from this study forewarn that improper treatment likely won't produce desirable results. Clinicians may want to consider examining areas of technology use in their intakes and assessment, especially with children. Looking at variables such as number of hours spent in front of screens or using other technology, regardless of whether it's being used for work or recreation.

Conclusion. This research illuminated some fascinating tenets of the emerging phenomenon of IAD. Unfortunately the small sample size of the research limits its implications; however, due to the lack of qualitative data relative to IAD, the findings in this research may shed some light on future directions for IAD research. This research supplemented by the current and emerging literature on the subject seems to indicate that there is a significant change in the way that Millennials are utilizing technology. It seems that it would be wise for clinicians to start considering its impact. As CP6 reported:

We see a lot of really, really bad, *bad*, stuff! You know, it's not their fault, it's not the family's fault. It's just we see this entrenchment in the wrong treatment, and the wrong diagnoses...So it's really not just about getting help, it's really about getting the right kind of help.

CP6 highlights an important point: none of these families wanted this outcome.

Technology is often used with the best of intentions. Helicopter-parents merely want their child to be safe and successful. The vicious-cycle starts because parents want their teens to be happy, productive members of society. Parents give their children learning technology such as Baby Einstein because they want their kids to be intelligent. Kids are using social technology more and more because they can connect with more people than they'd ever hope to meet in a lifetime. The use of technology doesn't need to stop (nor will it ever at this rate), and it isn't necessarily a bad thing; but it is something to consider managing. Like so many other things in life, it should be taken in moderation.

References

- A history of Windows. (2013). Retrieved June 15, 2013, from <http://windows.microsoft.com/en-US/windows/history>
- Ainsworth, M. D. S. (1990). Some considerations regarding theory and assessment relevant to attachments beyond infancy. In Greenberg, M. T., Cicchetti, D., & Cummings, E. M. (Eds.), *Attachment in the preschool years: Theory, research, and intervention* (pp. 463-488). Chicago, IL: University of Chicago Press.
- Alzahabi, R., & Bekcer, M. W. (2013, February 11). The association between media multitasking, task-switching, and dual-task performance. *Journal of Experimental Psychology: Human Perception and Performance*. Advance online publication. doi: 10.1037/a0031208.
- Allen, J.P. (2008) The attachment system in adolescence. In J. Cassidy & P.R. Shaver (2nd ed.), *Handbook of attachment* (419-435). New York: The Guilford Press.
- Altimari, D., Mahony, M. H., & Lender, J. (2012, December 19). Sandy Hook shooter Lanza left little for investigators to trace. *The Hartford Courant*. Retrieved June 15, 2013, from <http://www.courant.com/news/connecticut/newtown-sandy-hook-school-shooting/hc-lanza-ghost-20121219,0,359337.story>
- American Psychological Association. (2013). *Diagnostic and Statistical Manual of Mental Disorders* (5th ed). Arlington, VA: American Psychiatric Association.
- Anderson, N. (2006, July 6). "Google" declared a verb. *Uncategorized*. Retrieved June 15, 2013, from <http://arstechnica.com/uncategorized/2006/07/7198-2/>
- Bartholomew, K. (1990). Avoidance of intimacy: An attachment perspective. *Journal of Social and Personal Relationships*, 7, 147-178.

- Barone, L., & Lionetti, F. (2011). Attachment and emotional understanding: A study on late-adopted pre-schoolers and their parents. *Child: Care, Health, and Development*, 38(5), 690-696. doi: 10.1177/0265407590072001
- Beaumont, C. (2009, January 16). New York plane crash: Twitter breaks the news, again. *The Telegraph*. Retrieved June 15, 2013, from <http://www.telegraph.co.uk/technology/twitter/4269765/New-York-plane-crash-Twitter-breaks-the-news-again.html>
- Blankenhorn, D. (2008). Foreword: The crisis in American childhood. In *Authoritative communities: The scientific case for nurturing the whole child* (xiii-xv). New York, NY: Springer Science and Business Media.
- Broadcasting timeline. (2007). Retrieved June 15, 2013, from <http://www.infoplease.com/ipea/A0151956.html>
- Cain, G. (2010, April 20). South Korea cracks down on gaming addiction. *Time*. Retrieved June 15, 2013, from: <http://www.time.com/time/world/article/0,8599,1983234,00.html>
- Carr, N. (2011). *The shallows: What the internet is doing to our brains*. New York, NY: W. W. Norton & Company.
- Cash, H., McDaniel, K. (2008). *Video games & your kids: How parents stay in control*. Enumclaw, WA: Idyll Arbor.
- Christakis, D. A. (2008). The effects of infant media usage: What do we know and what should we learn? *Acta Paediatrica*, 98(1), 8-16.
- Common Cause. (2005). The fallout from the telecommunications act of 1996: Unintended consequences and lessons learned. Retrieved June 15, 2013, from http://www.commoncause.org/atf/cf/%7BFB3C17E2-CDD1-4DF6-92BE-BD4429893665%7D/FALLOUT_FROM_THE_TELECOMM_ACT_5-9-05.PDF

- Common Sense Media. (2011). Zero to eight: children's media use in America. USA: Common Sense Media. Retrieved from Common Sense Media website:
<http://www.commonsensemedia.org/sites/default/files/research/zerotoeightfinal2011.pdf>
- Company history. (n.d.). Retrieved June 15, 2013, from <http://www.nintendo.com/corp/history.jsp>
- Connor, T. (2013, January 22). New Mexico teen accused of family slaughter loved 'violent' video games, police say. *U.S. News*. Retrieved June 15, 2013, from http://usnews.nbcnews.com/_news/2013/01/22/16643356-new-mexico-teen-accused-of-family-slaughter-loved-violent-video-games-police-say?lite
- Cozolino, L. J. (2nd ed.) (2002). *The neuroscience of psychotherapy: Building and rebuilding the human Brain*. New York, NY: W W Norton & Company.
- Cozolino, L. (2006). *The Neuroscience of human relationships: Attachment and the developing social brain*. New York, NY: W. W. Norton & Company.
- Cozolino, L. J. (2010). *The neuroscience of psychotherapy: Healing the social brain*. New York, NY: W. W. Norton & Company.
- Curtis, A. (2013). The brief history of social media. Retrieved June 15, 2013, from <http://www.uncp.edu/home/acurtis/NewMedia/SocialMedia/SocialMediaHistory.html>
- DeAngelis, T. (2008, May 4). Is internet addiction real? *American Medical Network*. Retrieved June 15, 2013, from <http://www.health.am/psy/more/is-internet-addiction-real/>
- Doan, A. (2012a). *Hooked on games*. Coralville, IA: F. E. P. International.
- Doan, A. (Producer). (2012b, October 2). Technology, video games, social media, and your children's brain. *The Biggest 24 & Hooked on Games: Harnessing Your Full Potential in the Digital Age*. Podcast retrieved from: <http://www.andrew-doan.com/podcasts.html>

- Dong, G., Huang, J., & Du, X. (2011). Enhanced reward sensitivity and decreased loss sensitivity in internet addicts: An fMRI study during a guessing task. *Journal of Psychiatric Research*, 45, 1525-1529. doi:10.1016/j.jpsychires.2011.06.017
- Dunckley, V.L. (2013, January 12). Teens, screens, and metabolic syndrome. *Psychology Today*. Retrieved June 15, 2013, from <http://www.psychologytoday.com/blog/mental-wealth/201301/teens-screens-and-metabolic-syndrome>
- Eagle, M. (1995). The developmental perspectives of attachment and psychoanalytic theory. In Goldberg, S., Muir, R., & Kerr, J, *Attachment Theory: Social, Developmental, and Clinical Perspectives* (pp. 123-150). Hillsdale, NJ: The Analytic Press.
- Farber, B. A., Shafron, G., Hamadani, J., Wald, E., & Nitzburg, G. (2012). Children, technology, problems, and preferences. *Journal of Clinical Psychology: In Session*, 68(11), 1225-1229. doi: 10.1002/jclp.21922
- Feeney, B. C. & Monin, J. K. (2008) An attachment-theoretical perspective on divorce. In J. Cassidy & P.R. Shaver (2nd ed.), *Handbook of attachment* (419-435). New York: The Guilford Press.
- Fingerman, K. L., Chen, Y. P., Wesselmann, E. D., Zarit, S., Furstenberg, F., Birditt, K. S. (2012). Helicopter parents and landing pad kids: Intense parental support of grown children. *Journal of Marriage and Family* 74(4), 880-896.
- Flisher, C. (2010). Getting plugged in: an overview of internet addiction. *Journal of Pediatrics and Child Health*, 46(10), 557-559. doi:10.1111/j.1440-1754.2010.01879.x
- Fonagy, P. & Target, M. (2005). Bridging the transmission gap: An end to an important mystery of attachment research? *Attachment & Human Development*, 7(3), 333-343. doi: 10.1080/14616730500269278

- Gentile, D. (2009). Pathological video game-use among youth ages 8 to 18. *Psychological Science*, 20(5), 594-602.
- Gentile, D. A., Choo, H., Liau, A., Sim, T., Li, D., Fung, D., & Khoo, A. (2011). Pathological video game use among youths: A two-year longitudinal study. *Pediatrics*, 127(2), e319-e328. doi: 10.1542/peds.2010-1353
- Gibbs, N. & Roche T. (1999, December 20). The Columbine tapes. Retrieved June 15, 2013, from <http://www.time.com/time/magazine/article/0,9171,992873,00.html>
- Goldstein, S., & Thau, S. (2011). A brain-based understanding from the cradle to the grave. In Dunham, S. M., Dermer, S. B., & Carlson, J., *Poisonous Parenting* (63-79). New York: Taylor and Francis Group.
- Green, R. L., & Ostrander, R. L., (2009). *Neuroanatomy for Students of Behavioral Disorders*. New York: W. W. Norton & Company.
- Han, D., Bolo, N., Daniels, M. A., Arenella, L., Lyoo, I., Renshaw, P. F. (2011). Brain activity and desire for internet game play. *Comprehensive Psychiatry*, 52. 88-95. doi: 10.1016/j.comppsy.2010.04.004
- Han, D., Kim, S., Lee, Y., & Renshaw, P. F. (2012). The effect of family therapy on the changes in the severity of on-line game play and brain activity in adolescents with on-line game addiction. *Psychiatry Research: Neuroimaging* 202(2), 126-131. doi: 10.1016/j.psychresns.2012.02.011
- Han, D., Lyoo, I., & Renshaw, P. F. (2012). Differential regional gray matter volumes in patients with on-line game addiction and professional gamers. *Journal of Psychiatric Research*, 46, 507-515. doi: 10.1016/j.psychires.2012.01.004

- Historical periods in television technology. (n.d.). Retrieved June 15, 2013, from <http://transition.fcc.gov/omd/history/tv/>
- Holtz, P., & Appel, M. (2011). Internet use and video gaming predict problem behavior in early adolescence. *Journal of Adolescence*, *34*(1), 49-58. doi: 10.1016/j.adolescence.2010.02.004
- Hoover, A. & Krishnamurti, S. (2010). Survey of college students' mp3 listening: Habits, safety issues, attitudes and education. *American Journal of Audiology*, *19*, 73-83.
- Hou, H., Jia, S., Hu, S., Fan, R., Sun, W., Sun, T., Zhang, H. (2012). Reduced striatal dopamine transporters in people with internet addiction disorder. *Journal of Biomedicine and Biotechnology*, *2012*, 1-5. doi: 10.1155/2012/854524
- Hunt, D. (2010, October 27). Jacksonville mom shakes baby for interrupting FarmVille, pleads guilty to murder. *The Florida Times-Union*. Retrieved June 15, 2013, from <http://jacksonville.com/news/crime/2010-10-27/story/jacksonville-mom-shakes-baby-interrupting-farmville-pleads-guilty-murder>
- iPod + iTunes timeline. (n.d.). Retrieved June 15, 2013, from <http://www.apple.com/pr/products/ipodhistory/>
- Kent, S.L. (2001). *The ultimate history of video games*. Roseville, CA: Prima Publishing.
- Kerns, K. A. (2008). Attachment in middle childhood. In J. Cassidy & P.R. Shaver (2nd ed.), *Handbook of attachment* (366-382). New York: The Guilford Press.
- Kim, S., Baik, S., Park, C., Kim, S., Choi, S., & Kim, S. (2011). Reduced striatal dopamine d2 receptors in people with internet addiction. *Neuroreport*, *22*(8). 407-411. doi: 10.1097/WNR.0b013e328346e16e

- Ko, C., Liu, G., Hsiao, S., Yen, J., Yang, M., Lin, W., . . . , Chen, C. (2009). Brain activities associated with gaming urge of online gaming addiction. *Journal of Psychiatric Research, 43*, 739-747. doi: 10.1016/j.psychires.2008.09.012
- Kohler, C. (2009). July 29, 1994: Videogame makers propose ratings board to congress. *Wired*. Retrieved June 15, 2013, from http://www.wired.com/thisdayintech/2009/07/dayintech_0729/
- Kuss, D. J., & Griffiths, M. D., (2012). Online gaming addiction in children and adolescents: a review of empirical research. *Journal of Behavioral Addiction, 1*(1), 1-20. doi: 10.1556/JBA.1.2012.1.1
- Kuss, D. J., van Rooij, A. J., Shorter, G. W., Griffiths, M. D., & van de Mheen, D (2013). Internet addiction in adolescents: Prevalence and risk factors. *Computers in Human Behavior, 29*(5), 1987-1996. doi: 10.1016/j.chb.2013.04.002
- Lapidot-Lefler, N. & Barak, A. (2012). Effects of anonymity, invisibility, and lack of eye-contact on toxic online-disinhibition. *Computers in Human Behavior, 28*, 434-443. doi:10.1016/j.chb.2011.10.014
- Lewis, T., Amini, F., & Lannon, R. (2000). *A general theory of love*. New York: Random House.
- Lee, D. (2013, May 9). *World of Warcraft subscribers are leaving, Activision warns*. Retrieved June 15, 2013, from <http://www.bbc.co.uk/news/technology-22464058>
- Littler, C., (2011). 10 most-watched television finales of all time. Retrieved June 15, 2013, from <http://blog.koldcast.tv/2011/koldcast-news/10-most-watched-television-finales-of-all-time/>

- Liu, C. & Kuo, F. (2007). A study of internet addiction through the lens of interpersonal theory. *Cyberpsychology and Behavior*, 10(6), 799-804. doi: 10.1089/cpb.2007.9951
- Madden, M. (2009). The state of music online: Ten years after Napster. Retrieved from Pew Internet & American Life Project website: http://www.pewinternet.org/~media/Files/Reports/2009/The-State-of-Music-Online_-Ten-Years-After-Napster.pdf
- Main, M. (n.d.) *Adult attachment interview protocol*. Retrieved June 15, 2013, from http://www.psychology.sunysb.edu/attachment/measures/content/aai_interview.pdf
- Marvin, R. S., & Britner, P, A. (2008). Normative development. In J. Cassidy & P.R. Shaver (2nd ed.), *Handbook of attachment* (pp. 269-294). New York: The Guilford Press.
- McCabe, G. (2013, May 3). 13-year-old slashes pal's throat after falling out over violent video game Gears of War 3. *Daily Record*. Retrieved June 15, 2013, from <http://www.dailyrecord.co.uk/news/scottish-news/xbox-live-gears-war-3-1866681>
- McCarthy, C. (2009, January 13). Murder conviction for teen in 'Halo' case. *Cnet*. Retrieved June 15, 2013, from http://news.cnet.com/8301-10797_3-10141467-235.html
- Montgomery, N. (2010, October 11). Parents protecting their investments. *The New York Times*. Retrieved June 15, 2013, from <http://www.nytimes.com/roomfordebate/2010/10/11/have-college-freshmen-changed/parents-protecting-their-investments>
- Mortenson, E., (2008, May 18). Thurston shooting 10 years later. *The Oregonian*. Retrieved June 15, 2013, from <http://www.oregonlive.com/news/oregonian/index.ssf?/base/news/1210994708185180.xml&coll=7>
- Murchinson, J. (2006, October 9). Google to acquire YouTube for \$1.65 billion in stock. Retrieved June 15, 2013, from http://googlepress.blogspot.com/2006/10/google-to-acquire-youtube-for-165_09.html

Nielson. (2012, February, 16). American families see tablet as playmate, teacher, and babysitter.

Nielson. Retrieved June 15, 2013, from <http://www.nielson.com/us/en/newswire/2012/american-families-see-tablets-as-playmate-teacher-and-babysitter.html>

Number of World of Warcraft subscribers from 1st quarter 2005 to 1st quarter 2013. (2013).

Retrieved June 15, 2013, from <http://www.statista.com/statistics/208146/number-of-subscribers-of-world-of-warcraft/>

Our history in depth. (n.d.). Retrieved June 15, 2013, from <http://www.google.com/about/company/history/>

Paakkinen, J., (1999, December 23). A brief history of the Simpsons. Retrieved June 15, 2013, from <http://www.snpp.com/other/articles/briefhistory.html>

Padilla-Walker, L. M. & Nelson, L. J. (2012). Black hawk down? Establishing helicopter parenting as a distinct construct from other forms of parental control during emerging adulthood. *Journal of Adolescence*, 35(5), 1177-1190. doi: 10.1016/j.adolescence.2012.03.007

Pace, C. S., & Zavattini, G. C. (2010). 'Adoption and attachment theory' the attachment models of adoptive mothers and the revision of attachment patterns of their late-adopted children. *Child: Care, Health, and Development*, 37(1), 82-88. doi:10.1111/j.1365-2214.2010.01135.x

Patterson, C.J. (2006). Children of lesbian and gay parents. *Current Directions in Psychological Science*, 15(5), 241-244.

Pew Research Center. (2010). *Millennials: Confident. Connected. Open to change*. Retrieved from Pew Research website: <http://www.pewsocialtrends.org/files/2010/10/millennials-confident-connected-open-to-change.pdf>

Pink, D. H. (2009). *Drive*. New York: The Penguin Group.

Quigley, R. & Farberov, S. (2013, May 3). 'I killed my mom with my .22. I don't know why I did it.': Chilling 911 call reveals 13-year-old boy admitting he tried to rape and then shoot dead his mom 'for taking away his Call of Duty game'. *The Daily Mail*. Retrieved June 15, 2013, from <http://www.dailymail.co.uk/news/article-2319064/Noah-Crooks-Chilling-911-reveals-13-year-old-boy-admitting-tried-rape-shot-dead-mom-taking-away-video-game.html>

Ramey, C. R. (2007). *Mass media unleashed*. Lanham, MD: Rowman & Littlefield Publishers.

Richtel, M., (2011, October 22). A silicon valley school that doesn't compute. *The New York Times*. Retrieved June 15, 2013, from http://www.nytimes.com/2011/10/23/technology/at-waldorf-school-in-silicon-valley-technology-can-wait.html?_r=0

Richtel, M. (2012, November 1). Technology changing how students learn, teachers say. *The New York Times*. Retrieved June 15, 2013, from http://www.nytimes.com/2012/11/01/education/technology-is-changing-how-students-learn-teachers-say.html?pagewanted=all&_r=0

Riot Games to summon League of Legends [press release]. (2008, October 7). Retrieved June 15, 2013, from http://www.riotgames.com/sites/default/files/uploads/080907_NEWS_lol_lollaunch2009.pdf

The major league [of legends]. (n.d.). Retrieved from:

http://majorleagueoflegends.s3.amazonaws.com/lol_infographic.png

Rosen, L. (2012). *iDisorder*. New York, NY: Palgrave Macmillan.

S. 1823--103rd Congress: Video Game Rating Act of 1994. (1994). Retrieved from: [http://thomas.loc.gov/cgi-bin/query/z?c103:S.1823.IS:](http://thomas.loc.gov/cgi-bin/query/z?c103:S.1823.IS)

- Schore, A. (2012). *The science of the art of psychotherapy*. New York, NY: W. W. Norton & Company
- Schiffrrin, H. H., Liss, M., Miles-McLean, H., Geary, K. A., Erchull, M. J., & Tashner, T. (2013). Helping or hovering? The effects of helicopter parenting on college students well-being. *Journal of Child and Family Studies*, doi:10.1007/s10826-013-9716-3.
- Shaver, P. R. & Fraley, R. C. (1997). *Self-report measures of adult attachment*. Retrieved June 15, 2013, from <http://internal.psychology.illinois.edu/~rcfraley/measures/measures.html>
- Shilkret, R., & Shilkret, C. (2008). Attachment theory. In: J. Berzoff, L. M. Flanagan, & P. Hertz (2nd ed.), *Inside out and outside in* (pp. 189-203). New York: Jason Aaronson.
- Siomos, K., Floros, G., Fisoun, V., Evaggelia, D., Farkonas, N., Sergeantani, E. ... Geroukalis, D. (2012). Evolution of internet addiction in Greek adolescent students over a two-year period: The impact of parental bonding. *European Child & Adolescent Psychiatry*, 21, 211-219. doi: 10.1007/s00787-012-0254-0
- Skipworth, H. (2011, November 15). Xbox is 10 today - We celebrate its history. *Pocketlint*. Retrieved June 15, 2013, from <http://www.pocket-lint.com/news/112974-xbox-10th-anniversary-history>
- Small, G.W., Moody, T.D., Siddarth, P., & Bookheimer, S.Y. (2009). Your brain on Google: Patterns of cerebral activation during internet searching. *The American Journal of Geriatric Psychiatry*, 17(2), 116-126.
- Stein, J. (2013, May 9). Millennials: The me me me generation. Retrieved June 15, 2013, from <http://www.time.com/time/magazine/article/0,9171,2143001,00.html>
- Stoll, Clifford. (1995, February 16). The internet? Bah!. Retrieved from: <http://www.thedailybeast.com/newsweek/1995/02/26/the-internet-bah.html>

- Strauss, Paul. (2007, February 8). History of music players. *Technabob*. Retrieved from:
<http://technabob.com/blog/2007/02/08/a-brief-history-of-portable-media-players/>
- Tao, R., Huang, X., Wang, J., Zhang, H., Zhang, Y., & Li, M., (2010). Proposed diagnostic criteria for internet addiction. *Addiction*, *105*(3). 556-564. doi:10.1111/j.1360-0443.2009.02828.x
- Technology timeline: 1752-1990. (n.d.). Retrieved June 15, 2013, from http://www.pbs.org/wgbh/amex/telephone/timeline/timeline_text.html
- Television in the United States. (2013). In *Encyclopedia Britannica*. Retrieved June 15, 2013, from <http://www.britannica.com/EBchecked/topic/1513870/Television-in-the-United-States/283651/Conglomerates-and-codes>
- Temple, K (2012, March 13). What happens in an internet minute? *Intel inside scoop*. Retrieved June 15, 2013, from <http://scoop.intel.com/what-happens-in-an-internet-minute/>
- Timeline of computer history. (2006). Retrieved June 15, 2013, from <http://www.computerhistory.org/timeline/>
- Timeline of computing. (2006). Retrieved June 15, 2013, from <http://www.thocp.net/timeline/timeline.htm>
- Top 15 most popular social networking sites. (2013). Retrieved June 15, 2013, from <http://www.ebizmba.com/articles/social-networking-websites>
- Tsai, H., Cheng, S., Yeh, T., Shih, C., Chen, K., Yang, Y., & Yang, Y. (2009). The risk factors of internet addiction - A survey of university freshman. *PsychiatryResearch*, *167*(3), 294-299. doi: 10.1016/j.psychres.2008.01.015

- Turkle, S. (2011). *Alone together: Why we expect more from technology and less from each other*. New York, NY: Basic Books.
- Uhelszki, J. (2000, April, 13). Metallica sue Napster for copyright infringement. *Rolling Stone*. Retrieved June 15, 2013, from <http://www.rollingstone.com/music/news/metallica-sue-napster-for-copyright-infringement-20000413>
- United Press International. (1981, November 19). Marcos bans video games. *The New York Times*. Retrieved June 15, 2013, from <http://www.nytimes.com/1981/11/20/world/marcos-bans-video-games.html>
- van Eijnden, R. M., Spijkerman, R., Vermulst, A. A., van Rooij, T. J., & Engels, R. E. (2010). Compulsive internet use among adolescents: Bidirectional parent-child relationships. *Journal of Abnormal Child Psychology*, 38(1), 77-89. doi: 10.1007/s10802-009-9347-8
- Walton, A.G. (2012, October, 2). Internet addiction: The new mental health disorder? *Forbes*. Retrieved June 15, 2013, from <http://www.forbes.com/sites/alicegwalton/2012/10/02/the-new-mental-health-disorder-internet-addiction/>
- Ward, V. (2013, April 21). Toddlers become so addicted to iPads they require therapy. *The Telegraph*. Retrieved June 15, 2013, from <http://www.telegraph.co.uk/technology/10008707/Toddlers-becoming-so-addicted-to-iPads-they-require-therapy.html>
- Whang, L. S. M., Lee, S., Chang, G. (2003). Internet over-users' psychological profiles: A behavior sampling analysis on internet addiction. *Cyberpsychology & Behavior*, 6(2), 143-150.
- Willenz, P., 2010. American psychological association reiterates support for same-sex marriage. American Psychological Association. Retrieved June 15, 2013, from <http://www.apa.org/news/press/releases/2010/08/support-same-sex-marriage.aspx>

- Yen, J., Yen, C., Chen, C., Chen, S., & Ko, C. (2007). Family factors of internet addiction and substance use experience in Taiwanese Adolescents. *Cyberpsychology & Behavior*, *10*(3), 323-329. doi: 10.1089/cpb.2006.9948
- Yin, C., & Wangshu, L. (2013, February 22). Plan to tackle internet addiction. *China Daily*. Retrieved June 15, 2013, from http://www.chinadaily.com.cn/cndy/2013-02/22/content_16246094.htm
- Your two year old. (n.d.). Retrieved June 15, 2013, from <http://www.pbs.org/parents/childdevelopmenttracker/two/>
- Zhou, Y., Lin, F., Du, Y., Qin, L., Zhao, Z., Xu, J., Lei, H. (2011). Gray matter abnormalities in internet addiction: A voxel-based morphometry study. *European Journal of Radiology*, *79*, 92-95. doi: 10.1016/j.ejrad.2009.10.025

Appendix A

HSR Approval

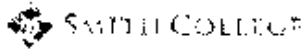

School for Social Work
Smith College
Northampton, Massachusetts 01063
Tel: (413) 535-7950 Fax: (413) 535-7991

January 24, 2013

David Sullivan

Dear David,

Thank you for making all the requested changes to your Human Subjects Review application. Your project is now approved by the Human Subjects Review Committee.

Please note the following requirements:

Consent Forms: All subjects should be given a copy of the consent form.

Maintaining Data: You must retain all data and other documents for at least three (3) years past completion of the research activity.

In addition, these requirements may also be applicable:

Amendments: If you wish to change any aspect of the study (such as design, procedures, consent forms, or subject population), please submit these changes to the Committee.

Renewal: You are required to apply for renewal of approval every year for as long as the study is active.

Completion: You are required to notify the Chair of the Human Subjects Review Committee when your study is completed (data collection finished). This requirement is met by completion of the thesis project during the Third Summer.

Good luck with your project.

Sincerely,

A handwritten signature in black ink, appearing to read "Marsha Klise Priset".

Marsha Klise Priset, M.S., Ph.D., M.S.J.
Vice Chair, Human Subjects Review Committee

CC: Colette Drecianova Wright, Research Advisor

Appendix B

Approval from reSTART for Recruitment



To Whom It May Concern:

This letter is to confirm that David Sullivan is approved to recruit participants for his research through reSTART.



Hilarie Cash, PhD, LMHC - Co-CEO



Date



Cosette Dawna Rae, MSW, LSWAIC - Co-CEO

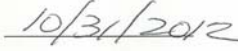

Date

reSTART Internet Addiction Recovery Program
1001 290th Ave SE, Fall City, WA 98024 | Tel: 800.682.6934 | Fax: 888.788.3419
restart@netaddictionrecovery.com | www.netaddictionrecovery.com

Appendix C

Approval from Insight Intensive for Recruitment



A Young Adult Men's Mentoring Program

connecting to life, meaning & purpose

February 13, 2013

To whom it may concern,

David Sullivan has permission to recruit participants for his thesis research at Insight Intensive.

Enjoy the Day,

Joseph A. DeNucci
Director and Co-Founder

A handwritten signature in black ink that reads "J. A. DeNucci". The signature is written in a cursive style with a large initial "J".

Insight Intensive at Gold Lake
3371 Gold Lake Road
Ward, Colorado 80481

Office 303 952 1420

Cell 520 906 9827

Fax 303 952 1443

www.insightintensive.com

Appendix D

Online Gamers Anonymous Email Approval to Recruit

Hello David,

Thank you for your note. I apologize for not responding sooner, but I do not have complete internet access right now.

You may ask parents to assist you with this. Please post your request in the Media Tab, Interview Requests. Here is a link to that section:

<http://www.olganon.org/?q=forum/144>

You will need to create a login to do this.

I would be willing to speak with you, as my son was addicted to the Everquest game and it really did affect our relationship in a very negative way.

Liz W.

Founder of On-Line Gamers Anonymous

OLGA for gamers

OLG-Anon for family members, friends, loved ones, concerned others

Hot-line [612-245-1115](tel:612-245-1115)

www.olganon.org

Email olga@olganon.org

Appendix E

List Serve Email Approval to Recruit

To Whom It May Concern:

David Sullivan has obtained approval to recruit participants for his research through my list serve.

Sincerely,

Hilarie Cash, PhD, LMHC

Co-CEO, reSTART: Internet Addiction Recovery Program

1001 290th Ave SE, Fall City, WA 98024-7403

Tel: [800-682-6934](tel:800-682-6934) Fax: [888-788-3419](tel:888-788-3419)

Appendix F

HSR Approval for Expansion of Recruitment



School for Social Work
Smith College
Northampton, Massachusetts 01063
T (413) 585-7950 F (413) 585-7994

April 25, 2013

David Sullivan
XXXXXXXXXX
XXXXXXXXXX

Dear David,

I have reviewed your amendment involving expanding your recruitment and it looks fine.

This amendment to your study is therefore approved. Thank you and best of luck with your project.

Sincerely,

Marsha Kline Pruett, M.S., Ph.D., M.S.L.
Acting Chair, Human Subjects Review Committee

CC: Colette Duciaume-Wright, Research Advisor

Appendix G

Sample Recruitment Letter

Hello! My name is David Sullivan. I am a graduate student from the Smith College School for Social Work (Northampton, MA). I am currently working on my master's thesis and need participants for my study. My research is exploring the impact of technology on the parent-child relationship. Specifically, I am interested in how people perceive that technology affected their upbringing, as well as what their parents' relationship with technology was like.

Your experience with technology prior to reSTART is of interest to me for my research. Participants in the study will take part in an individual phone interview with myself, responding to a series of questions. These interviews will take roughly 60 minutes of your time and take place during the month of February. In addition, participants in this research must meet the following criteria:

1. Are currently enrolled at, or have successfully graduated from the reSTART program
2. Be 18 years of age or older
3. Grew up in a two-parent household
4. Were not adopted

If you think that you meet the above criteria and that this research is something you would be interested in participating in, please contact me by either phone or email via the information below. Your decision whether or not to participate in my research will have no effect on your standing with the reSTART program.

Thank you for your consideration!

-David Sullivan
[phone number and email removed]

Appendix H

Sample Consent Form - Treatment Participants

[Date]

Hello former or current reSTART participant, and thank you for taking the time to participate in my research! I am a master's level graduate student attending the Smith College School for Social Work. I am exploring the impact of technology on the parent-child relationship. This study seeks to explore this topic through interviews regarding the participant's perception of their relationship with his/her parents, as well as the parents' relationship with technology. The data gathered from this research will be used for the purpose of completing my Master's thesis in social work, and possible publication and presentation.

I am requesting your participation based on your completion of, or current participation in the reSTART program. Participation in this research will require close to 60 minutes of your time for an informal interview. Should you choose to participate I will schedule a phone call for the interview. In the interest of confidentiality, crowded areas may not be appropriate given the attention the questions may require. I will be audio recording the interview with a program on my cell phone as well as a separate backup recording device, that converts the conversation to an audio file. Following the interview, I will transcribe the data onto my own personal laptop. In the case that I need to contact you to clarify anything, I will contact you by phone.

It is important to consider that by participating in this research, there are some risks involved. Discussing one's history and relationships with one's parents can stir up a variety of emotions. I recommend that you utilize the mental health resources I have provided with this letter should you need support following the interview. Unfortunately, I will not be able to

provide compensation for your participation in this research. Participation in this research may deepen your understanding of your family and childhood.

As mentioned above, all information provided to me in this research shall be held confidential. The information that is transcribed onto my laptop will be stored on a password protected external hard drive and a thumb drive as back up. These hard drives will be kept under lock and key for 3 years following the conclusion of my research. At the end of the 3rd year, these data will be destroyed or kept secure if needed for further review. Once I have completed using the data, it will be destroyed. Each person who participates in the study will be identified by a randomly assigned interview number which will allow me to identify you in my notes; however, outside of a few pieces of personal data that I will be collecting, there will be no way of connecting your transcripts with your identity. For the purposes of publications or presentations, data will be presented in aggregate, and when brief quotes or vignettes are used, they will be carefully disguised. My research advisor will assist with the examination of data, but only after all identifying information has been removed.

Participation in this research is voluntary. If at any time you do not wish to answer any question, you may refuse to do so. Should you wish to withdraw, you may contact me (by phone or email) any time prior to February 28th, 2013. All your data will be destroyed should you choose to withdraw. If you wish to discuss your rights as a participant you may contact the chair of the Smith College School for Social Work Human subjects review committee. If you have any questions regarding the study, you may contact me.

David Sullivan
Phone: [removed]
Email: [removed]

Smith School for Social Work
Human Subjects Review
Phone: 413.585.7974

YOUR SIGNATURE INDICATES THAT YOU HAVE READ AND UNDERSTAND THE ABOVE INFORMATION AND THAT YOU HAVE HAD THE OPPORTUNITY TO ASK

**QUESTIONS ABOUT THE STUDY, YOUR PARTICIPATION, AND YOUR RIGHTS
AND THAT YOU AGREE TO PARTICIPATE IN THE STUDY.**

Participant Signature

Researcher
David Sullivan

Printed Name

An extra copy of this information will be given to you. **PLEASE RETAIN THIS
INFORMATION IN YOUR PERSONAL RECORDS.**

Appendix I

Sample Consent Form - Clinical Participants

Hello reSTART staff, and thank you for taking the time to participate in my research! I am a master's level graduate student attending the Smith College School for Social Work. I am exploring the impact of technology on the parent-child relationship. This study seeks to explore this topic through interviews regarding clinical staff's perception of program participants' relationship with their parents, as well as their parents' relationship with technology. The data gathered from this research will be used for the purpose of completing my Master's thesis in social work, and possible publication and presentation.

I am requesting your participation based on your current work at the reSTART program. Participation in this research will require close to 60 minutes of your time for an informal interview. Should you choose to participate I will schedule a phone call for the interview. In the interest of confidentiality, crowded areas may not be appropriate given the attention the questions may require. I will be audio recording the interview with a program on my computer that converts the conversation to an audio file. Following the interview, I will transcribe the data onto my own personal laptop. In the case that I need to contact you to clarify anything, I will contact you by phone.

It is important to consider that by participating in this research, there are some risks involved. Discussing one's past work can stir up a variety of emotions. I recommend that you utilize the mental health resources I have provided with this letter should you need support following the interview. Unfortunately, I will not be able to provide compensation for your participation in this research. Participation in this research may deepen your understanding clients and their families.

As mentioned above, all information provided to me in this research shall be held confidential. The information that is transcribed onto my laptop will be stored on a password protected external hard drive and a thumb drive as back up. These hard drives will be kept under lock and key for 3 years following the conclusion of my research. At the end of the 3rd year, this data will be destroyed or kept secure if needed for further review. Once I have completed using the data, it will be destroyed. Each person who participates in the study will be identified by a randomly assigned interview number which will allow me to identify you in my notes; however, outside of a few pieces of personal data that I will be collecting, there will be no way of connecting your transcripts with your identity. For the purposes of publications or presentations, data will be presented in aggregate, and when brief quotes or vignettes are used, they will be carefully disguised. My research advisor will assist with the examination of data, but only after all identifying information has been removed.

Participation in this research is voluntary. If at any time you do not wish to answer any question, you may refuse to do so. Should you wish to withdraw, you may contact me by phone or email any time prior to May 10th, 2013. All your data will be destroyed should you choose to withdraw. If you wish to discuss your rights as a participant you may contact the chair of the Smith College School for Social Work Human subjects review committee. If you have any questions regarding the study, you may contact me.

David Sullivan
Phone: [removed]
Email: [removed]

Smith School for Social Work
Human Subjects Review
Phone: 413.585.7974

YOUR SIGNATURE INDICATES THAT YOU HAVE READ AND UNDERSTAND THE ABOVE INFORMATION AND THAT YOU HAVE HAD THE OPPORTUNITY TO ASK QUESTIONS ABOUT THE STUDY, YOUR PARTICIPATION, AND YOUR RIGHTS AND THAT YOU AGREE TO PARTICIPATE IN THE STUDY.

Participant Signature

Researcher
David Sullivan

Printed Name

An extra copy of this information will be given to you. **PLEASE RETAIN THIS
INFORMATION IN YOUR PERSONAL RECORDS.**

Appendix J

Interview Guide

- Remind them that they don't have to answer a question if they don't want to
- Define technology - screen and social technology: computers, TV, phones, video games, and recorded music
- Define growing up - 0-18 years old

1. Summarize how you perceive technology affected or influenced your life growing up?
2. How has technology enhanced or interrupted your relationship with your parents?
 - a. What role did technology play in your relationship with your parents? (i.e.-keep you occupied, education, play games)
 - b. Did you ever feel like you had to compete for attention with your parents' technology?
3. How do you remember your parents' relationship with technology?
 - a. Which of your parents used technology more, and how?
 - b. Did technology ever interfere with your parents' relationship with you, or with each other?
 - c. Choose 5 separate words, or short phrases to describe each of your parent's relationship with technology
4. Which of your parents were you closest with?
 - a. What shared interests brought you together?
 - b. Did this ever shift during your life, and if so, what influenced this shift?
 - c. Were there any other important people who influenced your life growing up?
5. What kind of rules or limits did you have around technology growing up?
6. What is the earliest memory you have of technology?
 - a. How old were you when you first started using technology?
 - i. What were you using it for?
7. How old were you when you first used the internet?
 - a. What sorts of activities do you remember using the internet for...
 - i. before high school
 - ii. during high school
 - b. And how did length of internet sessions fluctuate during those times?
8. What was your relationship to television growing up?
9. What kind of technology did you have in your bedroom growing up?
10. When you needed advice growing up, who or what would you usually turn to first?
 - a. Did you ever turn to technology for support? If so, how?
11. How were emotions handled in your family?
12. Given your experiences with technology, what do you wish more people understood about its current role in society?
13. What is the best advice you could give someone that struggles with technology abuse?

Appendix K

Sample Data Collection for Treatment Participants

Personal Information Form

The following questions are intended to gather personal information at the time of this study. You do not have to answer any questions that you are not comfortable answering.

- 1) What is your age? _____ years
- 2) How would you identify your race/ethnicity? _____
- 3) What is your gender? _____ Male
_____ Female
_____ Transgender (Place an "X" in the appropriate box)
_____ Other
_____ Prefer not to answer
- 4) Do you have any siblings? Yes No (Circle one)
If no, skip to question 4.
If Yes: _____ Older _____ Younger
How many?
- 5) In the past, which technology did you use most often?
(i.e. gaming, social media, etc.)

- 6) About how many hours did you spend using the following technology in a day, prior to attending reSTART?
_____ Television
_____ Laptop/Desktop Computer
_____ Cell Phone
_____ iPod or other mp3 player
- 7) How long have you been a participant in the reSTART program, or how long has it been since you completed the reSTART program?
_____ Weeks in reSTART
Or
_____ Months since graduating reSTART

These next four questions are meant to help understand your relationships with others. Answer questions 8-11 according to how you generally feel on most days.

8) It is relatively easy for me to become emotionally close to others.

1 2 3 4 5 6 7
← Strongly disagree Strongly Agree →

9) I often worry that other people don't really love me.

1 2 3 4 5 6 7
← Strongly disagree Strongly Agree →

10) I would rather take care of myself than depend on others.

1 2 3 4 5 6 7
← Strongly disagree Strongly Agree →

11) I am afraid to share myself personally or to receive disclosure from others.

1 2 3 4 5 6 7
← Strongly disagree Strongly Agree →

Appendix L

Sample Data Collection for Clinical Participants

Personal Information Form

The following questions are intended to gather personal information at the time of this study. You do not have to answer any questions that you are not comfortable answering.

- 1) What is your age? _____ years
- 2) How would you identify your race/ethnicity? _____
- 3) What is your gender? _____ Male
_____ Female
_____ Transgender (Place an "X" in the appropriate box)
_____ Other
_____ Prefer not to answer
- 4) What is your professional title? (i.e. therapist, case manager, etc.) _____
- 5) How many months have you worked at Insight Intensive? _____
- 6) Are you licensed in the state where you practice? Yes No
(Circle one)
- If so, what type of licensure? (i.e. LPC, LCSW, LMFT, etc) _____

- How many months have you been licensed? _____

Appendix M

Referrals for Research Participants

List of References

Below is a list of resources that you can contact should you need to discuss any uncomfortable feelings you still have following any part of participation during research.

1. Online Gamers Anonymous (OLGA): (612) 245-1115
 - What it is: A fellowship recovery model program that supports people with online gaming issues. OLGA is a 12-step community that has battled gaming addiction and seeks to help others battling this addiction.
 - Their website recommends using their online form for a response within 48 hours
 - <http://www.olganon.org/?q=contact>
2. NAMI Help Line: (800) 950-NAMI (6264)
 - What it is: Provides callers with general help regarding mental illness and recovery. The Help Line can answer questions regarding different types of mental illness, or assist callers in getting connected to a local office for a mental health referral.
 - Can also email at info@nami.org
 - Available Monday-Friday from 10am-6pm Eastern Time
3. Mental Health America: (800) 969-6642
 - What it is: Organization that supports those looking for mental health resources. Mental Health America educates, advocates for, and serves those looking for assistance with mental health and wellness.
 - Mental Health America runs a crisis line 24 hours a day, 7 days a week. If you find yourself in crisis, please call (800) 273-TALK (8255)