

***Arundo donax* as an energy crop: pros and cons of the utilization of this perennial plant**

Roberto Pilu^{1*}, Antonella Manca¹, Michela Landoni²

¹Dipartimento di Scienze Agrarie e Ambientali - Produzione, Territorio, Agroenergia, Università degli Studi di Milano, Via Celoria 2, 20133 Milano, Italy

²Dipartimento di Bioscienze, Università degli Studi di Milano, Via Celoria 26, 20133 Milano, Italy

*Corresponding author: E-mail: salvatore.pilu@unimi.it

Abstract

Arundo donax (giant reed) is a rhizomatous grass widely found in temperate and subtropical regions. Because of its capacity to grow vigorously in marginal land, it is considered as a dangerous weed plant. However, humans contributed to the dispersion of this plant around the world because *Arundo* is used for multiple purposes such as reeds in woodwind musical instruments, roof thatching and fishing rods. In recent years *A. donax*, due to its high biomass production has been also considered as a promising energy crop. Nevertheless, some important issues must be addressed. In fact, *A. donax* is a sterile plant and its propagation is based on vegetative propagation (fragmentation of rhizomes or canes) and *in vitro* culture, making establishing the crop on a large scale very expensive. Furthermore the geneticists cannot carry out conventional breeding programmes, so improvement will be based on ecotype selection, chemical and physical mutagenesis, and transgenesis techniques. Another aspect to consider for a massive utilization of *A. donax* as an energy crop consists in the scarcity of data on long-term field experiments, since the duration of the crop's life is 12-15 years. Hence, in this short review, we will bring together the principal pros and cons of this new putative energy crop.

Keywords: *Arundo donax*, vegetative propagation, energy crop, biomass

Introduction

In recent years, many national and international initiatives have started in order to identify new sources of renewable energy. This growing interest in renewable energy is driven by two main reasons. Firstly, fossil fuels such as oil, coal, and natural gas are limited resources on our planet and if the level of our consumption does not change, the estimated times of depletion of these energy sources will be approximately 50 years for oil, 70 years for natural gas, and 170 years for coal ([International Energy Outlook, 2006](#)). Secondly, the combustion of fossil fuels emits large amounts of gas into the atmosphere, increasing the natural greenhouse effect. Carbon dioxide (CO₂) and methane (CH₄) are the main components of greenhouse gases (GHGs). Since 1870, annual CO₂ emission from fuel combustion dramatically increased from near zero to 29 Gt in 2007 ([International Energy Agency, 2009](#)). In this context, the use of biomass for fuel is proposed as one of the options to reduce greenhouse gas (GHG) emissions. The European Commission encourages the use of biomass: the last directive from the EC states that the Member States of the EU should gradually increase the consumption of biomass and by 2020, 20% of EU energy consumption should be from renewable resources ([Directive 2009/28/EC](#)). In particular, in the European agricultural sector, the spread of non-food crops for energy production could provide a good opportunity for the integration of income margins (McKendry,

2002). In Europe, the cropping of high yield biomass plants (energy crops) on less rich land and fallows can provide farmers with a subsidized opportunity to diversify their production, increase their profit margins and hedge their financial risks without compromising the food supply (McKendry, 2002). In this mini review, we discuss the most important issues raised by a possible utilization of *Arundo donax* (Giant Reed) as source of renewable biomass for different purposes.

A. donax (giant reed cane) is an invasive perennial weed grass plant belonging to the Poaceae family of the Arundinae tribe, widely found in subtropical and warm temperate regions all over the world (see [Figure 1A](#)). The success of its diffusion is due to its spontaneous propagation by rhizome fragmentation and sprouting from the cane nodes (see [Figure 1B](#)), but also mostly, to its cultivation. In fact, the canes are used for many different purposes such as roof thatching, fishing rods, reeds in woodwind instruments, etc. ([Perdue, 1958](#); [Pilu et al, 2012](#)). It is one of the largest herbaceous grasses and even though *A. donax* is a C3 plant, it shows high photosynthetic rates and unsaturated photosynthetic potential in comparison with C4 plants ([Rossa et al, 1998](#)).

Its growth starts from the rhizome in early spring and reaches in late autumn the average height of more than 5 metres (see [Figure 1C](#)), having a growing rate of about 5 centimeters per day in the right environments ([Perdue, 1958](#); [Pilu et al, 2012](#)). In the past, *A. donax* was used within certain limits in indus-

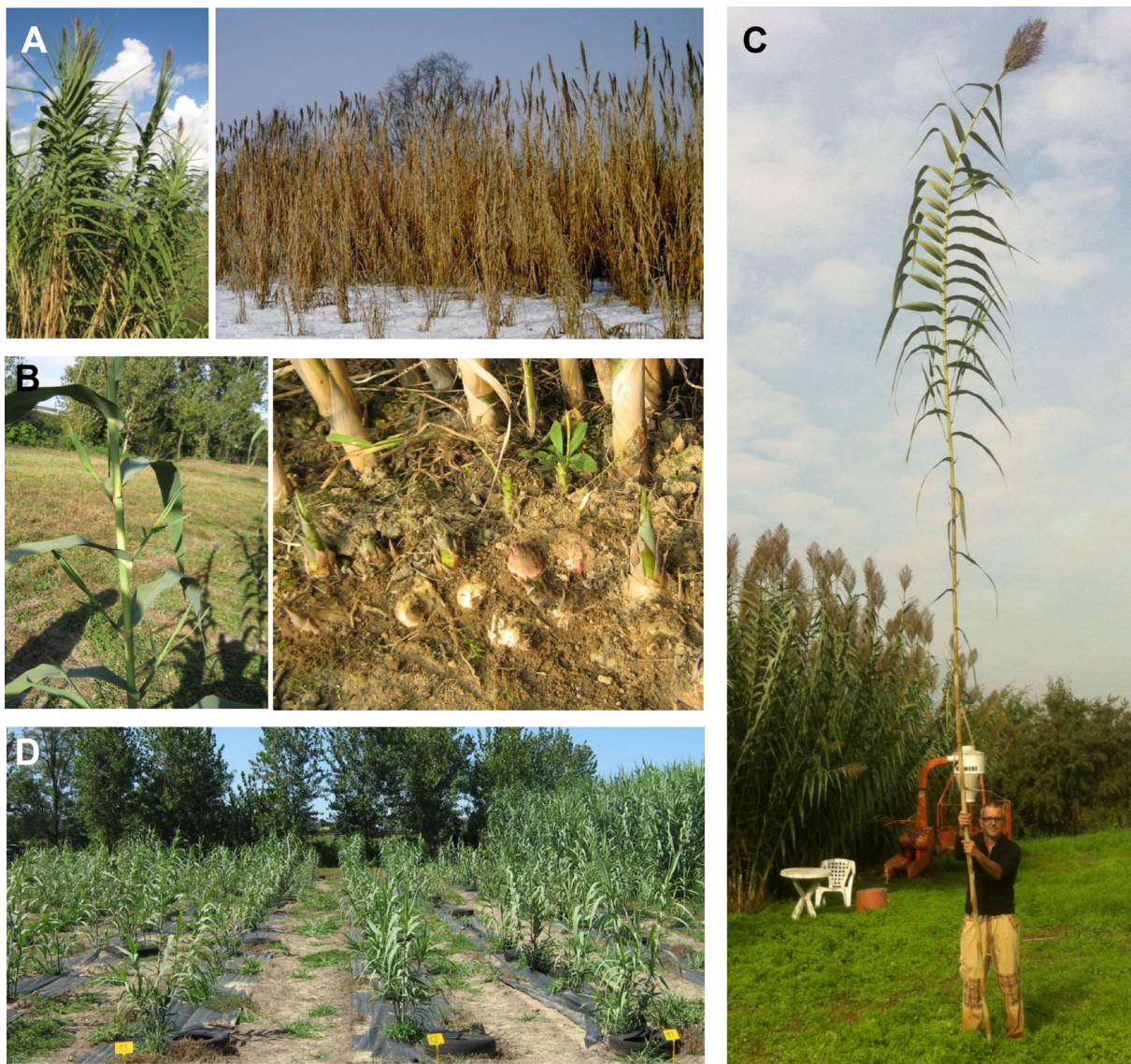

Figure 1 - Life cycle, propagation and culture of *A. donax*. (A) Mature plants in summer (left) and in the winter (right). (B) Propagation by shoots sprouting from canes (left) and from rhizome (right). (C) Single cane, reaching the height of 8 m, held by one of the authors. (D) Culture of *A. donax* by cane cuttings propagation (using mulch). The photos were taken in the experimental field of the University of Milano located in Landriano (45°18'N, 9°15'E).

trial processes to produce cellulose and other derivatives such as the textile fiber rayon, although it is also considered an invasive and dangerous weed plant in several countries (Perdue, 1958), and is included in a list of the 100 World's worst alien species (Lowe et al, 2000). The *A. donax* invasion has been observed mainly in riparian zones, but also in simplified ecosystems such as road-sides where it can colonize several kilometres, as observed for example in California and Southern Europe, damaging the native ecosystems and increasing the wildfire risk (Dudley, 2000). Despite these problems, in recent years *A. donax* aroused the interest of the scientific community because of its high potential in EROEI value (energy

returned on energy invested) compared with other energy crops. This fact is due to its great biomass productivity and that this species is also cropped in low input conditions (Angelini et al, 2009). If we consider that the length of cropping life of *A. donax* lasts about 12 to 15 years, without irrigation (with the exception of the first year), with a low fertilization (this question needs further research due to the scarcity of experimental data), without phytosanitary and weeding treatments, and that it is able to produce up to 60 t/hectare of dry matter in Central and Northern Italy (Angelini et al, 2005; Pilu et al, unpublished results), we can understand the reason why the interest of the crop has significantly aroused.

Results and Discussion

Despite it is able to produce an inflorescence (with thousands of hermaphrodite flowers) that can reach nearly one meter in length, *Arundo donax* is a sterile plant (Perdue, 1958; Mariani et al, 2010; Pilu et al, 2012). This inflorescence does not produce viable gametes and consequently seeds, due to the fact that giant reed appears to be a very recent species in grass phylogeny with uneven ploidy levels. *A. donax* originates from a cross between different species or/and from a phenomenon of polyploidization (Mariani et al, 2010; Pilu et al, 2012). The lack of sexual reproduction may be considered a good characteristic, thinking of *A. donax* as a weed plant and also as an energy crop (no dispersion of the seeds from the cultivated fields). Contrarily, the latter fact represents a problem because of the cost of the transplantation needed to obtain new fields, and also for the genetic improvement by breeding. Furthermore, molecular analysis carried out on different clones sampled in America and Europe did not show high levels of genetic variability (Ahmad et al, 2008; Mariani et al, 2010; Pilu et al, unpublished results) strongly restricting the possibility to perform clonal selection. Hence, to improve *A. donax* the techniques that could be used are mainly physical mutagenesis and genetic transformation methods to produce a genetically modified plant (Takahashi et al, 2010).

Arundo donax cell wall traits related to energy production

From the energy point of view, *A. donax* can be used to produce energy by direct combustion or to produce second generation biofuels, such as bioethanol, generated by alcoholic fermentation of lignocellulosic biomass pretreated to facilitate sugar release (Scordia et al, 2012). Of course, the pretreatment processes used to increase carbohydrate degradability (e.g. steam explosion, acid and heat treatment) consume energy. For this reason, a goal of the genetic improvement of *A. donax* and other grasses should also consist in the modification of cell wall composition in order to facilitate the use of the lignocellulose products in the biomass. The presence of phenolic compounds in the cell wall limits the carbohydrate degradability and consequently the energy value. The lignins, which are tightly associated to cell wall carbohydrates, thus prevent physical access of enzymes to cellulose and hemicelluloses and strongly limit their enzymatic hydrolysis. Cross linkages between lignins and arabinoxylans, and between arabinoxylan chains, through ferulate and diferulate bridges, also greatly impede cell wall degradability. Although *A. donax* is one of the tallest herbaceous plants, its lignin content is similar to that of other grass species, with an average value equal to 21%, while it equal to 19% in switchgrass, 20% in sugarcane, and 23% in miscanthus. The latter values are however still higher than in maize, with lignin content close to 11%. Lignins of *A. donax* are composed of guaiacyl

(G), syringyl (S), and p-hydroxyphenyl (H) units with an S/G ratio of 1.13 - 1.32 (Seca et al, 2000), which is a little lower value than in maize (Méchin et al, 2000). In fact, Jeon et al (2010) showed that little differences were noticed, for example, between sorghum straw and *A. donax* capabilities to produce ethanol after acid pretreatment and enzyme hydrolysis using *Zymomonas mobilis*. In another work, *A. donax*, elephantgrass (*Pennisetum purpureum*), miscanthus and sugarcane were compared for their capacity to produce bioethanol using cellulose solvent-based lignocellulose fractionation (CSLF) pretreatment and enzymatic (cellulase) hydrolysis (Ge et al, 2011). The results obtained showed no significant differences among these energy crops, consequently indicating that one of the most important parameters to be considered to optimize the EROEI value is the biomass production per hectare. Of course, another promising way to use these energy crops is through the direct anaerobic digestion of chopped biomass to produce biogas without any pretreatment. However, for both bioethanol and biogas production, a higher susceptibility of the biomass to pretreatments will allow the use of more environmentally friendly processes, lowering pollution and energy costs. Several mutations have been indeed shown to modify lignin content and structure, and plant degradability. Especially, brown-midrib mutants (bm mutants) investigated in maize (in particular *bm3* and *bm1*) and sorghum (*bmr6*, *bmr12*, and *bmr18*) increase the plant stover digestibility and/or saccharification properties (Barrière et al, 2004; Saballos et al, 2008, Sattler et al, 2010). For grass industrial uses, it has also been shown that such mutations could induce a greater susceptibility to pretreatments (Maehara et al, 2011; Wu et al, 2011). The latter fact strengthens the possibility of a breeding strategy based on induced mutations.

Arundo donax as a candidate plant for energy production

Taken together, these data suggest that *A. donax* could be considered a good candidate to supplement/replace maize, sorghum, and other energy crops used in particular to feed anaerobic digesters to produce green energy in Northern Italy, as it was recently reported by Schievano et al in 2012 (Table I). *A. donax* could thus be considered as the best candidate for cultivation in those Mediterranean areas characterized by 1800°C GDD (growth degree day) and useful rainfall equal at least of 300mm during the season. Another promising perennial energy crop that could be utilized is Miscanthus (*Miscanthus x giganteus*) a sterile, triploid interspecific hybrid, also needing vegetative propagation by rhizome fragmentation or *in vitro* cultures (Clifton-Brown et al, 2002). However, a comparison of *A. donax* and Miscanthus in a long-term field experiment (12 years) in Central Italy (Pisa) by Angelini et al (2009) showed a higher biomass production in the case of *A. donax* with a average biomass production of 37.7 tons of dry mat-

Table 1 - Comparison among maize, sorghum and *A. donax* as energy crops (modified from Schievano et al, 2012).

	Fresh matter yield (t ha ⁻¹)	Dry matter (%)	Dry matter yield (t ha ⁻¹)	Culture cost (Euros ha ⁻¹ year ⁻¹)
Maize	70	30	20	2,100
Sorghum	128	15	19	1,700
<i>A donax</i>	85 - 130†	42	36 - 55	700‡

†85 t ha⁻¹ in marginal lands and 130 t ha⁻¹ in fertile lands

‡considering a 15 years duration of the crop

ter per hectare and 28.7 t ha⁻¹ for *Miscanthus*. These results have been obtained without irrigation and by fertilizing every year with 100 kg P₂O₅ ha⁻¹, 100 kg K₂O ha⁻¹ and 100 kg N ha⁻¹ (Angelini et al, 2009). In another work conducted in Southern Italy by Cosentino et al (2005), a lower level of biomass production (22 t ha⁻¹) was reported for *A. donax*, probably due to the scarcity of rainfall.

Hence, in Northern Italy where there is often a high water table and a good summer rainfall, *A. donax* could be cultivated without irrigation (apart from the first year) and with a minimum or no chemical fertilization. Here we can consider the possibility to use instead as fertilizer the manure/digested matter that are considered as wastes of the agriculture in this region rich in cattle rearing and digesters.

Arundo donax propagation conditions and costs

We thus can conjecture that *A. donax* cultivation in these conditions could be the best choice for a crop destined for energy utilization, reaching potentially an annually cost of cultivation of about 700 euro ha⁻¹. The latter value takes into account the 15 years life span of the crop as reported in Table 1 and in details in Table 2, where the costs of the individual field operations are shown. In Table 2, we estimate the cost to be 0.5 euro per plant for *A. donax* propagules, as young plantlets in pots (this price is obtained by comparing with other cultures propagated in an agamic way). However, the real cost of these materials will be defined when a reproduction system on large scale is eventually used. Also the number of propagules per hectare is an important parameter to be taken into consideration. In fact, reports on field establishment rates vary from about 2,500 propagules per hectare to 10,000 - 20,000 propagules per hectare (Ceotto and Di Candilo, 2010). Hence, despite *A. donax* positive characteristics, the conditions of field establishment are important issues that must be resolved before the crop can be utilized on a large scale, i.e. how to propagate and “sow” this agamic plant in the fastest and cheapest way. So far, *A. donax* cultivation on a large scale does not exist, and the few experimental fields which exist have been mainly obtained by transplantation of rhizome fragments (usually with 10,000 rhizomes per hectare), making this procedure very expensive, with costs nearly equal to 1 euro per vital rhizome (Ceotto and Di Candilo, 2010). Furthermore, the fields used to produce rhizomes should be

very large because it has been estimated that from 1m² of mature culture (three years) we can harvest only about 20 vital rhizomes, obviously losing the plants from this area (Pilu et al, unpublished data). Hence a company or an institution that is planning to produce rhizomes to be transplanted, in the best conditions, should have at least three hectares of crop to produce the rhizomes that will be needed to transplant a 20 hectare field (see Figure 2) without losing this capacity every year (with a ratio between new hectares planted and hectares used to produce rhizomes of 6.6). Thus, considering that for maize F₁ seed production this ratio is more than 1 to 100, we can understand the difficulty and the costs of this activity on a large scale. Another strategy studied to tackle the propagation problem is the utilization of *in vitro* propagation technique as reported by Takahashi et al (2010). However, this technique is also very expensive and not compatible with a low input energy crop, where minimum hand-work and fossil fuels are required. Thus before *A. donax* can really become an economically viable energy crop, we have to solve this problem, perhaps by further experimentation. For example, it has been suggested by Ceotto and Di Candilo (2010) that cane cuttings might be propagated in water and moist soil. In fact canes contain nodes (mature canes have about one node every 15-20 cm) that are each able to generate a new plant in moist conditions (see Figure 1D). Considering that a three year old giant reed cane crop with an average height of 5 meters, has a potential production of about 40 canes m⁻², we may obtain a potential production of 107 new plants to be transplanted per hectare [(500 cm/cane) / (20 cm/node) x 40 (canes/m²) x 10,000 m²/hectare= 107 nodes/hectare], with a theoretical ratio between new hectares planted and hectares used to produce plants of 1,000 (transplanting 10,000 plants/ha) or 4,000 (transplanting 2,500 plants ha⁻¹) without losing the productive capacity of the site. Of course, in the first year the biomass production will be limited because only a few plants will be transplanted per hectare but starting from the second or third year, due to their vigorous growth, the plants will reach the full production. This approach appears to be the most promising way to adapt this culture on a large scale of cropping in the near future.

Conclusion

Considering that all the energy analysts foresee

Table 2 - Cost of the cultivation of *A. donax* in the 15 years life span of the field.

	Cost (Euros ha ⁻¹ year ⁻¹)	Cost of the field (Euros per 15 years)
Propagules	1,250†	1,250
Tillage and transplantation	700‡	700
Weeding and irrigation	550‡	550
Fertilization	170	2,550
Harvesting	360	5,400
total		10,500

†only in the first year (0.5 euro/propagule x 2,500 propagules/ha); ‡considering a 15 years duration of the crop

that the price of energy will rise further, we have to consider and study the cultivation and utilization of new plants in a near future where a “green industry” will become established and later replace the actual energy supply/industry based on fossil fuels. The cultivation of *A. donax* as energy crop in temperate climates could become a real opportunity to produce biomass at a low price compared to other crops such as maize or sorghum. The capacity to grow in poor soil and in general in marginal land could contribute to a better utilization of the territories, avoiding or minimizing the competition between fields used to produce food/feed and fields used to produce biomass. However, for an exact assessment of the utilization of this culture, we have to develop the agronomic procedures and the mechanization of several

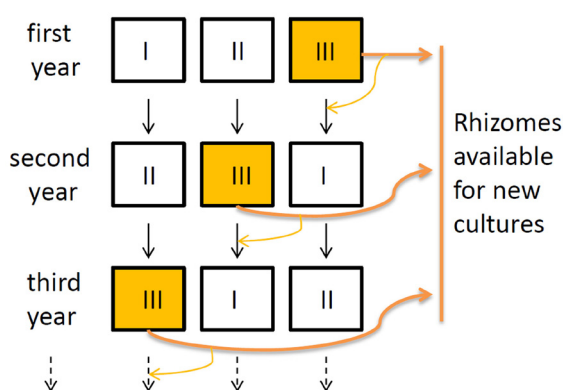

Figure 2 - Scheme of *A. donax* rhizomes production based on three fields/areas at different maturity/age. Square representing a field of 1 hectare, the Roman numeral inside the square indicating the age of the *A. donax* culture and the colored square representing the field/area where the rhizomes fragments are harvested and available to be “sown” in the new field (large arrows). Parts of the rhizomes harvested are used to replace the *A. donax* culture in the depleted field (thin arrows).

operations needed for its cultivation that are yet to be established. In particular further studies will be necessary to compare irrigated vs not-irrigated and fertilized vs not fertilized biomass production systems, in order to assess the real cost of cultivation and EROEI values in different environments and long-term field experiments.

Acknowledgements

The work from the Pilu laboratory was supported by grants from the Fondo Interno Ricerca Scientifica e Tecnologica. I wish to thank Dr F Cerino Badone and Dr D Reginelli for their hard work in the field and the Editor for his precious advices.

References

- Ahmad R, Liow P, Spencer D, Jasieniuk M, 2008. Molecular evidence for a single genetic clone of invasive *Arundo donax* in the United States. *Aquat Bot* 88: 113-120
- Angelini LG, Ceccarini L, Bonari E, 2005. Biomass yield and energy balance of giant reed (*Arundo donax* L) cropped in central Italy as related to different management practices. *Eur J Agron* 22: 375- 389
- Angelini LG, Ceccarini L, Nassi N, Bonari E, 2009. Comparison of *Arundo donax* L and *Miscanthus x giganteus* in a long-term field experiment in Central Italy: Analysis of productive characteristics and energy balance. *Biomass Bioenerg* 33: 635-643
- Barrière Y, Ralph J, Méchin V, Guillaumie S, Grabber JH, Argillier O, Chabbert B, Lapierre C, 2004. Genetic and molecular basis of grass cell wall biosynthesis and degradability. II. Lessons from brown-midrib mutants. *C R Biologies* 327: 847-860
- Ceotto E, Di Candilo M, 2010. Shoot cuttings propagation of giant reed (*Arundo donax* L) in water and moist soil: The path forward? *Biomass Bioenerg* 34: 1614-1623
- Clifton-Brown JC, Lewandowski I, 2002. Screening *Miscanthus* genotypes in field trials to optimise biomass yield and quality in Southern Germany. *Eur J Agron* 16: 97-110
- Cosentino SL, Copani V, D’Agosta GM, Sanzone E, Mantineo M, 2005. First results on evaluation of *Arundo donax* L clones collected in Southern Italy. *Ind Crop Prod* 23(2): 212-22
- Directive 2009/28/EC, 2009. Directive of the European Parliament and of the Council of 23 April 2009 on the promotion of the use of energy from renewable sources and amending and subsequently repealing Directives 2001/77/EC and 2003/30/EC
- Dudley TL, 2000. *Arundo donax* L, “Invasive Plants of California’s Wildlands”, pp. 53-58. Brossard

- CC, Randall JM, Hoshovsky MC eds. University of California Press, Berkeley, California
- Ge X, Burner DM, Xu J, Phillips GC, Sivakumar G, 2011. Bioethanol production from dedicated energy crops and residues in Arkansas, USA. *Bio-technol. J.* 6: 66–73
- IEA Report, 2009. International Energy Agency
- IEO Report, 2006. International Energy Outlook
- Jeon YJ, Xun Z, Rogers PL, 2010. Comparative evaluations of cellulosic raw materials for second generation bioethanol production. *Lett Appl Microbiol* 51: 518-524
- Lowe S, Brown M, Boudjelas S, De Poorter M, 2000. '100 of the World's worst invasive alien species: a selection from the global invasive species database'. (The Invasive Species Specialist Group of the World Conservation Union)
- Maehara T, Takai T, Ishihara H, Yoshida M, Fukuda K, Gau M, Kaneko S, 2011. Effect of lime pretreatment of brown midrib sorghum. *Biosci Biotechnol Biochem* 75: 2415-2417
- Mariani C, Cabrini R, Danin A, Piffanelli P, Fricano A, Gomasca S, Dicandilo M, Grassi, F, and Soave C, 2010. Origin, diffusion and reproduction of the giant reed (*Arundo donax* L): a promising weedy energy crop. *Ann Appl Biol* 57: 191-202
- McKendry P, 2002. Energy production from biomass (part 1): overview of biomass. *Bioresour Technol* 83: 37-46
- Méchin V, Argillier O, Menanteau V, Barrière Y, Mila I, Pollet B, Lapierre C, 2000. Relationship of cell wall composition to in vitro cell wall digestibility of maize inbred line stems. *J Sci Food Agric* 80: 574-580
- Perdue RE, 1958. *Arundo donax* - source of musical reeds and industrial cellulose. *Econ Bot* 12: 368-404
- Pilu R, Bucci A, Cerino Badone F, Landoni M, 2012. Giant Reed (*Arundo donax* L): a weed plant or a promising energy crop? *Afr J Biotechnol* 11: 9163-9174
- Rossa B, Tuffers AV, Naidoo G, von Willert DJ, 1998. *Arundo donax* L (Poaceae) -a C3 species with unusually high photosynthetic capacity. *Botanica Acta* 111: 216-221
- Saballos A, Vermerris W, Rivera L, Ejeta G. 2008. Allelic association, chemical characterization and saccharification properties of brown midrib mutants of sorghum (*Sorghum bicolor* (L) Moench). *Bioenerg Res* 1: 193-204
- Sattler SE, DL Funnell-Harris, JF Pedersen, 2010. Brown midrib mutations and their importance to the utilization of maize, sorghum, and pearl millet lignocellulosic tissues. *Plant Science* 178: 229-238
- Schievano A, D'Imporzano G, Corno L, Adani F, Cerino Badone F, Pilu R, 2012. Più biogas a costi inferiori con arundo o doppia coltura. Articolo pubblicato sul supplemento a l'Informatore Agrario 25: 21-25
- Scordia D, Cosentino S, Lee J W, Jeffries TW, 2012. Bioconversion of giant reed (*Arundo donax* L) hemicellulose hydrolysate to ethanol by *Scheffersomyces stipitis* CBS6054. *Biomass Bioenerg* 39: 296-305
- Seca AML, Cavaleiro JAS, Domingues FMJ, Silvestre AJD, Evtuguin D, Neto CP, 2000. Structural Characterization of the Lignin from the Nodes and Internodes of *Arundo donax* Reed. *J Agric Food Chem* 48:817-824
- Takahashi W, Takamizo T, Kobayashi M, Ebina M, 2010. Plant regeneration from calli in Giant Reed (*Arundo donax* L). *Grassland Sci* 4: 56224-56229
- Wu L, Mitsuhiro A, Masakazu I, Masahisa W, Takai T, Gau M, Tokuyasu K, 2011. Low temperature alkali pretreatment for improving enzymatic digestibility of sweet sorghum bagasse for ethanol production. *Bioresour Technol* 102: 4793-4799