

University at Albany, State University of New York Scholars Archive

Biological Sciences

Honors College

Spring 5-2019

RNA Secondary Structure of 3'UTR Regulates Translation Control

M. Grace Hren

University at Albany, State University of New York

Follow this and additional works at: https://scholarsarchive.library.albany.edu/honorscollege_biology

 Part of the [Biology Commons](#)

Recommended Citation

Hren, M. Grace, "RNA Secondary Structure of 3'UTR Regulates Translation Control" (2019). *Biological Sciences*. 62.
https://scholarsarchive.library.albany.edu/honorscollege_biology/62

This Honors Thesis is brought to you for free and open access by the Honors College at Scholars Archive. It has been accepted for inclusion in Biological Sciences by an authorized administrator of Scholars Archive. For more information, please contact scholarsarchive@albany.edu.

RNA Secondary Structure of 3'UTR Regulates Translation Control

An honors thesis presented to the
Department of Biological Sciences,
University at Albany, State University of New York
in partial fulfillment of the requirements
for graduation with Honors in Biology
and
graduation from The Honors College

M. Grace Hren

Research Mentor: Katarina Tlučková, Ph.D.
Research Advisor: Prashanth Rangan, Ph.D.

December 2018

Abstract

According to the central dogma of biology, DNA is transcribed into mRNA. This mRNA is then translated into a protein. Translation of mRNA into protein is extremely precise, and as such is controlled by many different factors, both spatially and temporally. This phenomenon is known as translation control. Many times, this regulation is influenced by secondary structures, often in the form of stem loops on the mRNA. These secondary structures found on mRNA, specifically in the 3'Untranslated Region (3'UTR) of mRNA, can influence cellular gene expression. These genes can be upregulated or down regulated, depending on stem loop function. When trans-acting regulatory factors, such as RNA binding proteins (RBPs) bind to the 3'UTR mRNA, repression or activation of the gene can be initiated; translation can also be controlled by cis-acting factors. Our research focused on determining whether the 3'UTR secondary structures played a role in translation control. To study the function of these secondary structures, we deleted stem loops on 3'UTR mRNA in a specific gene, known as polar granule component (*pgc*), using *Drosophila melanogaster* as a model organism. The phenotypes of several deleted stem loop mutants were observed via antibody staining. Using western blot and qRT-PCR experiments, the level of expression of the *pgc* protein and *pgc* mRNA was quantified, to determine if this deletion had an effect in translation control in both embryogenesis and oogenesis, two developmental cycles in *D. melanogaster*.

Acknowledgements

I would like to thank my Research Advisor, Dr. Prashanth Rangan, for allowing me to work in the Rangan Lab for the past two years. I have learned more about biology in these few years than I could have ever imagined. I would also like to thank my Research Mentor, Katarina Tlučková, for her support throughout my time in the Rangan Lab. Additionally, I would like to thank all the members of the Rangan Lab, for all the assistance they have given me. Specifically, I would like to thank Pooja Flora for helping me prepare my presentation for the Undergraduate Research Symposium. Without the help I received from all members of the lab, whether it was an answer to an in-depth research question or a demonstration on how to proceed with a specific portion of my research, the support they have given me is invaluable. I will remember my time in the Rangan Lab quite fondly. Finally, I would like to thank my family for always supporting my educational endeavors.

List of Figures

Figure 1	5
Figure 2	6
Figure 3	14
Figure 4	14
Figure 5	15
Figure 6	16
Figure 7	16
Figure 8	17
Figure 9	17
Figure 10	18
Figure 11	18
Figure 12	19
Figure 13	19
Figure 14	20
Figure 15	20
Figure 16	21
Figure 17	21
Figure 18	22
Figure 19	22
Figure 20	23
Figure 21	23
Figure 22	24
Figure 23	24
Figure 24	25
Figure 25	25
Figure 26	26
Figure 27	27

Table of Contents

Abstract	ii
Acknowledgements	iii
List of Figures	iv
Introduction	2
Materials and Methods	7
Apple Juice Plate Production	7
Embryo Collection	8
Ovary Dissection.....	8
Immunohistochemistry	9
Western Blot	11
qRT-PCR.....	13
Results	14
Stem Loop 6 Analysis: Oogenesis	14
Stem Loop 1 Analysis: Embryogenesis and Oogenesis.....	18
Stem Loop 10 Analysis: Embryogenesis and Oogenesis.....	23
Protein YT521B Depletion	24
EMSA Staining	27
Discussion	28
Deletion of stem loop 6 is not significant during oogenesis.....	29
Deletion of stem loop 6 is not significant during embryogenesis.....	30
Deletion of stem loop 1 causes 3-fold upregulation of pgc gene in oogenesis.....	30
Deletion of stem loop 1 causes 3-fold upregulation of pgc gene in embryogenesis.....	31
Deletion of stem loop 10 causes 5-fold upregulation of pgc gene in embryogenesis.....	32
Depletion of protein YT521B causes no change in regulation in oogenesis	33
Depletion of protein YT521B causes significant upregulation in embryogenesis	34
Protein YT521B and stem loop 10 interact in embryogenesis	34
Conclusions & Future Directions.....	35
References	36

Introduction

The central dogma of biology states that DNA is transcribed to messenger RNA (mRNA), and this mRNA is translated into a sequence of amino acids to form a protein. More precisely, translation is the process by which the genetic code carried in the mRNA is decoded to produce a specific sequence of amino acids that will eventually form a protein. Translation has been shown to be controlled at multiple layers, both spatially and temporally. Translational regulation has also been shown to be capable of altering genetic expression. Both cis acting elements and trans acting factors can act upon a gene and affect translational regulation. A cis acting element is one that is found directly on the transcript, and a trans acting factor is one that acts on the transcript (Gebauer, Preiss, & Hentze, 2012). A gene is made up of several important components, including a 5' Untranslated Region (UTR), promoter, coding sequence (cds), 3'UTR, and a polyA tail. The nucleotides found in the coding sequence are the part of the gene that will be directly transcribed to mRNA, and then translated to form a protein. However, the other components of the gene, specifically the 3'UTR has been shown to play a role in translational control. In the 3'UTR, certain cis acting elements are found. Trans acting factors can recognize the cis acting elements in the 3'UTR. This recognition has been shown to have a critical role in translation control. It has been shown that the 3'UTR mRNA is sufficient and critical in the regulation of translation (Rangan et. al, 2009).

Trans acting factors, such as RNA binding proteins, can act upon this 3'UTR. It has been previously shown that trans acting factors are able to recognize specific mRNA sequences, to bind to the mRNA and control translation. Trans acting factors include RNA binding proteins, as previously mentioned, miRNAs, or RNA-RNA interactions (Kramer & Carrington, 2011).

The question posed is whether the secondary structure in the 3'UTR is an important factor in this protein binding. In previous research, completed by Katarina Tlučková, a bioinformatics approach was used to probe for the structure of the 3'UTR. It was determined that the 3'UTR forms secondary structures with multiple stem loops. These stem loops were also determined to be implicated in RNA protein binding. In this research, the specific secondary stem loops structures found on the 3'UTR were focused on. These structures have been aptly named "stem loops," due to their loop-like structure on the mRNA. It was hypothesized that these stem loop structures influence the translational of mRNA into a protein.

The model organism, *Drosophila melanogaster*, more commonly known as the fruit fly, was used to understand the regulation of translation. *D. melanogaster* was a good model organism to use, as studies on this organism can be conducted very quickly, due to their short life cycle that lasts only several weeks (Jennings, 2011). Additionally, the developmental processes of *D. melanogaster* can be widely applied to many other organisms, as these processes are conserved. Two processes, embryogenesis and oogenesis, were investigated to address translational control. In the early development of the embryo, there are cells known as the primordial germ cells. These cells are the first to specify and first to form in *D. melanogaster*. Primordial germ cells give rise to the germ line stem cells. These cells will eventually give rise to the haploid gametes, or the sperm and the egg. Germ line stem cells can also replenish themselves (Dansereau & Lasko, 2009). For primordial germ cells to give rise to the germ line stem cells, a specialized area of the embryo known as the germ plasm is required. All organisms contain some version of this germ plasm. In the germ plasm, there is no transcriptional input; only translation occurs in this area. In *D. melanogaster*, when germ line stem cells divide, one daughter cell becomes a sperm or an egg (depending on the sex of the organism) and the other

daughter cell becomes another germ cell, which can continually repeat this process. Due to this, the germ line stem cells are often referred to as “immortal cells.” Germ cells contrast somatic cells, or body cells, in which both daughter cells become somatic cells that will eventually die (Lehmann, 2016).

The primordial germ line cells are stem cells that provide a constant supply of gametes to the *D. melanogaster*. In a female fly, oogenesis begins with the formation of a 16-cell cyst made of interconnected germ cells. During oogenesis, maternal RNA is produced by the mother and deposited into the developing embryo. This RNA is crucial for the development of the embryo. Many different RNAs are included in this deposited maternal RNA. The localization and expression of these RNAs is controlled both spatially and temporally. One of these RNAs is known as polar granule component, or *pgc* (Nakamura et al., 1996).

Pgc was used as the studied gene of interest, as translation of this maternally deposited RNA is highly regulated. During embryogenesis, certain maternally deposited RNAs begin to localize at the pole cells of the embryo, or the germ plasm. These localized pole cells are the cells that will eventually form the germ cells of the next generation of *D. melanogaster*. This deposited mRNA is required for development of the germ cells, as germ cells are formed by translation of proteins from maternal mRNAs. No transcription occurs in the germ plasm. *Pgc* is an important maternal RNA, as this gene is a global transcription silencer. Meaning, that in cells in which *pgc* is translated, there is no transcription of other genes. This transcriptional silencing ensures that the germ line in *D. melanogaster* is properly maintained and differentiation of these germ cells to somatic cells does not occur (Flora et al., 2018). In the early stages of development, the oocyte is made of undifferentiated stem cells which can differentiate into any type of specialized cell. In the embryo, *pgc* is expressed only in the pole cells, as these are the

cells that will make up the next generation. In *pgc* mutants, the germ cells can transcribe somatic genes, which will cause the germ cells to exit their undifferentiated state, and the germ plasm will be lost, causing sterility.

Pgc RNA is expressed constitutively throughout oogenesis and embryogenesis. In later stages of embryogenesis, *pgc* RNA has localized to the pole cells. However, *pgc* protein is expressed during two specific time points; once during oogenesis and once during embryogenesis. Experiments can be conducted at these developmental time points of oogenesis and embryogenesis, to determine the effects of *pgc* 3'UTR mRNA secondary structure. This makes *pgc* a choice gene to study for our experiments, as its translation from mRNA to protein is highly controlled and regulated, as indicated by its expression during two specific time points.

The 3'UTR portion of *pgc* mRNA was the area of interest in these experiments. Since the 3'UTR has been implicated to be both required and sufficient in translation control, and *pgc* mRNA is required for proper propagation of the germ line stem cells, this pathway can be used to help understand the necessity of the stem loops found on the *pgc* 3'UTR mRNA. It was hypothesized that RNA binding proteins interact with these stem loops on the *pgc* 3'UTR mRNA and allow the regulation of the germ line stem cells to occur.

In our experiments, transgenic flies were prepared with a reporter gene. The *pgc* 3'UTR mRNA was fused with green fluorescent protein, or GFP. This allowed the expression of *pgc* protein to be tracked with the expression of this fluorophore. Each fruit fly embryo was injected with nos 5'UTR-HA-GFP- Δ SL *pgc* 3'UTR. Δ SL (deleted stem loop) represents the portion of the gene that will contain a deleted stem loop. Nanos (*nos*) was used as a promoter to ensure that this *pgc* transcript was always translated. Specific stem loops found on the *pgc* 3'UTR mRNA were deleted, to determine whether these stem loops played a role in translation control during

both oogenesis and embryogenesis. Using ovaries and embryos collected from *D. melanogaster* with certain stem loop structures deleted, the implication of these stem loops could be determined. On *pgc* 3'UTR mRNA, there are ten different stem loop structures. My research focused on a specific number of these stem loops. Below is a picture of all ten of the stem loops that were determined to be found in the *pgc* 3'UTR mRNA. Depending on the changes in protein and mRNA expression that were detected after deletion of a stem loop from the *pgc* 3'UTR mRNA, then it could be concluded that this stem loop is required for translation control.

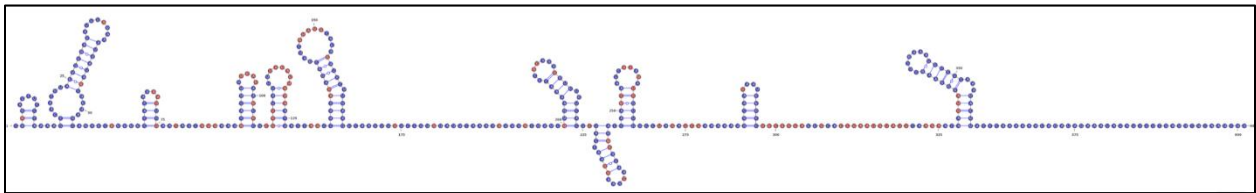

Figure 1: This figure shows a picture of the *pgc* 3'UTR mRNA, and the stem loops found on this structure, as determined by probing methods, combined with a bioinformatics approach. This research was conducted by my colleagues.

One of the stem loops, stem loop 10, has been implicated to have a potential binding site for a known RNA binding protein. This protein is a YTH protein, with a YTH domain. This protein domain is highly conserved and has been previously shown to remove transcripts of meiosis-specific genes that are expressed in mitotic cells. In yeast, the YTH domain recognizes the specific sequence, shown in the figure below (Zhang et. al, 2010). A similar sequence is found on stem loop 10. This protein is hypothesized to recognize and bind to stem loop 10. After binding, it will recruit other complexes to perform their role. If this protein is not bound to the stem loop, this process is much slower. *Drosophila* have two known YTH proteins, CG6422 and YT521B (Lence et al., 2016). In our experiments, protein YT521B was focused on. Three different flies with YT521B mutants were analyzed. CRISPR-Cas mutant flies from an outside

lab were acquired, labeled NP1, NP2, and NP3. All three of these flies had a frameshift mutation, making them incapable of producing the YT521B protein. The YT521B mutant flies were crossed with our flies from the lab that carry the pgc transgene, to see how the pgc gene is affected when this protein cannot be normally produced by the fly.

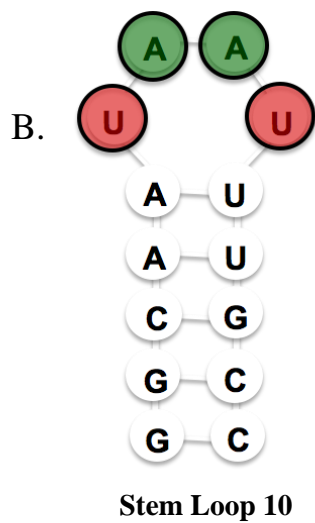

Figure 2A: Shows the conserved sequence domain that is recognized by the YTH protein.

Figure 2B: Displays the sequence found on stem loop 10, that was hypothesized to recognize and allow binding with the YTH protein, YT521B.

Materials and Methods

Apple Juice Plate Production

Two separate solutions were prepared to create apple juice plates. Solution A contained 22.5 grams of bacto-agar and 0.75 L of dH₂O. This solution was autoclaved with a stir bar for a 20 and 10 minute cycle. Solution B contained 250 mL of apple juice and 25 grams of dextrose. This solution was heated and stirred until both components were completely mixed. After Solution A has been autoclaved and Solution B has been mixed, they were added together while

mixing. Next, 10 mL of 10% tegosept in ethanol was added to this mixing solution. After thoroughly mixed (should take about 5-10 minutes), this solution can be poured into petri dishes. After these petri dishes containing the apple juice solution cooled they were stored in 4°C, for long-term storage.

Embryo Collection

As many flies as possible were fattened in bottles supplemented with lyophilized yeast overnight at 25°C or 29°C. Flies that were four days old were optimal, with a 3:1 ratio of females to males. Next, a yeast paste was prepared. The yeast should have enough deionized water added to it so that it was a consistency equivalent to toothpaste. This yeast could be stored at 4°C until it is used. The end of serological pipette was used to put a dollop of yeast paste on an apple juice plate and was spread. The flies to be analyzed were placed in a fly cage with an apple juice plate with yeast on the bottom of the cage. This cage was stored in 25°C for 2 hours. The apple juice plates were then removed from the cages. 50% bleach and 50% deionized water was poured over the apple juice plates and incubated at room temperature for five minutes. The bleach solution was then poured into small tube with a mesh net at the bottom, allowing the embryos to be caught. Water was used to rinse the plates, until all the embryos had been removed from the apple juice plates and transferred into the mesh net.

Ovary Dissection

Flies were first sorted to separate male and female flies. Female flies for dissection were placed in bottles with yeast in 25°C overnight to fatten. The next day, flies were anesthetized using carbon dioxide. The flies were placed into a crystallizing dish in a PBS solution. Fine needle tweezers were used to separate each egg chamber from one another, while the entire

ovary was held at the base with the tweezers. Visualization of the ovaries for dissection was obtained by using microscope. The ovaries from about 20-30 per fly line were collected and placed into a 1.5 mL Eppendorf tube in PBS solution. Siliconized tubes were used to prevent the ovaries from sticking to the sides of the tube. These ovaries were frozen at -80°C until needed for further use.

Immunohistochemistry (Embryos)

Once embryos were collected onto the mesh net, this net was transferred into a glass scintillation vial that contained 1 mL of 1xPBS, 1 mL of 37% formaldehyde, and 8 mL of heptane. The net was swirled around so the embryos were fully removed from the net and transferred into the solution. This vial was shaken on the shaker gently for 40 minutes at 125 rpm. Next, the lower formaldehyde phase was removed from solution with a Pasteur Pipette. It was important to ensure that all formaldehyde was completely removed, as it was key to getting a good yield of embryos falling down in the methanol step. Next, the vial was tilted to the side to ensure that all the formaldehyde was removed from the solution. Then, 8-10 mL of methanol was added to the vial. This solution was then shaken vigorously on the shaker for two minutes. The embryos that had fallen to the bottom of the vial were transferred to a 1.5 mL Eppendorf tube. The embryos were then washed in 0.5 mL of methanol 2-3 times over a 10 minute period. The embryos can then be stored in methanol at -20°C in 1 mL of methanol, until needed. When the embryos were needed, they were rehydrated in PBST (PBS/ 0.2% tween) for 3-5 minutes at each step on the shaker. In the first step, a 7:3 ratio methanol to PBST was used to rehydrate. In the second step, a 1:1 ratio of methanol to PBST was used to rehydrate. In the final step, a 3:7 ratio of methanol to PBST was used to rehydrate. The embryos were then blocked in BBT (50 mL of 1xPBST and 500 mg of BSA) in 30 minute time periods, four times. The embryos were

incubated overnight while in 4°C while rocking in BBT/1°Abs. The next day, the solution was aspirated and the following washes were performed. 1 mL BBT/2% serum was used to wash the embryos for 1x10 minutes, 1x20 minutes, and 2x30 minutes. The embryos were the incubated at room temperature while rocking in BBT/2% serum/2°Abs. Next, the embryos were washed with 1xPBST for 1x10 minutes and 5x20 minutes. Then, 1 drop of VectaShield solution was added. The embryos were then added to a slide, a coverslip was added, and the coverslip was sealed with nail polish. These slides can be stored at 4°C, until one was ready to image the embryos.

Immunohistochemistry (Ovaries)

Collected ovaries were taken from -80°C and were fixed at room temperature for 30 minutes in 500 µL of Formaldehyde (methanol free). If the ovaries were to be stored after this step, they were washed with 1 mL of 1xPBS three times for five minutes at room temperature and stored at 4°C. Next, the PBS was removed and 1 mL of permeabilizing solution (made of PBST and 1% Triton-X-100) and rotated at room temperature for one hour. Then, the PBST and Triton-X-100 solution was removed and replaced with BBT (PBST + 1% BSA). The ovaries were blocked in BBT for more than two hours at room temperature, while rotating. They could also have been blocked at 4°C. Next, the BBT was removed, and replaced with primary antibody diluted in 0.5 to 1 mL of BBT. This was incubated overnight at 4°C while rotating. Then, the primary antibody was removed, and the ovaries were washed at room temperature while rotating with several different washes. The first was for 10 minutes with BBT. The second was for 20 minutes with BBT. The third was for 30 minutes with BBT. And the final wash was for 30 minutes with BBT/2% normal donkey serum. One mL of each solution was used in these washes. Then, the secondary antibody was added to the solution. The serum used was from the source in which the secondary antibody was generated. The BBT/serum wash was removed, and

the secondary antibody (which contained a fluorescent marker) was added. This was incubated at room temperature while rotating, or overnight at 4°C. Next, the ovaries were washed in PBST 5 times, each wash lasting 10 minutes. After, the ovaries were resuspended in 100 µL of mounting solution. The mounting solution was made of 50% glycerol and 0.2% DABCO. The ovaries sat in this solution for 30 minutes to 1 hour. Finally, this solution was mounted on a slide and a coverslip was added. The slip can be sealed with nail polish, after excess liquid was absorbed.

Western Blot

Protein from embryos or ovaries was first prepared. The ovaries and embryos were collected via the previously mentioned two methods. The ovaries or embryos were homogenized at 4°C in 50 µL of lysate solution. Next, this lysated material was spun down at 4°C at full speed in the centrifuge for fifteen minutes. Once done centrifuging, there was a top layer, middle layer, and a pellet. The middle layer, containing the protein, was carefully removed and put into a new, clean, labeled 1.5 mL centrifuge tube. A Bradford Assay was conducted, to determine the concentration of protein in each sample. The Bradford Assay allowed the creation of a curve of absorption vs. known concentration, and the absorption of our samples were compared to this curve in order to determine the exact concentration of each sample.

In test tubes, protein extract, water, and a mixture of Loading Dye: BME in a 9:1 ratio was mixed together. 3.75 µL of LD:BME mixture was added to each test tube. A total of 15 µL of solution was present in each test tube. These samples were spun down, and incubated at 95°C for five minutes. Next, the gel was set up for the western blot. 1X sodium dodecyl sulfate (SDS), an anionic detergent, was added to the apparatus, as this was the solution in which the gel was run. 5 µL of ladder was loaded into the first gel well, and 15 µL of each sample was

subsequently added after the ladder. The gel was run at 100 V for 1 hour. After the gel had finished running, it was transferred, in transfer buffer, onto a thin nitrocellulose membrane. The transfer sandwich was assembled in the following order: sponge, two transfer papers, gel, nitrocellulose membrane, two transfer papers, and sponge. It was ensured that the gel was closest to the negative side of the apparatus, and the membrane was closest to the positive side of the apparatus. The transfer apparatus was then surrounded by ice, a stir bar was added, and the transfer was allowed to run at 100 V for one hour.

After the transfer was complete, the membrane must be blocked with 5% milk (10 grams of powdered milk and 200 mL of PBST) for two hours at room temperature. Next, the membrane was washed with primary antibody diluted with 5% milk (3.3 μ L of Rat HA antibody with 10 mL of 5% milk) for one hour at room temperature, or overnight at 4°C. The membrane was then rinsed with 0.5% milk at room temperature, and the secondary antibody was prepared. The membrane was washed with the secondary antibody diluted with 5% milk (2 μ L of Rat HRP and 10 mL of 5% milk) for one hour at room temperature. The membrane was washed with PBST at room temperature and imaged.

The membrane was blocked for two hours with 5% milk once again at room temperature, and a second antibody staining was completed. After blocking, the membrane was washed with a primary antibody solution diluted with 5% milk (2 μ L of Rb Vasa and 10 mL of 5% milk) for one hour at room temperature. The solution was washed with 0.5% milk at room temperature, and then the membrane was washed with the secondary antibody diluted with 5% milk (2 μ L of Rb HRP and 10 mL of 5% milk) for one hour at room temperature. Finally, the membrane was washed with PBST at room temperature, and imaged for a final time.

qRT-PCR

The previously collected embryos or ovaries were taken and 100 μL of Trizol reagent was added. This solution was then homogenized with a pestle. 900 μL of Trizol was added for a total volume of 1 mL. The homogenized tissue was incubated at room temperature for five minutes. Then 200 μL of chloroform was added to the solution, and the tubes were covered tightly and shaken for 15 seconds. The samples were then incubated at room temperature for 5 minutes. After incubation, the solution was centrifuged at 13,000 x g for 20 minutes at 2 to 8°C. 450 μL of the colorless aqueous phase, containing RNA, was removed and added to a fresh 1.5 mL Eppendorf tube. 45 μL of sodium acetate (10%), 900 μL of 100% ethanol, and 1 μL of glycol blue was added to the tube and was mixed. The sample was incubated at room temperature for 5-10 minutes. The sample was moved to -20°C or -80°C for 1-2 hours. The sample was centrifuged at 13,000 x g for 20 minutes at 4°C. The RNA precipitate formed a pellet on the side and bottom of the tube. The RNA pellet was washed with 500 μL of 75% ethanol, while vortexed. The sample was centrifuged at 13,000 x g for 5 minutes at 4°C. The RNA pellet was dried at room temperature for 20 minutes by air-drying. All ethanol was removed with a P20 before air drying. After 10 minutes, excess ethanol was removed again. 25 μL of water was added to the RNA pellet. A micropipette was used to facilitate dissolution of the pellet at 50°C for 10 minutes. The RNA sample was then Nano-dropped. A 10 μg aliquot of nucleic acid was added to a 1.5 mL microcentrifuge tube. The volume was brought up to 17 μL with RNase free water. 2 μL of 10X TURBO Dnase buffer was added to the solution. Then, 1 μL (2 U) of TURBO Dnase was added to the solution. The solution was incubated at 37°C for 30 minutes. The 10X Dnase Inactivation Reagent was vortex and 2 μL of this solution was added to the reaction. The reaction was incubated at room temperature for 5 minutes, while

occasionally flicking the tube. The solution was spun down at 10,000 x g for 1.5 minutes. After centrifugation, the supernatant was transferred to a fresh tube. Nano-drop was again performed, using the RNA sample and 1 ug of RNA in a First-Strand cDNA Synthesis Reaction.

In a PCR tube mix together 1 μ L of oligo(dT), 1 μ L of dNTP mix, X μ L RNA (1-5 ug total RNA), and 10 μ L nuclease-free water. This sample was incubated at 65°C for 5 minutes, then incubated on ice for at least 1 minute, and was spun briefly. Then 4 μ L of 5x First-Strand Buffer, 1 μ L DTT (0.1 M), 1 μ L RnaseOUT (40 U/ μ L), 1 μ L SuperScript III RT (200 U) or 1 μ L of nuclease-free water (for -RT control). This solution was mixed by pipetting gently, then incubated at 50°C for 1 hour. Then the sample was incubated at 70°C for 15 minutes and placed on ice. This could be stored at -20°C, until needed for further use. In a PCR tube, 19,875 μ L of nuclease-free water, 2.5 μ L of Taq DNA Polymerase PCR Buffer (10x), 0.5 μ L of 10 mM dNTP mix, 1 μ L cDNA (template), 0.5 μ L of 10 μ M forward primer, 0.5 μ L of 10 μ M reverse primer, 0.125 μ L Taq DNA polymerase were added and mixed. This mix was made for the control, and experimental + and - RT reactions. The PCR tubes were put in the PCR machine and the thermocycling conditions were set.

Results

Stem Loop 6 Analysis: Oogenesis

The first process analyzed was oogenesis in flies that had stem loop 6 deleted. In our western blot of Drosophila ovaries, we first stained the blot with HA antibody. This antibody showed the expression of GFP. As the genome of the 3'UTR pgc has GFP injected into our fly lines, staining for GFP also stains for protein translated by pgc. The quantification of the GFP

shown by the HA antibody, can allow quantification of pgc protein. The western blot is below, along with the graph analyzing the level of protein for each fly line.

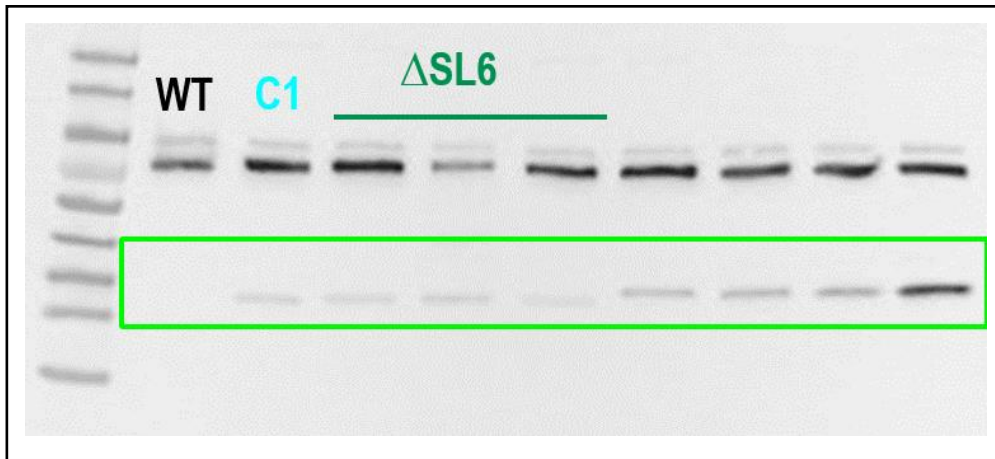

Figure 3: This image displays the expression of GFP (or pgc), and the expression of Vasa in the ovaries of the WT, 36c1, and dSL6 flies.

Vasa antibody was used to stain for Vasa protein, a normally occurring protein in our fly lines. Vasa staining is used as a control for the western blot and is also used to quantify the blot. The graph below shows the quantification of the western blot of dSL6.

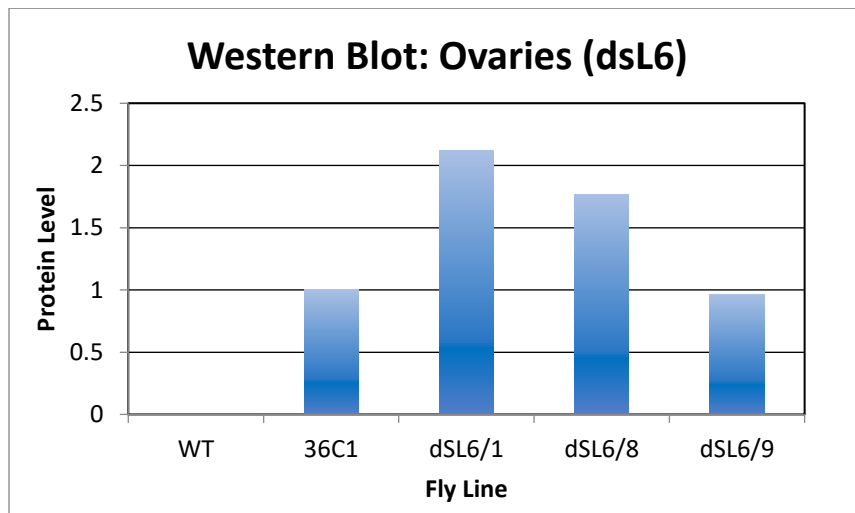

Figure 4: The quantification of the expressed protein level in fly line with stem loop 6 deleted, when normalized to Vasa. There is no significant difference in protein level between the control (36c1) and the flies with stem loop 6 deleted.

Next, the level of EGFP mRNA expression was determined in the ovaries of the flies with stem loop 6 deleted, through a qRT-PCR experiment. dsL6/8 was focused on specifically, and the level of mRNA in dsL6/8 was compared to the level of mRNA in the control. As shown in the graph below, the when standard error was considered, there was no significant difference between the level of mRNA expressed in the control and flies with stem loop 6 deleted.

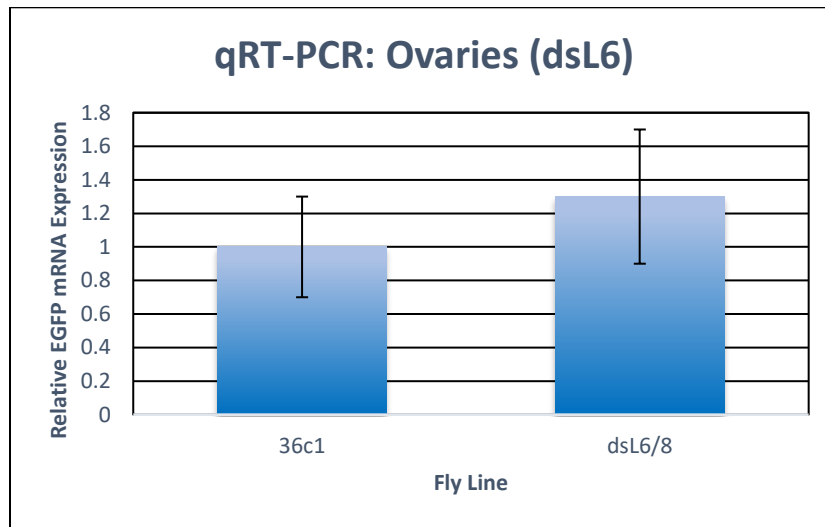

Figure 5: qRT-PCR analysis of 36c1 and dsL6/8. There is no significant difference between mRNA level in the control and in flies with stem loop 6 deleted.

Finally, the level of protein translated in dsL6 must be normalized to the level of mRNA. Both the sample and the control must be normalized in order to determine the actual expression of the gene. As all dsL6 samples are the same, just injected into the plasmid in different ways, these differences must be normalized, to account for human error, in order to determine the actual expression of the gene. These stem loop deletions must be normalized and can then be compared to the control, to determine whether an upregulation, downregulation, or no change in gene expression occurred. Below is the normalization of dsL6, compared to the control, 36c1.

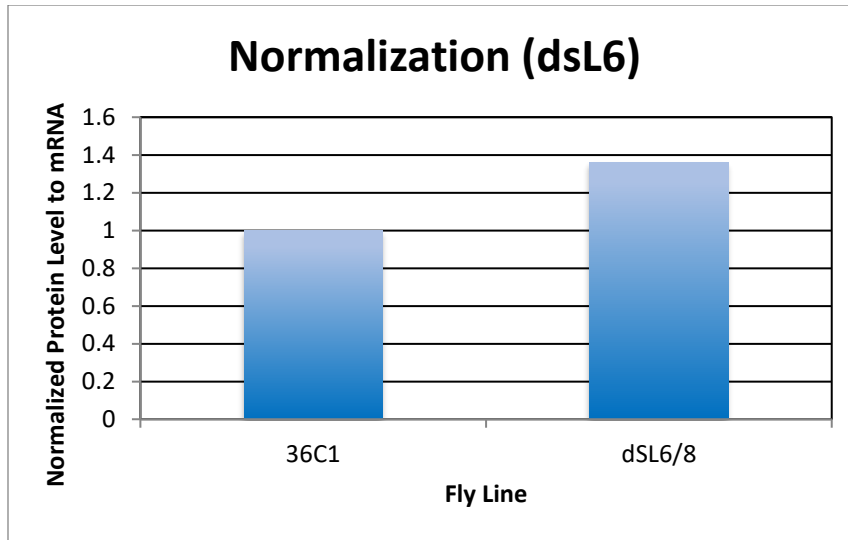

Figure 6: This figure shows the normalization of the level of protein dsL6 to the level of mRNA. The control is incorporated for comparison. No significant difference was observed between the control and flies with stem loop 6 deleted.

Next, an antibody staining of both the embryos and ovaries of dsL6 were analyzed. This allowed us to determine if there was a phenotype visible in embryogenesis or oogenesis in this mutant fly line. A confocal microscope was used to image the embryos and the ovaries. The images on the right show the embryos and the images on the left show the ovaries.

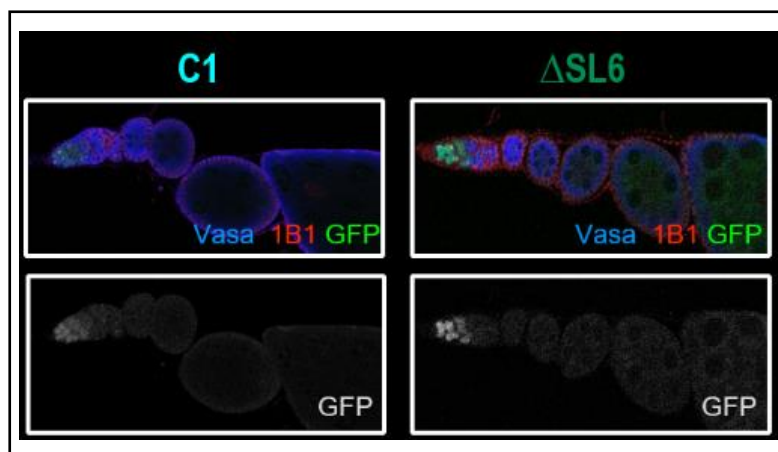

Figure 7: The above image compares the Vasa and GFP channels of the ovaries of dsL6 flies to the ovaries of control flies, as captured through confocal microscopy.

Stem Loop 1 Analysis: Oogenesis

A western blot was analyzed for protein level of pgc in oogenesis in flies with stem loop 1 deleted. Each western blot was completed in triplicate, in order to standardize the results. HA and Vasa antibodies were used to stain, again using HA to show pgc protein and Vasa for normalization. The results of this western blot are shown below.

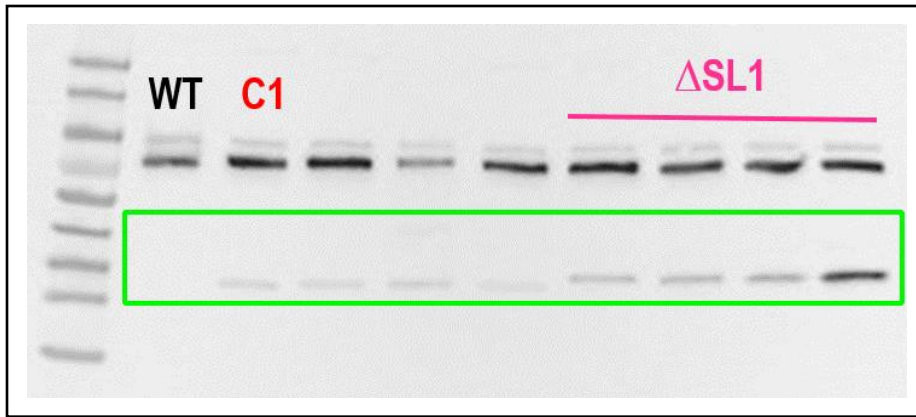

Figure 8: This image shows the western blot of dSL1 flies. The protein level of pgc, as determined through staining for GFP, is shown in the green box. The protein level of Vasa, for normalization is shown above.

Just as was performed in the analysis of stem loop 6, a quantification of the western blot was performed. This quantification is shown below.

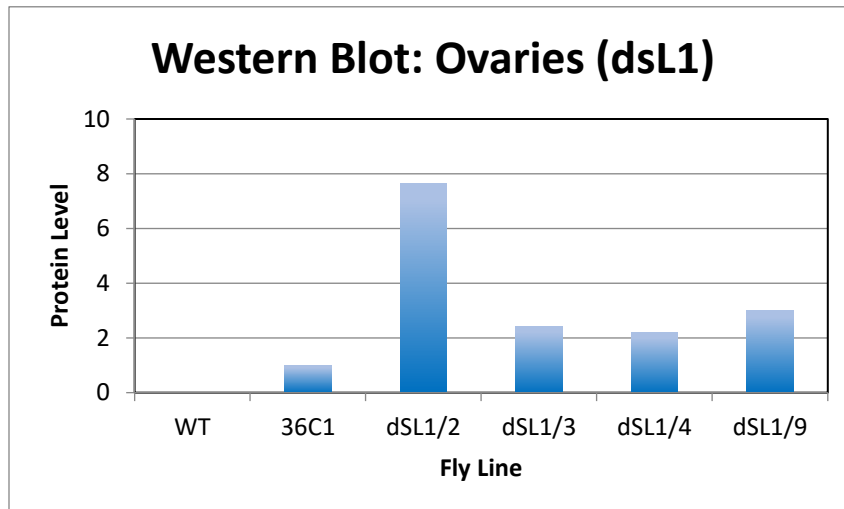

Figure 9: Shows the quantification of the western blot, after the GFP protein level was normalized to the Vasa protein level. dSL1 is compared to the control (36c1).

After completing the western blot and quantification, a qRT-PCR experiment was performed to determine the level of mRNA in flies with stem loop 1 deleted. The graph below shows the results from the quantification of this experiment.

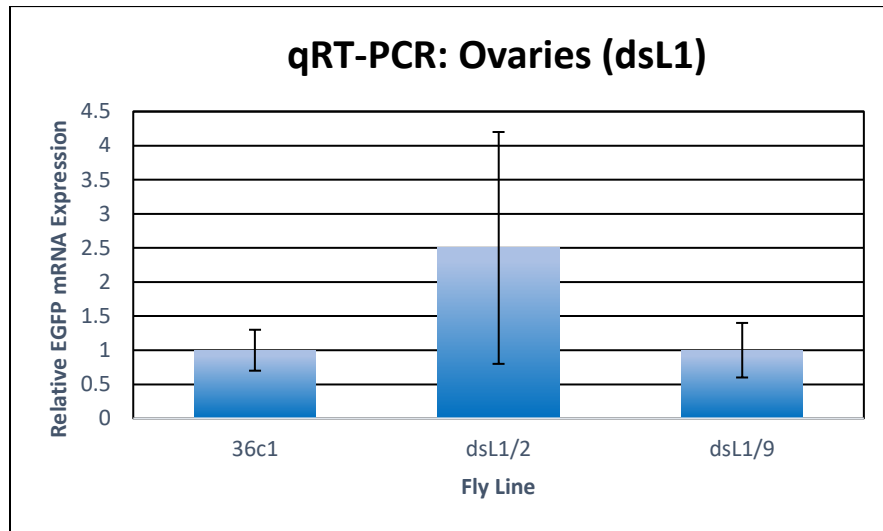

Figure 10: Displays the quantification of the qRT-PCR performed on deleted stem loop 1, as compared to the control, 36c1.

Finally, just as was performed in mutant flies with stem loop 6 deleted, the level of pgc protein in dsL1 was normalized to the level of EGFP mRNA expression in dsL1. The graph of this normalization is shown below.

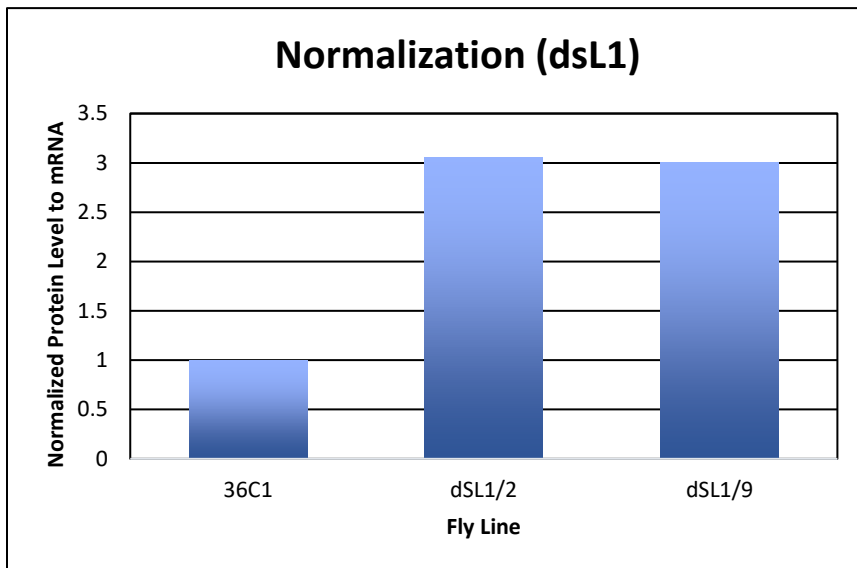

Figure 11: Shows the normalization of protein to the mRNA in flies with stem loop 1 deleted. The 36c1 fly line was used as a control for comparison.

Next, an antibody staining was completed of the ovaries of flies with stem loop 1 deleted. Both the Vasa and GFP channels of the confocal microscope were used to complete this analysis.

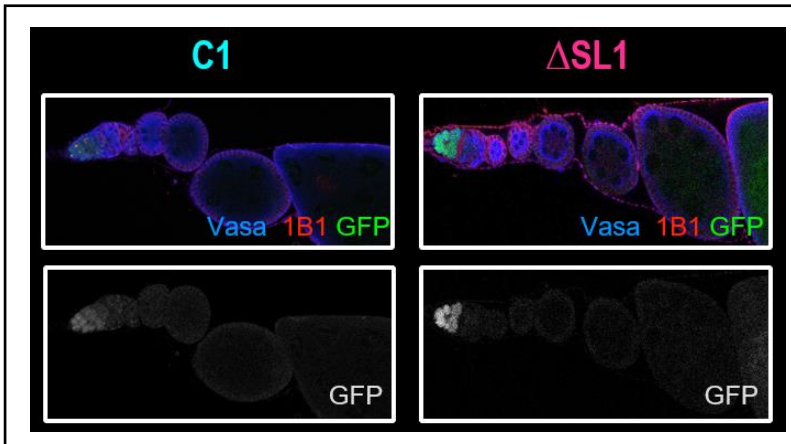

Figure 12: An image from confocal microscope showing the ovaries of a fly line with stem loop 1 deleted compared to the control. The Vasa channel is shown on the top and the GFP channel is shown on the bottom.

Stem Loop 1 Analysis: Embryogenesis

The same procedure that was completed in order to understand oogenesis in transgenic flies was used to understand embryogenesis. However, instead of performing experiments on the ovaries of these transgenic flies, the embryos were used. First, a western blot was completed in triplicate for the dsL1 transgenic flies. The western blot shown below was obtained after analysis of the dsL1/9 transgenic fly line.

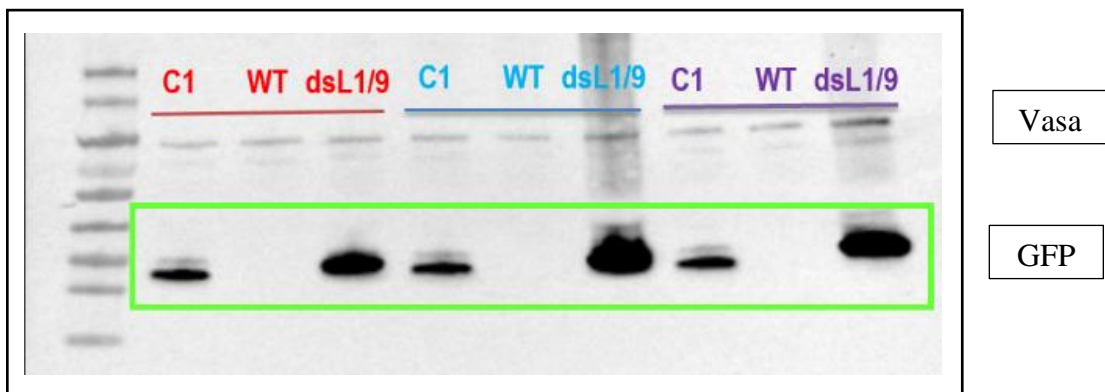

Figure 13: Shown here is the western blot performed on the embryos of dsL1 transgenic flies. Three biological samples of each line were run once, to avoid running three separate blots. The control and wild type flies were also included for comparison.

This western blot was then quantified. The results of this quantification are shown below.

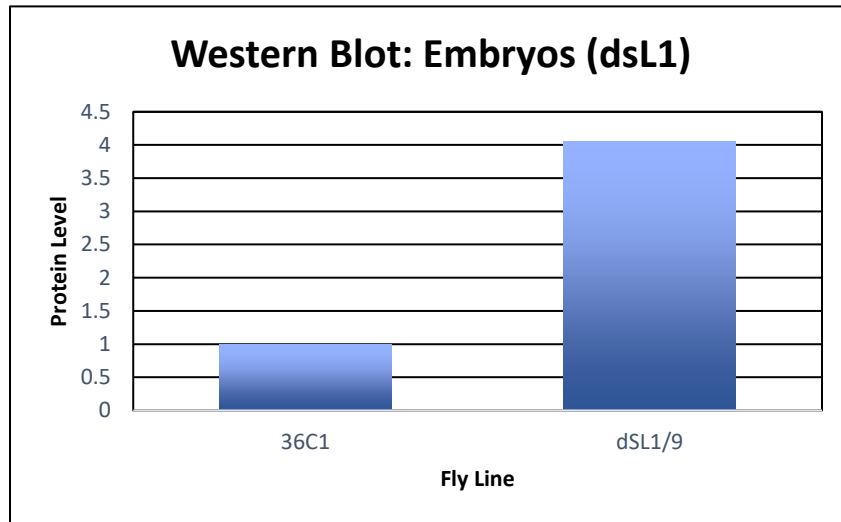

Figure 14: The quantification of the western blot of the embryos of the transgenic dsL1 fly line.

Next, a qRT-PCR analysis was completed on the embryos of the dsL1 transgenic fly line. The results of this experiment are shown below.

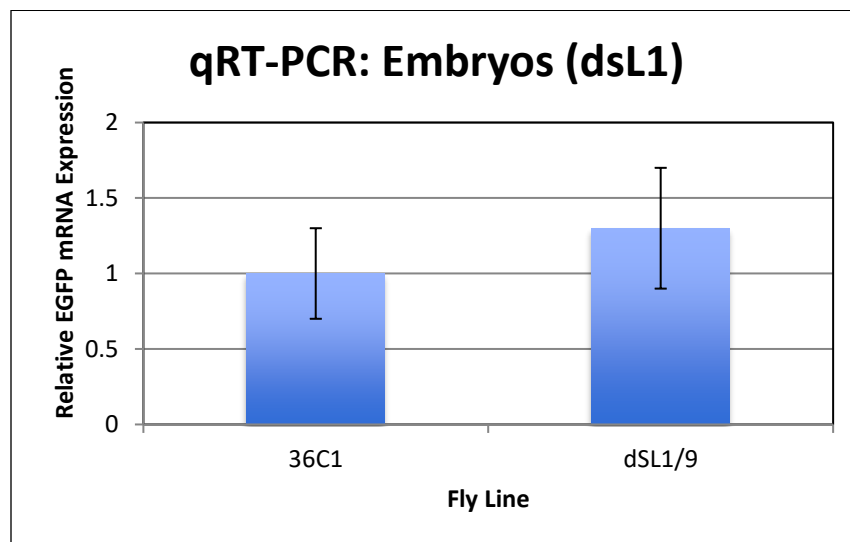

Figure 15: This graph shows the quantification of the qRT-PCR experiment that was performed, to determine the level of mRNA in the embryos of transgenic dsL1 flies.

Finally, a normalization of the level of protein to mRNA was completed, to determine whether the pgc gene was upregulated, downregulated, or unchanged in the embryos, after deleting stem loop 1.

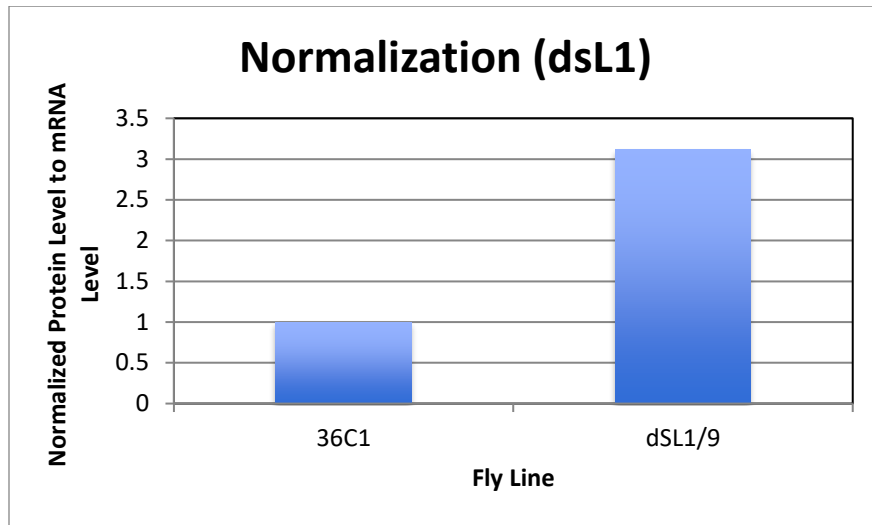

Figure 16: The normalization of protein level to mRNA in embryos of transgenic dsL1 flies is shown in this graph.

Finally, an antibody staining was completed for the embryos dsL1 transgenic flies. This image is shown below.

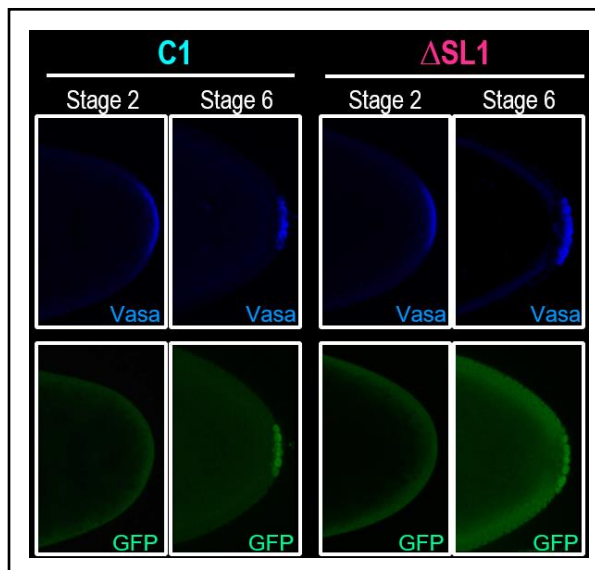

Figure 17: This image shows the embryos of flies with stem loop 1 deleted, under the Vasa and GFP channel, as compared to control (36c1) fly.

Stem Loop 10 Analysis: Embryogenesis and Oogenesis

Transgenic flies that had stem loop 10 deleted were analyzed. The antibody stainings performed on the ovaries and the embryos are shown below.

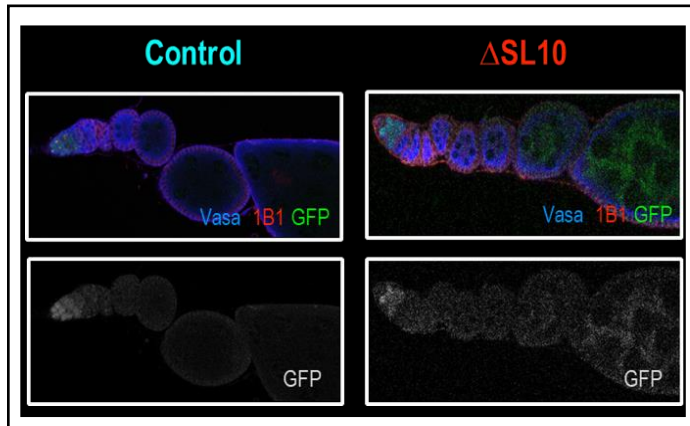

Figure 18: This figure shows the ovaries of transgenic flies that had stem loop 10 deleted, as compared to the control ovaries.

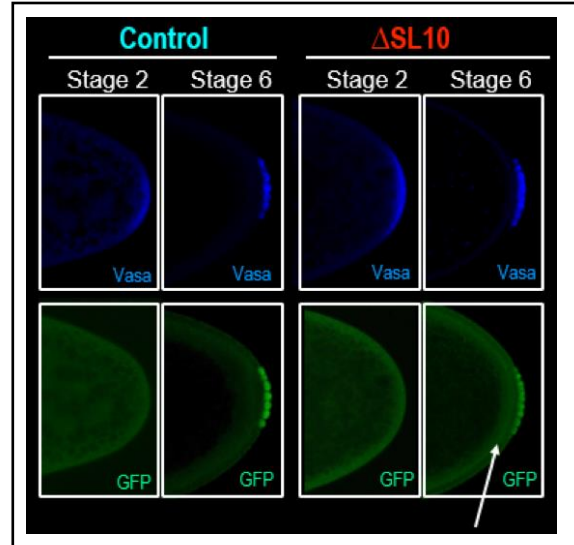

Figure 19: This figure shows the embryos of transgenic flies that had stem loop 10 deleted, as compared to the control embryos.

As in the previous experiments, a western blot was completed in triplicate, and a qRT-PCR experiment was run on the embryos and ovaries of the flies that had stem loop 10 deleted. Instead of showing each graph for western blot, qRT-PCR, and normalization, just the normalization graph is shown below. This graph shows the normalized protein expression, in both oogenesis and embryogenesis, to the expression of mRNA in transgenic flies with stem loop 10 deleted.

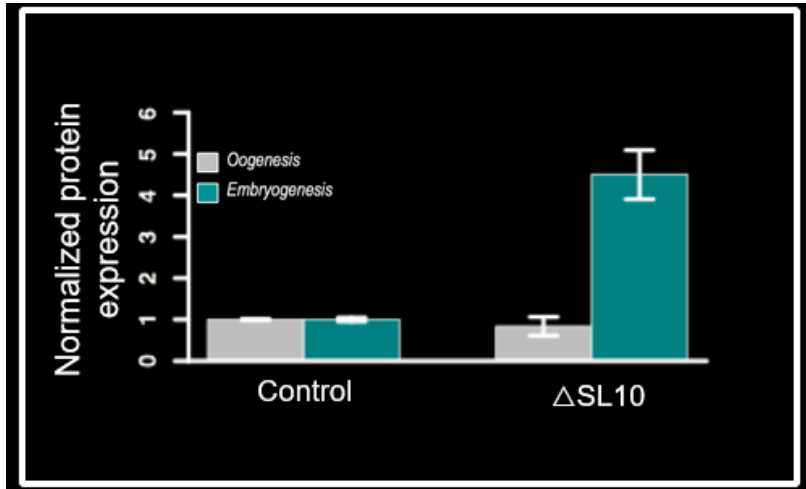

Figure 20: Normalized protein expression after completion of western blot (in triplicate) and qRT-PCR experiments on flies with stem loop 10 deleted. Normalized protein expression in embryogenesis and oogenesis are compared to one another in transgenic flies and control flies.

Protein YT521B Depletion: Oogenesis

In order to see whether there was an interaction between stem loop 10 and RNA binding protein YT521B during oogenesis, the transgenic flies that had stem loop 10 deleted and the CRISPR-Cas mutant flies that had protein YT521B depleted were crossed with each other. There were three different YT521B mutants. A western blot was then run in triplicate on the ovaries of these flies, and the following results were obtained.

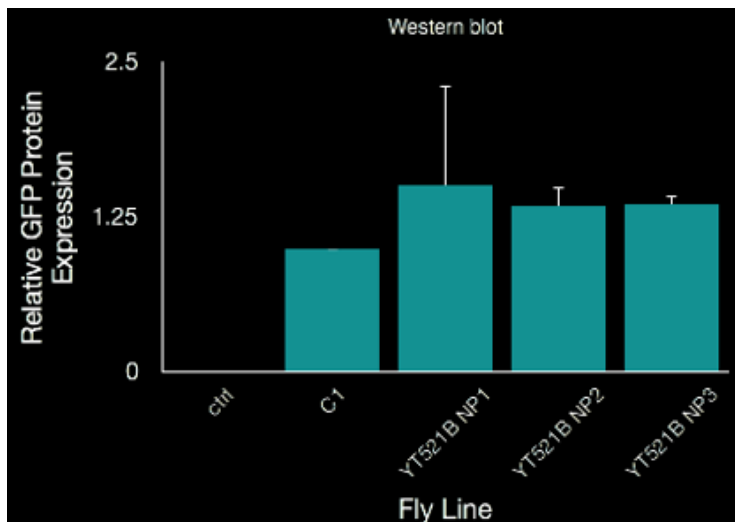

Figure 21: Shows the different levels of pgc protein in each of the YT521B mutants during oogenesis after quantification of the western blot.

Next, a qRT-PCR experiment was completed on the ovaries of these flies. The following results were obtained.

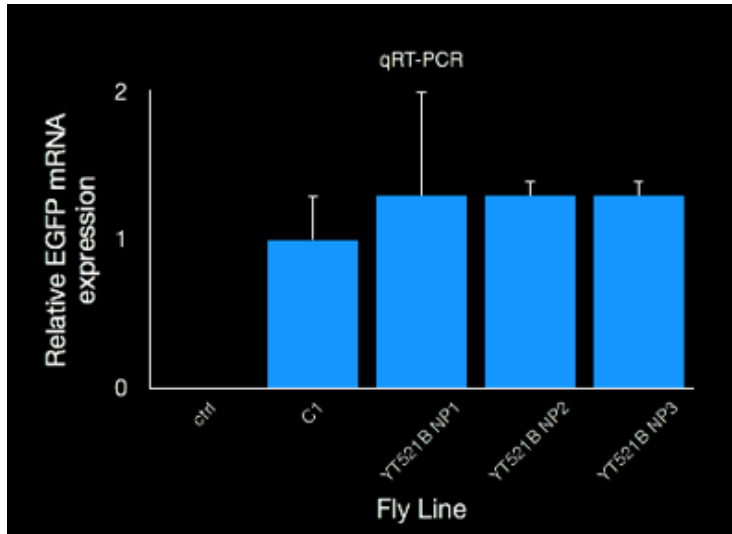

Figure 22: Shows the different levels of EGFP mRNA expressed in the different YT521B mutants after quantification of the qRT-PCR.

Finally, the results of the western blot were normalized to the results of the qRT-PCR, in order to determine the normalized protein expression. The graph below shows this normalization.

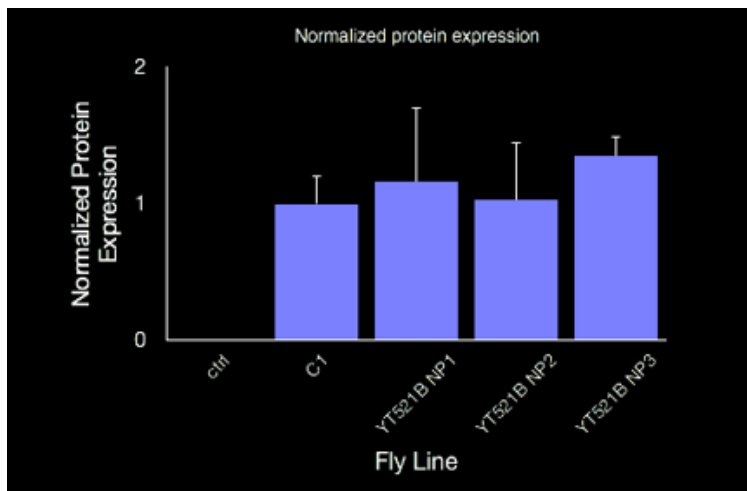

Figure 23: Shows the normalization of the protein to the EGFP mRNA expression in the ovaries of YT521B mutants. There was no significant difference between the normalized protein levels in the control and mutants.

Protein YT521B Depletion: Embryogenesis

Next, protein YT521B depletion in embryogenesis was analyzed. A western blot was completed in triplicate on the embryos of these flies. The results of the western blot experiments are quantified below.

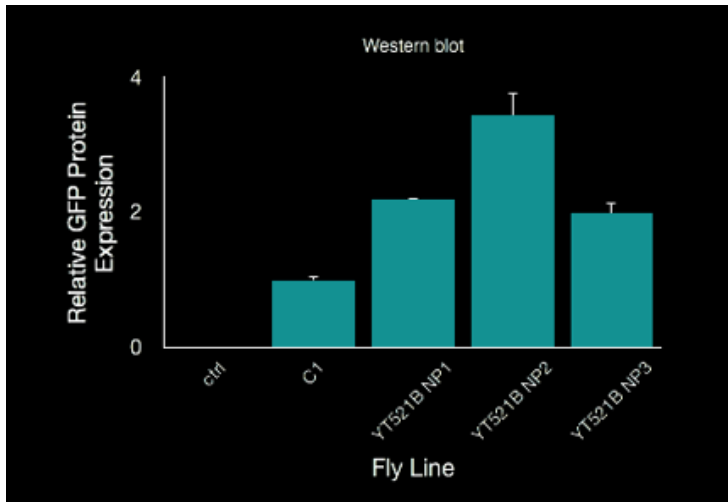

Figure 24: Shows the quantification of the western blot, completed in triplicate, on the embryos of the YT521B mutants, as compared to the control.

Next, a qRT-PCR was completed on the embryos of these flies, in order to determine the relative expression of mRNA in these flies during embryogenesis. The results of this experiment are shown below.

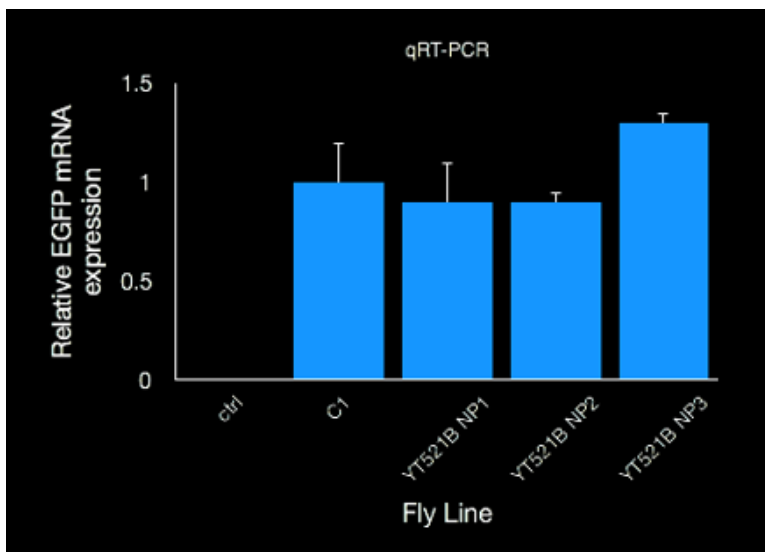

Figure 25: Shows the quantification of the qRT-PCR experiment, completed on the embryos of the YT521B mutants, as compared to the control.

Finally, the results from the western blot experiments were normalized to the results of the qRT-PCR experiment, in order to obtain the normalized protein expression. The results of this experiment are shown below.

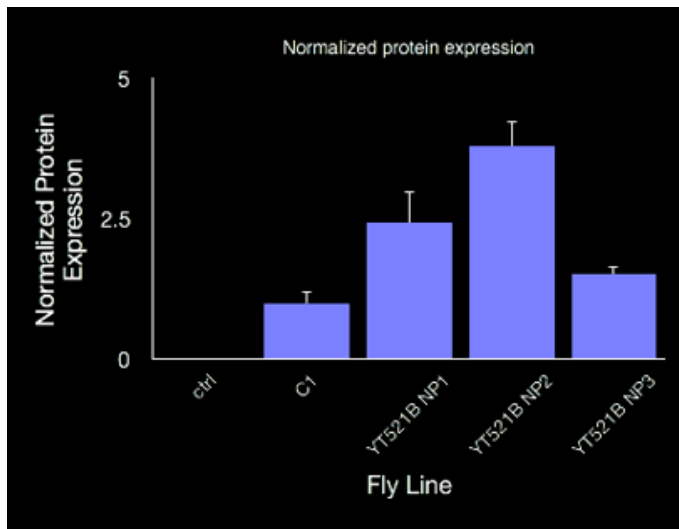

Figure 26: Shows the normalization of the level of protein to EGFP mRNA expression in the embryos of the YT521B mutants. There was a significant difference in expression between the mutants and the control flies.

EMSA Staining

To ensure that RNA binding protein YT521B was actually binding to stem loop 10, an electrophoretic mobility shift (EMSA) was performed. The YTH domain for protein YT521B was purified and tested. The results of this experiment are shown below.

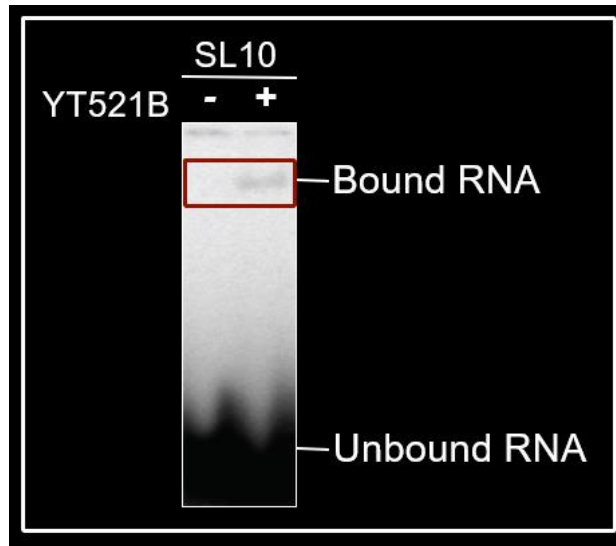

Figure 27: Shows the image of the performed EMSA. The RNA bound to stem loop 10 is shown in the red box. The unbound RNA is displayed at the bottom of the image.

Discussion

The data collected from antibody staining, western blots, and qRT-PCR experiments, were analyzed, to determine if there was a phenotypic change in the flies with deleted stem loops, as compared to the flies with normal stem loop expression. If there were higher levels of RNA expressed than expected, as determined through qRT-PCR, and there were also similar high levels of protein expressed, as determined through western blot analyses, then it could be determined that this deleted stem loop was not causing a problem with the control of translation. Rather, this was upregulation was occurring due to where the transgene was inserted into the *pgc* 3'UTR. If qRT-PCR determined that the level of RNA was at an expected level, yet there was a higher or lower amount of protein than should have been present in the cell, as determined by the western blot, then we can assume that this stem loop has a role in translation control. In order to

come to these conclusions, the level of RNA and the level of protein must be normalized.

Additionally, antibody staining experiments were used in order to observe the visible changes that the deletion of certain stem loops caused in the transgenic flies.

Deletion of stem loop 6 is not significant during oogenesis

First, antibody stainings of the ovaries of transgenic flies with stem loop 6 deleted (dsL6) were compared to the control. There was no observable difference between the ovaries of these two types of flies, as determined through use of the confocal microscope. A western blot was completed to determine if there was a difference between the two fly lines that could not be determined via antibody staining.

The image of the western blot of dsL6 ovaries, as well as the quantification of the western blots completed in triplicate, showed that the level of pgc protein in the dsL6 transgenic flies was relatively the same as the pgc protein level in the control. When observing the level of protein expressed in the image of the western blot, as stained with GFP, the three dsL6 samples appear to have the same amount of protein expressed as the control. Vasa protein was also stained for, as a control. Vasa protein occurs normally in our fly lines, so it was used as a control to quantify our blots. The lanes on the western blot should show relatively the same amount of Vasa protein. When looking at the image of the western blot, the level of Vasa appears to be the same for each sample, so the level of Vasa determined can be used to normalize the GFP staining. This process was used for each western blot completed, in order to quantify our data.

The qRT-PCR experiment performed on the dsL6 ovaries showed that there was no significant difference between the level of EGFP mRNA expressed in the ovaries of the control flies, as compared to the ovaries of the dsL6 flies, after standard error was taken into

consideration. Finally, the level of pgc protein in control flies and dsL6 flies was normalized to the level of mRNA. No significant difference was observed between the normalized level of pgc protein in dsL6 flies, as compared to control flies. After this normalization was completed, it was concluded that there was no upregulation or downregulation of the pgc gene in oogenesis, when stem loop 6 was deleted.

Deletion of stem loop 6 is not significant during embryogenesis

The embryos of transgenic dsL6 flies were also observed via antibody staining using a confocal microscope, to observe the phenotypic differences (if any) between the dsL6 embryos and control embryos. The antibody staining showed no phenotypic difference between the control and dsL6 flies, so no further investigation of dsL6 was conducted. dsL6 flies appeared identical to control flies in both stage 2 (an early embryo stage) and stage 6 (later stage of development). In stage 6, the pgc, as shown through the GFP channel, should be localized to the pole cells, as is observed. After investigating both the ovaries and embryos of dSL6 flies, it was concluded that the deletion of stem loop 6 does not cause upregulation or downregulation of the pgc gene and therefore has no bearing on translational control in the cell.

Deletion of stem loop 1 causes 3-fold upregulation of pgc gene in oogenesis

Next, the dSL1 flies were analyzed for a phenotype in oogenesis under the confocal microscope through antibody staining. In these images, through use of the Vasa and GFP channels, it is apparent that there is a higher expression of GFP in the ovaries. This phenotype needed to be quantified, so a western blot was performed on these ovaries.

Once again, using Vasa as our control, and staining for GFP protein to see the level of pgc protein in the ovaries, it was determined that there was a much higher level of pgc protein in

these cells than was in our positive control. Next, a qRT-PCR was performed, in order to determine the level of EGFP mRNA expression in the ovaries. While completing this experiment, we determined there was about the same level of mRNA in both the control and transgenic dsL1 flies. However, there was an extremely high level of error in dsL1/2 transgenic flies in the qRT-PCR, after quantification. Therefore, it was decided to not use the dsL1/2 fly line for further experimentation, and instead use dsL1/9. The standard error determined through quantification of the qRT-PCR of dsL1/9 flies was much lower.

Finally, the level of pgc protein in dsL1 fly line and the control was normalized to the level of EGFP mRNA expressed. It was determined that there was a 3-fold upregulation of the pgc gene of the dsL1 fly line, when compared to the control fly line, indicating that stem loop 1 plays an important role in translation control. When this stem loop was deleted, the translation of the pgc gene did not occur properly. As indicated by the 3-fold upregulation, there was a loss of translational regulation.

Deletion of stem loop 1 causes 3-fold upregulation of pgc gene in embryogenesis

Next, an antibody staining of the embryos from flies with stem loop 1 deleted (dsL1) was examined. Here, there appeared to be a loss of translational control of pgc in the pole cells, as determined under the GFP channel. Pgc should be localized completely to the pole cells by stage 6 of embryogenesis, yet pgc can be seen expressed both inside and outside of the pole cells, indicating that translation did not occur properly. It was necessary to quantify these results, so a western blot was completed in triplicate to measure pgc protein levels and qRT-PCR was completed to quantify EGFP mRNA expression in dsL1 embryos

After performing a western blot analysis, it was immediately apparent that there was a greater amount of pgc protein in dsL1 embryos, as compared to the control. When the western blot was quantified, it was determined that the pgc protein level had increased 4-fold, when the dsL1 was compared to the control. Next, a qRT-PCR was performed, to determine the level of EGFP mRNA expressed in the dsL1 embryos. This qRT-PCR showed that there was about the same level of mRNA expressed in both control flies and in dsL1, after calculating standard error. Finally, these results were normalized. After normalization, a 3-fold upregulation of the pgc gene was determined. When stem loop 1 is deleted, there is a loss of translational control in both embryogenesis and oogenesis (as discussed previously).

Deletion of stem loop 10 causes 5-fold upregulation of pgc gene in embryogenesis

The embryos and ovaries of flies that had stem loop 10 deleted were first analyzed via antibody staining and use of the confocal microscope. These images showed a loss of translational regulation embryogenesis. In embryogenesis, this loss is evident in the pole cells, as GFP (indicating the expression of pgc protein), is expressed throughout the embryo, rather than being localized to the pole cells. On the other hand, no phenotypic difference was observed in the ovaries of dsL1 flies. It was hypothesized that dsL1 is important for translational regulation during embryogenesis, but not during oogenesis.

A western blot was completed in triplicate, to determine the level of pgc protein expressed in ovaries and the embryos. A qRT-PCR experiment was also run, to determine the EGFP mRNA expression, to determine the level of pgc mRNA expressed in the ovaries and embryos. After completion of these experiments, the results were normalized to each other, and shown on one graph in the results. It was determined that there was no significant change in regulation during oogenesis when stem loop 10 was deleted. However, there was a significant

upregulation of the *pgc* gene during embryogenesis, when stem loop 10 was deleted. It was hypothesized that an RNA binding protein may be interacting with stem loop 10, in order to control translation.

Depletion of protein YT521B causes no change in regulation in oogenesis

After deletion of stem loop 10, there was determined to be an increase in the level of normalized protein expression during embryogenesis, however this increase was not observed during oogenesis. It was hypothesized this discrepancy was due to a protein, specifically the RNA binding protein YT521B, binding to this stem loop during embryogenesis, and not during oogenesis, in order to control translational regulation. Protein YT521B is a protein that has a YTH domain to recognize specific conserved sequences. One of these sequences is found in stem loop 10, which allowed my colleagues to generate this initial hypothesis. Since *pgc* 3'UTR mRNA is a unique and dynamic secondary structure it can allow binding of YT521B to occur at some time points of development (embryogenesis) and not during others (oogenesis).

To investigate this hypothesis, fly mutants in which YT521B was depleted were created using a CRISPR-Cas method. These flies were crossed with those who had stem loop 10 deleted. A western blot was completed in triplicate on the ovaries of these flies. There was no significant difference during oogenesis in *pgc* protein level compared in YT521B mutants, as compared to the control flies. A qRT-PCR was also completed. No significant difference in EGFP mRNA expression during oogenesis was determined in the YT521B mutant flies, as compared to the control flies. Finally, the results from the western blot and the qRT-PCR were normalized. This normalization revealed that depletion of protein YT521B caused no significant change in translation regulation during oogenesis. This was expected, as protein YT521B and

stem loop 10 were believed to be interacting, and deletion of stem loop 10 caused no significant change in translation regulation during oogenesis.

Depletion of protein YT521B causes significant upregulation in embryogenesis

The same transgenic flies with depletion YT521B were once again used, except the embryos of these flies were used for experimentation. As a deletion of stem loop 10 caused a loss of translation regulation during embryogenesis, and protein YT521B was believed to be interacting with stem loop 10, it was hypothesized that a depletion of YT521B would also cause a loss of translation regulation during embryogenesis. A western blot was completed in triplicate. Quantification of these western blots showed a significant change in protein expression, as compared to the control. A qRT-PCR was also completed. Quantification of this experiment showed no significant change in the expression of EGFP mRNA. These results were then normalized. This normalization revealed that depletion of protein YT521B caused a loss of translation regulation, as was expected.

Protein YT521B and stem loop 10 interact in embryogenesis

Finally, to conclusively state that protein YT521B and stem loop 10 were interacting during embryogenesis, an electrophoretic mobility shift (EMSA) was performed. The YTH domain for YT521B protein was purified and tested. The results of this experiment allow us to conclude, with confidence, that YT521B is binding to stem loop 10. The bottom of the EMSA shows unbound RNA. When the protein and stem loop 10 RNA are bound, they form the RNA protein complex, as indicated by the fainter band on the assay. This supports the hypothesis, that stem loop 10 is a target for RNA binding protein YT521B, and this binding is required to control translation

Conclusions & Future Directions

After analysis of multiple stem loops, it was determined that stem loop 6 does not control translation during oogenesis or embryogenesis. Stem loop 1 controls translation regulation, as a deletion of this stem loop caused a 3-fold upregulation of the *pgc* gene during oogenesis and a 3-fold upregulation of the *pgc* gene during embryogenesis. Stem loop 10 controls translation regulation, but only during embryogenesis. A deletion of stem loop 10 in oogenesis caused no phenotypic change, however a deletion of stem loop 10 in embryogenesis caused a significant upregulation of the *pgc* gene. A depletion RNA binding protein, YT521B, caused a loss of translation regulation during embryogenesis, but not oogenesis, as was hypothesized. It was firmly concluded that protein YT521B and stem loop 10 are directly interacting with one another during embryogenesis.

In the future, point mutations may be made in the loop structure to test its role during *pgc* translation regulation. Additionally, IP experiments could be carried out with YT521B antibody, to test if *pgc* RNA associates with YT521B *in vivo*. This research allows important conclusions to be drawn regarding the importance of stem loop structures during conserved developmental processes. The complete understanding of these processes in *D. melanogaster* can help researchers draw conclusions about developmental processes in other, more complex, organisms

References

- Dansereau, D., & Lasko, P. (2009). The development of germline stem cells in *Drosophila*. *Methods in Molecular Biology*, 450(1), 3-26. doi:10.1007/978-1-60327-214-8_1
- Flora, P., Schowalter, S., Wong-Deyrup, S., DeGennaro, M., Nasarallah, M., & Rangan, P. (2018). Transient transcription silencing alters the cell cycle to promote germline stem cell differentiation in *Drosophila*. *Developmental Biology*, 434(1), 84-95.
- Gebauer, F., Preiss, T., & Hentze, M. (2012). From Cis-Regulatory elements to complex RNPs and back. *Cold Spring Harb Perspect Biol*. doi:10.1101/cshperspect.a012245
- Jennings, B. H. (2011). *Drosophila* – a versatile model in biology & medicine. *Materials Today*, 14(5), 190–195. [https://doi.org/10.1016/S1369-7021\(11\)70113-4](https://doi.org/10.1016/S1369-7021(11)70113-4)
- Kramer, S., & Carrington, M. (2011). Trans-acting proteins regulating mRNA maturation, stability and translation in trypanosomatids. *Trends in Parasitology*, 27(1), 23–30. <https://doi.org/10.1016/j.pt.2010.06.011>
- Lehmann, R. (2016). Germ plasm biogenesis- an Oskar-centric perspective. *Current Topics in Developmental Biology*, 116, 679-707. doi:10.1016/bs.ctdb.2015.11.024
- Lence, T., Akhtar, J., Bayer, M., Schmid, K., Spindler, L., Ho, C.H., Kreim, N., Andrade-Navarro, M., Poeck, B., Helm, M., & Roignant, J. (2016). M⁶A modulates neuronal functions and sex determination in *Drosophila*. *Nature*, 540(7632), 242-247. doi:10.1038/nature20568

Nakamura, A., Amikura, R., Mukai, M., Kobayashi, S., Lasko, P. (1996). Requirement for a noncoding RNA in *Drosophila* polar granules for germ cell establishment. *Science*, 274(5295): 2075-9.

Rangan, P., DeGennaro, M., Jaime-Bustamante, K., Coux, R.-X., Martinho, R. G., & Lehmann, R. (2009). Temporal and Spatial Control of Germ-Plasm RNAs. *Current Biology*, 19(1), 72–77. <https://doi.org/10.1016/j.cub.2008.11.066>

Zhang, Z., Theler, D., Kaminska, K. H., Hiller, M., de la Grange, P., Pudimat, R., ... Stamm, S. (2010). The YTH domain is a novel RNA binding domain. *Journal of Biological Chemistry*, 285(19), 14701–14710. <https://doi.org/10.1074/jbc.M110.104711>