

## Fly Ash Particle Reinforced And Mechanical Properties Of AL6061GraphiteB<sub>4</sub>C Composites

**D. Ramesh Kumar, B. Shanmugasundaram, P. Mohanraj**

Faculty, Department of Mechanical Engineering,  
Adithya Institute of Technology, Coimbatore  
E-Mail: [bshan\\_india@rediffmail.com](mailto:bshan_india@rediffmail.com)

### Abstract

*Fly ash particle reinforced with aluminum alloy composite materials used for various industrial applications like automobile, aerospace, aircrafts, substrate in electronics, turbine blades, brake pads, golf clubs and it is also used in home products. Metal matrix composites (MMCs) possess increased mechanical properties like strength, yield strength, hardness, impact strength and to improve fracture toughness when compared to unreinforced alloys. The main aim is to fabricate Al6061/Fly ash, Boron Carbide, Graphite, and also Magnesium metal matrix composite by using stir casting process and also to study the mechanical properties of the fabricated composite material. Fly ashes with aluminum, composite materials have good mechanical and physical properties at very high temperature, they are resistant to wear and are used in lowest weight purposes. Aluminum composite prepared from liquid phase reaction presents a unique microstructure. The each phase is a connected network pervaded by the network of the other constituent. It is an improved composite having less cost and lowest density reinforcements. The fly is very cost-effective and very low density reinforced in solid waste by the product during combustion of coal in thermal power plants. Hence, fly ashes with aluminum composites reinforcement are used to overpower the cost for wide applications in automotive ancillaries, aircrafts, turbine blades and also engine. In future we add the graphite, boron carbide and magnesium with Al6061 & Fly ash to produce other metal matrix composites.*

**Keywords:** Fly ash, Wear resistant, Metal–matrix composites (MMCs), Casting, Particle-reinforcement.

### INTRODUCTION

In large number of industrial applications, the important parameter in material selection is specific strength. Metal Matrix Composites (MMCs) are suitable applications required joined strength, thermal conductivity, damping properties and lowest coefficient of thermal expansion with low density. These properties of MMCs increase their usage in automotive and other industrial applications. MMCs are used in the field of automobile, for pistons, cylinder block and brake drum due to good corrosion resistance and wear resistance. Reinforced composites with ceramic phases expose high strength, high elastic modulus and

also improved resistance to wear, creep and fatigue, which make them better structural materials for aeronautical and automobile industries. These composites also undergo from a big loss in ductility and toughness because of inclusion of non-deformable ceramic reinforcements, which limits their applications to a certain extent.

Conventional monolithic materials have certain drawbacks to attain good combination of strength, rigidity, toughness and density. Density of fly-ash subjects to the formation of light weight insulating composites. Inclusion of a second phase into a metal matrix can improve the physical and mechanical

properties and importantly changing its corrosion behavior. The corrosion behavior of composites is determined by various aspects such as formation of alloy, the matrix microstructure, and the techniques applied for making the composite. Hence, flyash reinforced with aluminum composites are used to affect the cost barrier for wide area purposes in automotive and small engine. Therefore fly ash particles with aluminum alloy will build up low-cost waste by-product and cutting down the expense of aluminum products.

Flyash with aluminum composites provide more potential uses for internal combustion engine, pistons and brake rotors on the ground of their density and high mechanical properties.

The published literature signified advanced materials like aluminum Fly Ash

(ALFA) composites, which is primarily concerned with usage of fly ash particles for combination of these materials. This occurs because of incomplete information on the influence of fly ash particles on the susceptibility of aluminum fly ash composites to corrosion. Therefore, to study:

1. The micro-structural characteristics of aluminum composites material reinforced in fly ash particles.
2. The relationship between the metal matrix composite microstructure and corrosion behavior in one type of corrosive environment. The present work is dedicated to an investigation.
3. The particulate composite is processed by injecting the reinforcing particles into liquid matrix through liquid metallurgy.

## **METHODOLOGY**

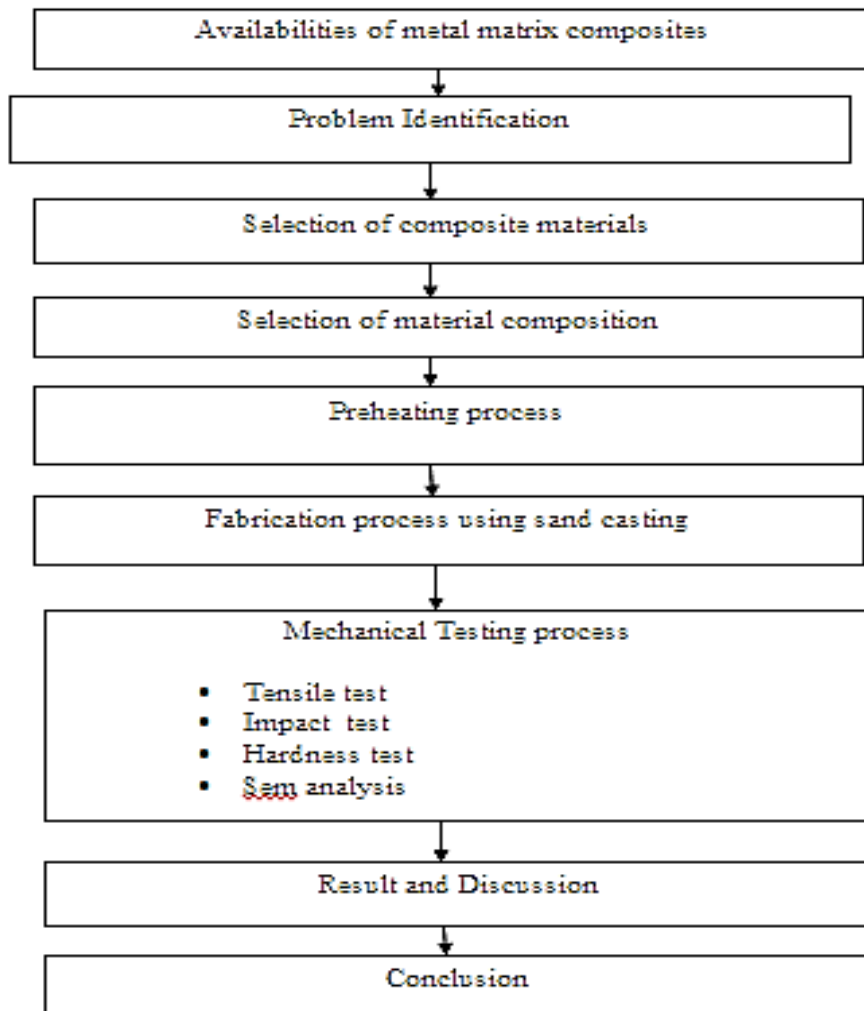

*Fig.1 Flow Chart for Methodology*

**Fabrication and Testing Process**

**Stir Casting Process**

Stir casting is a process of liquid state fabrication of composites which involves inclusion of diffused phase into a molten metal, succeeded by its solidification. Effective interfacial wetting between the diffused phase and elevated mechanical nature of the composite materials are due to stir casting process help in getting liquid matrix. The interfacial wetting can be achieved by coating the diffused phase particles. Adequate coating leads to stop the chemical interaction between the dispersed phase and the composites matrix hence, it cannot decrease interfacial energy.



*Fig.2. Stir Casting Setup*

Stir Casting is a standout amongst the most practical techniques for fluid state

manufacture. Blend Casting is a creation of metal framework composites, in which artistic particles, strands is blended into a liquid metal network by methods for mixing strategy. The fluid state creation composite material is customary throwing strategies and can likewise be handled by traditional Metal framing advances. The real points of interest of this procedure have been creating spasmodic molecule strengthened metal lattice composites for a considerable length of time and innovation is moderately basic and minimal effort.

### Stir Process Characteristics

- The dispersed content phase is usually not more than 30 %.
- The distribution of dispersed phase throughout the matrix is not perfectly homogeneous.
- There are local clusters of the dispersed fibers particles.
- There are gravity segregation of the dispersed phase due to a difference in the density of the dispersed and matrix phase.
- The technology is very simple and low cost.

### Sand Casting

The Sand casting is procedure of basic and medium for creation, which is reasonable in all aluminum, Zinc, and Copper alloys. The sand throwing procedure is appropriate for the generation and modest number of castings for complex shape throwing required expansive non-ferrous castings. It is the most well known throwing process utilized as a part of industry. The sand is utilized for making sand throwing has fine, round grains that have been firmly stuffed to frame a smooth surface. This process is includes pouring liquid zinc, aluminum into a sand form.



*Fig.3 Sand Casting Process*

The constraints of the sand throwing process is 3 to 5mm least divider thickness, poor direct resistance (e.g. 4mm/m) and coarse grain measure and different contemplations, for example, the complete and machining allowances. The sand casting segments has been spare time and cash.



*Fig.4. Specimen after Casting*

### Tensile test

Test examples has been set up as per ASTM E8-82 principles, every example have 8mm in measurement and 60 mm gage length, as appeared in Fig. 5. The example has stacked in Universal Testing Machine until the disappointment of the example happens.

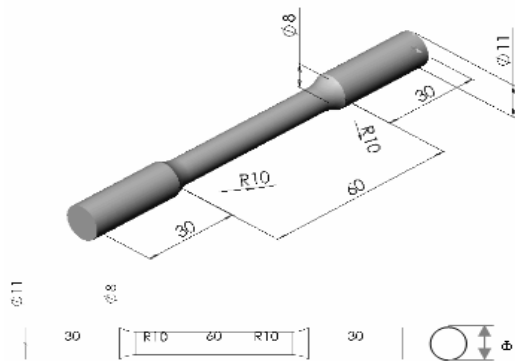

**Fig.5 Tensile Test Specimen**

Tensile tests have been led on composites of various blends of strengthening materials and extreme rigidity and flexibility were measured. The tried example that has been measured for its cross-sectional range and gage length is settled in the testing machine and the extensometer is appended. The readings of load and extension were taken at uniform interims of load.

Uniaxial tractable test has directed on the manufactured example to get data conduct of a given material under progressively expanding anxiety strain conditions. It is done at room temperature by utilizing general testing machine. It can be noticed that the expansion of fly ash and graphite particles has been enhanced the tensile strength of the composites. It is to increment in the volume portion of fly slag molecule comes about and furthermore increment in the tensile strength.



**Fig.6 Tested Tensile Samples**

### Impact Test

The effect test is a dynamic test has been directed on a chosen example which is typically scored. The example is softened by a solitary explode a specially designed machine. It is to quantify vitality ingestion limit and sturdiness of the materials.

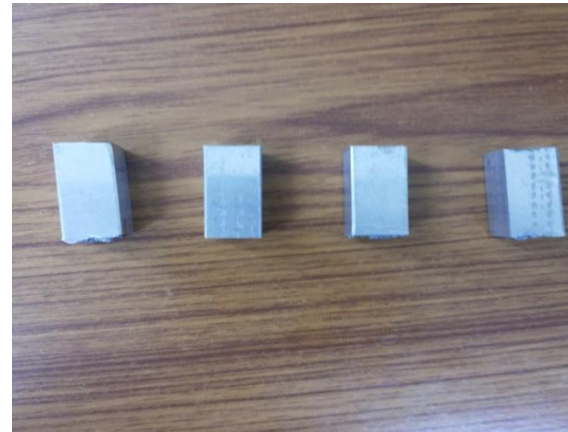

**Fig.7 Impact Test Specimen**

### Hardness Test

The solidified steel ball indenter is constrained into the surface of the metal has been tried by utilizing brinell hardness tester. The width of the solidified steel indenter is 10mm. The standard burdens are connected as a 10 to 15 seconds. Hardness estimations has completed on the metal and composite examples by utilizing brinell hardness test. Brinell hardness estimations have done to research the impact of weight portion on the grid hardness. The 750kg load and steel bundle of 5 mm width indenter has been utilized.



**Fig.8 Hardness Test Specimen**

**Evaluation of Microstructure**

The checking electron magnifying instrument is helpful for watch the geology and morphology of an example. The capacity of SEM is a mapping gadget which examined by electron pillar scanning the surface. It is a technique for electron microscope that delivering pictures of a specimen by checking it with centered light emission. The electrons collaboration with iotas in the example has been creating different signs. It can be recognized and contain data about the specimen's surface topology and composition.



**Fig.9** Specimen for SEM Analysis

**RESULTS AND DISCUSSIONS**

**Tensile Test**

*Table 1: Result for Tensile Test*

Sample	Sample Description	Tensile Strength (N/mm <sup>2</sup> )
1.	Al 6061+5% Graphite+5% B <sub>4</sub> C	90.30
2.	Al 6061+5% Graphite +5% B <sub>4</sub> C +5% Fly Ash	79.27
3.	Al 6061+5% Graphite+5% B <sub>4</sub> C +10% Fly Ash	51.13
4.	Al 6061+5% Graphite+5% B <sub>4</sub> C +15% Fly Ash	96.76

The tensile strength of Sample 3(Al6061+5%Graphite+10% Fly ash) is 51.13 N/mm<sup>2</sup> and this value increases to a maximum of 96.76 N/mm<sup>2</sup> for Sample 4 (Al6061+5%Graphite+15%Fly ash) which is about 35% improvement on that of Sample 3.

**Graph for Tensile Test**

The graph shows the variation of tensile strength of the composites with the different weight fractions of fly ash particles. It can be noted that the tensile strength increased with an increase in the weight percentage of fly ash.

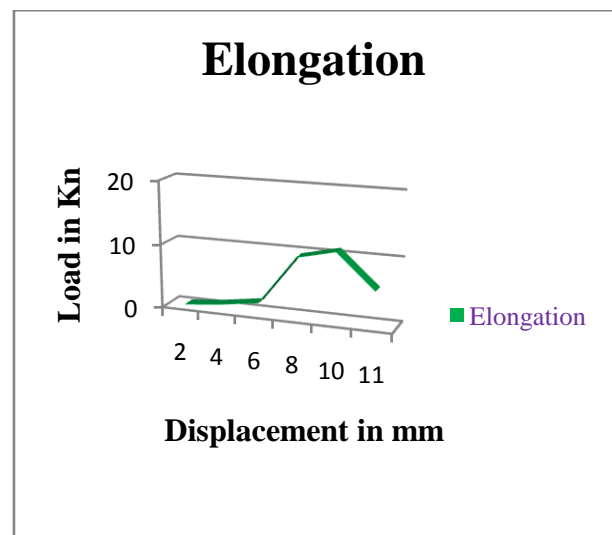

**Fig.10** Sample 1 (Al 6061 +5% Graphite+5% B<sub>4</sub>C)

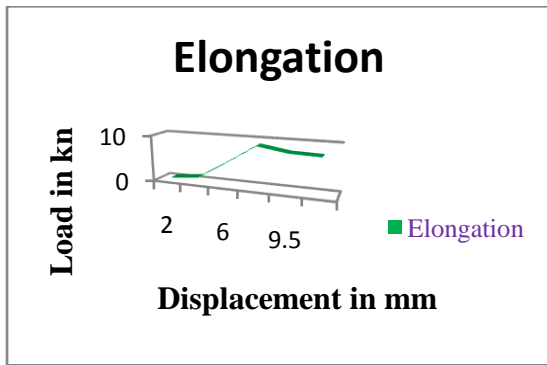

**Fig.11** Sample 2 (Al 6061+5% Graphite +5% B<sub>4</sub>C +5% Fly Ash)

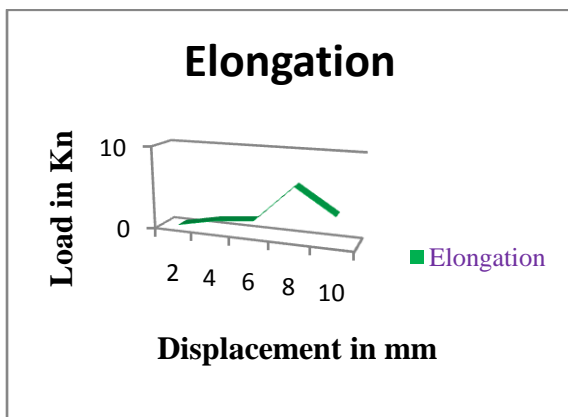

**Fig.12** Sample 3 (Al 6061+5% Graphite +5% B<sub>4</sub>C +10% Fly Ash)

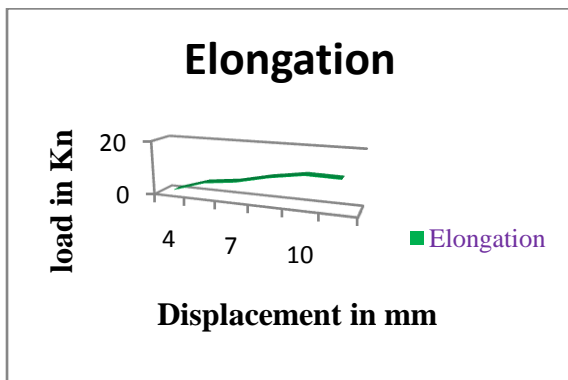

**Fig.13** Sample 4 (Al 6061+5% Graphite +5% B<sub>4</sub>C +15% Fly Ash)

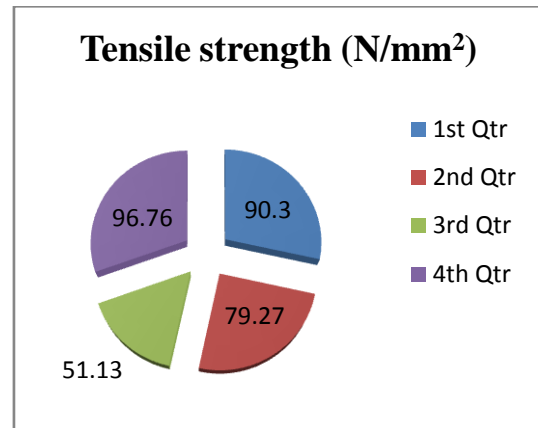

**Fig.14** Comparison Pie Chart for Tensile Test

Figure 14 shows the comparison chart for tensile strength of the composites with the different weight fractions of fly ash particles. The tensile strength of sample 4 having highest value of 96.76 N/ mm<sup>2</sup>.

**Impact Test**

This absorbed energy is a measure of a given material's toughness. Table 2 shows results of impact test.

**Table 2: Result for Impact Test**

Sample	Sample Description	Absorbed Energy (J)
1	Al 6061 +5% Graphite+5% B <sub>4</sub> C	4
2	Al 6061+5% Graphite +5% B <sub>4</sub> C +5% Fly Ash	4
3	Al 6061+5% Graphite +5% B <sub>4</sub> C +10% Fly Ash	3
4	Al 6061+5% Graphite +5% B <sub>4</sub> C +15% Fly Ash	5

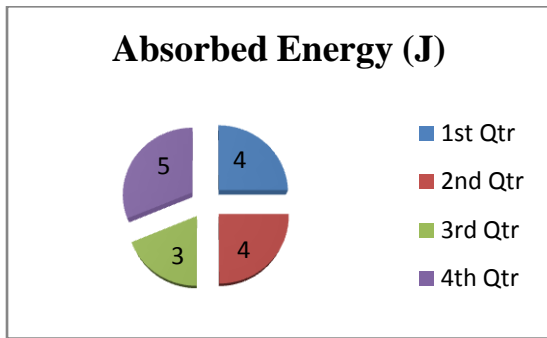

**Fig.15 Comparison Pie Chart for Impact Test**

**Hardness Test**

In the hardness test, a hardened steel ball indenter is forced into the surface of the metal to be tested. The tested values are given below.

From the Figure it is apparent that the hardness of the composite material is considerably higher than that of its parent metal. It is additionally demonstrated that the hardness of the composite material increments with wt % of fly fiery remains content. This might be a result of expansion of fly cinder makes the pliable Al6061 amalgam into more weak in nature with increment in the fly fiery remains content. And furthermore the scattering of fly fiery debris particles upgrades the hardness, as particles are harder than Al6061 combination.

**Table 3 Results for Hardness Test**

Sample	Sample Description	Hardness (BHN)
1	Al 6061+5% Graphite+5% B <sub>4</sub> C	52.0
2	Al 6061+5% Graphite +5% B <sub>4</sub> C +5% Fly Ash	57.5
3	Al 6061+5% Graphite +5% B <sub>4</sub> C +10% Fly Ash	51.5
4	Al 6061+5% Graphite +5% B <sub>4</sub> C +15% Fly Ash	61.2

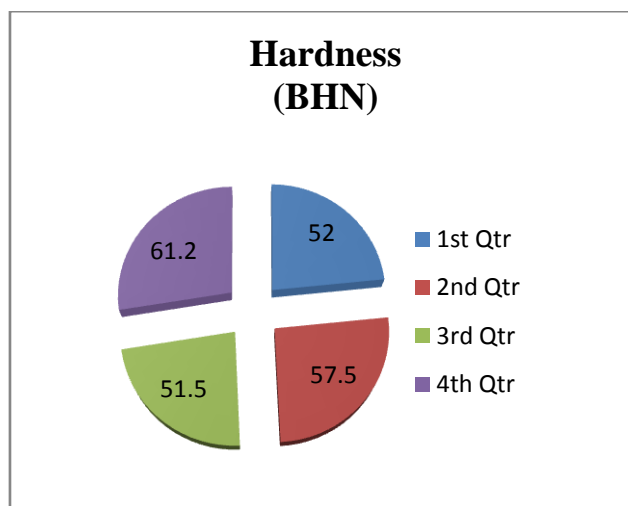

**Fig.16 Comparison Chart for Hardness Test**



**Evaluation of Microstructure**

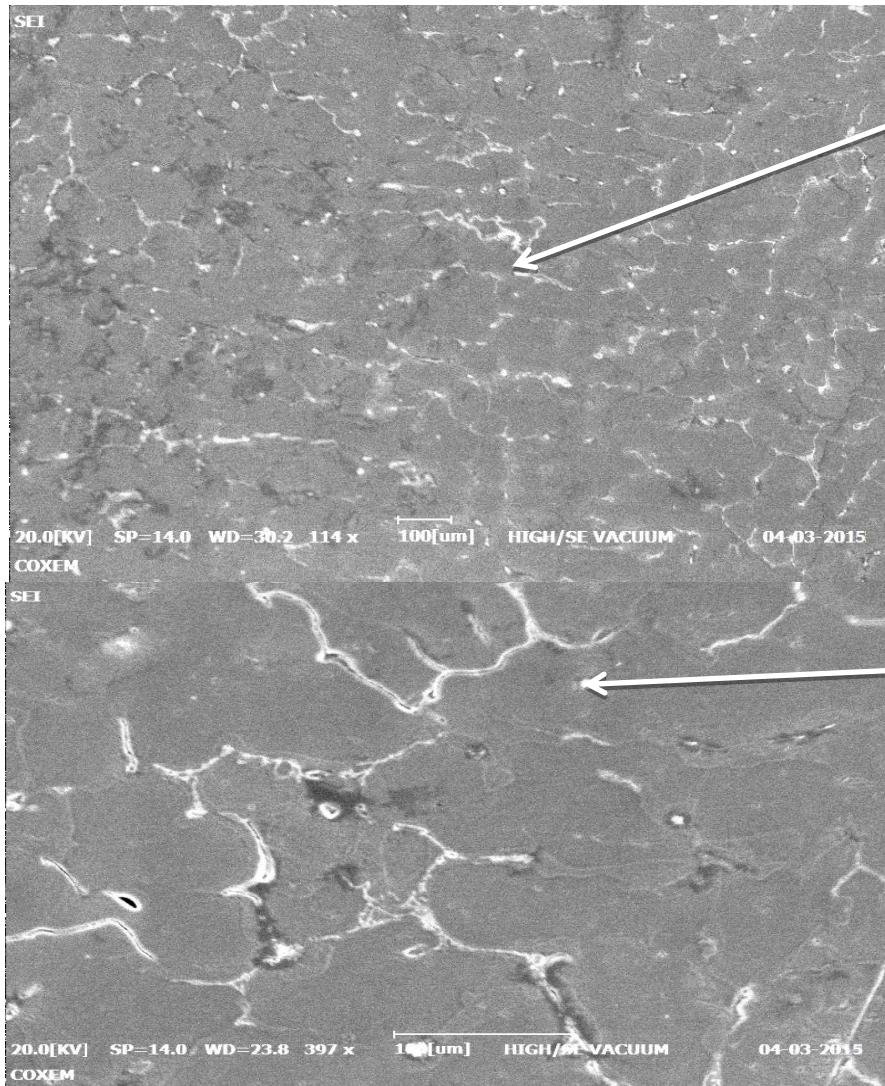

Impurities

Crack

**Fig.17** Microstructure of Al 6061+5% Graphite +5% B<sub>4</sub>C++15% Fly Ash

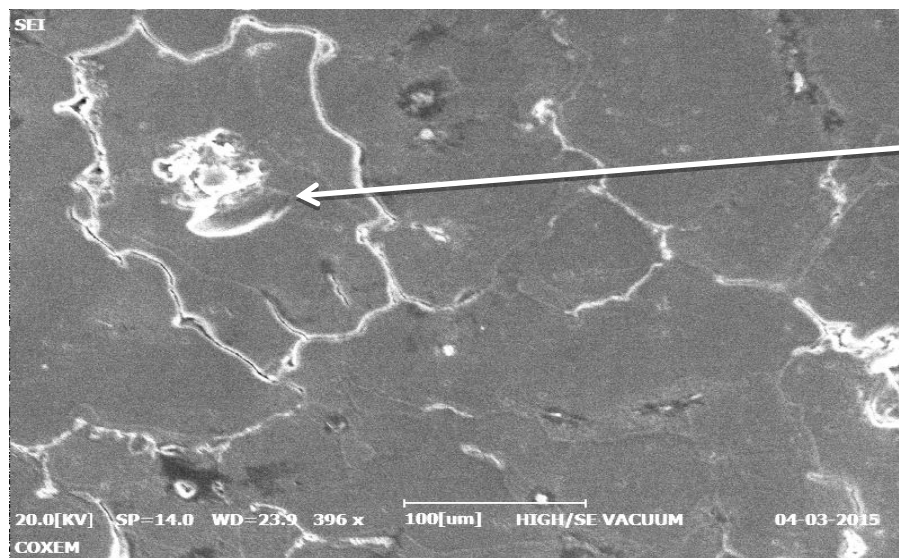

Blow holes

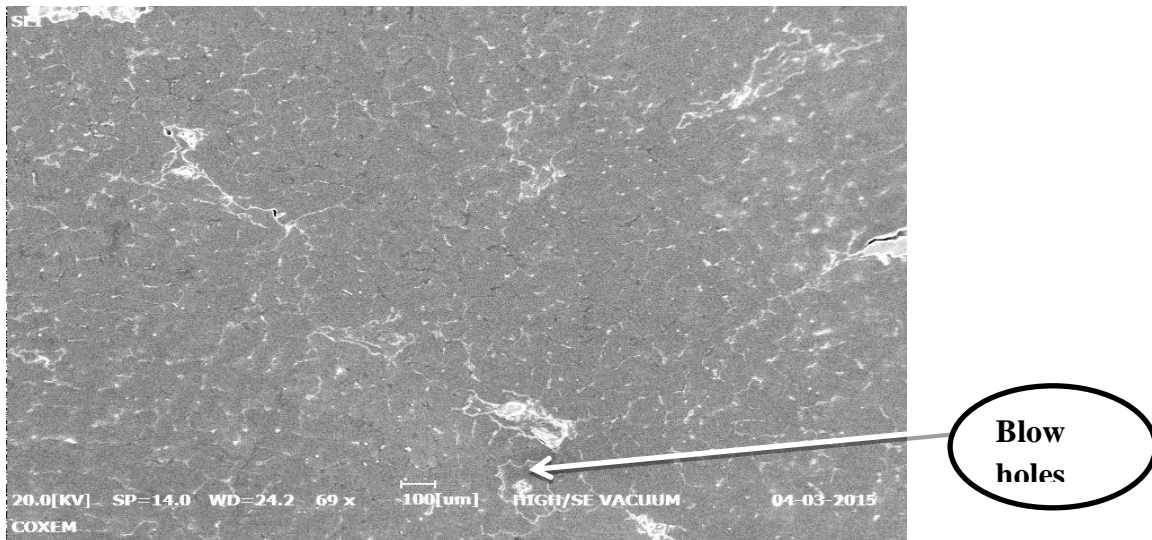

**Fig.18** Microstructure of Al 6061+5% Graphite +5% B<sub>4</sub>C+15% Fly Ash

## CONCLUSION

Research have been done for the proper MMC fabrication technique and selected as stir process. Material selection for matrix material composite has done based on the availability and the required properties. Microstructure determination of fly ash has done using scanning electron microscope. Based on the study conducted on the fly ash, Graphite containing Al6061 composite material, the following conclusions can be made. Using sand casting method, fly ash and Graphite can be successfully introduced in the Al6061 alloy matrix to fabricate hybrid composite material.

From the microstructure investigation it is clear that the composites manufactured have genuinely even conveyance of fortifications in the composite material. The elastic of composite material contrasted with the as cast Al6061 combination, expanded essentially by 60-70%; The change in compressive quality is likewise watched yet it was peripheral. Assist change in compressive conduct of composite can be accomplished by consolidating manufacture strategy other than sand throwing method. The hardness of the composite material likewise expanded with increment in wt% of fly

fiery debris content in the composite. This is because of the fortifying of Al6061 amalgam network by the fly cinder particles.

## REFERENCES

1. A.R. Riahi., A.T. Alpas. (2001). "The role of tribo layers on the sliding wear behavior of graphitic aluminum matrix composites". *Wear* 251, pp 1396-1407.
2. J.An., Y.B. Liu., Y. Lu., J. Wang., B. Ma. (2002). "Friction and wear characteristics of hot-extruded leaded aluminum bearing alloys". *ASM International of JMEPEG*, 11, pp 433-443.
3. J. Bienias, M. Walczak, B. Surowska, J. Sobczaka. (2003). "Microstructure and corrosion behavior of aluminum fly ash composites". April 11, 2003; accepted May 8, 2003, pp. 493-494.
4. Kwiecin'skaa, B. Petersenb, H.I. (2003). "Graphite, semi-graphite, natural coke, and natural char classification—ICCP system". Received 18 August 2003; received in revised form 19 September 2003; accepted 23 September 2003, pp. 100-110.
5. G.Abouelmagd. (2004). "Hot deformation and wear resistance of p/m aluminum metal matrix

- composites”. *Journal of Materials Processing Technology*, 155–156, pp 1395–1401.
6. Ahlatci, H, Candan, E, Cimenoglu, H. (2004). “Abrasive wear and mechanical properties of Al-Si/SiC composites”, *Wear*257, pp. 625-632.
  7. Basavarajappa, S., Chandramohan, G, Dinesh, A. (2004). “Mechanical properties of MMC’s - An experimental investigation”, *Int. symposium of research on Materials and Engineering, IIT, Madras, December 20*, pp. 1-8.
  8. Charles, S., Arunachalam, V.P. (2004), “Property analysis and Mathematical modeling of machining properties of aluminium alloy hybrid (Al-alloy/SiC/fly ash) composites Produced by liquid metallurgy and powder metallurgy techniques”, *Indian Journal of Engg. & Material Science*, 11, pp. 473-480.
  9. Miracle, D.B. (2005). “Metal Matrix composites-From science to technological significance”, *Composites Science and Technology*, 65, pp. 2526-2540.