

Image Processing Based Notice Board Reader Using Raspberry Pi

*Snehal S. Shinde¹, Gayatri V. Savairam¹, Chinmayi S. Vaidya¹, Ashwini S. Koshti¹,
Mr. Sachin Gurav²*

¹Student, Department of Electronics & Telecommunication Engineering, Sharad Institute of Technology, College of Engineering, Yadrav, Maharashtra, India

²Assistant Professor, Department of Electronics & Telecommunication Engineering, Sharad Institute of Technology, College of Engineering, Yadrav, Maharashtra, India

Email: snehalshinde25200@gmail.com

DOI: <http://doi.org/10.5281/zenodo.2633431>

Abstract

The main intention behind this paper is to reduce the “Manpower”; hence we are developing a open source audio notice software – A notice board reader with raspberry pi controls. The image processing is used in the proposed system as Image processing is the process of performing mathematical functions and operations of an image. So, this paper presents the implementation of image processing operations on Raspberry Pi. Raspberry Pi features a Broadcom system on a chip (SOC) which includes ARM compatible CPU. This platform is mainly based on python. Most of the access technology tools built for notice board they are built on the two basic building blocks of OCR software and Text-to-Speech (TTS) system. In this paper captured images are converted into the text through the use of OCR and the text files are processed by an open CV library and using E-speak command audio output is achieved.

Keywords: *Optical Character Recognition (OCR), Text to Speech, Image Processing, E-speak Software, Open CV, Pi Camera, LCD Display, Python Programming.*

INTRODUCTION

The framework is on implementing image capturing technique in based on Raspberry Pi board. The proposed fully integrated system has a camera as an input device to feed the printed text document for digitization and the scanned document is processed by a software module the OCR (optical character recognition engine)[1] A methodology is implemented to recognition sequence of characters and the line of reading. As part of the software development the Open CV (Open source Computer Vision) libraries is utilized to do image capture of text, to do the character recognition. When the camera takes the snapshot of the paper, it is ensured that there is a good lighting condition. The content on the paper should be written in English (preferably Times New Roman) and be of good font size (preferably 24 or more as per MS Word). In this way Raspberry Pi Based Notice Board Reader

for helps a person to read a paper without the help of any human reader or without the help of tactile writing system.

FUNCTIONAL DIAGRAM OF THE PROPOSED SYSTEM

The figure depicted in the figure number1 illustrates the block diagram of proposed method. The raspberry pi is a single board computer which has many features. The power supply is given to the 5V micro USB connector of raspberry pi through the Switched Mode Power Supply (SMPS). The SMPS converts the 230V AC supply to 5V DC. The Pi camera is connected to the CSI port of raspberry pi. The raspberry pi has an operating system named as RASPBIAN which process the conversions. The audio output is taken from the audio jack of the raspberry pi. The converted speech output is amplified using an audio amplifier. The Internet is connected through the Ethernet port in

raspberry pi. The page to be read is placed on a base and the camera is focused to capture the image.

The captured image is processed by the OCR software installed in raspberry pi. The captured image is converted to text by

the software. The text is converted into speech by the TTS library. The final output is given to the audio amplifier from which it is connected to the speaker. Speaker can also be replaced by a headphone for a convenience.

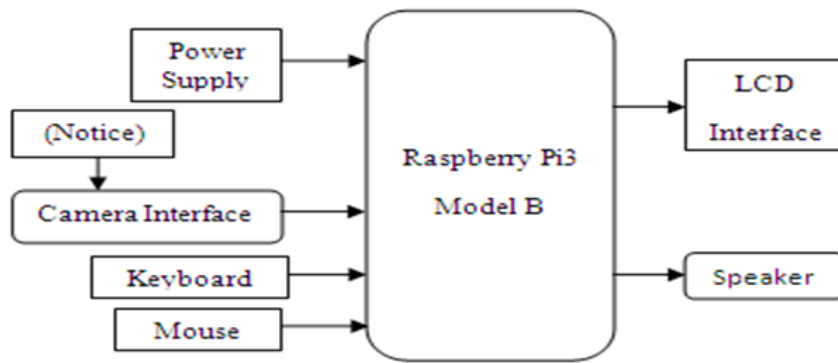

Figure 1: Block Diagram of Notice Board Reader Using Raspberry Pi

IMPLEMENTATION METHODOLOGY

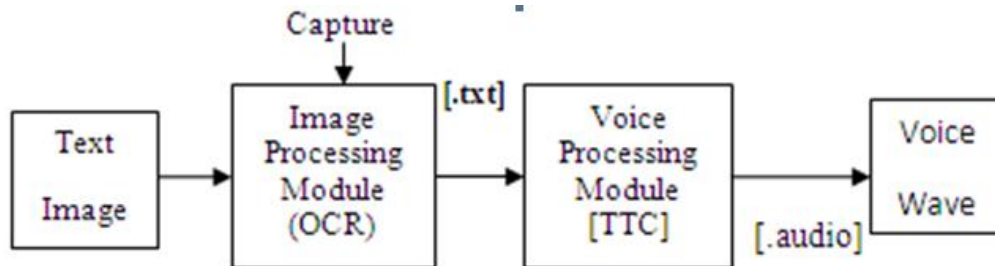

Figure 2: Block Diagram of Text-to-Speech Device

Image to text converter is a type of software used to convert images and documents into text format. Many organizations uses image to text converter to convert their paper documents into electronic files.

TEXT- TO-SPEECH

In text to speech device uses two main modules, first one is the image processing module and second is the voice processing module (figure 2). In image processing module captures image using camera and then converting to text. In voice processing module converts text into sound and processes it with specific physical characteristics so, that sound can be clearly

understood.

a) Image processing Module using OCR. OCR (Optical Character Recognition) also called Optical Character Reader is a system that provides a full alphanumeric recognition of printed or handwritten characters at electronic speed by simply scanning the form. First camera is captured the image and fed to the OCR. Before feeding image to the OCR, it is converted to a binary image to increase the recognition accuracy [6]. Image binary conversion is done by using Image magick software, which is another open source tool for image manipulation. The output of OCR is the text, which is stored in a file (speech.txt).

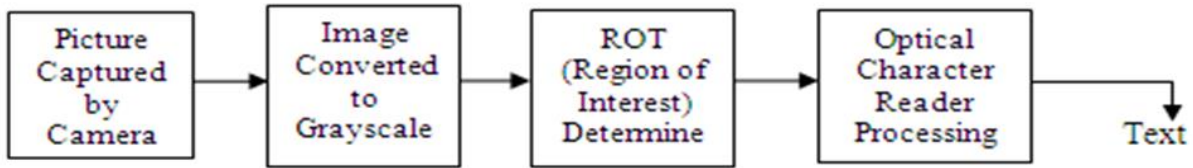

Figure 3: Software Design (Image Processing Module Flow Layout)

Voice Processing Module using TTS

In this module text is converted to speech. The output of OCR is the text, which is stored in a file (speech.txt). Here, Festival software is used to convert the text to speech. Festival is an open source text to speech (TTS) system, which is available in many languages. In this project, English TTS system is used for reading the text.

Hardware Implementation

A] Raspberry Pi

The Raspberry Pi is a low cost, credit-card sized computer that plugs into a computer monitor or TV, and uses a standard keyboard and mouse. Raspbian Is the Operating System of **Raspberry Pi**. Raspberry is a reference to a fruit naming tradition in the old days of microcomputers There's Tangerine Computer Systems, Apricot Computers, and the old British company Acorn, which is a family of fruit. **Pi** is because originally we were going to produce a computer that could only really run Python. The model with the highest specification is the Raspberry Pi 3 Model B, so for many general purpose projects it is widely used. Model B is powerful Pi, with the fastest clock speed, the good RAM, and best feature set.



Figure 4: Diagram of Raspberry pi

Specifications

- Quad Core 1.2GHz Broadcom BCM2837 64bit CPU

- 1GB RAM
- BCM43438 wireless LAN and Bluetooth Low Energy (BLE) on board
- 100 Base Ethernet
- 4 USB 2 ports
- 4 Pole stereo output and composite video port
- Full size HDMI
- CSI camera port for connecting a Raspberry Pi camera
- DSI display port for connecting a Raspberry Pi touch screen display
- Micro SD port for loading your operating system and storing data
- Upgraded switched Micro USB power source up to 2.5A

B] Power Supply:-As shown in figure, the steps down transformer are used to convert 230V AC into 12V DC supply. This 12V DC supply is applied to the rectifier. We can use bridge rectifier for rectification purpose. In bridge rectifier 4 diodes namely D1, D2, D3, D4 are connected in bridge structure. Rectifier converts the alternating input signals to a pulsating direct current. Output of rectifier is given to filter section. In filter section we can use the C filter to remove AC ripple. Output of filter is given to regulator. In that we have to use series of 7805 and 7905. As per our requirement we get constant DC voltage at output.

C] Pi Camera



Figure 5: Diagram of Pi Camera

Pi Camera module is a camera which can be used to take pictures and high definition video. We have used Pi camera v1.3. Raspberry Pi Board has CSI (Camera Serial Interface) interface to which we can attach Pi Camera module directly. This Pi Camera module can attach to the Raspberry Pi's CSI port using 15-pin ribbon cable.

Specification of Pi Camera

- Resolution – 5 MP
- HD Video recording – 1080p @30fps, 720p @60fps, 960p @45fps and so on.
- It Can capture wide, still (motionless) images of resolution 2592x1944 pixels
- CSI Interface enabled.

D] Software Implementation

Operating system: Raspbian

Language: Python3.7.2

Platform: Tesseract, OpenCV (Linux-library)

Tools: OCR engine, TTS engine

Flow Chart

Fist we can capture the image by using Pi camera which can be interfacing with Raspberry Pi. Then this captured image is given to raspberry pi. In Raspberry Pi Input Image is converted into text by using image processing module like OCR using TESSERACT library this image is save by. text extension. After that this text file is given to voice module and using TTS library we can covert text file into speech and save by. audio extension. Then speaker can announcing notice in all classrooms.

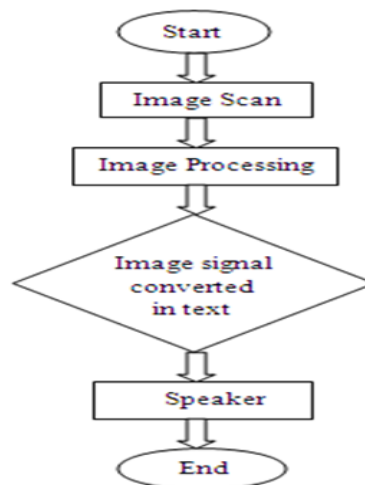

Figure 6: flow chart

RESULT



CONCLUSION

In this analysis, one's we got represent to scan written test and handheld objects for helping the Schools or offices related to notice. OCR is employed to perform word recognition on the localized text regions and rework into audio output. During this analysis, the camera [3] acts as input for the paper. Because the Raspberry Pi board is high-powered the camera starts streaming. The streaming knowledge are going to be displayed on the screen.

REFERENCES

1. K Nirmala Kumari, Meghana Reddy J "Image Text to Speech Conversion Using OCR Technique in Raspberry Pi" International Journal of Advanced Research in Electrical, Electronics and Instrumentation Engineering Vol. 5, Issue 5, May 2016.
2. Mr. Mandar Sujit Jadhav¹, Mr. Sandip Mahasiddha Koli², Mr. Shardul Sharad Kulkarni³ Mr. Shaikh Md Saqlain S. Akhtar⁴, Mr. H.D. Ingle⁵ Raspberry Pi Based Reader for Blind International Journal of Innovative and Emerging Research in Engineering. Volume 5, Issue 1, 2018.
3. Sharan kumar, D.Jayadevappa, Mamata V Shetty "A Novel approach for Segmentation and Classification of brain MR Images using Cluster Deformable Based Fusion Approach" in Periodicals of Engineering and Natural Sciences, Volume 6, Issue no: 2 PP: 237-242 (2018)
4. Anush Goel¹, Akash Sehrawat², Ankush Patil³, Prashant Chougule⁴,

Supriya Khatavkar⁵ Raspberry Pi Based Reader for Blind People International Research Journal of Engineering and Technology (IRJET) Volume: 05 Issue: 06 | June-2018.

5. Aaron James S1 *, Sanjana S2, Monisha M3 OCR based automatic book reader for the visually impaired using Raspberry PI International Journal of Innovative Research in Computer and Communication Engineering Vol. 4, Issue 7, January 2016.
6. Sharan kumar, D.Jayadevappa, Mamata V Shetty "Fuzzy Deformable Based Fusion Approach for Tumor Segmentation and Classification in Brain MRI Images" in International Journal of Engineering & Technology(UAE), Science Publishing Corporation Inc, Vol7 No 4.7, 2018. PP: 171-179.
7. K.S.Shilpashree¹, Lokesha.H², Hadimani Shivkumar³ Implementation of Image Processing on Raspberry Pi International Journal of Advanced Research in Computer and Communication Engineering Vol. 4, Issue 5, May 2015.

Cite this Article as:

Snehal S. Shinde, Gayatri V. Savairam, Chinmayi S. Vaidya, Ashwini S. Koshti, & Mr. Sachin Gurav. (2019). Image Processing Based Notice Board Reader Using Raspberry Pi. Journal of Analog and Digital Communications, 4(2), 1–5. <http://doi.org/10.5281/zenodo.2633433>