

Smart Automation By Using Zigbee and GSM

Mr. Gundhar Chougule^{1*}, Mr. Rohan Soutale², Mr. Uday Deshapande², Mr. Saurabh Dubal², Mr. Sarafraj Sutar², Mr. Sanjay Yedage²

¹Assistant professor, Department of Electrical Engineering, Sharad Institute of Technology College of Engineering, Yadrav, Maharashtra, India

²BE Student, Department of Electrical Engineering, Sharad Institute of Technology College of Engineering, Yadrav, Maharashtra, India

*Email: gundharchougule@sitcoe.org.in

DOI: <http://doi.org/10.5281/zenodo.2620956>

Abstract

This paper includes automation of electrical devices based upon the presence of an occupant. The number of persons going in and out of a room or lab is counted using a counting mechanism. The network is created using Zigbee transceivers. In every room, a Zigbee transceiver known as an end device. The computer has a GUI interface for the users to control the devices and also to monitor the status of the devices. For providing remote access to the user a GSM modem interfaces with the central computer or PC. This paper shows the design and implementation of a novel low-power, low-cost and hand-held wireless device called a SensePod. SensePods can be used by a consumer to interact with a smart home or room using simple gestures like rubbing, tapping or rolling the device on any home surface like a dining table. The device is smaller and forms an ad-hoc wireless network using the ZigBee protocol, and it can be easily interfaced to existing home management systems using a Universal Serial Bus (USB) port.

Keywords: Zigbee module, GSM module, Arduino mega.

INTRODUCTION

Automation of the surrounding environment (building, home) of a modern human being allows increasing his work efficiency and comfort. The significant development in the area of an individual's routine tasks and those can be automated [1]. It also provides a remote interface to appliances. Lab automation can be defined as a system implemented at a residential place or industry whereby the intention is to make the place intelligent so that energy is conserved and security is maintained [2]. The communication between the cell phone and Zigbee is connected to the wireless Arduino board [3]. It provides a user-friendly interface on the host side. The devices can be easily monitored and controlled. Nowadays, we can find most of

the people mostly using their mobile phones and smart devices throughout the day, Hence with the help of this mobile phone, Some daily household tasks can be accomplished by the personal use of the mobile phone. In our paper, we use both Zigbee and GSM to control the appliances [4-6]. Due to this wireless technology, there are several connections are introduced like Zigbee and, GSM. The connection has their unique specifications and applications. Among the two wireless connections, Also most of the current laptop or cell phones have come with a built-in adapter. through GSM, the user can effectively control and monitor the appliances from mobile places by sending SMS. The concept is receiving the sent SMS and processing it further as required

to perform several operations. This type of operation to be performed depends on the GSM network for SMS sent [7].

Zigbee

Using ZigBee-based on pc or laptop controllers for smart automation of wireless network for automation was proposed many years ago. Smart home energy management systems based on the ZigBee protocol have also been implemented. ZigBee has also been proposed for home-monitoring. ZigBee is generic in commercial home automation systems today. Most such systems support smart hubs that deploy heterogeneous wireless communications including ZigBee, Wi-Fi, and ZWave, etc. ZigBee is typically used to communicate between switches or appliances, while Wi-Fi is used to connect to the Internet, or with hand-held mobile phones and laptops. For smart homes, ZigBee has also been integrated with other home management protocols like Digital Addressable Lighting Interface. ZigBee has also been used extensively in specialized smart applications that cater to the elderly. For example, Clarke et al. have implemented a monitoring system for weak and elderly based on the ZigBee health care profile. ZigBee-based devices using tri-axial accelerometers have also been used to detect falls in the elderly. Similarly, Chen et al. present a reliable ZigBee-based monitoring system that not only detects falls but also reports the position of a person and their ECG signals [8]. Binary sensors on the ZigBee network have also been used to detect the early onset of dementia by detecting forgetting behaviors. Finally, Tung et al. have implemented a ZigBee gateway to remotely monitor patients.

GSM

GSM networks are used with cell phones, connecting the devices to cellular service. The cellular network is assigned a unique code or codes, called the MCC/MNC, which identifies the phone to that specific GSM network. T-Mobile is among the U.S. providers to use MCC/MNC numbers. GSM digitizes and compresses data and then sends it down a channel with two other streams of user data, each in its own time slot. It operates at the 900 MHz or 1800 MHz frequency band. The maximum distance the GSM specification supports in practical use is 35 kilometers. This modem can be interfaced with a Microcontroller using USART (Universal Synchronous Asynchronous Receiver and Transmitter) feature (serial communication) [9].

LITERATURE SURVEY

Smart home automation system using Zigbee in this paper is carried out by. M. Han and J. H. Lim [1] using Zigbee and GSM module. due to the wireless technology, there are several connections are introduced like GSM and Zigbee. Among the two wireless connections, Zigbee is chosen with its suitable ability to control appliances from indoor and GSM. Towards Smart automation control electrical devices online"- M. Abou El-Ela, [4]. The web-based controller is developed for controlling electrical devices. In this method, a Web tool is used to control all electronic appliances. The software is designed for the interface between user and Web browser Using internet access, the user can monitor and control appliances. This system is not so effective because it does not use mobile technology.

CIRCUIT DESIGN

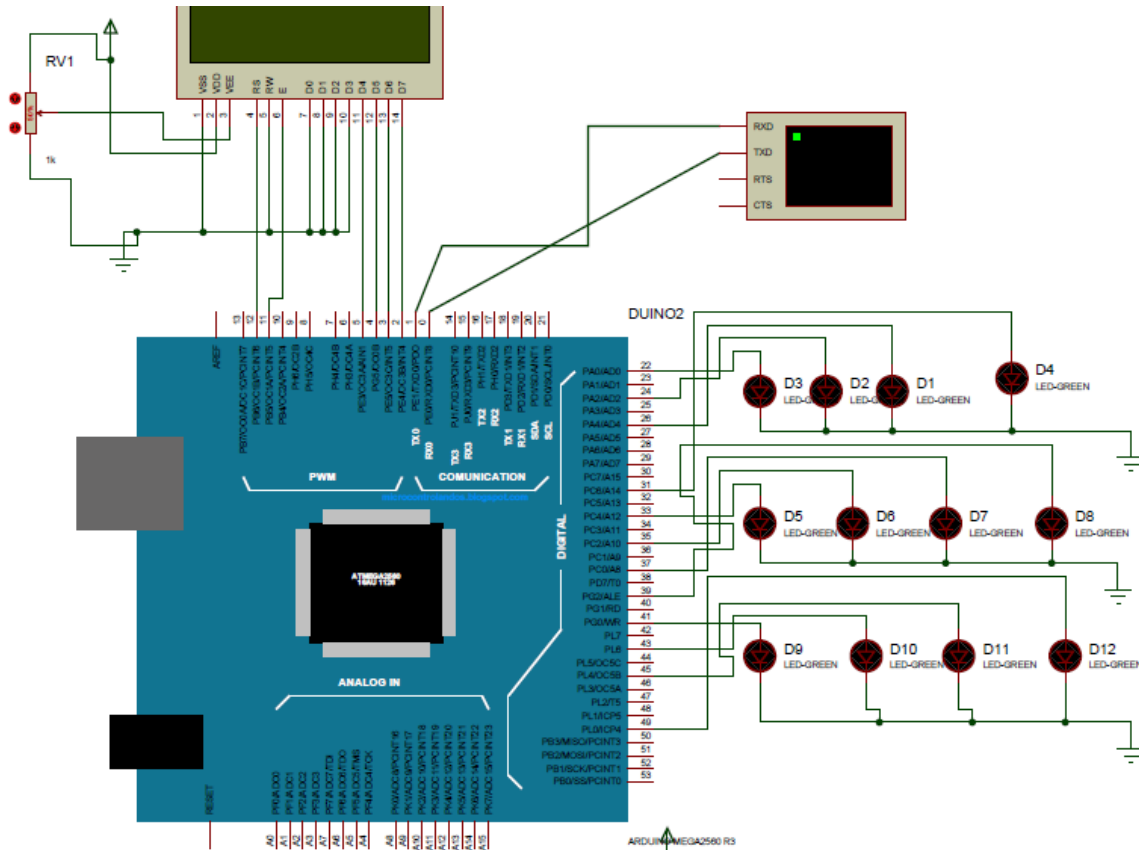

Figure 1: Circuit Design

As shown in figure 1, this system consists of a 16x2 LCD module is used for displaying the status of home appliances which is directly connected to Arduino in 4-bit mode. Data pins of LCD by indicated as RS,EN,D4,D5,D6,D7 are connected to Arduino digital pin number 7,6,5,4,3,2.For sending commands to Arduino from laptop or PC we use the USB cable that we used for uploading the program into Arduino And relay driver IC ULN2003 is also used for driving relays.250, 7amp 4 relays are used for controlling light, fan, motor and PC and relays are connected to Arduino pins through relay driver IC for controlling light, fan, and PC respectively. Here serial communication is used to control the lab appliances. We send commands like a light on, light off, fan on; fan off to control Ac home appliances. After receiving the given commands, Arduino sends the signal to relays which are responsible for switching on or off the appliances. When we press

ENTER after typing one of any given command on the hyper terminal or serial terminal Arduino performs the relative task like turning on the "Fan" and likewise another task. And the relevant message is also displayed on16*2 LCD which is programmed in the code.

BLOCK DIAGRAM OF PRPOSED SYSTEM

This paper proposes the use of a small wireless system as shown in figure 2. It gives us the perceptible idea of a system which constitutes of an automation system with a GSM and Zigbee module. The heart of the whole system is Arduino. By mobile application controlled lab automation system provides a simpler solution with Android application technology. The whole system is a parallel operation of Zigbee and GSM. The power supply 12 V is given to the Zigbee and GSM as well as Arduino mega. The Arduino Mega 2560 is

a microcontroller board based on the ATmega (Datasheet). It is 54 digital input and output pins, 16 analog inputs, 4 UARTs, a 16 MHz crystal oscillator, a USB connection, a power jack, an ICSP header, and a reset button. It is

everything needed to support the Arduino simply connect it to a computer with the power it with an AC-to-DC adapter or battery to get started. The output of Arduino is given to the relay module to control the parameter.

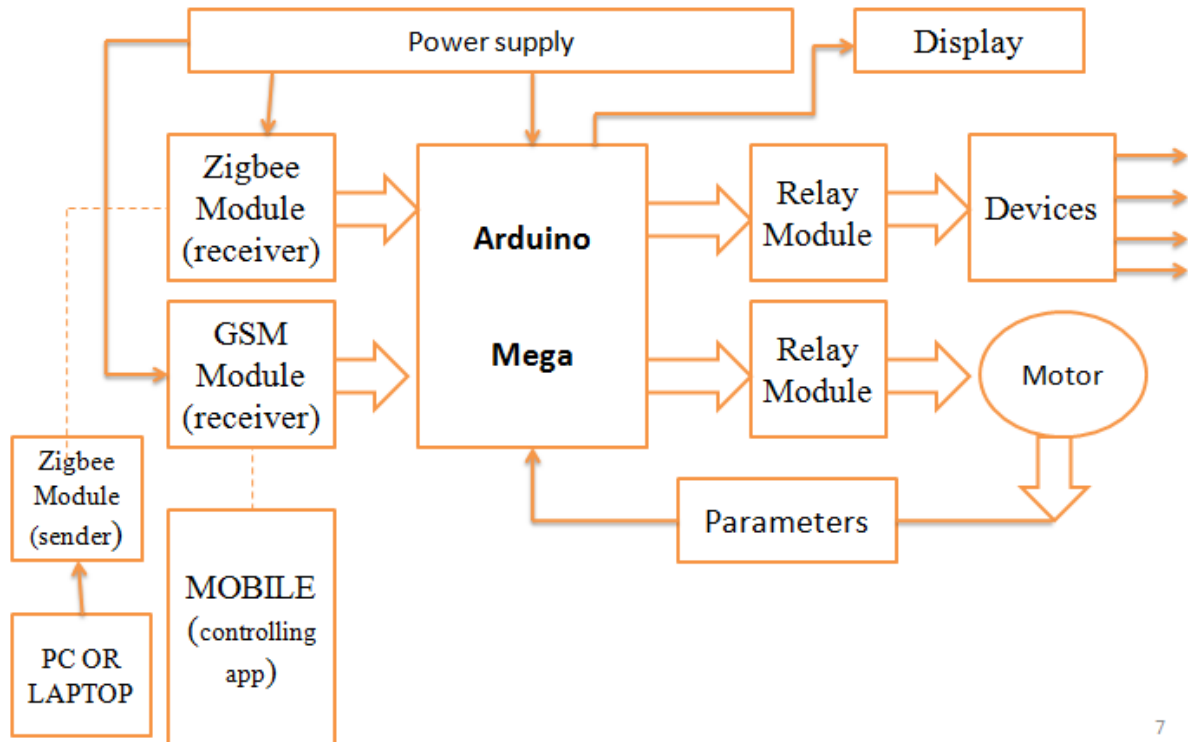

Figure 2: Block Diagram of Proposed System

LOADS

There are many electrical appliances which can be connected to this automation system such as fan, Bulb, PC etc. We are going to use this system to on and off the fan, tube light, and personal computer also. We can switch on or off all the appliances simultaneously also. These appliances can be controlled through an Android application on our mobile phone. In this project for the demo, we can use electrical appliances like fan, bulb etc. In this project, we have used 6 relays to control 6 fans in our lab. Without using any conventional switch we control these fans through our mobile phone from anywhere by using GSM and Bluetooth module. Also, we can control Tube lights and the personal computer through this project.

ANDROID APP INVENTOR

The main concept is paper to a wireless controlling system for houses and labs are controlled because it gives the user a comfortable environment to use home appliances. The one application is developed for suitable of controlling the parameter and all command are send through this application by using GSM technique. Many ways have been used for wireless home and lab automation in the past few years. Some of these existing controlling systems are based on GSM technique are used.

ANDROID APP INVENTOR

This technology has been implemented by advancing the automation are getting smarter. This technology is advancing so house as well as lab are also getting

smarter. Presently, the conventional wall switches located in different parts of the

house makes. It is difficult for the user to go near them to operate.

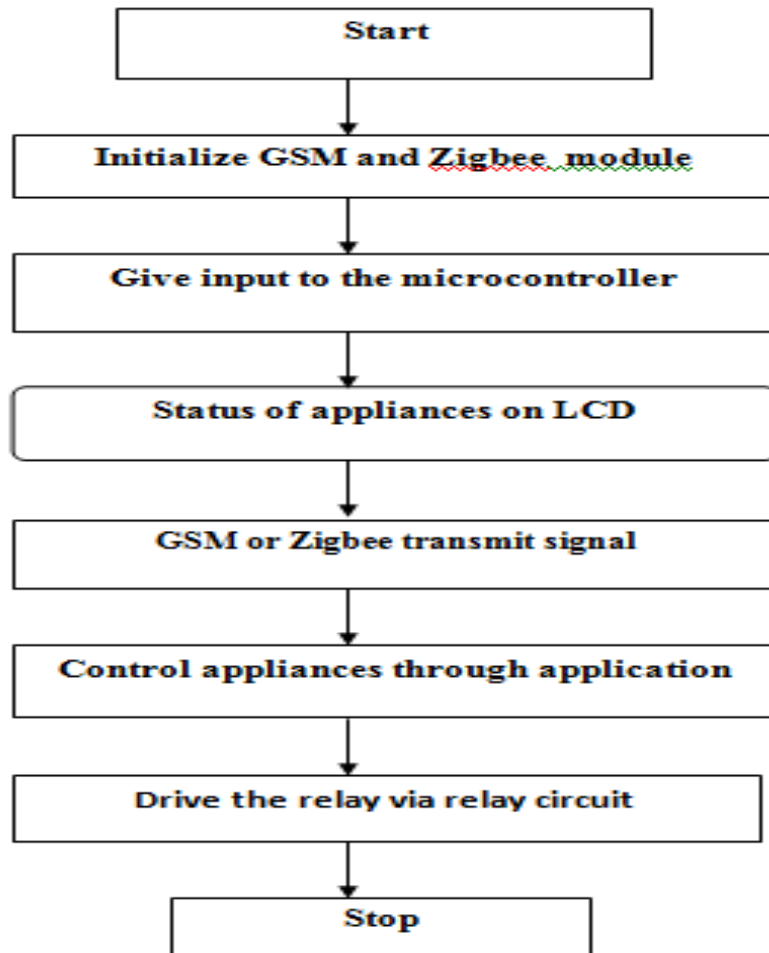

Figure 3: Flow chart

FUTURE SCOPE

The proposed system is useful for expanding the automation of all other appliances, we can remove the limitation for controlling only a few devices. To monitor the activities around the lab, Security cameras can be installed and controlled by the user. The security systems can also include the sensors which are used to detect any kind of unauthorized movement and it will notify the user about that event. For this system, there is no need to carry separate remote or any other controlling devices so it can be used in residential areas.

IMPLEMENTATION

Appliances or devices in a house or lab are connected to the four- channel relay of

Zigbee and GSM board. The relay board consists of four independent relays mounted on a single board. Each relay is connected to one LED, which indicates the status of the appliance connected to it. There are six pins on the board, out of which one is for the power supply (12 V), one for the ground connection, and the remaining four are control pins for each of the four relays. This relay board is interfaced with the microcontroller. The control pins of the relay board are connected to the input and output ports of the microcontroller. The GSM SIM 300 modem and Zigbee module are interfaced to the microcontroller by means of serial communication. The ground pin of SIM 300 is connected to the microcontroller's

ground, and the transmission and receiving pins are connected to the receiving and transmitting pins, respectively, of the microcontroller. The sensor modules, such as the temperature, humidity, and LPG gas sensors, are placed on the same board where the microcontroller is located and connected based on their pin configurations. The power supply is then given to the microcontroller, relay board, and the SIM 300 module. Once the circuit connections are made, a valid SIM card is put in the module and authenticated. The

user's mobile number is verified and set as default for sending SMS. When the user wants to turn on/off an appliance, a message is sent from the user's mobile phone to the number placed in the module. This turns on/off the device through the relay board. In addition to controlling the device, we can also learn the status of each appliance and obtain information about the temperature and humidity. The messages used for communication between the user and the system are summarized.

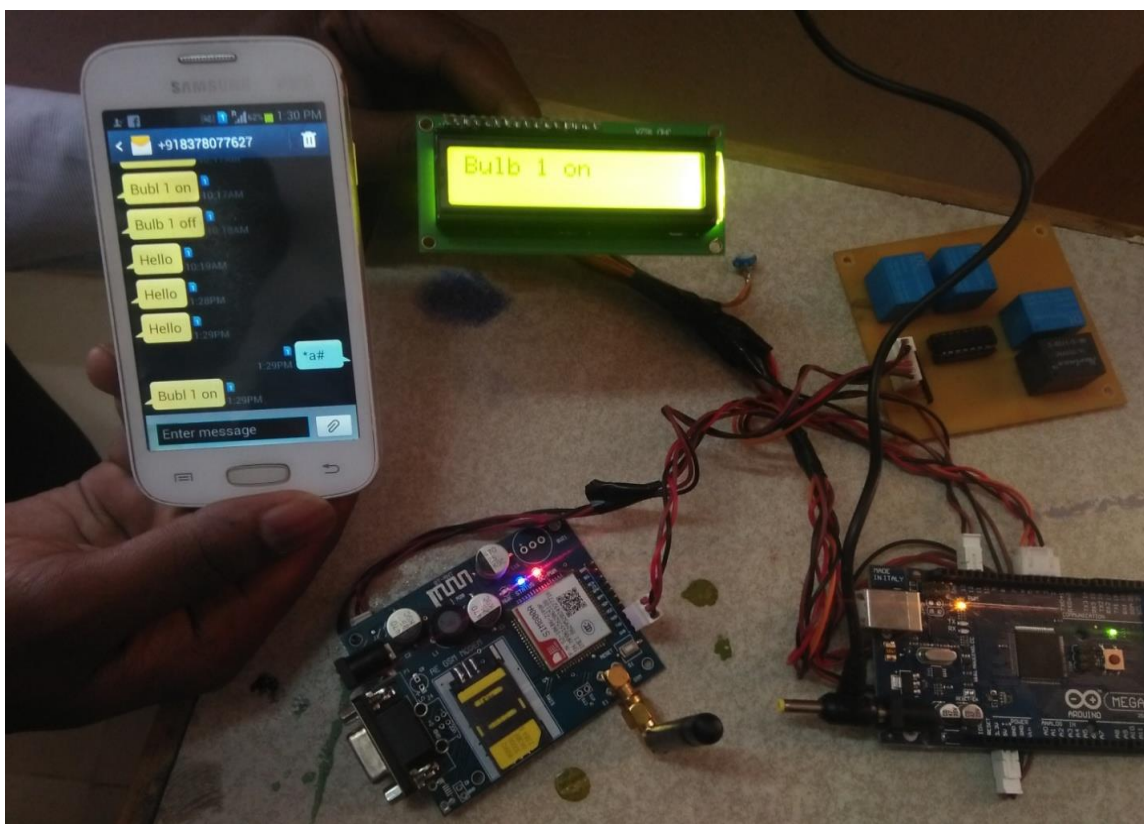

Figure 4: GSM module result

RESULT

The finished project was tested in the lab. The Zigbee and GSM module is placed in the lab and controlling the parameter being tested successfully. The monitoring parameter of devices like the motor is (voltage, current, speed, temperature) by using the Zigbee module are tested successfully. Also using the GSM module control the labor home devices for example bulb ON-OFF command send through mobile tested are successful. The

Zigbee coordinator and GSM module are controlled using the program. The data for these devices has also been tested in a cool term.

CONCLUSION

GSM and Zigbee modules are used for the wireless communication between the base station and remote sensor node. The GSM modules communicate over cellular networks, which means they can communicate over long distances Another

advantage of the system is the low power consumption and low cost. The developed system effectively monitors and controls the electrical appliances at the laboratory. Thus the real-time monitoring of the electrical appliances can be carried out. The system can be extended for monitoring the whole building industry and We provide a solution by which we can lower the consumption and enhance better utilization of already limited resources during peak hours.

REFERENCES

1. D. M. Han and J. H. Lim, "Design and implementation of smart home energy management systems based on ZigBee," *IEEE Transactions*
2. I. A. Zualkernan, A.-R. Al-Ali, M. A. Jabbar, I. Zabalawi, and A. Wasfy, "InfoPods: Zigbee-based remote information monitoring devices for smart-homes," *Consumer Electronics, IEEE Transactions on*, vol. 55, no. 3, pp. 1221–1226, 2009.
3. H. Y. Tung, K. F. Tsang, H. C. Tung, K. T. Chui, and H. R. Chi, "The design of dual radio ZigBee homecare gateway for remote patient monitoring," *IEEE Transactions on Consumer Electronics*, vol. 59, no.4, pp. 756–764, Nov. 2013.
4. M. Abou El-Ela, "GSM network based PLC system", submitted to 2nd International Industrial Engineering Conference, 19-21 Dec, 2004.
5. Y. Sasaki, S. Kagami, H. Mizoguchi, and T. Enomoto, "A predefined command recognition system using a ceiling microphone array in noisy housing environments," in 2008 IEEE/RSJ International Conference on Intelligent Robots and Systems, 2008, pp. 2178–2184.
6. J. Han, E. J. Pauwels, P. M. de Zeeuw, and P. H. N. de With, "Employing an RGB-D sensor for real-time tracking of humans across multiple re-entries in a smart environment," *IEEE Transactions on Consumer Electronics*, vol. 58, no. 2, pp. 255–263, May 2012.
7. P. Bao, A. I. Maqueda, C. R. del-Blanco, and N. García, "Tiny hand gesture recognition without localization via a deep convolutional network," *IEEE Transactions on Consumer Electronics*, vol. 63, no. 3, pp. 251–257, Aug. 2017.
8. O. D. Lara and M. A. Labrador, "A survey on human activity recognition using wearable sensors," *IEEE Communications Surveys Tutorials*, vol. 15, no. 3, pp. 1192–1209, Third 2013.
9. Y. Tawk, J. Constantine, and C. G. Christodoulou, "Cognitive radio and antenna functionalities: A tutorial," *IEEE Antennas Propag. Mag.*, vol. 56, no. 1, pp. 231–243, Feb. 2014.

Cite this Article as:

Mr. Gundhar Chougule, Mr. Rohan Soutale, Mr. Uday Deshapande, Mr. Saurabh Dubal, Mr. Sarafraj Sutar, & Mr. Sanjay Yedage. (2019). Smart Automation By Using Zigbee and GSM. *Journal of Switching Hub*, 4(1), 20–26.
<http://doi.org/10.5281/zenodo.2620956>