

## A Mathematical and Experimental analysis of degradation of lubricating oil in four stroke Motorbikes

**S Bordoloi**

*Head of Department*

*Department of Applied Electronics and Instrumentation,  
GIMT, Guwahati, Assam, India*

**Email:** [sandip\\_aei@gimt-guwahati.ac.in](mailto:sandip_aei@gimt-guwahati.ac.in)

**DOI:** <http://doi.org/10.5281/zenodo.1477198>

### **Abstract**

*This paper presents a mathematical and experimental analysis of degradation of lubricating oil used in four-stroke motor bikes. For mathematical analysis, Debye equation have been related to the dielectric constant and temperature of lubricating oil samples of four stroke motorbikes The instrumentation system used for experimentation consists of (i) a coaxial cylindrical capacitor and a LM35 IC as sensors (ii) A ATmega 32 based microcontroller system for sampling, processing and display of signal. The coaxial cylindrical capacitive sensor and LM35 are used to provide the measure of dielectric constant and temperature of a lubricating oil sample.*

**Keywords:** *Lubricating oil, Debye, dielectric constant, degradation.*

### **INTRODUCTION**

Lubricating oil is employed in internal combustion engines and consists of complex mixtures of hydrocarbons. Due to its viscosity and non-compressible nature, lubricating oil keeps the moving components from contacting with each other. Lubricating oil is also used for resisting shear forces, minimize gear wear, maintain engine cleanliness and control acid corrosion, resist foaming and control rust corrosion. Highly viscous oil has greater internal resistance which increases the engine's temperature.

The viscosity of lubricating oil is identified by its SAE (Society for Automotive Engineers) number. For example, in SAE 10 W oil, the number relates to viscosity at particular temperature while the letter 'W' indicates the oil suitability for colder temperatures [1]. Ambient temperature affects the oil viscosity. With decrease in ambient temperature, oil thickens leading to

pumpability and circulation problems [2].

The density and the dielectric constant are related to the oil viscosity by the Debye equation [3]. Oil viscosity is affected by temperature and this effect is studied by observing the change in electrical conductivity of oil with change in temperature [4].

This paper describes a mathematical analysis of degradation of lubricating oil used in 4-stroke motorbikes using the Debye equation. An experimental approach to the analysis is carried out using a microcontroller based instrumentation system. The system uses coaxial cylindrical capacitor sensor and LM35 IC temperature sensor. An ATmega 32 microcontroller-based system have been used to sample analog signals via a passive low-pass filter (LPF) to determine and display the quality of lubricating oil under investigation.

## THE CAPACITANCE OF COAXIAL CYLINDRICAL CAPACITOR

Lubricating oil is a dielectric material with low dielectric losses. With prolong use the dielectric property of the oil degrades. Contaminated oil may contain mixtures of water, soot particles, acid combustion products, glycol, ferrous and non-ferrous metallic particles. The degraded oils generate more polarized molecules than the weakly polarized large hydrocarbon molecules [5]. The presence of conducting contaminants in the lubricating oil changes the permittivity of the oil which can be detected by a capacitive sensor to measure the amount of degradation of lubricating oils.

The expression for capacitance  $C$  of a coaxial cylindrical capacitor is given as-

$$C = \frac{2\pi\epsilon_0\epsilon_r L}{\ln\frac{R}{r}} F \quad (1)$$

where  $R$  and  $r$  are the outer and inner radii of the cylinders,  $L$  is the length of the coaxial cylinder along its axis,  $\epsilon_0$  and  $\epsilon_r$  are the permittivity of free space and the dielectric medium between the two concentric cylinders. Thus the expression for capacitance can be represented as:

$$C = K_1 \epsilon_r \quad (2)$$

Where 
$$K_1 = \frac{2\pi\epsilon_0 L}{\ln\frac{R}{r}}$$

## RELATION BETWEEN DIELECTRIC CONSTANT, KINEMATIC VISCOSITY AND TEMPERATURE

The dielectric constant ( $\epsilon_r$ ) is related to the polarizability ( $\alpha$ ) and the dipole moment ( $\mu$ ) by the Debye equation [3].

$$\frac{\epsilon_r - 1}{\epsilon_r + 2} = \left( \alpha + \frac{\mu^2}{3KT} \right) \left( \frac{A\rho}{3MW} \right) \quad (3)$$

where,  $\epsilon_r$  is the dielectric constant of oil,  $\alpha$  is the polarizability of oil,  $\mu$  is the dipole moment of oil,  $K$  is the Boltzman constant

$\left( 1.31 \times 10^{-23} \frac{\text{joule}}{^\circ\text{Kelvin}} \right)$ ,  $T$  is the temperature in  $^\circ\text{Kelvin}$ ,  $A$  is the Avogadro's number ( $6.02 \times 10^{23}$  molecules of oil/mole),  $\rho$  is the density of oil ( $\text{gram/cm}^3$ ) and  $M$  is the molar mass of oil ( $\text{gram/mole}$ ).

The dynamic viscosity is expressed by the Vogel equation (viscosity-temperature equation) [6] as-

$$\mu_0 = a \exp\left(\frac{b}{T-c}\right) \quad (4)$$

where  $\mu_0$  is the dynamic viscosity at atmospheric pressure (Pas),  $a$ ,  $b$  and  $c$  are constants,  $T$  is the absolute temperature ( $^\circ\text{K}$ ).

Expanding the exponential term by Taylor series and neglecting the higher order terms it is found that

$$\mu_0 = a \left( 1 + \frac{b}{T-c} \right) \quad (5)$$

Now it is known that

$$\mu_0 = \vartheta_0 \rho \quad (6)$$

where  $\vartheta_0$  is the kinematic viscosity (at the atmospheric pressure) and  $\rho$  is the density.

Combining equation (5) and equation (6), equation (7) is obtained

$$\rho = \frac{a}{\vartheta_0} \left( 1 + \frac{b}{T-c} \right) \quad (7)$$

Substituting the expression of  $\rho$  of equation (7) in equation (3)

$$\frac{\epsilon_r - 1}{\epsilon_r + 2} = \left( \alpha + \frac{\mu^2}{3KT} \right) \left( \frac{A}{3M} \right) \times \frac{a}{\vartheta_0} \left( 1 + \frac{b}{T-c} \right) \quad (8)$$

Since  $A$ ,  $K$ ,  $a$ ,  $b$ ,  $c$  are constants, the dielectric constant is dependent on the temperature ( $T$ ), dipole moment ( $\mu$ ), polarizability ( $\alpha$ ) and kinematic viscosity ( $\vartheta_0$ ) of the sample. Taking  $K_2 = \frac{Aa}{3} \left( 1 + \frac{b}{T-c} \right)$

$$\frac{\epsilon_r - 1}{\epsilon_r + 2} = \left[ \alpha + \frac{\mu^2}{3KT} \right] \left( \frac{K_2}{M \times \vartheta_0} \right) \quad (9)$$

Solving the above equation gives

$$\epsilon_r = \frac{1 + 2 \frac{K_2}{M \times \vartheta} \left( \alpha + \frac{\mu^2}{3KT} \right)}{1 - \frac{K_2}{M \times \vartheta} \left( \alpha + \frac{\mu^2}{3KT} \right)} = \frac{1 + 2x}{1 - x} \quad (10)$$

where  $x = \frac{K_2}{M \times \vartheta} \left( \alpha + \frac{\mu^2}{3KT} \right)$

Hence,  $\epsilon_r = \frac{1 + 2x}{1 - x} \quad (11)$

$\frac{1}{1-x}$  can be expanded using the Taylor series if  $x < 1$  and then multiplied with  $1 + 2x$

Therefore to determine a possible value of  $x$ , the following values are taken for hydraulic oil (HM 32) and HVL-46 which are also lubricating oil [6]

**Table: 1.** Determining a possible value of  $x$ , the following values are taken for hydraulic oil (HM 32) and HVL-46

Oil	Kinematic viscosity	Temp	$a$	$b$	$c$	$\alpha$ (considered for carbon molecule)	$\mu$ (=1 Debye)	Molar mass $M$ (27pprox.)	Calculated value of $x$
HM32	80.13mm <sup>2</sup> /sec	293.5°K	0.0000736317	797.7122	177.3652	11 × 1.64878 × 10 <sup>-41</sup>	1 × 3.335 × 10 <sup>-41</sup>	200gm/mole	1.1314 × 10 <sup>-15</sup>
HVL 46	146.92 mm <sup>2</sup> /sec	293.5°K	0.000116198	799.7249	176.7128	11 × 1.64878 × 10 <sup>-41</sup>	1 × 3.335 × 10 <sup>-41</sup>	250 gm/mole	9.028 × 10 <sup>-17</sup>

The value of  $x$  is calculated to be  $\epsilon_r = 1 + 3x + 3x^2 + 3x^3 + \dots + 3x^n \quad (12)$

The higher order terms of  $x$  can be neglected since  $x \ll 1$ . So  $\epsilon_r = 1 + 3x$   
Substituting the value of  $x$ ,

$$\epsilon_r = 1 + 3 \frac{K_2}{M \times \vartheta} \left( \alpha + \frac{\mu^2}{3KT} \right) \quad (13)$$

Thus the dielectric constant of lubricating oil is a function of the molecular weight ( $M$ ), temperature ( $T$ ), dipole moment ( $\mu$ ), polarizability ( $\alpha$ ) and kinematic viscosity ( $\vartheta_0$ ) of the sample.

**DESCRIPTION OF THE CO-AXIAL CYLINDRICAL CAPACITIVE SENSOR**

The coaxial cylindrical capacitor was constructed by taking two concentric steel

cylinders as shown in Figure-1. The outer and the inner radii of the cylinders of the coaxial capacitor are  $R=2.7\text{cm}$  and  $r=1.7\text{cm}$  respectively. The length of each cylinder,  $L=8.8\text{cm}$ . The two cylinders are firmly suspended from a circular wooden plate at three points placed at an angle of  $120^\circ$  apart along the circumference using fine steel wires. This arrangement allows the two cylinders to remain suspended to the wooden plate maintaining a fixed gap between them. Flexible wires for electrical connections are attached to the two cylinders. One capacitor ( $C_f$ ) of fixed value is connected in series to form a potential divider circuit. Another capacitor ( $C_{pa}$ ) of fixed value is connected in parallel to the coaxial capacitive sensor as shown in figure-1.

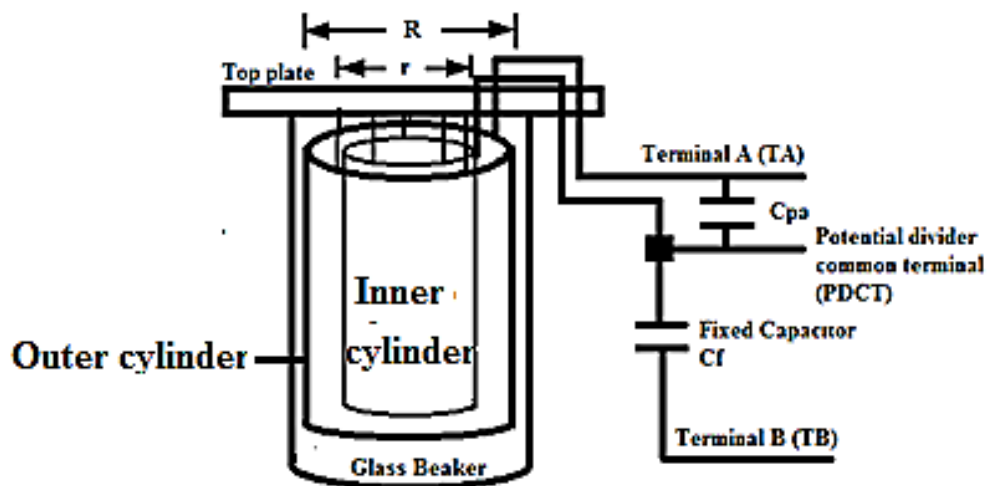
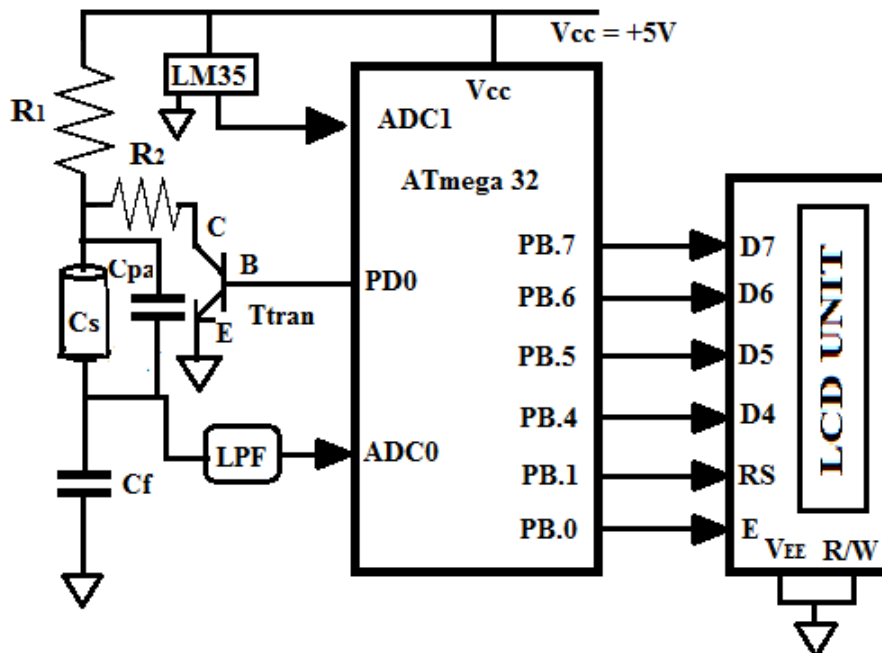

*Fig: 1. Geometrical configuration of the series coaxial cylindrical capacitor*

**CAPACITIVE POTENTIAL DIVIDER  
CIRCUIT WITH  
MICROCONTROLLER SYSTEM**

The potential divider circuit has a discharging static switch in the form of a transistor ( $T_{tran}$ ). A stable 5 volt source is connected to the capacitors of the coaxial capacitive sensor through a series

resistance  $R_1$ . Terminal TA is connected to a collector C terminal of a transistor  $T_{tran}$ . The emitter is connected to the ground and the base (B) terminal of the transistor is connected to the PD0 pin of ATmega 32 microcontroller. The configuration is shown in figure-2.



*Fig:2. The potential divider circuit with microcontroller system*

The coaxial cylindrical capacitor containing samples of lubricating oil is denoted as  $C_s$ , a fixed value capacitor ( $C_{pa}$ ) is connected in parallel to the coaxial

cylindrical capacitor. Another fixed value capacitor ( $C_f$ ) is connected in series to the parallel combination of  $C_s$  and  $C_{pa}$  forms a part of the potential divider circuit. The

potential divider common terminal (PDCT) is interfaced to ADC<sub>0</sub> (pin number 1, analog channel-0) of microcontroller Atmega32 via a passive LPF circuit whose cut-off frequency  $f_c = 1.6\text{Hz}$  ( $f_c = \frac{1}{2\pi \times 10\text{k}\Omega \times 10\mu\text{F}}$ ). The output voltage across the capacitor  $C_f$  (during charging) is given by

$$V_{out(s)} = \frac{C_s + C_{pa}}{C_s + C_{pa} + C_f} \times (V_{cc} - IR_1) \quad (14)$$

where  $IR_1$  represent the drop across resistor  $R_1$  and  $I$  is the current.

Rearranging equation -15 gives

$$V_{out(s)} = \frac{1}{1 + \frac{C_f}{C_s + C_{pa}}} \times (V_{cc} - IR_1) \quad (15)$$

Substituting equation (1) in (16),  $V_{out(s)}$  is expressed as-

$$V_{out(s)} = \frac{1}{1 + \frac{\frac{2\pi\epsilon_0\epsilon_r L}{\ln r}}{R} + C_{pa}} \times (V_{cc} - IR_1) \quad (16)$$

Equation (17) shows that  $V_{out(s)}$  depends on the term  $\epsilon_r$  ( $= 1 + 3 \frac{K_2}{M_s \times \vartheta_s} (\alpha_s + \frac{\mu_s^2}{3KT})$ ),

since the other terms are constants.  $V_{out(s)}$  is therefore dependent on kinematic viscosity and temperature. Since viscosity of a liquid is dependent on temperature, change in temperature will affect the viscosity and hence the dielectric constant  $\epsilon_s$  of the liquid. Hence, a variation of temperature and  $V_{out(s)}$  will help in estimation of degradation of lube oil.

The coaxial cylindrical capacitor is discharged through resistance  $R_2$ . For this purpose, PD0 has to be kept in state '1' to operate the transistor  $T_{tran}$  in saturation state for a fixed discharging time. The time required to discharge the coaxial cylindrical capacitive sensor is given as-

$$T_{dis} = -R_2 C_{EQ} \ln \frac{V_{dis}}{V_{cc}} \quad (17)$$

where  $C_{EQ} = \frac{(C_s + C_{pa}) \times C_f}{C_s + C_{pa} + C_f}$

Now taking  $V_{dis}$  as 10% of  $V_{cc}$ , we have-  
 $T_{dis} = -R_2 C_{EQ} \ln(0.1) = 2.3026 R_2 C_{EQ}$  (18)

Similarly, the coaxial cylindrical capacitive sensor has to be charged through resistance  $R_1$  before reading the sensor output. For this purpose, PD has to be kept in state '0' to operate the transistor  $T_{tran}$  in cut-off state for a fixed charging time. The time required to charge the coaxial cylindrical capacitive sensor is given as-

$$T_{ch} = -R_1 C_{EQ} \ln \frac{V_{cc} - V_{ch}}{V_{cc}} \quad (19)$$

Taking  $V_{dis}$  as 90% of  $V_{cc}$ , we have-

$$T_{ch} = -R_1 C_{EQ} \ln(0.1) = 2.3026 R_1 C_{EQ} \quad (20)$$

If pure lube oil sample ( $\epsilon_r = 2.1$ ) is used as the dielectric medium in the coaxial cylindrical capacitive sensor, then for the given dimension,  $C_s = 22.22\text{pF}$ . Taking the values  $C_{pa} = C_f = 2200\text{pF}$ , it is found that  $C_{EQ} = 1.105\text{nF}$ , where  $C_s$  is the capacitance of the coaxial cylindrical capacitors when a pure sample is used as dielectric medium.

Taking  $R_1 = R_2 = 10\text{M}$ ,  $T_{dis} = T_{ch} = 25\text{mSec}$ .

To ensure proper charging and discharging time, the practical charging and discharging time will be taken as three times that of the calculated value.

Thus  $T_{dis}(Prac) = T_{ch}(Prac) = 3 \times T_{dis} (= T_{ch}) = 3 \times 25\text{msec} = 75\text{msec}$

This charging and discharging time is set by the Atmega32 microcontroller. The microcontroller reads the analog voltage ( $V_{out(s)}$ ) from the coaxial capacitive potential divider sensor circuit and voltage ( $V_t$ ) from LM35 IC temperature sensor through its ADC<sub>0</sub> channel (pin number 1, analog channel-0) via a LPF and ADC<sub>1</sub> channel (pin number 2, analog channel-1) respectively. The display unit of the microcontroller system consists of 16×2 (i.e. two rows having 16 character LCD display) LCD display units.

It is interfaced to PORT-B of Atmega32 for display control. LSB of port D (i.e. PD0) is interfaced to the base of transistor  $T_{tran}$ . It is used for the purpose of discharging the coaxial capacitive potential divider sensor.

### EXPERIMENTAL PROCEDURE AND RESULTS

The amount of degradation of lubricating oil of a vehicle is largely dependent on its run time or Distance of Travel (DoT) in kilometer. More the distance travelled by a vehicle, more would be the degradation of its lube oil. Under running condition, the temperature of lubricating oil of a vehicle is used to be higher than ambient temperature. Therefore, for on-line monitoring of lubricating oil of a vehicle, both the temperature and measure of dielectric constant provided by equation (18) are required. For the purpose of experimentation, lubricant oil samples of a Hero Glamour four-stroke engine bike with several run time were collected. The lubricating oil used for the experiment is Hero Glamour four-stroke engine bike of grade 10W-30 SJ synthetic engine oil. During experimentation process, each sample was taken in a 200 mL glass beaker.

The experimental procedure adopted for measuring the output of capacitive potential divider circuit ( $V_{out(s)}$ ) and voltage of LM35 IC requires the following steps-

1. The coaxial cylinders are cleaned thoroughly and allowed to dry.
2. PD0 is loaded with status '1' to operate the transistor  $T_{tran}$  in saturation state for 75ms and then loaded with status '0' to operate the transistor  $T_{tran}$  in cut-off state. It is done to discharge the capacitors.
3. The coaxial cylindrical capacitive sensor is immersed in a lubricating oil sample.
4. The lubricating oil sample is heated from 30°C to 100°C using an electric heater connected to a auto-transformer.
5. The microcontroller based system samples the values of  $V_{out(s)}$  and LM35.
6. Steps I – vis repeated with lubricating oil samples having different DoT.

The variation of Temperature (of sensor LM35) and  $V_{out(s)}$  for lubricating oil sample with different DoT are plotted in MATLAB and is shown in Figure-3. The output voltage of temperature sensor LM35 is converted to temperature using the scale factor [7]  $1^{\circ}\text{C}=10\text{mV}$

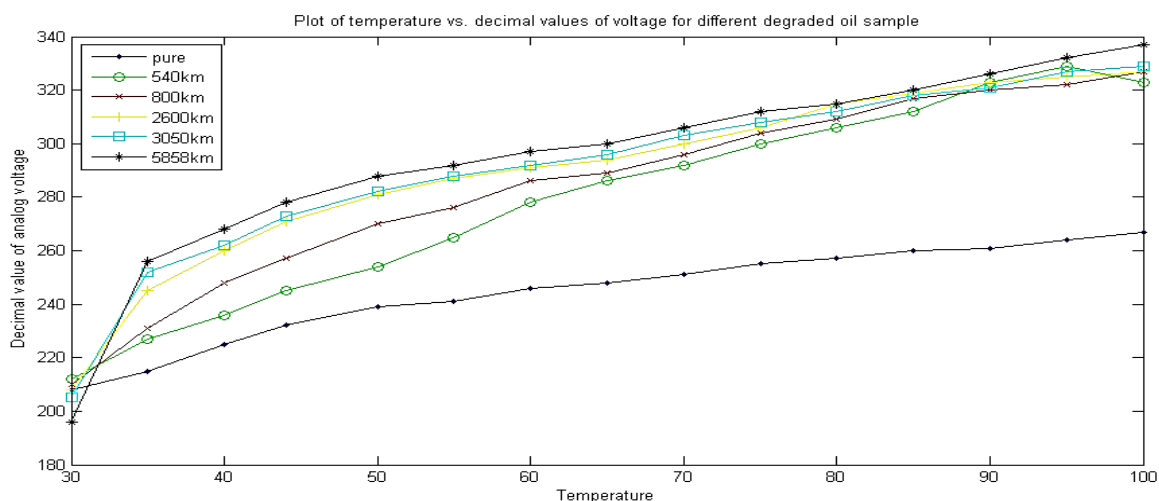

**Fig.3.** Plot of variation of Temperature and  $V_{out(s)}$  for lubricating oil sample with different DoT

Since the curves for different DoT are overlapping each other at higher temperatures, the curves are smoothened using curve fitting technique (using

2<sup>nd</sup> order polynomial) in MATLAB software. The fitted curves of Temperature v.s.  $V_{out(s)}$  is shown in figure 4.

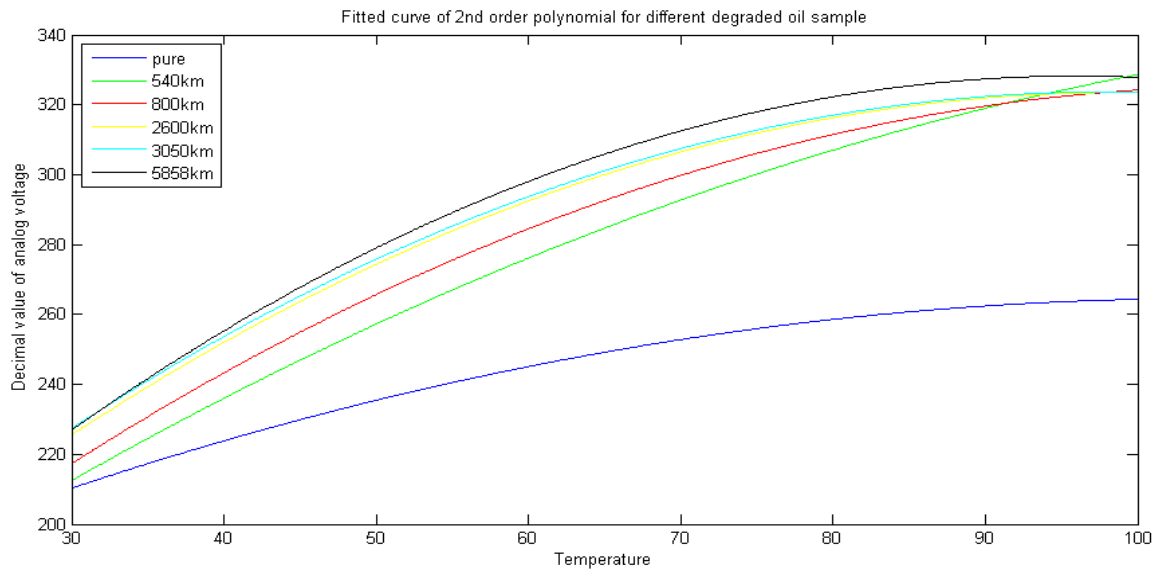

**Fig:4.** Fitted curves of 2<sup>nd</sup> order polynomial for oils with different DoT It has been observed from the graph that

1. The curves for different contaminated oil samples have a significant rising trend at lower temperatures (30°-60°C)
2. The curves of different DoT (except 0 km) intersect with each other within the temperature range of 70°-100°C. This could be attributed to the following causes.
3. Release of moisture and/or water bubbles present in the samples.
4. Release of various occluded gases
5. Increased alignment/ polarization of submerged impurities under the influence of electric field.
6. The samples for DoT 2600 km and 3050 km almost overlapped with one another which may lead to the conclusion that lubricating oils should not be used in motorbikes with DoT above 3000 km.
7. The curve for pure oil sample shows a uniform rising trend over the whole temperature range.

## CONCLUSIONS

A mathematical analysis of degradation of lubricating oil was carried out using the Debye equation. The equation related the dielectric constant of oil with the temperature and kinematic viscosity. The dielectric value was measured using a co-axial cylindrical capacitor. The dielectric constant was related to the output voltage of a capacitive potential divider circuit. A co-axial cylindrical capacitive sensor and LM35 temperature sensor with Atmega32-based microcontroller system have been developed to find the degradation of lubricating oil in terms of DoT. Since the DoT of oil is dependent on temperature, the lubricating oil samples are subjected to temperature variation from 30° – 100°C and the microcontroller based system is used to sample the measure of Temperature and  $V_{out(s)}$ .

## REFERENCES

1. L. Leugner, 2005; “SAE oil Viscosity Classification. The Practical Handbook

- of Machinery Lubrication. Noria Publishing4, 180.
2. AMSOIL Power Sports Group, 2005; A Study of Motorcycle oils. Tech. Rep. 2, 1- 27.
  3. A Carey,1998: The Dielectric Constant of Lubrication Oils. Computational Systems Incorporated 835 Innovation Drive Knoxville,423, pp. 675-683.
  4. Abedian, B., Baker, K. N., 2008: Temperature Effects on the Electrical Conductivity of Dielectric Liquids. IEEE Transactions on Dielectrics and Electrical Insulation, 15, pp. 888-892.
  5. Agoston, A., Otsch, C., Jakoby, B., 2005: Viscosity sensors for engine oil condition monitoring-Application and Interpretation of results. Sensors and Actuators A, 121,327-332.
  6. Knežević, D., Savić, V., 2006: Mathematical modeling of changing of dynamic viscosity, as a function of temperature and pressure, of mineral oils for hydraulic systems. Facta Universitatis Series: Mechanical Engineering, 4, 27 – 34.
  7. Datasheet of LM35 Precision Centigrade Temperature Sensors-Texas Instruments.

**Cite this article as:**

S Bordoloi. (2018). A Mathematical and Experimental analysis of degradation of lubricating oil in four stroke Motorbikes. Journal of Automation and Automobile Engineering, 3(3), 25–32.  
<http://doi.org/10.5281/zenodo.1477198>