

PROTECTION OF SINGLE PHASE INDUCTION MOTOR AND MONITORING

Aditya Narayan Sharma¹, Jaikaran Singh², Deepak Kumar³, Rahul Rajawat⁴, Vibhor Rastogi⁵

Electrical Engineering Department, Moradabad Institute of Technology, Moradabad(U.P.)
mugdha1990@gmail.com

Abstract

In this project we give a special idea of industrial automation, and fault monitoring. Induction motors are the nerves of many industries. Hence industrial automation is required for precise and accurate operation. The project Arduino based parameter monitoring system for induction motor proposes a control and monitoring system for induction motor based on Arduino communication protocol for safe and economic data communication in industrial fields. Current, voltage, and temperature of the induction motors are very important parameters for its control system. The performance of an induction motor is directly affected by these fundamental quantities. However, during continuous operation it is difficult to control the machines. Arduino system is used for collecting and storing data and generate control signal to start or stop the induction machine. We measure the different type of fault such as Over Voltage, Over Current and Over Temperature.

KeywordS: *Arduino, Induction Motor.*

INTRODUCTION

In earlier days dc motors were frequently used for industrial applications. A large number of motors is being used for general purposes in our surrounding from household equipment to machine tools in industrial facilities. The electric motor is now a necessary and indispensable source of power in many industries. The function and performance required for these motor are wide-ranging. With the invention of AC induction motors that have higher overall performance attributes over DC motor, industrial automation are being broadly achieved with it. An induction is an electric motor in which the electric contemporary inside the rotor, needed to produce torque is obtained by means of electromagnetic induction from the magnetic field of the stator winding. the primary benefits of the IM are its reliability, low value, and ease of production with recognize to presently used high overall performance vehicles

however it's miles a great deal more difficult to manipulate.

Single segment and 3 phase induction machines are very popular inside the industries due to their substantial programs. Induction Motor are the maximum extensively used motor for home equipment, induction manipulate, and automation; subsequently they may be roust, dependable and sturdy. Induction motor usually suffers from underneath voltage, over voltage, overheating. Due to this electrical fault the winding of motor get heated which cause insulation failure and as a consequence reduce the existence time of motor. When the Induction motor deliver with better voltage than is rated then induction motor starts off evolved over heated. When deliver voltage is lower than rated then voltage drop across the resistance is better than it protects the motor from this fault. Whilst deliver voltage is lower than voltage drop across the resistance is decrease than precise cost

and motor fails to begin. it's miles especially preferred that Induction motor works freely from the such types of faults. This fault is generated in induction motor due to variant in induction motor parameters. When Induction motor runs constantly, it's miles necessary to shield the motor from these anticipated faults. The safety of induction motor plays a vital function in its long existence provider. The small scale industries are not able to offer expensive protection to the drives in use as it wills growth their capital value. Consequently a cheap and compact design has been executed for safety of induction motor in opposition to under voltage, over voltage, over present day, below modern. Because of the poor electricity quality the harm of induction automobiles in small scale industries desires to be sorted. Therefore it becomes important to protect them against faults on the way to make sure uninterrupted operation and functioning. Numerous parameter controlling and monitoring systems are present for other varieties of system, however in case the of induction gadget the controlling and monitoring structures aren't considerably used because of high cost of set up and physical constraints. in order to triumph over the restrictions in monitoring and controlling, Arduino based gadget is used which makes it fee-effective and easy.

One-of-a-kind tactics have been evolved [1]-[7], for induction motor manage and parameter estimation, but most effective partial results were obtained. In [4] it is managed by means of acquiring records concerning stator flux and motor velocity.

In [3] the manipulate gadget makes use of unknown time varying rotor resistance and cargo torque and in [2] the data is obtained throughout normal operation. After going through all these papers it was concluded that the Arduino primarily based safety system of the induction motor is feasible and may be accurately carried out for the use of business automation.

ABOUT ARDUINO TECHNOLOGY

Arduino/Genuino Uno is a microcontroller board based totally at the ATmega328P. It has 14 virtual input/output pins (of which 6 may be used as PWM outputs), 6 analogy inputs, a sixteen MHz quartz crystal, a USB connection, a strength jack, an ICSP header and a reset button. It carries the entirety had to support the microcontroller; clearly connect it to a computer with a USB cable or energy it with a AC-to-DC adapter or battery to get started..you can tinker along with your UNO without annoying an excessive amount of approximately doing something incorrect, worst case scenario you may replace the chip for a few greenbacks and begin over again.

"Uno" manner one in Italian and was selected to mark the release of Arduino Software 1.zero. The Uno board and version 1.zero of Arduino software were the reference variations of Arduino, now evolved to more modern releases. The Uno board is the first in a series of USB Arduino forums, and the reference version for the Arduino platform; for an intensive list of modern, past or out-dated boards see the Arduino index of boards.

TECHNICAL SPECS

| | |
|-----------------------------|------------------------------------|
| Microcontroller | ATmega328P |
| Operating Voltage | 5V |
| Input Voltage (recommended) | 7-12V |
| Input Voltage (limit) | 6-20V |
| Digital I/O Pins | 14 (of which 6 provide PWM output) |
| PWM Digital I/O Pins | 6 |
| Analog Input Pins | 6 |
| DC Current per I/O Pin | 20 mA |
| DC Current for 3.3V Pin | 50 mA |
| Flash Memory | 32 kb |
| SRAM | 2KB |
| EEPROM | 1KB |
| Clock Speed | 16 MHz |
| LED_BUILTIN | 13 |
| Length | 68.6 mm |
| Width | 53.4 mm |
| Weight | 25 g |

CIRCUIT DIAGRAM

Firstly, the required operating voltage for Microcontroller ATmega328P is 5V. Hence the 5V DC power supply is needed by the same. This regulated 5V is generated by first stepping down the 230V to 12V by the step down transformer. In the power supply the step downed AC voltage is being rectified by the bridge rectifier. The diodes used are IN4007. The rectified AC voltage is now filtered using a 'C' filter. Now the rectified, filtered DC voltage is fed to the voltage regulator. In

power supply the voltage given to Microcontroller 5V is generated using 7805. The rectified, filtered and regulated voltage is again filtered for ripples using an electrolytic capacitor 100µF. Now the output from the first section is fed to ATmega328P Microcontroller to supply operating voltage and from other power supply to circuitry. The Microcontroller ATmega328P with pull up resistors and crystal oscillator of 14MHz in conjunction with couple of capacitors to make it work properly.

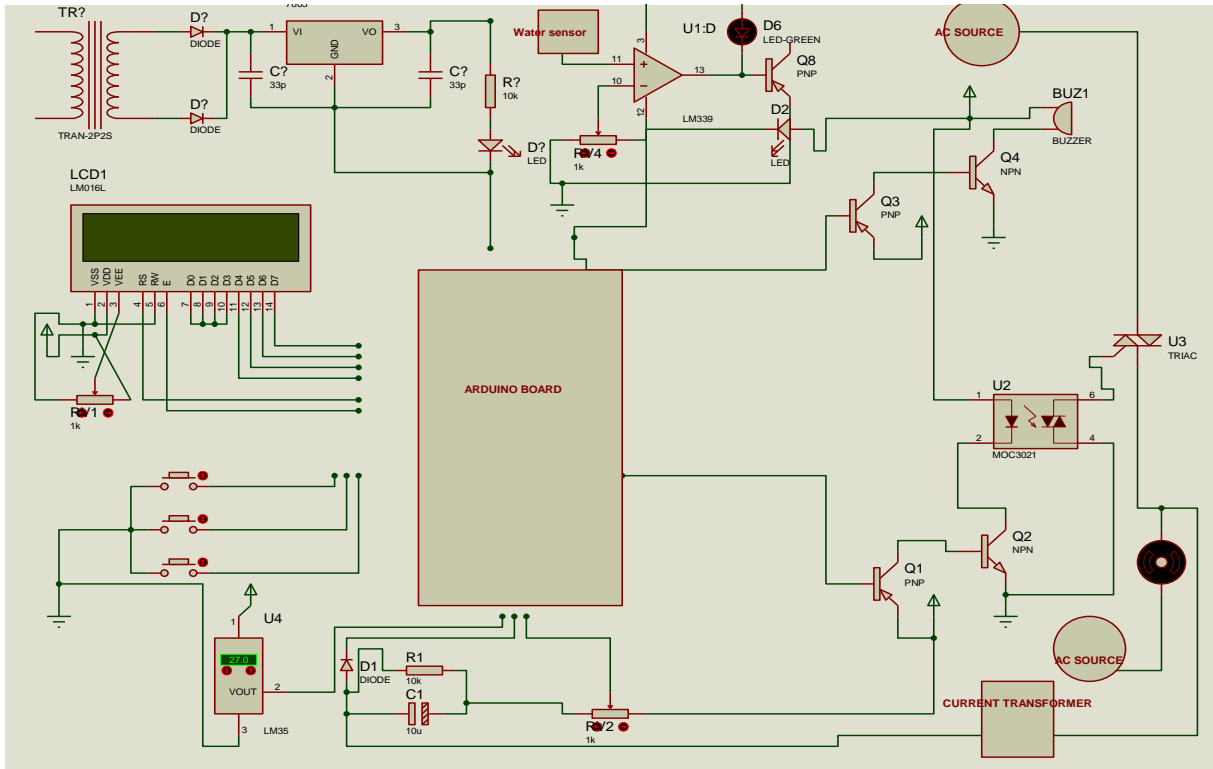

Fig 1. Schematic diagram for IM

HARDWARE RESULTS
STEP 1: Motor section



Fig.2 Circuit for IM



Fig.4 Result in LCD

STEP 2: Arduino Section

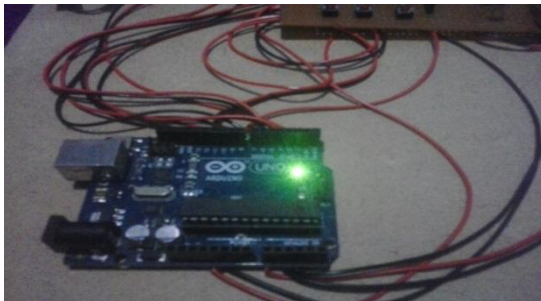

Fig.3 Arduino

STEP 4: Monitor Section

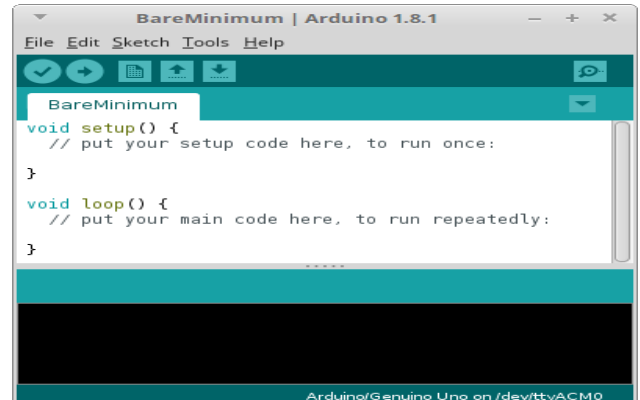

Fig.5 Arduino Window

STEP 3: Motor Section Results Display in LCD

CONCLUSIONS

This paper helps in the control and protection of the induction motor. This paper "Protection of single phase induction motor and monitoring by using Arduino technology" has been successfully designed and tested. Integrating of all the hardware components used has developed it. Presence of every module has been reasoned out and placed carefully. Thus contributing to the best working of the unit. It also put forward a cost effective model for controlling and monitoring of induction machine. Protection system initiates the tripping of the motor under abnormal conditions. The parameter set values are stored in the microcontroller. If the values shows any slight variations from these set values then the relay circuit energizes and the motor trips.

REFERENCES

1. Javed A. and Izhar T., "An improved method for detection of faults in induction motor." Third International Conference on Electrical Engineering, 2009, ICEE09, pp. 1-6, 9-11 April 2009, Lahore.
2. C. Grantham and D. McKinnon "Rapid Parameter Determination for Induction Motor Analysis and Control", IEEE Transactions On Industry Applications, Vol.39, no.4, pp.1014-1020, August 2003.
3. Sudha M. and Anbalagan P., "A Novel Protecting Method for Induction Motor Against Fault to Voltage Unbalance and Single Phasing," 33rd Annual Conference of the IEEE Industrial Electronics Society, 2007, pp.1144-1148, 5-8.
4. Dinesh Pai A, L Umanand, N J Rao "Direct torque control of induction motor with extended Kalman filter", IPEMC Power Electronics and Motion Control Conference, Vol.25, no.7, 2000.
5. Ramazan Bayindir, Ibrahim Sefa, Ilhami Colak, Aslin Bektas, "Fault Detection and Protection of Induction Motors Using Sensors," IEEE Transactions on Energy Conversion, vol. 23, No. 3, September 2008.
6. Pillay P., Hofmann P. And Manyage. "Derating of induction motors operating with the combination of unbalanced voltages and over or under voltages," IEEE Transactions on Energy Conversion, Vol.17, no.4, pp.485-491, Dec.2002.
7. Nuno D. Simoes, Joao L. Goncalves, Maria L. Caeiro, Miguel J. Boavida, Fillipe D. Cardoso, "Arduino/GPS Tracking System for Rowing Races," International Conference on Advances in Mobile Computing and Multimedia, Paris, France, Nov.2010.
8. S. Siddique, G.S. Yadhava, and B. Singh, "A review of stator fault monitoring techniques of induction motors," IEEE Transactions on Energy Conversion, vol. 20, No. 1, pp-106-114, March 2005.
9. F. Filipetti, G. Franceschini, C. Tassoni, and P. Vas, "EAI techniques in induction machine diagnosis including the speed ripple effect," IEEE Transactions India Applications, vol. 34, No. 1, pp.98-108, January/February 1998.
10. Peter Mutschler Darmstadt University Of Technology Department Of Power Electronics And Drives: A New Speed Control Method For Induction Motors.
11. Faiz J., Ebrahimpour H. And Pillay P., "Influence of unbalanced voltage on steady state performance of a three phase squirrel cage induction motor," IEEE Transactions Energy Conversion, Vol.19, no.4, pp.657-662, dec.2004.