

Beam Forming in 5G Frameworks using LTE and 3GPP in Wireless Communication

Ms. Atlanta Choudhury

Assistant Professor

Department of Electronics & Communication Engineering

Girijananda Chowdhury Institute of Management and Technology, Assam, India.

Email: atlanta_ete@gimt-guwahati.ac.in

DOI: <https://doi.org/10.5281/zenodo.1480615>

Abstract

The access bandwidth is measured from 1.3 MHz up to 20 MHz. The fourth generation (4G) wireless communication systems have been deployed currently though like the spectrum disaster and excessive energy intake are the main reason. Wireless machine designers were dealing with the constantly increasing demand for excessive facts charges and mobility required by means of new wi-fi applications which have device works on fifth generation (5G) wi-fi systems which might be predicted to be deployed beyond 2020. By 5G will require both architectural and component stage design changes.

Keywords: *LTE, 3GPP, Massive MIMO*

INTRODUCTION

Millimeter wave (MMW) wi-fi systems are rising as a generation for subsequent cellular communication. Despite the fact that MMW structures have higher propagation loss in comparison to the present cell structures, they can make use of the big bandwidth available in mm-wave spectrum and, similarly, big antenna arrays packed in a very small place thanks to the short wavelength. Those traits permit the layout of multi-Gbps mm-wave structures, as validated in indoor structures which include wireless LAN and wireless PAN. The expansion of wireless networks and increasing use of high statistics charge cell communication has constantly pushed new innovations. One primary factor is the increasing demand of channel capacity.

The innovative and effective use of information and communication technologies (ICT) is becoming increasingly important to improve the economy of the world. Wire-less communication is one of the highest dynamic sector in world. The development of wireless technologies has

greatly improved people's ability to communicate and live in both business operations and social functions [5],[7].

The advances made inside the layout and evolution of fourth technology cellular networks, there are many new requirements to 5G which include excessive-resolution video streaming, tactile net, street safety, far flung tracking, and actual-time manage region new requirements related to throughput, cease-to-quit (E2E) latency, reliability and robustness on the community. The spectrum for cell communications has focused until now is simplest on frequency degrees below 6 GHz. to satisfy call for in the 2020-2030 time frames, spectrum above 10 GHz and potentially as much as one hundred GHz will be wished. Relying at the service frequency, spectrum desires will consist of huge chunks of spectrum in higher bands, TDD mode in unpaired bands and bendy use of spectrum thru advanced spectrum sharing strategies [6].

BACKGROUND

In wireless, satellite and space

communication systems reducing error is critical. High bit error rates (BER) of the wireless communication system require employing various coding methods on the data transferred. Mobile communication has become an everyday commodity. In the last decades, it has evolved from being an expensive technology for a few selected individuals to today's ubiquitous systems used by a majority of the world population. . From the first experiments with radio verbal exchange by Guglielmo Marconi within the 1890s, the street to sincerely cellular radio conversation has been quite lengthy. Now the complex cell verbal exchange structures of these days, it is vital to apprehend in which they got here from and how mobile structures have developed. The task of developing cell technologies has additionally modified, from being a national or regional difficulty to becoming an increasing number of complicated task undertaken by way of international requirements developing companies inclusive of the 0.33 era Partnership undertaking (3GPP) and related to hundreds of people.

Cell communication technology are frequently divided into generations with

1G being the analog mobile radio structures of the 1980s, 2G the primary virtual mobile structures, and 3G the first cellular machine changed into managing broadband statistics. The next generation, 4G or long term Evolution, offers even better guide for mobile broadband. In a long run perspective, round 2020 one may also enter into what some could call 5G radio access. This continuing race of increasing sequence numbers for mobile system generations is in fact just a matter of labels. To get a better quality, need to improve the system design.

THE PROPOSED BLOCK DIAGRAM

Due to the duality between source and channel coding, channel codes at first designed for mistakes safety additionally reap good overall performance in noisy data compression scenarios and even allow lossless compression. Generally, those techniques are based on powerful code instructions: turbo codes and occasional-density parity-take a look at (LDPC) codes. Their commonplace achievement lies inside the change of messages on the decoder in fig 1. Recently, those compression strategies have been prolonged.

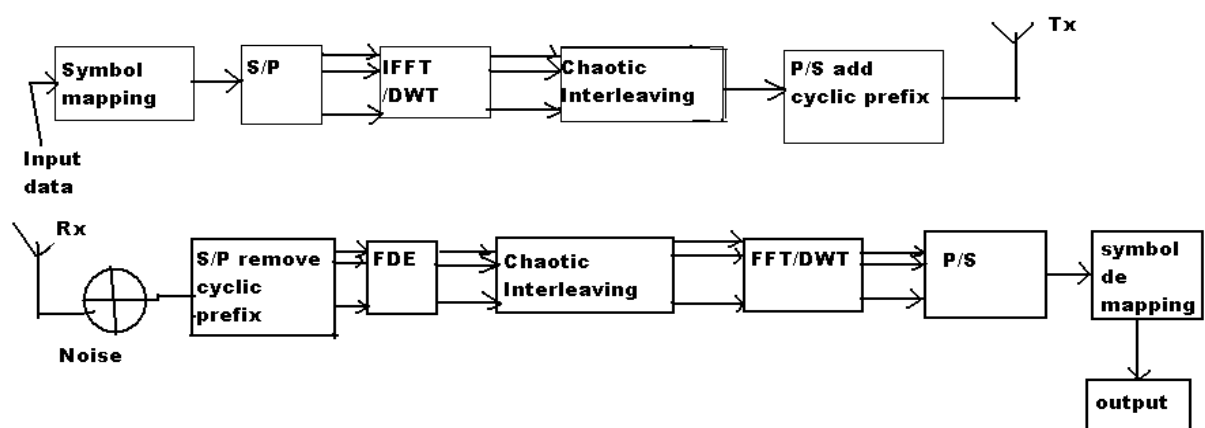

Fig: 1. Proposed block diagram

INCREASED BANDWIDTH USING OFDM

Ever increasing demand for better information rate is the main use of wider

transmission bandwidth. Broadband wi-fi communications affected by multipath frequency selective fading. For broadband multipath channels, conventional time area

equalizers are impractical for complexity reason. Orthogonal frequency division multiplexing (OFDM), which is a multicarrier verbal exchange method, has turn out to be widely regular commonly because of its robustness against frequency selective fading channels which are commonplace in broadband cell wi-fi communication. The inducement turned into to combine the advantages of multicarrier transmission with the potential of CDMA to deal with an extra quantity of users[2].

INTER-CHANNEL- INTERFERENCE

The throughput is defined as the variety of bits consistent with second efficaciously received. Among the throughput and the operation range are observed. Equations are derived for the best preference of the design variables. Those parameters are SNR dependent and can be adapted dynamically in reaction to the mobility of a wi-fi information terminal. The purpose for the fourth era (4G) of cellular communications device is to seamlessly combine a huge type of conversation services which include excessive velocity facts, video and multimedia traffic in addition to voice indicators. One of the promising methods to 4G is adaptive OFDM (AOFDM). In AOFDM, adaptive transmission scheme is employed according to channel fading circumstance with OFDM to enhance the overall performance.

60 GHz CHANNEL MODELING

Time-invariant frequency-selective MIMO channel matrix realizations can be readily obtained. The properties of indoor propagation at 60 GHz are significantly different to those of other “traditional” bands. The main differences are:

- Increased path loss: Due to the shift towards higher frequencies, the free

space attenuation is higher than that of current 2.4 - 5 GHz WLAN.

- Enhanced reflection and scattering: Due to the smaller wavelength (5mm), propagation at 60 GHz has been defined as “quasi-optical” featuring mirror-like reflections and scattering from main objects such as walls, furniture, the floor, the ceiling.
- Increased penetration loss: the penetration loss caused by typical construction materials at 60 GHz is greater than that of smaller frequencies; for this reason, it is highly likely that the receiver can only be used within the same room where the transmitter is located, and inter-room propagation can be neglected.
- The large unlicensed bandwidth around 60GHz and which is more than 3GHz wide will enable very high data rate wireless applications. Secondly, the high free space path loss and high attenuation by walls simplify the frequency reuse over small distances. Thirdly, as the wavelength in free space is only 5mm, the analog components can be made small.

The solution proposed system consists in a semi-deterministic DoD-DoA model (SDCM) based on geometrical optics (RT) and on the available statistical model. The double-directional channel impulse response is found following a GSCM approach, then the MIMO matrix is constructed by incorporating the Tx-Rx antenna array configuration (number of elements and sensor displacement) adopting a finite scattered model[3]. A given double-directional CIR may be evaluated for different antenna sizes. The RT approach for MMW channels was verified to show good agreement with channel measurements.

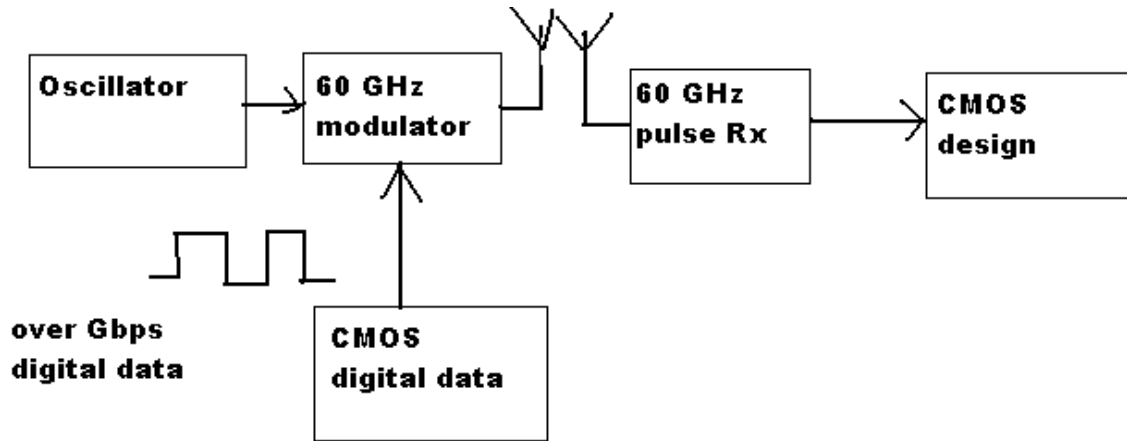

Fig: 2. Block diagram of 60 GHz channel modeling

EFFICIENT METHOD FOR A BETTER BER

5G systems exhibit better BER performance as that of LTE-A, because of mentioned features. Also BER expressions are derived and validated using simulation results in fig 3. By increasing number of users, BER performance degrades in all mentioned systems. So, work can be extended to develop algorithms which further enhance coordination among cells, high cell edge throughput, high network coverage and high interference

suppression. It is given by the following formulae.

$$BER = \text{Number of Error Bits} / \text{Total Number of Transmitted Bits}$$

Beam forming solutions such as Minimum Mean-Square Error (MMSE), Minimum Variance Distortionless Response (MDVR) and Dominant Eigenmode Transmission (DET) cannot be applied to the Tx-Rx ABF system design. A frequency-selective behavior due to the multipath channel and the broad transmission bandwidth can be implemented for 5G.

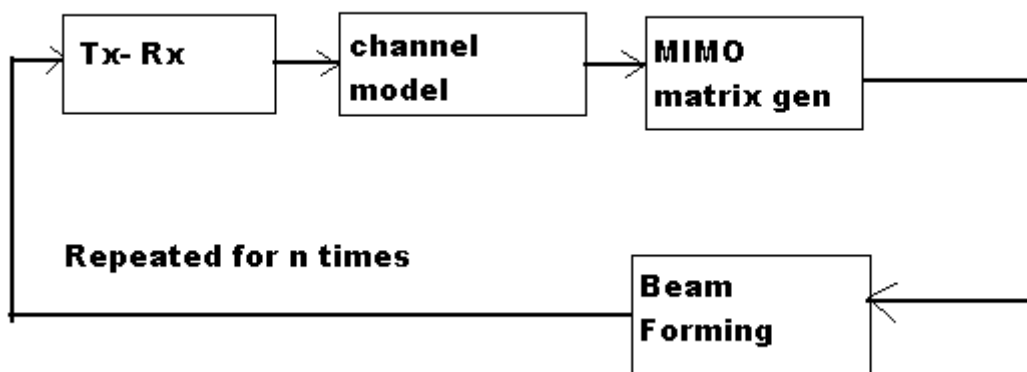

Fig:3. Schematic of BER calculation

CONCLUSION

The specific features supply varying overall performance gains and will have certain influences at the device complexity and price. MIMO schemes up to 8x8 will

for example notably enhance peak statistics prices and spectral efficiency. Some of this selection could have big impact at the network aspect for antenna installation and on the UE complexity

(additional transmission/reception chains). The performance necessities of 5G wireless verbal exchange systems were defined in phrases of ability, spectral performance, strength performance, records charge and cellular average throughput. A brand new heterogeneous 5G mobile architecture has been proposed with separated indoor and outside applications using DAS and big MIMO generation [4].

REFERENCES

1. Zhuangkun Wei, Bin Li and Chenglin Zhao, "On the polar code for the 60-GHz millimeter-wave systems" Wei et al. EURASIP Journal on Wireless Communications and Networking (2015) 2015:31 DOI 10.1186/s13638-015-0264-y
2. Federico Boccardi, Vodafone Robert W. Heath Jr., University of Texas at Austin Angel Lozano, UniversitatPompeuFabra Thomas L. Marzetta, Bell Labs, Alcatel-Lucent PetarPopovski, Aalborg University, "Five Disruptive Technology Directions for 5G"
3. Cheng-Xiang Wang, Heriot-Watt University and University of TabukFouratHaider, Heriot-Watt University XiqiGao and Xiao-Hu You, Southeast University Yang Yang, ShanghaiTech University Dongfeng Yuan, Shandong University, "Cellular Architecture and Key Technologies for 5G Wireless Communication Networks, "5G Wireless Communication Systems Prospects and Challenges"
4. Ekram Hossain, MonowarHasan, " 5G Cellular: Key Enabling Technologies and Research Challenges" paper presented in the conference.
5. C. Guillemot and P. Christ, "Adaptive CSI and feedback estimation in LTE and beyond: a Gaussian process regressionapproach,"Chiumento et al. EURASIP Journal onWireless Communications and Networking 2015, DOI 10.1186/s13638-015-0388-0.
6. L. Camiciotti, C. Lamy, L. Meilhac, S. Oliveieri and P. Verdi, "Variable-step-size based sparse adaptive filtering algorithm for channel estimation in broadband wireless communication systems," In Gui et al. EURASIP Journal on Wireless Communications and Networking, 2014.
7. M. W. Garrett and M. Vetterli, "On massive MIMO performance with semi-orthogonal pilot-assisted channel estimation," Zhang et al. EURASIP Journal on Wireless Communications and Networking, 2014.

Cite this article as:

Ms.Atlanta Choudhury. (2018). Beam Forming in 5G Frameworks using LTE and 3GPP in Wireless Communication. Journal of Analog and Digital Devices, 3(3), 11–15. <http://doi.org/10.5281/zenodo.1480615>