

Smart Cultivation

Dr.A.Sheela^{1}, Ms.K.Kavinmullai², N.Bhuvanesh³, S.Karthikeyan⁴, N.Mohamed salmaan⁵*

^{1,2}Associate Professor, ^{3,4,5} Students

*¹⁻⁵Department of electronics and electrical engineering,
¹⁻⁵Kongu Engineering College, Perundurai, Tamil Nadu, India*

Email: a_sheela@kongu.ac.in

DOI: <http://doi.org/10.5281/zenodo.2620813>

Abstract

The proposed project is about a serious issue in today's world that is insufficient food production, which prevails in many parts of the world. Farming plays an important role in food production and economic development in India and in the world as a whole. Getting high yield from the available land depends on fertility, moisture content of the soil and other climatic factors. The proposed work helps to overcome this problem, which aims at developing an automatic fertilizer-irrigation control and management system. It improves soil porosity and nutrient content through periodic application of required amount of fertilizers and water for crop's growth. This will metabolize the soil texture, give nutrients to the crops, build plant tissues as well as increase the rate of crop productivity. The implementation of the work is achieved by sensors which include potassium sensor, nitrogen sensor, humidity sensor and temperature sensor, applying Intelligence technique by using Arduino nano to control the valve of the irrigation system. The system automatically applies soluble agrochemical fertilizers and water based on plant needs, as a result of which productivity is increased to considerable amount to meet out increasing needs.

Keywords: *Irrigation system, Automatic fertiliser system, automatic irrigation system Arduino*

INTRODUCTION

Several hundred years ago, Indian farmers had begun cultivating foods and sugarcane. India has large agriculture cultivating land (215.6 million acres) in the world. Agriculture sector has the highest percentage of role in Indian Economy. Agriculture is most important and powerful sector of Indian Economy. Indian agriculture sector is have more per cent (18%) in India's Gross Domestic Product (GDP) growth. India is the world's largest producer of legume, rice, wheat, spices and spice products. In recent centuries chemical Fertilizer[1] more used in agriculture and now a days most of people interest in organic agriculture [3]. Organic fertilizer involves Organic production that offers clean and green production techniques without use of synthetic fertilisers and pesticides and it achieves a premium price in the market.

India has 6,50,000 organic producers, which is more than any other country. Since synthetic fertilizers are not used, building and maintaining a rich, living soil through the addition of organic matter [3] is a priority for organic farmers. Organic matter can be applied through the application of manure, compost, and animal by-products, such as feather meal or blood meal. Methylococcus capsulatus bacteria [6] is used in organic production of protein rich cattle, fish and poultry feed using biogas /methane/natural. Fertigation (fertilizer + irrigation)[6] system may be defined as the combination of irrigation and fertilizer application to the soil. Fertigation system used for improve crop production and plant growths. Irrigation systems helps to the growing of agricultural crop, maintenance of landscapes and re-vegetation of disturbed

soil in the dry area and during the periods[4] of inadequate rainfall irrigation system used for Farming. But in now a days there is rare in organic agriculture and farmers. So our project is based on organic agriculture with no man power requirement[2]. It automatically fertilizes the farm based on crop and in a regular time intervals with essential organic fertilizer.

LITERATURE REVIEW

Auto fertilizing, is an existing method which is based on the ph value and according to which fertilization process takes place, based on the moisture content, and the irrigation process takes place[1]. But it's not a proper manner for fertilization because any crop needs a different type of fertilizer during their different stages of growth and also the existing system cannot judge the fertilizer required. It is only based on ph value [1] but the fertilizer depends on type of crop and requires different type of nutrients during different time period. The drawbacks of existing system are:

- Man power requirement to provide fertilisers
- Time consuming process
- Involves chemical process

Various literatures are reviewed on this specific area of interest. Divya and Rashid in their paper titled "Seeding and fertilization using automated robot" proposed machine assembled method [2] for sowing seeds and spraying fertilizers for large areas of land without any human intervention [2]. The technology utilize in this work is an interface between artificial intelligence and robotics. Agriculture plays an major role in Indian economy, hence farming is greatly helped by such an invention that takes off an extra burden from the shoulders of small and large-scale farmers [3]

Cyril Joseo, Aadeshbhaskar & I.Thirunavukarasu suggested "Fertigation

system" as the process of delivering plants nutrients along with water to produce a quality crop with higher yields [4]. Exploit an automated fertilized irrigation system can help farmers by significantly optimizing water and other nutrient usage [2]. The objective is to automatically maintain the wetness level in the ground and to mix different fertiliser to obtain the required Nitrogen(n) Phosphorus(p) Potassium(k) ratio and give it to plants along with irrigation system [2], [6]. This work is carried out in two parts, in which one is maintaining the optimum level of moisture in the soil. A soil moisture sensor which senses the moisture content in the soil is used. The sensor output is given to the controller, which decides if more water needs to be pumped or not. Then a control system for the fertilizer mixing and delivery part is designed [7]

Prashant S. Patil Shubham R. Alai Ashish C. Malpure & Prashant L.Patil in their paper titled "Drip Irrigation System Using Sensors Network Control System", they suggested [3] just used trip system for irrigation with the help of sensor network control system without using normally closed and open contact valves just measured the soil content and did not measure the humidity and irrigation on the top of the soil [5], [3].

In this paper a novel idea is proposed to bridge the gaps identified in the existing literature.

OBJECTIVE

The main objective of this project is to minimize or to overcome the problem faced by the need of knowledgeable person to choose which type of fertilizer needed for the soil to cultivate the crop properly[2], [5]. This is very effective for those who don't have any knowledge about amount of fertilizer to be applied for a particular plant.

The purpose of selecting automatic fertilized irrigation system are follows :-

- Sensing of minerals and humidity in soil
- Checking the minerals value with predefined mineral range for particular crop
- Providing sufficient mineral to equalize deficiency
- Supply of water when the soil gets dry in order to improve cultivation

METHODOLOGY

The proposed system is placed in a selected crop field. The nutrient is supplied at the right time to the crop when needed [1]. The mixture tank consisting of fertiliser and waters [6], is connected to the different organic fertilizer tanks. Sensors namely, Moisture sensor and Potassium sensor, are connected to Arduino nano and arduino is connected to solenoid valve, pump and sensor elements [3]. Moisture sensor is used to measure the moisture content in the soil. If the moisture content is low then the trip irrigation system gets operated and sprays the water on the soil [2]. For every week once, fertilisers like panchakavya and effective micro-organism are sprayed on the plant for timely applications (panchakavya fertiliser – For make root strong and Effective micro-

organism – For make high growth rate). Potassium sensor is used to measure the nutrient content in the soil [4]. Arduino receives the data from the sensors[2] and organic fertilisers are sprayed on the plant when it is required. It is very helpful for the farmers to attain Economic growth in the crop cultivation. GSM module is connected to arduino to indicate the type of fertiliser sprayed on the plant to the user[7]. LCD display is also interfaced with the proposed system.

MAIN BLOCK DIAGRAM

The proposed block diagram consists of potassium Sensor, temperature sensor, humidity sensor, controller and LCD. The ground humidity level is measured the by humidity sensor and the level is send it to amplifier and the amplifier amplify the signal low level to high level [4]. The high level signal is given to the ADC which converts the analog signal to digital signal. The digital signal is sent to the controller [2]. According to the humidity value, the proportion of the organic compound [4] present in the soil will be derived and also the preferred vegetation for the humidity value is suggested. Figure 1 shows the main block diagram.

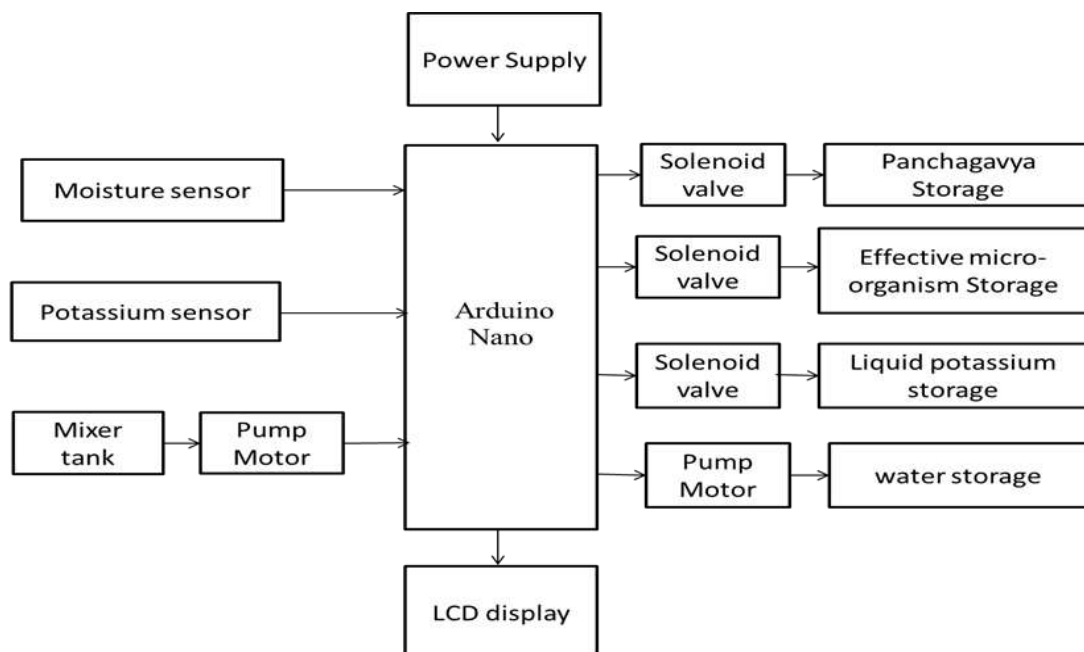

Figure 1: Main Block Diagram

Organic fertilizers are natural fertilizers made from animal matter, animal waste, and vegetable matter naturally occurring organic fertilizers include animal wastes from meat processing, peat, manure, slurry, and guano in contrast, the majority of fertilizers used in

commercial farming are extracted from minerals or produced industrially[3]. Organic agriculture, a system of farming, allows for certain fertilizers and amendmnts and dissolved. Fertilizers used in this project with time specification are

Table 1: Organic fertilizers

Effictive Micro – organisam	every weeks once for root make strong
Panchagavya fertilizer	every weeks once for high growth rate
Liquid potassium fertilizer	every weeks once for make cultivate good

HARDWARE IMPLEMENTATION

The ground level is measured by the potassium and moisture sensor and the data is sent it to amplifier. The high level signal is given to the ADC which converts the analog signal to digital signal. The digital signal is sent to the micro controller based on sensor value. The proportion of

the organic compound present in the soil will be derived and also the preferred vegetation for the fertilizers are suggested using Arduino Nano. Fertilizer and water mixed in mixer tank is sprayed to land using sprinkler system. Water is supplied to the land based on the moisture level. Figure 2 shows the Hardware setup.



Figure 2: Hardware Setup

FLOWCHART (WORKING FOR ONION CROP USING ORGANIC FERTILIZERS)

The flowchart is shown in figure 3.

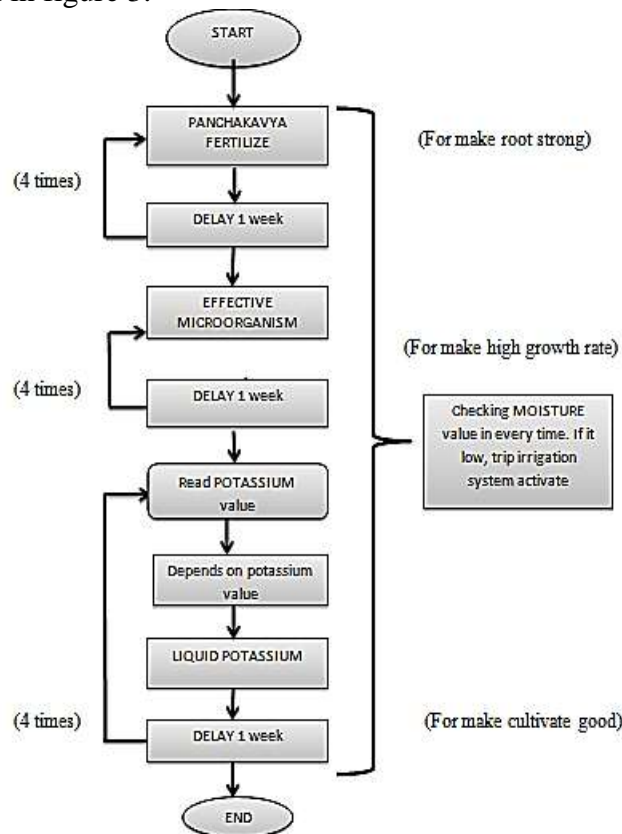

Figure 3: Flowchart

CONCLUSION & FUTURE SCOPE

In this paper, a fertilizer irrigation system that can manage and improve the yield of crop has been developed. The proposed method offers best fertilizer ratios by measuring the sensor values of soil and this recommended value of fertilizer can be used for fertilizing the soil in accordance with the crops. Venturi system is implemented in real time for providing fertilizer and irrigation process. The purpose of the system is measuring soil moisture parameters and display the information as farmer required for any time and take action to whenever the problem in this system. Main objective of the system is operate without the human intervention and reduce farmers effort and energy required for the cultivation of greenness crops during the dry season. To improve the performance of this system, other soil parameters for the intelligence system and decision making can be designed.

REFERENCES

1. Viscera Rossel RA, Thylén L, McBratney AB & Gilbertsson M 2004. Development of an on-the-go soil sensing system for determinations of soil pH and lime requirement. Paper presented at the 7th International Conference on Precision Agriculture, Minneapolis MN, USA.
2. Birrell SJ & Hummel JW 2001. Real-time multi ISFET/FIA soil analysis system with automatic sample extraction. Computers & Electronics in Agric., 32: 45-67.
3. Sowah RA, Armoo SK, Koumadi KM, Agyeman R & Fiawoo SY 2014. Design and development of an efficient and cost-effective microcontroller-based irrigation control system to enhance food security. World Acad. Sci. Engr. & Techn; Int. J. Electrical, Computer, Energetic, Electronic & Communi. Engr., 8(8), 1343-1350

4. Umair SM & Usman R 2011. Automation of irrigation system using ANN based controller. Int. J. Electrical & Computer Sci. IJECS-IJENS, 10(02).
5. Venkata NRG 2013. Microcontroller based automatic plant irrigation system. Int. J. Advancement in Res. & Techn., 2(4): 194-198.
6. Riza M, Winda A & Kasim NA 2011. Solar-based fuzzy intelligent water sprinkle system. J. Mechanics, Electrical Power, & Vehicular Techn., 2(2), 65-72.
7. Shiraz P & Yogesha B 2014. Microcontroller based automated irrigation system. Int. J. Engr. & Sci., 3(7): 6-9.

Cite this article as:

Dr.A.Sheela, Ms.K.Kavinmullai, N.Bhuvanesh, S.Karthikeyan, & N.Mohamed salmaan. (2019). Smart Cultivation. Journal of Advancement in Machines, 4(1), 34–39. <http://doi.org/10.5281/zenodo.2620813>