

2019

## Accessible Design in Rural Health care: Usability Profile of Outpatient Health Care Facilities in Rural West Virginia.

Jordan E. Miller

West Virginia University, jem0031@mix.wvu.edu

Follow this and additional works at: <https://researchrepository.wvu.edu/etd>



Part of the [Community Health and Preventive Medicine Commons](#), [Disability Studies Commons](#), and the [Other Architecture Commons](#)

---

### Recommended Citation

Miller, Jordan E., "Accessible Design in Rural Health care: Usability Profile of Outpatient Health Care Facilities in Rural West Virginia." (2019). *Graduate Theses, Dissertations, and Problem Reports*. 3785. <https://researchrepository.wvu.edu/etd/3785>

This Thesis is protected by copyright and/or related rights. It has been brought to you by the The Research Repository @ WVU with permission from the rights-holder(s). You are free to use this Thesis in any way that is permitted by the copyright and related rights legislation that applies to your use. For other uses you must obtain permission from the rights-holder(s) directly, unless additional rights are indicated by a Creative Commons license in the record and/ or on the work itself. This Thesis has been accepted for inclusion in WVU Graduate Theses, Dissertations, and Problem Reports collection by an authorized administrator of The Research Repository @ WVU. For more information, please contact [researchrepository@mail.wvu.edu](mailto:researchrepository@mail.wvu.edu).

Accessible Design in Rural Health care:  
Usability Profile of Outpatient Health Care Facilities in  
Rural West Virginia.

Jordan E. Miller

Thesis submitted to the  
Davis College of Natural Resources and Design  
at West Virginia University  
in partial fulfillment of the requirements

Master of Science  
In  
Design & Merchandising

Chris Haddox, Ph. D, Chair  
Lesley Cottrell, Ph. D  
Shan Jiang, Ph. D

Davis School of Design and Community Development  
Morgantown, West Virginia  
2019

Keywords: Disability, Health Care, Rural, West Virginia,  
Accessibility, Design

Copyright 2019 Jordan Miller

## ABSTRACT

### Accessible Design in Rural Health care: Usability Profile of Outpatient Health Care Facilities in Rural West Virginia

Jordan Miller

The Americans with Disabilities Act (ADA) became law in 1990. Since then, research has shown that people with disabilities continue to experience environmental, systematic, and structural barriers to health care. The purpose of this research is to explore the prevalence of barriers in rural West Virginia health facilities and the relationship between building characteristics (like age and purpose) and accessibility. The researcher evaluated ten rural outpatient member-sites of the West Virginia Practice-Based Research Network using a survey to understand building characteristics and a tool to measure essential features for a facility to be considered 'usable'. Findings included a negative correlation between building age and accessibility score. The results showed that once adjusted for items that did not apply to specific clinics, surveyed clinics scored an average of 73% in overall accessibility. Counters, restrooms, and exam rooms were the lowest scoring categories. The study also found a moderate negative correlation (Spearman  $p = .6274$ ) between the age of the building and overall score and a strong negative correlation (Spearman  $- .71$ ) between the age of building and Mobility score. In addition, this research found a moderate statistical difference mean in usability score of buildings retrofitted to house medical offices. This research supports the notion that physical and environmental barriers to health care access still exists and that older clinical buildings run a higher risk of being non-compliant with essential ADA items and thus, contribute to barrier creation.

## ACKNOWLEDGEMENTS

The past three years I have come to learn that conducting and writing research is not easy. I came into this program as someone determined to do things on my own and academic research certainly allows for that opportunity. However, what I am leaving with is the realization that education is a collaborative process. During my time at WVU, I have had the privilege to work with people from all backgrounds who deeply care about helping others whether that be for people struggling with disabilities or students struggling to complete research and I want to thank some of those people specifically.

First of all, I want to thank my committee. Dr. Chris Haddox, my committee chair, worked with me through several bad research topics always in a realistic and encouraging way before I chose Accessible Design in Rural Healthcare. You have single-handedly allowed me the opportunity to grow as an academic and an individual through your support and by employing me as your research assistant. I want to thank Dr. Lesley Cottrell, for encouraging my research and kindly taking the time to help me build the foundation of my statistical analysis. I want to thank Dr. Shan Jiang for being an expert addition to my committee and for offering your expertise and encouragement.

I want to thank the WVPBRN. You have all been the most hands-on members of this team at every phase. Everyone at the WVCTSI and WVPBRN has shown such interest and support and that helps a lot. Stacey Whanger, thank you for always showing faith in this project even and for all the work you did in organizing sites. Angie DeWitt, thank you for being so responsive and professional and doing much of the leg work in the organization process. Thank you to all the member site who participated in the study. I hope it was beneficial for you.

I want to thank WVU and the Davis College for extending an opportunity to a student with a vague idea of what he wanted to do and all the faculty that made the process easier. Ida Holaskova, thank you so much for working with me on statistical analysis. You are so intelligent and patient and much research out of Davis College is due to your dedication. Peter Butler and

Katie Jones, thank you for your engaging and informative seminars which help me and all Davis College students navigate the tedious and numerous research processes.

I briefly want to acknowledge the Geography and Planning Department of West Liberty University. Dr. Robert Kruse is the person who inspired me to apply for graduate school and helped me through the admissions process. No professor has ever so willingly offered their time to me as much you have. Thank you for that.

Finally, I want to thank my supportive friends and most importantly my family: Mom, Dad, and Emily. Through most of this process, I know you struggled to understand the purpose of my educational choices or the role it played in my future. I know you struggled to explain to people exactly what I was doing and why. That said it never stopped you from supporting me in every possible way. I know you believe in me and completing this program has allowed me to believe in myself. I always strive to make you proud even as I learn an individual set of values along the way. I love you. You are the foundation of my success, and these three years have served as building blocks to a lifetime pursuit of education, character, and opportunity.

## TABLE OF CONTENTS

CHAPTER I: INTRODUCTION.....	1
BACKGROUND.....	1
HISTORY OF DISABILITY POLICY IN AMERICA .....	3
ACCESS IN THE MODERN ERA .....	5
PROBLEM STATEMENT .....	7
PURPOSE OF STUDY/ RESEARCH QUESTIONS.....	7
CHAPTER II: REVIEW OF LITERATURE .....	9
INTRODUCTION .....	9
BARRIERS TO ACCESS .....	9
PREDICTING BARRIERS TO ACCESS .....	13
STATE OF PUBLIC HEALTH IN WEST VIRGINIA.....	13
RURAL ACCESS TO CARE.....	15
THE ADA AND ITS ATTEMPT TO ADDRESS DISPARITY .....	16
OHCUP AND OTHER EVIDENCE-BASED EFFORTS .....	17
CHAPTER III: METHODS.....	20
PURPOSE OF STUDY .....	20
RESEARCH DESIGN .....	20
SAMPLE.....	21
MEASUREMENT TOOLS .....	22
<i>Survey</i> .....	22

<i>Outpatient Health Care Usability Profile</i> .....	23
PROCEDURE .....	25
DATA ANALYSIS .....	28
CHAPTER IV: RESULTS.....	30
DEMOGRAPHIC AND SURVEY RESULTS .....	30
OHCUP ORGANIZATION .....	32
<i>Major Categorical Results</i> .....	32
<i>Sub-categorical Results</i> .....	33
<i>Individual items most commonly found in non-compliance</i> .....	39
CORRELATIONAL ANALYSIS FOR APPROXIMATE AGE.....	47
PAIRED SAMPLE T-TEST FOR MEDICAL PURPOSE .....	48
CHAPTER V: CONCLUSION.....	52
THE NEED FOR RESEARCH .....	52
SUMMARY OF FINDINGS .....	53
LIMITATIONS.....	55
DISCUSSION AND FURTHER RESEARCH .....	57
REFERENCES .....	60
Appendix A.....	68
Appendix B.....	71
Appendix C.....	72

Appendix D.....75

Appendix E.....171



## LIST OF FIGURES

Figure 1 People Living with Disabilities in the United States.....	14
Figure 2 Shift Density of Industries in West Virginia.....	15
Figure 3 Rural Healthcare Facilities in West Virginia.....	15
Figure 4 Usability Scores.....	32
Figure 5 Mobility Score vs Approximate Age.....	46
Figure 6 Overall Score vs Approximate Age.....	46
Figure 7 N/A Adjusted Score vs Approximate Age.....	46
Figure 8 Medical Purpose Effect on N/A Adjusted Score.....	49
Figure 9 Medical Purpose Effect on Mobility Score.....	49
Figure 10 Medical Purpose Effect on Overall Score.....	49
Figure 11 Medical Purpose Effect on Cognitive Score.....	50

## LIST OF TABLES

Table 1 Demographical Characteristics.....	30
Table 2 Sub-Categorical Results (Not Adjusted).....	33
Table 3 Sub-Categorical Results (N/A Adjusted).....	37
Table 4: Individual Items Commonly in Non-compliance.....	39



## CHAPTER I

### **Introduction**

#### **Background**

In the United States, accessibility is a right with roots that extend the early 1970s, a time in which the country was forced to face the reality of discrimination. This realization brought with it a tremendous leap towards equality that continues to this day. However, the simple notion of equality, which is more readily achievable across cultures, would face decades of struggle for the single largest minority group in America: people with disabilities (Mayerson, 1992). This is because even after policy was put in place to legally require accessible structures be built, that policy has primarily been effective in new and reconstructed facilities (Pharr & Chino, 2012). This gap has extended decades past the passing of the ADA (American's with Disabilities Act, 1990) and acts as a continued barrier to accessible health care. In rural America, patients with disabilities not only face similar economic and cultural barriers felt across the nation, but often face a unique set of environmental challenges, such as distance (Buzza, Ono, Turvey, Wittrock, Reddy & Reisinger, 2011). As strides towards full ADA compliance continue, many rural facilities fall through the cracks, even in health clinics, where access is especially important for the health and quality of life of the individual. The purpose of this study is to investigate specific access barriers that are hindering the usability of health care facilities in rural West Virginia.

The state of West Virginia has a host of public health challenges. It has the highest rate of non-institutionalized working-aged people with disabilities in the country and the second highest population of adults age 65 years or older; a population expected to increase 16%-24% in the next two decades (Christiadi, 2019). West Virginia leads the country in obesity and ranks fifth in poverty (The State of Obesity, 2019; U.S Bureau of the Census, 2010). The U.S. Department of Health & Human Services Office of Rural Health Policy designates 43 of the 55 counties in West Virginia to be rural (West Virginia Department of Education, 2019), and 28 counties contain parts which score the highest rating for rurality (10.0) according to the Rural-Urban Commuting Area (RUCA) codes (2019). Rural patients face an added challenge of further distances to receive general and specialized healthcare (Buzza, Ono, Turvey, Wittrock, Reddy & Reisinger, 2011).

While rural Americans face a host of accessibility barriers (Buzza, Ono, Turvey, Wittrock, Reddy & Reisinger, 2011), this research takes a specific look at physical access barriers within outpatient health care facilities. Within a rural setting the added barrier of distance creates an emphasis on ensuring physical accessibility of healthcare facilities (Buzza, Ono, Turvey, Wittrock, Reddy & Reisinger, 2011), and the lack of preventative care received among patients with disabilities highlights the significance of evaluating outpatient healthcare accessibility reasons (Pharr & Bungum, 2012; George & Mosqueda, 2008). This study will use the Outpatient Health Care Usability Profile (OHCUP) to evaluate outpatient healthcare facilities. This tool measures compliance with items in the Americans with Disabilities Accessibility Guidelines (ADAAG) that are critical to physical access for patients with disabilities. It consists of 103 items that researchers out of the University of New Hampshire and

The University of Oregon believe to be the minimum for a facility to be ‘usable’ for patients with disabilities (Drum, Horner-Johnson, & Walsh, 2012). In order to best interpret the results, a review of literature found similar studies in other states and leading factors in non-compliance. Correlating factors for ADA non-compliance in 68 primary health care sites in South Carolina most notably included building age and administrative knowledge (Graham & Mann, 2008). In addition to replicating these findings, this research seeks to explore if buildings retrofitted to accommodate health care offices score significantly different from buildings originally built to house medical offices. Understanding the role that retrofitting plays in physical accessibility of health clinics is not a topic this researcher has found in a review of literature. But, as retail health clinics (fitted inside of supermarkets, shopping plazas, pharmacies, etc.) gain customer acceptance and improve access to healthcare, ensure the physical accessibility of those spaces is of added interest to this research (Mullin, 2009).

### **History of Disability Policy in America**

In 1973, Section 504 of the Rehabilitation Act banned discrimination on the basis of disabilities by programs that receive federal financial assistance. For the first time, exclusion and segregation of people with disabilities was considered discriminatory. After the passing of Section 504 began a long-fought battle in defining its scope, with many advocates arguing that the policy should expand to cover architectural and communication barriers as well.

During the 1980s, the Reagan administration fought to strip away civil right protections and deregulate Section 504 as a way to promote business and economic growth. After the Reagan office was bombarded with letters from grass root organizations urging him not to challenge Section 504, the administration eventually ceased all attempts to deregulate the

legislation. The spirit and resilience of this effort left a mark on the incoming Bush administration who used Section 504 as the basis of the ADA (Mayerson, 1992).

The ADA (first drafted in 1988) was subject to a number of revisions during its time in Congress, often in an attempt to water down its regulations. For the first time, public facilities of all types were going to be subject to accessibility guidelines. Opponents worried that the bill would be too costly for local business and transportation and lead to litigation as well as a subsequent decline in employment opportunities for individuals with disabilities (Mayerson, 1992). As a response, stories of disability discrimination were told on the floor of Congress, plastered throughout the media, and flooded the offices of local policymakers. As perhaps the most famous act of protest, proponents of the bill organized a demonstration in which over 60 activists abandoned their wheelchairs and mobility devices and began crawling up the 83 steps to the entrance of the Capitol Building. The protest left a powerful image in the minds of lawmakers who passed the bill, making discrimination based on disabilities illegal, including limiting access to public accommodations (The Americans with Disabilities Act of 1990 – ADA, n.d.).

Since ratification in 1990, the ADA continues to improve through amendments and litigation clarified by the Supreme Court. Regulations for the first three acts of the ADA were finalized on July 26, 1990. Title I and Title II covered equal employments and public services, respectively. Under Title III of the ADA all public facilities needed to be accessible to people with disabilities as per the ADAAG. The ADAAG consists of nearly 700 technical requirements to ensure equal access to people suffering from mental or physical disabilities. In 2008, the ADA Amendments Act redefined the scope of the term disability to include more patients.

Before that there had been twenty ADA related cases heard in the Supreme Court, five having to do with the definition of disability (ADA – Findings, Purpose, and History, n.d.). Despite all this, people with disabilities continue to battle discrimination in terms of physical and programmatic barriers to access, both generally and in a health care setting (Drum, Horner-Johnson, & Walsh, 2012).

### **Access in the Modern Era**

Since the establishment of the ADA and as of 1993, newly constructed buildings must successfully meet the ADAAG requirements and existing buildings are required to adhere to the same standard, so long as adherence does not cause “significant difficulty or expense”(Americans with Disabilities Act, 1990). Progress, however, has been slow and many facilities remain non-compliant with certain regulations (Graham & Mann, 2008). Non-compliance of accessibility standards sustain disparities for patients with disabilities in the United States, which, in any capacity, is unacceptable for the simple fact that it is illegal. Every citizen has the right to quality care and discriminatory barriers within health care facilities impede on that right. In addition, these discriminatory barriers could play a role in lower quantity of care for patients with disabilities. Working-aged people with disabilities prove to have far lower rates of health services such as blood pressure checks, cholesterol screenings, mammography, and far lower rates of health behavior counseling around issues related to alcohol and substance abuse, diet and eating habits, regular physical exercise, and smoking cessation (Pharr and Bungum, 2012).

Full compliance with ADA regulation is not always readily achievable. Old and retrofitted health care facilities face fundamental structural challenges in becoming compliant.



The year of construction is the most reliable indicator of overall accessibility (Graham & Mann, 2008). Facilities posed with making some of these costly changes may risk their business and, as a result, limit accessibility to health care services for everyone. Framers of the ADA sought to avoid this through methods of enforcement, described in greater detail in a review of literature.

Lack of knowledge of accessible design policy additionally plays a role in the lack of accessibility within health clinics. A study out of Las Vegas University, which tested the ADA knowledge of health care administrators found an “inverse relationship between the knowledge that an administrator has of the ADA and the number of barriers found in his/her clinics” (Pharr & Chino, 2013, p.119). The same study found that most administrators were unaware of tax credits available for facilities that undertake barrier removal or alterations in compliance with the ADA. The ADA is complex; the Accessibility Guide consists of 700 technical requirements which both health administrators and general contractors must understand when designing new or updating facilities. While all 700 requirements serve a particular purpose, knowing and enforcing them in design practice (and within academic research) is often impractical. As a response the ADA developed modified versions of the ADAAG targeting readily achievable barrier removal. The most recent being the 207-item ADA Checklist for Existing Facilities (2010). This tool lists relevant items of the ADAAG that may impede access to services particularly in facilities built prior to the passing of the ADA.

Large-scale studies measuring ADA compliance have been completed using additional modified versions of ADAAG. For example, a study out of South Carolina used a modified ADA assessment checklist assessing the accessibility of primary care physician practices. This checklist, developed by rehabilitation engineers, consisted of 93 items. Investigators found that

the average practice was adequate on 70% of the items assessed (Graham & Mann, 2008). The 93 items assessed are only a fraction of the total breadth of the ADAAG, which not only reiterates the complexity of the law itself, but the clear strides still needed for equal access for patients with disabilities in the United States.

## **Problem Statement**

Patients with disabilities are less likely to participate in preventative care services and list physical access barriers as one of the many reasons (Pharr & Bungum, 2012; George & Mosqueda, 2008). Research suggests that outpatient health care facilities are often not compliant with relevant items from the ADAAG and that building age and administrative knowledge are the most reliable indicators of overall accessibility. This study proposes to research this topic in the context of rural West Virginia to test what is known in a rural setting and better understand the role retrofitting plays in the accessibility of healthcare facilities. West Virginia has a high percentage of people living in rural places (38%), and per capita, has the highest rate of citizens with disabilities making it a relevant option for this research. Using the OHCUP, a tool designed to measure baseline accessibility in health care facilities, the study will explore access barriers at ten sites and some of the correlating factors identified in literature (Drum, Horner-Johnson, & Walsh, 2012).

## **Purpose of Study/ Research Questions**

The purpose of the study was to better understand the usability of outpatient primary health care clinics in rural West Virginia. The study objective is guided by the following research questions:

- (1) How usable (or accessible) are rural primary health care clinics in West Virginia?
- (2) Which barriers to access are most commonly found in surveyed rural health clinics?
- (3) What is the extent of the relationship between building characteristics (such as age, original purpose and administrative knowledge) and usability profile, if any?

In addition, the research aims to inform participating clinics of their usability profile, and inform the West Virginia Clinical and Translational Science Institute (WVCTSI) and the West Virginia Practice-Based Research Network (WVPBRN) of the general findings. All participating clinics in this research are members of the WVPBRN.

## CHAPTER II

### **Review of Literature**

#### **Introduction**

There is a disparity between the level of health care received by people with disabilities in the West Virginia and the United States in general (Pharr & Bungum, 2012). Although the ADA guarantees equal access for patients with disabilities, health care facilities still struggle to eliminate barriers to access (Graham & Mann, 2008). With rural West Virginians reporting a high level of perceived access barriers it is important to understand how usable health care facilities are for patients with disabilities and where they can improve (Groins et al., 2005). The purpose of this study is to better understand the accessibility (usability profile) and correlating factor contributing to the lack usability among outpatient health care facilities in rural West Virginia.

#### **Barriers to Access**

The principal focus of public health research and promotion is to prevent disability and disease. This concept logically leaves research for the already disabled just a step behind. In an effort to become more inclusive when discussing public health it is necessary to realize that ‘prevention’ has different connotations for people with, and without, disabilities. The aim of public health, as it pertains to patients with disabilities, focuses on prevention of secondary conditions and the promotion of healthy lifestyle choices directly or indirectly related to their already existing condition(s). Rimmer and Braddock (2002) sought to make this distinction upon

realization of a gap and subsequent emerging topic in public health: health promotion for people with physical, cognitive and sensory disabilities.

Patients with disabilities are as much members of the constituency as anyone in the public health realm and the way in which they receive care has become a primary topic in research and design. Identifying problems and solutions for barriers of all types as well as the emergence of buzzwords like “patient-centered” and “universal” design are revealed throughout academia (Kirschner, Breslin & Iezzoni, 2007). Unfortunately, structural, societal, and policy change does not occur in step with research interest and today we still find ourselves in the discovery phase of improvement. Regardless, discovery is important and plays a role in creating awareness, particularly among consumers and providers. This section will highlight the perceived barriers of access for patients with disabilities and how those perceptions align with actual findings within health clinics themselves.

Pharr and Bungum (2012) found that although people with disabilities are more likely to participate in risky health behavior and report chronic disease, they are less likely to participate in preventative care practices. This is due to a number of perceived and actual barriers that vary in importance based on individual needs and situations. General barriers most commonly fall into an environmental, systematic, or structural category. Environmental barriers consist mostly of transportation barriers (including associated costs); systematic barriers consist of communication barriers between insurance and health care providers, and structural barriers consist of physical accessibility within the clinics themselves.

Identifying a primary barrier is difficult and varies when controlled for a multitude of factors (Iezzoni, 2002). General rural patients often cite environmental (transportation) factors

as a primary deterrent (Goins, Williams, Carter, Spencer & Solovieva, 2005). Among people with disabilities systematic issues like communication, and administrative knowledge and attitude are often cited in focus group discussions (Mattingly & Edwards, 2012; Morrison, George, & Mosqueda, 2008). One study, which surveyed both patients with disabilities and providers, found a lack of knowledge among providers and consequent communication errors as very frustrating to both parties. One patient said, "...I don't want to inform my own doctor...or teach someone. Like, why don't I just go to medical school myself?". Interestingly, a doctor in the same study said, "the biggest teachers have been patients" when asked about taking care of people with different disabilities (Mattingly & Edwards, 2012).

The principal focus of this research is structural barriers. According to Morrison, George, and Mosqueda (2008), physical barriers are a chief concern for patients with disabilities. In their qualitative research participants identified disability parking, wide automatic doors, large rooms, high-low tables, wheelchair scales, and lifts all as priority items on a 'wish list' of accessibility features in a health clinic. One participant said:

Unfortunately, I'm having gynecological problems, and they just look down there and say, 'Okay,' and they don't want to take the time to get me up on the table....How come they don't have tables that can lower...so that they can have a good look and diagnose you properly and accurately?

These same physical barriers are confirmed as consistent issues in papers by Sheer, Knoll, Neri and Beatty (2003) and Story, Schwier and Kailes (2009).

These same issues are often confirmed in quantitative research as well. In a random study of forty Midwestern clinics, research found that although health care administrators overwhelmingly stated that their clinics were accessible for patients with disabilities, a follow up

visit found this to be often untrue. Only 17.5% had height adjustable exam tables. Though less common, many issues were found in parking lot accessibility and a variety of issues were found in bathroom and hygiene accessibility including hand washing being problematic in 20% of clinics and bathroom stalls being compliant only in 62.5% of clinics (Sanchez, Byfield, Brown, Lafavor, Murphy & Laud, 2000).

A study of 62 Texas clinics using a 57-item ADA questionnaire found that a substantial portion of primary care physicians' offices were not in compliance with the ADA and that informational tools would be beneficial in educating physicians and administrators on nondiscrimination (Grabois, 1999). That study also found that 18% of primary care physicians in the study were unable to serve patients during the past year due to disabilities and that 22% had referred patients with disabilities to another clinic. A study of 68 primary care clinics in South Carolina using a modified 93-item tool found the average level of accessibility to be 70.3%. That same study found that "Key aspects of accessibility that were often lacking included car and van-accessible parking, lever door handles, clear floor space and grab bars in the restroom, TTY telephone or a hearing aid-compatible telephone, wheelchair accessible scale, and an adjustable-height examination table." (Graham & Mann, 2008, p.209). Finally, research done in California involving 2389 clinics and a 55-item accessibility tool found almost identical results; notably, only 3.6% of facilities had accessible weight scales and 8.4% has height adjustable tables (Mudrick, Breslin, Liand & Lee, 2012).

These physical access barriers have led to a wide range of implications. Women with disabilities report difficulty in finding facilities willing to accommodate pregnant women with mobility-related infirmities (Chan et al., 1999). Also, women with disabilities report having far

fewer preventive health screenings such as pap tests and mammograms (Earle & Church, 2004). Among men, one study found that the disabled were 19% less likely to receive PSA screenings for prostate cancer (Farmer, Grant, Papachristou, & Ramirez, 2001). Men and women with disabilities are less likely to receive height measurements, cholesterol tests, tetanus shots, and teeth cleaning (Armour, Swanson, Waldman, & Perlman, 2008; Haverkamp et al., 2004; Iezzoni, 2000). As a result of a lack of preventative care, people with disabilities are significantly more likely to rate their health as poor and to report dissatisfaction with their health care provider (Iezzoni et al., 2002).

### **Predicting Barriers to Access**

A study aimed at predicting accessibility barriers found a few key correlations. The study most notably found that buildings built before 1993 were the strongest indicator of the level of ADA compliance; but also found the administrator's ADA knowledge to be another leading factor. While 92% of administrators could describe the ADA generally, only 41% knew the consequences of non-compliance, 23% knew about tax credits to bring medical offices into ADA compliance, and 22% knew which title of the ADA applied to his/her medical offices (Pharr & Chino, 2012). Of facilities demonstrating the lowest levels of compliance, the leading cause was cost, and unfamiliarity with the problem. Many facilities claimed a lack of a need for improvements and opted to 'manage without' until the cost could be justified (Pharr, 2013).

### **State of Public Health in West Virginia**

Health outcomes in West Virginia are generally poor and more than often rank among the worst in the country. According to Americas Health Rankings website, West Virginia ranks worst among all states in drug deaths, obesity, smoking, diabetes, and premature death. In



addition, West Virginia has some of the highest rates of preventable hospitalization and occupational fatalities. Finally, West Virginia has the highest rate of citizens with disabilities with 8.9% of the population receiving some form of disability benefits. There is a lot to unpack when discussing public health in West Virginia, the most relevant for this research is the relationship between occupational fatalities and disability rates (America's Health Rankings, 2019).

According to research by Leigh and Fries (2011), occupational safety and health play a large role in predicting populations with disabilities. They concluded that fields such as general labor, farm work, machinery maintenance work, mining, and transportation have the highest level of disability (Leigh & Fries, 1992). In West Virginia, the non-farming workforce consists of 751,600 employees. Of that 133,100 work in trade, transportation and utility, 46,600 work in manufacturing, 33,800 work in construction, and 22,500 work in mining.

These fields make up 31.4% of the workforce (US Bureau of Labor Statistics, 2019). Nationally, West Virginia ranks relatively low in blue collar jobs per capita at 33rd (Center Research, 2019). This is true because blue collar jobs are in a steep decline in the state. Manufacturing has lost 35,000 jobs between 1990 and 2016 and mining jobs shed 13,000 positions in the same timeframe. In 1990, manufacturing made up 13.1% of the economy and mining made up 5.4% of the economy, today

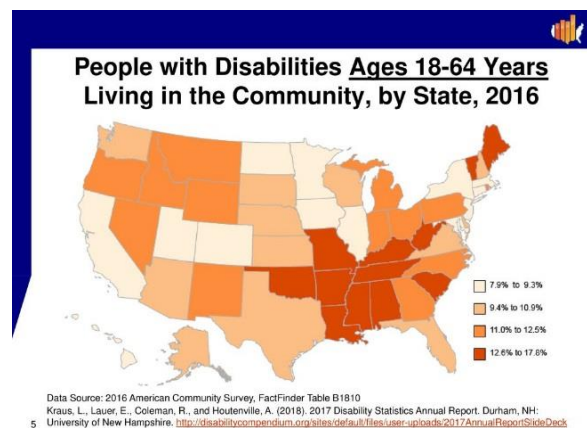

Figure 1: People Living with Disabilities in the US

those numbers are 6.1% and 2.7% of the economy, respectively. Interestingly, the largest gains in sector growth came from health care and social assistance jobs (Bump, 2017).

Although blue-collar jobs in West Virginia are declining and health care related jobs are increasing, it is important to note that West Virginia has one of the oldest populations in the country ranking 3rd in states with citizens above 65 years old (Burton, 2019). While age in general positively correlates with disability rates, it is important to realize that occupational effects on aggregate disability in the state remain even as blue-collar work declines.

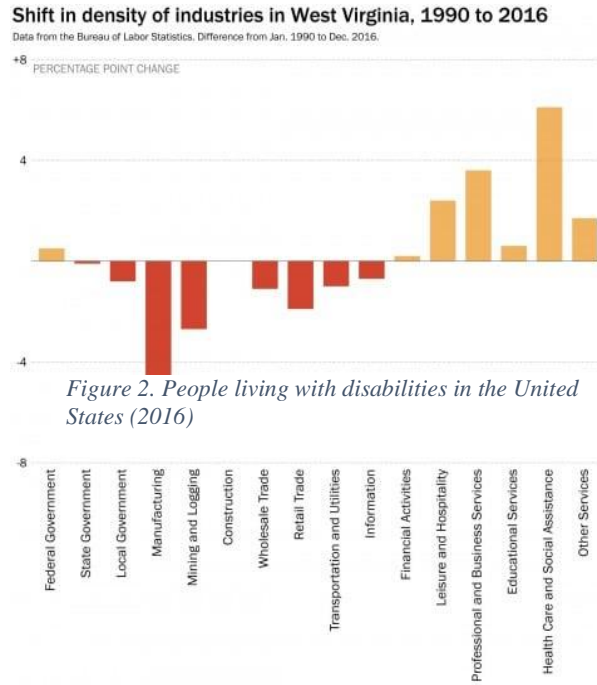

Figure 2. People living with disabilities in the United States (2016)

Figure 2. Shift density of industries in West Virginia (2016)

### Rural Access to Care

According to the Rural Health Information Hub (2019), 38% of the state of West Virginia’s population lives in rural areas and there are 50 rural health clinics and 232 Federally Qualified Health Center (FQHC) sites located outside of urbanized areas within the state (Rural Health Info, 2017). For rural patients, distance is identified as the most important barrier for receiving health care. This is true even though minimum travel time to be considered a barrier varies from patient

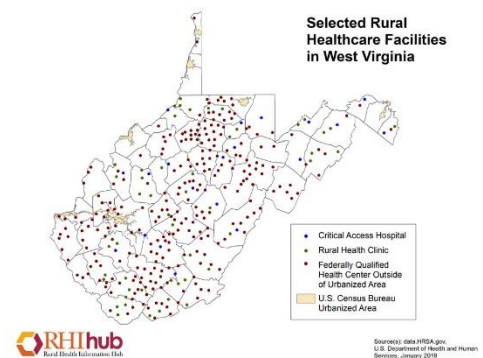

Figure 3: Rural Healthcare Facilities in West Virginia

to patient and is affected by various factors like health, socioeconomic status, and complexity of services needed (Buzza, Ono, Turvey, Wittrock, Reddy & Reisinger, 2011). Rural residents travel two to three times further on average to seek medical treatment (Rural Health Info, 2017; Chan, Hart, & Goodman, 2006). Being that access to medical treatment is less available to rural patients, there is an added emphasis to quality care at more remote sites.

### **The ADA as an Attempts to Address Disparity**

Measures in addressing discrimination and disparity among the disabled have been ongoing since the early 1970s and have culminated in the passing of the ADA in 1990 by addressing discrimination in the workplace, then moving on to equal access to government buildings, and finally ending with guaranteeing access to all public facilities. In order to achieve this, the ADA required all new buildings to conform to the ADA Accessibility Guidelines (ADAAG) which currently consists of over 700 technical requirements. Under the law, facilities are required to be in full compliance of the ADA; that, however, is often not the case for buildings that predate the passing of the law. For existing facilities, the ADA developed the Readily Achievable Barrier Removal Checklist, which brings attention to areas most pertinent to accessibility (The History of Americans with Disabilities Act, 2017; Drum, Johnson, & Walsh, 2012).

For facilities demonstrating non-compliance, the Department of Justice (DOJ) takes an as-needed approach through patient-facility mediation and litigation. Ultimately, the burden of enforcement falls solely on patients. Patients that feel facilities are in non-compliance must demonstrate that the existing facility presents an architectural barrier prohibited by the ADA and that removal of the barrier is readily achievable. Generally, complaints reviewed by the DOJ are

addressed through mediation attempts. If either party is unable to come to a resolution the plaintiff may seek justice through litigation. The DOJ may also file a suit if they feel the situation is precedent setting. This system is only so effective and does not ensure every instance of non-compliance is addressed. This is true because patients may not be aware of the proper procedure or even be interested in the long, complicated process of litigation only fix the problem after the fact. In addition, legal action threatens the patient-doctor relationship and in instances where health care facilities are few and far between any actions to disrupt that relationship may prove disadvantageous. As a result, between the years of 2000 and 2010, there were only 36 ADA enforcement settlements disclosed by the DOJ (Mudrick & Shwartz, 2010). An underwhelming amount of court cases may lead one to believe that ADA compliance isn't an issue; however, research cited above indicates that patients not only perceive accessibility barriers but state research supports their perceptions.

### **OHCUP and Other Evidence-based Efforts**

The Outpatient Health Care Usability Profile was designed by Drum, Johnson, and Walsh (2012) in coordination with the University of New Hampshire and University of Oregon. They concluded that the complexity and length of the ADAAG may be discouraging administrators of primary care sites to seek greater accessibility. Their solution was to design the OHCUP as an evidence-based tool to measure the usability of health care facilities. In contrast to the ADA Readily Achievable Barrier Removal Checklist, which pinpoints accessibility problem areas, the OHCUP is a valid, reliable and user-friendly tool that measures physical and environmental features of outpatient health care facilities, with a focus on essential features as opposed to full

ADA compliance. To our knowledge, none of the current ADA-based measurement tools were developed using validity and reliability testing.

An article out of the Journal for Patient Safety found that the inclusion of human factor expertise helps facilitate safe and efficient care (France et al., 2005). Evidence-based design has been used to develop a variety of valid and reliable health-based tools. The Craig Hospital Inventory of Environmental Factors (Whiteneck et al, 2001) was developed to measure environmental barriers for people with and without disabilities, the Community Health Environment Checklist (Stark, Hollingsworth, Morgan, Chang & Gray, 2008) was developed to assess disability barriers within the community. These tools used empirical research methods to evaluate the needs of people to aid in the development of accurate facility assessments.

Although a review of the literature reveals a high number of studies researching patient perception of accessibility barriers, there are a surprisingly low number of studies assessing the accessibility of actual facilities and none assessing national accessibility. One study, of which was previously cited, took place in South Carolina and found facilities to be 70% accessible on 93 ADAAG items assesses (Graham & Mann, 2008). A similar study in California assessed 55 ADAAG items (Mudrick, Breslin, Liang, & Yee, 2012). These studies yielded similar results of low accessibility in the areas of parking/ drop off, height adjustable tables, fully accessible restrooms, and wheelchair accessible scales. When compared to tools used in previous studies, the OHCUP is slightly more robust, consisting of 159 items.

In conclusion, barriers to access still widely exist for patients with disabilities. Perceived physical access barriers for patients with disabilities are consistent with quantitative research of medical clinics on a state-wide level. These barriers play some role in the quality and quantity of

preventative care received. This type of research is relevant in West Virginia where disability rates are high and many people live in rural places. The lack of primary care clinic options for rural populations places an added emphasis on quality for those clinics. Current efforts to improve accessibility are not quickly or efficiently solving the problem so academic research and abbreviated tools are being developed to create change and awareness. Accessibility statistics are largely unavailable in West Virginia and research is needed not only to better understand our usability profile but to be able to predict where gaps are likely to exist.

## CHAPTER III

### Methods

#### **Purpose of Study**

This study aims to expand upon research in the realm of accessible design specifically for rural outpatient clinics in West Virginia. Generally, how usable are the evaluated rural sites, which items are commonly found in non-compliance, and which factors are the strongest predictors of inaccessible sites? The research is guided by the following research questions:

- (4) How usable (or accessible) are rural primary health care clinics in West Virginia?
- (5) Which barriers to access are most commonly found in surveyed rural health clinics?
- (6) What is the extent of the relationship between building characteristics (such as age, original purpose and administrative knowledge) and usability profile, if any?

The researcher also seeks to explore how the overall findings compare to similar research. Research out of South Carolina which found surveyed clinics were 70% accessible using a 93-item tool. Additional research out of Texas (Grabois, 1999), California (Mudrick, Breslin, Liand & Lee, 2012), and South Carolina (Graham & Mann, 2008) found common non-compliance issues in bathrooms, parking lots and exam rooms, including a lack of wheelchair accessible scales and height adjustable tables.

#### **Research Design**

The research uses a quantitative design utilizing two tools in clinical evaluation, the Outpatient Health Care Usability Profile (Drum, Horner-Johnson & Walsh, 2012), and a self-developed survey, to answer descriptive and correlative research questions. The OHCUP tool is

as a valid and reliable tool that can be completed between one and two hours and produce categorical (overall, Mobility, Sensory and Cognitive) results as well as sub-categorical and individual results that are easily compared with similar research. The survey questions were designed to understand the age and purpose of the building that house the clinic as well as the administrator's knowledge of the ADA in general and Title III of the ADA specifically. Parameters for sample sites included health care facilities that were both rural and offer outpatient primary care and were identified in coordination with the WVPBRN. This research design was approved by the West Virginia University Institutional Review Board (IRB), protocol number 1802995833.

## **Sample**

Ten rural outpatient primary health care sites in West Virginia participated in the research study from September to November of 2018. The WVCTSI helped obtain the sample, which are all member sites of the WVPBRN. The WVPBRN's mission is to improve the health of West Virginians by collaborating with primary care practices to conduct translational practice-based research. The WVPBRN approved the research design allowing access to 94 primary care sites in West Virginia. Purposive sampling was used to select eligible sites. Participating sites were rural, diverse in terms of their health care system, and offered outpatient health care services.

The research used the RUCA codes 7.0 through 10.0 to define rural locations. RUCA codes rate every US census block on a scale from 1.0 (urban) to 10.0 (rural) based on population density, commuting distance, and proximity to major roads. RUCA codes offered a more refined definition of metro and micro areas as county-wide data is often considered too large to delineate areas with populations below 10,000. RUCA codes have been widely adopted for research and



policy applications, especially in rural health (Cromartie & Bucholtz, 2008). Selected sites were to have RUCA codes between 7.0 and 10.0 which Skillman, Palazzo, Keepnews, and Hart (2006) consider “small rural” areas. The USDA defines primary RUCA code 10 as “rural,” 9 as “small town low commuting,” 8 as “small town high commuting,” and 7 as “small town core” (USDA, 2016).

Of the twenty WVPBRN sites that met the inclusion criteria, ten ultimately chose to participate. All sites were independently owned or members of various and diverse health care systems with the exception of two facilities which were owned by the same healthcare system. Participating facilities received their results within one week. The location and name of each participating site are kept confidential as legally possible and data are reported in aggregate.

## **Measurement Tools**

### *Survey*

The goal of collecting survey data ultimately served as a basis for understanding the characteristics of the facility. Questions also collected demographical data on the chief administrative member asked to complete the survey and also included a short ADA knowledge portion. The original intent of the knowledge portion of the survey was to investigate previous research that concluded that administrative knowledge positively correlated with clinical accessibility scores. The survey overall served to primarily aid in investigating the relationship between accessibility scores and approximate age of the building, the original purpose of the building, and relevant ADA knowledge of the administrator.

The survey consists of previously validated questions used in peer-reviewed articles: *Accessible medical equipment for patients with disabilities: Why is it lacking?* (Pharr, 2013) and *The Americans With Disabilities Act Knowledge Survey: Strong psychometrics and weak knowledge* (Hernandez, Keys & Balcazar, 2003). The latter served to formulate questions regarding building characteristics and demographical data and the former served to formulate questions regarding ADA knowledge. The language used reflected that of two surveys, except for added instructions to select from a dropdown menu and in one case where participants are prompted to select a decade in which their facility was built as opposed to providing a specific year. This is in consideration of administrators who are unaware of the specific year of construction. In addition, the ADA knowledge survey is refined to only reflect questions referencing the ADA in general and ADA title iii which prohibits discrimination based on disability in places of public accommodation, the section most related to outpatient health care sites (Americans with Disabilities Act, 1990). The ADA knowledge survey originally categorized questions by title i, ii, iii, and general.

Administrators from all 10 locations completed surveys. Participants were permitted to skip any questions which they did not wish to answer. All participants answered questions relating to their demographic and respective building characteristics; however, only three participants elected to complete the knowledge portion of the survey, resulting in elimination of the section during analysis.

#### *Outpatient Health Care Usability Profile*

The primary tool used in gathering data is the Outpatient Health Care Usability Profile which is a tool designed by researchers from the Oregon Health & Science University and

published in the Disability and Health Journal (Drum, Horner-Johnson & Walsh, 2012). The objective was to “develop a valid, reliable, and user-friendly tool that measures the physical and environmental features of outpatient health care facilities.” These researchers cited a need for such a tool in response to the length and difficulty of using the ADA Accessibility Guidelines (ADAAG) which contains over 700 technical requirements. They noted that a number of authors suggested that the guidelines were complex and not user-friendly. They also claim that to their knowledge no ADA-based measurement tools are developed using validity and reliability testing. Their measurement tool would address the need for a valid and reliable user-friendly tool by seeking out the “essential features” necessary for a health care facility to provide services for a person with disabilities. Compliance with these essential features measures the “usability” of particular facilities.

A quantitative research design was employed in data collection. An online survey was developed to obtain data about priority areas in health care access. Results confirmed substantial barriers to health care access for people with disabilities and that accessibility needs varied among different disability groups. Groups were categorized into barriers for patients of specific functional categories of disability: Mobility, Sensory, and Cognitive. Three work groups from Portland Oregon were recruited to represent each of these categories and were tasked to rate related ADAAG items as “important,” somewhat important,” and “not important.” Results were reviewed by six ADA subject matter experts from ten regional ADA technical assistance centers and asked to review each item to determine if items were essential to the usability of an outpatient clinic by people with physical, sensory, and cognitive disabilities. The rating was done independently and summarized as Content Validity Ratios. Retained items were organized

into a 3 section pilot tool. Items included a “yes,” “no,” and a “not applicable” response. Pilot testing was conducted by two different raters at 10 outpatient health clinics in Portland, Oregon using a range of practice sizes. Inter-rater reliability was tested using Cohen’s Kappa and was assessed using Cohen's Kappa coefficient and Gwet's AC1 statistic. Based on the results of the pilot test, items were refined to reduce technical language and ambiguity. Graphics were added to further clarification. Ten new sites were sampled and items with persistently low inter-rater reliability were further refined. A final test was conducted using nine new facilities and found inter-rater reliability of 0.89 (Cohen’s Kappa) and 0.97 (Gwet’s AC1).

A final version of the tool consists of 159 items which takes approximately one hour to complete. The tool scores each item with a 1, which means the item either received a “yes” in terms of meeting the ADA guideline criteria or a “not applicable” meaning the item did not apply to the facility, or a 0, which means the item received a “no” in terms of meeting the guideline criteria. Scores are calculated in the final section of the tool as a percent value for overall score (159 items), Mobility score (129 items), Sensory score (41 items), and Cognitive score (8 items) (Drum, Horner-Johnson, & Walsh, 2012).

## **Procedure**

Administrators at participating sites were e-mailed a link to the survey. The WVPBRN facilitated communication with each facilities administration to ensure each site finished the survey before being visited by the researcher for further evaluation using the OHCUP tool and scheduled a date and time for the evaluation. Upon arrival at the research site, the researcher met with the administrator to ensure appropriate access was granted and that any site-specific protocol was met while evaluating the location. This included actions such as obtaining a visitor

pass, being assigned a property guide, and receiving and communicating general restrictions related to access and/or patient-related privacy regulations. Each administrator was informed of the access needs which consisted of the parking lot, the waiting room, restrooms, stairs/ elevators, hallways/ emergency egress areas, lab specimen rooms, and exam rooms. OHCUP is categorized into three sections: Patient Arrival, Public Facilities, and Exam Rooms and access to Primary Services.

Four tools are required to conduct the OHCUP: pen/ pencil, measuring tape, a tool for determining slope, and a door pressure gauge. The researcher checked “Yes,” “No,” or “N/A” with a writing utensil on a physical copy of the OHCUP and took notes used for clarification of results and to share with the administrator at the conclusion of the evaluation. A measuring tape is most commonly used during the evaluation in measuring OHCUP accessibility items. The researcher used an iPhone application to measure the slope of ramps. A door pressure gauge was purchased to measure pounds of pressure needed to open interior doors.

In the event that there are multiple options for evaluating the same features or rooms, by rule, the researcher evaluates that which is most easily and obviously used by patients. This is true for every item in Section 1: Patient Arrival and Section 2: Public Facilities with the exception of public restrooms in the event that clearly indicated the location of accessible restrooms in the building. For Section 3: Exam Rooms and access to Primary Services, the administrators were instructed to direct the researcher to the rooms which they considered most accessible.

The entire parking lot was evaluated and in the event that the facility shared a parking lot, a parameter was established with the help of administrators and/or property managers before the

evaluation took place. One main entrance was evaluated at each site unless the location of another accessible entrance was clearly indicated. One restroom was evaluated per waiting room. One lab specimen collection room was evaluated. Every waiting room, public passageway, water fountain, elevator, staircase, and lift were evaluated. To earn a “yes” in any of the items within these subcategories the requirements must be met at each location. For example, if an item is in compliance in one waiting room, but not in another waiting room the item receives a “no” rating. In order to maintain consistency, the researcher rounded to the nearest inch in measuring all items. So, if the item was less than .5 inches from the target requirement they received a “yes.” Anything exceeding that threshold received a “no.” This was done as a means of creating a pragmatic report for participating sites and more easily evaluate features with rounded and/or ambiguous edges. In the case that an item does not apply to the site the item is marked “N/A.” N/A items are counted as a 1 in scoring so all evaluations are out of 159 items and where an item does not apply to the site, they receive the benefit of the doubt.

A brief meeting concluded the evaluation to review items that may have been overlooked, particularly height adjustable tables, wheelchair accessible scales, vending machines, water fountains, public phones, etc. In addition, the researcher reaffirms confidentiality by limiting access to the results to the research team and the facility administrator. All other data are reported in aggregate. The administrator is informed that they will receive a full report of the results within one week. Evaluation reports consisted of a score in each category (with the exception of an additional N/A adjusted category which is discussed below), notes on each item that received a “no” describing why the standard was not met, and how their score compares to average scores based on a review of literature.

## Data Analysis

In addition to the four categories initially evaluated using the OHCUP (overall, Mobility, Sensory, and Cognitive), the researcher produced a fifth evaluation category for data analysis: N/A adjusted score. This score eliminates any items marked “N/A” in the initial research and calculates the new score using only “yes” and “no” responses. This allows for a more consistent comparison to other research (Graham & Mann, 2008) which only allow for “yes” and “no” responses and where items are not applicable, they are not included in the final results.

The aggregated mean for all facility scores in the five major categories were used to assess the usability of the health care clinics. Results from each section of the OHCUP were calculated in aggregate to better understand more specific areas of noncompliance. Specific items were also aggregated and discussed in terms of commonly noncompliant items. Sections, subsections, and specific items were compared to similar studies in the discussion portion of this thesis.

The relationship analysis measured the correlation between all five final OHCUP scores and approximate building age as well as how the OHCUP scores were affected by the original purpose of the building. Approximate age was determined by the midpoint of the decade in which the facility was built. Shapiro-Wilks W test were used to assess the distribution of all of the factors. Relationships of normally distributed variables were analyzed using parametric correlations (Pearson  $r$ ) and variables including data that is not normally distributed were analyzed using nonparametric correlation (Spearman’s  $\rho$ ). In measuring the effect building purpose has on OHCUP scores a t-test were used for parametric data using Oneway analysis and

a nonparametric Wilcoxon test were conducted for data with variables that were not normally distributed.

Data were analyzed using JMP and SAS software (JMP®, Version Pro 12.2, SAS Institute Inc., Cary, NC, Copyright ©2015; SAS®, Version 9.3, SAS Institute Inc., Cary, NC, Copyright ©2002-2010). Significance criterion alpha for all tests was 0.05.

In all statistical analyses, significance criterion alpha for all tests was 0.05 and a statistical trend was declared when  $p < 0.1$ .



## CHAPTER IV

### Results

#### Demographic and Survey Results

Nine administrators were surveyed because one participant served as administrator for two surveyed facilities. The administrator was asked to answer the survey questions keeping the separate facilities in mind and all other survey respondents were from distinct, rural health care systems from across the state of West Virginia.

The following questions pertained to the administrative experience of each respondent. In terms of educational attainment, two respondents held Bachelor's Degrees, seven held Master's Degrees, and one held a Doctoral or Professional Degree. When asked how many years of experience each respondent had in health care administration seven responded with 1-5 years, two responded with 6-10 years, and one responded with 20+ years. When asked about years serving as an administrator at current practice five responded with less than one year, two responded with 1-5 years, two responded 6-10 years, and one responded 20+ years.

In addition, five questions were asked to determine the demographical building characteristics of each facility. The results show that in terms of year of construction two facilities were built before 1950, one was built between 1950 and 1959, two were built between 1980 and 1989, one was built between 1990 and 1999, three were built between 2000 and 2009, and one was built between 2010 and 2018. Seven facilities were built for the purposes of housing a medical practice and three were not. Eight practices were independently owned and two identified as a branch of a larger organization. When given the option to elaborate two noted that they were

Federally Qualified Health Care (FQHC) sites, and two mentioned the specific organizational owners, which were the same entity. When asked to identify their specific type of practice, administrators were informed that they may choose multiple selections from a list and/or write in a response. Thirteen responses were recorded. Six selected Doctor's Office, one selected General Outpatient, one selected Specialist Clinic, and one selected Hospital. Four responses were written in: Primary Care and Pediatrics, Primary Health Care and pediatrics, hospital with an RHC (Rural Health Clinic) and FQHC, and Community Health Center. The survey also included a section on knowledge in which only three administrators opted to participate. This resulted in the removal of this section for statistical analysis.

Table 1

Demographic Characteristics of Administrators Participants (n = 10)			Building Characteristics	
	n	%	n	%
<b>Education</b>			<b>Decade built</b>	
Bachelor's Degree	2	20	2010 – 2018	1 10
Master's Degree	7	70	2000 – 2009	3 30
Professional Degree	1	10	1990 – 1999	1 10
			1980 – 1989	2 20
<b>Years of administrative experience</b>			1970 – 1979	0 0
Less than 1 year	0	0	1960 – 1969	0 0
1-5 years	7	70	1950 – 1959	1 10
6-10 years	2	20	Earlier than 1950	2 20
11-15 years	0	0	<b>Independently owned</b>	
16-20 years	1	10	Yes	8 80
20+ years	0	0	No	2 20
<b>Years at current practice</b>			<b>Type of practice</b>	
Less than 1 year	5	50	Doctor's Office	5 50
1-5 years	2	20	Specialist Clinic	1 10
6-10 years	2	20	Hospital	1 10
11-15 years	0	0	General Outpatient	1 10
16-20 years	0	0	<b>Originally built to house medical offices</b>	
20+ years	1	10	Yes	6 60
			No	4 40

## **OHCUP Organization**

OHCUP is designed in a way to produce several major categorical and sub-categorical results. Major categories include Mobility, Sensory, Cognitive and overall score for each facility. In addition, an N/A adjusted score was calculated in order to produce a result more easily compared with the results of similar research. Sub-categories include parking, building approach, ramps, signage, controls, doors, telephones, seating, counters, passageways, lifts, elevators, stairs, restrooms, toilet stalls, toilet rooms, emergency egress, exam rooms, and lab specimen rooms. (Note that restrooms and toilet rooms/ stalls are the same room but fall into separate categories based on the type of restroom. The toilet room/ stall section is a brief extension of the restroom sub-category that pertains to particular ADAAG items relating to specific characteristics. A restroom is either a toilet room or a toilet stall.) Results are reported by aggregating the mean of all facilities in the respective category. Within each subcategory are relevant, individual items taken directly from the ADAAG. Scores are calculated by dividing the total number of items marked “Yes” or “N/A” divided by the total number of survey items pertaining to the category. This is with the exception of N/A adjusted scores which remove any results marked N/A entirely.

### *Major categorical results*

On average, facility Mobility scores were usable on 82.98 (SD = 7.57) of items measured with a range from 66.94 to 95.04. This is out of 121 Mobility related items. The mean Sensory score was 84.14 (SD = 0.60) with the minimum score recorded at 70.73 and the maximum score recorded at 92.68. This is out of 41 Sensory related items. The average Cognitive score was 86.35 (SD = 1.60) of 8 related items with a range from 62.55 to 100.00. Overall facilities

averaged 83.08 (SD = 6.23) usable for people with mobility, sensory, or cognitive disabilities with a range from 70.44 to 93.71.

When items marked N/A were not included the results were considerably lower. The average of the N/A adjusted score was 73.40 (SD = 9.90) with a range minimum of 52.00 and a maximum of 89.00. By adjusting for N/A

the total number of items removed from calculation was 576 or 36.23 percent of the total item evaluated in every facility. The mean total of items each facility was evaluated on was 101 after items scored N/A were removed. When inapplicable items were removed the mean score for Mobility was 73.49, Sensory was 69.86, and Cognitive was 81.97.

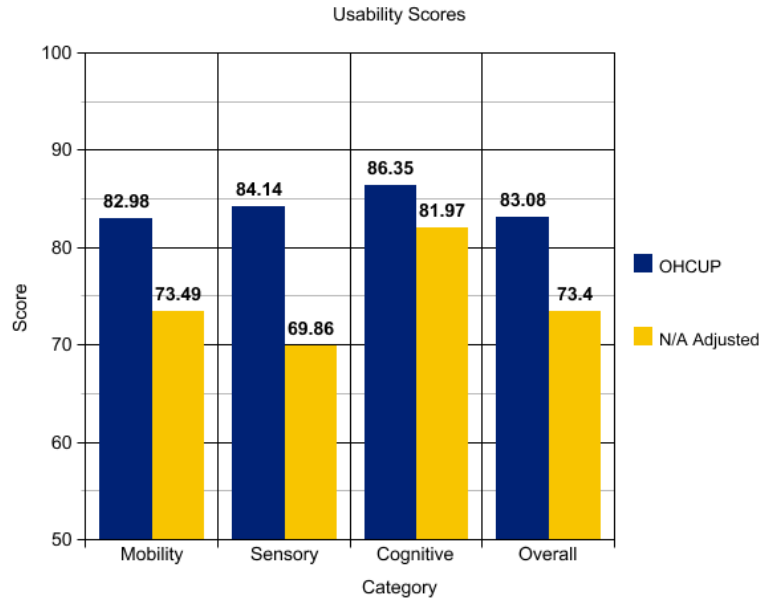

Figure 4: Usability Scores

#### *Sub-categorical results for Overall Score*

Sub-categorical results include 19 categories. Each sub-categorical score can be found in Table 2. The results below are not N/A adjusted, meaning that in the instance that an item did not apply to a particular facility they received the point by default. This can result in misleading scores when a sub-categorical results are high because of high levels of inapplicability in a certain sub-category. For example, telephones, lifts, and toilet stalls each scored an average of 100.00, but none of these items were applicable to any of the ten sites sampled. These three sub-

categories are the only examples of total inapplicability at every location; however, the total number of evaluated items is important in every instance. Because of this another table indicating N/A Adjusted scores in each category is also evaluated. In the table below, the number of evaluated items in all facilities after N/A scores are removed is indicated in parenthesis. This can be compared with the column indicating the total number of items evaluated to indicate how many items are removed in the Table 2. The table to the right includes all sub-categories featured in the OHCUP, the number of ADAAG items featured in each subcategory, the total number of items evaluated when multiplied by the ten evaluated sites, the total number of those which were found in compliance (including those

Table 2

*Sub-Categorical Results (Not adjusted for inapplicability)*

<b>Sub - Category</b>	<b># of Items in Subcategory</b>	<b>Total # of Items Evaluated (N of facilities * N of Items in subcategory)</b>	<b>Total # of Items in Compliance</b>	<b>%</b>	<b>CI 95% Lower and Upper for Sub-Categorical Compliance</b>
<b>Counters (13)</b>	2	20	11	55.00	32.05 – 76.17
<b>Lab Specimen Rooms (199)</b>	24	240	170	70.83	64.57 – 76.41
<b>Restrooms (181)</b>	20	200	142	71.00	64.10 – 77.08
<b>Exam Rooms (89)</b>	9	90	66	73.35	62.80 – 81.86
<b>Signage (98)</b>	13	130	97	74.61	66.09 – 81.70
<b>Parking (56)</b>	7	70	54	77.14	65.27 – 85.99
<b>Seating (20)</b>	2	20	16	80.00	55.73 – 93.38
<b>Doors (64)</b>	7	70	59	84.29	73.19 – 91.52
<b>Controls (20)</b>	2	20	17	85.00	61.14 – 96.04
<b>Toilet Rooms (12)</b>	3	30	26	86.67	68.36 – 95.64
<b>Ramps (23)</b>	6	60	55	92.00	80.88 – 96.90
<b>Fountains (12)</b>	3	30	28	93.33	76.50 – 98.83
<b>Elevators (26)</b>	13	130	122	93.85	87.84 – 97.11
<b>Approach (71)</b>	10	100	94	94.00	86.89 – 97.54
<b>Passageways (49)</b>	7	70	67	95.71	87.16 – 97.11
<b>Stairs (16)</b>	5	50	48	96.00	85.14 – 99.30
<b>Toilet Stalls (0)</b>	5	50	50	100.00	91.11 – 99.30
<b>Lifts (0)</b>	6	60	60	100.00	92.50 – 99.85
<b>Telephones (0)</b>	7	70	70	100.00	93.51 – 99.87

receiving one point for inapplicable items), the aggregate percent score of those scored in compliance, and finally a confidence interval of those results as defined by Volsett (1993).

Categories that scored below the 83.08 Overall score average from lowest to highest score include counters, lab specimen rooms, restrooms, exam rooms/ access to primary care, signage, and parking. Counters included any table in which one exchanged general information with a facility employee and included only two items regarding height and knee space (in the instance that tables are used to exchange information. Counters averaged 55.00 (SD = 15.81) usable on items assessed with a range of scores from 50.00 to 100.00. All facilities used counters to exchange information and no instances of tables were used for the same purpose so all facilities received an N/A score (1 point) for the item regarding knee space.

Lab specimen rooms included rooms (alternative restrooms in every instance) with the primary purpose of collecting patient samples. Twenty-four items existed in the section although three were either/or items where only one item could be evaluated per facility leaving the maximum total number of items at twenty-two. All facilities evaluated had a lab specimen collection room. Lab specimen rooms averaged 70.83 (SD = 13.02) in terms of usability and scores ranged from 50.00 to 95.80.

Restrooms included location(s) which was/were most obviously accessible to the general public and/ or closest to the facilities waiting room except in the instance where a sign indicated the location of a handicap accessible restroom. In two instances there were multiple waiting rooms with multiply associated restrooms. In this case, points were only awarded if the items were in compliance at each location. No signs indicated the location of handicap accessible restrooms, although one location directed me to one upon request located in the back of the

facility. The restroom was evaluated for the benefit of the facility but not included in the scoring section. Twenty items were included in the evaluation of restrooms. Restrooms averaged 71.00 (SD = 14.29) usable and scores ranged from 50.00 to 90.00.

One exam room was evaluated at the direction of the facility administrator. Administrators were instructed to select an exam room that they considered most accessible or one they would choose given the opportunity to exam a patient with a disability. Nine items were included in the evaluation of exam rooms. This section also included items pertaining to access to primary care and contained items such as wheelchair availability, passageways to the exam room and availability graphic charts for people with disabilities. The mean usability score was 73.35 (SD = 17.52) with the minimum score being 33.33 and the highest score being 88.90.

Signage included those that directed patients to, and within, the clinic only and consisted of thirteen items. Signs not pertaining to directions to, and within, the clinic were evaluated in other sections. For example, handicap parking signs were evaluated in its respective section. Signage among all facilities averaged 74.61 (SD = 10.28) usable and ranged from a low of 53.85 to a high of 84.62.

Parking consisted of seven items applying only to the area within the immediate vicinity of the clinic. In the instance of a shared lot an agreed upon number of spots most closely associated with the clinic was determined with the administration or property manager before evaluation. This happened in three instances. The mean parking score of all facilities was 77.14 (SD = 20.42) with a range from 42.90 to 100.00 usable.

Finally, Seating consisted of two items applying to seating areas in the waiting rooms. The mean seating score was 80.00 (SD = 25.81).

In order to more fairly compare the data, all items that received an N/A were removed and re-evaluated. This table features the number of applicable items (indicated in parenthesis above) in the second column. The third column indicates the number of items in compliance out of the new total number of applicable items and is represented as a percent in the next column. The confidence interval is also featured in the table. Only items that fall below the mean N/A Adjusted score are featured in the table, indicating the sub-category is commonly found in non-compliance. So, since the mean of all N/A Adjusted Overall scores was 73.40%, all sub-categories falling below that threshold are included in Table 3.



Table 3

**Sub-Categorical Results (N/A Adjusted) (M < 73.40)**

Number of Facilities (N = 10)

<b>Sub - Category</b>	<b>Total # of Applicable Items</b>	<b>Total # of Items in Compliance</b>	<b>%</b>	<b>CI 95% Lower and Upper for Applicable Sub- Categorical Compliance</b>
<b>Counters</b>	13	4	30.76	10.36 – 61.12
<b>Lab Specimen Rooms</b>	199	132	65.34	59.25 – 72.77
<b>Signage</b>	98	65	66.33	55.99 – 75.37
<b>Toilet Rooms</b>	12	8	66.66	35.44 – 88.73
<b>Restrooms</b>	181	122	67.40	59.99 – 74.06
<b>Elevators</b>	26	18	69.23	48.10 – 84.91
<b>Parking</b>	56	40	71.43	57.59 – 82.31
<b>Exam Rooms</b>	89	65	73.03	62.41– 81.64

Similar to the initial results, items that fall below the mean 73.00 N/A Adjusted scores are listed as items commonly found in non-compliance. These sub-categories include counters,

lab specimen rooms, signage, toilet rooms, restrooms, elevators, parking, and exam rooms. All sub-categories featured in the first evaluation (not adjusted) are identified as highly non-compliant sub-categories in the N/A Adjusted evaluation with the exception of seating which remained at 80.00 since all items evaluated were applicable at every location. Elevators are the only item added to the list; however, only two locations evaluated featured Elevators. The research concludes that counter, lab specimen rooms, signage, toilet rooms, restrooms, elevators, parking, exam rooms, and seating are the most substantial problem areas within surveyed facilities.

#### *Individual items most commonly found in non-compliance*

The following section evaluates individual items within the OHCUP to understand which items are most commonly found in non-compliance among surveyed facilities. The table below details the number of facilities that were not compliant with a particular item. So, for example, if the table indicates a number “10” in the final row then all facilities surveyed were non-compliant for that corresponding item. Items that did not receive a point for usability/ compliance in half or more than half of the facilities surveyed are listed in the table. A full list of item compliance among all facilities is located in the appendix. Results indicated in the table are done using the Overall scoring method that is items that are marked “N/A” are counted as one point which is equivalent to a “Yes.” Eighteen items are detailed in the table in order of how they appear in the OHCUP. Sub categories that contained items most commonly found in non-compliance include parking, signage, doors, counters, restrooms, emergency egress, exam rooms/ access to primary care, and lab specimen rooms.

Table 4

*Individual Items Commonly Found in Non-compliance (>40%)*

<b>Sub Category</b>	<b>Item #</b>	<b>OHCUP Item Text</b>	<b># of Facilities in Non- compliance</b>	<b>%</b>	<b>CI 95% Lower and Upper for Item Non- compliance</b>
<b>Parking</b>	2	At least one in every eight designated parking spaces is van accessible.	6	60.00	49.70 – 69.52
<b>Signage</b>	29	Signs are mounted on the wall adjacent to the latch side of the door and outside the door swing.	5	50.00	39.90 – 60.10

	36	Sign is present at entrance to clinic at a height of 60 inches to centerline and features high contrast, raised and Braille characters, and non-glare finish.	10	100.00	95.40 – 99.90
<b>Doors</b>	41	There is at least 18 inches of clear wall space on the latch side of doors (to get in <b>and</b> out).	6	60.00	49.70 – 69.52
<b>Counters</b>	55	The tops of tables or counters are between 28 and 34 inches high.	9	90.00	81.97 – 94.84
<b>Restrooms</b>	91	Signs are mounted on the wall on the	9	90.00	81.97 – 94.84

latch side of the door, 60 inches from the floor to the middle of the sign.

97	The entry is large enough for a wheelchair user to enter, turn around and exit.	6	60.00	49.70 – 69.52
104	The highest operable part of all dispensers and hand dryers is no higher than 48 inches for a forward approach.	6	60.00	49.70 – 69.52
105	All dispensers and hand dryers are operable with a single closed fist (pull-down paper-	7	70.00	59.90 – 78.55

towel dispensers &  
 many seat-cover  
 dispensers are  
 usually not  
 accessible by this  
 criteria).

<b>Emergency Egress</b>	124	Where emergency alarms are provided, additional visual alarms are installed in general use areas such as meeting rooms, hallways, lobbies and restrooms.	5	50.00	39.90 – 60.10
<b>Exam Rooms/ Access to Primary Care</b>	129	There is a method to weigh a wheelchair-user.	6	60.00	49.70 – 69.52
	131	There is at least one lift or transfer	10	100.00	95.40 – 99.90

		device available for use in exam room.			
<b>Lab Specimen</b>	137	Signs are mounted	8	80.00	70.57 – 87.08
<b>Room</b>		60 inches to the centerline on the wall on the latch side of the door, out of the way of the door swing.			
	143	The entry is large enough for a wheelchair user to enter, turn around, and exit.	8	80.00	70.57 – 87.08
	150	The highest operable part of all dispensers and hand dryers is no higher than 48 inches.	6	60.00	49.70 – 69.52

151	All dispensers and hand dryers are operable with a single, closed fist.	7	70.00	59.90 – 78.55
152	The mirror is mounted with the bottom edge of the reflecting surface no higher than 40 inches.	7	70.00	59.90 – 78.55
155	There are at least 18 inches of clear space from the center of the toilet to the wall(s) on either side.	5	50.00	39.90 – 60.10

---

Compliant items in only half of the evaluated facilities included properly located signage (directing to and within the clinic), adequate number or type of emergency alarms, and adequate space on either side of the lab specimen room toilet. Only four facilities had adequate and/ or enough van accessible spaces, large enough restrooms, properly placed dispensers (restrooms



and lab specimen rooms), and wheelchair accessible scales. Only three facilities had dispenser and hand dryers that were operable with a closed fist (restrooms and lab specimen rooms), and a mirror that was mounted at the proper height. Compliant items in only two facilities evaluated included properly mounted signs or large enough space in the lab specimen rooms. Only one facility featured counters at the appropriate height and appropriately mounted restroom signs. Finally, no facilities featured adequate signs at the entrance of the building (including high contrast and raised lettering, braille, and a non-glare finish) and no facility featured a lift or transfer device for use in an exam room.

## Correlational Analysis for Approximate Age



Figure 5: Mobility score vs aprx. age

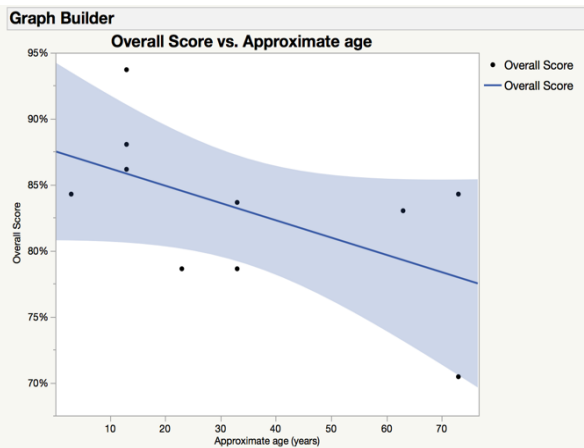

Figure 6: Overall score vs aprx age

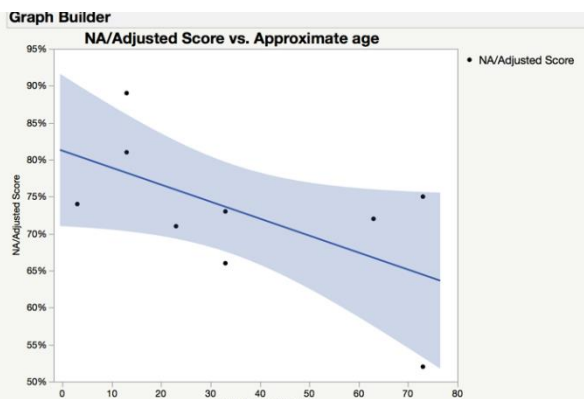

Figure 7: N/A adjusted vs aprx age

The research also aimed to understand if building age and original purpose correlate with facility usability profiles. Parametric correlations (Pearson  $r$ ) were done examining relationships of variables that were normally distributed (based on Shapiro-Wilk  $W$  test).

Spearman's Rho was used to evaluate correlations for nonparametric data which in this case include Cognitive scores. Since participants were only asked to identify the decade in which their facility was built the midpoint was used when analyzing correlational data. A Pearson correlation coefficient was computed to assess the relationship between approximate building age and Mobility, Sensory, Overall, and N/A adjusted scores of facilities.

Correlation between approximate building age and Mobility score was statistically significant and moderately negatively correlated [ $r = -0.662$ ,  $n = 10$ ,  $p = 0.037$ ]. A statistical trend was observed for Overall [ $p = 0.095$ ] and N/A

adjusted [ $p = 0.059$ ] correlations with approximate building age. Correlation between approximate building age and Overall score resulted in a moderately negative correlation [ $r = -0.555$ ,  $n = 10$ ]. Correlation between approximate building age and N/A adjusted score also resulted in a moderately negative correlation [ $r = -0.612$ ,  $n = 10$ ]. The Sensory score was not correlated with approximate building age. In order to test for correlation of nonparametric data, a Wilcoxon test was used for the relationship between the Cognitive category and approximate building age. The Cognitive score was not correlated with approximate building age.

## **T-Test for Medical Purpose Effect on Categorical Date**

### *Parametric Data*

When testing if the original purpose of the building affected categorical scores a t-test was conducted for parametric data including scores in Mobility, Sensory, Overall, and N/A adjusted scores. Of the facilities evaluated, seven were built for the purposes of housing a medical office; three were retrofitted to house a medical office. These results are interpreted with the caution of a small sample size. There was a statistical trend observed when comparing the means of the two groups that indicated N/A adjusted scores, Mobility score, and Overall score was higher for building built with the purpose of housing a medical office.

The mean for N/A adjusted score of buildings built for the purpose of housing medical offices was 0.7671 (SD = 0.076) and the mean of N/A adjusted score for retrofitted medical offices was 0.6566 (SD = 0.118);  $t(8) = 1.81$ ,  $p = 0.054$ . The mean for Mobility score of buildings built for the purpose of housing medical offices was 0.855 (SD = 0.060) and the mean of Mobility score for retrofitted medical offices was 0.771 (SD = 0.088);  $t(8) = 1.77$ ,  $p = 0.057$ . The mean Overall score of buildings built for the purpose of housing medical offices was 0.848

(SD = 0.053) and the mean of Overall scores for retrofitted medical offices was 0.790 (SD = 0.075);  $t(8) = 1.42$ ,  $p = 0.097$ .

The following page contains Mean Diamond and X-Axis Proportional graphs produced by JMP statistical software. The graphs contain two diamonds and black dots, one diamond represents facilities designed for the purpose of housing medical offices (yes) and the other represents the facilities that were retrofitted to facilitate medical offices (no). Each black dot represents the OHCUP results for the ten facilities evaluated. The width of the diamond represents the proportional sample size, the midline represents the mean of the respective results, the top and bottom of the diamond represent 95% confidence intervals, and the green lines are overlap marks indicating where the two groups overlap at the given confidence interval. The black line across the middle of the x-axis indicated the total group mean (JMp, 2019).

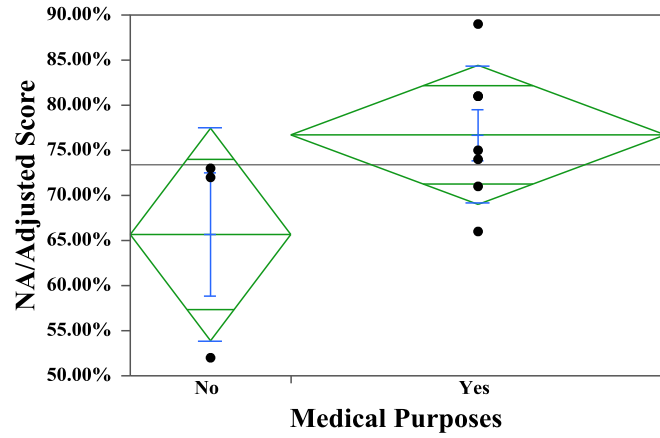

Figure 8: Medical purpose effect on N/A adjusted score

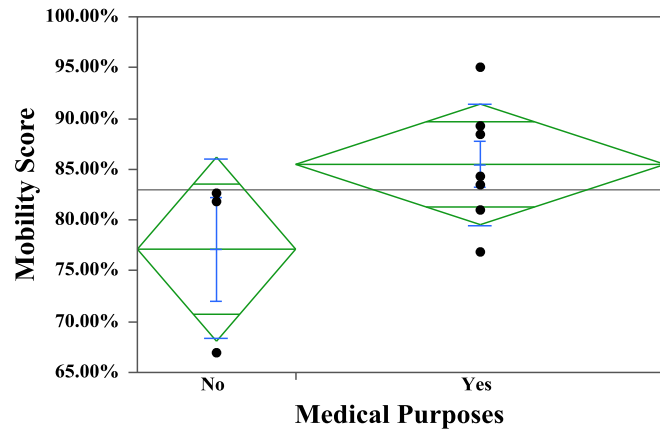

Figure 9: Medical purpose effect on mobility score

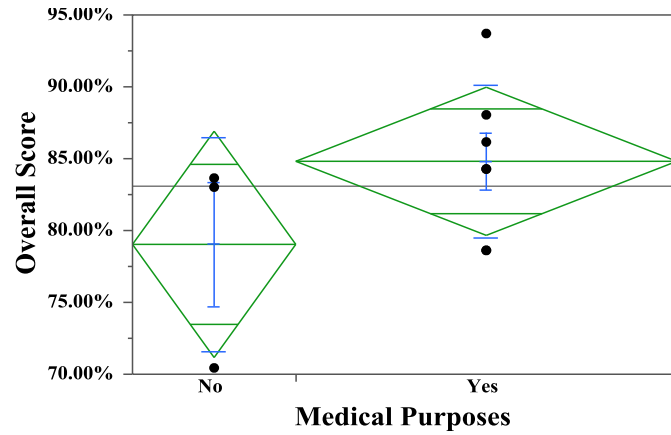

Figure 10: Medical purpose effect on overall score

Although tested, the mean of the two groups for Sensory score indicated no statistical significance or trend.

### *Nonparametric Data*

A separate test for the nonparametric of the Cognitive section was conducted using a Wilcoxon-Mann-Whitney Ranked Sums Test using the median of the results. A box plot is used to display these results. The top and bottom lines represent the minimum and maximum values, the boxes represent 25-75% data ranges, and the diamond indicated the means of the respective results (SAS

User's Guide: The NPAR1WAY Procedure, 2019). This test indicated significant differences between the ranked mean score of the two groups, suggesting that building built with the purposes of housing medical offices score better in the Cognitive Section of the OHCUP ( $Z = -1.708$ ,  $p = 0.044$ ).

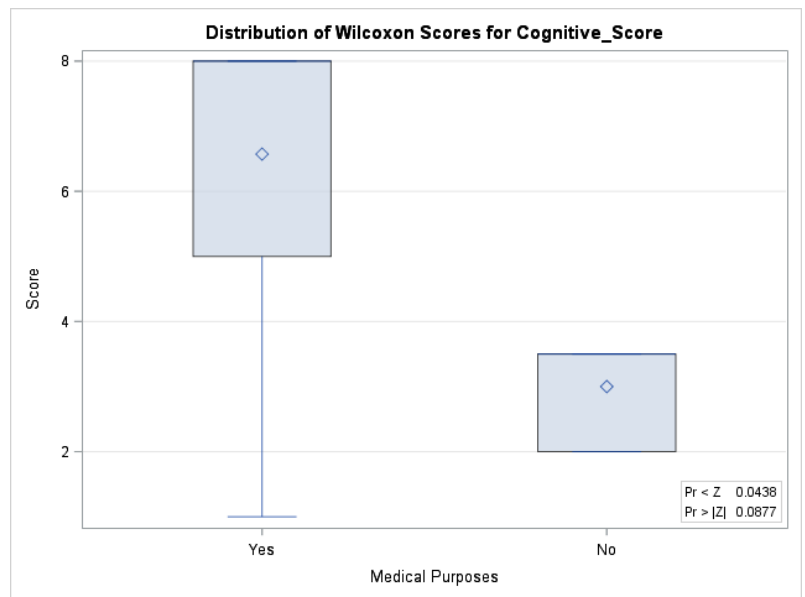

Figure 11: Medical purpose effect on Cognitive score

## CHAPTER V

### Discussion and Conclusion

#### Need for Research

Since the establishment of the ADA, newly constructed buildings must successfully meet the ADAAG requirements. As a result, health care facilities are becoming increasingly accessible for people with disabilities. However, 25 years after the passing of the ADA, progress is slow and many facilities remain non-compliant with certain regulations. Research shows that issues of non-compliance arise primarily within facilities built prior to the passing of the ADA and that knowledge and original building purpose also positively correlate with accessibility scores. In addition, West Virginia has a high rural population of 38% and rural residence report a high level of perceived access barriers. Rural parts of the country face added environmental barriers such as distances that average two to three times that of non-rural residence. This places an added emphasis on quality of care for these remote sites.

Similar research in accessibility in South Carolina found health care sites to be 70% accessible an abbreviated tools measuring relevant ADAAG items. Consistently, issues with accessible exam equipment such as wheelchair accessible scales, transfer devices, and height adjustable tables as well as issues of inaccessible restrooms, entryways and parking lots were prevalent in health care facilities (Graham & Mann, 2008).

This research aimed to investigate accessibility in rural West Virginia and how the correlating factors assessed in similar research affects the usability of health care facilities. This was conducted by identifying a sample of rural health care facilities in the state, surveying them on their information about their age and original purpose, then following up with a visit aimed to

assess their usability. Usability was defined as the minimum threshold of ADAAG items for a facility to be considered usable for patients with disabilities according to OHCUP research. Ten facilities were identified and surveyed in coordination with the WVPBRN.

### **Summary of Findings**

The mean Mobility score of the facilities surveyed was 82.98%, the mean Sensory score was 84.14%, the mean Cognitive score was 86.35%, and the mean overall score was 83.08%. The OHCUP is a more comprehensive tool than tools used in comparative research and was designed with facility administrators in mind as opposed to researchers. As such, it included an N/A option for items that did not apply to specific facilities. In this instance, the facilities received one point, which was equivalent to a 'yes' or accessible mark when calculating scores. This option was not included in the primary comparative study out of South Carolina, which removed items that did not exist within participating facilities. In order to more accurately compare these results an N/A adjusted scores were calculated by removing inapplicable items as per necessary in each facility. For example, if a facility did not have an elevator, the elevator items were not counted toward their final score. When these categorized into disability type (Mobility, Sensory and Cognitive) and adjusted for non-applicable items, the clinics scored an average of 73%, 70%, and 82%, respectively. Once adjusted for inapplicable items the overall score fell to a mean of 73.04%.

Sub-categorical results showed that Counters (55.00%), Lab Specimen Rooms (70.83%), Restrooms (71.00%), and Exam Rooms (73.35%) scored at or below the N/A adjusted mean and signage (74.64%) and parking (77.14%) fell below the overall mean. Particular items that were non-compliance in half or more of facilities surveyed include ADA compliant entrance signs,



availability of lift or transfer devices, accessible counters, appropriately placed restroom signs, appropriately placed lab specimen room signs, wheelchair accessible entrances to lab specimen rooms, appropriately placed mirrors, accessible dispensers in restrooms and lab specimen rooms, availability of van accessible parking spots, appropriate amount of clear wall space on latch side of doors, wheelchair accessible entrances to restrooms, appropriately place hand dispensers in restrooms and lab specimen rooms, wheelchair accessible scales, clear space between toilet to wall, accessible emergency alarms, and appropriately placed rooms signs within the general facility. It is also important to note sub-categories with positive results, such as passageways, approach, and ramps which all featured both commonly evaluated items and aggregate results with over 90% compliance before adjusted for non-applicable items.

Finally, correlational data revealed that there was a significant moderate negative correlation between approximate building age and Mobility score. A statistical trend and moderate negative correlation was identified for Overall and N/A adjusted scores. Sensory and Cognitive scores showed no correlation with approximate building age and were not statistically significant. This is likely because sensory and cognitive items have less to do with the integrity of the building and more to do with additions beyond that included in the design such as signage, alarms, sensors, and charts.

When discovering the role building purpose played in usability, the results were limited by a small sample size although showed a statistical trend that indicated that retrofitted buildings were less usable in Mobility, N/A Adjusted, and Overall scores. Nonparametric Wilcoxon test for Cognitive score showed a significant difference between the two groups indicating that

building built with medical offices in mind are more usable for people with Cognitive disabilities.

### **Limitations**

The results of this research are subject to a number of limitations inherent in both the survey and the facility evaluation as well as the limited sample size and characteristics inherent of the sample itself. In order to create a survey that was easily completed by facility administrators, it did not require a specific year in which the facility was built but rather the decade in which it was built. In statistical analysis, the midpoint was used to evaluate correlative results. This method was conducive to identifying a general trend for a small sample size but was also limited in that taking a more specific approach would enable the researcher to identify results pre and post the passing of the ADA in 1990, which was a common approach in broader research on the topic. In addition, the addition of a specific year may have led to greater statistical significance among correlational figures. Furthermore, the research did not take into consideration the most recent year of renovation. Like a general pre/post examination, this would have enabled the researcher to categorize facilities into two categories of renovation pre and post the passing of the ADA as well as evaluate the differences in general and correlative results depending on specific year of renovation.

Also, as is the nature of any quantitative tool, evaluation has room for subjectivity and the results concluded using the OHCUP tool may vary among researchers. When designing the study, the researcher noted the potential bias that may occur by having administrator conduct evaluations on their own facilities so evaluations were all conducted by the researcher himself. This research took strides in conducting the evaluation in a consistent way but may be

interpreted differently by other administrators of the tool or, in rare cases, even when administered again by the same person. When designing the tool OHCUP researchers established inter-rater reliability of 0.89 for Cohen's Kappa and 0.97 for Gwet's AC1 statistics. The specific method in which this research utilized the tool is laid out in the Method section of this thesis. Ambiguous items most notable include instances of measurement and in cases of parking spaces being shared by other businesses. Points were awarded for items that rounded to the nearest inch (<.5 in) in instances where the measurement was required and an established number of parking spots associated with the practice were established with the administration before evaluation began. In a number of instances, treating the required measurement as an absolute threshold as opposed to a rounded figure would have lowered the scores of the facilities and subsequently altered the results negatively. That said, this research also served as a pragmatic evaluation for each facility and for the WVPBRN and adhering to items in an absolute way may have detracted from the practical nature of the original purpose of the research which included raising awareness among participating facilities of their usability. In the event that a measurement was rounded the full point was awarded and was noted to the administrator.

The research may also be limited by the size of the sample and the nature of the sample. The available population of rural health clinics in West Virginia is only fifty clinics according to the Rural Health Information Hub (2019). While ten facilities are not representative of the fifty total rural health care locations, a purposeful sample was curated by establishing available clinics with a research network (WVPBRN) that offered outpatient care, was rural as per RUCA codes 7.0 – 10.0, and diverse in terms of health care system. According to Krejcie and Morgan's (1970) article on determining sample size for small populations a random sample of 44 would be

necessary to be representative of the 50 total rural health care clinics. This research falls considerably short of that figure, although its findings are consistent with similar research with statistically representative samples. Finally, the fact that the sample consisted of members of a research network (although the network has no specific requirement to become a member) may in itself impact the results. It is possible that the results are skewed by the fact that all participating clinics are consistently willing subjects of research activity, although more prominently clinical, and not environmental, research is most commonly conducted by the WVPBRN.

## **Discussion**

After evaluation of the ten outpatient health care facilities in rural West Virginia this research resulted in findings consistent with that of research cited in a review of literature. Research on the accessibility of health care facilities in South Carolina concluded that in a sample of 68 sites using a 93-item tool, clinics were 70% accessible. This research found that once adjusted for items that did not apply to individual facilities, rural outpatient health care sites scored 73% on ADAAG items considered a minimum threshold for a facility to be considered ‘usable.’

Notable, the accessibility score fell 10 points when adjusted for non-applicable items. This is also true for Mobility score. Sensory score fell 14 points and Cognitive score fell only four points. In conducting this research both scores are important. In sharing the results with WVPBRN members, the clinics should be aware of their score solely as it pertains to the ADAAG items they feature, as the OHCUP intends. However, in comparing results both between participating clinics and between relevant research, clinics should be evaluated at a

more comparative standard. A clinic should not be subject to a lower score because their total items scored are higher than another clinic. The purpose of further research should dictate future research design as it pertains to scoring the OHCUP. N/A Adjusted scores may be sufficient in academic research but in using the OHCUP as an informational tool for clinics, either solely or supplementary (as in this research), future researcher may opt into using one or both methods. Note that N/A Adjusted means are not a function of the OHCUP tool itself, but a method of comparative analysis designed for the purposes of this research. Obviously, other tools exist to serve similar purposes, and as this research suggests, may serve to produce comparative results.

The review of literature highlighted specific areas and ADAAG items that were consistently found to be noncompliant. Parking lots, restrooms (including lab specimen rooms), and exam rooms were most commonly cited as incompliant areas in broader research with items like car and van accessible parking, clear floor space and grab bars in restrooms, wheelchair accessible scales, height-adjustable exam tables, and lift devices most notable mentioned as inaccessible or unavailable design features. These results are all consistent with the findings of this research. The OHCUP evaluation, which assesses more ADAAG items than any other research cited in the review of literature, found that additional areas of concern include counters, signage. Countertops were too high in 9/10 of facilities. None of the facilities featured an accessible entrance sign, only one facility had fully accessible and appropriately placed restroom signs. In addition, elevators were only applicable to two facilities but were only 69% compliant in items assessed.

In predicting usability of health care facilities this research found that age exhibited a moderately negative correlation for usability scores. This is true most notable in for Mobility

scores, followed by N/A Adjusted scores, then in Overall scores as well. This is consistent with findings in larger studies. Although limited by sample size the research suggests that the original purpose of the building may be a factor used to predict accessibility. Year of construction pre and post the passing of the ADA, year of most recent renovation, and administrative knowledge of the ADA are all cited as factors contributing to accessibility scores of health care facilities, but were not tested in this research.

### **Further Research**

In the event of further research on this topic correlating factors cited above should be examined in addition to a re-examination of the general findings of this study. Specific opportunities for new research on the topic may include the design of a new valid, reliable and abbreviated tool to easily enable facilities to evaluate themselves. The findings of this research and research cited in the review of literature may aid in that effort. In addition, a tool of this nature may aid in additional research analyzing outpatient health care on a larger scale. This research will conclude with a short tool highlighting important, and commonly non-compliant items observed during research in order to be broadly disseminated among member sites of the WVPBRN. It will contain approximately 25 items, access to comprehensive tools, and resources available to achieve further compliance. Additional research is necessary to fine-tune the idea of that tool on an academic scale.

This research serves to further the knowledge of accessibility of health care in rural West Virginia and underscore the reality of access to health care for people with disabilities in general. In addition, ten rural sites in the state are better informed to make changes needed to improve their own access. Accessibility is an ever-changing and ever-improving landscape. Continued

research is needed to make patients and providers aware of the situation and motivate positive outcomes as we progress toward a society with equal opportunity for all of its citizens.

### References

ADA - Findings, Purpose, and History. (n.d.). Retrieved from

[https://www.adaanniversary.org/findings\\_purpose](https://www.adaanniversary.org/findings_purpose) America's Health Rankings.

(2019). *Explore Binge Drinking in West Virginia | 2018 Annual Report*. [online]

Available at:

<https://www.americashealthrankings.org/explore/annual/measure/Binge/state/WV>

[Accessed 23 Jan. 2019].

Americans With Disabilities Act of 1990, Pub. L. No. 101-336, 104 Stat. 328 (1990).

Armour, B. S., Swanson, M., Waldman, H. B., & Perlman, S. P. (2008). A profile of state-level differences in the oral health of people with and without disabilities, in the US, in 2004. *Public Health Reports*, 123(1), 67.

Bump, P. (2017, March 03). How the economy of West Virginia has changed over the past 25 years. Retrieved from

<https://www.washingtonpost.com/news/politics/wp/2017/03/03/how-the-economy-of-west-virginia-has-changed-over-the-past-25-years/>

Burton, J. (2019). *The US States With the Oldest Populations*. [online] WorldAtlas. Available at: <https://www.worldatlas.com/articles/the-us-states-with-the-oldest-population.html> [Accessed 23Jan. 2019].

Buzza, C., Ono, S. S., Turvey, C., Wittrock, S., Noble, M., Reddy, G., Reisinger, H. S. (2011). Distance is Relative: Unpacking a Principal Barrier in Rural Health care. *Journal of General Internal Medicine*, 26(S2), 648-654. doi:10.1007/s11606-011-1762-1

Center Research (2019). « *Highest to Lowest Share of Blue Collar Jobs By State Blue Collar Jobs Tracker*. [online] Bluecollarjobs.us. Available at: <https://bluecollarjobs.us/2017/04/10/highest-to-lowest-share-of-blue-collar-jobs-by-state/> [Accessed 23 Jan. 2019].

Chan, L., Doctor, J. N., MacLehose, R. F., Lawson, H., Rosenblatt, R. A., Baldwin, L. M., & Jha, A. (1999). Do medicare patients with disabilities receive preventive services? A population-based study. *Archives of Physical Medicine and Rehabilitation*, 80(6), 642-646. [http://dx.doi.org/10.1016/S0003-9993\(99\)90166-1](http://dx.doi.org/10.1016/S0003-9993(99)90166-1)

Chan, L., Hart, L. G., & Goodman, D. C. (2006). Geographic Access to Health Care for Rural Medicare Beneficiaries. *The Journal of Rural Health*, 22(2), 140-146. doi:10.1111/j.1748-0361.2006.00022.x

Christiadi (2019). *WVUToday Archive*. [online] Wvutoday-archive.wvu.edu. Available at: <http://wvutoday-archive.wvu.edu/n/2012/05/18/wvu-state-s-shrinking-working-age->



- population-could-affect-future-economic-growth.html [Accessed 23 Jan. 2019].
- Cromartie, J., & Bucholtz, S. (2008). *Defining the "Rural" in Rural America*(3rd ed., Vol. 6, p. 32) (United States of America, USDA, ERS). Amber Waves.
- Drum, C. E., Horner-Johnson, W., & Walsh, E. S. (2012). Construction and validation of the Outpatient Health Care Usability Profile (OHCUP). *Disability and Health Journal*, 5(4), 292-297. doi:10.1016/j.dhjo.2012.08.001
- Earle, S., & Church, S. (2004). Disability and reproduction. *Practicing Midwife*, 7(8), 32-34.
- Farmer, G.C., Grant, D., Papachristou, T., & Ramirez, A. (2001) Disability and preventive cancer screening: results from the 2001 California Health Interview Survey *Journal of Public Health*, 95 (11) (2005), pp. 2057-2064
- France, D. J., Throop, P., Walczyk, B., Allen, L., Parekh, A. D., Parsons, A., . . . Deshpande, J. K. (2005). Does Patient-Centered Design Guarantee Patient Safety? *Journal of Patient Safety*,1(3), 145-153. doi:10.1097/01.jps.0000191550.92042.36
- Goins, R. T., Williams, K. A., Carter, M. W., Spencer, S. M., & Solovieva, T. (2005). Perceived Barriers to Health Care Access Among Rural Older Adults: A Qualitative Study. *The Journal of Rural Health*, 21(3), 206-213. doi:10.1111/j.1748-0361.2005.tb00084.x
- Grabois, E. W. (1999). Accessibility of Primary Care Physicians Offices for People With Disabilities: An Analysis of Compliance With the Americans With Disabilities Act. *Archives of Family Medicine*, 8(1), 44-51. doi:10.1001/archfami.8.1.44

Graham, C.L., Mann, J.R. (2008) Accessibility of primary care physician practice sites in South Carolina for people with disabilities. *Disability Health Journal* 1:209–214.

JMp (2019) Mean Diamonds and X-Axis Proportional. Retrieved from <https://www.jmp.com/support/help/14-2/mean-diamonds-and-x-axis-proportional.shtml>

Leigh, J. P., & Fries, J. F. (1992). Disability in occupations in a national sample. *American Journal of Public Health*, 82(11), 1517-1524. doi:10.2105/ajph.82.11.1517

Pharr, Jennifer R., Bungum, Tim (2012). Health Disparities Experienced by People with Disabilities in the United States: A Behavioral Risk Factor Surveillance System Study. *Global Journal of Health Science*; 4 (6) 99-108

Havercamp, S. M., Scandlin, D., & Roth, M. (2004). Health disparities among adults with developmental disabilities, adults with other disabilities, and adults not reporting disability in north carolina. *Public Health Journal Reports*, 119(4), 418. <http://dx.doi.org/10.1016/j.phr.2004.05.006>

Hernandez, B., Keys, C., & Balcazar, F. (2003). The Americans With Disabilities Act Knowledge Survey: Strong psychometrics and weak knowledge. *Rehabilitation Psychology*, 48(2), 93-99. doi:10.1037/0090-5550.48.2.93

Iezzoni, L. I. (2002). Satisfaction with quality and access to health care among people with Disabling conditions. *International Journal for Quality in Health Care*, 14(5), 369-381. doi:10.1093/intqhc/14.5.369

Iezzoni, L. I., McCarthy, E., Davis, R., & Siebens, H. (2000). Mobility impairments and use of

- screening and preventive services. *American Journal of Public Health*, 90(6), 95  
<http://dx.doi.org/10.2105/AJPH.90.6.955>
- Iezzoni LI, Davis RB, Soukup J, O'Day B. Satisfaction with quality and access to health care among people with disabling conditions. *International Journal for Quality in Health Care* 2002;14(5):369.
- Kirschner, K. L., Breslin, M. L., & Iezzoni, L. I. (2007). Structural Impairments That Limit Access to Health Care for Patients With Disabilities. *Jama*, 297(10), 1121.  
doi:10.1001/jama.297.10.1121
- Krejcie, R.V., & Morgan, D.W. (1970). Determining Sample Size for Research Activities. *Educational and Psychological Measurement*, 30, 607-610
- Mayerson, A. (1992). The history of the ADA: A movement perspective. Retrieved September 9, 2004, from <http://www.dredf.org/articles/adahist.htm>
- Mattingly, M., & Edwards, K. M. (2012). Perceptions of Intimate Partner Violence: Results from Focus Groups with Rural Adults. *PsycEXTRA Dataset*. doi:10.1037/e621642012-255
- Morrison EH, George V, Mosqueda L. Primary care for adults with physical disabilities: perceptions from consumer and provider focus groups. *Fam Med* 2008;40(9):645.
- Mudrick, N. R., & Schwartz, M. A. (2010). Health care under the ADA: A vision or a mirage? *Disability and Health Journal*, 3(4), 233-239. doi:10.1016/j.dhjo.2010.07.002
- Mudrick, N. R., Breslin, M. L., Liang, M., & Yee, S. (2012). Physical accessibility in primary health care settings: Results from California on-site reviews. *Disability and Health Journal*, 5(3), 159-167. doi:10.1016/j.dhjo.2012.02.002

- Mullin, K. (2009). Considering Retail Health Clinics. *JONA: The Journal of Nursing Administration*, 39(12), 531-536. doi:10.1097/nna.0b013e3181c1809b
- Pharr, Jennifer R., Bungum, Tim (2012). Health Disparities Experienced by People with Disabilities in the United States: A Behavioral Risk Factor Surveillance System Study. *Global Journal of Health Science*; 4 (6) 99-108
- Pharr, J. (2013). Accessible medical equipment for patients with disabilities in primary care clinics: Why is it lacking? *Disability and Health Journal*, 6(2), 124-132. doi:10.1016/j.dhjo.2012.11.002
- Pharr, J., & Chino, M. (2013). Predicting barriers to primary care for patients with disabilities: A mixed methods study of practice administrators. *Disability and Health Journal*, 6(2), 116-123. doi:10.1016/j.dhjo.2012.11.003
- Rimmer, J. H., & Braddock, D. (2002). Health Promotion for People with Physical, Cognitive, and Sensory Disabilities: An Emerging National Priority. *American Journal of Health Promotion*, 16(4), 220-224. doi:10.4278/0890-1171-16.4.220
- Rural Health Information Hub. (2017). Retrieved December 02, 2017, from <https://www.ruralhealthinfo.org/states/west-virginia>
- Sanchez, J., Byfield, G., Brown, T. T., Laffavor, K., Murphy, D., & Laud, P. (2000). Perceived Accessibility Versus Actual Physical Accessibility of Health care Facilities. *Rehabilitation Nursing*, 25(1), 6-9. doi:10.1002/j.2048-7940.2000.tb01849.x
- SAS 9.2 User's Guide: The NPARIWAY Procedure [PDF]. (2019). SAS.
- Skillman, S. M., Palazzo, L., Keepnews, D., & Hart, L. G. (2006). Characteristics of Registered

Nurses in Rural Versus Urban Areas: Implications for Strategies to Alleviate Nursing Shortages in the United States. *The Journal of Rural Health*,22(2), 151-157.

doi:10.1111/j.1748-

0361.2006.00024.x

Stark, S.L., Hollingsworth, H., Morgan, K., Chang, M., Gray, D.B., The interrater reliability of the Community Health Environment Checklist Arch Phys Med Rehabil, 89 (2008), pp. 2218- 2219

Story, M. F., Schwier, E., & Kailes, J. I. (2009). Perspectives of patients with disabilities on the accessibility of medical equipment: Examination tables, imaging equipment, medical chairs, and weight scales. *Disability and Health Journal*,2(4).

doi:10.1016/j.dhjo.2009.05.003

THE AMERICANS WITH DISABILITIES ACT OF 1990 - ADA. (n.d.). Retrieved from

<https://www.olmsteadrights.org/about-olmstead/item.6460->

[The\\_Americans\\_with\\_Disabilities\\_Act\\_of\\_1990\\_ADA](#)

The History of Americans with Disabilities Act. (2017). Retrieved December 01, 2017, from

<https://dredf.org/news/publications/the-history-of-the-ada/>

The State of Obesity. (2019). *State Briefs*. [online] Available at:

<https://stateofobesity.org/states/wv/> [Accessed 23 Jan. 2019].

U.S. Bureau of the Census (2010). Poverty. Retrieved December 02, 2017, from

<https://census.gov/topics/income-poverty/poverty.html>

U.S. Bureau of Labor Statistics. (2019). Retrieved from <https://www.bls.gov/>

USDA, Economic Research Service. (2016, October 12). *Rural Area Commuting Codes*.

Retrieved from <https://www.ers.usda.gov/data-products/rural-urban-commuting-area-codes.aspx>

Vollset, S. E. (1993). Confidence intervals for a binomial proportion. *Statistics in Medicine*, 12(9), 809-824. doi:10.1002/sim.4780120902

West Virginia Department of Education (2019). *Urban/Rural Designation for West Virginia Counties and the E-rate Discount Matrix - E-rate*. [online] Available at: <https://sites.google.com/a/wvde.k12.wv.us/erate/training-information/training-updates/fcc-and-sld-numbers-needed-for-application/urban-rural-designation-for-west-virginia-counties-and-the-e-rate-discount-matrix> [Accessed 23 Jan. 2019].

Whiteneck, G. G., Harrison-Felix, C. L., Mellick, D. C., Brooks, C. A., Charlifue, S. B., & Gerhart, K. A. (2001). Craig Hospital Inventory of Environmental Factors. *PsycTESTS Dataset*. doi:10.1037/t28927-000

Appendix A: IRB Acknowledgment



**Acknowledgement of Exemption**

---

08/23/2018

**To:** John Haddox

**From:** WVU Office of Research Integrity & Compliance

**Protocol Type:** Exempt

**Approval Date:** 08/23/2018

**Submission Type:** Initial

**Expiration Date:** 08/22/2021

**Funding:** N/A

**WVU Protocol #:** 1802995833

**Protocol Title:** Usability of Rural Health Care Facilities in West Virginia For People with Disabilities

---

The West Virginia University Institutional Review Board has reviewed your submission of Exempt protocol 1802995833. Additional details regarding the review are below:

- This research study was granted an exemption because the Research involves educational tests, survey procedures, interview procedures or observation of public behavior and (i) information obtained is recorded in such a manner that human subjects cannot be identified, directly or through identifiers linked to the subjects; and (ii) any disclosure of the human subjects responses outside the research could not reasonably place the subjects at risk of criminal or civil liability or be damaging to the subjects financial standing, employability, or reputation [45 CFR 46.101(2)]. All exemptions are only good for three years. If this research extends more than three years beyond the approved date, then the researcher will have to request another exemption. The following documents have been acknowledged for use in this study and are available in the WVU+kc system:

The following documents were reviewed and approved for use as part of this submission. Only the documents listed below may be used in the research. Please access and print the files in the Notes & Attachments section of your approved protocol.

- consent letter.docx

Protocol #: 1802995833

Phone: 304-293-7073

FWA: 00005078

Fax: 304-293-3098

IORG: 0000194

Email: IRB@mail.wvu.edu

- ADA Knowledge and Clinic Demographical Survey.docx
- ohcup\_v4\_fed\_current.pdf
- WVPBRN Letter of Support - J Miller 4-27-18.pdf

**WVU IRB acknowledgement of protocol 1802995833 will expire on 08/22/2021.**

If the study is to continue beyond the expiration date, a renewal application must be submitted no later than two (2) weeks prior to expiration date. It is your responsibility to submit your protocol for renewal.

Once you begin your human subjects research, the following regulations apply:

1. Unanticipated or serious adverse events and/or side effects encountered in this research study must be reported to the IRB within five (5) days, using the Notify IRB action in the electronic protocol.
2. Any modifications to the study protocol should be submitted only if there will be an increase in risk to subjects accompanying the proposed change(s).
3. You may not use a modified information sheet until it has been reviewed and acknowledged by the WVU IRB prior to implementation.

The Office of Research Integrity and Compliance will be glad to provide assistance to you throughout the research process. Please feel free to contact us by phone, at 304.293.7073 or by email at [IRB@mail.wvu.edu](mailto:IRB@mail.wvu.edu).

Sincerely,



Protocol #: 1802995833  
FWA: 00005078  
IORG: 0000194

Phone: 304-293-7073  
Fax: 304-293-3098  
Email: [IRB@mail.wvu.edu](mailto:IRB@mail.wvu.edu)

Appendix B: WVPBRN Letter of Suppo



April 9, 2018

Dear Mr. Miller,

On behalf of the West Virginia Practice-Based Research Network (WVPBRN), we are delighted to inform you that your project, "Barriers to ADA Accessibility Guideline Compliance in Primary Care Clinics", has been approved as an official WVPBRN project.

Our network currently has 86 individual primary care clinics among 21 health systems around West Virginia and has a rich history of prior experience and collaborations with clinic staff and providers. The network includes 338 providers serving over 395,000 patients across West Virginia. All network-level projects are required to complete a review process by the network to assess the relevance and feasibility in terms of practice-based research designed to meet the needs and interests of WV primary care. This proposal fits the mission of the network by improving access to healthcare resources in the communities and has been favorably reviewed by the WVPBRN Co-Directors and the Protocol Review Committee.

This memorandum will serve as approval to begin the project. We anticipate you will begin the project promptly; the approval is good for one year. If you do not start within 12 months, you will need to re-submit the proposal to the WVPBRN for review, to assess feasibility and resource availability at that time.

To fulfill your obligations to the WVPBRN, you will need to do the following:

- 1--IRB approval before the research begins,
- 2--Submit progress reports at the six-month interval and at the project completion or annually,
- 3--Submit a detailed dissemination plan for reporting research results to the appropriate professionals/clinicians and to the practices and communities utilized in the research.

As a network project, the WVPBRN offers a variety of support services, including research design and data analysis, recruitment strategies, organizational resources, and translation and dissemination of research results strategies and tools and practices designed to improve patient outcomes. Please be assured that you will have the full support and cooperation of the WVPBRN in this endeavor. We look forward to collaborating with you on this project and in the future.

Congratulations.

A handwritten signature in black ink, appearing to read 'William Lewis', is positioned above the typed name and title.

William Lewis, MD  
Harpers Ferry Family Medicine  
Co-Director, WVPBRN

A handwritten signature in black ink, appearing to read 'Jennifer Boyd', is positioned above the typed name and title.

Jennifer Boyd, PA-C  
New River Health Association  
CO-Director, WVPBRN

Appendix C: ADA Knowledge and Clinic Demographical Survey

**ADA Knowledge and Clinic Demographical Survey**

**Administrative Information**

Name of current practice?

Administrator age?

Years as administrator?

Years at current practice?

Education?

**Building Characteristics**

Years practice in operation?

Type of practice?

Building built?

**Answer the following True or False Questions**

1. The presence of a physical disability in itself is sufficient evidence of a disability to provide protection under the ADA.\*
2. Let's say that the cost of installing a ramp from the sidewalk to an existing store imposes an undue burden on a business owner. Then under the ADA that is sufficient reason for not making this modification.
3. According to the ADA, when a facility is renovated, alterations must comply with the ADA accessibility guidelines to the maximum extent feasible.
4. The ADA encourages alternative methods to resolve disputes prior to legal action.
5. The ADA requires that all newly constructed businesses be accessible.
6. The term "readily achievable" is defined by the ADA as easily accomplished and able to be carried out without much difficulty or expense.
7. The ADA does not allow private individuals to bring lawsuits and obtain court orders to stop discrimination in public places.\*
8. Consider this situation: It has been found that reproducing a menu in Braille imposes an undue

financial burden on an owner of a small restaurant. True or False: According to the ADA, having the waiter read the menu to customers with visual disabilities may be a reasonable modification of a policy, practice, or procedure.

9. According to the ADA, persons with disabilities have the right to file disability discrimination complaints with the Department of Justice, Equal Employment Opportunity Commission, and/or the Department of Transportation.
10. The ADA supports that tax benefits be given to businesses to help defray the cost of removing physical barriers such as entrances without ramps and narrow doorways.

1. Hernandez, B., Keys, C., & Balcazar, F. (2003). The Americans With Disabilities Act Knowledge Survey: Strong psychometrics and weak knowledge. *Rehabilitation Psychology, 48*(2), 93-99. doi:10.1037/0090-5550.48.2.93

# Outpatient Health Care Usability Profile V4

---

Drum, C.E., Davis, C.E., Berardinelli, M., Cline, A., Laing, R., Horner-Johnson, W., & Krahn, G.

This tool reflects **FEDERAL** guidelines. It is necessary to verify whether your state or local codes have more stringent accessibility requirements; if so, they take precedence.

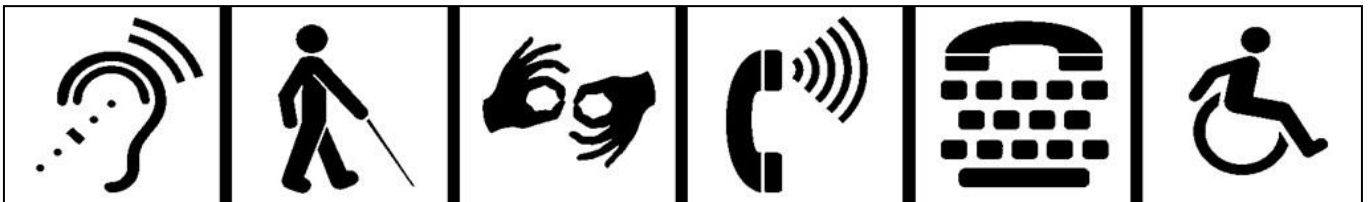

Funded by the National Institute on Disability and Rehabilitation Research Office of Special Education and Rehabilitative Services, U.S. Department of Education. Grant NumberH133B040034.

Graphic images used with permission from the Kentucky Department of Vocational Rehabilitation.

RRTC: Health & Wellness  
Oregon Institute on Disability & Development  
707 SW Gaines Street  
Portland, OR 97239  
(voice) 503-494-3534  
Relay 7-1-1 [rrtc@ohsu.edu](mailto:rrtc@ohsu.edu)  
healthwellness.org



Outpatient Health Care Usability Profile V4-Fed

Date \_\_\_\_\_

Pre-Survey  
Post-Survey

Clinic Name \_\_\_\_\_

Address \_\_\_\_\_  
\_\_\_\_\_

Contact Info \_\_\_\_\_

NAME

\_\_\_\_\_  
PHONE

\_\_\_\_\_  
EMAIL ADDRESS

Start Time \_\_\_\_\_ End Time \_\_\_\_\_

Notes:

Parking Lot  
Parking Garage  
Bathroom \_\_\_\_\_ (Specifically  
indicate which bathroom used on Pre-Survey pp. 34-  
43.)

Lifts (Check if clinic has lifts to survey)  
Elevators (Check if clinic has an elevator to survey)  
Stairs (Check if clinic has stairs to survey)



## Contents

Tips on Completing the OHCUP	4
Frequently Asked Questions	6
Section 1: Patient Arrival	7
Parking	7
Approach to Building	9
Ramps	11
Signage	13
Controls	17
Doors	18
Section 2: Public Facilities	20
Telephones	20
Seating	22

Counters	23
Passageways	24
Water Fountains	26
Lifts	28
Elevators	29
Stairs	33
Rest Rooms	35
Emergency Egress (a route or path for going out in case of an emergency)	44
Section 3: Exam Rooms and access to Primary Services	46
Appendix A: Parking Requirements	56
Appendix B: Overall Scoring Sheet	57
How to calculate your overall score	61
Appendix C: Mobility Scoring Sheet	62
How to calculate your mobility score	66
Appendix D: Sensory Scoring Sheet	67
How to calculate your sensory score	69
Appendix E: Cognitive Scoring Sheet	70
How to calculate your cognitive score	72

## Tips on Completing the OHCUP

**Read** the OHCUP thoroughly to become familiar with the questions and flow. It will take a minimum of two hours to complete the survey for each clinic. Allow yourself time to greet the staff and answer any questions they may have.

The OHCUP is divided into three sections:

1. **Patient Arrival:** *Starts at the parking lot and examines the path of travel to the clinic. This includes entrance ramps and doors, controls, directional signage to the clinic and directional signage within the clinic.*
2. **Public Facilities:** *Includes telephones, water fountains, waiting room seating and reception counters, passageways, emergency egress and, perhaps most important, restrooms. Lifts, elevators and stairs are surveyed only if needed to enter or exit the clinic.*
3. **Exam Rooms and Access to Primary Services:** *Includes the clinic's accessible exam room and restroom most frequently used (restroom adjoining the lab specimen collection restroom, if applicable).*

Within each **Section** you will also find **Subsections** that provide additional information to help you complete specific areas within the clinic. Some questions include graphics to provide a visual cue for taking measurements.

At the end of each section, a space for notes is provided. Many OHCUP questions are generalized and may apply to several locations within a clinic. Use the space provided to describe elements of poor accessibility (e.g., the location of and force required to open public doors, including restroom doors) or to take note of contextual factors that may be brought to light by staff (e.g., clinic is undergoing renovations).

Within each section, each item should be judged independently from the other. You will answer **YES, NO, or N/A** (not applicable) for each item.

Some sections may be irrelevant in some clinics. For example, if there are no lifts in a clinic, each question in that section would be answered “N/A”.

Please read each question completely before answering and verify that you are at the correct location. Remember to answer the questions with only a

**YES, NO or N/A.** This is important when it comes time to score.

See Frequently Asked Questions on page 5, #3 for more information on scoring.

### **About Scoring**

You will be able to enter only a 1 or 0. “Yes” and “N/A” answers are scored as 1, which means “usable.” A “NO” answer is scored as 0, which means “not usable.” There are scoring sheets at the end of the OHCUP with further instructions. You can also use an electronic scoring sheet by contacting **Danielle Bailey** at 503-494-4858.

**Special Note: Whenever a sign using the International Symbol of Accessibility (ISA) is required, that symbol may not be a stylized or “designer” version of the symbol; only the prescribed ISA may be used:**



**This Checklist is NOT a substitute for federal accessibility guidelines and/or the appropriate state and local building codes.**

For more information see

the *Americans with Disabilities Act Accessibility Guidelines* (ADAAG) at the

US Access board website: [www.access-board.gov/gs.htm](http://www.access-board.gov/gs.htm) .

## Frequently Asked Questions (FAQ)

### Q 1. What equipment will I need to complete the survey?

You will need a pencil, measuring tape (25' or longer), and a SmartTool or other level that can determine slope measurement. Although the OHCUP does not ask about door-opening pressure, we recommend that you use a door pressure gauge (or a fish scale) to test doors for number of pounds of pressure needed to open them (the degree of opening difficulty). It should take no more than 5 pounds of pressure to open an **interior** door. (Your state may or may not have **exterior** door-opening requirements. Contact your state and local building codes for details. In Oregon, for example, it should take no more than 8 ½ pounds of pressure to open an **exterior** door. *Even if your state has no specific requirements regarding exterior doors, it is wise to test exterior doors and adjust each one to the least feasible door opening pressure.* )

### Q 2. What about the required number of accessible parking spaces needed? Must I count all the spaces in the lot?

Yes. Appendix A shows a chart for determining the required number of accessible spaces needed based on the total number of spots in the whole parking lot. The text at the bottom of that chart box explains that for outpatient clinics, the number of accessible spaces required is 10% of the total number of spaces provided. (If 10% of the total number

comes out as a fraction, it is necessary to use the next largest whole number as the required number. That means if you have 83 parking spaces in a lot, 10% would be 8.3 spaces, so the actual number of required accessible spaces would be 9.)

**Q 3. How do I answer a question if part of it can be answered “yes” and part can be answered “no”?**

Answer the question “no” if ALL parts of the question cannot be answered “yes.” One question about restrooms, for example, says, “**All** dispensers and hand dryers are operable with a closed fist.” Because the hand dryer and the soap dispenser are operable with a single, closed fist, we might be tempted to answer affirmatively; however, we notice that the toilet seat cover dispenser is not operable with a single closed fist. We must answer “no” to the entire question. Keep in mind that some paper towel dispensers, even those with an automatic sensor, may still not be operable with a single, closed fist. Typically, the only accessible hand dryer is the hot-air blower type with push button or automatic sensor. If you are in doubt, simply try using only one hand, held in a loose clenched-fist position, to get a paper towel from a dispenser.

**Q 4. What if there is more than one restroom in the clinic? Which one should**

**I survey?**

The OHCUP has a section to use to evaluate a single restroom. **Only one restroom’s survey** results can be used in the final scoring. You will want to report the scores of the restroom that clinic patients use the most and record the location on the cover sheet if you plan to do a 9-month follow-up (post) survey.

---

Section 1: Patient Arrival

---

Parking - applies only to parking area within the immediate vicinity of the clinic

---

1. The required number of designated parking spaces are provided (i.e. 10% of total parking spaces) and each designated space has a sign that displays the International Symbol of Accessibility shown to the right (see Appendix A).

- Yes
- No



one in every

eight designated

- Yes 2. At least

- No parking spaces is van accessible.

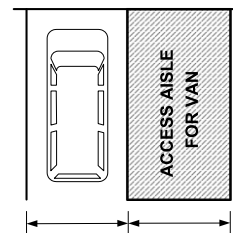

96 96  
INCHES INCHES



---

3. There are 98 inches of vertical clearance available for lift-

- Yes
- No

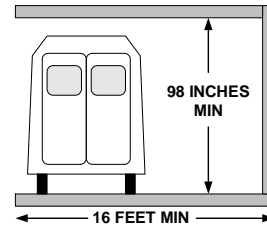

- equipped vans.
- N/A Mark "N/A" only if vehicles are parked in an open area (with any overhanging foliage above 98") and not in a parking garage.

- 
4. All designated parking spaces are on the shortest route of travel to the building's accessible entrance.  Yes  No

You may have to ask what the clinic considers their "accessible" entrance.

- 
5. Access aisles are present between designated spaces and surfaces are firm, stable and slip resistant.  Yes  No

- 
6. In designated passenger loading zones, there is an access aisle at least 5 feet wide and 20 feet long adjacent and parallel to a vehicle pull-up space.

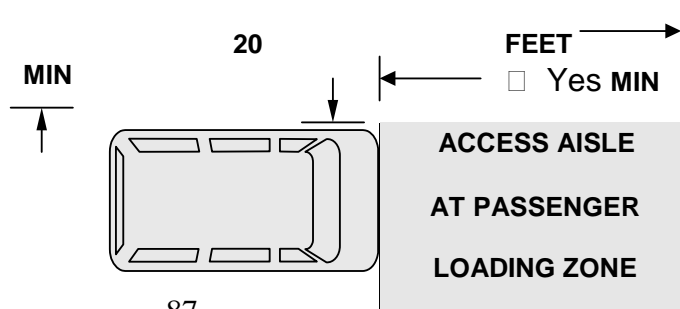

No                      **5 FEET**

N/A

May be marked "Patient Drop-Off" or  
alternatively identified with signs  
or painted stripes. **If no  
identifiable zone, then mark  
"N/A."**

---

7. Curb ramps in the

parking area have a

Yes

smooth transition from

ramp to the

ramps are

unnecessary.

No the

pedestrian route of Mark "N/A" only if curb

N/A travel

---

**NOTES : PARKING**



---

Approach to Building - applies from parking area to entrance of building

---

Yes

8. The route of travel  
does not require  
the use of stairs.

No

---

9. The surface of the route of travel is stable, firm and slip-resistant.

Yes

No

---

10. The route leading to the building is at least 36 unobstructed inches wide.

Yes

No

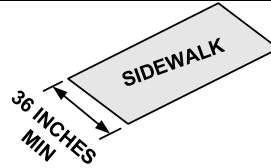

---

11. All curbs on the route of travel have curb ramps.

Yes

No

N/A

If no curbs, then write "N/A." Ramp should have a slope no greater than 1:12 (measured at steepest point), stable, firm, and slip resistant, 36 inches wide exclusive of flared sides. If ramp does not meet these criteria, mark "No."

---

12. Where there are stairs at the main entrance, there is either a ramp, lift, or an alternative entrance provided.

Yes

No

N/A

Mark "N/A" if there are no stairs at main entrance.

---

13. When alternative

entrances are

used, there is a

Yes

sign at the main

No

entrance

indicating the

N/A

location of the

alternative

entrance.



Mark "N/A" only if there are no alternative entrances used.

---

14. Alternative

Yes

entrances can be

used without

No

assistance.

N/A

Mark "N/A" only if there are no alternative entrances used.

---

15. The entrance door

has at least 32 inches clear opening (for a double door, at least one leaf with a 32- inch clear opening).

Yes

No

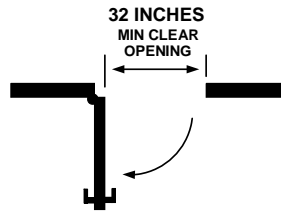

---

16. There are at least 18 inches of clear, unobstructed wall space next to the latch side of the door (to get in **and** out).

Yes

No

N/A

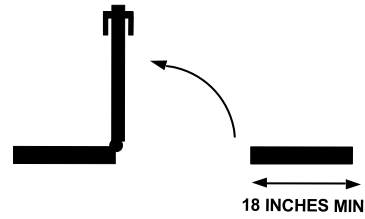

If the door is automatic, mark "N/A."

---





---

Ramps (where they exist along the path of travel)

---

Mark each question "N/A" if no ramps are present.

---

18. The slope of a ramp  Yes  
(rise over run) should  
be no greater than 1:12  No  
(or 8.33%)  N/A

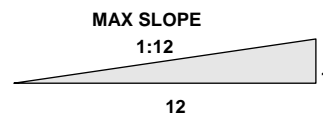

- Yes
19. The surface of the  
ramp is stable, firm and  
slip resistant.  No  
 N/A
- 

- Yes
20. The unobstructed width  
of the ramp is 36  
 No inches.

N/A

21. Any ramp that rises more than 6 inches or is longer than 72 inches has handrails on both sides.

- Yes
- No
- N/A

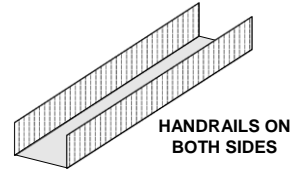

22. The tops of the 34 and 38 inches above the ramp surface.

- Yes handrails are between
- No
- N/A

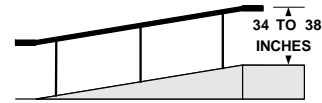

23. When the ramp changes direction, there is a level landing of at least 60 by 60 inches.

- Yes
- No
- N/A

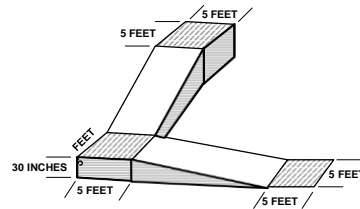

<b>NOTES : RAMPS</b>

Signage (those that direct to and within a clinic only)

---

**Section A (Questions 24-26): Signs mounted above 80 inches.**

Measure signs along path of travel from building entrance to clinic entrance, and within clinic itself.

---

24. If mounted above 80 inches, characters on signs that provide directions and information have letters at least 3 inches high.

Yes  
 No  
 N/A

Mark "N/A" if no signs are mounted above 80 inches.

---

25. If mounted above 80 inches, characters on signs that provide directions and information have high contrast.

Yes  
 No

Mark "N/A" if no signs are mounted above 80 inches.

---

---

---

N/A

---

26. If mounted above 80 inches,  
characters on signs that provide  
directions and information have a  
non-glare finish.

Yes  
 No  
 N/A

Mark "N/A" if no  
signs are mounted  
above 80 inches.

---

**NOTES : SIGNS MOUNTED ABOVE 80 INCHES**

---

**only.**

**): Measure**

---

27. Signs designating all  Yes  
permanent rooms and  
spaces are present  No
- 

28. Signs are mounted with  Yes  
centerlines 60 inches from  No  
floor.  N/A

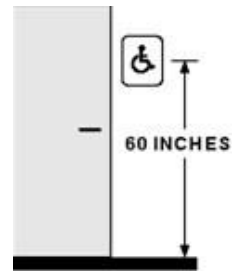

Measurement of 60 inches should be taken from the middle of the sign.

Mark "NA" if answer to Q27 is "No."

- 
29. Signs are mounted on the  Yes  
wall adjacent to the latch  No  
side of the door and

outside the door swing.

N  
/  
A

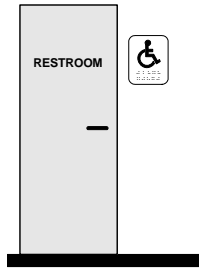

Mark "NA" if answer to Q27 is "No."

---

Yes

30. Signs have characters and  
if answer to Q27  
"No."

No background with a non-  
glare finish. is Mark "NA"  
 N/A

---

---

Yes

31. Signs have raised  
characters.

No Mark "NA" if answer to Q27  
is "No."  
 N/A

---

Yes

32. Signs feature high contrast lettering and backgrounds.  No

Mark "NA" if answer to Q27 is "No."

N/A

---

Yes

33. Signs feature Braille text.  No

Mark "NA" if answer to Q27 is "No."

N/A

---

34. When a pictogram is used to designate rooms and spaces, it is accompanied by raised characters and Braille.  Yes

No

Mark "N/A" if no pictograms are used.

N/A

---





**Section C (Question 35): Measure sign at clinic entrance only.**

---

36. Sign is present at

entrance to clinic at a  Yes

height of 60 inches to

centerline and features

high contrast, raised  No

and Braille characters,

and non-glare finish.

---

**NOTES : SIGN AT CLINIC ENTRANCE**

---

Controls (e.g. light switches, door handles)

---

37. All controls available to

the public have controls  Yes

with the highest

operable part no  No

greater than 48" and

lowest operable part no

lower than 15".

Controls include light switches,

locks, vending machines,

television controls, fire alarms, etc.

---

38. All controls that are  Yes

available to the public

are operable with a  No

single, closed fist.

---

**NOTES : CONTROLS**



Doors (within the clinic building, excluding the entrance doors)

39. When a door is opened to 90 degrees, there is a clear opening width of at least 32 inches measured between the face of the door and the door stop on the latch

Yes

No

N/A

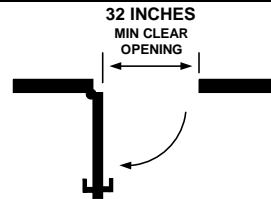

Mark "N/A" only if no doors are used

side.

within clinic.

---

40. Clear space between doors in a series is at least 48 inches.

- Yes
- No
- N/A

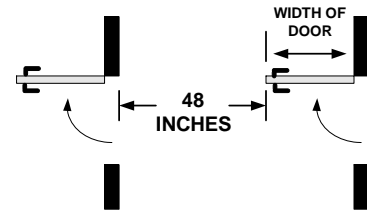

If both doors are automatic, then mark "N/A."

41. There is at least 18 inches of clear wall space on the latch side of doors (to get in **and** out).

- No
- N/A

Judge doors from waiting room to exam room/ lab restroom on the path of travel only.

---

inches of clear wall

- Yes

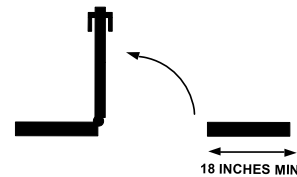

Mark "N/A" if door can be operated automatically.

---

42. The operating hardware is mounted no higher than 48 inches above the floor.

- Yes
- No
- N/A

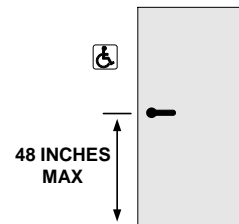

If door opens automatically with a

sensor, enter "N/A."

---

43. All handles, locks, and other opening  Yes

---

latches or

hardware are operable with a single closed fist.  No

N/A

Mark "N/A" only if no doors are used within clinic. If operated by a control device, consider whether it is usable with closed fist.

---

44. All threshold edges are 1/4 inch high or less, or if beveled edge, no more than 1/2 inch high.  Yes  
 No  
 N/A

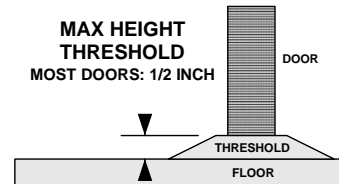

---

45. No more than five pounds of force is required to open an interior door (e.g., doors used by automatic door opening pressure, see FAQ #1, page  Yes  
 No restroom door). For Mark "N/A" if all information about public are  N/A exterior

---

---

**NOTES : DOORS**

Section 2: Public Facilities

---

Telephones (any available for public use along path of travel)

---

Mark "N/A" if **no** telephone is available for public use. Any phone for public use should be assessed, even if it is not a pay phone.

---

---

46. The designated telephone has at least 30 by 48 inches of clear floor space.

- Yes
- No
- N/A

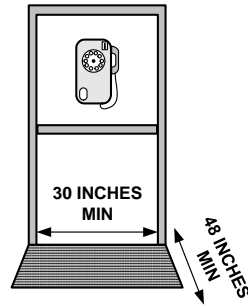

---

47. The route to the telephone is at least 36 unobstructed inches wide adjoining or overlapping the clear floor space.

- Yes
- No
- N/A

48. The highest operable part of the phone is no  Yes higher than 48 inches. Be sure to check coin  No and/or credit card slot height.  N/A

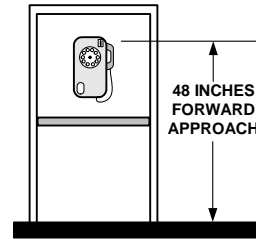



49. If a wall-mounted telephone has a  Yes leading edge between 27 and 80 inches from  No the floor, it projects less than 4 inches into  N/A the pathway.

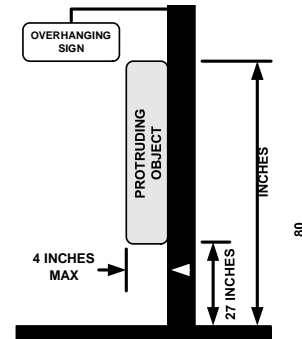

Enter "Yes" if telephone is recessed and not projecting into passageway.

50. The designated phone is adapted with volume control.

- Yes  
 No  
 N/A

Alternatively, look for volume

adjustment button near keypad.

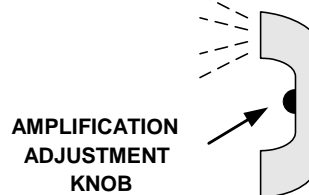

51. Volume controlled telephones are identified by a sign showing a handset radiating sound waves.

- Yes  
 No  
 N/A

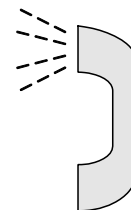

---

52. When telephone banks (2 or more adjacent public phones) do not  Yes contain a text telephone (TTY), there  No is a sign to indicate location of nearest  N/A TTY.

---

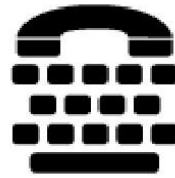

<b>NOTES : TELEPHONE</b>

---

**Seating (in waiting area only)**

---

Yes

53. All aisles between  No

seating are at least 36

unobstructed inches  N/A

wide.

Mark "N/A" only if there is no seating area provided.

---

Yes

54. There is a space for a  No

person in a wheelchair

to wait without blocking

the clear width of any  N/A

aisles.

Mark "N/A" only if no seating area is provided.

---

**NOTES : SEATING**



Counters (along the path of travel)

55. The tops of tables or counters are between 28 and 34 inches high.

- Yes
- No
- N/A

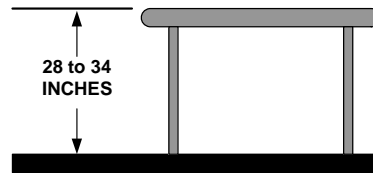

56. When tables\* are provided (excluding end tables) at least one high, 30 inches wide and 19 inches deep.

has knee space of at least 27 inches

- Yes
- No

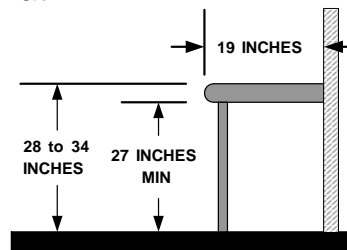

\*This question is concerned

transaction areas) for both clinic personnel and patients - for example, a check-out station, registration area, or reception desk.

- N/A with tables or counters that provide seats (or



---

N/A      If temporary objects protrude into passageway, then measure passageway to edge of object.

---

58. If the passageway is **less than 60 inches wide**, there are

Yes

passing spaces at least

60 inches wide and 60

inches long or

intersecting walks

allowing passing at

reasonable intervals not

exceeding 200 feet.

---

No

If passageway is more than 60

inches wide, mark N/A.

N/A

59. There is a 5-foot circle **or** a T-shaped space (36 inches wide each direction and 60 inches minimum depth) to

reverse direction.

Yes

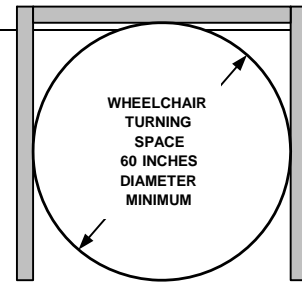

No

N/A

Note: This is a difficult measurement to make. It may require 2 people working together to make an accurate reading. Study the diagram closely, and take your time making your measurement.

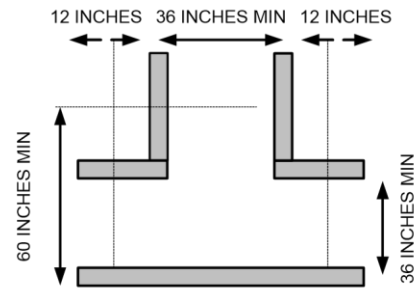

60. Where a passageway makes a U-turn around an obstacle which is less than 48 inches

wide, the passageway

Yes

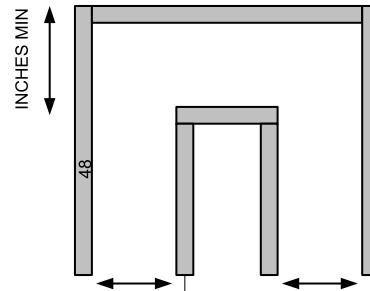

MIN

No width increases to at least 42 inches on the

N/A 42 INCHES MIN approaches and 48 42 INCHES

inches in the turn.

Mark "N/A" if there is no U-turn around obstacle.

change in level is  No

between 1/4 and 1/2

inch, there is a beveled  N/A

edge with a slope no

greater than 1:2.

Mark "N/A" if there is no change in

floor level. (This often occurs

where building additions have

been made.)

61. If passageway levels change, the vertical difference is less than 1/4 inch, or if the

Yes

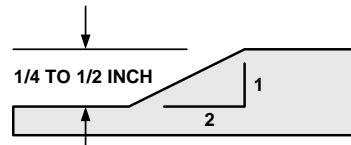

62. Wall-mounted objects that have leading edges between 27 inches and 80 inches from the floor project

Yes

No

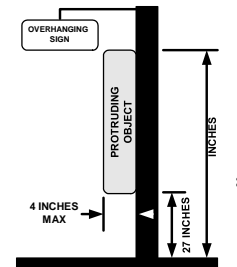

than 4 inches into  N/A

the passageway.

less

Mark "N/A" if no protruding objects

are found. Objects with edges that extend below 27" are not considered obstructions because they are cane-detectable.

Carpeting is low-pile,

Yes 63.





Water Fountains (where they exist along the path of travel)

Mark "N/A" if no fountain is available to the public.

64. Where fountains are provided, there is a clear floor space of at least 30 by 48 inches.

- Yes
- No
- N/A

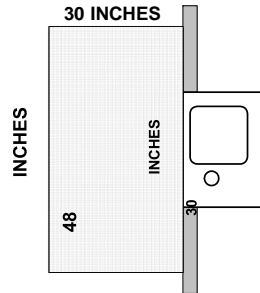

65. When fountains are provided, there is at least one fountain with its spout fixture no higher than 36 inches from the floor.

- Yes
- No
- N/A

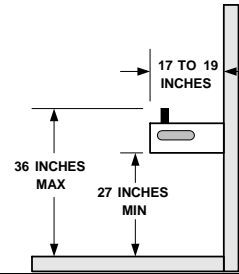

66. If a wall-mounted fountain has a leading edge between 27 and 80 inches from the floor, it projects less than 4 inches into the pathway.

protruding object if it is not recessed or does not have an extension underneath to bring it down to 27" to be cane detectable.]

- Yes
- No
- N/A

[Note: There may be a high-low fountain arrangement.

The high fountain may be a

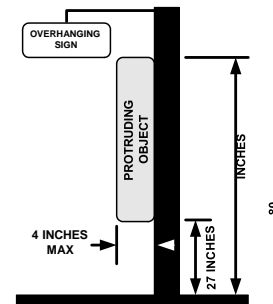



---

Lifts (when provided along the path of travel)

---

Mark "N/A" only if lift is not required to access clinic services and public facilities.

---

67. Where a lift is

provided, it is usable  Yes

without assistance (i.e.,

key is in lock and

doesn't have to be  No

retrieved from

somewhere; door is

operable with a closed  N/A

lift).

---

68. If the lift is not usable  Yes

without assistance, a

call button is provided  No

and staffed whenever

the clinic is open.  N/A

---

69. The lift controls are

operable with a closed  Yes

lift).

---

---

---

No

N/A

---

70. The lift controls are  
located no higher than  
48 inches for a forward  
approach.

Yes

No

N/A

---

71. The lift controls are  
located no higher than  
54 inches for a side  
approach.

Yes

No

N/A

---

The floor surface of the  
lift  
is slip-resistant and  
change in level is  
less than 1/4 inch.

Yes 72.

No any  
less

---



---

Elevators (where they exist along the path of travel)

---

Mark "N/A" if elevators are not required to access clinic services and public facilities.

---

73. The call button has a visual signal that indicates direction of travel.

- Yes
- No
- N/A

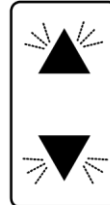

74. The call button has an "DING"

audible signal that indicates direction of

No

"DING - DING" travel.

N/A

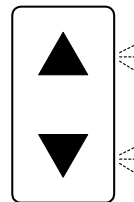

75. There are signs identifying the floor number in raised letters on both sides of the door jamb of the elevator at every floor.

- Yes
  - No
  - N/A
-

- 
76. There are signs  Yes  
 identifying the floor in  
 Braille letters on both  No  
 door jambs of the  
 elevator at every floor.  N/A
- 

77. The elevator  Yes  
 automatically comes  
 No within 1/2 inch of the  
 floor landing at each  N/A stop.

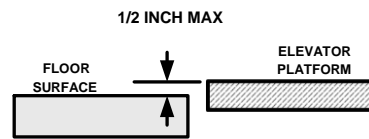

SIDE VIEW

78. The elevator is large  
 enough  Yes  
 that a  
 wheelchair user can  
 enter, reach the  No controls and exit.

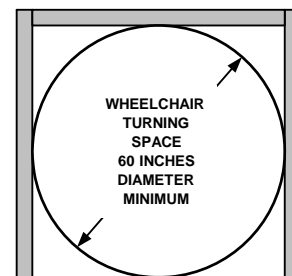



---

† N/A

---

79. The elevator doors reopen automatically without contact if an object passes through the opening between 5 and 29 inches above the floor.

- Yes
- No
- N/A

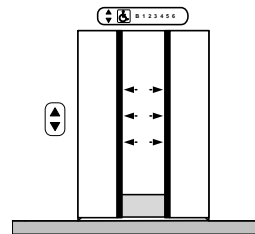

---

80. When reopened, the door stays open for at least 20 seconds.

- Yes
- No
- N/A

---

---

Yes

81. The control buttons  
inside the elevator  
have Braille lettering.

No

N/A

---

82. The control buttons  
inside the elevator No  
lettering. have raised  
N/A

---

83. If provided, the  
emergency  
communication system  Yes

(e.g., handset,  
intercom) is identified  No

in both Braille and  
raised letters.  N/A

84. If provided, the emergency communication system (e.g., handset, intercom) is no higher than 48 inches above the floor.

- Yes
- No
- N/A

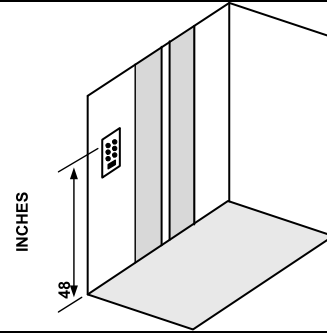

85. All elevator controls are no lower than 15 inches and no higher than 48 inches from floor.

- Yes
- No
- N/A

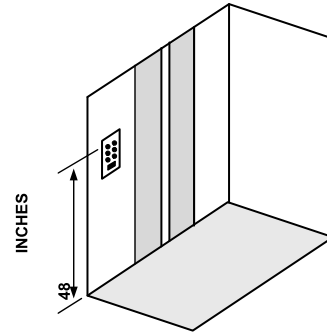

**NOTES : ELEVATORS**

---

Stairs (where they exist along the path of travel)

---

Mark "N/A" only if stairs are not a part of the path to clinic services and public facilities.

---

86. Handrails have 12-inch extensions beyond the top riser.

- Yes
- No
- N/A

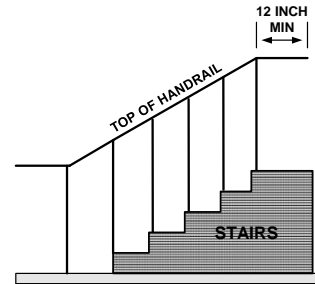

---

---

87. Handrails have 12-inch extensions beyond the bottom riser.

- Yes
- No
- N/A

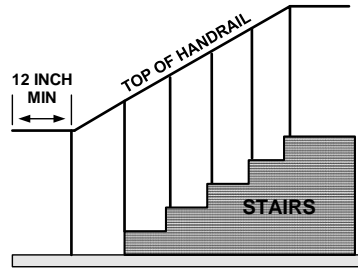

---

88. For stairs along the path of travel, the risers are closed.

- Yes
- No
- N/A



---

89. For stairs along the path of travel, the steps have uniform riser height and tread width.

- Yes
- No
- N/A

90. If there are stairs between the elevator and primary clinic services, there is a designated route without stairs.

- No
- designated
- N/A

---

---

**NOTES : ELEVATORS**

---

***Rest Rooms (Instructions: Assess restroom in public waiting room only).***

---

***Features for both toilet stalls and toilet rooms.***

---

91. Signs are mounted on the wall on the latch side of the door, 60 inches from the floor to the middle of the sign.  Yes  No

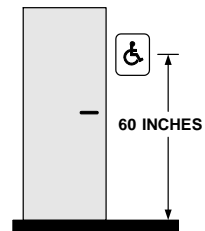

Measurement of 60 inches should be taken from the middle of the sign.

- 
92. Where pictograms or symbols are used to identify rest rooms,  Yes
-

---

---

Braille characters are included below them.

- No  
 N/A

Mark "N/A" if no pictograms are used.

---

93. Where pictograms or symbols are used to identify rest rooms, raised characters are included below them.

- Yes  
 No  
 N/A

Mark "N/A" if no pictograms are used.

---

94. The restroom doorway is at least 32 inches wide.

- Yes  
 No

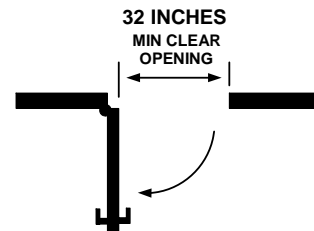

95. Doors are operable with a single, closed fist.

- Yes  
 No
-



---

If operated by a control, consider whether it is usable with a single, closed fist.

96. Door handles are no higher than 48 inches.

Yes placed  No

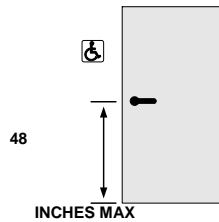
 N/A

unobstructed path to all  Yes

fixtures (e.g., sink,

dispensers).  No

99. The sink has a 30-inch wide by 48-inch deep clear space in front (a maximum of 19 inches of the required depth may be under the sink).

Yes  
 No  
 N/A

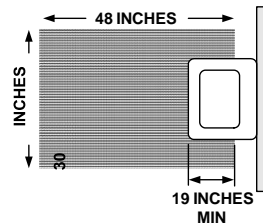

soap and other

---

Mark "N/A" only if door is automatic and operable control is no higher than 48

---

97. The entry is large enough for a wheelchair user to enter, turn around and exit.

Yes

No

Note: This is a difficult measurement to make. It may require 2 people working together to make an accurate reading. Study the diagram closely, and take your time.

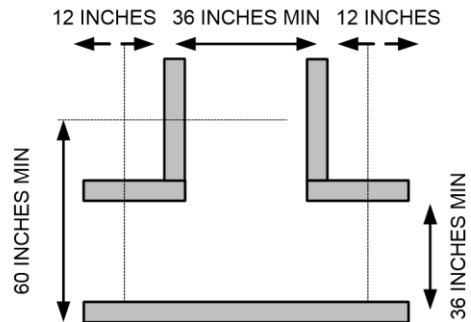
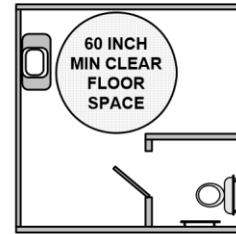

---

98. There is a 36-inch wide inches.

100. Pipes under the sink are insulated to protect against contact.

Yes

No

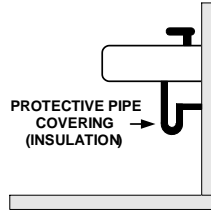

N/A

Mark "N/A" only if there is no sink.

101. Where counters or tables are provided,

Yes

No the top is between 28 and 34 inches from the

N/A floor.

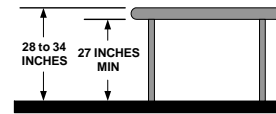

102. The sink rim is no higher than 34 inches.

Yes

No

N/A

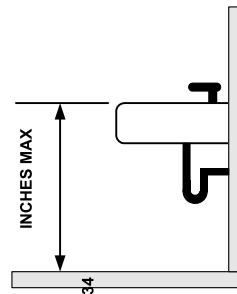

Mark "N/A" only if there is no sink.

103. The faucet is operable with a single closed fist.

Yes

No

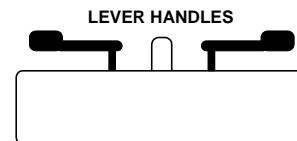

---

N/A

Mark "N/A" only if there is no sink.

---

104. The highest operable part of all dispensers and hand dryers is no higher than 48 inches for a forward approach.

- Yes  
 No  
 N/A

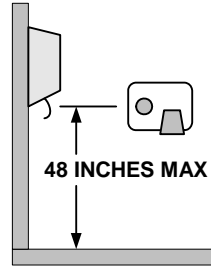

Mark "N/A" only if there are no dispensers.

---

---

105. All dispensers and hand dryers are operable with a single closed fist (pull-down paper-towel dispensers & many seat-cover dispensers are usually not accessible by this criteria).

- Yes  
 No  
 N/A

Mark "N/A" only if there are no dispensers.

- 
- 
106. The mirror is mounted with the bottom edge of the reflecting surface no
- Yes
- No

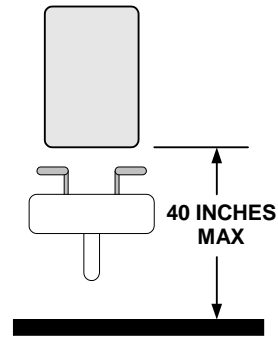

higher than 40 inches.  N/A

Note: This is a difficult measure to take and sometimes requires more than one measurement. Please use caution.

Mark "N/A" only if there is no mirror.

- 
107. There are two horizontal grab bars: one on the wall behind the toilet and one on the side wall nearest to the toilet in the
- Yes
- No

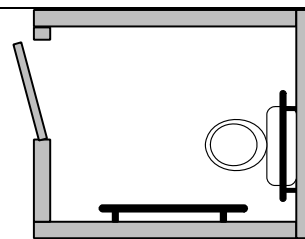

designated stall/toilet room.

Mark "No" if grab bars are not present or are not positioned parallel to floor.

108. The toilet seat is 17"-19" high. Measure from floor to top of seat.
- Yes
- No

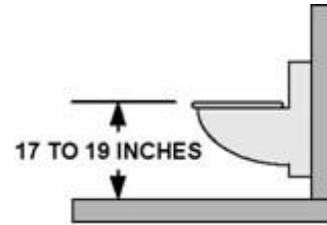

109. There is at least 18 inches of clear space from the center of the toilet to the wall(s) on either side.
- Yes
- No

Note: Make measurement to adjacent wall. Do not include objects such as

toilet paper dispensers in your measurement.

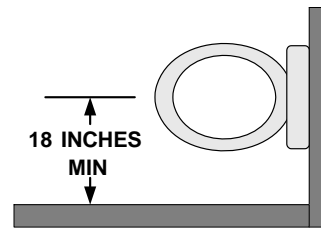

110. At all rest rooms, there is a sign indicating the location of the designated rest room(s).
- Yes
- No
- N/A



This question is specific for other restroom locations. Mark "Yes" if non-accessible restrooms provide directional signage to accessible restroom. Mark "N/A" only if: 1) other public restrooms do not exist/are not

---

---

available to public; or 2) other  
public restrooms are accessible.

---

<b>NOTES : RESTROOMS (GENERAL CHARACTERISTICS)</b>





**(Proceed to next section!!)**

FOR TOILET STALLS ONLY

---

Mark "N/A" if there are no toilet stalls. Proceed to next section: Toilet Room.

---

111. All stall door  Yes hardware  
is operable with a single, closed  
 No  
fist both inside and outside.

112. When stall door is open 90 degrees, there is at least 32-inches' clear width.
- Yes
  - No

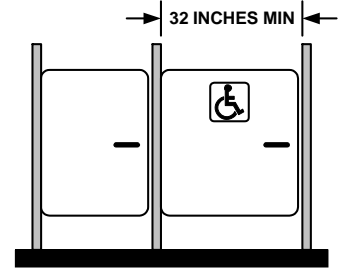

113. There is a designated stall with a clear floor space of at least 5 feet long by 5 feet wide.
- Yes
  - No
  - N/A

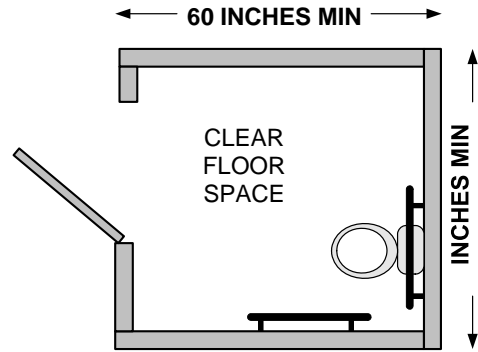

60

114. Where there is no stall with a clear floor space of five feet long and five feet wide, there is a stall that either 36 by 69 inches or 48 inches by 69 inches.

- Yes
- No
- N/A

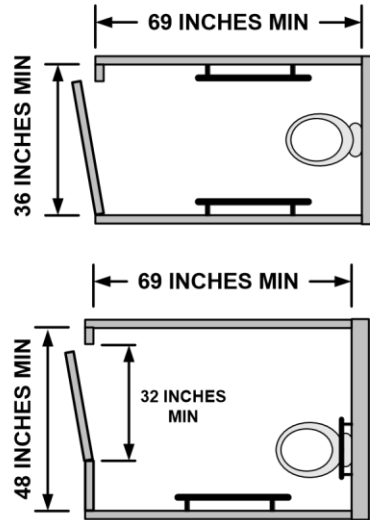

115. There is at least 18 inches of clear space at the latch side of the stall door (to get in and out).

- Yes
- No

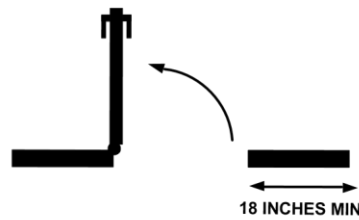

**NOTES : TOILET STALLS ONLY**

---



---



---



---



---



---



---



---

**(Proceed to next section!!)**

FOR TOILET ROOMS ONLY

Mark "N/A" if toilet rooms do not exist (i.e., there are stalls only) **or** if room floor plan is not applicable.

116. Where the toilet is approached from the front and there is a sink alongside the toilet, there is clear floor space of at least 48 inches wide by 66 inches long (toilet wall to opposite wall).

- Yes
- No
- N/A

If door swings inward, measure space clear of door swing. This is easiest done with 2 people.

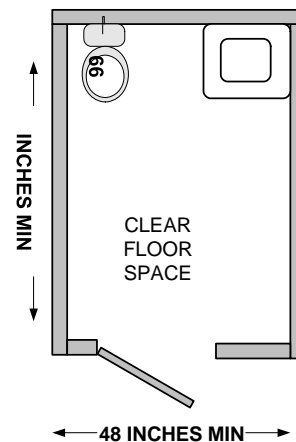

117. Where the toilet is approached from the side and there is a sink alongside the toilet, there is clear floor space of at least 48 inches wide by 56 inches long (toilet wall to opposite wall).

- Yes
- No
- N/A

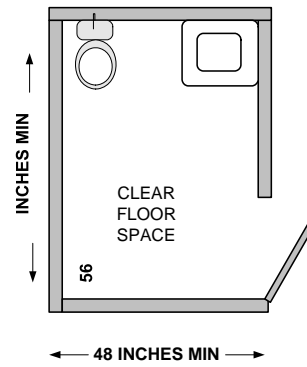

118. Where there is no sink alongside the toilet, there is a clear floor space of at least 60 inches wide by 56 inches long (toilet wall to opposite wall).

- Yes
- No
- N/A

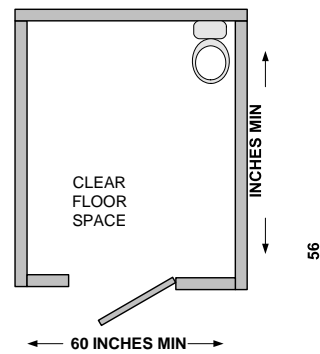

**NOTES : TOILET ROOMS ONLY**

---

---

***Emergency Egress (a route or path for going out in case of an emergency)***

---

119. The emergency route is at least 36 unobstructed inches wide.
- Yes
- No
- If temporary objects protrude into passageway, then measure passageway to edge of object.

- 
120. The emergency route does not require the use of stairs.
- Yes
- No

---

121. Exit doors along the emergency route  Yes  No are accessible doors.

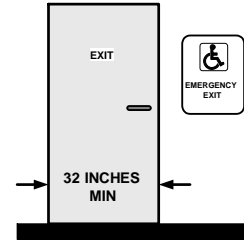



---

122. Where  Yes

emergency alarms are  
provided, they have  
flashing lights.  No

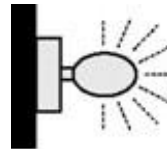

---

123. Where  Yes

emergency alarms are  
provided, they have  
audible signals.  No

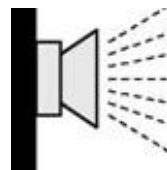

---

124. Where  Yes

emergency alarms are  
provided, additional  
visual alarms are  
installed in general use  
areas such as meeting  
rooms, hallways, lobbies  
and restrooms.  No

---

NOTE: Visual/audible alarms  
should be installed as required  
by the National Fire Protection

---

---

Association (NFPA) code 72

unless there are other state codes that take precedence.

---

125. Each area of rescue assistance (where wheelchair users wait for evacuation) provides at least 2 clear spaces no smaller than 30 by 48 inches.
- Yes
- No
- N/A

NOTE: Areas of rescue assistance are not required in 1-story buildings without elevators. Mark "N/A" for ground-level facilities.

- 
126. Each stairway serving an area of rescue assistance is at least 48 inches wide between handrails.
- Yes
- No
- N/A
- 

**NOTES : EMERGENCY EGRESS**

---

---

---

Section 3: Exam Rooms and access to Primary Services

---

127. There is a loaner wheelchair available.	Yes	You may have to ask staff if a loaner wheelchair is not readily apparent.
	No	

---

---

128. There is a 36-inch clear Yes  
passageway  
(excluding doorways) from  
the waiting area to  
designated exam room. No

---

Yes

129. There is a method to  
weigh a wheelchair-user. No

---

130. The clinic has at  
least one Yes  
heightadjustable exam  
table (lowers to 17-19  
inches). No

---

131. There is at least  
one lift or transfer Yes  
device available for use  
in exam room. No

Mark "N/A" only if this feature is not  
needed. Consider whether a  
transfer device (e.g., step stool with  
arm support) is needed to get on  
exam table.

---

N/A

---

132. The designated exam room is large enough for a wheelchair user to enter, turn around, and exit. Yes  
exit.

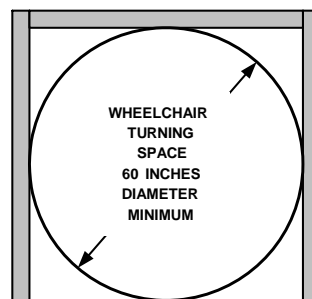

No

Note: This is a difficult measurement to make. It may require 2 people working together to make an accurate reading. Study the diagram closely, and take your time making your measurement.

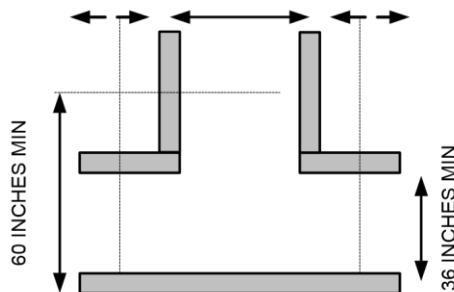

12 INCHES 36 INCHES MIN 12 INCHES

---

133. All controls (e.g., light switches, door handles) are operable with a closed fist.

Yes

No

Controls include light switches, locks, vending machines, television controls, fire alarms, etc.

Mark "N/A" if patient does not need N/A to access controls in exam room.

---

134. When the door is opened to 90 degrees, there is a clear opening width of at least 32 inches measured between the face of the door and the door stop on the latch side.

Yes

No

135. There are graphic charts for assessing pain for patients with cognitive disabilities.

Yes

No

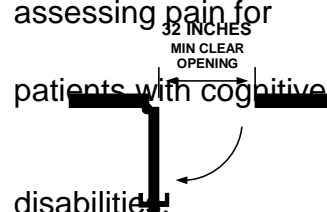

The diagram shows a door partially open. A horizontal line indicates the '32 INCHES MIN CLEAR OPENING' between the door's face and the door stop. A vertical line indicates the door's height. A curved arrow points to the bottom of the door, labeled 'disabilities'.

---

You may have to ask clinic personnel if a chart is available for



(Proceed to next section!!)

---

**TOILET ROOMS WHERE LAB SPECIMENS ARE COLLECTED should meet the following standards.**

**If there is no toilet room with a specimen pass-through, mark each question in this part “N/A.”**

---

136. There is a toilet room where lab specimens are collected.	Yes     N/A	Mark “NA” if there is not a toilet room reserved specifically for collecting lab specimens. If “NA” is marked, mark “NA” for the remaining questions in this section.
--	----------------------------	---

---

137. Signs are mounted 60 inches to the centerline on the wall on the latch side of the door, <u>out of the way of the door swing.</u>	Yes  No  N/A
--	--------------------------





---

138. Where

Yes

pictograms or symbols

are used to identify rest

No

Mark "N/A" if no pictograms are used.

rooms, Braille

characters are included

N/A

below them.

---

139. Where

Yes

pictograms or symbols

Mark "N/A" if no pictograms are used.

are used to identify rest

No

rooms, raised

characters are included

---

---

N/A

below them.

---

140. The restroom doorway is at least 32 inches wide.

Yes

No

N/A

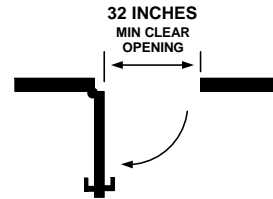

	Yes	
141. Door handles are operable with a single, closed fist.	No	If door control is used, consider whether it is usable with a single, closed fist. N/A

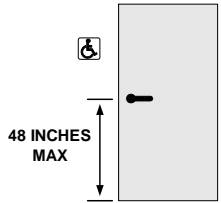
142. Door handles are placed no higher than 48 inches.	Yes	 <p>48 INCHES MAX</p>
	No	
	N/A	

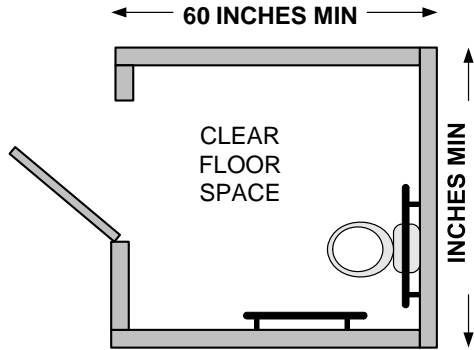
143. The entry is large enough for a wheelchair user to enter, turn around, and exit.	Yes	 <p>60 INCHES MIN</p> <p>CLEAR FLOOR SPACE</p> <p>INCHES MIN</p>
Note: This is a difficult measurement to make. It may require 2 people working together to make	No	
	N/A	

60

---

an accurate reading. Study the diagram closely, and take your time making your measurement.

---

144. There is a 36-  
inch wide unobstructed  
path to all fixtures (e.g.  
sink, towel dispenser).  
Yes  
No  
N/A

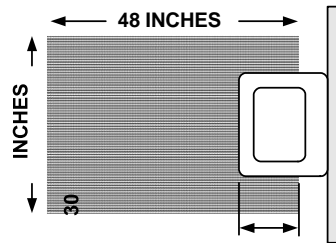

---

145. The sink has a 30 inch wide by  
48 inch Yes deep clear space in  
front. A maximum of No 19  
inches of the  
required depth may be N/A 19 INCHES MIN under the sink.  
Mark "N/A" if there is no sink.

---

---

146. Pipes under the sink are insulated to protect against contact.

Yes  
No  
N/A

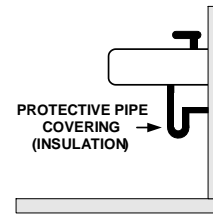

Mark "N/A" if there is no sink.

---

147. Where counters or tables are provided, the top is between 28 inches and 34 inches from the floor.

Yes  
No  
N/A

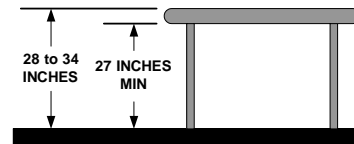

---

148. The sink rim is no higher than 34 inches.

Yes  
No  
N/A

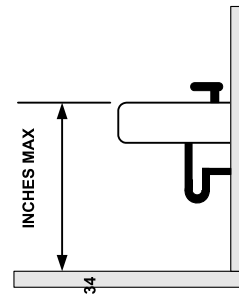

Mark "N/A" if there is no sink.

---

149. The faucet is operable with a single, closed fist.

Yes  
No  
N/A

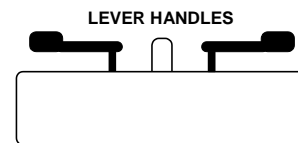

Mark "N/A" if there is no sink.

---

150. The highest operable part of all dispensers and hand dryers is no higher than 48 inches. N/A

No

than 48

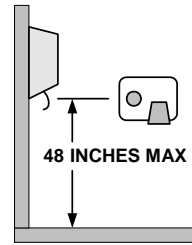

Mark "N/A" if there are no dispensers.

151. All dispensers and hand dryers are operable with a single fist.

Yes closed

No

Mark "N/A" if there are no dispensers.

(Pull-down paper-towel dispensers & many seat-cover dispensers are usually not accessible by this criteria.) N/A

152. The mirror is mounted with the bottom edge of the reflecting surface no higher than 40 inches.

Yes

No

N/A

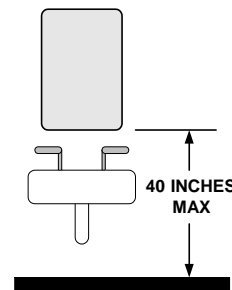

Note: This is a difficult measure to

take and sometimes requires more than one measurement. Please use caution.

Mark "N/A" if there is no mirror.

153. There are horizontal grab bars on Yes the wall behind the toilet and on side wall No nearest to the toilet in the designated N/A stall/toilet room.

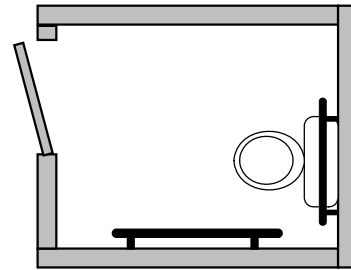

Mark "No" if grab bars are not present or are not positioned parallel to floor.

154. The toilet seat is 17 inches to 19 inches high. Yes No N/A

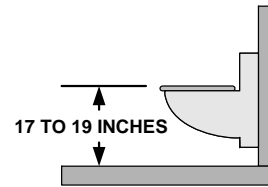

155. There are at least 18 inches of clear space from the center of the toilet to the wall(s) on either side. Yes No N/A

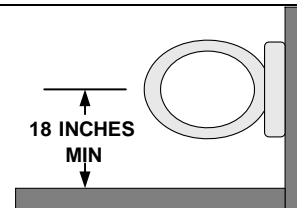

Note: Make measurement to

---

adjacent wall. Do not include objects such as toilet paper dispensers in your measurement.

---

156. The window or ledge where urine samples are placed is no higher than 48 inches and is operable with a closed fist.

Yes

No

N/A

Mark "N/A" if no window or ledge is available.

---

(Proceed to next section!!)



---

**FOR TOILET ROOMS WHERE LAB SPECIMENS ARE COLLECTED ONLY**

**(Mark "N/A" if lab specimen collection toilet rooms do not exist or if room floor plan is not applicable.)**

---

157. Where the toilet is approached from the front and there is a sink alongside the toilet, there is clear floor space of at least 48 inches wide by 66 inches long (toilet wall to opposite wall).
- Yes  
 No  
 N/A

Note: If door swings inward, measure space clear of door swing. This is easiest done with 2 people.

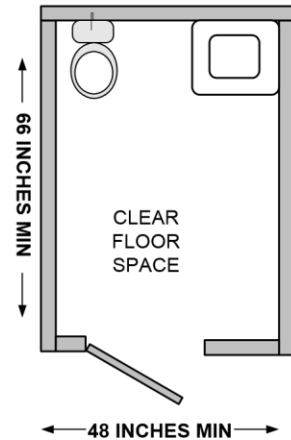

158. Where the toilet is approached from the side and there is a sink alongside the toilet, there is clear floor space of at least 48 inches wide by 56 inches long (toilet wall to opposite wall).
- Yes  
 No  
 N/A

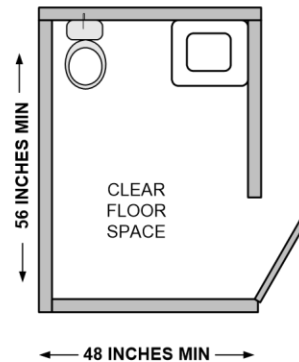

159. Where there is no sink alongside the toilet, there is a clear floor space of at least 60 inches wide by 56 inches long (toilet wall to opposite wall).
- Yes  
 No  
 N/A

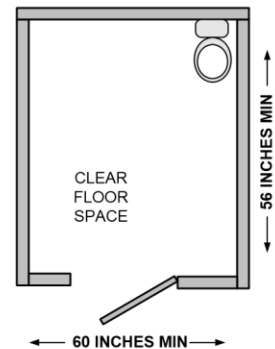

<b>NOTES : TOILET ROOMS WHERE LAB SPECIMENS ARE COLLECTED</b>	
_____	
_____	
_____	
_____	
_____	
_____	
_____	
_____	
_____	
_____	
_____	

Appendix A: Parking Requirements

Total Parking Spaces:	Required Minimum Number of Spaces:
1 to 25	1
26 to 50	2
51 to 75	3
76 to 100	4
101 to 150	5
151 to 200	6
201 to 300	7
301 to 400	8
401 to 500	9
501 to 1000	2% of total
1001 and over	20 plus 1 for each 100 over 1000

*Number of required parking spaces for outpatient units and facilities: **10 percent of the total number** of parking spaces provided serving each such outpatient unit or facility. **Note: When calculating the number of accessible spaces needed, round the number up to the next whole number if the number comes out unevenly. For example, if a lot has 83 spaces, 10 percent would be 8.3 spaces. It is required that the partial number be rounded up, so the number of spaces needed is 9.***

Appendix E: Individual Clinic OHCUP Results

OHCUP Scores out 159

ID	Over all Score	Mobility Score	Sensory Score	Cognitive Score
A	140	108	34	8
B	149	115	38	8
C	132	99	36	6
D	134	101	35	8
E	125	93	34	7
F	134	107	34	5
G	137	102	37	8
H	125	98	29	8
I	112	81	33	5
J	133	100	35	6
Mean	132.1	100.4	34.5	6.9
% OHCUP Scores %	83.0%	82.98%	84.15%	86.25%
A	88.0%	89.26%	82.93%	100%
B	93.7%	95.04%	92.68%	100%
C	83.0%	81.82%	87.80%	75%
D	84.2%	83.47%	85.37%	100%
E	78.6%	76.86%	82.93%	88%
F	84.2%	88.43%	82.93%	62.50%
G	86.1%	84.30%	90.24%	100%
H	78.6%	80.99%	70.73%	100%
I	70.4%	66.94%	80.49%	63%
J	83.6%	82.64%	85.37%	75%
Mean %	83.0%	82.98%	84.15%	86%

NA/Adjusted Score

A	81.0
	0%
B	89.0
	0%
C	72.0
	0%
D	75.0
	0%
E	66.0
	0%
F	74.0
	0%
G	81%
H	71%
I	52%
J	73%
Mean	73%

Individual Section Scores

	Parking Score	Approach to building	Ramps	Signage	Controls	Doors	Telephones
A	7	9	6	8	2	7	7
B	6	9	6	11	2	6	7
C	6	10	4	10	1	6	7
D	3	10	5	11	2	5	7
E	6	10	6	10	1	5	7
F	5	10	6	10	2	6	7
G	5	9	6	10	2	6	7
H	6	9	5	7	2	7	7
I	3	8	5	9	1	5	7
J	7	10	6	11	2	6	7
Total	54	94	55	97	17	59	70
Mean	77.14%	94%	92%	74.62%	85.00%	84.29%	100%

Percent Value

A	100%	90.00%	100.00%	61.54%	100.00%	100.00%	100.00%
B	85.71%	90.00%	100.00%	84.62%	100.00%	85.71%	100.00%
C	85.71%	100.00%	66.67%	76.92%	50.00%	85.71%	100.00%
D	42.86%	100.00%	83.33%	84.62%	100.00%	71.43%	100.00%
E	85.71%	100.00%	100.00%	76.92%	50.00%	71.43%	100.00%

F	71.43%	100.00%	100.00%	76.92%	100.00%	85.71%	100.00%
G	71.43%	90.00%	100.00%	76.92%	100.00%	85.71%	100.00%
H	85.71%	90.00%	83.33%	53.85%	100.00%	100.00%	100.00%
I	42.86%	80.00%	83.33%	69.23%	50.00%	71.43%	100.00%
J	100.00%	100.00%	100.00%	84.62%	100.00%	85.71%	100.00%
Mean	77%	94.00%	91.67%	74.62%	85.00%	84.28%	100.00%

	Counters	Passageways	Water Fountains	Lifts	Elevators	Stairs	Restrooms
A	2	7	2	6	13	5	17
B	1	7	3	6	13	5	18
C	1	7	3	6	13	5	10
D	1	7	3	6	13	3	16
E	1	5	2	6	13	5	11
F	1	7	3	6	13	5	15
G	1	7	3	6	11	5	17
H	1	7	3	6	7	5	14
I	1	6	3	6	13	5	11
J	1	7	3	6	13	5	13
Mean	11	67	28	60	122	48	142
	55%	95.71%	93.33%	100%	93.85%	96%	71%

A	100.00%	100.00%	66.67%	100.00%	100.00%	100.00%	85.00%
B	50.00%	100.00%	100.00%	100.00%	100.00%	100.00%	90.00%
C	50.00%	100.00%	100.00%	100.00%	100.00%	100.00%	50.00%
D	50.00%	100.00%	100.00%	100.00%	100.00%	60.00%	80.00%
E	50.00%	71.43%	66.67%	100.00%	100.00%	100.00%	75.00%
F	50.00%	100.00%	100.00%	100.00%	100.00%	100.00%	55.00%
G	50.00%	100.00%	100.00%	100.00%	84.62%	100.00%	85.00%
H	50.00%	100.00%	100.00%	100.00%	53.63%	100.00%	70.00%



I	50.00%	85.71%	100.00%	100.00%	100.00%	100.00%	0%	55.00%
J	50.00%	100.00%	100.00%	100.00%	100.00%	100.00%	0%	65.00%
Mean	55.00%	95.71%	93.33%	100.00%	93.83%	96.00%	0%	71.00%

	Toilet Rooms	Emergency Egress	Exam Rooms	Lab Specimen Collection Room
A	3	8	8	17
B	3	8	8	23
C	2	7	8	18
D	3	8	7	19
E	3	6	7	14
F	3	6	5	18
G	2	8	7	19
H	2	8	7	15
I	3	4	3	12
J	2	6	6	15
Mean	26	69	66	170
	86.67%	86.25%	73.34%	70.83%

A	100.00%	100.00%	88.89%	70.83%
B	100.00%	100.00%	88.89%	95.83%
C	66.67%	87.50%	88.89%	75.00%
D	100.00%	100.00%	77.78%	79.17%
E	100.00%	75.00%	77.78%	58.33%
F	100.00%	75.00%	55.56%	75.00%
G	66.67%	100.00%	77.78%	79.17%
H	66.67%	100.00%	77.78%	62.50%
I	100.00%	50.00%	33.33%	50.00%
J	66.67%	75.00%	66.67%	62.50%
Mean	86.67%	86.25%	73.34%	70.83%

Survey Results

Type of Precerti+AC2:AJ 14ce	Age of Building	Educatio n of Admin	Years experience	Knowledge Test Score
Doctors Office	2000-2009	Bachelor	1 to 5	0.8
Doctors Office	2000-2009	Bachelor	1 to 5	0.8
Hospital Community Health Center	1950-1959 earlier than 1950	Master	16 to 20	0.8
Specialist Clinic	1980-1989	Master	1 to 5	
Doctor's Office	2010-2018	Master	1 to 5	
Doctor's Office	2000-2009	Master	1 to 5	
Doctor's Office	1990-1999	Master	1 to 5	
General Outpatient	Earlier than 1950	Master	6 to 10	
Doctor's Office	1980-1989	Professio nal	6 to 10	0.8

Doctors Office	2000-2009	Bachelor	1 to 5	0.8
Doctors Office	2000-2009	Bachelor	1 to 5	0.8
Hospital Community Health Center	1950-1959 earlier than 1950	Master	16 to 20	0.8
Specialist Clinic	1980-1989	Master	1 to 5	
Doctor's Office	2010-2018	Master	1 to 5	
Doctor's Office	2000-2009	Master	1 to 5	
Doctor's Office	1990-1999	Master	1 to 5	
General Outpatient	Earlier than 1950	Master	6 to 10	
Doctor's Office	1980-1989	Professio nal	6 to 10	0.8
				0.8