

2014

Development of a Remote Laboratory with the Integration of Cloud Applications

Jeremy Thompson
West Virginia University

Follow this and additional works at: <https://researchrepository.wvu.edu/etd>

Recommended Citation

Thompson, Jeremy, "Development of a Remote Laboratory with the Integration of Cloud Applications" (2014). *Graduate Theses, Dissertations, and Problem Reports*. 213.
<https://researchrepository.wvu.edu/etd/213>

This Thesis is protected by copyright and/or related rights. It has been brought to you by the The Research Repository @ WVU with permission from the rights-holder(s). You are free to use this Thesis in any way that is permitted by the copyright and related rights legislation that applies to your use. For other uses you must obtain permission from the rights-holder(s) directly, unless additional rights are indicated by a Creative Commons license in the record and/ or on the work itself. This Thesis has been accepted for inclusion in WVU Graduate Theses, Dissertations, and Problem Reports collection by an authorized administrator of The Research Repository @ WVU. For more information, please contact researchrepository@mail.wvu.edu.

Development of a Remote Laboratory with the Integration of Cloud Applications

Jeremy Thompson

**Thesis submitted
to the College of Engineering and Mineral Resources
at West Virginia University**

in partial fulfillment of the requirements for the degree of

**Masters of Science in
Mechanical Engineering**

**Marvin Cheng, Ph.D., Chair
Bruce Kang, Ph.D.
David Miller, Ph.D.**

Department of Mechanical Engineering

**Morgantown, West Virginia
2014**

**Keywords: Remote Laboratory, Distance Learning
Copyright 2014 Jeremy Thompson**

Abstract

Development of a Remote Laboratory with the Integration of Cloud Applications

Jeremy Thompson

Distance learning has been a mode of education since its inception at Pennsylvania State University in 1892. What started as a simple correspondence course has blossomed into a globally accepted method of education. The need for remote laboratories is growing as more lab-intensive programs of study are searching for a distance learning alternative. The goal of this research is to establish the foundation of a remote laboratory in the Mechanical and Aerospace Engineering Department at West Virginia University. The main objectives are to develop simple, easy-to-use graphical user interfaces to enhance the understanding of several concepts presented in the MAE 244: Dynamics and Strength of Materials course and to increase accessibility to data outside of the lab. The integration of cloud applications with access to social media is a unique feature of this research and the key to improved accessibility. Students were asked to participate in a study in which they compared the traditional lab procedure to the procedure utilizing the developed interface for several experiments. The participants were required to fill-out surveys following each experiment and the responses were unsurprisingly positive. Further works based on this research should include more quantitative results and include more experiments with more students to get a more accurate portrayal of the student body. Overall, the research was successful in ascertaining that the developed interfaces were a beneficial addition to the experiments and did, in fact, greatly improve the accessibility to data.

Acknowledgements

First and foremost, I would like to thank God for giving me the ability to succeed and the strength to persevere during the difficult times.

I thank my family and friends for their tremendous support throughout the entirety of my life but especially the last 18 months. They offered financial, emotional, and physical support throughout this endeavor. Special thanks to my grandmother, Edna Thompson, and my girlfriend, Stephanie Singleton.

I would also like to thank the selection committee at Statler College of Engineering and Mineral Resources that afforded me the opportunity to show that I was capable of completing this degree.

I would like to thank all of the faculty members that helped along my journey. I would especially like to thank Dr. Bruce Kang for allowing me to work on this research and for serving on my committee. Along the same lines, I am grateful to have been able to work with Dr. Marvin Cheng who served as my advisor and committee chair and really pushed me to get things done. I owe a special thank you to Dr. David Miller for helping me with the educational aspect of this research and agreeing to serve on my committee.

Lastly, I was fortunate to find enough willing participants to complete this research and to each and every one of them I am extremely thankful.

Table of Contents

Abstract	ii
Acknowledgements	iii
Table of Contents	iv
List of Tables	vii
List of Figures	viii
Chapter 1: Introduction	1
1.1 Overview	1
1.2 Motivation	2
1.3 Objectives	4
1.3 Organization of This Document	5
Chapter 2: Background and Literature Review	6
2.1 Introduction	6
2.2 Distance Learning	10
2.2.1 History of Distance Learning	10
2.2.2 Evolution of Distance Learning	11
2.2.3 Challenges of Distance Learning	13
2.2.4 Hands-Off Laboratories	17
2.3 Laboratories in Engineering Education	17
2.3.1 Evolution of Engineering Laboratories	19
2.3.2 Laboratory Type Comparison	21
2.4 Integration of Cloud Platform	26
2.5 Conclusion	27
Chapter 3: Technical Approach	29
3.1 Introduction to MAE 244	29
3.2 Problem Statement	31
3.3 Setup of Hardware/Software	34
3.3.1 P3 Strain Gage Hardware/Software	34
3.3.2 Microsoft Visual Studio 2010	37
3.3.3 Google Service	38
3.4 Application Overview	39

3.4.1 Integration of Hardware and Software	39
3.4.2 Thought Process of Interfaces	40
3.4.3 Experiment Requirement Comparison	41
3.4.4 Programming Techniques.....	44
3.4.5 Live Video Stream.....	46
3.5 Beam Bending	46
3.5.1 Equipment.....	48
3.5.2 Interface Development	49
3.5.3 Lab Procedure Comparison	52
3.5.4 Summary.....	54
3.6 Combined Loading	55
3.6.1 Equipment.....	57
3.6.2 Interface Development	58
3.6.3 Lab Procedure Comparison	61
3.6.4 Summary.....	62
3.7 Pressure Vessel.....	63
3.7.1 Equipment.....	65
3.7.2 Interface Development	66
3.7.3 Lab Procedure Comparison	68
3.7.4 Summary.....	70
3.8 Tension Test	71
3.8.1 Equipment.....	72
3.8.2 Interface Development	74
3.8.3 Lab Procedure Comparison	76
3.8.4 Summary.....	78
3.9 Incorporation of Cloud Storage and Social Media.....	79
3.10 Conclusion.....	82
Chapter 4: Responses from Students	83
4.1 Beam Bending Student Survey Responses.....	83
4.2 Combined Loading Student Survey Responses	90
4.3 Overall/General Student Survey Responses	96
Chapter 5: Conclusion.....	105

5.1 Contribution of This Work	105
5.2 Achievement of Integrating Works	105
5.3 Technical Difficulties and Deviation from Original Plan	108
5.3.1 Tension Test	108
5.3.2 Pressure Vessel.....	109
5.3.3 Google API.....	110
5.3.4 USB Connection.....	110
5.4 Future Works.....	111
5.4.1 Quantitative Results.....	111
5.4.2 Administrator Survey	113
5.4.3 Administrator Interface	113
5.4.4 Cloud Automation	113
5.4.5 Interface Improvements.....	115
5.5 Overall Summary	115
Bibliography	117
Appendix A	119
Appendix B	121
Appendix C	125
Appendix D	130
Appendix E	137

List of Tables

Table 2-1: Comparison of Different Types of Laboratories	22
Table 2-2: Another Lab Type Comparison.....	24
Table 3-1: Requirement Comparison.....	43
Table 3-2: Chart for Beam Bending Data Recording	53
Table 3-3: Chart for Combined Loading Data Recording	61
Table 3-4: Chart for Pressure Vessel Data Recording	69
Table 3-5: Chart for Tension Test Data Recording	77
Table 4-1: Comparison of Likert Scale Survey Questions.....	103

List of Figures

Figure 2-1: Graphical User Interface for NetLab	8
Figure 2-2: Screenshot from WebLab.....	Error! Bookmark not defined.
Figure 2-3: Configuration of Typical Setup of Remote Lab.....	27
Figure 3-1: Diagram of Networked Laboratory.....	33
Figure 3-2: Model P3 Strain Gage Indicator and Recorder Hardware	35
Figure 3-3: Visual Studio Workspace.....	Error! Bookmark not defined.8
Figure 3-4: Integration of Hardware and Software.....	36
Figure 3-5: Flow Chart of the Program.....	452
Figure 3-6: Schematic of Cantilever Beam for Beam Bending Experiment	47
Figure 3-7: Beam Bending Experimental Setup	488
Figure 3-8: Beam Bending Interface.....	50
Figure 3-9: Combined Loading Top-View Schematic.....	56
Figure 3-10: Combined Loading Experimental Setup	57
Figure 3-11: Combined Loading Interface	579
Figure 3-12: Pressure Vessel Schematic.....	64
Figure 3-13: Pressure Vessel Experimental Setup.....	65
Figure 3-14: Pressure Vessel Interface	67
Figure 3-15: Tension Test Schematic	72
Figure 3-16: Tension Test Experimental Setup	73Error! Bookmark not defined.
Figure 3-17: Tension Test Interface.....	74
Figure 4-1: Beam Bending Question 3	84
Figure 4-2: Beam Bending Question 4	825
Figure 4-3: Beam Bending Question 6	836
Figure 4-4: Beam Bending Question 2	847
Figure 4-5: Beam Bending Question 1	869
Figure 4-6: Combined Loading Question 4	91
Figure 4-7: Combined Loading Question 5	92
Figure 4-8: Combined Loading Question 2	903
Figure 4-9: Combined Loading Question 1	914
Figure 4-10: General Question 5.....	98
Figure 4-11: General Question 4.....	969
Figure 4-12: General Question 6.....	100
Figure 4-13: General Question 8.....	101
Figure 4-14: General Question 7.....	992

Chapter 1: Introduction

1.1 Overview

Distance Learning has grown significantly in the last few decades for several reasons; a main reason being that many people who are already in the work force need a new or different degree for various reasons but cannot afford to quit their job. With that in mind, colleges and universities that wish to stay competitive in the distance learning realm need to continually be creating and improving their distance learning programs. Obviously, there are some curricula that make it easier than others to provide a distance learning option. For example, it can be challenging to implement a distance learning program for an engineering curricula; one of the main reasons for this difficulty is the need for hands-on laboratories.

The importance of the laboratories in the engineering curriculum is considerably less than in the past [11]. There is a movement towards reinstating the lab to its former glory; and, if successful, there will need to be a strong emphasis on creating distance laboratories in order fulfill the necessary laboratory requirements within the modern engineering curriculum for accreditation of a distance learning program. There are two different types of distance learning laboratories: remote and virtual. The importance of the lab in the engineering curriculum and the different types of laboratories will be discussed in Chapter 2. Depending on the type of laboratory and the experiments associated with it, it may not be possible to create a totally distance-based laboratory option for some of the required laboratories in the engineering curriculum.

The plan for this research was to lay the foundation of a remote laboratory for the Mechanical and Aerospace Engineering program at West Virginia University. The goal of this research is to integrate a traditional laboratory environment with state-of-the-art technology, including cloud service and mobile technology. Both students and instructors can benefit from the innovative online laboratory as it can reduce the time of setting up and performing experiments. The broadest description of our plan is that graphical user interfaces were created for some experiments in a Strength and Dynamics Laboratory to help with data acquisition by using Excel and sharing of data files by utilizing Google Drive. More specifically, each of the experiments that use a P3 Strain Indicator and Recorder from Micro-Measurements will have an interface that will pull the readings from the P3 device into an Excel worksheet, as well as the other parameters for the experiment, and then that Excel worksheet will be saved into Google Drive Desktop which, in turn, will allow the data to be shared with each member of the group almost instantaneously. The interfaces should be easy to use and understand and the Teaching Assistant or Instructor has only to set the sharing controls at the beginning of the course and Google Drive will do the rest.

1.2 Motivation

The purpose of this research is to provide the foundations of a remote engineering laboratory at West Virginia University. This would potentially allow for the creation and development of a distance learning engineering curriculum with a remote laboratory which could provide a first-rate Mechanical Engineering education to many more people far outside the borders of the great state of West Virginia. The motivating factors of this research are to allow

students to perform experiment more quickly and efficiently in an effort to enhance the learning experience as well as create the capability to share resources with other institutions to reduce costs. One aspect of this project that differs from most remote labs that have already been started or completed, is the integration of cloud storage technology and social media.

Most laboratories, in most universities, require the students to be in groups because there simply is not enough room and/or space to allow each student to perform each experiment individually. In many cases, laboratories are also extremely expensive to equip and by creating a remote laboratory, other institutes can access the laboratory remotely and help share the cost of creating and maintaining the laboratory. These two topics will be discussed in detail in Section 2.4. Using cloud storage allows the students to access their results anywhere they have access to the internet and by utilizing social networks they can communicate and share data to improve the efficiency of writing the laboratory reports. Not only does utilization of cloud storage technology and integration of social media make storing and sharing data more effective, it also adds a little fun and allows students to display their results with their friends and family thus potentially growing the interest in engineering as whole.

1.3 Objectives

The major objectives of the development of this remote laboratory are to integrate lab resources with modern technologies and improve the efficiency of performing the lab and report writing. The objectives are specifically stated as follows:

1. *Create user-friendly interfaces for select laboratory experiments to enhance the data acquisition process.* One of the primary concerns for this research is to improve the way

students are able to extract data from these experiments but not to complicate the process. Ideally, the process should also be simplified.

2. *Integrate cloud storage technology with laboratory experiment results.* Currently, students must have a flash storage device to transport the data from the laboratory to wherever they will be writing their report. Each student must have their own or one student has to get the data and then share it with the other members of the group. By integrating cloud storage into the user interfaces each student will have the data available to them as soon as the experiment is over and anywhere that they have access to the internet.
3. *Improve the efficiency and effectiveness of students during the experiment by means of the user-friendly interface.* Presently, students have to perform the experiments in a group so that some students can adjust the equipment as necessary while others write down the data and then the others copy that data. Not only does this give each student a different perspective on the experiment but it also takes more time than should be required. By implementing the user interface, each student can participate and focus on the actual experiment that is taking place and everyone will still get the same data because of the previous bullet point.
4. *Improve the efficiency and effectiveness of the students during the laboratory report writing process due to the utilization of the cloud storage.* As mentioned previously, students now have to use flash storage devices to carry around their data and then import the data into Excel. By using the interfaces, they have access to the data anywhere that has internet and it is already in an Excel format.

1.4 Organization of This Document

In Chapter 2, the history and background of remote laboratories will be discussed. Some specific topics covered in this chapter include the history and evolution of distance learning, the role of the lab in the engineering curriculum both past and present, and, lastly, a comparison of different types of remote laboratories. The third chapter discusses the technical approach taken for this research. It begins with an introduction to the platform used for this research, followed by the hardware and software used throughout the process, then a general comparison between the experiments selected for this research, and, finally, each experiment and interface is discussed in detail. Chapter 4 contains the results of the research which are the student survey responses. The final chapter presents the conclusions drawn from this study, several of the difficulties encountered throughout the process, and the potential future works related to this research.

Chapter 2: Background and Literature Review

2.1 Introduction

Distance learning has become a more accepted means of obtaining a higher education degree in the past few decades. Although most people may think that distance learning is relatively new, and a direct result of the internet, distance learning has actually been around for over 100 years. The fast pace and financial obligations of today's world can make it difficult for a person to enroll in an on-campus educational experience; for some, however, it is a choice to forego the on-campus experience. Some of the main reasons people are attracted to distance learning, especially those that have already entered the work force, can be summarized as follows [8]:

- Non-Traditional Experience;
- Location Convenience;
- Schedule Flexibility; and
- Cost.

Like distance learning itself, these reasons are not new but are similar to the reasons why distance learning was created. With the increasing interest in distance learning, universities and colleges are having to overcome the obstacles associated with distance learning in order to create distance learning programs if they wish to compete in this emerging area of education.

Although distance learning definitely has some advantages, it does not come without consequences. The policies and procedures that institutions have in place are based on traditional, on-campus programs of study. Distance learning adds something totally different that requires the administration to review their policies and procedures and make modifications

where necessary. One area of policies that has to be modified is how instructors are evaluated because different things are required to run a successful online class and the interaction with the students is considerably different. On a similar note, students that take online courses need to take a different approach in order to be successful and it is up to the institution to make sure the students are well informed of what is required of them. With that in mind, the institution needs to allocate the necessary resources to assure that the quality of the course is similar to the alternative offered on campus. Most of these issues can be handled if they are addressed early on in the development of distance learning courses. The issues mentioned above apply to all distance learning courses but there are some courses that have additional problems that need to be considered.

While the majority of distance learning courses vary only in the delivery of the material from those offered in the classroom; there are some courses that are more difficult to convert to a distance learning alternative. One example of this, and the one that this research will be focusing on, is an engineering course that has a lab requirement. In order for the program to gain accreditation, every course would have to meet the accreditation criteria and this means that the courses that require a lab would need to fulfill this requirement “from a distance”. An understanding of the role of the laboratory in the engineering curriculum is important when considering an alternative type of laboratory because it is imperative that the integrity of the laboratory is not sacrificed. Remote laboratories are not necessarily new but they have been getting more attention lately and are paramount for any program of study that requires any labs to obtain accreditation. Some examples of remote engineering laboratories are given below.

NetLab – “NetLab is a remote laboratory specialized for experiments in electrical circuits and systems. It has a specially designed Graphical User Interface that

uses photographic images of laboratory instruments with animated controls and displays. This enables students to control the instruments in the same way as if they were working in the real laboratory” [7]. Access is available via the Internet.

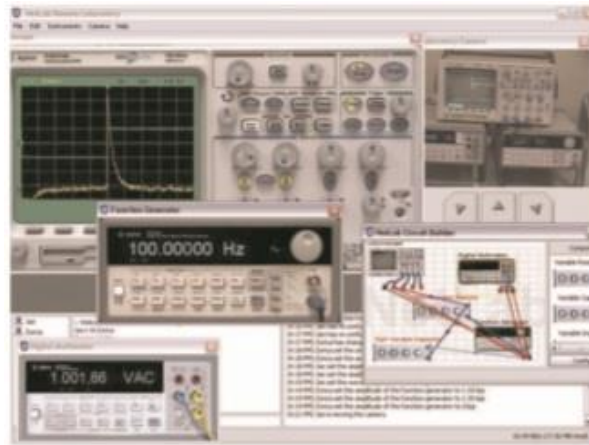

Figure 2-1: Graphical User Interface for NetLab [7]

WebLab – “WebLab...allows students to do actual (not simulated) laboratory research on state-of-the-art equipment though the Internet” [6]. WebLab consists of laboratory instruments for the characterization of microelectronic devices, together with computer hardware and software that makes this equipment accessible to users through the World Wide Web” [6]. “It enables them to use different processes of learning (intuitive, visual, abstract), and it gave them an opportunity to link individual and collaborative effort in creative combinations” [6].

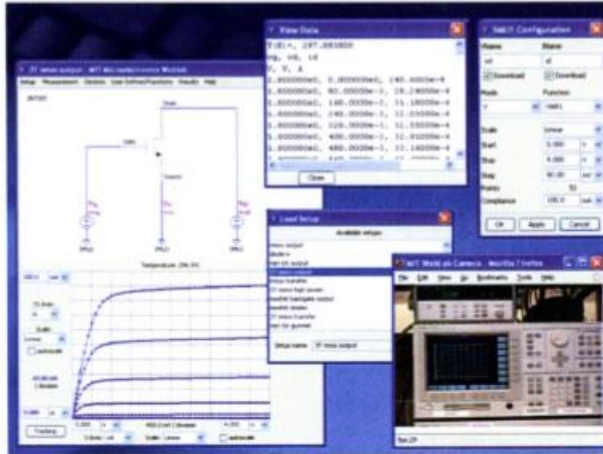

Figure 1-2: Screenshot from WebLab [6]

These two laboratories might provide the same hands-on function in an engineering course but their approaches are very different. One is a simulated environment, NetLab, and the other one, WebLab, is a real experimental setup with a network connection. Clearly, there are two types of distance learning laboratories that can be considered but they are both attempting to fill the same hole in a distance learning program that has laboratory requirements. The first type is a virtual laboratory that uses a simulation of the experimental setup to produce results and the second type is a remote laboratory that uses a remote connection to control the physical lab setup to produce results. Most of the existing on-line engineering courses with laboratory experience adopt one of these two approaches. The ultimate goal of distance learning is to provide access to many people that have a desire to obtain a higher level of education without limiting their options and sacrificing the integrity of the degree they are seeking to acquire.

2.2 Distance Learning

According to Google [13], distance learning is “a method of studying in which lectures are broadcast or classes are conducted by correspondence or over the Internet, without the student’s needing to attend a school or college”. Distance Learning started in Pennsylvania in the late 1800’s [8]. Although distance learning has evolved since its inception, many of the reasons people participate in distance learning are the same. Distance learning is not without its downfalls; there are several issues that need to be considered by the administration, the faculty, the students, and the institution to ensure that the distance learning experience is successful [8]. As communication technology continues to improve, there is no doubt that distance learning will become a monumental part of education worldwide.

2.2.1 History of Distance Learning

The domestic origin of distance learning, or distance education, “can be traced to the development of correspondence study at Pennsylvania State University in 1892” [8]. The original correspondence program developed at Penn State was done so to allow the rural population that desired higher education to be able to complete the necessary degree requirements while still being able to work and support a family [8]. The reasons people participate in distance learning today are the same reasons that distance learning was created in the first place. In fact, given the speed at which life must be lived in today’s society, these reasons are also why the popularity of distance learning is increasing so dramatically. Obviously, the means of communication between the institution, instructor, and students, have changed radically which is another reason for the substantial increase in enrollment in distance learning courses.

2.2.2 Evolution of Distance Learning

The demographic of the higher education student population has changed dramatically over the last several decades and this is just one reason for the increased popularity of distance learning. According to Institute of Education Sciences [12], only 6.4 million of the 19.1 million students, or approximately 34%, are full-time between the ages of 18 and 22 in 2008. That number is down considerably from 1970 when almost 47% of students were full-time and between the ages of 18 and 22 [12]. Consequently, the number of students enrolled above the age of 25 in 2008 was 8 million (42.2%), a significant increase from 1970 when only 27.8% of students were older than 25 years of age [12]. Over 20% of the students enrolled at an “institution participating in the Title IV programs” in 2008 had, at a minimum, one distance learning course and almost 4% were working a degree entirely through distance education [12]. These statistics suggest that people are either having to go back to college after they have started a career or that they are delaying college until later in life and many of them are choosing distance education as a means to complete at least some of their degree requirements. Technological advancements have allowed more people to take advantage of distance learning programs.

The non-traditional experience appeals to two types of prospective students: those that cannot afford the traditional experience and those that prefer the non-traditional experience. People that want to go back to school but cannot stop working due to financial obligations need the non-traditional experience because their available time is very limited; with more people going back to school after they have already entered the work force, this is a huge advantage of distance learning. Those that prefer the non-traditional experience may be able to afford the

traditional experience but perhaps do not want to deal with the social aspect of it. Whether they cannot afford to attend school in a traditional manner or just prefer not to, the fact that they can obtain a degree “outside of the classroom” is why people turn to distance learning programs.

The Internet has made the non-traditional experience as close to traditional as it has ever been and is also the reason that students can have access to their course almost anywhere in the world. Travel has become an integral part of today’s society, whether it is for business or pleasure, it seems that more people are traveling now than ever. The convenience of not being forced to be in one spot is another reason why people prefer a distance learning course to an in-class course. The location convenience offered by distance learning ties into the next reason people participate in distance learning: schedule flexibility.

As mentioned before, the pace at which one must live to be successful in today’s society does not leave much free time. The ability to be able to “go to class” when people can fit it into their busy schedules is one of the biggest draws to distance learning programs. There are still deadlines, but people have the freedom to choose their schedule and vary it whenever necessary. Not only does distance learning provide several different types of “freedom” for its students, it is also cheaper than the “on-campus” alternative.

The cost of distance learning programs is another reason people today choose distance learning over traditional higher education experiences. According to Banas and Emory [8], in the mid-1990’s, “At the University of Phoenix, a for-profit educational institution, the cost of providing one credit hour of distance education is \$237 compared to \$486 for one credit hour of traditional education at the not-for-profit Arizona State University”. The “per labor hour cost” is also significantly lower at the University of Phoenix at \$46 compared to \$247 at Arizona State University [8]. The reason the University of Phoenix has lower costs is because they do not have

to build or maintain residence and dining halls, support low-enrollment programs or high-cost programs such as lab sciences, and they do not have to support faculty research [8]. Due to the lower cost, some questions are raised about the quality of the education and some other problems that distance learning may possess.

2.2.3 Challenges of Distance Learning

Although the effectiveness of a distance learning approach may be questioned, studies have found that there is no significant difference in the learning outcomes when compared to a traditional learning experience [8]. The fact that distance learning programs are academically effective bodes well for the continued growth and interest in distance learning. Even though the concern for the quality of the education in a distance learning program is unwarranted, there are some real issues to be considered with distance learning and they can be categorized as follows: administrative, faculty, student, and institutional [8].

Administrative problems are those that involve the governing bodies at an institution. Due to the popularity of distance learning, administrators are feeling pressure to at least integrate distance learning programs into traditional curricula to stay competitive. This means that all policies, infrastructure, and resource allocations need to be reviewed and modified if necessary. The policy review is necessary to remove any policy that may hinder the incorporation of distance learning into the traditional education experience. A few of the main infrastructure issues that need to be considered are: “fee assessment, out-of-state versus in-state fees, and access to technology by faculty and students” [8]. Unless the institute has a surplus of funds available, resources will need to be reallocated in order to support the new distance learning

programs. Accreditation is a key concern that the administrators need to consider when implementing a distance learning program. The accreditation requirements for distance learning are noticeably different than those for traditional learning [8]. The recognition criteria for faculty members would also need to be altered since the requirements for teaching a distance learning course are considerably different than those for teaching a traditional style course; compensation and tenure are only two such areas.

Some *faculty* issues overlap with the administrative issues. Teaching a distance learning course is not the same as teaching a traditional class. Because there is, at most, limited face-to-face interaction between the students and the instructor, the delivery of the material must be altered to maintain its effectiveness. Faculty undertaking a distance learning course need support from several people and professional development before they can be an effective distance learning instructor. When the instructors are designing, or redesigning, a course the delivery technology that is being used is one of the most important factors to consider. Because of the need of a larger support system, instructors may feel a loss of control. Some other concerns a faculty member may experience involve incentives, rewards, evaluations, tenure, and promotions; and, the best way to combat these is to define how things are going to work early on in the development of these programs. Due to the reliance on technology, which can sometimes be unreliable, the instructor or the student may feel that the instructor is responsible for poor delivery during technical difficulties. These issues may affect how students rate the quality of the instruction which falls on the instructor. The last issue that the faculty may be concerned about is who owns the developed course material. Intellectual property rights are a big issue in higher education systems.

Students have their own issues to deal with as well. The best way to avoid issues with students in a distance learning program is to provide them with an adequate amount of information up front about what they should expect and what is required of them for successful completion of the course. Students need to have access to all technology and institutional and course information. However, students cannot access resources physically in most cases; thus, student isolation is a major concern not only for the student but also for the institution. The lack of student-to-student interaction can cause the students to lose focus and consequently not perform as well as each party would like. Some ways to remedy this include cameras for each student for video conference type interaction. With this type of interaction, the faculty also needs a monitoring system to preserve the integrity of the course. Because of the personal flexibility that distance learning offers to the students, it can be easy for them to think that they should have full-time access to the instructor (7 days/week, 24 hours/day) and when there is a delay in the response time from the instructor the student may become frustrated. This is why distance learning etiquette education is necessary. It is also important for the students to know who they can talk to about different issues. For example, they should know which issues they need to contact the institution and which ones are the responsibility of the instructor. The lack of student-faculty interaction can also become an impeding factor in the overall learning outcomes of the course.

The institution is responsible for providing technological support for the students and the faculty. As mentioned in the previous section, the relationship with the faculty members needs to be defined early on and the institute needs to collaborate with the faculty in the development and maintenance of the distance learning course. They also need to find a way to reduce the “loss of control” felt by the instructor and ways to provide opportunities for student-to-student

interactions. Most importantly, they need to understand the limitations of distance learning and the technology being used, especially for delivery of material, so that reasonable and attainable goals are established.

2.2.4 Hands-off Laboratories

While creating distance learning courses for most programs of study is only a matter of adjusting the material based on the delivery technology; creating distance learning courses for programs of study in some of the STEM areas may be considerably more difficult because of the lab requirements. For example, providing the theory of engineering via an online medium is no more of a challenge than any other course but providing all of the necessary labs (i.e. strengths and dynamics, electronics, Mechatronics, etc.) requires more extensive development. It requires the development of “hands-off” laboratories; “Hands-off” refers to the fact the students do not physically interact with the experimental equipment. “Hands-off” laboratories can be further divided into remote laboratories and virtual laboratories; both types of “hands-off” laboratories are very important to distance learning. In order to obtain accreditation the engineering distance learning program needs to show that they are able to successfully provide the required learning outcomes from the laboratories. In order to do that, the learning outcomes from each lab needs to be clearly defined and in order to do that the role of the laboratory in the entirety of the curriculum needs to be understood.

2.3 Laboratories in Engineering Education

As stated by Feisel and Roase, “Engineering is a practical discipline” [11]. With that in mind, it would make sense that practice “doing” should be more important than theory; and, prior to the creation of engineering curricula in schools and universities, engineers were trained in an apprenticeship program environment [11]. This means that all of the “education” they received was hands-on training. As engineering programs were developed in schools, theory was added to the hands-on practice and a balance between theory and “doing” was created. As more schools added engineering to their list of available programs, this mesh of theory and practice continued; at least until after World War II.

After World War II, many of the new innovations and inventions did not come from engineers but rather from “scientists” [11]. Because of this, many schools, if not all, began focusing more on theory and less on practice. The American Society for Engineering Education (ASEE) was responsible for this shift in focus because they deemed graduating engineers as being “too practically orientated” [11]. This committee formulated a list of what engineers should be taught throughout the curriculum and laboratories, for some reason, were not mentioned.

ABET, formerly ECPD, came about around 1980 and were in charge of the accreditation of institutions, and in order to do that, clearly defined objectives needed to be created [11]. During this time, because of the pursuit of clearly defined objectives and some other reports done by the ASEE, the importance of labs in the engineering curriculum was rediscovered. As the 20th century was starting to wind down, ABET was being criticized for their approach to accreditation which was leaving the U.S. seemingly uncompetitive from a global standpoint [11]. As a result of the pressure to improve the quality of American engineers, ABET revised their accreditation process before the new millennium. In the early 2000’s, “The Fundamental

Objectives of Engineering Instructional Laboratories” was created by a colloquy funded by the Sloan Foundation [11]. These objectives can be found in Appendix B.

At this time, these are the objectives that institutes are expected to satisfy to produce successful engineers. As this section has shown, the role that laboratories play in the engineering curriculum has changed dramatically since its inception into academia in 1802 [11]. The role of the laboratory was not the only thing changing in the lab during this time period; the lab itself was also undergoing an evolution

2.3.1 Evolution of Engineering Laboratories

Before computers, engineering laboratories were simply sessions in which students learning by doing. Everything was done manually as theory was put into practice. “The first electronic digital computer, the ENIAC, became operational in 1946 at the University of Pennsylvania” [11]. The growth of computer technology was rapid from that time forward and, even today, jumps in computer technology are common place. When computers were first introduced into the laboratory they were only used for very complex and elaborate problems because at that point, they were very slow and the process was rather tedious and lengthy to do even a simple computational processes. The HP-35, and subsequent models that followed, “replaced the traditional slide rule and gave students the capability of analyzing data with far greater speed and accuracy” [11]. When the PC, personal computer, was introduced by IBM in 1981, the laboratories again took advantage of the new technology [11]. Schools started integrating computers into many labs and creating workstations that were capable of supporting multiple courses. By the late 1980’s, computers were being used in many ways and simulators

were being created to add a new way of learning into the curriculum. Computer technology was also being incorporated into the laboratory apparatuses allowing for more complex and detailed experiments. The combination of PCs and more sophisticated equipment allowed students to explore and analyze problems in a way never before imagined.

While the PC was necessary to connect to all of the apparatuses directly in order to utilize the new technology, creating a distance learning laboratory would not have been possible without internet. The internet created a medium that allowed the PC to connect to equipment without being physically connected. Theoretically, as long as the equipment was connected to the internet and the PC was connected to the internet, it should be possible to control the equipment from the PC remotely. It was at this point in time that the idea of a “remote” laboratory came onto the scene [14].

Remote laboratories may have started as just an idea, as many things do, but that idea was brought to life through hard work and perseverance. Many advancements in the area of remotely controlled laboratories have been made in the last several decades and there are now several high-tech programs that allow for accessing laboratories remotely using a combination of hardware and software. One of the most notable of these systems is LabVIEW by National Instruments [9]. All of these technologies have effectively created two additional classes of laboratories: virtual laboratories and remote laboratories.

2.3.2 Laboratory Type Comparison

As mentioned in the previous section, several new “types” of laboratories were able to be created because of the advancement of computer technology. There are currently three

recognized types of laboratories: real laboratories, virtual laboratories, and remote laboratories. Real laboratories are the original type of laboratory and are those in which everything is done “hands-on” and computers have a limited role in the experiments. Virtual laboratories are laboratories that take advantage of computer simulation technology to provide results based on previously done experiments with similar parameters. Remote laboratories implement user interfaces connected to actual laboratory equipment that the user can control remotely to conduct the experiment. Given that the purpose of the virtual and remote laboratories is to emulate the learning outcomes of real laboratories, it is apparent that remote laboratories are the best alternative to real laboratories. A more detailed comparison is required to get a true understanding of the strengths and weaknesses of each type of lab.

Real laboratories are what people think of when they hear the word “laboratory”. Real laboratories contain the physical experiment apparatuses that are used to collect data. The use of computers in today’s real laboratories are generally limited to data acquisition and analysis. The role of computers is the main difference between real laboratories and the other two types. Remote laboratories use computers to connect to real experiment apparatuses whereas virtual laboratories use computers to perform pre-programmed simulations. A comparison among these three types of laboratories is listed in Table 2-1. Although the ultimate goal of each of these types of laboratories is the same, the each offer the participant a unique experience.

Table 2-1: Comparison of Different Types of Laboratories [9]

Laboratory Type	Advantages	Disadvantages
Real	realistic data interaction with real equipment collaborative work interaction with supervisor	time and place restrictions requires scheduling expensive supervision required
Virtual	good for concept explanation no time and place restrictions interactive medium low cost	idealized data lack of collaboration no interaction with real equipment
Remote	interaction with real equipment calibration realistic data no time and place restrictions medium cost	only "virtual presence" in the lab

Gaining hands-on experience is one of the main reasons that programs have laboratory requirements; and, this experience is obtained from the interaction with the actual laboratory equipment. Real laboratories are able to provide this type of experience and is actually required for a laboratory to be considered “real”. Remote labs are similar to real laboratories in that they allow the student to use the physical laboratory equipment albeit in more of a virtual sense. Virtual laboratories, by definition, do not connect the students to physical laboratory equipment but rather to an interface that mimics the actual equipment but provides a simulation of the experiment. The interaction between the students and the laboratory equipment is a key factor in determining the type of data the students will receive from the experiment.

The purpose of performing an experiment in a laboratory is to obtain usable data that can be analyzed and compared to theoretical results. In a real lab, the data obtained is a direct result of how the student configures the equipment and executes the experimental procedure. As such, there can be considerable variability in the results from student to student. Similar to real laboratories, remote laboratories allow the students to obtain “real” data but there are limitations on the variability due to the pre-configured options available. On the contrary, virtual labs only

produce simulated results which yields ideal data; this is good to help the student understand the concept behind the experiment but limits the actual experience received. Restrictions on experience are not the only restrictions that need to be considered in this comparison.

Real laboratories are conducted on campus, at a certain time, and in a specified location; this scheduling is essential to avoid any time or location conflicts with other courses for all the students enrolled in the laboratory. Unlike the real labs, remote and virtual laboratories do not have time or location restrictions. Because no experimental devices are involved and the data is simulated, virtual laboratories can be accessed anytime as long as there is an open station available. Remote laboratories, for the most part, do not require scheduling because the experimentation is done through the use of a network so the students need only wait for a station to become available; however, there may be times when it is necessary for a supervisor to be in the lab while the student performs the experiment.

Supervision is another area of contrast between remote and virtual laboratories and real laboratories. Virtual laboratories do not require any type of physical supervision due to the fact that they are simulated experiments. Remote laboratories would only require supervision if the experiment being performed required physical configuration of the equipment. A line of communication by email or chat software should be available for the students to ask questions while operating the remote or virtual laboratories. Real laboratories require physical supervision and the students must interact with the supervisor to attain instructions for the experiment or to get questions answered. The fact that supervision is required is one reason why students are put into groups in a real laboratory.

Table 2-2: Another Lab Type Comparison [1]

Feature	Real Lab Experiment	Remote Lab Experiment	Virtual Lab Experiment
Hands-on experience	There is nothing like a real-experiment	Very close to reality	Completely virtual
Feeling of reality	High	Reasonably high (if a camera used)	Low
Feeling of and actual control	High	Reasonably high	Reasonably high
Freedom of configuration and experimentation	Open-ended experimentation is possible. Limited by lab facilities	Limited by pre-configured options.	Limited by programmed possibilities.
Tutor support	Usually present during lab or office hours	Students can e-mail questions. Pedagogical assistants or wizards may be built in.	
Technical support	Technician availability	Student can e-mail requests	
Access times	Limited to semester timetable	Limited by set-up configuration	
Access limits	Students complete experiments in a lab period. They may have rolling lab periods.	No limits; queued access when other users are conducting experiments	
Supervision	Lab assistants may be present for questions	E-mail enquiries and discussions using chat software	
Progress check	Submitted reports can be checked throughout the semester for lab-mark assignment	Academic staff may have software access to monitor student progress, and reports on student access or performance etc. may be sent	
Pedagogical enhancement	Traditional	Suitable for local/distance learning. Pedagogical enhancement through web links, animation and virtual reality software.	

Groups allow for collaboration which emphasizes team-work and learning to work in a team is crucial for being successful in the field of engineering. Remote and virtual laboratories do not usually permit collaboration because students perform the experiment at a computer by themselves; however, it is sometimes possible to configure the remote laboratory to allow multiple students to access the equipment at the same time. In a real laboratory, the students must work together to configure the equipment and follow the experimental procedure to allow them to obtain accurate data so that they learn to work in a team towards a common goal.

Learning team-work and the fact that students require supervision in a laboratory are not the only reasons students are put into groups, cost is another factor to be considered. While learning to work as a team is necessary, students would probably learn more if they were able perform each experiment alone; however, it would cost entirely too much to allow each student to perform the experiment.

The cost for each type of laboratory varies quite significantly, with real laboratories being the most expensive and virtual laboratories being the least. As one might imagine, real laboratories cost the most because they require physical laboratory apparatuses, constant supervision, maintenance, and scheduling. Remote laboratories still require physical equipment and some maintenance but limited supervision and scheduling so they are less expense than real laboratories but still more than virtual laboratories. Virtual laboratories are obviously the cheapest type because there is no lab equipment necessary and therefore no maintenance, scheduling, or supervision. The chief cost for the virtual laboratories is the cost of creating the simulation. Each type of laboratory can be beneficial to students, the determining factor is usually the cost effectiveness for a given institution.

2.4 Integration of Cloud Platform

Technology seems to find its way into every facet of life and academic laboratories are no exception. The term “cloud” is synonymous with the Internet but, in today’s society, it seems to mean much more than that. Cloud computing, which dates back to the 1960s, “allows on-demand network access to fully configurable computing resources” [14],[15]. More simply, the “cloud” allows computational machines access to far more computing power than the machine is

capable of itself, by way of the Internet; this reduces energy consumption and expenses of the system [15]. A typical setup of a remote laboratory is illustrated in Figure 2.3. Cloud computing is associated with the following features [14]:

- The illusion of infinite computing resources available on demand.
- The elimination of up-front commitment by the cloud user.
- The ability of paying for use of computer resources on a short term basis as needed.

Employing these features, the cloud offers several types of services [14].

- Hardware as a Service (HaaS): “Access to complete computer systems, grids, or data centers. The user can install and run their own systems and software as needed.”
- Software as a Service (SaaS): “Access to software or applications. The actual hardware and platform remains completely transparent for the user”
- Data as a Service (DaaS): “Access to data for storage and semantic access over the net.

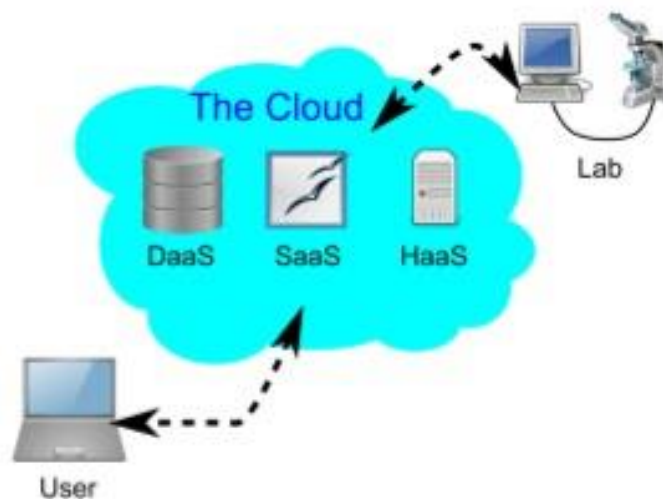

Figure 2-3: Configuration of Typical Setup of Remote Lab [14]

The “cloud” offers many advantages, but basically, it is faster and more cost and energy effective; given the limited resources institutions general have available for laboratories, it only makes sense that the “cloud” would be utilized.

2.5 Conclusion

Distance learning has been around since the end of the 19th Century. What started as a simple correspondence program in Pennsylvania has turned into a globally accepted type of learning that is capable of connecting people from all over the world, almost instantaneously. Distance learning is not without its problems but many of them can be avoided if guidelines are clearly defined in the beginning and with distance learning programs comes the need for distance learning laboratories.

Engineering laboratories are essential because practical applications were the foundation of the engineering curriculum at its inception and the accreditation organizations are now attempting to restore this principle. There are 3 different types of laboratories: real, virtual, and remote. Real laboratories are the best for providing hands-on experience but are expensive; while virtual laboratories are much cheaper, they only provide ideal data from simulations which greatly reduces the experience gained by the student. Remote laboratories seem to be the middle ground by still utilizing real lab equipment by means of a network which reduces cost and allows for more flexible scheduling practices. Virtual and remote laboratories often take advantage of cloud technology because of its increased computing power and reduced cost and energy consumption.

The number of students enrolled in distance learning programs has been increasing for the last few decades and this trend will likely continue. As the need for distance learning programs escalates, institutions will be forced to develop these programs in order to stay competitive in the higher education market. Some programs require labs and thus remote or virtual laboratories will need to be created to avoid sacrificing the integrity of the course. As technology continues to progress the possibilities for remote and virtual laboratories is seemingly without bound.

Chapter 3: Technical Approach

In order to integrate cloud technology and digital measurement with a traditional hands-on laboratory, several techniques need to be exploited, including: 1) software development, 2) data acquisition, and 3) computer interface between physical mechanism and electronic devices. The course of Dynamics and Strength of Materials Laboratory in the department of Mechanical and Aerospace Engineering is currently in the stage of renovation and needs to be upgraded to a network connected environment. This research utilized the laboratory setups as a platform to implement the cloud-based remote laboratory environment.

3.1 Introduction to MAE 244

Students enrolling in the MAE 244 course are usually third or fourth year students and have already successfully completed Statics, Dynamics, and the first Mechanics of Materials course. According to Sierros and Liu [16], “the purpose of this course is to experimentally examine concepts developed in statics, dynamics, and strength of materials courses”. The students will have a chance to assess theories presented in the prerequisite courses, investigate the legitimacy of the conventions and observe the limitations of the theory [16]. The students are expected to attain hands-on experience from using the laboratory equipment as well as have their writing skills tested through the preparation of laboratory reports [16]. The learning outcomes expected are listed as follows [16]:

- An ability to apply knowledge of mathematics, science, and to analyze and interpret data;
- An ability to identify, formulate, and solve engineering problems;

- An ability to communicate effectively; and
- An ability to use the techniques, skill, and modern engineering tools necessary for engineering practice.

There are 8 labs total that the students must complete throughout the duration of the course. Each of the labs is related to a topic covered in one of the 3 prerequisite course: Statics (MAE 241), Dynamics (MAE 242), and Mechanics of Materials (MAE 243). Some samples of topics that will be covered include the following [16]:

- Mechanical properties and stress-strain curves of materials under tension, shear and tension, shear and torsion;
- Electrical resistance strain gages;
- Stress concentrations through fringe pattern analysis;
- Hardness, fatigue, and fracture of metals; and
- Vibration of components.

Although the lab topics are related, each lab is expected to offer a unique learning opportunity.

The list of the 8 labs and a brief description of the purpose of each is given below [16].

- Beam Bending – to gain an understanding of the relationship between an end load applied to a cantilever beams and the stress caused by load for different types of materials
- Tension Test – to gain an understanding of the relationship between stress and strain for different materials being subjected to a tensile force
- Impact Test – to gain an understanding of toughness, impact energy, and fracture mechanics for different materials at varying temperatures
- Photoelasticity – to gain an understanding of performing a stress analysis of materials with the use of fringe patterns

- Vibrations – to gain an understanding of the response of a single degree of freedom system under various values for the initial conditions: displacement and velocity
- Combined Loading – to gain an understanding of principal directions and stresses in a combined torsion and bending of a circular shaft fixed at one end
- Pressure Vessel – to gain an understanding of the strains and stresses experience by a pressure vessel given a certain internal pressure
- Hardness and Indentation – to gain an understanding of the hardness of materials by using an indentation method of testing

Upon completion of the Dynamics and Strength of Materials Laboratory, it is expected that the students have been able to apply the theory they have learned in previous courses in a practical manner and, thus, have attained a better understanding of the material.

3.2 Problem Statement

Currently, most of the experimental setups need to be operated and recorded manually. Before students can start to perform the lab procedure, calibration and initial processes need to be completed and without careful operations, the experimental results might not be accurate. Furthermore, the recorded result may be lost from time to time which requires students to redo the experiment under supervision. The purpose of this research is to design graphical user interfaces for selected experiments in an effort to lay the foundation of a remote, or networked, laboratory. Ultimately, the goal is to provide an environment in which authorized students can access the experiments anywhere that they have a network connection. There are two short term goals that this research focuses on with respect to the long term plans:

- Create graphical user interfaces that will allow students to collect data more efficiently; and
- Using an internet service, provide students access to their data anywhere that has an internet connection.

For this application, Google Drive will be the internet service used to provide access to data for students. The reason for this is that the MIX email service used by West Virginia University is powered by Google thus every WVU student also has access to Google Drive. Google also offers a social media service, known as Google Plus, which allows lab group members to connect and interact remotely.

The networked laboratory would require two sides working together: the students and the instructors/TAs/Graders. Both sides would need to fulfill their duties for the system to function properly; the system is explained below.

- 1) The instructor must initialize the directories for the data to be saved and grant students permission to directories by adjusting the sharing options in Google Drive
- 2) When the students perform the experiment using the interface a sub-directory will be created within the main directory setup by the instructor for the experimental data to be saved
- 3) Once the students have finished the experiment, their results will be available on Google Drive. After completion, the students must submit their laboratory report online so the instructor can grade it.

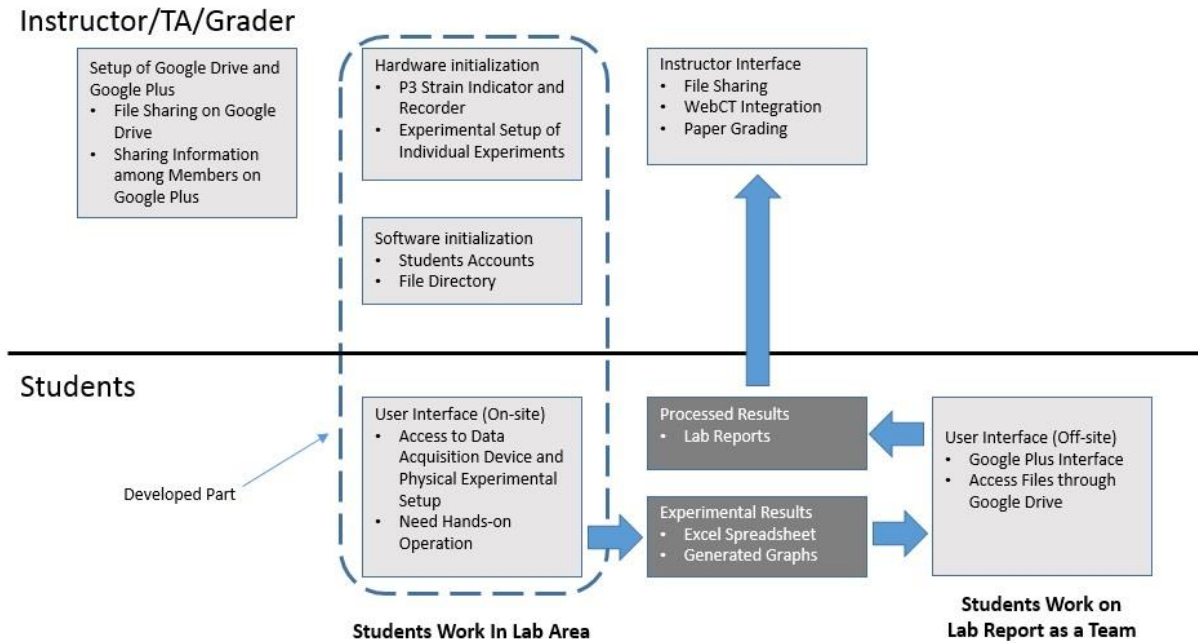

Figure 3-1: Diagram of Networked Laboratory

The part of this research currently being developed is identified in Figure 3-1 by the “rounded-dashed rectangle”. The current setup is capable of providing the following: 1) graphical user interfaces to be used by the students for data acquisition using the P3 Strain Indicator and Recorder, and 2) functions capable of saving the data onto Google Drive directly from the interface. Although the data can be saved directly from the user interface, the management of this data will still need to be done using the Google Drive interface at this time.

3.3 Setup of Hardware/Software

Of the 8 experiments in the Dynamics and Strength of Materials Laboratory, only labs that employed the P3 device were chosen since the P3 is necessary for the data acquisition component of the system described in the previous section. The reason this was the primary

concern was because this device had software that used ActiveX which would be used to connect the physical device to a developed graphical user interface. The 4 experiments that were chosen were: 1) Beam Bending, 2) Combined Loading, 3) Pressure Vessel, and 4) Tension Test. Each of these experiments and their respective interfaces will be described in their own section; however, there were some components that were used in all of the labs. As suggested previously, all of these experiments utilize the P3 Strain Indicator and Recorder, the other common element is the use of Microsoft Visual Studio 2010 to develop the interfaces. With the current software setup, the developed user interface can be ported to future versions of Windows as well as future versions of Microsoft Visual Studio.

3.3.1 P3 Strain Gage Indicator and Recorder Hardware/Software

The P3 Strain Indicator and Recorder, which is manufactured by Micro-Measurements, a division of Vishay Precision Group, Inc., has a hardware and a software component. The hardware portion includes the actual P3 Strain Indicator and Recorder and the USB cable (shown in Figure 3-2) used to connect the P3 to the computer running the interface. According to Micro-Measurements [17], “the Model P3 Strain Indicator and Recorder is a portable, battery powered precision instrument for use with resistive stain gages and strain-gage-based transducers”. The P3 device is capable of using full-bridge, half-bridge, and quarter-bridge inputs with resistances of 120-ohm, 350-ohm, or 1000-ohm [17]. Modern digital processing allows the P3 device to reject noise well and to be exceptionally stable while also providing unrivaled accuracy [17].



Figure 3-2: Model P3 Strain Gage Indicator and Recorder Hardware [<http://www.vishaypg.com/>]

The Model P3 is an intuitive device that can be controlled directly from the “front panel keypad” or remotely, via a USB connection and can save data to SD cards, MMC cards, or, when using the USB connection, directly onto the computer [17]. One complication that has been experienced when using the USB connection, which is required to provide data to the interface, is a dropped connection between the P3 device and the computer running the interface. When the connection is dropped the user must unplug the device and plug it back in. While this is not a difficult process, it can be an annoyance when trying to perform the experiment with the interface. There were attempts to determine the cause of this issue but, at this time, the exact cause is unknown (i.e. bad USB cable or software issue); there is hope that the new version of software provided by Vishay Precision Group will allow for better connections. To overcome the connection failure during the experiments, the program needs to check the connection while initializing the device.

One important aspect of the P3 device to consider is the sampling rate. The P3 device is capable of producing 480 samples per second with resolution of 24 bits (noise-free resolution: 18

bits typ.). Knowing the sampling rate is important in determining how frequently dynamic measurements can be updated. If the sampling rate was high enough, the system could be considered continuous, but, as it is, it would be categorized as a discrete system. Resolution is critical for the accuracy of the measurements so the higher the better.

The software being used for this research was developed for the P3 firmware, and although there is a more recent software version for the D4 firmware, it was developed after the research was almost complete and there was not time to incorporate the new firmware. The only real advantage that could be gained from the new firmware, other than the possibility of a better USB connection, is that it allows for 2 devices to be connected simultaneously. This will be discussed further in the Pressure Vessel section. The software's main purpose is to provide the user an easy-to-use interface to control the P3 device and record the values from the strain gages attached to the device. The interface is a display that mimics the look of the front panel of the P3 device as shown below. The interface provides a real look and feel for the user when the device is being controlled remotely; the "front panel" of the interface can be adjusted like the front panel of the actual device. The software also contains an ActiveX driver (.dll) that can be easily accessed by Visual Basic, which is the main reason Microsoft Visual Studio 2010 was used for the development of the interfaces for this research.

3.3.2 Microsoft Visual Studio 2010

The P3 device is capable of being accessed by several software platforms, such as Visual Basic, LabView, MATLAB, and C++ Builder, etc. Visual Basic was the language chosen to create the applications for this research. Along with having an easy-to-use Integrated

Development Environment (IDE), Microsoft Visual Studio (shown in Figure 3-4), Visual Basic also has the following benefits: Integration, Recyclability, and Compatibility. Visual Basic works well with ActiveX which is what powers the driver for the P3 device thus making it easy to integrate into the applications. Because the Model P3 Strain Indicator is represented as an object in the source code (shown in Appendix E), when newer versions of firmware are developed for the P3 device all that is required is to define a new object; the rest of the code can remain unchanged. Visual Basic is also designed to be backward compatible with previous versions. This means that the current source codes should be able to be used with newer versions of Visual Basic which will be needed for newer versions of Microsoft Windows as they are developed.

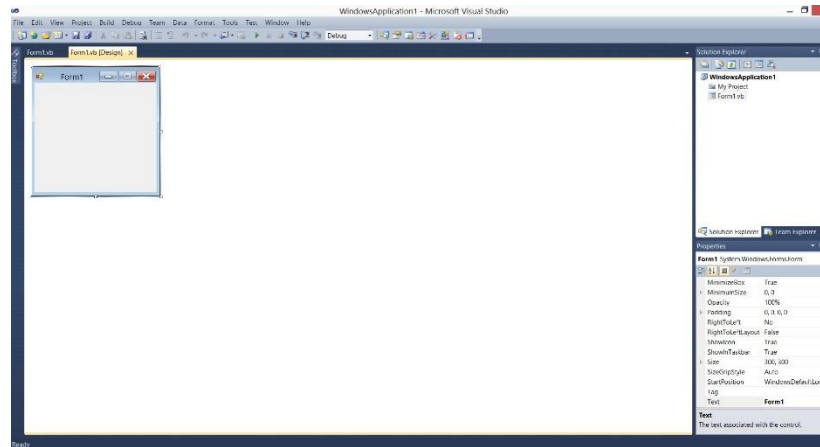

Figure 3-3: Visual Studio Workspace

Currently, the program is developed under Windows 7 using Visual Studio 2010. The code can be ported to Windows 8 platform with Visual Studio 2013 installed easily as long as the ActiveX object and the driver is supported by the operating system. The developed system has the advantage that it can be a “green” software if all the required software and libraries are

compiled into a single package. The “green” property makes it easy to switch platforms if upgrading the computer is necessary in the future.

3.3.3 Google Service

Other than the software required by a single PC, the software of cloud services provided by Google include: Google API and management of Google Drive and Google Plus. The functions of management are extremely important. Since the accessibility of directories need to be operated online, the management of the course relies heavily on the interface provided by Google. In addition, to prevent the experimental results or discussion viewed by other students, the instructor/teaching assistant must manage the pages carefully with the pages of the adopted Google services.

3.4 Application Overview

All of the applications developed for this research have some commonalities but they are all unique. The overall “thought process” of the interfaces is the same but each of them is designed specifically for one experiment. Due to the fact that they are experiment specific, they each have different requirements that need to be met in order to successfully acquire the necessary data. In order to make this happen, several different programming techniques had to be employed.

3.4.1 Integration of Hardware and Software

Simply stated, the main objective of this research is to combine hardware and software for data acquisition purposes to enhance the lab experience for the students in MAE 244. The set of hardware included in this process is comprised of the P3 Strain Indicator and Recorders, the strain gages, and all of the apparatuses required for each of the experiments. The software consists of the ActiveX drivers for the P3 device, Visual Basic, and Google services. The applications combine the hardware and software components into an easy-to-use interface for the lab. The purpose of the interfaces is to transfer the data from the P3 devices to a data format that can more easily be used by the students and be stored on the cloud via Google Drive. Figure 3-5 illustrates the integration of hardware and software.

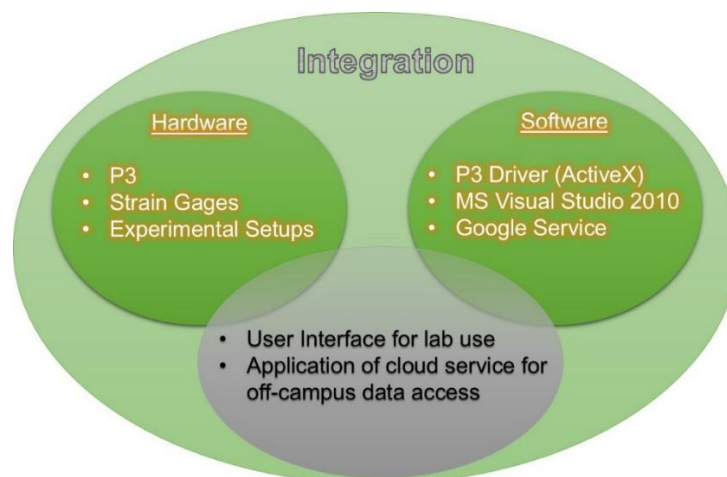

Figure 3-4: Integration of Hardware and Software

3.4.2 Thought Process of Interfaces

The interfaces all follow a similar progression from start to finish as shown in Figure 3-5. The main differences are what information is required to start the experiment but those will be discussed in the following section. After the interface is open, the initial parameters must be entered before continuing; these parameters will vary from experiment to experiment. The next thing the interface must do is ensure that the P3 device is properly connected via USB so that the P3 Object can be created in Visual Basic thus establishing the connection necessary to transfer data. If the P3 device cannot be detected by the computer then an exception will be thrown in the program and the interface will close and display an error message to notify the user what caused the interface to close. If the P3 is connected correctly then the program will begin according to which experiment is being done and Microsoft Excel will be open and remain running in the background but not visible to the user. As the experiment is being conducted the user inputs the data into the interface and then the interface sends that data to the corresponding cells in the Excel worksheet. Once the experiment is completed, the data will be saved to the location that has been pre-selected by the user. The recommended location is the Google Desktop folder so that the files can be uploaded automatically to Google Drive and then shared with each of the lab group members. If the lab needs to be repeated then the users must reopen the interface and proceed through the steps previously described.

3.4.3 Experiment Requirement Comparison

While all of the experiments were designed to operate in a similar fashion and use some common objects, there are several differences between how the objects are used. The main differences, in a general sense, are shown below in Table 3-1. The sampling rate is dependent on experimental procedure. For example, when performing the *Tension Test* a specimen is loaded in the machine and is elongated at a specified rate until failure. In this situation it is necessary to automatically record data at definite, constant time intervals because it would be considerably more difficult for a student to get accurate data by manually recording data. On the other hand, the remaining three experiments use various static load measurements so there is no need for constant sampling.

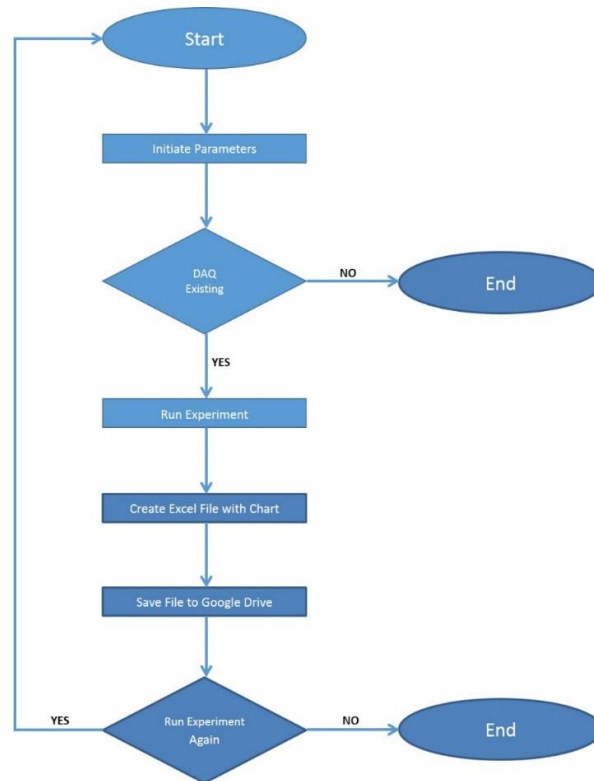

Figure 3-5: Flow Chart of the Program

The number of P3 channels needed for each experiment is dependent on the number of variables that need to be considered. The *Tension Test* only requires 2 channels because only the load and elongation are needed to calculate the stress-strain relationship which is the primary objective of that lab. The *Combined Loading* lab requires three P3 channels because there are three strain gages with different orientations at the section of interest. *Beam Bending* needs all four channels on the P3 device because it has two materials each with two strain gages to measure Axial and Transverse stress. The *Pressure Vessel* experiment requires eight P3 channels, which is the most of any of the labs, which, consequently, makes it the only lab that requires more than one P3 device.

Table 3-1: Requirement Comparison

Lab	Tension Test	Combined Loading	Beam Bending	Pressure Vessel
Constant Sampling	Yes	No	No	No
Channels	2	3	4	8
P3 Devices	1	1	1	2
Graphical Display	Yes	Yes	Yes	No

All of the interfaces include a graphical display of the data being recorded except for the *Pressure Vessel*. All of the readings from the P3 device are displayed in real time. The reason for not generating a graphical display is that the *Pressure Vessel* experiment has too much data being recorded at one time to have a meaningful comparison. The remaining experiments have at most three sets of data being recorded at once. The *Tension Test* compares the load versus the

elongation of the specimen which, in turn, compares the stress and strain experienced by the specimen. Observing the Stress-Strain relationship evolve in real-time is extremely beneficial to the students witnessing the procedure. The real-time display for *Beam Bending* shows the deflection versus the load which allows the students to obtain an understanding of the differences between the materials being tested. The three different strain gage orientations measured for the Combined Loading demonstrates how the strain can change simply by measuring from a different angle.

Although the P3 Strain Indicator and Recorders are used in slightly different capacities, the techniques used to access the P3 channel readings and transfer that data into Excel are the same. Each interface employs the P3 in the most efficient manner possible in order to obtain accurate data.

3.4.4 Programming Techniques

The interfaces developed for this research serves to transform the measurements obtained from the P3 devices into a more easy-to-use format; in this case, an Excel worksheet. The first step in this process is to create a connection between the P3 device and the computer. This is possible because the creators of the P3 devices utilize ActiveX for their dynamic-link libraries (dll). The dlls, also known as drivers, are paramount to being able to create and use a P3 object in Visual Basic. Provided that a connection is established between the P3 and the computer, a “P3 Object” can be created which can be called upon to return the current readings from a specified channel. Once the readings from the device can be obtained, the next step is to put them into a “better” format.

Microsoft Excel acts as an embedded object in this situation which is why having the drivers powered by ActiveX is necessary. Excel runs only in the background, not visible to the user, for the duration of the experiment. While it is open and the experiment is being conducted, data is pulled from the P3 device and placed in the corresponding cells in the Excel worksheet. When the interface is closed, the worksheet is saved in a pre-selected location for later access by the students. Being able to convert raw data into an Excel file is a huge benefit for the students because the students are used to using Excel and therefore more comfortable attempting to create a lab report from an Excel file rather than from raw data. Utilizing these techniques is really the keystone to this research; without it, none of this would be possible.

The code of individual programs are all based on the flow chart shown in Figure 3-5. The major modules of all of the programs are the functions of communicating with the P3 device and the functions of formatting the Excel sheet. The codes are all well commented for convenience. The source codes are located in Appendix E. These modules can be recycled if additional experimental setups require a new interface.

Google Drive allows the Excel files to be stored on the “cloud” and shared amongst the students within each lab group. These files are sent to Google Drive by selecting the Google Desktop Folder as the save location in the interface. Google Drive can be accessed from most electronic devices capable of connecting to the internet, including mobile devices. It makes it much easier and convenient for the students to access their lab results when writing the lab report. Drive is one of the state-of-the-art features included in this research and is a great benefit to the students.

3.4.5 Live Video Stream

In order to have an actual remote laboratory, a source of live video stream is necessary so that remote students can experience the lab by seeing the experiments being performed. There are several ways to setup a live video stream such as a web-based web cam or uploading live to YouTube but there are several drawbacks to this in an academic environment. The main issue with implementing a video feed at this time is WVU IT Policy. The live stream takes a tremendous amount of bandwidth. If all of the labs are operated simultaneously, the bandwidth available to upload may be insufficient. In addition, if the operation becomes automatic, the video stream will be activated periodically. Thus, the video stream will behave like a virus which may cause the IT Department to block the stream thus rendering the “live video stream” useless. There are also some stability issues associated with live streaming and both ends will have to have compatible operating systems for it to work properly. With all this in mind, creating a live video stream for the experiments is not feasible at this time.

3.5 Beam Bending

Beam bending is usually one of the first experiments that students get to experience in the MAE 244: Dynamics and Strength of Materials Laboratory. The purpose is to measure the deflection and strains of a cantilever beam subjected to various end loads. A schematic is shown in Figure 3-6.

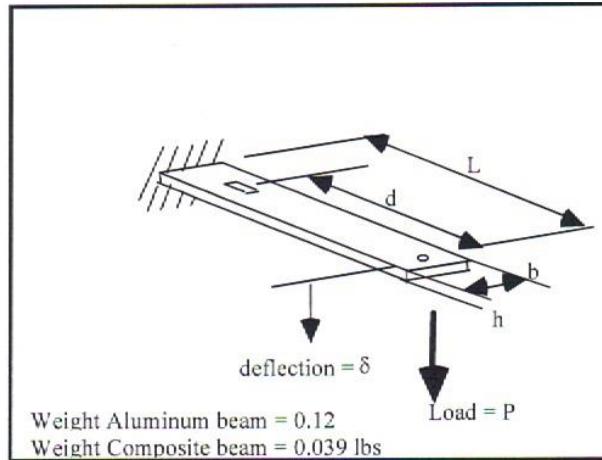

Figure 3-6: Schematic of Cantilever Beam for Beam Bending Experiment [16]

In the actual lab setup (Figure 3-7), there are two cantilever beams side by side with a vertical ruler between the two beams to measure the deflections. One beam is made of a composite material and the other one is made of aluminum; there are also some slight variations in the dimensions between the two. There are two electrical resistance strain gages attached to each beam; one is placed on the top to measure the longitudinal strain and the other on the bottom to measure the transverse strain. There are 5 loads that are applied in half pound increments starting at zero and ending at 2.5 pounds. After each load is applied the deflection, transverse strain, and longitudinal strain are measured and recorded. This is done for both beams.

After the experiment is completed, the students are expected to use the data obtained to do some calculations in order to satisfy the objectives of the experiment. The objectives listed in the Laboratory Manual are given below [16]:

- To obtain strain measurements at the surface of a cantilever beam using strain gages;

- To determine the Modulus of Elasticity (Young's Modulus) and the Poisson's Ratio of a material used in a cantilever beam, from strain measurements on the surface of the beam;
- To validate the measurements from strain gages by using elementary, linear beam theory to calculate the corresponding values of theoretical strain; and
- To assess the difference in elastic properties between fibrous composites and metals.

The results of these calculations and objectives should then be discussed in the Laboratory Report and the student's understanding of the subject matter is evaluated based on the quality of the report.

3.5.1 Equipment

The equipment for a laboratory experiment is essentially the experiment itself because without the equipment, the experiment cannot be done.

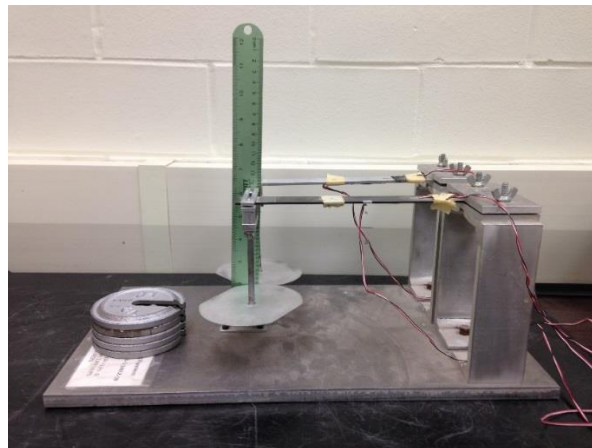

Figure 3-7: Beam Bending Experimental Setup

Some of the equipment use for *Beam Bending* has already been mentioned in the previous section but will be repeated in order to obtain a complete, comprehensive list. The following is the list of necessary equipment for the traditional *Beam Bending* experiment: 1 Composite Beam, 1 Aluminum Beam, Ruler, Base to fix beams and ruler to, 5 – 0.5 pound weights, 4 Electrical Resistance Strain Gages, P3 Strain Indicator and Recorder, and wires to connect the strain gages to the P3 device. The equipment list for the experiment using the interfaces includes all of the equipment from the traditional method as well as some additional pieces. The additional equipment is: USB cable to connect the P3 to the computer, computer itself, and the interface. The interface is obviously the main difference and is the chief focus in this research; the development of the interface is explained in the next section.

3.5.2 Interface Development

The *Beam Bending* interface (shown in Figure 3-8) was designed to be user-friendly and each component has a specific purpose; panels were used to group similar elements. The “Group Information” panel contains two text boxes that the user must input his or her course section and group number in order to generate a folder to save the data. The “Calibration” panel are apparatus parameters, gage factor and gage resistance, that are given to the students. The “Dimensions” panel contains 8 text boxes, 4 for each beam; the students must take measurements of the required parameters and supply them to the interface. The “Channel Select” panel allows the user to select the P3 channel that corresponds to the appropriate strain. The bottom left panel allows the user to select a location, within the computer, to save the results and also displays the chosen location. The bottom right panel is the control panel; all the buttons

are located in this panel along with the progress bar. The “Start” button initializes everything, the “Save” button saves the data for the current load, the “End” button checks that everything has been closed correctly and then closes the interface, and the progress bar has a maximum of 10, 5 for each material, and serves to track the progress of the experiment. The panel above the control panel is used to select the applied load from a drop-down menu and to input the measured deflection for each load. The panel below the graph on the right is used to display the strain readings from the P3 device and for the user to select which beam is having the loads applied at the current time. The graph’s purpose is to visually display the deflection of the beams in real-time in order to provide the user a graphical representation of what is happening.

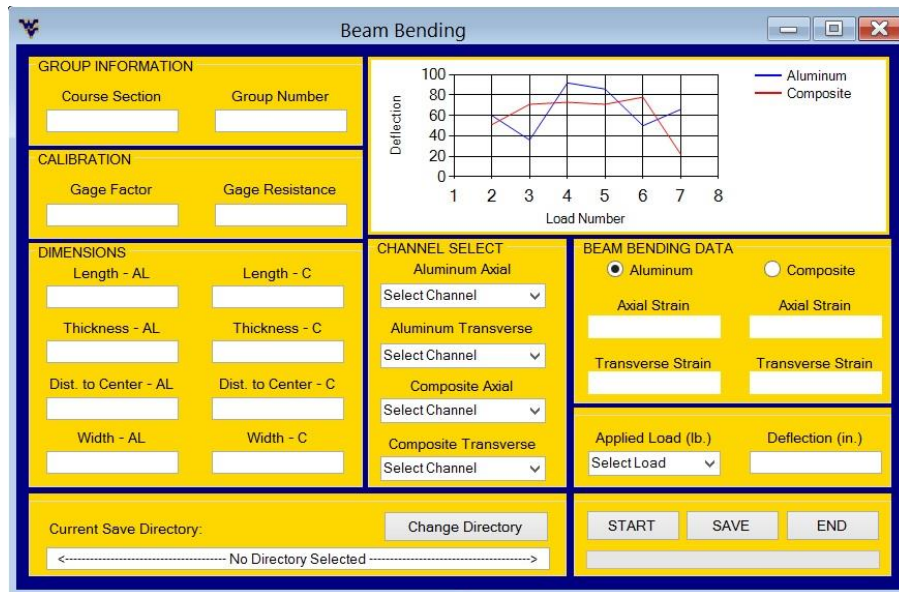

Figure 3-8: Beam Bending Interface

The purpose of the *Beam Bending* interface, as with all the other interfaces, is to provide a more efficient data acquisition experience for the students of the MAE 244 Laboratory. The order of operations of the interface is described by the following sentences. Upon opening the

interface, if it is the first time the interface has been run on that computer, the user will be prompted to select a save directory for the subsequent data; if the interface has been opened previously, the directory that was previously selected will be displayed but the user may change this directory if desired. The next thing the user should do is to input the course section and group number; this creates a folder in the directory to save data if a folder for that Section and Group does not already exist. The next step is for the user to input the parameters of the experiment. Two of the parameters, gage factor and gage resistance, are given to the students but the remaining 8 parameters are based on the beams and must be measured by the students before entering into the text boxes. The last step before actually conducting the experiment is to select the channels that correspond to the appropriate strains by using the drop-down menus in the “Channel Select” panel. At this stage, the user should click the “Start” button. When the “Start” button is clicked Excel is opened in the background, but not visible to the user, and a spreadsheet is created; the information that has already been entered into the interface is placed into the appropriate cells, and the initial position of the Aluminum cantilever on the ruler is entered into a pop-up input box. The students can now proceed with the experiment.

While one student operates the interface, the rest of the group should participate in applying the weights and reading the new positions of the Aluminum beam on the ruler. As the weights are added to the beam and the new positions are determined, the user should select the corresponding Applied Load from the drop-down menu, enter the new position of the beam, and click “Save”. This will save the deflection value and strains from the P3 device associated with that particular load to the appropriate cells in the Excel spreadsheet; the graph will also be updated with the addition of the most recent deflection. This process is repeated for the remaining 4 loads that will be applied to the beam. Upon clicking “Save” for the 2.5 pound

applied load for the Aluminum beam, another input box pops-up for the user to enter the initial position of the Composite beam. The radio button linked to the Composite beam should then be pressed and the process is repeated for all 5 applied loads. After all the loads for each material have been completed such that the progress bar reaches its maximum, the Excel spreadsheet is formatted and saved to the pre-selected directory. At this point, the user can click the “End” button which will ensure that Excel has been closed properly then close the interface itself and the experiment is completed.

3.5.3 Laboratory Procedure Comparison

The lab procedure starts the same with the exception of having to open the interface on the computer. The first step for both methods is to determine and record the parameters of the experimental setup. The difference is how the parameters are recorded; the traditional method requires students to write on paper whereas the interfaces allow the students just to type into the appropriate text boxes. Using the interface does require an extra step because the user has to select which channels are being used for which strain but this saves time in the long run. In the traditional process the students must read the values of the strains from the P3 device after each load is applied and fill in the table shown in Table 3-2; with the interface, after the channels have been selected the interface will automatically record the values from the P3 device into the Excel spreadsheet. The weights are applied in the same manner in both methods and the deflections are measured in the same way. One difference in recording the deflections is that, in the traditional method, the student must calculate the deflection by comparing the new position with respect to the reference position at zero load; but, when using the interface, the student only

needs to enter the new position and the interface will calculate the deflection by comparing it to the reference position entered into the pop-up input boxes.

Table 3-2: Chart for Beam Bending Data Recording [16]

Dimensions of Aluminum Beam: Length, L, Thickness, h Free End to Gage Center, d Width, b			
Applied Loading (Lbs)	Aluminum Axial Gage (μ t)	Aluminum Transverse Gage (μ t)	Beam-Tip Deflection (in)-Alum.
0			
0.5			
1.0			
1.5			
2.0			
2.5			

Dimensions of Composite Beam: Length, L, Thickness, h Free end to gage center, d, Width, b			
Applied Loading (Lbs)	Composite Axial Gage (μ t)	Composite Transverse Gage (μ t)	Beam-tip Deflection (in)-Comp.
0			
0.5			
1.0			
1.5			
2.0			

One thing the traditional method does not have is a graphical representation of what is happening in real-time. The graph provided in the interface allows the students to “watch” how the applied loads affect the deflection of the beams. This may improve the understanding of the *Beam Bending* experiment for some students rather than only have a chart of numbers to look at; the impact of the graph will be examined in Chapter 4. It can be seen that while there are several differences in the procedure when the interface is implemented, the majority of these differences involve how the data is recorded and consequently the format in which the students receive the data.

3.5.4 Summary

Performing the *Beam Bending* lab using the developed interface is not drastically different other than how the data is recorded and shared. The traditional method requires students to fill in a chart provided by the lab manual as shown Table 3-2 as compared to entering the information into the interface. The developed interface still captures all of the necessary parameters and data but the students do not have to write anything. Also, with the traditional method, one student in the group is usually responsible for entering the data into the chart from Table 3-2 and then after the lab is over the remaining group members copy the data onto their tables. Each student must then import the data into Excel in order to complete the laboratory report. Using the interface, all of the students can participate in the experiment and still receive the same data, without the possibility of incorrectly copying data or forgetting some of the data or parameters and it will already be in an Excel format. This can be a big time saver when it comes to writing the laboratory report because the data is in a more usable and easy to understand form.

The other significant difference is the student's accessibility to the data outside of the lab when using the interface. When performing the experiment by way of traditional means they only have the data on a piece of paper or, if they have already entered the data into Excel, on a flash drive. While this is not necessarily a problem, it can be if the piece of paper or flash drive is lost or forgotten. The interface is designed to incorporate a cloud storage system that will allow the student to access their results anywhere they have an internet connection. The cloud is utilized by selecting the appropriate location to save the data that will automatically sync with the storage system; details of this cloud storage system will be discuss in Section 3.9. This means that students can work on their report almost anywhere even if they had not planned on doing so. This will help students write their report because if they got an unexpected break from

classes they can spend that time working on their report even if they did not bring their flash drive or raw data sheet.

3.6 Combined Loading

Combined loading is one of the more advanced topics covered in the Dynamics and Strength of Materials Laboratory because it is a combination of several other, simpler concepts. The purpose of the *Combined Loading* lab is to help reinforce the concept of Plane Stress and Stress Transformation. A top view schematic of the experimental setup is presented in Figure 3-9. As shown in the schematic, the apparatus used for this lab is a circular beam fixed at one end and a more rectangular beam attached to the opposite end forming an “L” when viewed from above. At the fixed end of the circular beam there are 3 electrical resistance strain gages placed at 3 different angles with respect to a line normal to that of the longitudinal center line of the main beam. The 3 strain gages are placed at 0° , 45° , and 90° and form a “rosette”. Loads are applied using the *Tension Test* machine that will be discussed in Section 3.8. The number of loads varies depending on how many the instructor wishes to have but usually is between 4 and 8 with 100 pound increments; as the loads are applied, the strains are recorded via the P3 Strain Indicator and Recorder.

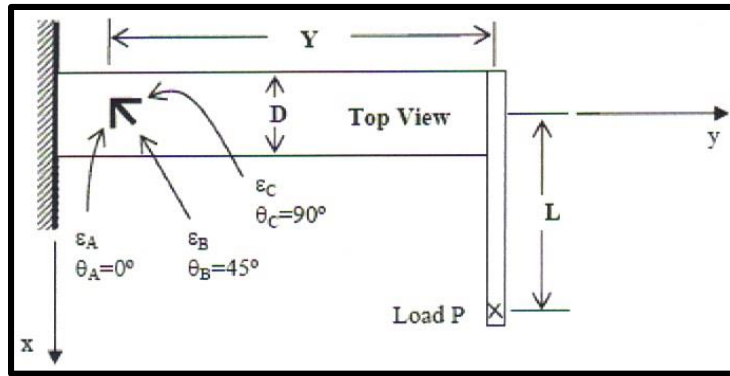

Figure 3-9: Combined Loading Top-View Schematic [16]

The students are expected to “determine the principal directions and principal strains and stresses at the location of the rosette” [16]. Students are also required to construct a Mohr’s Circle of strain and calculate some additional stresses.

Based on the setup and procedure described above, this lab strives to fulfill the following objectives [16]:

- Use “Wheatstone Bridge” circuits to measure the resistance change of a strain gage due to an applied load
- Use strain rosettes for determining principal directions and stresses in a combined torsion and bending of a circular shaft clamped at one end
- Related data and/or modeling analyses

The students understanding of the above objectives is decided by the quality of the discussion provided in the laboratory report that each student is required to submit following the completion of each lab.

3.6.1 Equipment

The traditional method for the Combined Loading lab does not require a lot of equipment but the main piece is a combination of smaller pieces. The list of equipment is: 3 Electrical Resistance Strain Gages, a Combined Loading “arm”, and a P3 Strain Indicator and Recorder.



Figure 3-10: Combined Loading Experimental Setup

The combined loading arm is a composite of 3 smaller pieces. The main component is a circular beam on which the strain gages are located. This circular beam is welded at one end to a base that creates stability for the apparatus. On the opposite end of the circular beam, a more rectangular beam is welded to create an “L” shape. This last piece is necessary to create a combined loading scenario. When using the developed interface, there are a few additional parts that are needed to complete the experiment; they are as follows: a USB cable to connect the P3 to the computer, the computer itself, and the interface. This lab is relatively simple as far as the procedure is concerned but the developed interface does have some advantages as will be seen in the following sections.

3.6.2 Interface Development

Similar to *Beam Bending*, the *Combined Loading* interface (shown in Figure 3-11) was designed to be simple and easy to use. The panels were used to group similar information to provide organization on the screen. The “Group Information” panel is used to attain the user’s course section and group number so that the interface can create a directory in which to save the results obtained from the experiment. The “Calibration” section is for two parameters that are given to the students, gage factor and gage resistance. The necessary measurements of the “arm” are entered in the “Dimensions” panel. The “Channel Select” panel is used to select which channels on the P3 Strain Indicator and Recorder are connected to corresponding strain gages. The bottom right panel is used to select the location that the data will be saved. The “Combined Loading Data” sections serve several purposes. This panel contains the buttons that control the interface, the labels that display the readings from the P3 device, a text box that is used to input the current applied load, and a progress bar. The progress bar is used to track the progress of the experiment so that the interface will know when all the loads have been applied. The graph in the top right corner is in place to provide the students a graphical representation of not only the relationship between each strain and the applied load, but also to compare the strains to each other in real time.

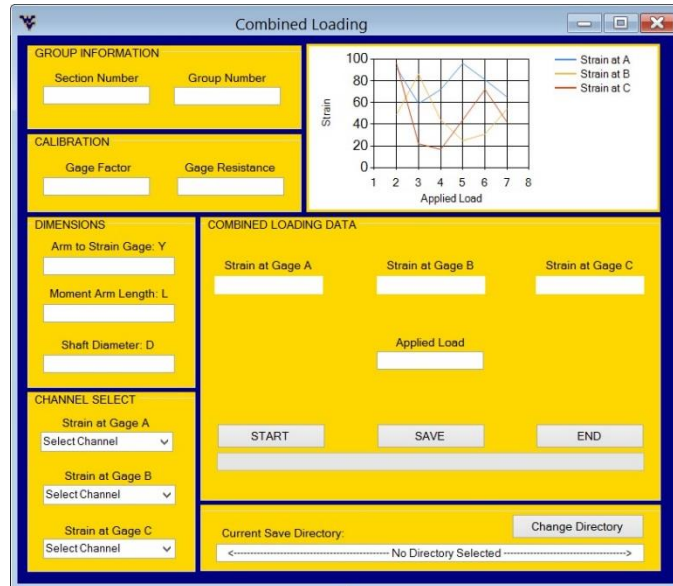

Figure 3-11: Combined Loading Interface

This interface was created for the purpose of improving the data acquisition process of the *Combined Loading* lab. The first thing the user needs to do is open the interface; if this is the interface's first time running on the machine being used, the user will be prompted to select a save directory, if it has been opened before then the interface will use the previously selected save location to store the results. Secondly, the user needs to enter his or her course section and group number so a sub-directory can be created in the main save directory if one does not already exist. Thirdly, the user should measure and enter the requested parameters in the "Calibration" and "Dimensions" panels. The fourth thing that needs to be done is channel selection. The students must trace the wires from the strain gages on the apparatus to the P3 device and select the appropriate channel for each strain from the drop-down menus.

At this point the "Start" button can be clicked. When this happens, Microsoft Excel is opened, but remains invisible to the user, a spreadsheet is created, the information that has been entered thus far is entered into the proper cells, and an input box pops up requesting the number of

loads that will be applied. The number of applied loads is crucial for the automation of the saving operation. The number of applied loads entered into the input box becomes the max value of the progress bar and it starts at zero. The students now apply the first load to the apparatus, enter the load amount in the corresponding text box, and the labels display the strain readings from the P3. Next, the user should click “Save” so that the strain readings and load amount are entered into the Excel spreadsheet and the progress bar value is increased by one. The interface will continue to accept loads and read the strains until the progress bar has reach the maximum number of applied loads. When the progress bar becomes full, the spreadsheet will format itself, save to the pre-selected location, and close Excel. The user should now click “End” which will save the data to the preselected location, close Excel, and then close the interface itself, signaling the completion of the lab.

3.6.3 Lab Procedure Comparison

The lab procedure between the two different methods will mainly vary in the data recording aspect. The students must still measure the distances, Y, L, D, as shown in Figure 3-9; where Y is the distance from the arm to strain gage, L is the moment arm length, and D is the shaft diameter. The difference in this step is that while the traditional way requires students to write, the interface allows students to type. The fact that students have to select which channels are displaying which strains is an extra step in the interface method but it does save time during data recording. Usually, the students would have to fill in the table displayed in Table 3-3 with the applied loads and then each of the 3 strains being measured.

Table 3-3: Chart for Combined Loading Data Recording [16]

Applied Load (LBs)	Strain at Gage A $\mu\epsilon$ ($\theta_A = 0^\circ$) Channel #1	Strain at Gage B $\mu\epsilon$ ($\theta_B = 45^\circ$) Channel #2	Strain at Gage C $\mu\epsilon$ ($\theta_C = 90^\circ$) Channel #3

With the interface, after the channels have been selected, the students only have to type the applied load and the interface will record the strains automatically when the “Save” button is clicked.

The traditional *Combined Loading* lab does not provide any graphical representation of what is happening throughout the experiment. The graph is advantageous to the students because they can “see” what is happening. The lines generated by the strains provide the students an opportunity to visualize how the loads are influencing strain at each strain gage position. This is beneficial because it can capture the students’ attention and improve understanding more so than just filling in a chart with numbers that have no relevance at the time. Additionally, it’s usually only one or two group members recording the strains during the experiment and then the remaining group members copy the data. Using the interface permits the students to be engaged in the process and they all will received the same data but in a more easy to use format since in the traditional method they would have to import their written data into Excel anyway.

3.6.4 Summary

The interface may not save a tremendous amount of time during the actual performance of the experiment but it does have its advantages. Some of these have already been mentioned but a couple of the main ones have not. As previously stated, the interface allows the students to focus on what is happening in the experiment because they do not have to worry about recording the data and it also creates an opportunity for greater understanding as a result of the graph. Because the data is automatically placed in Excel, students do not have to be concerned with copying incorrectly or forgetting any necessary information. The fact that the data is already in an Excel spreadsheet will save time when the students are writing the report because that is the first thing they will have to do while using the traditional method.

The other advantage, other than how the data is stored and formatted, is the accessibility of the data outside of the laboratory. With the traditional method, the students will either have the data chart written in pencil or pen or they will have a flash drive with the Excel spreadsheet. The interface is designed to be able to save the data in any location on the computer so that it can utilize a cloud storage system and then a social network. This will allow the students to access their data anywhere they have an internet connection and also allow them to collaborate remotely. The details of the cloud storage and social media will be discussed in Section 3.9.

3.7 Pressure Vessel

The *Pressure Vessel* lab is one of the least time involved experiments although it deals with a topic that students will be exposed to in several other courses throughout their college

career. The purpose of this lab is to examine how the stresses and strains on a closed-ended cylinder are impacted by various internal pressures. A schematic of the lab setup, viewed from above, is shown in Figure 3-12. As shown in the schematic, the closed-ended cylinder, or pressure vessel, is connected to an air-line that allows the pressure in the tank to be adjusted. Attached to the cylinder are strain gages set at different orientations to gather the strains in different directions that will be used later to calculate the stresses on the tank at each load. As seen in the figure below, the gages are set at the following angles with respect to the longitudinal center line of the tank: 90° , 67.5° , 45° , 0° , -22.5° , -45° . According to the Laboratory Manual [16], the pressure is adjusted in increments of 20 psi with the maximum pressure being 80 psi.

One of the main differences between the *Pressure Vessel* and the other experiments that involve the use of a P3 Strain Indicator and Recorder, is that it requires two P3 devices. This is necessary because of the need for 8 strain gages to be used simultaneously and the fact that each P3 device only has 4 available channels. On completion of the lab, students are expected to do a write-up on their experience as well as their understanding of the concepts involved in this experiment.

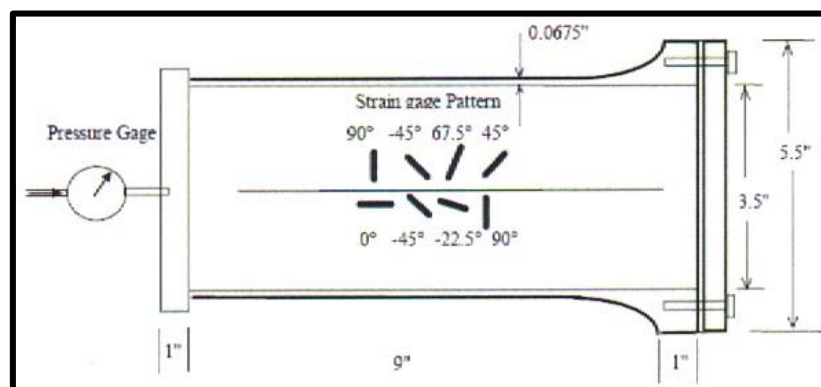

Figure 3-12: Pressure Vessel Schematic

The students are evaluated on their ability to meet the following objectives [16]:

- Experimental stress/strain analysis of a thin-walled cylinder under a state of uniform internal pressure, by employing any of two different approaches:
- Two-Dimensional strain transformation equations for analytical strain analysis, by using a uniaxial tension specimen
- Mohr's circle for graphical analysis of the biaxial state of stress at certain points on the wall of the pressure vessel

The students' ability to satisfy these objectives leads to the assumption that the students will have improved their understanding of the concepts presented.

3.7.1 Equipment

As seen in the previous section, the lab setup is fairly simple and only requires a few pieces of equipment.

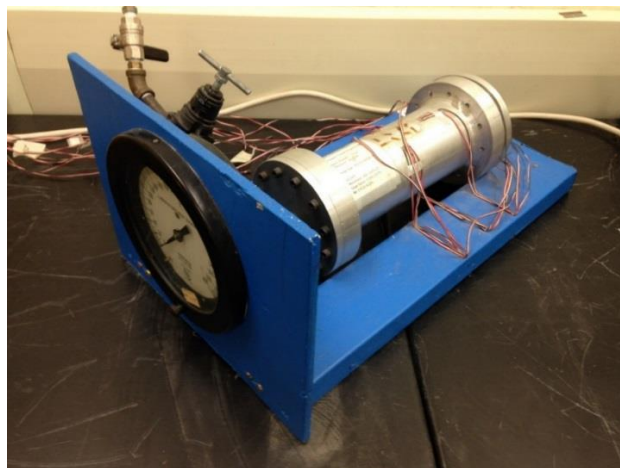

Figure 3-13: Pressure Vessel Experimental Setup

The following list is all the equipment required for the traditional method of the *Pressure Vessel* experiment: closed-ended cylinder (pressure vessel), an air hose, a pressure gage, 8 electrical resistance strain gages, 2 P3 Strain Gage Indicator and Recorders. In the more modernized method involving the developed interface, which will be described in the subsequent section, the same equipment is used along with the following additions: a USB cable to connect the P3 to the computer, a computer, and the developed interface. The integration of the interfaces is intended to improve the data acquisition process for the students with the hope that, in turn, they will gain a better understanding of the topics previously described.

3.7.2 Interface Development

The *Pressure Vessel* interface (shown in Figure 3-14) is straight-forward and the simplest design of the 4 interfaces. As with the previous two interfaces that have been discussed, sections were created to group common elements for organization purposes. The “Group Information” panel is used to collect the user’s course section and group number. This information will be used later to generate a folder to save data. The “Box 1 Strain Gage Orientation” and “Box 2 Strain Gage Orientation” are present for the students to input the orientation of each strain gage with respect to P3 channels of each device. As mentioned above, there are two P3 devices used in this experiment so “Box 1” and “Box 2” are used to differentiate between the two. The panel at the bottom right is used to select a place in the computer to save the data resulting from the experiment. The largest panel, located in the top right, is used to display the current strain readings from the P3 devices as well as to input the current pressure inside the tank. This large panel is also used to control the interface as the “Start”, “Save”, and “End” buttons are located

here along with a progress bar. The purpose of the progress bar is track the progress of the experiment and has a maximum value of 4; this means that 4 pressures will be applied to the cylinder throughout the experiment.

When using the interface to conduct the *Pressure Vessel* laboratory, the first step is to open the interface on the computer and make sure the USB is properly connected to the P3 device. If it is the first time the interface has been opened on the computer being used, the user will be prompted to select a save directly in which to save the data not only for this lab but any other labs that the computer will be used for. If a save directory location has been selected in a previous session, that location will be displayed in the text box but the user still has the option to choose a different location if desired. The next step is to input the course section and group number of the user so that when the “Start” button is clicked a sub directory will be created within the main save directory so the data from each group can be kept separated from one another.

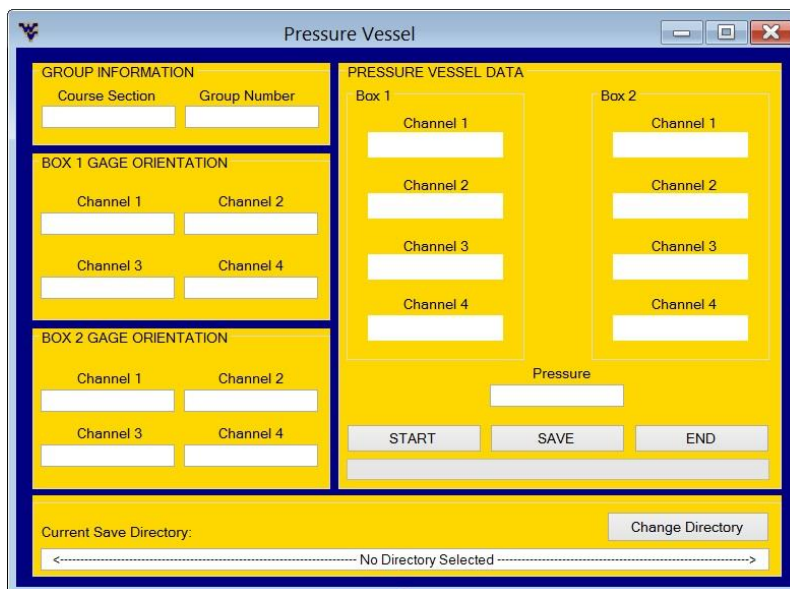

Figure 3-14: Pressure Vessel Interface

The ensuing step is to determine which strain gages are connected to which channels on the P3 devices and enter the orientation of each gage into the appropriate text box in the interface. After entering all of the information just stated, the user should click the “Start” button. When this happens, Microsoft Excel will open but be invisible to the user, a spreadsheet will be created and the information that has already been entered will be placed into the spreadsheet. The remaining process is conducting the actual experiment which involves adding internal pressure to the tank, entering that value in the text box titled “Pressure”, and clicking “Save”. When the “Save” button is clicked the current readings from the P3 device, which are displayed in labels in the “Pressure Vessel Data” panel, are placed into the Excel spreadsheet and the progress bar value is increased by 1. The next pressure is supplied to the tank and the process is repeated. This is done until all of the pressures have been applied and the value of the progress bar is equal to its maximum value. When the progress bar is maxed out the Excel spreadsheet will be formatted and the user will be notified that the experiment has been completed. The final step for the student is to click “End” which save the Excel file and close Excel and the interface itself, officially concluding the experiment.

3.7.3 Lab Procedure Comparison

Starting the experiment requires a bit more time when using the interface because some extra information is necessary. When using the non-traditional method, the interface must first be opened and the course section and group number must be entered before you get to the starting point of the traditional method. At this point, the students must determine which

channels are associated with which strain gage. There really is not much difference here other than that with the traditional method the students have use a pencil to fill in a chart similar to Table 3-4 and when using the interface they have to input the orientation of each strain gage in the correct channel text box. The internal pressure is applied and regulated the same way for both methods which leaves only the recording of the strains. How the strains are recorded is the main difference between the traditional and non-traditional methods. In the traditional process, the students must read each channel of the P3 after each pressure is applied and place the value of the strain in the corresponding box in a chart similar to that of Table 3-4. Since the interface is connected to the P3, it can record the values of the strains produced by the pressure and put them into the Excel spreadsheet automatically. This allows the students to stay more engaged throughout the experiment and saves time.

Table 3-4: Chart for Pressure Vessel Data Recording [16]

	Gauge 0°	Gauge -45°	Gauge 67.5°	Gauge 45°	Gauge 90°
Channel number					
Pressure (psi)	Strain ($\mu\epsilon$)	Strain ($\mu\epsilon$)	Strain ($\mu\epsilon$)	Strain ($\mu\epsilon$)	Strain ($\mu\epsilon$)
0					
20					
40					
60					
80					

Another big difference is how the students transport and share the data. With the traditional method, the students only have the charts that they have filled out or, if they decided

to enter it into Excel after the lab, they have it saved on a computer or on a portable memory device. Generally, during the experiment, only a couple students at most are filling in the chart and then at the end the remaining students in the group copy the data. As long as the students do not forget to record any pertinent data and copy correctly there are no issues, but the possibility of a student getting incorrect or incomplete data is present.

With the paper chart or data saved on an electronic device, the students only have accessibility when they have the paper or device. This means that if the student forgets their data on in these formats then they are just “out of luck”. Utilizing a cloud storage service to improve the ability of the students to access their data. The details of this cloud storage will be discussed in Section 3.9, as well as the integration of social media; but, ultimately, the cloud gives the students access anywhere they have an internet connection.

3.7.4 Summary

The *Pressure Vessel* lab is expected to test and improve the students’ understanding of stresses and strains associated with a closed-ended cylinder with an internal pressure. The students are expected to use the lab equipment and follow the procedure outlined in the laboratory manual to satisfy the learning objectives that were stated earlier. The interface was developed to enhance the learning experience for the students by allowing them to focus on the experiment being conducted rather than on recording the data. There are a few differences between the traditional method and the one that uses the interface but the main difference is how the data is recorded and the accessibility to the data outside of the lab.

3.8 Tension Test

The *Tension Test* is probably one of the most fun labs for the students because it involves breaking things. The purpose of this lab is to gain an understanding of the relationship between stress and strain and the difference between brittle and ductile materials, deformation of a specimen subjected to tensile loads, and determining elastic material constants. A schematic of the *Tension Test* is shown in Figure 3-15. The procedure for this experiment is simple but takes some time because the load must be applied gradually to demonstrate the material properties that are of interest. There are two materials used in this lab: Aluminum and Plexiglas. The Aluminum is used to show the effects of stress and strain on ductile materials while Plexiglas is used to show those effects on brittle materials.

To begin the experiment, the students must set up the computer software for the *Tension Test* machine, measure the dimensions of the specimen, and clamp it in to the testing machine. Once the rate at which the load will be increased is set and the extensometer is attached, the experiment begins to pull axially on the specimen. The axial loading will continue until the specimen breaks. This process will be repeated for the remaining specimens of which there are a total of 6; 3 of each material. The machine applying the axial force measures the load while the extensometer measures the elongation of the specimen. The load and elongation are used to calculate the stress and strain, respectively, using the dimensions of the specimen prior to testing. The students receive the load and elongation data in an ASCII format that can contain hundreds or thousands of points; the students then have to import this data into Excel before it can be used.

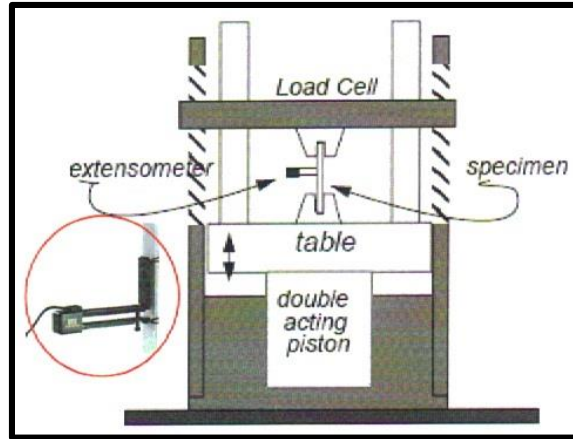

Figure 3-15: Tension Test Schematic

The objectives that the students are expected to achieve by conducting this lab are given below [16].

- To learn the operation of modern tensile testing equipment
- To conduct tensile tests on ductile and brittle materials, Aluminum and Plexiglas

After completing the lab, the students are required to write a laboratory report and they are expected to showcase their knowledge and understanding on the subject matter in this report.

3.8.1 Equipment

The *Tension Test* requires only a few pieces of equipment but is one of the most expensive labs because of the *Shimadzu* machine shown in Figure 3-16. The total list of equipment required to conduct the traditional *Tension Test* is as follows: Shimadzu machine, Aluminum specimens, and Plexiglas specimens. This particular tensile testing machine is capable of calculating the elongation without the use of an extensometer by measuring the distance that the cross-member (the piece below “Load Cell” in Figure 3-15) moves; however, in

general, an extensometer is used because it is more precise. When using the interface to perform this experiment it is necessary to have an extensometer that can be connected to a P3 Strain Indicator and Recorder and a load cell that allows the machine to also be connected to the P3 device.



Figure 3-16: Tension Test Experimental Setup

The additional equipment necessary for this experiment, other than what has already been listed, includes: a USB cable to connect the P3 to the computer, the computer itself, the interface, an extensometer, a P3 Strain Indicator and Recorder, and load cell capable of connecting to the machine and P3. The extra equipment and use of the developed interface is intended to improve the students' experience as well as provide more accurate data in a more student-friendly format.

3.8.2 Interface Development

As with the other 3 interfaces developed for this research, the *Tension Test* interface was intended to be simple and easy to use. Again, this interface is comprised of panels of common elements for the purpose of organization.



Figure 3-17: *Tension Test Interface*

The “Group Information” section is used to collect the course section and group number of the user to create a folder within the main save directory at a later time. The “Specimen” panel is used to record the specimen material and the specimen number so that the data can be matched accordingly. The “Parameters” section is used to select which units are being used as well as the initial dimensions of the specimen including length, thickness, and width; data rate is also required to determine the rate at which data points will be saved. The “Output” panel is for selecting the channels that are associated with the equipment measuring the load and elongation in addition to displaying the load, elongation, stress, and strain. The bottom right panel is used to select the save directory location within the computer for the data that results from the

experiment. The chart area is used to display a stress-strain graph in real time. There are also some control buttons placed throughout the interface.

To start the experiment, the interface first needs to be opened. If it is the first time running on that computer, the user will be prompted to select a save directory location in which to save the data; if it's not the first time, the previously used location will be displayed in the text box but the user will still have the option to change it. Second, the user should enter his or her course section and group number so that when the "Start" button is clicked a folder, with that section and group, will be created to save the experimental results. Third, the user should select the material of the specimen from the drop-down menu and enter the specimen number. Fourth, the students need to measure the width, thickness, and length of the specimen and enter those values into the appropriate text boxes as well as the desired data rate. Fifth, the specimen needs to be clamped into the *Shimadzu* machine and have the extensometer attached properly to read the elongation.

The last step before starting the experiment is to select the channels of the P3 that are connected to the device measuring the load being applied and the extensometer so that the values of the load and elongation, as well as the stress and strain, can be displayed throughout the test. The user is now ready for the gradual loading to commence; to make this happen, the user will have to coordinate the start of the main machine with the interface because the controls of the two are not connected. Finally, when the user clicks the "Start" button, Excel will open in the background, create a spreadsheet that will contain the information that has already been entered into the interface, and the readings from the P3 device will begin to be displayed, save to the spreadsheet, and plotted. This will continue until the specimen has been broken.

When the specimen breaks, the interface will stop recording and the Excel spreadsheet will be formatted and saved automatically to the folder generated based on the course section and group number. The test is finished for that specimen but the lab is not finished because there are 5 more specimens that need to be tested. At this point, the user can click “Clear” to clear the chart area in preparation for the next specimen or close the program if no more tests are to be conducted. The Excel spreadsheet will be available to the students in the location that was chosen in the beginning of the experiment. They can transfer the data to a jump drive if the save location was not chosen to utilize a cloud storage service that is in place.

3.8.3 Laboratory Procedure Comparison

The laboratory procedure for this experiment is short and simple so there are not many differences between the traditional method and the non-traditional method. The method employing the interface has a few extra steps prior to the measuring the specimens which is the first step for the traditional method. With the interface the students must open the interface, enter their Course Section and Group Number, and select their material and enter their specimen number before they input the parameters of the specimen. Measuring the specimen is the same in both methods but recording the measurements is slightly different. In the traditional method, the students use the chart shown in Table 3-5 compared to just entering the values into the interface and thus into Excel.

Table 3-5: Chart for Tension Test Data Recording [16]

(Estimate Values from Computer for comparison only)							
Specimen	width	thickness	Yield Stress (ksi)	Peak Stress (ksi)	Max % Strain (% in/in)	Modulus (Msi)	Toughness (lb/in)
Aluminum							
Plexiglas							

The next step in both methods is to clamp the specimen into the tensile testing machine, but depending on whether the traditional method is exploiting the extensometer determines if there is a variation in the next step. If the traditional method is using the extensometer then both methods need to attach it to the specimen; if the traditional method is using the cross-member to measure elongation then only the non-traditional method needs to attach the extensometer. If using the traditional method, it is now time to start applying the load; if using the interface, the channels associated with the load and elongation must first be selected before applying the load. Once the test starts running, the only difference is the graph that the students see and the format of the raw data. With the traditional method, the students see a load versus elongation graph and get the data in ASCII format; with the interface, they see the stress-strain plot and have the data already in Excel. The more modern method also allows the students to have more accessibility to their data outside the lab because the interface can utilize a cloud storage service if desired.

3.8.4 Summary

The *Tension Test* is expected to provide the students of the Dynamics and Strength of Materials Laboratory with an understanding of the relationship between stress and strain using material properties such as the Modulus of Elasticity and Poisson's Ratio. This understanding will be evaluated by the students' laboratory report that is required following the completion of the lab. The traditional method is simple because it only uses one machine unless an extensometer is added to the setup. The developed interface is intended to improve the understanding of the subject matter and achievement of the objectives by showing the stress-strain curve in real time while also providing the students the raw data in a more student-friendly format than the traditional method. There are several differences between the methods but the main difference is how the students receive the raw data and the accessibility to the data outside of the lab. Overall, the interface is projected to improve the experience of the *Tension Test* experiment for the students.

3.9 Incorporation of Cloud Storage and Social Media

Cloud technology already has a large presence in remote laboratories because of the numerous advantages that it has to offer. The benefits of cloud technology include: virtual teamwork and flexibility. Virtual teamwork can be exploited by individuals or institutions. The cloud allows multiple people to work on a single project simultaneously without being anywhere near each other. In this same way, institutions can cut cost by "sharing". If one university already has a full lab setup established and connected to the cloud, and another university is

interested in offering that particular lab but does not have the resources to do so by itself and has cloud capabilities, the university lacking the lab could connect to the other university's lab equipment via the cloud and pay the other university a fee. This creates a win/win situation. The cloud also allows flexibility in a couple ways: time and location. Data stored on the cloud can be accessed anytime and anywhere that has internet access. The combination of these features makes the cloud an invaluable tool in many facets of life but especially in academia.

The use of a cloud storage service and social media to increase the accessibility to data outside of the lab has been mentioned in the previous 4 sections. This section provides the details of the cloud storage and social media in general as well as how these services are integrated into the interface. The cloud storage service that is being utilized is Google Drive and the social media is Google Plus. The reason Google products were chosen was because the West Virginia University email service is powered by Google. This means that each and every student has free access to both Drive and Plus which makes for a perfect fit.

There are many benefits to using cloud services powered by Google. A few of these benefits are: 1) security and privacy, 2) automatic synchronization of data, 3) edit report online, and 4) accessibility. Google provides the instructors a sense of security because the sharing options can only be adjusted by authorized users only. This means that students cannot copy other student's data and they cannot share with unauthorized individuals. Google Drive also syncs automatically which means that changes made while on the cloud are saved automatically. This also means that documents can be edited online so students can work on their reports from anywhere and any changes that they make will automatically be saved so there is no risk of lost data. Lastly, Google Drive provides incredible accessibility; all that is needed is the internet and a device capable of connecting to it.

Google Plus offers the students a chance to collaborate but prevents them from copying results. The students can use the chat service offered by Plus to talk with each other as they work through their reports. They can share photos of their results with other students but cannot share actual data files from the lab because the sharing options are managed by either the instructor or the teaching assistant. Students can also post progress reports on their page so the other group members know how much they have done. This is beneficial because if one person has already completed a section that another student is having trouble with the student that needs help can ask the person that has already done that particular part. Incorporation of social media into remote laboratories is not only a helpful addition but it also brings some fun to the lab.

One of the main focuses for this research was to create a way to provide increased accessibility to the data outside of the lab. It was mentioned that the user of each of the interfaces could choose the location to which the data would be saved. Google Drive has a feature called Google Drive Desktop that, when downloaded, creates a “Google Drive” folder on the user’s desktop. The feature was added to one of the computers used in the MAE 244 lab. Therefore, if the instructor wishes to utilize this cloud application offered by Google, the save location should be the “Google Drive” folder on the desktop. As long as the instructor/TA is signed-in to Google Drive Desktop, all folders and files will be synchronized with the cloud Google Drive thus all folders and files in the desktop version of Drive will be added to the cloud. If that is the case, each “Section # - Group #” folder will be created within the Google Drive Desktop and as data from the experiments are saved into these folders they will be added to the cloud. Once on the cloud, the students will have access to these files anywhere they can connect to the internet, even on mobile some mobile devices.

The sharing has not been automated at this time so it is the responsibility of the instructor or TA to configure the sharing options for each folder. After each folder is first created, or if the instructor or TA chooses to create these folders beforehand, the instructor or TA can assign the email address of each group member to the corresponding folders. This will allow the files to be shared automatically when they are synchronized to the cloud but only to the members of the group. After the students have the files in their own, personal Drive, they have some additional sharing options. The students could start a “Google Doc” for their laboratory report so that they can work on their report anyway without having to carry around a computer or flash drive. They can also share the data and/or report to their Google Plus page so that others in their circle can see what they are working on.

3.10 Chapter Summary

MAE 244: Dynamics and Strength of Materials Laboratory is designed to enhance the students’ learning and understanding of topics discussed in the pre-requisite courses including Statics, Dynamics, and Mechanics of Materials. In an effort to better accomplish this task, this research focused on developing graphical user interfaces for experiments that used P3 Strain Indicators and Recorders to allow the students to focus more on the experiment being conducted rather than recording the data and to improve the accessibility to this data outside of the lab by employing Google Drive. Microsoft Visual studio 2010 was used to develop each of the interfaces and each of the interfaces connects to a P3 Strain Indicator and Recording, manufactured by Micro-Measurements, and utilizes the corresponding software. Four interfaces were created in total, one for each of the following four experiments: Beam Bending, Combined

Loading, Pressure Vessel, and Tension Test. The traditional method and the method employing the interfaces for each of the experiments are similar. The main differences being the format of the raw data, how the data is stored, and the accessibility to the data outside of the lab. The combination of these features will improve the experience for the students enrolled in this course.

Chapter 4: Results from Surveys

The results of this research are largely based on the survey responses from 10 students who agreed to do a comparison between the traditional method and one that uses the developed interfaces. These 10 students were all undergraduates at WVU and were provided with the letter displayed in Appendix A. The students were required to be currently enrolled in MAE 244 or already have completed the course. The students performed the *Beam Bending* and *Combined Loading* experiments using the traditional method and then again using the interface. After each of the experiments the students filled out a survey comprised of Likert scale questions and open-ended questions. The Likert scale ranges from 1 to 5 with the following linguistic values respectively: Strongly Disagree, Disagree, Neutral, Agree, Strongly Agree. After each of the experiment specific surveys had been completed, the students' last task was to fill out a survey about the interfaces as a whole. The 3 surveys were summarized into bar graphs or a list of responses, based on the type of question, for each question. The results from each survey will be discussed in the 3 subsequent sections.

4.1 Beam Bending Student Survey Responses

The *Beam Bending* survey consisted of two parts for a total of 14 questions. A sample of this survey is shown in Appendix D. The first 7 were multiple-choice, Likert scale questions and the last 7 were open-ended. Each Likert scale question was summarized, based on the numeric score, into a bar graph in Excel and then the average and standard deviation were calculated.

The open-ended questions were summarized by transcribing the responses from each student into a list so as to group the responses by question. The results from these questions are presented below.

One of the design goals for the interface was to make it user friendly and to save time when compared to the traditional method. Questions 3 and 4 were posed to specifically answer these questions; the results are shown in Figure 4-1 and 4-2.

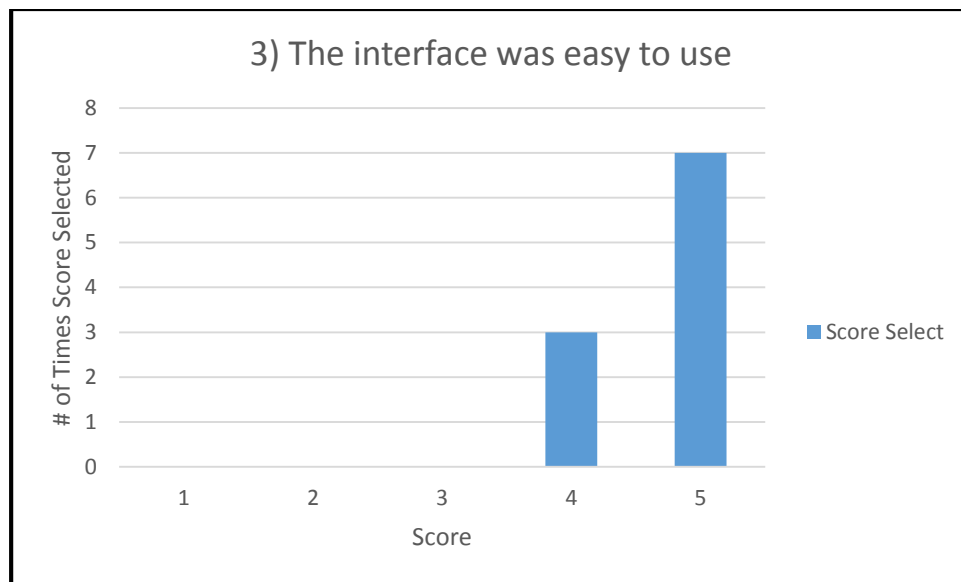

Figure 4-1: Beam Bending Question 3 [Avg. 4.7, Std. Dev. 0.48]

All 10 participants at least agreed that the interface was easy to use and 70 percent strongly agreed. According to Figure 4-2, almost all of the participants thought that using the interface saved time overall as 9 of 10 participants strongly agreed with this statement. These results seem to suggest that the goal of creating a time-saving, easy-to-use graphical user interface was accomplished.

One thing the interface offers that the traditional method cannot is a graphical display of the deflections in real time. This feature was added with the objective of improving the students

understanding of what was actually happening during the experiment. The following 3 questions were concerned with this aspect of the design: Question 5 asked if the participants liked having the graphical display of the deflections, Question 6 asked if the display improved their understanding, and Question 7 asked if the real-time calculations and display were not helpful.

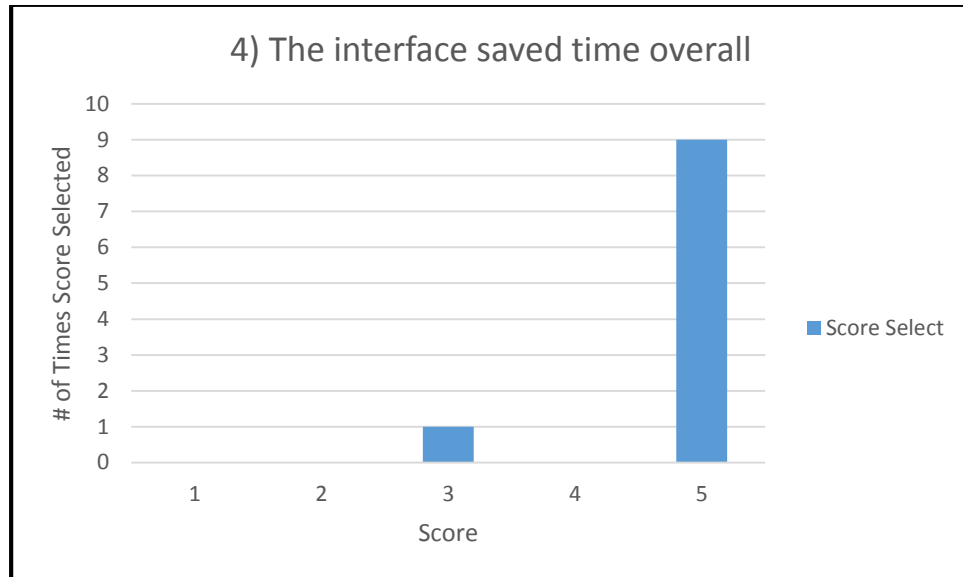

Figure 4-2: Beam Bending Question 4 [Avg. 4.8, Std. Dev. 0.63]

The scores for Question 5 are very positive with an average of 4.7 and a standard deviation of 0.48, it is clear that all of the participants liked having the graphical display. Question 7 is phrased such that a low score suggests that the participants think the display is helpful. The average score for Question 7 is 1.2 and the standard deviation is 0.63 which implies that all of the participants thought the display was helpful. Now that it has been established that the participants like the display and think it is helpful, the real question can be answered: Does the display improve the understanding of the *Beam Bending* lab?

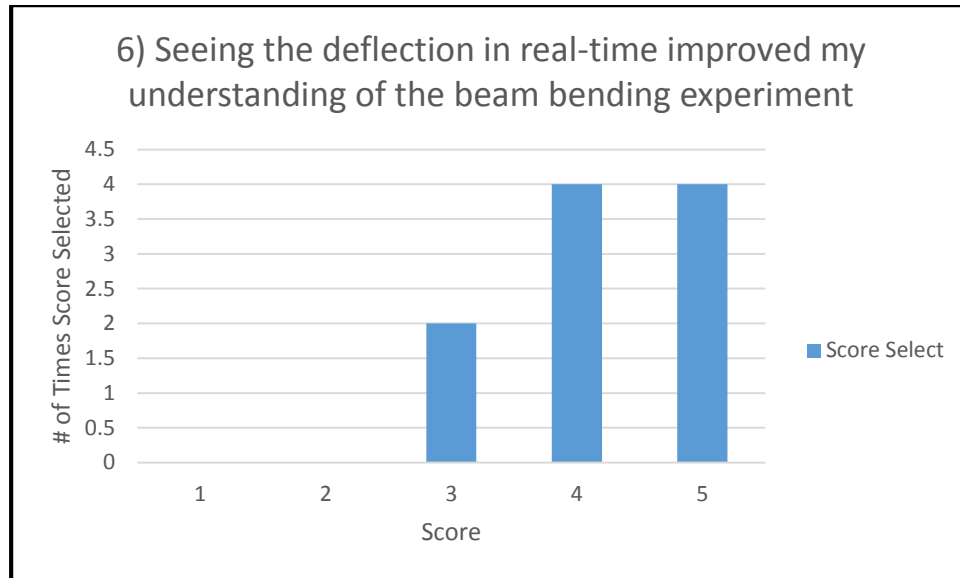

Figure 4-3: Beam Bending Question 6 [Avg. 4.2, Std. Dev. 0.79]

According to Figure 4-3, the responses are all positive but there does not seem to be an agreement about how much it improves the understanding. This variation could be caused by the fact that different people learn in different ways so perhaps the participants that gave a score of “3” are not visual learners but the ones that scored a “5” are. The important thing is that none of the students thought it negatively affected their understanding and 8 out of 10 thought it improved their understanding to some degree.

The learning outcomes are an important part of any course so it was imperative that the outcomes for this experiment were not negatively affected by the use of the interface. The data for this aspect is open to interpretation because Question 2, a Likert scale question, has at least 1 tally for each of the 5 scores but Question 12, which asks, “How do you think the interfaces affect the learning outcomes of the beam bending experiment?”, has all positive comments, with over half citing the real time graphical deflection display. Some of the comments made include, “Not at all, you see how the experiment works real time with the graphs” and “The overall outcomes may be slightly more beneficial, by observing the real time plots”. However,

according to Figure 4-4, the interface may or may not be detrimental to the learning outcomes. Sixty percent of the participants disagree that the interface negatively affects the learning outcomes while the remaining 4 participants are either indifferent or think the interfaces has a negative effect on the outcomes. It is possible that there was confusing about what the question was asking but at this point it is difficult to know for sure. Based on the responses to Question 12 and the fact that over half of the participants did select a low score for Question 2 that implies that the interface is not detrimental, it can be assumed that the learning outcomes are, in fact, improved by the interface.

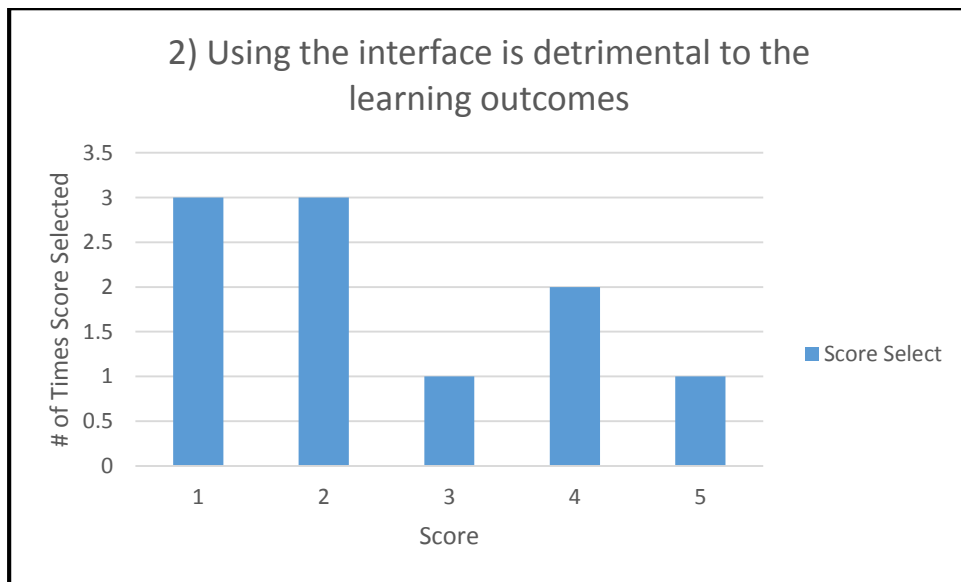

Figure 4-4: Beam Bending Question 2 [Avg. 2.5, Std. Dev. 1.43]

The participants were asked what changes they would make and, also, how they would explain the interface to a friend. Some of the changes that were suggested include, “Larger window”, “Add an option for unit inputs”, and “The ability to redo a test”. When asked how they would describe the interface to a friend, the words “simple” and “easy to use” appear multiple times. One participant said they would explain the interface as, “Essentially, it takes

down all the data for you and creates the excel sheet you need to do to finish the lab and you can access it through Google Drive any time”. According to these responses, the attempt to make a simple, easy-to-use interface was successful and the suggested changes would be fairly easy to implement.

Questions 1, 8, 9, 10, and 11 pertained to what the students liked and disliked about each method and which one they preferred. Questions 8 and 9 asked the students to describe what they liked about the interface and traditional method, respectively. The responses about the interface were all positive and suggested that it was easy to use and seemed to save time. One student commented, “It was quick, easier and saved a lot of time”. Most of the students had nothing that they liked about the traditional method but one student did like one thing, he stated: “I like physically having data in my hand (paper)”. The combination of responses from Question 8 and 9 suggests that the students do not really like the traditional method and think the interface positively affects the experimental procedure.

Questions 10 and 11 asked the students, “Describe what you disliked about the interface” and “Describe what you disliked about the traditional method”, respectively. The majority of the students stated that they disliked something about the interface, most of these comments were related to how the data had to be entered into the interface and the fact that mistakes made while entering the data could not be corrected. One student phrased his thoughts as such: “Hard to go back and change values”. The common theme for Question 9 seems to be that the participants did not like having to record the data by hand, having to enter it into Excel themselves, and having to deal with making sure each group member had the correct data. One participant wrote, “It was a pain to have to write everything down between 4 people and then input it all into Excel”. Based on the responses to these two questions, it would seem that although they thought

some changes could be made to improve the interface, they dislike the data acquisition process in the traditional method.

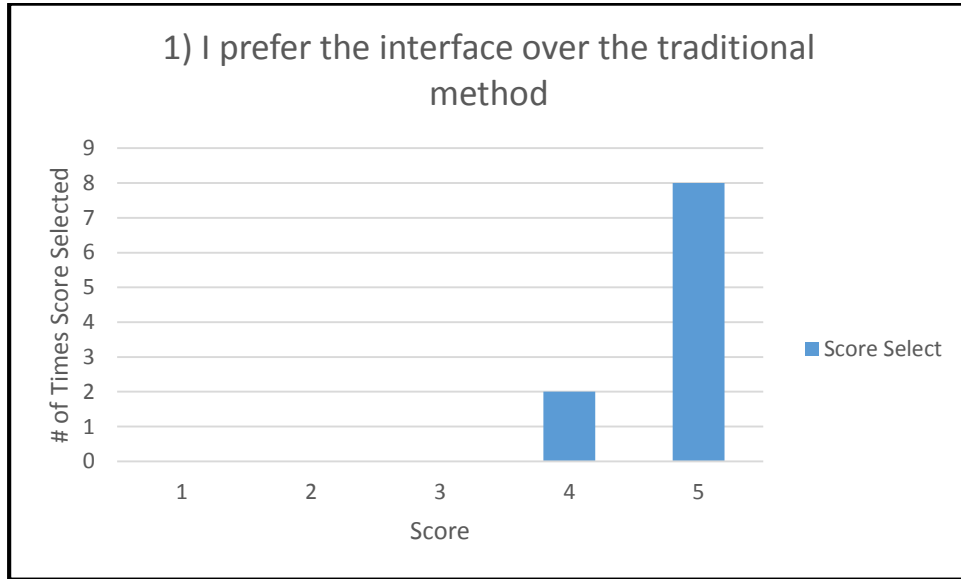

Figure 4-5: Beam Bending Question 1 [Avg. 4.8, Std. Dev. 0.42]

Question 1, a Likert scale question, sums up Questions 8 through 11 by posing the statement, “I prefer the interface over the traditional method”. Figure 4-5 shows the results of Question 1 as a bar graph. With an average of 4.8, it overwhelmingly favors the interface and, as shown in Figure 1, all of the students either “Agreed” or “Strongly Agree” with the posed statement. According to the responses from this survey, it is evident that the participants think the interface would have a positive effect on the *Beam Bending* lab but does require some minor adjustments.

4.2 Combined Loading Student Survey Responses

The *Combined Loading* survey was comprised of two different types of questions for a total of 13 questions. A sample of this survey is shown in Appendix D. The first 6 questions were Likert scale questions with possible choices ranging from 1 to 5 and the last 7 were left open-ended for the students to fill out using their own words. In order to summarize the results of this survey, the Likert scale questions were put into Excel where the average score and standard deviation were calculated and bar graph was created for each question. For the Likert scale questions, 1 represented the linguistic value “Strongly Disagree” and 5 represented “Strongly Agree”, with 2, 3, and 4 evenly filling the middle of the linguistic range. The opened ended responses from each student for each question were all grouped together so that all responses for each question could be viewed together. The following analysis is based on the combination of responses from both sets of questions.

The most important aspect of the interface design was that it was easy to use and, consequently, would save time. Questions 3 and 4 from the survey required the participants to respond to the following statements, respectively: “The interface was easy to use” and “The interface saved time overall”. The response to Question 3 left no room for doubt as 10 of out 10 students selected a score of 5, or “Strongly Agree”. This is an excellent response considering that this was a primary concern of the design.

While not all 5’s, whether or not the interface saved time overall received an extremely positive response scoring an average of 4.8 and a standard deviation of 0.42, the bar graph is shown in Figure 4- 6. This graph shows that the participants felt relatively strongly that the interface did save time. The fact that the combination of these responses was extremely positive suggests that the interface was well designed and efficient.

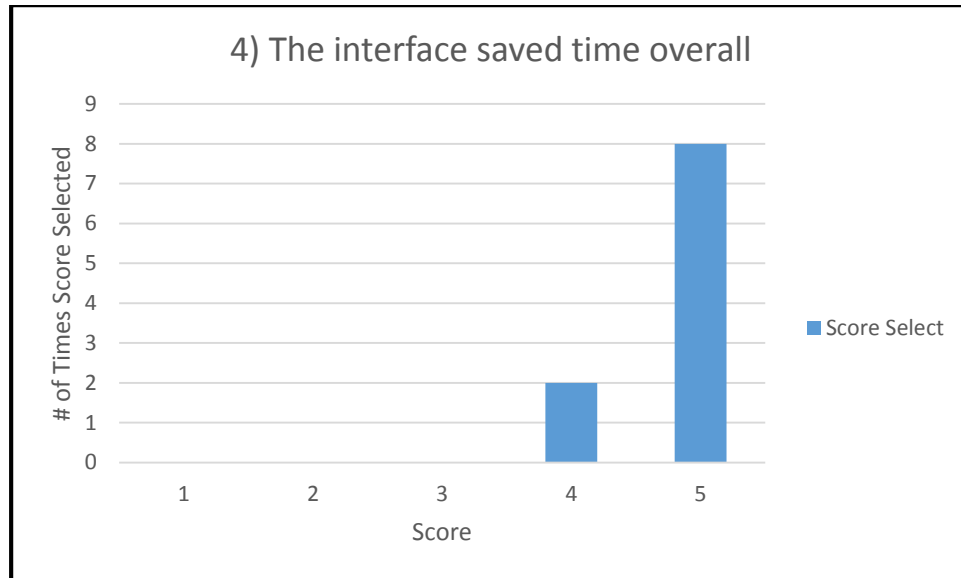

Figure 4-6: Combined Loading Question 4 [Avg. 4.8, Std. Dev. 0.42]

It was also important that the interface enhanced the understanding of the concept being presented and did not negatively influence the learning outcomes of the lab. Questions 2, 5, 6, and 12 were related to this aspect of the experimentation. Question 5 asked the students to respond to the following statement, “Seeing the strain vs load graphically helped me understand their relationship”, while Question 6 stated, “Having the real-time calculations and graphical display was not helpful”. Question 12 asked the participants, ‘How do you think the interface affects the learning outcomes of the combined loading experiment?’ and Question 2 required a Likert scale response to, “Using the interface is detrimental to the learning outcomes”. The responses to these questions should be consistent with each other and reflect a positive attitude.

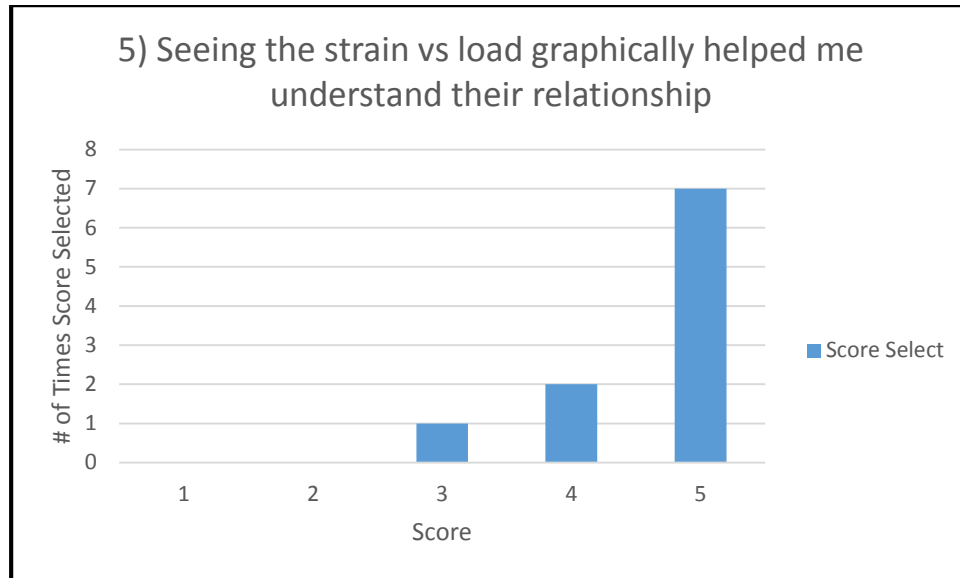

Figure 4-7: Combined Loading Question 5 [Avg. 4.6, Std. Dev. 0.7]

Since Question 6 was a “not” question, a positive response means the participants should have selected 1 or 2. A score of “1” was selected 8 times, and “3” and “5” were each selected once making the average 1.6 and the standard deviation 1.35. This suggests that a large majority of the participants felt that the real-time calculations and graphical display were helpful. This leads into Question 5 since the graphical display is a graph of the stress versus the strain which was expected to improve the understanding of the experiment. Ninety percent of the responses were positive while the remaining participant was indifferent. This can be seen in Figure 4-7 and the data for this question has an average of 4.6 and a standard deviation of 0.7. Positive responses for Questions 5 and 6 bode well for positive responses for Questions 2 and 12.

While Questions 12 and 2 are both asking about the learning outcomes, the responses are surprisingly inconsistent. Question 12 displays a positive vibe with comments such as, “It advances the outcomes by showing visual results of the experiment” and “The interface improves learning outcomes by better displaying the relationships of load and strain”. On the other hand, Question 2, which asked if the interface was detrimental to the outcomes, has an

average score of 2.7 accompanied by a standard deviation of 1.34; the bar graph for Question 2 is shown in Figure 4-8. Given the overwhelmingly positive response from Question 12 and the indecisive response from Question 2, coupled by the positive responses from the previous paragraphs, it is a strong possibility that the participants misunderstood the question being asked in Question 2. Even without assuming that participants misread or misunderstood Question 2, the responses of these 4 questions as a whole suggest that the interface is beneficial to the understanding of the lab and at least slightly improve the learning outcomes.

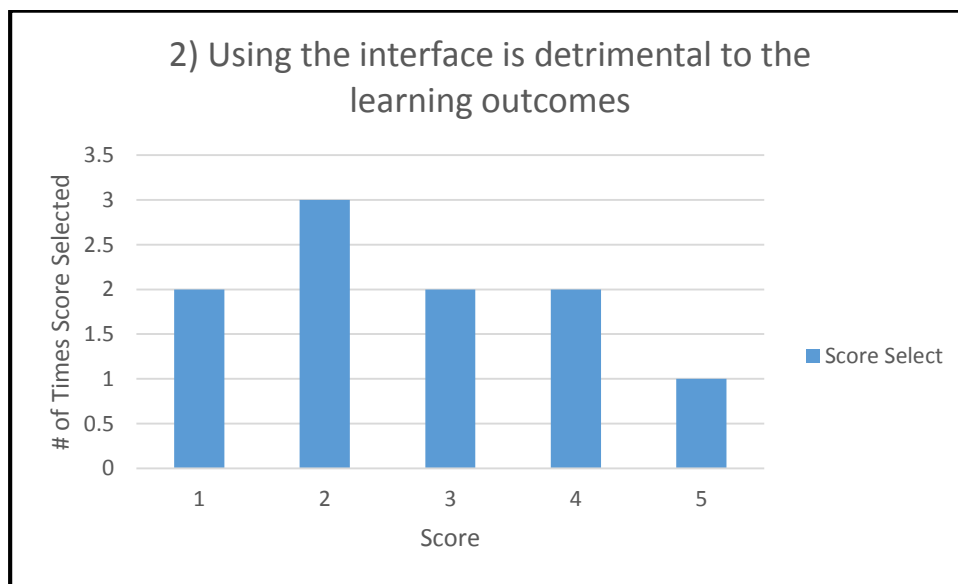

Figure 4-8: Combined Loading Question 2 [Avg. 2.7, Std. Dev. 1.34]

Still focusing on only the interface and not including how it affects the traditional method, the students were asked “What changes would you make to the interface?” and “How would you explain the interface to a friend?” in Questions 13 and 14, respectively. Participants suggested making some of the same changes as in the *Beam Bending* lab, these changes include, “Add an option for unit selection, possibly an undo button” and “All for data to be changed while doing experiment”. The participants’ descriptions to friends are also similar to how they would

describe the *Beam Bending* interface. Some of the comments given by the participants are, “Very helpful and time friendly”, “A real-time record of your experimental results”, and “Involves steps, but it is essentially a real time data sheet”. The descriptions given by the participants closely resembles the original design characteristics of the interfaces and the suggested changes are minor and would be easy to implement.

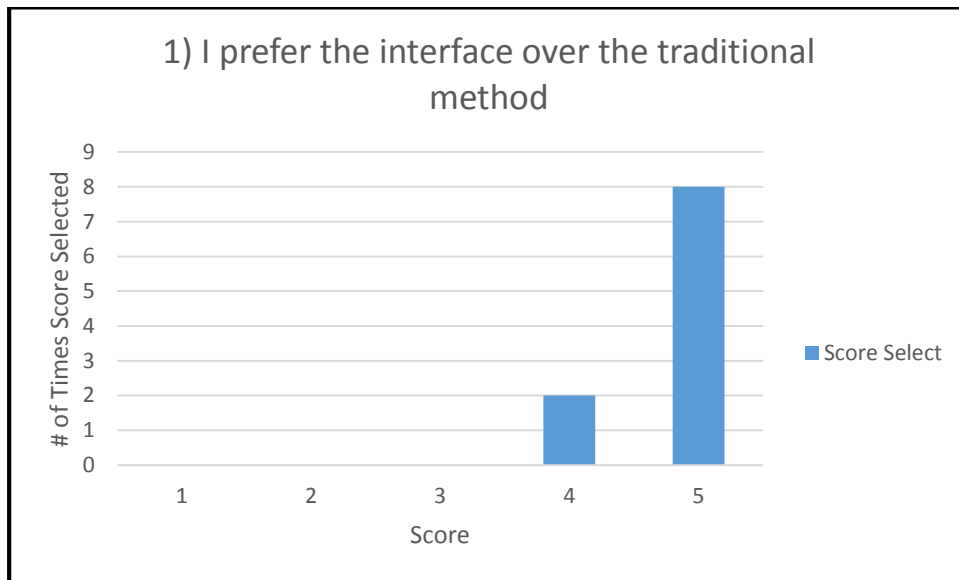

Figure 4-9: Combined Loading Question 1 [Avg. 4.8, Std. Dev. 0.42]

The final part of this analysis is to determine how the participants felt about the interface compared to the traditional method of performing the experiment. The final 5 questions are responsible for providing a solution to this query. Questions 8 and 9 ask the students what they like about each method, Questions 10 and 11 ask what they did not like about each method, and the Question 1 essentially asks if they prefer the interface method over the traditional method. The responses to these questions are vital to determining whether or not the interfaces should be incorporated into the lab.

The participants were first asked what they liked about each method. For the traditional method, a few students said that they liked having a hard copy of the data but most did not like anything about the method. On the other hand, the participants seemed to like a number of things offered by the interface. Some comments left by the participants include, “A lot faster than traditional method, saves data so it is available outside of class from Google Drive” and “ I liked being able to see real-time graphical comparisons of the results”. The participants had plenty to say when asked to “Describe what you disliked about the traditional method”. The overwhelming response was that they did not like having to write down the data by hand; this claim is support by responses such as, “Data collection is a pain”, “You have to write down the data”, and “The data recording focus can take away from observations leading to the theoretical to real life connections”. The main thing that the participants disliked about the interface was that there was no way to correct a data entry error; some other comments included: “Not everyone got to see the data” and “Interface did not have a units option”. The culmination of these 4 questions was manifested in Question 1 which requires the participants to respond to, “I prefer the interface over the traditional method”. The results of this question are shown in Figure 4-9.

Eighty percent of the participants said they “Strongly Agreed” with this statement and the remaining 20% gave a score of 4, or “Agree”; this leads to average of 4.8 and a standard deviation of 0.42. While there are some minor adjustments that the participants would like to see in the interface, it is apparent that they feel that the method employing the interface is superior to the traditional method.

4.3 Overall/General Student Survey Responses

The third and final survey was intended to gather thoughts and feelings from participants about the interfaces collectively. A sample of this survey is shown in Appendix D. This survey included 9 Likert scale questions and 5 free response questions. The Likert scale was the same as for the previously discussed surveys with 1 through 5 being “Strongly Disagree”, “Disagree”, “Indifferent”, “Agree”, and “Strongly Agree”. The questions were geared towards determining if the participants felt that the interfaces should be implemented in the MAE 244 course. Some questions are meant to summarize the responses from the two experiment specific surveys while others were concerned with the big picture.

The best question to begin this analysis is Question 11, which asks, “How would you describe your experience with using the interfaces collectively”? The responses were positive overall but the following comments expressed some minor concerns, “Overall, good. Some minor bugs to work out but shows good promise” and “It was easy and quick but it may affect some students who didn’t understand how the results were calculated because the interfaces doesn’t show them”. On the contrary, one participant described the experience as, “Awesome. I wish they had these for literally every lab”! Most of the other comments talk about how easy the interface was to use and how much easier it made the lab. A positive student experience is a key step towards the implementation of the interfaces into the lab.

The aim of 3 of the questions was to discuss the strengths and weaknesses of the interfaces as a whole and suggest modifications. Questions 12, 13, and 14 asked the participants what they would change, what they thought the strengths of the interface method was when compared to the traditional method, and what they thought the weaknesses were, respectively.

The suggestions for modifications included, “Larger interface window”, “Animations for a better visual concept. Make it easier to go back and change values”, and “Allow the interface to be more flexible”. These suggestions are similar to those expressed for experiment specific surveys. The strengths can be reduced to faster, better accessibility to data, and better understanding with real-time graphs. Some of the responses given were, “Digital data records that are accessible anywhere. Data turned into plots instantly” and “The real time graphical results act as a visual aid of understanding the theory behind the experiment”. There were fewer comments given about the weaknesses of the interface method and they were mostly related to the suggested modifications except for one which expressed a concern that, “...it reduces one’s experience with Excel”. The responses to these questions show that there is still some work to be done for the interfaces but they offer several benefits that the traditional method cannot.

Almost half of the survey questions addressed the ease of use and efficiency aspects of the interfaces. As mentioned previously, one of the main concerns for the interface was that it was easy to use. The response to Question 5, a Likert scale question stating “The user interfaces were easy to use”, was positive with a 60/40 split between “Strongly Agree” and “Agree”, respectively. The bar graph for Question 5 is shown in Figure 4-10.

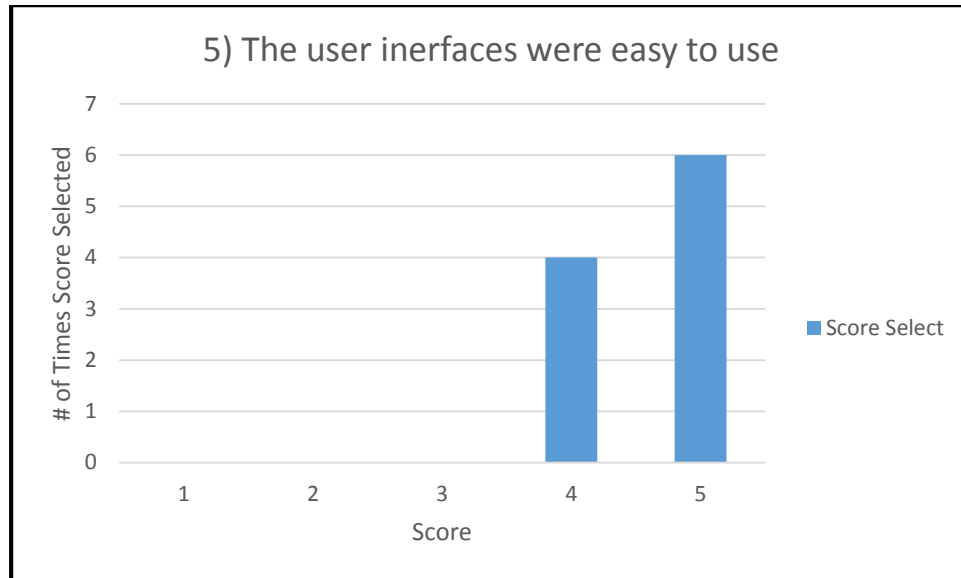

Figure 4-10: General Question 5 [Avg. 4.6, Std. Dev. 0.52]

One of the main difference between the interface and traditional method is that students do not have to write anything when they use the interface. Question 9 asked if this was “favorable”, the response was positive with an average score of 4.6 and a standard deviation of 0.7. Improving data extraction and accessibility to data outside of the lab were also important features that the interface attempted to address. Nine out of 10 participants “Strongly Agreed” that the interface made data extraction easier while the last one selected “Disagree”; this yields an average score of 4.7 and a standard deviation of 0.95. Eighty percent of the participants “Strongly Agreed” that utilizing Google Drive made their data more accessible outside of the laboratory, the other 2 participants only “Agreed”. These results are shown in Figure 4-11.

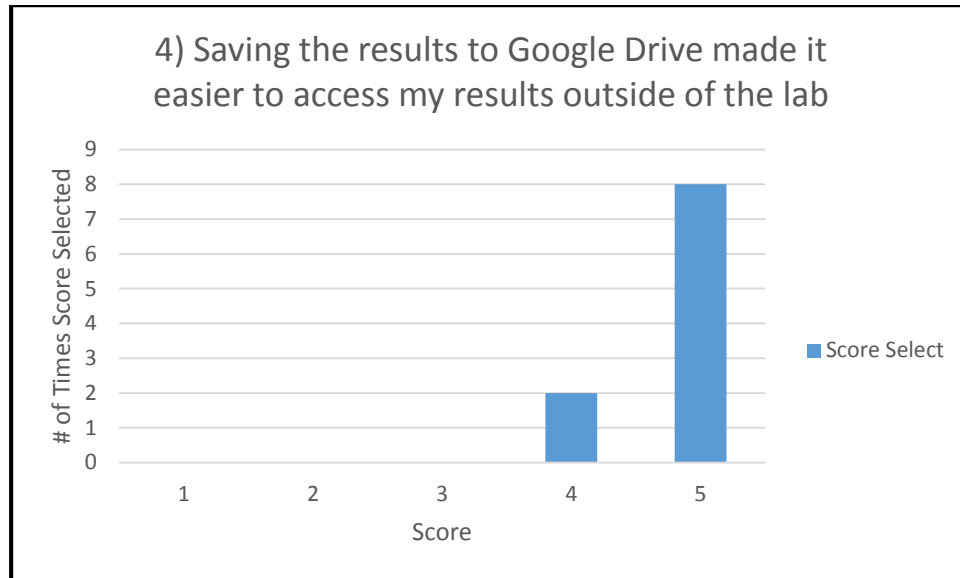

Figure 4-11: General Question 4 [Avg. 4.8, Std. Dev. 0.42]

The fact that students already have the raw data in Excel is something the traditional method cannot provide. It was hypothesized that already having the data in Excel would be beneficial when writing the lab report, when the participants were asked this question the response was extremely positive. All of the participants thought the Excel formatted data would be beneficial although not to the same degree; one participant chose “Agree” to answer this question, while the other nine selected “Strongly Agree”. While no quantitative comparison are available for this question, the fact that the average score was 4.9 with a standard deviation of 0.32 would suggest that the quantitative results would most likely be good.

The summation of the 5 previously discussed questions can be displayed in Question 6, “The user interfaces improved the overall lab experience”. This question is also related to the first question presented in this section and yields similarly positive results. The results of Question 6, shown in Figure 4-12, advocate that the interfaces are a beneficial addition to the lab as a whole. Although the participants seem to think that the interface is easy to use and advantageous, it is crucial that the learning outcomes are not compromised.

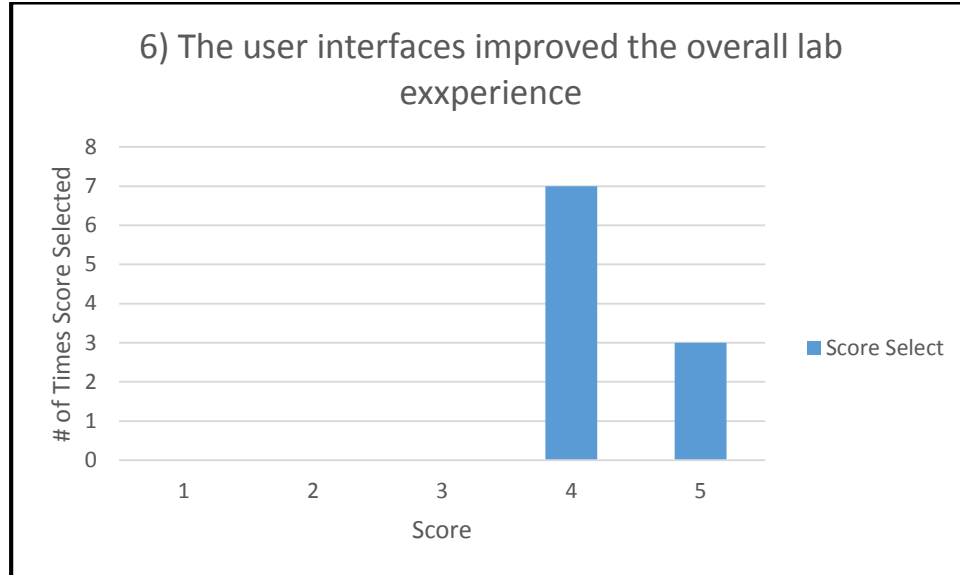

Figure 4-12: General Question 6 [Avg. 4.3, Std. Dev. 0.48]

To determine how the learning outcomes were affected, three questions were posed to the participants: Question 1, “The user interfaces helped me to understand the experiment better”, Question 8, “The interfaces, as a whole, improve the learning outcomes of the experiments”, and, Question 15, “How do you think the interfaces affect the learning outcomes of the selected experiments collectively”? The response to Question 1 is undeniably positive with an average of 4.6 and a standard deviation of 0.5. The results of Question 8 produce an average score of 4.4 with a standard deviation of 0.7 which match with the positive comments given in Question 15. The bar graph for Question 8 is displayed in Figure 4-13.

As a whole, the responses from Question 15 suggests that the interface would improve the learning outcomes; some comments to support this claim are, “There is great potential for the interfaces to have a positive impact if the lab T.A. keeps the group focused and displays the real-time data to the group” and “The interfaces make the data easier to interpret and makes data

more available”. These responses propose that as a result of the interfaces improving the understanding of the experiments, the learning outcomes are also improved.

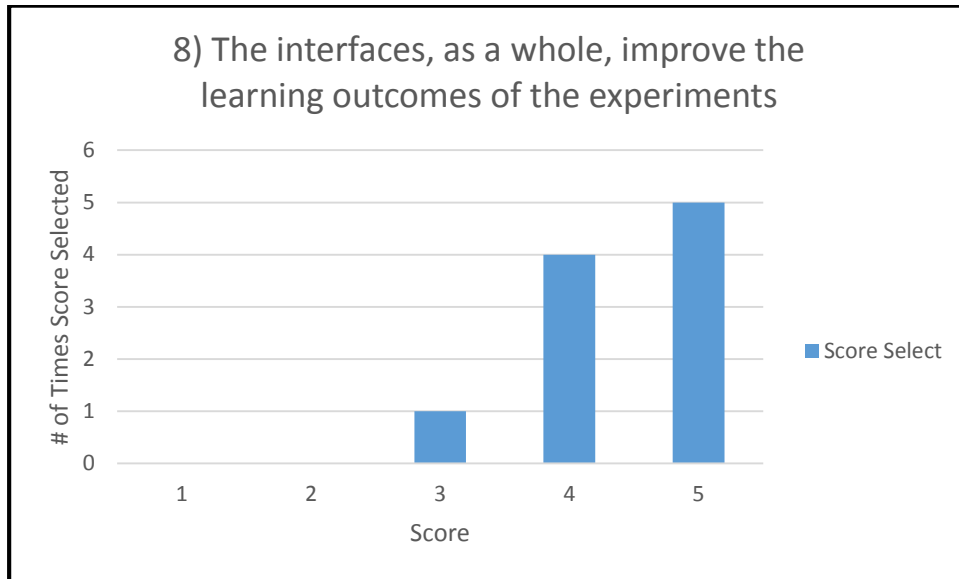

Figure 4-13: General Question 8 [Avg. 4.4, Std. Dev. 0.7]

All of the questions presented in this section lead up to one, ultimate question: “Should the interfaces be added to the MAE 244 course”? The tremendously positive response in each of the three surveys would imply that the answer would be “yes”; however, Question 7 of the last survey was designed to specifically answer this question. Question 7 asks the participants to respond to the following statement, “I would suggest implementing the interfaces into the MAE 244 course”. The average score was 4.9 with a standard deviation of 0.3 and the bar graph is shown below in Figure 4-14. While there are some modifications that would need to be made before the interfaces could be incorporated fully into the course, the positive responses from the participants in the study seem to suggest that the interfaces would be a welcomed addition to the laboratory.

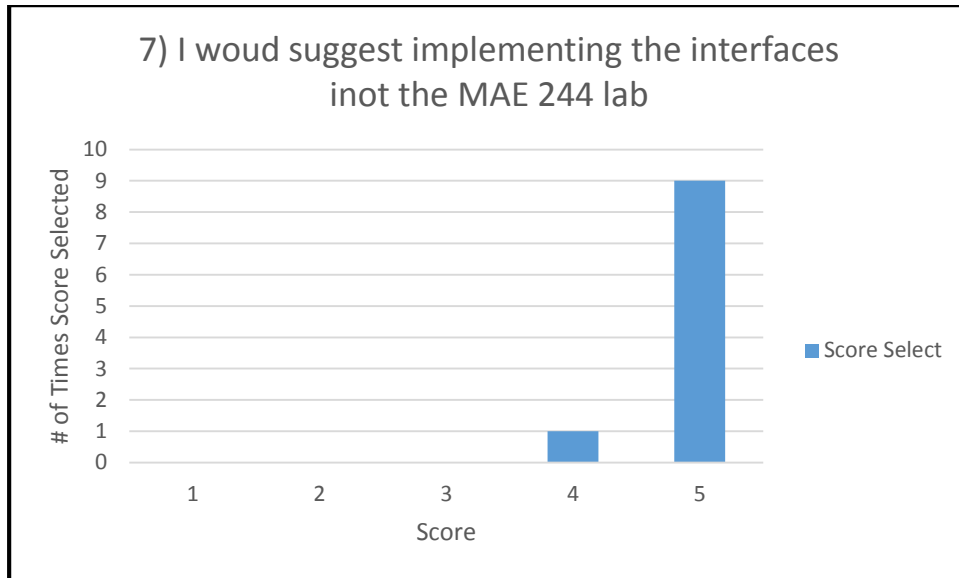

Figure 4-14: General Question 7 [Avg. 4.9, Std. Dev. 0.32]

To put these results in perspective, the table shown in Table 4-1 was created. This table serves as a comparison of similar Likert scale questions asked in each of the lab specific surveys. For each question, the average of the average scores for each experiment were calculated and placed in the far right column of Table 4-1. What this table is able to do is show how the participants felt about the interfaces overall. Getting the average of the averages offers a sense of how the interfaces were rated collectively.

The resulting average exhibited in the fourth column of Table 4-1 reveals an overall positive attitude about the interfaces. The first question presented in the table which asked if the participants preferred the interface methods over the traditional methods received an average score of 4.8 out a possible 5.0. This leaves little room for doubt that the interfaces would be a welcome addition to the lab procedure. The second question is the only one that has a “negative” score and it pertains to whether the participants felt that the interfaces were detrimental to the learning outcomes of the labs. The score is just above the center of the range which suggests that

the participants were unable to come to a consensus on this topic. Other questions related to the learning outcomes imply that the participants felt that the learning outcomes were enhanced.

Table 4-1: Comparison of Likert Scale Survey Questions

Question	Beam Bending Average Score	Combined Loading Average Score	Total Average
I prefer the interface over the traditional method	4.8	4.8	4.8
Using the interface is detrimental to the learning outcomes	2.5	2.7	2.6
The interface was easy to use	4.7	5	4.85
The interface saved time overall	4.8	4.8	4.8
Seeing the graphical display improved my understanding	4.2	4.6	4.4
Having the real-time calculations and graphical display was not helpful	1.2	1.6	1.4

The third and fourth question ask the participants to respond to whether they think the interface was easy to use and if it saved time overall. The total average of each of these questions is 4.85 and 4.8, respectively. The interfaces need to be easy to use because otherwise a large amount of time would be required to teach the students how to use it which would be counter-productive. With a score of almost 5 out of 5, it is obvious that this requirement was fulfilled. Ideally, the interfaces should save time; if not, their appeal would be diminished. Fortunately, this category received almost a full mark which means the participants thought the interfaces did save time. Saving time in the lab is important because it can be difficult to retain the students' attention for long periods of time.

The last two questions ask the same question, but in an opposite manner, with the common goal of ascertaining if the participants felt that the graphical displays in the interfaces were beneficial for the students' understanding of the experiments. The 5th question should be given a high score to reflect a positive view and, since the 6th question contains a "not", a lower score would reflect a positive assessment. With a score of 4.2 and 1.2 for the 5th and 6th

questions displayed in Table 4-1, it can be concluded that the participants thought the understanding of both experiments was improved due to the graphical display of the data. The students' understanding of the labs was a major concern involved in this research. The goal for courses is always to help students understand a particular subject better; it is no different in a lab. The results from the final two questions suggest that this objective was fulfilled.

Except for a few questions that appeared to have a split decision, the results of this research were extremely positive. The participants felt that the interfaces were easy to use and saved time which were chief concerns during the development. The participants also felt that the graphical display enriched their understanding of the subject matter which should always be a key issue for all things related to academia. Ultimately, the participants said they preferred the interface method over the traditional one so the next step should be to expand the study to a larger number of participants or do a trial implementation of the interfaces into the lab to definitively determine if these interfaces can improve the complete lab experience in MAE 244.

Chapter 5: Conclusion

5.1 Contribution of This Work

The main contribution of this research is that it is the first step towards the development of a remote laboratory at College of Engineering and Mineral Resources at West Virginia University. By successfully integrating the hardware and software from the lab into an easy-to-use graphical user interface, the data acquisition process has been improved and the laboratory has been connect to the “cloud”. This was done in an effort to renovate an otherwise manually operated and outdated Dynamic and Strength of Materials lab. Several of the experiments from this lab have had interfaces created for them, two of which have been tested by students and were determined to be extremely beneficial. The connection to the “cloud” allows data to be stored and shared in a much grander fashion than ever. By utilizing cloud technology for storage, students and instructors have access to the data from any location and device that is able to connect to the internet. This research may only be a small portion of what is required to achieve the ultimate goal but it has provided an excellent beginning to the development of a fully-functional remote laboratory.

5.2 Achievement of Integrating Works

The results presented in Chapter 4 were an analysis of survey responses from students that agreed to participate in this study. The conclusions drawn will be based on these analyses.

The main objectives that were established for this research were: 1) the interface should be easy to use, 2) the interface should improve the efficiency of the lab, 3) the data should be more accessible outside of the lab, and 4) enhance the learning outcomes of each lab. The survey responses do not constitute quantitative results but do serve to represent the feelings and thoughts that students have about the interface compared to the traditional method. Quantitative results will be discussed in the “Future Works” section.

The first requirement for interfaces was that had to be easy to use. Easy to use means that the students only need a quick tutorial to understand the interface otherwise it will conflict with the second objective. This is important because instructors will not want to implement something that complicates the lab procedure because it makes their job more difficult. In all three of the surveys, the responses to questions concerning the “ease of use” of the interface were all positive and many were exceedingly positive. Based on Chapter 4, it is obvious that the participants considered the interfaces easy to use.

The interface should also improve the efficiency of the experiments performed in the laboratory. In today’s society, efficiency is everything. People do not want to spend more time performing a task than is necessary. The participants were queried as to whether they felt that the interface saved time and the responses were once again positive. While it cannot be definitively concluded that the interfaces do save time because of lacking quantitative results, it can be concluded that the interface is likely to save time based on the thoughts of the participants involved in this research.

In addition to saving time during the experiment, the participants were also asked whether they thought the data produced by the interface would save time when writing the required report. Again, these conclusions are not definitive because they lack sufficient

quantitative evidence. The responses to these questions indicated that the students felt that it would make writing the lab report easier and more efficient. The reasons being that it was already in an Excel spreadsheet which is something the students would normally have to do manually and, by utilizing Google Drive, they could access their data whenever they had free time to work on the report. These results strongly suggest the likelihood that the interfaces could improve the efficiency of the post processing associated with each lab.

The accessibility to data outside of the lab is a key feature of this research. The interfaces were designed with the plan to incorporate a cloud storage technology into the lab. Google Drive was the cloud storage chosen because all WVU students have access to Google Drive and it can be accessed via a folder on the desktop of a PC. Google Drive is also capable of connecting the students via Google's social media, Google Plus, which was a unique goal of this research. The fact that data can be accessed from anywhere that has an internet connection significantly improves the accessibility outside of the lab and the participants' responses support that claim. There is no data to support or suggest that this improves any other aspect of the lab other than the participants that listed it as a reason as to why they felt the report writing process would be more efficient as a result of having the interface.

Finally, successful completion of learning outcomes is paramount to ensuring that students gain the understanding of the concepts presented in the course. The participants were asked how they thought the interfaces affected the learning outcomes for each experiment. All of the students thought the learning outcomes were improved by the interface with the main reason being the real-time graphical display of the data. The graphical display was not originally in the interface design but was added for the sole purpose of enhancing the understanding of the experiment by visually showing what was happening. Although no quantitative studies were

performed, it is reasonable to assume that the inclusion of a visual aid boosts the learning outcomes for some students.

5.3 Technical Difficulties and Deviation from Original Plan

As with many things, this research did not go as originally planned. There were several issues that occurred including equipment malfunctions, lack of proper equipment, and unforeseen complications that prevented the full completion of the initial proposal. It may have been noticed that 4 interfaces were designed for 4 experiments but only 2 experiments were performed and discussed in Chapter 4. This as well as some details about the interfaces that were tested are a direct result of these impediments

5.3.1 Tension Test

The *Tension Test* was one of the experiments chosen to have an interfaces developed. This interface was different than the other ones because it was time based not step based. Meaning that once it started, it ran until the experiment was completed for that specimen whereas the other interfaces require user commands as each step in the procedure is completed. It also required a unique configuration with the P3 Strain Indicator and Recorder because a load cell and extensometer were used instead of strain gages. These elements were able to be used because of the machine used for the tests in the Spring 2013 semester when this research began. However, that machine was not reliable and was replaced by the department with a much newer machine for tensile testing. Although the extensometer could have still be used, the previously

used load cell was not be able to be connected with the new instrument therefore preventing the interface from being used in the way it was intended. As a result of this complication and limited time, it was decided to exclude the *Tension Test* from the final student evaluation.

5.3.2 Pressure Vessel

The *Pressure Vessel* another lab that was initially chosen to be in this research but was not featured in the results shown in Chapter 4. The issue encountered with the *Pressure Vessel* experiment involved a P3 firmware and software compatibility problem. The *Pressure Vessel* requires two P3 devices simultaneously gather strain readings to operate properly. The software and firmware used to transfer the readings from the device into the interface in the beginning of this research did not allow for multiple devices to be connected. A new version of software and firmware was released in early 2014 that did allow for multiple device connections. The *Pressure Vessel* interface was developed knowing that new software and firmware would be coming out and the interface could converted but due to the late release, there was not adequate time to make these adjustments. Additionally, an ActiveX guide for the new firmware was not provided as was the case for the previous firmware version that the majority of this research is based on. Consequently, the *Pressure Vessel* also had to be scratched from the list of experiments included in the student surveys.

5.3.3 Google API

When the goals of this research were being defined, one of them was to have the data being shared by Google Drive automatically rather than using Google Drive Desktop, which is a folder on the PC that sync with Drive. However, trying to implement Google API into the interfaces to automate this sharing proved to be more difficult than originally anticipated. This was mostly due to the fact that Google API is not straight forward especially for relatively new programmers. The Google functions were not difficult to find but applying them to Visual Basic proved too difficult of a task to accomplish in the given time-frame. This is hopefully something that will be completed in the next phase of this research.

5.3.4 USB Connection

The connection between the P3 Strain Indicator and Recorder and the PC being used was unstable. This was a problem for all of the interfaces and as a result an error detection segment had to be added to the code so the interface could recognize the lack of a connection, close the interface, and instruct the user to unplug and reinsert the USB cable into the P3. The USB would stay “connected” for a certain number of trials but the number of trails varied; sometimes it would work for multiple trials and sometimes only one. This creates a problem because the students would be running the interface while it was not in Visual Basic so it would not be possible just “Stop Debugging”, the interface would just crash without the error detection code. It was never determined whether the cause of this problem was the USB cable itself or the P3 device but it was one obstacle that was not able to be overcome.

5.4 Future Works

As it can be seen from the previous section, there is room for improvements and additions to this research. Some of these are simple and some are rather complicated. The plan is leave the research in a position such that the person continuing can start where this phase left off without having to spend much time understanding what has already been completed. The research has the potential to bring something new and exciting to the Mechanical and Aerospace Engineering Department at WVU: a remote laboratory utilizing cloud technology with a connection to social media.

5.4.1 Quantitative Results

Quantitative results are necessary to draw any definitive conclusions; thus far, only qualitative results have been obtained. The qualitative results are good for checking that things are moving in the proper direction but hard data is needed to solidify this research. The need for quantitative data was mentioned in the first section of this chapter to definitively determine if the lab is actually faster with the interfaces, if the reports can be done more efficiently with the students being given the data in Excel, and if the learning outcomes are truly improved.

Quantitative data was not obtained to see if the interface decreases the time necessary to perform the lab due to time constraints and limited participation. To obtain quantitative data requires a time comparison study. This was not done in this phase because there were not enough willing participants to gather any meaningful data and the time-frame to complete the

research was extremely narrow. This study would consist of timing a group of students as they perform the lab using the traditional method and then time the same group performing the same lab but using the interface method. Given enough groups of students, a definitive decision could be made as to whether the interface is faster than the traditional method in the lab.

When comparing the lab report writing process for each method, it is a matter of what format the students receive the data. In the traditional method, they generally have a paper chart that they have filled in with values and then they have to enter it into Excel before they can begin analyzing the data and writing their report. With the interface, the students are given the data in an Excel spreadsheet and can immediately start analyzing and writing. This would be much harder to conduct a controlled study because most students do not write the report in one sitting and the students would be responsible for tracking the time spent. It may also be difficult to find participants willing to perform and write reports for the same lab twice only varying the method used to obtain the data slightly. However, if possible, it would provide valuable information with regards to how beneficial the interfaces could be if implemented into the laboratory.

To test if the learning outcomes were improved would require an evaluation of the students' understanding of the concepts related to each experiment that uses an interface. At this time, the students are evaluated based on their laboratory reports and a few quizzes. An independent exam would have to be created and conducted using two groups of students, each using a different method. There would still be some variability in these results because the cognitive ability of each student is different and students learn in different ways. The graphical displays were included to positively influence the learning outcomes and it would be beneficial to have numerical results to support this statement.

5.4.2 Administrator Survey

The instructors' and teaching assistants' thoughts and opinion on the interfaces are extremely important. The opinions of these administrators should definitely be considered before implementing the interfaces into the MAE 244 course. This perspective is possibly more important than the students for the sole fact that students only have to go through the lab one time while the instructors and teaching assistants have to administer the labs multiple times. Therefore, it would only make sense that the interfaces are approved by these people since they will have at least some additional work to do to get the data to the students. The amount of extra work would, idealistically, be minimized.

5.4.3 Administrator Interface

The instructor or teaching assistant currently has to use the interfaces provide by Google to manage the files and sharing options. It would be preferable to have a developed administrative interface that would allow these things to be controlled all in one location. The interface should be designed such that the user has quick access to the email address of all of the students and can select which files to share with whom with only a few clicks. There is not much point in streamlining the students' end of the process only to bog down the instructors'.

5.4.4 Cloud Automation

The current procedure for utilizing the cloud is not exactly how it was originally intended. Presently, the data will be saved to whichever location is selected; one option is Google Drive Desktop. If Drive Desktop is selected the TA has only to go to their Google Drive account and set the sharing options for each group's folder such that only the members of each group receive their data and post on their Plus pages. If Drive Desktop is not selected then the TA has to manually upload the files to his account. While this only requires the teaching assistant to do a little extra work than normal, it is not ideal. Preferably, when the data is saved from the interfaces, it would be automatically sent to Google Drive and shared with each member of the group and post would be created on each students' Google Plus page saying that they had just completed an experiment.

5.4.5 Interface Improvements

The student participants suggested making a few changes to the interfaces that were tested. The main suggestion was the ability to correct a mistake in data entry or to "redo" the test. The experiment that the students recommended adding a "redo" button to was *Beam Bending*. While a new button was not added, the interface code was revised such that students now have the ability to overwrite data that is incorrect or essentially to undo the mistake. The revised code also helps guide the students through the experiment in such a way that the possibility of an error is greatly reduced. Some small modifications may still be required but, for the most part, the interfaces are complete.

5.5 Overall Summary

Distance learning certainly is not new and does not seem to be going away anytime soon. As a result, many institutions are creating distance learning programs so they can stay competitive. A lot of research has been, especially in the last few decades, on remote and virtual laboratories which are essential for programs that have lab requirements. Many successful remote and virtual laboratories have already been created and with technology improving as it is, many more, more extensive laboratories will be generated in the future.

This research was the first phase of a unique and creative ultimate goal: create a remote laboratory with cloud applications and the integration of social media. Since distance learning has become such an integral part of the academic sector, it only makes sense that WVU should spend resources on creating state-of-the-art distance learning programs in order for them to stay competitive. For the engineering department, this means developing remote laboratory to maintain the integrity of the engineering curriculum. The interfaces were developed with this end in mind. As mentioned in several previous sections and chapters, the interfaces were designed to be easy to use, increase efficiency in the lab and writing the reports, improved accessibility to data outside of the lab, and enhance learning outcomes. Although not all of the initial goals were accomplished, the research, overall, was successful because a stepping stone was created towards the ultimate goal of a remote laboratory at The College of Engineering and Mineral Resources at WVU.

Bibliography

- [1] D. Z. Deniz *et al*, “A Novel Approach to Remote Laboratories”, in *33rd ASEE/IEEE Frontiers in Education Conference*, Boulder, CO, November 5-8, 2003.
- [2] R. G. Main and E. Riise, “A Study of Interaction in Distance Learning”, College of Communication California State University, Chico, CA, Rep. AL/HR-TP-1994-0037, 1994.
- [3] L. Gomes and J. Garcia-Zubia, *Advances on Remote Laboratories and e-Learning Experiences*, Bilbao, Spain: Duesto, 2007.
- [4] J.M. Galusha, “Barriers to Learning in Distance Learning”, University of Southern Mississippi, Long Beach, MS, 1998.
- [5] D. Keegan. *The Future of Learning: From eLearning to mLearning*, Hagen, Germany: FernUniversitat Hagen, Nov 2002.
- [6] J. Fischer *et al*, “Inquiry-Learning with WebLab: Undergraduate Attitudes and Experiences”, *Journal of Science Education and Technology*, Vol. 16, No. 4, pp. 337-348, Aug, 2007.
- [7] I. Gustavsson, “On Objectives of Instructional Laboratories, Individual Assessment, and Use of Collaborative Remote Laboratories”, *IEEE Transactions on Learning Technologies*, Vol. 2, No. 4, pp. 263-274, Oct – Dec 2009.
- [8] E.J. Banas and W.F. Emory, “History and Issues of Distance Learning”, *Public Administration Quarterly*, Vol. 22, No. 3, pp. 365-383, Fall 1998.
- [9] Z. Nedic *et al*, “Remote Laboratories Versus Real Laboratories and Real Laboratories” in *33rd ASEE/IEEE Frontiers in Education Conference*, Boulder, CO, November 5-8, 2003.
- [10] C. Gravier *et al*, “State of the Art about Remote Laboratories Paradigms – Foundations of Ongoing Mutations”, *International Journal of Online Engineering*, Sep 2008.
- [11] L.D. Feisel and A.J. Rosa, “The Role of the Laboratory in Undergraduate Engineering Education”, *Journal of Engineering Education*, pp. 121-130, Jan, 2005.
- [12] “Total Fall Enrollment in Degree-Granting Institutions, by Attendance Status, Sex, and Age: Selected Years, 1970 through 2010.” Internet:
www.nces.ed.gov/programs/digest/d11/tables/dt11.200.asp, September 2011 [February 15, 2014].
- [13] “Distance Learning.” Internet:
https://www.google.com/search?q=define%3A+distance+learning&oq=define%3A+distance+learning&aqs=chrome..69i57j69i58.4430j0j8&&sourceid=chrome&espv=210&es_sm=93&ie=UTF-8, [February 10, 2014].
- [14] W. Osten *et al*, “Remote Laboratories for Optical Metrology: From the Lab to the Cloud”, *Optical Engineering*, Vol. 52, No. 10, October, 2013.

- [15] R. Pastor *et al*, “Laboratories as a Services (LaaS): Using Cloud Technologies in the Field of Education”, *Journal of Universal Computer Science*, Vol. 19, No. 14, pp. 2112-2126, January, 2013.
- [16] *Dynamics and Strength of Materials Laboratory Manual*, WVU MAE Department, Morgantown, WV, 2011.
- [17] *Model P3 Strain Gage Indicator and Recorder Instruction Manual*, Micro-Measurements: Division of Vishay Precision Group, Raleigh, NC, 2012.

Appendix A (Participant Cover Letter)

Dear Participant,

This letter is a request for you to take part in a research project to assess how learning efficiency of cloud based engineering lab at WVU. The purpose of this research is to study students' response for the new integrated lab environment with cloud storage and social network. This project is being conducted by Jeremy Thompson, Master student in the department of Mechanical and Aerospace Engineering at WVU with supervision of Dr. Marvin Cheng, an assistant professor in the Benjamin M. Statler College of Engineering and Mineral Resources, for a Master's Degree in Research. Your participation in this project is greatly appreciated and will take approximately 10 minutes to fill out the attached questionnaire.

Your involvement in this project will be kept as confidential as legally possible. All data will be reported in the aggregate. You must be 18 years of age or older to participate. I will not ask any information that should lead back to your identity as a participant. Your participation is completely voluntary. You may skip any question that you do not wish to answer and you may discontinue at any time. Your class standing will not be affected if you decide either not to participate or to withdraw. West Virginia University's Institutional Review Board acknowledgement of this project is on file.

I hope that you will participate in this research project, as it could be beneficial in understanding the impact of grades on student life. Thank you very much for your time. Should you have any questions about this letter or the research project, please feel free to contact Marvin Cheng at (304) 293-6732 or by e-mail at marvin.cheng@mail.wvu.edu.

Thank you for your time and help with this project.

Sincerely,



Department of Mechanical and Aerospace Engineering

Phone: 304-293-3111
Fax: 304-293-6689

PO Box 6106
Morgantown, WV 26506-6106

Equal Opportunity/Affirmative Action Institution

Appendix B (ABET Engineering Objectives)

The Fundamental Objectives of Engineering Instructional Laboratories

Objective 1: Instrumentation. Apply appropriate sensors, instrumentation, and/or software tools to make measurements of physical quantities.

Objective 2: Models. Identify the strengths and limitations of theoretical models as predictors of real-world behaviors. This may include evaluating whether a theory adequately describes a physical event and establishing or validating a relationship between measured data and underlying physical principles.

Objective 3: Experiment. Devise an experimental approach, specify appropriate equipment and procedures, implement these procedures and interpret the resulting data to characterize an engineering material, component, or system.

Objective 4: Data Analysis. Demonstrate the ability to collect, analyze, and interpret data, and to form and support conclusions. Make order of magnitude judgments and use measurement unit systems and conversions.

Objective 5: Design. Design, build, or assemble a part, product, or system, including using specific methodologies, equipment, or materials; meetings client requirements; developing system specifications from requirements; and testing and debugging a prototype, system, or process using appropriate tools to satisfy requirements.

Objective 6: Learn from Failure. Identify unsuccessful outcomes due to faulty equipment, parts, code, construction, process, or design, and then re-engineer effective solutions.

Objective 7: Creativity. Demonstrate appropriate levels of independent thought, creativity, and capability in real-world problem solving.

Objective 8: Psychomotor. Demonstrate competence in selection, modification, and operation of appropriate engineering tools and resources.

Objective 9: Safety. Identify health, safety, and environmental issues related to technological processes and activities, and deal with them responsibly.

Objective 10: Communication. Communicate effectively about laboratory work with a specific audience, both orally and in writing, at levels ranging from executive summaries to comprehensive technical reports.

Objective 11: Teamwork. Work effectively in teams, including structure individual and joint accountability; assign roles, responsibilities, and tasks; monitor progress; meet deadlines; and integrate individual contributions into a final deliverable.

Objective 12: Ethics in the Laboratory. Behave with the highest ethical standards, including reporting information objectively and interacting with integrity.

Objective 13: Sensory Awareness. Use the human senses to gather information and to make sound engineering judgments in formulating conclusions about real-world problems.

Appendix C (Lab Procedure Comparisons)

Traditional Beam Bending Procedure

1. Connect power supply to P3 Strain Indicator and Recorder.
2. Connect the longitudinal (top) and transverse (bottom) gages of the **aluminum beam** using Quarter Bridge via the P3 Strain Indicator. Follow the wire connection (color matched) instructions on the P3 Strain Indicator. Complete the bridges with an internal dummy resistor by selecting 120 Ohm internal resistors corresponding to the strain gages being used.
3. Turn on the P3 Strain Indicator.
4. Setup the P3 Strain Indicator.
5. Set the Gage Factor on the P3 Strain Indicator.
6. Balance each channel for zero output by pushing the “Balance” button on the P3 Strain Indicator.
7. Record position (deflection) of the beam on the vertical scale.
8. Load the beam to a maximum of 2.5 LBS in 0.5 LB increments. Record the strain and the vertical position of the beam tip at each load increment, as indicated by the strain indicator for each gage.
9. Repeat steps 7—10 for the composite beam.

Interface Beam Bending Procedure

1. Connect P3 Strain Indicator and Recorder to computer with the interface.
2. Open the interface
3. Connect the longitudinal (top) and transverse (bottom) gages of the **aluminum beam** using Quarter Bridge via the P3 Strain Indicator. Follow the wire connection (color matched) instructions on the P3 Strain Indicator. Complete the bridges with an internal dummy resistor by selecting 120 Ohm internal resistors corresponding to the strain gages being used.
4. Turn on the P3 Strain Indicator.
5. Setup the P3 Strain Indicator.
6. Set the Gage Factor on the Strain Indicator.
7. Balance each channel for zero output by pushing the “Balance” button on the P3 Strain Indicator.
8. Fill all text boxes in the Group Information, Dimensions, Calibrations, and Channel Select panels.
9. Set save location if it is not already set.
10. Click “Start” on the interface to initialize things and begin the experiment.
11. Apply the first load of 0.5 LB.
12. Record position (deflection) of the beam on the vertical scale and enter into appropriate text box.
13. Load the beam to a maximum of 2.5 LBS in 0.5 LB increments and select the corresponding load value from the drop-down menu on the interface.
14. Click “Save” after each load has been applied.
15. Select the “Composite” radio button and repeat steps 11 – 14 for the composite beam.
16. Click “Done” to close the interface.

Traditional Combined Loading Procedure

1. Connect power supply to P3 Strain Indicator and Recorder.
2. Connect the strain gages of the rosette on the **specimen** using Quarter Bridge via the P3 Strain Indicator. Follow the wire connection (color matched) instructions on the P3 Strain Indicator. Complete the bridges with an internal dummy resistor by selecting 120 Ohm internal resistors corresponding to the strain gages being used.
3. Turn on the P3 Strain Indicator.
4. Setup the P3 Strain Indicator.
5. Set the Gage Factor on the P3 Strain Indicator.
6. Balance each channel for zero output by pushing the “Balance” button on the P3 Strain Indicator.
7. Record the location of each rosette and the directions of all the individual gages.
8. Apply the first load based on instructions from instructor.
9. Record the strain readouts of each applied load from the P3 Strain Indicator for each gage.
10. Repeat steps 8 and 9 for as many loads as instructed.

Interface Combined Loading Procedure

1. Connect P3 Strain Indicator and Recorder to computer with the interface.
2. Open the interface
3. Connect the strain gages of the rosette on the **specimen** using Quarter Bridge via the P3 Strain Indicator. Follow the wire connection (color matched) instructions on the P3 Strain Indicator. Complete the bridges with an internal dummy resistor by selecting 120 Ohm internal resistors corresponding to the strain gages being used.
4. Turn on the P3 Strain Indicator.
5. Setup the P3 Strain Indicator.
6. Set the Gage Factor on the P3 Strain Indicator.
7. Balance each channel for zero output by pushing the “Balance” button on the P3 Strain Indicator.
8. Fill all text boxes in the Group Information, Dimensions, Calibrations, and Channel Select panels.
9. Set save location if it is not already set.
10. Click “Start” on the interface to initialize things and begin the experiment.
11. Apply the first load based on instructions from instructor.
12. Enter the load being applied into the “Applied Load” text box.
13. Click “Save” after each load has been applied.
14. Repeat steps 11—13 for as many loads as instructed.
15. Click “Done” to close the interface.

Appendix D (Research Surveys)

Development of a Remote Laboratory with Cloud Applications Research Survey

Beam Bending

The purpose of this survey is to compare traditional laboratory methods with more modern methods; more specifically, using a graphical user interface for data acquisition as opposed to pencil and paper. The following survey should be filled out honestly and portray the survey taker's opinions accurately. For each of the following questions that contain a number scale, please select the number that most accurately describes how you feel about that particular question. The numbers will range from 1 to 5, with 1 being the worst and 5 being the best, and have the following verbal associations: 1 = strongly disagree, 2 = disagree, 3 = indifferent, 4 = agree, 5 = strongly agree. The opened ended questions, those without a number scale, should be answered with a sentence(s) in your own words. Thank you for taking the time to complete this survey and making the completion of this phase of the research possible!

Number Scale Questions:

1) I prefer the interface over the traditional method.

1 2 3 4 5

2) Using the interface is detrimental to the learning outcomes.

1 2 3 4 5

3) The interface was easy to use.

1 2 3 4 5

4) The interface saved time overall.

1 2 3 4 5

5) I liked having a real-time graphical display of the deflection.

1 2 3 4 5

6) Seeing the deflection in “real-time” improved my understanding of the beam bending experiment.

1 2 3 4 5

7) Having the real-time calculations and graphical display was not helpful.

1 2 3 4 5

Open Ended Questions:

8) Describe what you liked about the interface.

9) Describe what you liked about the traditional method.

10) Describe what you disliked about the interface.

11) Describe what you disliked about the traditional method.

12) How do you think the interface affects the learning outcomes of the beam bending experiment?

13) What changes would you make to the interface?

14) How would you explain the interface to a friend?

Additional Comments or Suggestions:

Development of a Remote Laboratory with Cloud Applications Research Survey

Combined Loading

The purpose of this survey is to compare traditional laboratory methods with more modern methods; more specifically, using a graphical user interface for data acquisition as opposed to pencil and paper. The following survey should be filled out honestly and portray the survey taker's opinions accurately. For each of the following questions that contain a number scale, please select the number that most accurately describes how you feel about that particular question. The numbers will range from 1 to 5, with 1 being the worst and 5 being the best, and have the following verbal associations: 1 = strongly disagree, 2 = disagree, 3 = indifferent, 4 = agree, 5 = strongly agree. The opened ended questions, those without a number scale, should be answered with a sentence(s) in your own words. Thank you for taking the time to complete this survey and making the completion of this phase of the research possible!

Number Scale Questions:

1) I prefer the interface over the traditional method.

1 2 3 4 5

2) Using the interface is detrimental to the learning outcomes.

1 2 3 4 5

3) The interface was easy to use.

1 2 3 4 5

4) The interface saved time overall.

1 2 3 4 5

5) Seeing the comparison of the strains vs load graphically help me to understand their relationship.

1 2 3 4 5

7) Having the real-time calculations and graphical display was not helpful.

1 2 3 4 5

Open Ended Questions:

8) Describe what you liked about the interface.

9) Describe what you liked about the traditional method.

10) Describe what you disliked about the interface.

11) Describe what you disliked about the traditional method.

12) How do you think the interface affects the learning outcomes of the beam bending experiment?

13) What changes would you make to the interface?

14) How would you explain the interface to a friend?

Additional Comments or Suggestions:

Development of a Remote Laboratory with Cloud Applications Research Survey

Overall/General

The purpose of this survey is to compare traditional laboratory methods with more modern methods; more specifically, using a graphical user interface for data acquisition as opposed to pencil and paper. The following survey should be filled out honestly and portray the survey taker's opinions accurately. For each of the following questions that contain a number scale, please select the number that most accurately describes how you feel about that particular question. The numbers will range from 1 to 5, with 1 being the worst and 5 being the best, and have the following verbal associations: 1 = strongly disagree, 2 = disagree, 3 = indifferent, 4 = agree, 5= strongly agree. The opened ended questions, those without a number scale, should be answered with a sentence(s) in your own words. Thank you for taking the time to complete this survey and making the completion of this phase of the research possible!

Number Scale Questions:

1) The user interfaces helped me to understand the experiment better.

1 2 3 4 5

2) The user interfaces made data extraction easier.

1 2 3 4 5

3) Having the data already in Excel would be beneficial when writing the lab report.

1 2 3 4 5

4) Saving the results to Google Drive made it easier to access my results outside of the lab.

1 2 3 4 5

5) The user interfaces were easy to use.

1 2 3 4 5

7) The user interfaces improved the overall lab experience.

1 2 3 4 5

8) I would suggest implementing the interfaces into the MAE 244 labs.

1 2 3 4 5

9) The interfaces, as a whole, improve the learning outcomes of the selected experiments.

1 2 3 4 5

10) Not having to write anything down was favorable.

1 2 3 4 5

Open Ended Questions:

11) How would you describe your experience with the using the interfaces collectively?

12) What changes would you make?

13) What are the strengths of doing the experiment using the interfaces as compared to the traditional method?

14) What are the weaknesses of doing the experiment using the interfaces as compared to the traditional method?

15) How do you think the interfaces affect the learning outcomes of the selected experiments collectively?

Additional Comments or Suggestions:

Appendix E (Source Codes)

Beam Bending

```
Option Infer Off
Option Explicit On
Imports Microsoft.Office.Interop.Excel
Imports System
Imports System.IO
Imports System.Threading
Imports System.ComponentModel

Public Class BeamBending
    Private oChart As Chart
    Private oSerCol As SeriesCollection
    Private oDeflection, oLoadnum As Axes
    Private oSeriesAL, oSeriesComp As Series
    Private RngAL, RngComp, RngLoad As Range
    Private savefile As System.IO.StreamWriter
    Private oExcel, oBook, oSheet, P3, aldeflectref, compdeflectref As Object
    Private emcount, savemsg, replacemsg, skipsavemsg, charcount, h, appcloseflag, bookcloseflag As Integer
    Private blenC, bthickC, bcenterC, bwidthC As Double
    Private gfact, gresist, blenA, bthickA, bcenterA, bwidthA, appload, aldeflection, compdeflection, deflectposition As
Double
    Private selectedsavelocation, readsavelocation, savelocation, inmessage, intitle As String
    Private daytime, section, groupnum, email(), foldername, fname, strText(), hstring As String
    Private savedate, savedatetime, savetime, oHour, oMinute, oSecond, savedirect, slocation, cdrive As String

    Private Sub BeamBending_Load(ByVal sender As System.Object, ByVal e As System.EventArgs) Handles
MyBase.Load
        **Open Excel and Create Worksheet**
        oExcel = CreateObject("Excel.Application")
        oBook = oExcel.Workbooks.Add
        oSheet = oBook.Worksheets(1)
        oExcel.Visible = False
        oExcel.DisplayAlerts = False

        **Finds previous file save location .txt file, if none is found then user must select a location**
        If (Not Directory.Exists("C:\Save Directory\Beam Bending")) Then
            Directory.CreateDirectory("C:\Save Directory\Beam Bending")
            If FolderBrowserDialog1.ShowDialog() = DialogResult.OK Then
                selectedsavelocation = FolderBrowserDialog1.SelectedPath
            End If
            savefile = My.Computer.FileSystem.OpenTextFileWriter("C:\Save Directory\Beam Bending\savedirectory.txt",
True)
            savefile.WriteLine(selectedsavelocation)
            savefile.Close()
            TextBox11.Text = selectedsavelocation
        ElseIf (Directory.Exists("C:\Save Directory\Beam Bending")) Then
            If My.Computer.FileSystem.FileExists("C:\Save Directory\Beam Bending\savedirectory.txt") = True Then
                readsavelocation = My.Computer.FileSystem.ReadAllText("C:\Save Directory\Beam
Bending\savedirectory.txt")
                TextBox11.Text = readsavelocation
            ElseIf My.Computer.FileSystem.FileExists("C:\Save Directory\Beam Bending\savedirectory.txt") = False Then
                If FolderBrowserDialog1.ShowDialog() = DialogResult.OK Then
                    selectedsavelocation = FolderBrowserDialog1.SelectedPath
                End If
            End If
        End If
    End Sub
End Class
```

```

savefile = My.Computer.FileSystem.OpenTextFileWriter("C:\Save Directory\Beam Bending\savedirectory.txt",
True)
savefile.WriteLine(selectedsavelocation)
savefile.Flush()
savefile.Close()
End If
End If

***Reads save location .txt file and creates that path to save data**
readsavelocation = My.Computer.FileSystem.ReadAllText("C:\Save Directory\Beam Bending\savedirectory.txt")
savelocation = readsavelocation.Trim()
TextBox11.Text = savelocation

***Establishes real-time chart size**
Chart1.ChartAreas("ChartArea1").AxisX.Minimum = 0
Chart1.ChartAreas("ChartArea1").AxisX.Maximum = 5
Chart1.ChartAreas("ChartArea1").AxisX.Interval = 1
Chart1.ChartAreas("ChartArea1").AxisY.Minimum = -1
Chart1.ChartAreas("ChartArea1").AxisY.Maximum = 0
Chart1.Series("Aluminum").Points.AddXY(0.0, 0.0)
Chart1.Series("Composite").Points.AddXY(0.0, 0.0)

***set flag values for later use**
bookcloseflag = 0
appcloseflag = 0
End Sub
Private Sub startbutton_Click(ByVal sender As System.Object, ByVal e As System.EventArgs) Handles
startbutton.Click
***Create P3 Object and Open Device**
P3 = CreateObject("VMMP3Control.VMMP3Controller")
On Error GoTo Line1
P3.DeviceOpen = True

***Set up chart in Excel and save information for file**
oChart = oSheet.shapes.AddChart.Chart
oSerCol = oChart.SeriesCollection
oSeriesAL = oSerCol.NewSeries
oSeriesComp = oSerCol.NewSeries
savedate = Format(Now, "MMM-dd-yyyy")
savedatetime = DateTime.Now
oHour = Hour(savedatetime).ToString()
oMinute = Minute(savedatetime).ToString()
oSecond = Second(savedatetime).ToString()
savetime = oHour & "-" & oMinute & "-" & oSecond
section = TextBox1.Text
groupnum = TextBox2.Text
'strText = Split(TextBox3.Text, vbCrLf)
'emcount = TextBox3.Lines.Count()

***Check for directory with same section/group info, if none exist then create one**
foldername = ("Section " & section & " - Group " & groupnum)
If (Not Directory.Exists(savelocation & "\" & foldername)) Then
Directory.CreateDirectory(savelocation & "\" & foldername)
End If
fname = ("Beam Bending - " & savedate & " " & savetime)

***add values to variables from interface**
gfact = TextBox4.Text

```

```

gresist = TextBox5.Text
blenA = TextBox6.Text
bthickA = TextBox7.Text
bcenterA = TextBox8.Text
bwidthA = TextBox9.Text
blenC = TextBox14.Text
bthickC = TextBox13.Text
bcenterC = TextBox12.Text
bwidthC = TextBox3.Text

```

****Place initial info and parameters in Excel****

```

With oSheet
    .Cells(1, 1) = "Date:"
    .Cells(1, 2) = Format(Now, "MMM-dd-yyyy")
    .Cells(2, 1) = "Section #:"
    .Cells(2, 2) = section
    .Cells(3, 1) = "Group #:"
    .Cells(3, 2) = groupnum
    .Cells(4, 1) = "Emails:"
    .Range(oSheet.Cells(4, 1), oSheet.Cells(4, 2)).Merge()
    .Cells(5, 1) = "Calibration Factors"
    .Range(oSheet.Cells(5, 1), oSheet.Cells(5, 2)).Merge()
    .Cells(6, 1) = "Gage Factor ="
    .Cells(6, 2) = gfact
    .Cells(7, 1) = "Gage Resistance ="
    .Cells(7, 2) = gresist
    .Cells(9, 1) = "Dimensions - Aluminum"
    .Range(oSheet.Cells(9, 1), oSheet.Cells(9, 2)).Merge()
    .Cells(10, 1) = "Length ="
    .Cells(10, 2) = blenA
    .Cells(11, 1) = "Thickness ="
    .Cells(11, 2) = bthickA
    .Cells(12, 1) = "End to Center ="
    .Cells(12, 2) = bcenterA
    .Cells(13, 1) = "Width ="
    .Cells(13, 2) = bwidthA
    .Cells(15, 1) = "Dimensions - Composite"
    .Range(oSheet.Cells(15, 1), oSheet.Cells(15, 2)).Merge()
    .Cells(16, 1) = "Length ="
    .Cells(16, 2) = blenC
    .Cells(17, 1) = "Thickness ="
    .Cells(17, 2) = bthickC
    .Cells(18, 1) = "End to Center ="
    .Cells(18, 2) = bcenterC
    .Cells(19, 1) = "Width ="
    .Cells(19, 2) = bwidthC
    .Cells(8, 5) = "Strain"
    .Range(oSheet.Cells(8, 5), oSheet.Cells(8, 10)).Merge()
    .Cells(1, 4) = "Aluminum (Strain in micro-strain)"
    .Range(oSheet.Cells(1, 4), oSheet.Cells(1, 7)).Merge()
    .Cells(9, 4) = "Composite (Strain in micro-strain)"
    .Range(oSheet.Cells(9, 4), oSheet.Cells(9, 7)).Merge()
    .Cells(2, 4) = "Load (lbs)"
    .Cells(2, 5) = "Axial"
    .Cells(2, 6) = "Transverse"
    .Cells(2, 7) = "Deflection"
    .Cells(10, 4) = "Load (lbs)"
    .Cells(10, 5) = "Axial"
    .Cells(10, 6) = "Transverse"

```



```

.Cells(10, 7) = "Deflection"
.Cells(3, 4) = "0.5"
.Cells(4, 4) = "1.0"
.Cells(5, 4) = "1.5"
.Cells(6, 4) = "2.0"
.Cells(7, 4) = "2.5"
.Cells(11, 4) = "0.5"
.Cells(12, 4) = "1.0"
.Cells(13, 4) = "1.5"
.Cells(14, 4) = "2.0"
.Cells(15, 4) = "2.5"
End With

**Section to add emails for the group if desired**
Dim j As Integer = 0
While j < emcount
With oSheet
.Cells(j + 5, 1) = strText(j)
.Range(oSheet.Cells(j + 5, 1), oSheet.Cells(j + 5, 2)).Merge()

End With
j = j + 1
End While

**Shows current readings from P3 in labels**
Label15.Text = P3.CurrentReading(ComboBox1.SelectedIndex + 2)
Label17.Text = P3.CurrentReading(ComboBox2.SelectedIndex + 2)
Label19.Text = P3.CurrentReading(ComboBox3.SelectedIndex + 2)
Label21.Text = P3.CurrentReading(ComboBox4.SelectedIndex + 2)

**Dummy values for labels to test when out of lab**
Label15.Text = ComboBox1.SelectedIndex
Label17.Text = ComboBox2.SelectedIndex
Label19.Text = ComboBox3.SelectedIndex
Label21.Text = ComboBox4.SelectedIndex

**PopUp Input Box for the "zero" deflection point. This allows the user to input the following readings**
inmessage = "Enter the 'zero deflection' value for Aluminum."
intitle = "Zero Deflection Input"
aldeflectref = InputBox(inmessage, intitle)

**Flag for showing that the program has been started**
appcloseflag = 1

**If P3 cannot be accessed, the from is closed and the user is asked to reconnect the P3**
Line1: If Err.Number <> 0 Then
oBook.Close()
oExcel.DisplayAlerts = True
oExcel.quit()
Me.Close()
Else
End If
End Sub
Private Sub savebutton_Click(ByVal sender As System.Object, ByVal e As System.EventArgs) Handles
savebutton.Click
**Reset skipsavemsg value for each click**
skipsavemsg = 0

```

```

***Shows current readings from P3 in labels (+2 is because of new firmware)**
Label15.Text = P3.CurrentReading(ComboBox1.SelectedIndex + 2)
Label17.Text = P3.CurrentReading(ComboBox2.SelectedIndex + 2)
Label19.Text = P3.CurrentReading(ComboBox3.SelectedIndex + 2)
Label21.Text = P3.CurrentReading(ComboBox4.SelectedIndex + 2)

***Dummy values for labels to test when out of lab**
'Label15.Text = ComboBox1.SelectedIndex * (ProgressBar1.Value + 1)
'Label17.Text = ComboBox2.SelectedIndex * (ProgressBar1.Value + 1)
'Label19.Text = ComboBox3.SelectedIndex * (ProgressBar1.Value + 1)
'Label21.Text = ComboBox4.SelectedIndex * (ProgressBar1.Value + 1)

***Determine the deflection based on user input**
deflectposition = TextBox10.Text
aldeflection = Math.Abs(aldeflectref - deflectposition)
compdeflection = Math.Abs(compdeflectref - deflectposition)

***Selecting material and adding strain values and deflections to Excel**
***Each load for both materials runs through the same operations**
***First it checks to see if the Excel cells associated with that load are empty
***If they are then it fills them in with the new data--otherwise, it will ask if the user wants to overwrite the previous data with the new
***If yes, the previous data point is removed and the new is added to the graphical display
***If no, the program disregards the new data
***For both cases, the progress bar accounts for the "redo"***
***Aluminum**
If RadioButton1.Checked = True Then
    If ComboBox5.SelectedIndex = 0 Then
        If oSheet.Cells(3, 5).Value Is Nothing Then
            Else
                skipsavemsg = MsgBox("This load for this material has already been completed, would you like to continue saving?", vbYesNo + vbQuestion, "Save Overwrite")
            End If
            If skipsavemsg = 7 Then
                ProgressBar1.Value = ProgressBar1.Value - 1
            ElseIf skipsavemsg = 6 Then
                ProgressBar1.Value = ProgressBar1.Value - 1
                Chart1.Series("Aluminum").Points.RemoveAt(1)
                With oSheet
                    .Cells(3, 5) = Label15.Text
                    .Cells(3, 6) = Label17.Text
                    .Cells(3, 7) = -aldeflection
                End With
            Else
                With oSheet
                    .Cells(3, 5) = Label15.Text
                    .Cells(3, 6) = Label17.Text
                    .Cells(3, 7) = -aldeflection
                End With
            End If
        ElseIf ComboBox5.SelectedIndex = 1 Then
            If oSheet.Cells(4, 5).Value Is Nothing Then
                Else
                    skipsavemsg = MsgBox("This load for this material has already been completed, would you like to continue saving?", vbYesNo + vbQuestion, "Save Overwrite")
                End If
                If skipsavemsg = 7 Then
                    ProgressBar1.Value = ProgressBar1.Value - 1
                ElseIf skipsavemsg = 6 Then

```

```

ProgressBar1.Value = ProgressBar1.Value - 1
Chart1.Series("Aluminum").Points.RemoveAt(2)
With oSheet
    .Cells(4, 5) = Label15.Text
    .Cells(4, 6) = Label17.Text
    .Cells(4, 7) = -aldeflection
End With
Else
    With oSheet
        .Cells(4, 5) = Label15.Text
        .Cells(4, 6) = Label17.Text
        .Cells(4, 7) = -aldeflection
    End With
End If
ElseIf ComboBox5.SelectedIndex = 2 Then
    If oSheet.Cells(5, 5).Value Is Nothing Then
        Else
            skipsavemsg = MsgBox("This load for this material has already been completed, would you like to continue
saving?", vbYesNo + vbQuestion, "Save Overwrite")
        End If
        If skipsavemsg = 7 Then
            ProgressBar1.Value = ProgressBar1.Value - 1
        ElseIf skipsavemsg = 6 Then
            ProgressBar1.Value = ProgressBar1.Value - 1
            Chart1.Series("Aluminum").Points.RemoveAt(3)
            With oSheet
                .Cells(5, 5) = Label15.Text
                .Cells(5, 6) = Label17.Text
                .Cells(5, 7) = -aldeflection
            End With
        Else
            With oSheet
                .Cells(5, 5) = Label15.Text
                .Cells(5, 6) = Label17.Text
                .Cells(5, 7) = -aldeflection
            End With
        End If
    ElseIf ComboBox5.SelectedIndex = 3 Then
        If oSheet.Cells(6, 5).Value Is Nothing Then
            Else
                skipsavemsg = MsgBox("This load for this material has already been completed, would you like to continue
saving?", vbYesNo + vbQuestion, "Save Overwrite")
            End If
            If skipsavemsg = 7 Then
                ProgressBar1.Value = ProgressBar1.Value - 1
            ElseIf skipsavemsg = 6 Then
                ProgressBar1.Value = ProgressBar1.Value - 1
                Chart1.Series("Aluminum").Points.RemoveAt(4)
                With oSheet
                    .Cells(6, 5) = Label15.Text
                    .Cells(6, 6) = Label17.Text
                    .Cells(6, 7) = -aldeflection
                End With
            Else
                With oSheet
                    .Cells(6, 5) = Label15.Text
                    .Cells(6, 6) = Label17.Text
                    .Cells(6, 7) = -aldeflection
                End With
            End If
        End If
    End If
End If

```

```

End If
ElseIf ComboBox5.SelectedIndex = 4 Then
  If oSheet.Cells(7, 5).Value Is Nothing Then
  Else
    skipsavemsg = MsgBox("This load for this material has already been completed, would you like to continue
saving?", vbYesNo + vbQuestion, "Save Overwrite")
  End If
  If skipsavemsg = 7 Then
    ProgressBar1.Value = ProgressBar1.Value - 1
  ElseIf skipsavemsg = 6 Then
    ProgressBar1.Value = ProgressBar1.Value - 1
    Chart1.Series("Aluminum").Points.RemoveAt(5)
    With oSheet
      .Cells(7, 5) = Label15.Text
      .Cells(7, 6) = Label17.Text
      .Cells(7, 7) = -aldeflection
    End With
  Else
    With oSheet
      .Cells(7, 5) = Label15.Text
      .Cells(7, 6) = Label17.Text
      .Cells(7, 7) = -aldeflection
    End With
  End If
End If
End If
**Add deflections to real-time graph on interface for aluminum**
Chart1.Series("Aluminum").Points.AddXY(ComboBox5.SelectedIndex + 1, -aldeflection)
Chart1.Series("Aluminum").ChartArea = "ChartArea1"

**Composite**
ElseIf RadioButton2.Checked = True Then
  If ComboBox5.SelectedIndex = 0 Then
  If oSheet.Cells(11, 5).Value Is Nothing Then
  Else
    skipsavemsg = MsgBox("This load for this material has already been completed, would you like to continue
saving?", vbYesNo + vbQuestion, "Save Overwrite")
  End If
  If skipsavemsg = 7 Then
    ProgressBar1.Value = ProgressBar1.Value - 1
  ElseIf skipsavemsg = 6 Then
    ProgressBar1.Value = ProgressBar1.Value - 1
    Chart1.Series("Composite").Points.RemoveAt(1)
    With oSheet
      .Cells(11, 5) = Label19.Text
      .Cells(11, 6) = Label21.Text
      .Cells(11, 7) = -compdeflection
    End With
  Else
    With oSheet
      .Cells(11, 5) = Label19.Text
      .Cells(11, 6) = Label21.Text
      .Cells(11, 7) = -compdeflection
    End With
  End If
ElseIf ComboBox5.SelectedIndex = 1 Then
  If oSheet.Cells(12, 5).Value Is Nothing Then
  Else

```

```

        skipsavemsg = MsgBox("This load for this material has already been completed, would you like to continue
saving?", vbYesNo + vbQuestion, "Save Overwrite")
    End If
    If skipsavemsg = 7 Then
        ProgressBar1.Value = ProgressBar1.Value - 1
    ElseIf skipsavemsg = 6 Then
        ProgressBar1.Value = ProgressBar1.Value - 1
        Chart1.Series("Composite").Points.RemoveAt(2)
        With oSheet
            .Cells(12, 5) = Label19.Text
            .Cells(12, 6) = Label21.Text
            .Cells(12, 7) = -compdeflection
        End With
    Else
        With oSheet
            .Cells(12, 5) = Label19.Text
            .Cells(12, 6) = Label21.Text
            .Cells(12, 7) = -compdeflection
        End With
    End If
    ElseIf ComboBox5.SelectedIndex = 2 Then
        If oSheet.Cells(13, 5).Value Is Nothing Then
            Else
                skipsavemsg = MsgBox("This load for this material has already been completed, would you like to continue
saving?", vbYesNo + vbQuestion, "Save Overwrite")
            End If
            If skipsavemsg = 7 Then
                ProgressBar1.Value = ProgressBar1.Value - 1
            ElseIf skipsavemsg = 6 Then
                ProgressBar1.Value = ProgressBar1.Value - 1
                Chart1.Series("Composite").Points.RemoveAt(3)
                With oSheet
                    .Cells(13, 5) = Label19.Text
                    .Cells(13, 6) = Label21.Text
                    .Cells(13, 7) = -compdeflection
                End With
            Else
                With oSheet
                    .Cells(13, 5) = Label19.Text
                    .Cells(13, 6) = Label21.Text
                    .Cells(13, 7) = -compdeflection
                End With
            End If
        ElseIf ComboBox5.SelectedIndex = 3 Then
            If oSheet.Cells(14, 5).Value Is Nothing Then
                Else
                    skipsavemsg = MsgBox("This load for this material has already been completed, would you like to continue
saving?", vbYesNo + vbQuestion, "Save Overwrite")
                End If
                If skipsavemsg = 7 Then
                    ProgressBar1.Value = ProgressBar1.Value - 1
                ElseIf skipsavemsg = 6 Then
                    ProgressBar1.Value = ProgressBar1.Value - 1
                    Chart1.Series("Composite").Points.RemoveAt(4)
                    With oSheet
                        .Cells(14, 5) = Label19.Text
                        .Cells(14, 6) = Label21.Text
                        .Cells(14, 7) = -compdeflection
                    End With
                End If
            End If
        End If
    End If

```

```

Else
    With oSheet
        .Cells(14, 5) = Label19.Text
        .Cells(14, 6) = Label21.Text
        .Cells(14, 7) = -compdeflection
    End With
End If
ElseIf ComboBox5.SelectedIndex = 4 Then
    If oSheet.Cells(15, 5).Value Is Nothing Then
        Else
            skipsavemsg = MsgBox("This load for this material has already been completed, would you like to continue saving?", vbYesNo + vbQuestion, "Save Overwrite")
        End If
        If skipsavemsg = 7 Then
            ProgressBar1.Value = ProgressBar1.Value - 1
        ElseIf skipsavemsg = 6 Then
            ProgressBar1.Value = ProgressBar1.Value - 1
            Chart1.Series("Composite").Points.RemoveAt(5)
            With oSheet
                .Cells(15, 5) = Label19.Text
                .Cells(15, 6) = Label21.Text
                .Cells(15, 7) = -compdeflection
            End With
        Else
            With oSheet
                .Cells(15, 5) = Label19.Text
                .Cells(15, 6) = Label21.Text
                .Cells(15, 7) = -compdeflection
            End With
        End If
    End If
    **Add deflections to real-time graph on interface for composite**
    Chart1.Series("Composite").Points.AddXY(ComboBox5.SelectedIndex + 1, -compdeflection)
    Chart1.Series("Composite").ChartArea = "ChartArea1"
End If

**Increase progress bar by 1 per load**
ProgressBar1.Value = ProgressBar1.Value + 1

**Instructs the students to which to composite and reset the load as well as enter the "zero" composite position on the ruler**
If RadioButton1.Checked And ComboBox5.SelectedIndex = 4 Then
    MsgBox.Show("All loads for Aluminum have been completed")
    Thread.Sleep(1000)
    inmessage = "Enter the 'zero deflection' value for Composite."
    intitle = "Zero Deflection Input"
    compdeflectref = InputBox(inmessage, intitle)
    MsgBox.Show("Select the Composite Radio Button and Reset Applied Load to 0.5")
End If

**Instructions for program after progress bar has been filled**
If ProgressBar1.Value = 10 Then

    **Create ranges for Excel Chart**
    RngAL = oSheet.Range(oSheet.Cells(3, 7), oSheet.Cells(7, 7))
    RngComp = oSheet.Range(oSheet.Cells(11, 7), oSheet.Cells(15, 7))
    RngLoad = oSheet.Range(oSheet.Cells(11, 4), oSheet.Cells(15, 4))

    **Set-up Excel Chart and add ranges from data**

```

```

With oChart
    .ChartType = XlChartType.xlLine
    **Create Title**
    .HasTitle = True
    .ChartTitle.Text = "Beam Bending Deflection"
    **Create Axes**
    oLoadnum = CType(oChart.Axes(, XlAxisGroup.xlPrimary), Axes)
    oLoadnum.Item(XlAxisType.xlCategory).HasTitle = True
    oLoadnum.Item(XlAxisType.xlCategory).AxisTitle.Characters.Text = "Load"
    oDeflection = CType(oChart.Axes(, XlAxisGroup.xlPrimary), Axes)
    oDeflection.Item(XlAxisType.xlValue).HasTitle = True
    oDeflection.Item(XlAxisType.xlValue).AxisTitle.Characters.Text = "Deflection"
    **Create Legend**
    .HasLegend = True
    .SeriesCollection(1).name = "Aluminum"
    .SeriesCollection(2).name = "Composite"
    **Supply X and Y Values**
    With oSeriesAL
        .XValues = RngLoad
        .Values = RngAL
    End With
    With oSeriesComp
        .XValues = RngLoad
        .Values = RngComp
    End With
    **Set Chart Size and Position**
    .ChartArea.Height = 300
    .ChartArea.Width = 305
    .ChartArea.Top = 296
    .ChartArea.Left = 65
End With

**Format Excel Sheet**
With oSheet
    .Columns("A").ColumnWidth = 15
    .Columns("B").ColumnWidth = 12
    .Columns("D").ColumnWidth = 10
    .Columns("E").ColumnWidth = 10
    .Columns("F").ColumnWidth = 10
    .Columns("G").ColumnWidth = 10
    .Columns("A:G").HorizontalAlignment = -4108
End With

**Notifies user that they are done**
    MessageBox.Show("All Done! Click End to Save and Exit")
End If
End Sub
Private Sub donebutton_Click(ByVal sender As System.Object, ByVal e As System.EventArgs) Handles
donebutton.Click
    **Flag for showing that the "end" button has been clicked**
    appcloseflag = 2

    **Save file to folder as long as it exists, replace if file already exists**
    **oBook.Close() closes the Excel book but not Excel**
    If foldername Is Nothing Then
    ElseIf oSheet.Cells(15, 5).Value Is Nothing Or oSheet.Cells(7, 5) Is Nothing Then
        oBook.Close()
    Else
        If My.Computer.FileSystem.FileExists(savelocation & "\" & foldername & "\" & fname & ".xlsx") = False Then

```

```

        oBook.SaveAs(savelocation & "\" & foldername & "\" & fname & ".xlsx")
        oBook.Close()
    ElseIf My.Computer.FileSystem.FileExists(savelocation & "\" & foldername & "\" & fname & ".xlsx") = True
Then
        replacemsg = MsgBox("This file already exists, would you like to overwrite with the current file?", vbYesNo +
vbQuestion, "Replace Alert")
        If replacemsg = 6 Then
            oBook.SaveAs(savelocation & "\" & foldername & "\" & fname & ".xlsx")
            oBook.Close()
        ElseIf replacemsg = 7 Then
            oBook.Close()
        End If
    End If
End If
End If
**Turns Alerts back on, closes Excel and interface form**
oExcel.DisplayAlerts = True
oExcel.Quit()
Me.Close()
End Sub
Private Sub Button4_Click(ByVal sender As System.Object, ByVal e As System.EventArgs) Handles
changedirectory.Click
    **button to change where to results**
    **browse computer for new location**
    System.IO.File.WriteAllText("C:\Save Directory\Beam Bending\savedirectory.txt", "")
    If FolderBrowserDialog1.ShowDialog() = DialogResult.OK Then
        selectedsavelocation = FolderBrowserDialog1.SelectedPath
    End If
    savefile = My.Computer.FileSystem.OpenTextFileWriter("C:\Save Directory\Beam Bending\savedirectory.txt",
True)
    savefile.WriteLine(selectedsavelocation)
    savefile.Close()

    **read .txt file that contains new save location**
    readsavelocation = My.Computer.FileSystem.ReadAllText("C:\Save Directory\Beam Bending\savedirectory.txt")
    savelocation = readsavelocation.Trim()
    TextBox11.Text = savelocation
End Sub
Private Sub BeamBending_FormClosing(ByVal sender As System.Object, ByVal e As
System.Windows.Forms.FormClosingEventArgs) Handles MyBase.FormClosing
    If appcloseflag = 1 Then
        **Close P3 device**
        P3.DeviceOpen = False
    End If

    **double check that everything has been closed and save alerts in Excel have been turned back on**
    If appcloseflag = 2 Then
    ElseIf appcloseflag = 0 Or appcloseflag = 1 Then
        If Err.Number = 0 Then
            oBook.Close()
        End If
        oExcel.DisplayAlerts = True
        oExcel.Quit()
    End If

    **message for user if P3 device was not connect properly**
    If Err.Number <> 0 Then
        MessageBox.Show("Please Reconnect P3 and Start Again")
    Else
    End If
End If

```

End Sub
End Class

Combined Loading

```
Option Infer Off
Option Explicit On
Imports Microsoft.Office.Interop.Excel
Imports System
Imports System.IO
Imports System.Threading
Imports System.ComponentModel

Public Class CombinedLoading
    Private oChart As Chart
    Private oStrain, oLoadnum As Axes
    Private oSerCol As SeriesCollection
    Private oStrA, oStrB, oStrC As Series
    Private RngA, RngB, RngC, RngLoad As Range
    Private savefile As System.IO.StreamWriter
    Private oExcel, oBook, oSheet, P3, loadcount As Object
    Private gfact, gresist, armtogage, momentarm As Double
    Private strainA, strainB, strainC, shaftd, appload As Double
    Private savemsg, replacemsg, emcount, bookcloseflag, appcloseflag, i As Integer
    Private selectedsavelocation, readsavelocation, savelocation As String
    Private savedate, savedatetime, savetime, oHour, oMinute, oSecond As String
    Private daytime, section, groupnum, email(), foldername, fname, strText() As String

    Private Sub CombinedLoading_Load(ByVal sender As System.Object, ByVal e As System.EventArgs) Handles MyBase.Load
        Open Excel and Create Worksheet
        oExcel = CreateObject("Excel.Application")
        oBook = oExcel.Workbooks.Add
        oSheet = oBook.Worksheets(1)
        oExcel.Visible = False
        oExcel.DisplayAlerts = False

        Finds previous file save location .txt file, if none is found then user must select a location
        If (Not Directory.Exists("C:\Save Directory\Combined Loading")) Then
            Directory.CreateDirectory("C:\Save Directory\Combined Loading")
            If FolderBrowserDialog1.ShowDialog() = DialogResult.OK Then
                selectedsavelocation = FolderBrowserDialog1.SelectedPath
            End If
            savefile = My.Computer.FileSystem.OpenTextFileWriter("C:\Save Directory\Combined
Loading\savedirectory.txt", True)
            savefile.WriteLine(selectedsavelocation)
            savefile.Close()
            TextBox11.Text = selectedsavelocation
        ElseIf (Directory.Exists("C:\Save Directory\Combined Loading")) Then
            If My.Computer.FileSystem.FileExists("C:\Save Directory\Combined Loading\savedirectory.txt") = True Then
                readsavelocation = My.Computer.FileSystem.ReadAllText("C:\Save Directory\Combined
Loading\savedirectory.txt")
                TextBox11.Text = readsavelocation
            ElseIf My.Computer.FileSystem.FileExists("C:\Save Directory\Combined Loading\savedirectory.txt") = False
            Then
                If FolderBrowserDialog1.ShowDialog() = DialogResult.OK Then
                    selectedsavelocation = FolderBrowserDialog1.SelectedPath
                End If
            End If
        End Sub
    End Class
```

```

        savefile = My.Computer.FileSystem.OpenTextFileWriter("C:\Save Directory\Combined
Loading\savedirectory.txt", True)
        savefile.WriteLine(selectedsavelocation)
        savefile.Flush()
        savefile.Close()
    End If
End If

    Reads save location .txt file and creates that path to save data
    readsavelocation = My.Computer.FileSystem.ReadAllText("C:\Save Directory\Combined
Loading\savedirectory.txt")
    savelocation = readsavelocation.Trim()
    TextBox11.Text = savelocation

    Establishes real-time chart size
    Chart1.Series("Strain at A").Points.AddXY(0, 0)
    Chart1.Series("Strain at B").Points.AddXY(0, 0)
    Chart1.Series("Strain at C").Points.AddXY(0, 0)

    Set initial counter value
    i = 0
    set flag values for later use
    bookcloseflag = 0
    appcloseflag = 0
End Sub
Private Sub Button1_Click(ByVal sender As System.Object, ByVal e As System.EventArgs) Handles Button1.Click
    Create P3 Object and Open Device
    P3 = CreateObject("VMMP3Control.VMMP3Controller")
    On Error GoTo Line1
    P3.DeviceOpen = True

    Set up chart in Excel and save information for file
    oChart = oSheet.shapes.AddChart.Chart
    oSerCol = oChart.SeriesCollection
    oStrA = oSerCol.NewSeries
    oStrB = oSerCol.NewSeries
    oStrC = oSerCol.NewSeries
    savedate = Format(Now, "MMM-dd-yyyy")
    savedatetime = DateTime.Now
    oHour = Hour(savedatetime).ToString()
    oMinute = Minute(savedatetime).ToString()
    oSecond = Second(savedatetime).ToString()
    savetime = oHour & "-" & oMinute & "-" & oSecond
    section = TextBox1.Text
    groupnum = TextBox2.Text
    'strText = Split(TextBox3.Text, vbCrLf)
    'emcount = TextBox3.Lines.Count()

    Check for directory with same section/group info, if none exist then create one
    foldername = ("Section " & section & " - Group " & groupnum)
    If (Not Directory.Exists(savelocation & "\" & foldername)) Then
        Directory.CreateDirectory(savelocation & "\" & foldername)
    End If
    frame = ("Combined Loading - " & savedate & " " & savetime)

    add values to variables from interface
    gfact = TextBox4.Text
    gresist = TextBox5.Text
    armtogage = TextBox6.Text

```

```
momentarm = TextBox7.Text
shaftd = TextBox8.Text
```

```
***Place initial info and parameters in Excel**
```

```
With oSheet
```

```
.Cells(1, 1) = "Date:"
.Cells(1, 2) = Format(Now, "MMM-dd-yyyy")
.Cells(2, 1) = "Section #:"
.Cells(2, 2) = section
.Cells(3, 1) = "Group #:"
.Cells(3, 2) = groupnum
'.Cells(4, 1) = "Emails:"
'.Range(oSheet.Cells(4, 1), oSheet.Cells(4, 2)).Merge()
.Cells(5, 1) = "Calibration Factors"
.Range(oSheet.Cells(5, 1), oSheet.Cells(5, 2)).Merge()
.Cells(6, 1) = "Gage Factor ="
.Cells(6, 2) = gfact
.Cells(7, 1) = "Gage Resistance ="
.Cells(7, 2) = gresist
.Cells(9, 1) = "Dimensions of Circular Shaft"
.Range(oSheet.Cells(9, 1), oSheet.Cells(9, 2)).Merge()
.Cells(10, 1) = "Arm to Gage (Y) ="
.Cells(10, 2) = armtogage
.Cells(11, 1) = "Moment Arm (L) ="
.Cells(11, 2) = momentarm
.Cells(12, 1) = "Diameter (D) ="
.Cells(12, 2) = shaftd
.Cells(1, 5) = "Strain (in micro-strain)"
.Range(oSheet.Cells(1, 5), oSheet.Cells(1, 7)).Merge()
.Cells(2, 4) = "Applied Load"
.Cells(2, 5) = "Gage A"
.Cells(2, 6) = "Gage B"
.Cells(2, 7) = "Gage C"
```

```
End With
```

```
***Section to add emails for the group if desired**
```

```
'Dim j As Integer = 0
'While j < emcount
```

```
'With oSheet
```

```
'.Cells(j + 5, 1) = strText(j)
'.Range(oSheet.Cells(j + 5, 1), oSheet.Cells(j + 5, 2)).Merge()
'End With
'j = j + 1
'End While
```

```
***popup input box for number loads that will be applied**
```

```
loadcount = InputBox("How many loads will be applied?", "Applied Load Count")
```

```
***Shows current readings from P3 in labels**
```

```
strainA = P3.CurrentReading(ComboBox1.SelectedIndex + 2)
strainB = P3.CurrentReading(ComboBox2.SelectedIndex + 2)
strainC = P3.CurrentReading(ComboBox3.SelectedIndex + 2)
```

```
***Dummy values for labels to test when out of lab**
```

```
'strainA = 3
'strainB = 4
'strainC = 5
```

```

    '**displays strains from each location in appropriate label**
    Label14.Text = strainA
    Label16.Text = strainB
    Label18.Text = strainC

    '**Set size of char in interface based on number of loads that will be applied**
    Chart1.ChartAreas("ChartArea1").AxisX.Minimum = 0
    Chart1.ChartAreas("ChartArea1").AxisX.Maximum = 100 * loadcount
    'Chart1.ChartAreas("ChartArea1").AxisY.Minimum = 0
    'Chart1.ChartAreas("ChartArea1").AxisY.Maximum = 2

    '**Flag for showing that the program has been started**
    appcloseflag = 1

    '**If P3 cannot be accessed, the form is closed and the user is asked to reconnect the P3**
Line1: If Err.Number <> 0 Then
    oBook.Close()
    oExcel.DisplayAlerts = True
    oExcel.quit()
    Me.Close()
Else
End If
End Sub
Private Sub Button2_Click(ByVal sender As System.Object, ByVal e As System.EventArgs) Handles Button2.Click
    '**Set max value for progress bar based on user input of number of loads**
    ProgressBar1.Maximum = loadcount
    '**collects user input for load value**
    appload = TextBox10.Text

    '**Shows current readings from P3 in labels (+2 is because of new firmware)**
    strainA = P3.CurrentReading(ComboBox1.SelectedIndex + 2)
    strainB = P3.CurrentReading(ComboBox2.SelectedIndex + 2)
    strainC = P3.CurrentReading(ComboBox3.SelectedIndex + 2)

    '**Dummy values for labels to test when out of lab**
    'strainA = 2 * i ^ 2
    'strainB = 20 - 2 * i ^ 2
    'strainC = i ^ 3

    '**displays strains from each location in appropriate label**
    Label14.Text = strainA
    Label16.Text = strainB
    Label18.Text = strainC

    '**while number of loads to be applied has not been met, show strains for each load**
    If i < loadcount Then
        With oSheet
            .Cells(3, 4) = 0
            .Cells(3, 5) = 0
            .Cells(3, 6) = 0
            .Cells(3, 7) = 0
            .Cells(4 + i, 4) = appload
            .Cells(4 + i, 5) = strainA
            .Cells(4 + i, 6) = strainB
            .Cells(4 + i, 7) = strainC
        End With

        '**add X and Y values to chart in the interface**
        Chart1.Series("Strain at A").Points.AddXY(appload, strainA)

```

```

Chart1.Series("Strain at B").Points.AddXY(apload, strainB)
Chart1.Series("Strain at C").Points.AddXY(apload, strainC)
Chart1.Series("Strain at A").ChartArea = "ChartArea1"
Chart1.Series("Strain at B").ChartArea = "ChartArea1"
Chart1.Series("Strain at C").ChartArea = "ChartArea1"
End If

**increase counter by 1 for current load number**
i = i + 1
**increase progress bar by 1 per load**
ProgressBar1.Value = ProgressBar1.Value + 1

**Instructions for program after progress bar has been filled**
If ProgressBar1.Value = loadcount Then

    **Create ranges for Excel Chart**
    RngLoad = oSheet.Range(oSheet.Cells(3, 4), oSheet.Cells(4 + i, 4))
    RngA = oSheet.Range(oSheet.Cells(3, 5), oSheet.Cells(4 + i, 5))
    RngB = oSheet.Range(oSheet.Cells(3, 6), oSheet.Cells(4 + i, 6))
    RngC = oSheet.Range(oSheet.Cells(3, 7), oSheet.Cells(4 + i, 7))

    **Set-up Excel Chart and add ranges from data**
    With oChart
        .ChartType = XIChartType.xlLine
        **Create Title**
        .HasTitle = True
        .ChartTitle.Text = "Combined Loading Strain"
        **Create Axes**
        oLoadnum = CType(oChart.Axes(, XIAxisGroup.xlPrimary), Axes)
        oLoadnum.Item(XIAxisType.xlCategory).HasTitle = True
        oLoadnum.Item(XIAxisType.xlCategory).AxisTitle.Characters.Text = "Load"
        oStrain = CType(oChart.Axes(, XIAxisGroup.xlPrimary), Axes)
        oStrain.Item(XIAxisType.xlValue).HasTitle = True
        oStrain.Item(XIAxisType.xlValue).AxisTitle.Characters.Text = "Strain"
        **Create Legend**
        .HasLegend = True
        .SeriesCollection(1).name = "Strain at A"
        .SeriesCollection(2).name = "Strain at B"
        .SeriesCollection(3).name = "Strain at C"
        **Supply X and Y Values**
        With oStrA
            .XValues = RngLoad
            .Values = RngA
        End With
        With oStrB
            .XValues = RngLoad
            .Values = RngB
        End With
        With oStrC
            .XValues = RngLoad
            .Values = RngC
        End With
        **Set Chart Size and Position**
        .ChartArea.Height = 300
        .ChartArea.Width = 305
        .ChartArea.Top = 207
        .ChartArea.Left = 18
    End With

```

```

**Format Excel Sheet**
With oSheet
    .Columns("A").ColumnWidth = 15
    .Columns("B").ColumnWidth = 12
    .Columns("D").ColumnWidth = 12
    .Columns("E").ColumnWidth = 10
    .Columns("F").ColumnWidth = 10
    .Columns("G").ColumnWidth = 10
    .Columns("A:G").HorizontalAlignment = -4108
End With

**flag to signal the the Excel book has been closed**
bookcloseflag = 1

**Notifies user that they are done**
MessageBox.Show("All Done! Click End Experiment to Save and Exit!")
End If
End Sub
Private Sub Button3_Click(ByVal sender As System.Object, ByVal e As System.EventArgs) Handles Button3.Click
**Flag for showing that the "end" button has been clicked**
appcloseflag = 2

**Save file to folder as long as it exists, replace if file already exists**
**oBook.Close() closes the Excel book but not Excel**
If foldername Is Nothing Then
ElseIf i < loadcount Then
    oBook.Close()
Else
    If My.Computer.FileSystem.FileExists(savelocation & "\" & foldername & "\" & fname & ".xlsx") = False Then
        oBook.SaveAs(savelocation & "\" & foldername & "\" & fname & ".xlsx")
        oBook.Close()
    ElseIf My.Computer.FileSystem.FileExists(savelocation & "\" & foldername & "\" & fname & ".xlsx") = True
Then
        replacemsg = MsgBox("This file already exists, would you like to overwrite with the current file?", vbYesNo +
vbQuestion, "Replace Alert")
        If replacemsg = 6 Then
            oBook.SaveAs(savelocation & "\" & foldername & "\" & fname & ".xlsx")
            oBook.Close()
        ElseIf replacemsg = 7 Then
            oBook.Close()
        End If
    End If
End If
**Turns Alerts back on, closes Excel and interface form**
oExcel.DisplayAlerts = True
oExcel.Quit()
Me.Close()
End Sub
Private Sub Button4_Click(ByVal sender As System.Object, ByVal e As System.EventArgs) Handles Button4.Click
**button to change where to results**
**browse computer for new location**
System.IO.File.WriteAllText("C:\Save Directory\Combined Loading\savedirectory.txt", "")
If FolderBrowserDialog1.ShowDialog() = DialogResult.OK Then
    selectedsavelocation = FolderBrowserDialog1.SelectedPath
End If
savefile = My.Computer.FileSystem.OpenTextFileWriter("C:\Save Directory\Combined Loading\savedirectory.txt",
True)
savefile.WriteLine(selectedsavelocation)
savefile.Close()

```

```

    **read .txt file that contains new save location**
    readsavelocation = My.Computer.FileSystem.ReadAllText("C:\Save Directory\Combined
Loading\savedirectory.txt")
    savelocation = readsavelocation.Trim()
    TextBox11.Text = savelocation
End Sub
Private Sub CombinedLoading_FormClosing(ByVal sender As System.Object, ByVal e As
System.Windows.Forms.FormClosingEventArgs) Handles MyBase.FormClosing
    If appcloseflag = 1 Then
        **Close P3 device**
        P3.DeviceOpen = False
    End If
    **double check that everything has been closed and save alerts in Excel have been turned back on**
    If appcloseflag = 2 Then
    ElseIf appcloseflag = 0 Or appcloseflag = 1 Then
        If Err.Number = 0 Then
            oBook.Close()
        End If
        oExcel.DisplayAlerts = True
        oExcel.Quit()
    End If

    **message for user if P3 device was not connect properly**
    If Err.Number <> 0 Then
        MessageBox.Show("Please Reconnect P3 and Start Again")
    Else
    End If

End Sub
End Class

```