

11-4-2003

Stormwater Basins and Aesthetics – Not a Contradiction!

Amy Prouty Gill
City of Nashua

Alan G. LeBlanc
CDM

John Z. Olcott Jr.
CDM

Follow this and additional works at: <https://digitalcommons.usm.maine.edu/cbep-presentations>

Recommended Citation

Gill, A.P., LeBlanc, A.G., & Olcott, Jr., J.Z. (2003). Stormwater Basins and Aesthetics – Not a Contradiction!. [Presentation slides]. Portland, ME: University of Southern Maine, Muskie School of Public Service, Casco Bay Estuary Partnership.

This Book is brought to you for free and open access by the Casco Bay Estuary Partnership (CBEP) at USM Digital Commons. It has been accepted for inclusion in Presentations by an authorized administrator of USM Digital Commons. For more information, please contact jessica.c.hovey@maine.edu.



Stormwater Basins and Aesthetics – Not a Contradiction!

Amy Prouty Gill – City of Nashua

Alan G. LeBlanc, P.E. – CDM

John Z. Olcott, Jr., R.L.A. - CDM

November 4, 2003

Nashua, New Hampshire – Introduction

- ◆ **Southern New Hampshire**
 - ◆ **Population 86,000(+)**
 - ◆ **Sewer Service Population 100,000**
- ◆ **January Average Low Temp. = 12° F**
- ◆ **270 miles gravity sewer (~25% of area has combined sewers)**



Looking Ahead – EPA’s Final NPDES Phase II Stormwater Rule



- ◆ As of 1997, experienced as many as 197 CSO discharges annually.
- ◆ 1997: Global assessment of alternatives; study used to select most cost-effective approach; accepted by state.
- ◆ 1999: City made policy decision to institute an integrated infrastructure program - Administrative Order issued
- ◆ 2000-2003: New City administration re-assessed this policy & reviewed available alternatives

Stormwater Management in Nashua - Going Forward

- ◆ Approach will feature combination of elements identified in study - storage, treatment, and limited separation



- ◆ Implementing localized separation, storage, and/or treatment as necessary

- ◆ Anniversary Park Stormwater Detention Basin – First Implementation of This Approach!



How This Project Evolved

- ◆ Summer 2001 Flood Strikes Nashua!
- ◆ Sargents Avenue Area Flooded
- ◆ CDM Already Designing Sewer Separation Throughout Nashua
- ◆ Cost-Effective, Sensible Solution Needed!



Project Area Characteristics

- ◆ 31-Acre Suburban Neighborhood
- ◆ Undersized / Overloaded Combined Sewer
- ◆ Flat Terrain
- ◆ Nashua River 2 Miles Away

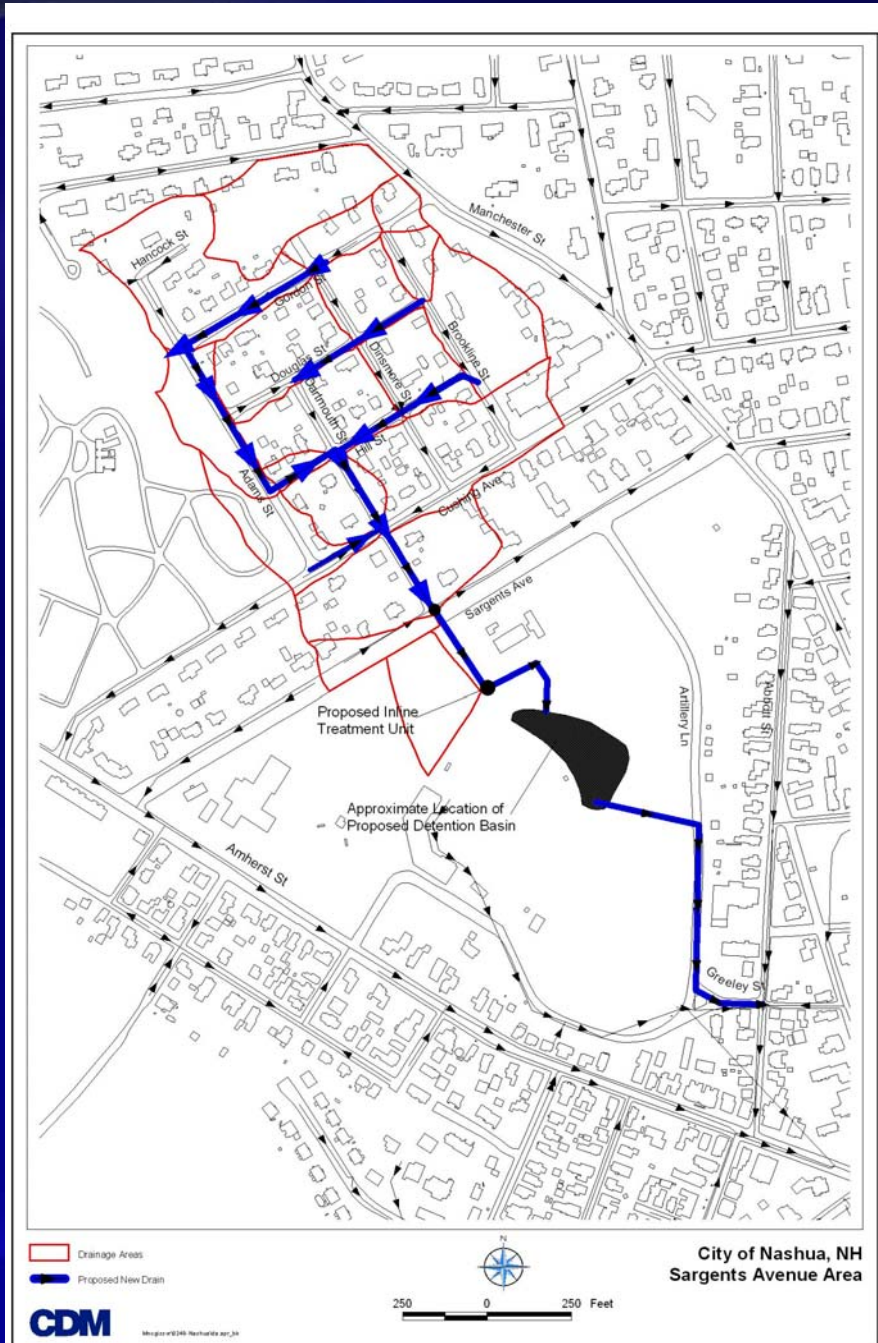

Selected Remedy

- ◆ Detention Basin with Local Sewer Separation
- ◆ Detain & Restrict Flow
- ◆ Shave Peak, Bleed Back
- ◆ Achieve Some Treatment

- ◆ Re-Build Infrastructure



Implementing the Solution

- ◆ **\$2.4M Construction Bid; 12-months to Substantial Completion**
- ◆ **2-Cell Detention Basin & Stormwater Treatment Unit Upstream of Basin**
- ◆ **Under-used Piece of Property Revitalized!**
- ◆ **How to Make It All Look Good?**



Poorly Utilized Land Creates a “Wet Meadow”

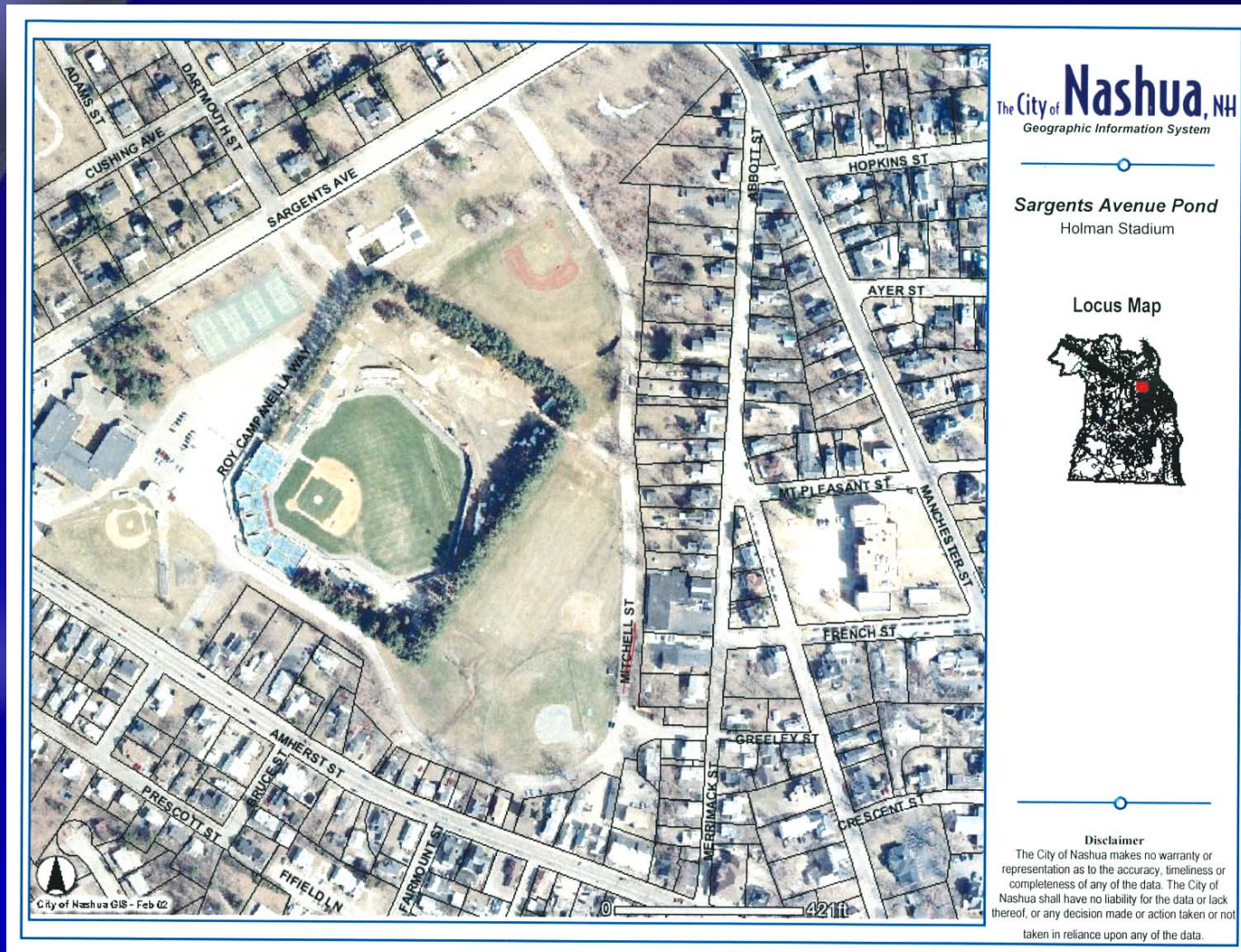

Typical Basin



The Ugly, and Unusable, Hole in the Ground



Keep Out



Keep Out...again



Know the Subsurface Conditions



After seeding



Years later



Other Uses



Golf Course Water Hazard Irrigation Source



Create a "Passive Recreational Park"



A Featureless Site



Alternative #1 – Single Cell Basin



Alternative #2 – Double Cell Basin



Path Placement



Know the Site Users



Basin Overflow/Spillway Area



Stone Arched Culvert



Precast Concrete Structure

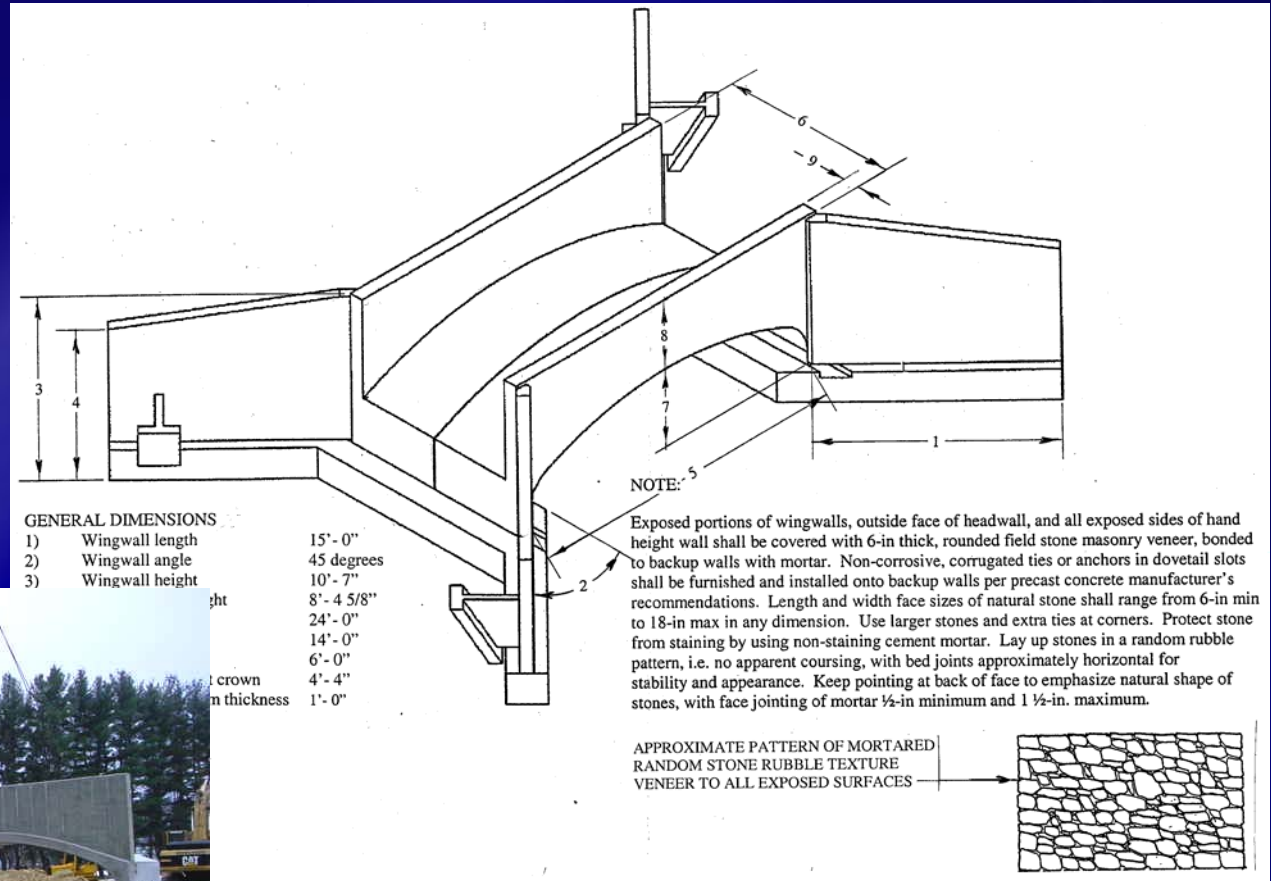

New Park Features



Handicap Access



Stones in Channel



Lower Basin Outlet Area

Upper Basin Inlet Area



Wildlife Habitat



Stonework



Native Vegetation



Plants in Naturalized Groupings



“Showcase of Nature”



Multi-Discipline Design



Dedication

