

# Wearable Activity Monitoring System for Detection of Estrus in A Sheep Farm

Elang Parikesit<sup>1</sup> and Petrus Sutiyasadi<sup>2</sup>

<sup>1,2</sup> Sanata Dharma Polytechnic of Mechatronics, Yogyakarta, Indonesia

E-mail : <sup>1</sup> [elang@pmsd.ac.id](mailto:elang@pmsd.ac.id), <sup>2</sup> [peter@pmsd.ac.id](mailto:peter@pmsd.ac.id)

**Abstract--** We have carried out the design of estrus detection tool for the large-scale farm of sheep. Estrus is a regular period of sexual receptivity in female mammals. Basically there are some ways to determine the time of estrus in cattle, which is based on body heat, bioimpedance or motion (activity). These tools have been used in some large-scale farms in developed countries. While in developing countries they are less popular because the price is quite expensive. In this study, a low cost system is designed based on the method of activity measurement using IMU sensor. Activities of sheep sensed by the IMU sensor will be processed by a microcontroller, then to be sent wirelessly to a remote monitor computer.

**Keywords—**estrus;wearable system; IMU;accelerometer; gyroscope

## I. INTRODUCTION

Things that are usually done in a large-scale farm are Artificial Inseminations (AI). In order for obtaining successful artificial insemination, insemination process should be done on the right time (estrus). Estrus estrus in cattle is the period of one estrus to the next estrus. The average estrus period of sheep is 17 days. [2]. Failure to artificial insemination would lead to money wasting. Efficient and profitable reproductive performance of a cattle requires routine but thorough heat detection and proper timing of artificial insemination. Estrus (heat) detection failure is a major factor contributing to low fertility. Approximately half of the heats are undetected on dairy farms in the United States [1].

Until now the determination of estrus period in the sheep farming is mostly done through the visual observation. The observation is not always appropriate. It is expected that by using a special tool to detect estrus, artificial insemination success rate will increase. Fortunately there are some ways to determine the time of estrus in cattle, which is based on body heat, bioimpedance or motion (activity). Some commercially available estrus detection tools have been used in some large-scale farms in developed countries, but the price is quite expensive.

Kiddy (1976) reported that cows in free stalls were about 2.75 times as active during estrus as when not in estrus. There was relatively little variation within cow in activity from day to day among cows not in estrus. [3]. Neary et. al. (2003) also showed that restlessness is an important external indicator for incidence of estrus in other farm animals, such as goat, sheep,

horse, and swine. There was significantly higher activity rates on the day of estrus than on any other day [4].

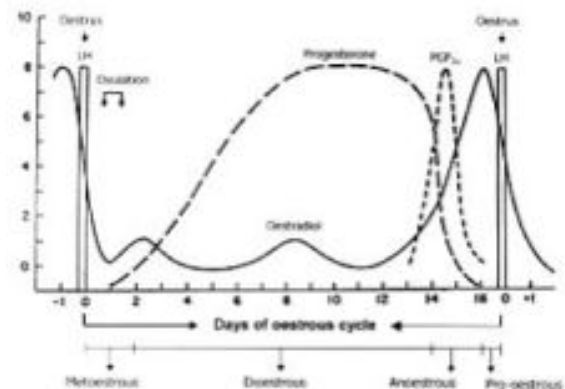

Fig. 1. Estrus cycle in the ewe (female sheep)

## II. SYSTEM HARDWARE

Block diagram of the wearable activity monitoring system is shown in figure 2. Data from the IMU sensor (accelerometer and gyroscope) received by the microcontroller will be computed using a Kalman filter algorithm programmed in it. Estimated value of position will be sent to a PC to be displayed in graphical form.

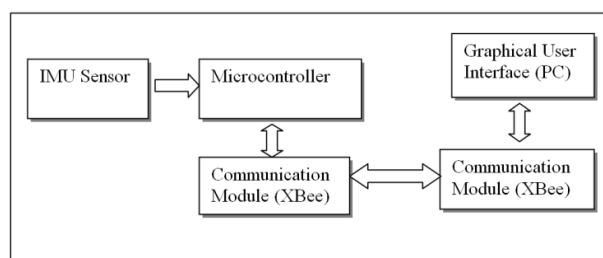

Fig. 2. Block Diagram of Wearable Activity Monitoring System

### a. IMU sensor

An IMU sensor (a combination of an accelerometer and a gyroscope) will be used to measure the position of a sheep during its activities. An accelerometer is a device to measure static and dynamic acceleration. Earth gravity as a static acceleration will be detected also by the accelerometer.

Therefore, an accelerometer can be used to detect orientation of the sheep.

Gyroscope is a device to measure rate angle, which output needs to be integrated to get angle value. Integration of that output is noisy so that the final result is drifted due to the noise integration along the time process. Because the accelerometer measurement process can be so noisy and the gyro measurement process can give a drifted value, both of their process will be fused by using Kalman Filter algorithm.

A combination of accelerometer and gyroscope called a combo IMU sensor. IMU sensor being used in this system is 6 degrees IMU sensor ADXL345 and ITG3200 from Sparkfun [5].

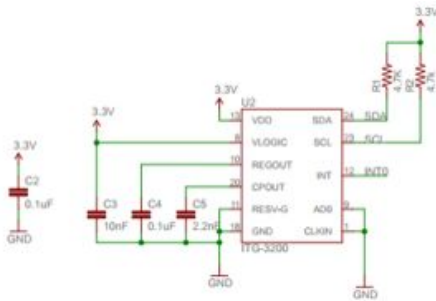

Fig. 3. Schematic circuit in using the ITG3200

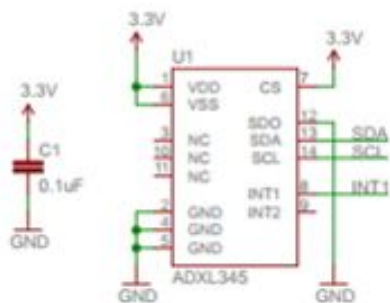

Fig.4. Schematic circuit in using the ADXL345

#### b. Microcontroller

Arduino is an open-source single-board microcontroller, designed to make the process of using electronics in multidisciplinary projects more accessible. The hardware consists of a simple open hardware design for the Arduino board with an Atmel AVR processor and on-board I/O support. The software consists of a standard programming language compiler and the boot loader that runs on the board [6].

Signals from accelerometer and gyro (IMU) are connected to the Arduino analog inputs. The Kalman algorithm in this microcontroller will update the estimated angle every several milliseconds. Then the position angle during sheep activities will be acquired by the IMU sensor placed on the sheep's leg or collar. Placement of the system on sheep's body is in figure 5.

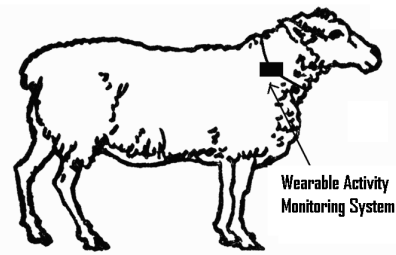

Fig. 5. Placement of the wearable system

#### c. Wireless Data Communication

XBee RF module is a wireless communication device designed with the IEEE 802.15.4 standard protocol. It is suitable for simple wireless networks, works at low voltage (3.3 V) and has lower power consumption. This module operates at 2.4 GHz frequency range [7]. Figure 6 and figure 7 respectively show XBee module as a transmitter and a receiver.

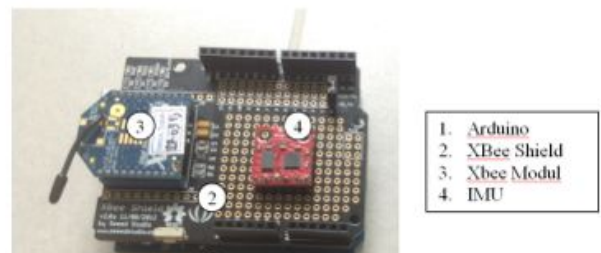

Fig. 6. Transmitter side (Arduino, IMU, XBee and XBee shield)



Fig. 7. Receiver side (XBee module and dongle)

### III. SOFTWARE

#### a. Discrete Kalman Filter

Kalman filter was developed by Dr.R.E. Kalman in 1960. It is a kind of recursive solution to discrete data linear filtering problem. Figure 8 shows how the Kalman Filter works.

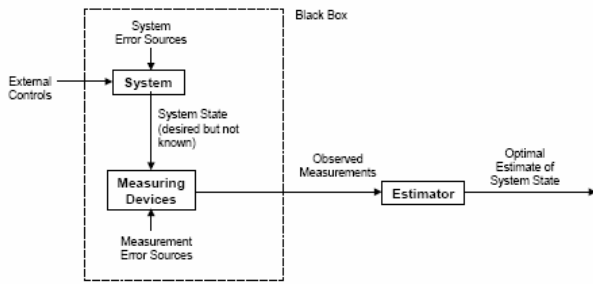

Fig. 8. Block diagram of how the Kalman filter works

Kalman filter will estimate the correct states of the system in the presence of disturbance and measurement noise. Kalman filter works by minimizing the mean squared error between the actual and estimated data. [8]

Consider a linear system described in the following equation:

$$x_k = Ax_{k-1} + Bu_{k-1} + w_{k-1} \dots\dots\dots (1)$$

Output equation:

$$z_k = Hx_k + v_k \dots\dots\dots (2)$$

The random variables  $w$  and  $v$  are the process and measurement noise respectively. These two noises are assumed having normal probability distribution with mean zero and independent of each other or white noise.

The Kalman algorithm works in two steps:

1. The first step in the algorithm is to predict the state. This is the first of the estimation, called the a priori state estimate.

2. The next step is to update the state of the a priori estimates with feedback from the sensors. Updated feedback estimate is called "a posteriori" state estimate.

Kalman filter through this cycle continues to update the assessment and prediction of the state from the measurement of the sensors. Continuous cycle algorithm is shown below:



Fig. 9. Continuous loop of Kalman filter algorithm

In the priory state estimate some initial value should be described. Initial estimate state and estimated initial error covariance should be entered. In the meantime noise covariance  $R_0$  and covariance  $Q_0$  voice process are should be known. Predictor equations are shown below;

$$\dot{\hat{x}}_k = A\hat{x}_{k-1} + Bu_{k-1} \dots\dots\dots (3)$$

$$\dot{P}_k = AP_{k-1}A^T + Q \dots\dots\dots (4)$$

Where  $A$  is the states matrix,  $B$  is the input matrix, and  $Q$  is the process noise covariance matrix. State estimate of the

state variable is calculated by equation 3. Equation 4 calculates an estimate of the error covariance matrix. This is the error between the true state variable  $x$ , and the estimate of  $x$ . The next set of equations is the measurement update equations:

$$K_k = \dot{P}_k H^T (H \dot{P}_k H^T + R)^{-1} \dots\dots\dots (5)$$

$$\hat{x}_k = \dot{\hat{x}}_k + K_k (z_k - H \dot{\hat{x}}_k) \dots\dots\dots (6)$$

$$P_k = (I - K_k H) \dot{P}_k \dots\dots\dots (7)$$

Where  $H$  is the measurement matrix and  $R$  is the measurement covariance matrix. Gain matrix that minimizes the error covariance  $P$  is calculated by equation 5. Equation 6 computes the 'a posteriori' state estimate or the measurement update estimate. The 'a posteriori' state estimate is a linear function of the 'a priori' state estimate and the weighted error between the measurement and the 'a priori' state estimate. The last equation 7, computes the 'a posteriori' covariance matrix.

#### b. Sensor Fusion Using Kalman Filter

Accelerometer will compensate the drift that is produced by the gyroscope. However, in the accelerometer measurement presents some significant noise also. Kalman filter will combine these two measurements and produce the optimal result that free from drift and minimum noise. The two sensors are fused using two states Kalman filter, with one state is the angle and the other state is the gyro bias.

Steps on fusion the gyro and accelerometer using Kalman filter:

1. Define the update rate  $dt$ . This is how often the state is updated with gyro rate measurements.
2. Define the measurement covariance noise  $R$
3. Define the process covariance noise  $Q$
4. Define the covariance matrix update
  - a.  $P_{k+1}^- += P_{dot} * dt$
  - b.  $P_{dot} = A * P_k + P_k * A^T + Q$
5. Define the estimated state update
  - a.  $angle^+ += g * dt$
  - b.  $g = gyro\_measurement - gyro\_bias$
6. Step 4 and 5 will be updated every  $dt$
7. Define the Kalman Gain.  $K = P_{k+1}^- * C^T * (C * P_{k+1}^- * C^T + R)^{-1}$
8. Update the covariance matrix.  $P_{k+1} = (I - K * C) * P_{k+1}^-$
9. Update the state estimate.  $X^+ += K * (angle\_accel\_meas - angle)$
10. Step 7,8, and 9 will be updated every accelerometer reading is ready

#### IV. RESULTS AND DISCUSSION

We have conducted an experiment on a simulated subject. Figure 10-13 showed the output of the activity monitoring system developed in this study. Comparing the IMU sensor data of high activity (figure 13) with data of less activity (figure 12) of the monitored subject, we can see that it was sufficiently different to detect estrus

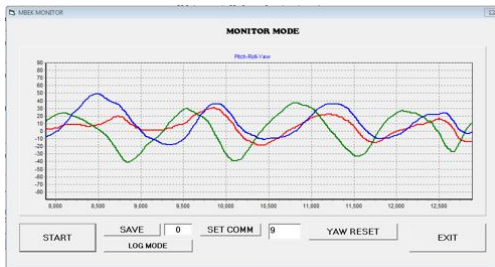

Fig. 10. Activity Monitoring Software with log mode or monitor mode

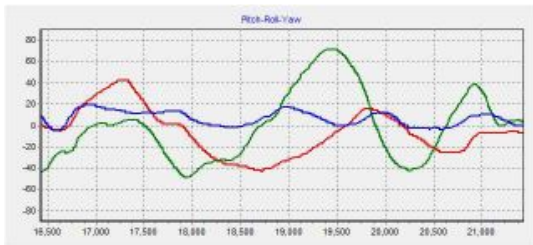

Fig.11. Medium Activity

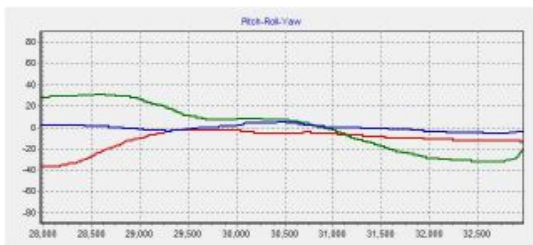

Fig. 12. Less Activity

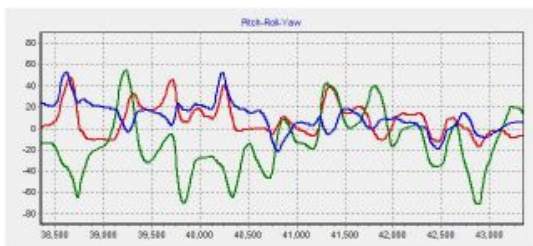

Fig. 13. High Activity

## V. CONCLUSION AND FUTURE WORK

A wearable cattle (sheep) activity monitoring system based on IMU sensor has developed successfully. It is portable, wearable and expected not to interfere the natural movement of the subject being monitored. The system is low cost and it can measure subject in movement. This system can be used for observing whether or not a sheep is in its estrus period.

However this study is still conducted on the simulated subject. Future work will focus on implementation in a real subject and environment.

## REFERENCES

- [1] Michael L. O'Connor, *Heat Detection and Timing of Insemination for Cattle*, Pennsylvania State University, 1993
- [2] Aminoor Rahman, "Hormonal Changes in the Uterus During Pregnancy- Lessons from the Ewe, A Review," *Journal of Agriculture and Rural Development*. June 2006
- [3] Charles A. Kiddy, "Variation in Physical Activity as an Indication of Estrus in Dairy Cows," *Journal of Dairy Science*, Volume 60, issue 2. February 1977
- [4] Michael Neary, Wayne Singleton, and Ann Yager, *Estrus Detection in Farm Animals*, Purdue University Cooperative Extension Service, 2003, [Online]. Available: <http://www.extension.purdue.edu/extmedia/AS/AS-559-W.pdf>
- [5] Sparkfun, *IMU Digital Combo Board - 6 Degrees of Freedom ITG3200/ADXL345*, [Online]. Available: <https://www.sparkfun.com/products/10121>
- [6] Arduino Homepage, <http://arduino.cc/>
- [7] Digi International, *XBee / XBee Pro OEM RF Modules Product Manual*, 2003
- [8] Greg Welch and Gary Bishop (2006), *An Introduction to the Kalman Filter*, [Online]. Available: [http://www.cs.unc.edu/~welch/media/pdf/kalman\\_intro.pdf](http://www.cs.unc.edu/~welch/media/pdf/kalman_intro.pdf)