

Polarization beating of random electromagnetic beams

H. Lajunen

Institute of Photonics, University of Eastern Finland, P. O. Box 111, FI-80101 Joensuu, Finland

J. Salaj

Institute of Photonics, University of Eastern Finland, P. O. Box 111, FI-80101 Joensuu, Finland

T. Setälä

tero.setala@uef.fi

Institute of Photonics, University of Eastern Finland, P. O. Box 111, FI-80101 Joensuu, Finland

We consider temporal interference of two stationary, quasi-monochromatic, partially polarized optical beams with different mean frequencies. We show that both the intensity and the polarization state, represented by the Stokes parameters, exhibit beating, i.e., periodic temporal variation with frequency specified by the difference of the mean frequencies. The contrasts, or visibilities, of the Stokes-parameter changes are characterized by the equal-time electromagnetic degree of coherence between the beams. If the beams are otherwise identical random processes, but with spectra centered at different frequencies, then the polarization modulation is characterized by the degree of polarization, consistently with a recent interferometric interpretation of this quantity. Our results provide insight into the role of polarization in beating of electromagnetic waves.

[DOI: <http://dx.doi.org/10.2971/jeos.2016.16011>]

Keywords: Beating, electromagnetic coherence, polarization

1 INTRODUCTION

Coherence of scalar light fields and partial polarization of electromagnetic beams are well-developed topics formulated both in space-time and space-frequency domains [1]–[3]. The studies have almost exclusively concentrated on the statistical properties of stationary beams and on coherence/correlation at one or more points in a single field. Investigations dealing with coherence of a pair of wave fields appear to be rare [4].

Beating is a temporal interference effect where a pair of wave fields with different frequencies produce periodically varying intensity pattern. Beating is usually formulated for monochromatic and hence fully correlated fields and it is well known in the context of sound waves. However, beating effects are found also for light waves. Indeed, mode-locking is a multi-frequency beating effect where correlated longitudinal laser modes interfere to produce ultrashort light pulses, non-linear light-matter interactions can produce correlated frequencies, optical heterodyne detection is essentially based on beating, and electro-optic and acousto-optic modulators can produce frequency shifts suitable for generating beating that is observable with modern photodetectors [5].

In this work, we consider temporal interference of two random, statistically stationary, quasi-monochromatic, partially polarized light beams having different mean frequencies. Our focus is on electromagnetic light, but for completeness we briefly also consider beating of quasi-monochromatic scalar beams for which the effect shows up as temporal intensity variations. The scalar treatment also emphasizes certain requirements on the detection of beating with random light and

points out the validity conditions of the formalism. For electromagnetic beams not only the intensity but also the polarization state, both elegantly expressed in terms of the traditional Stokes parameters, may undergo beating. The amplitudes of the Stokes-parameter variations are characterized by the equal-time electromagnetic degree of coherence [6]–[10] between the interfering fields. When one of the random electromagnetic beams is a copy of the other one but with different mean frequency, as obtained, e.g., by phase modulation, the amplitude of the polarization beating is described by the degree of polarization. This is consistent with the recent interferometric interpretation of the degree of polarization as a quantity that characterizes the ability of a field to produce polarization modulation when it interferes with itself [9].

This paper is organized as follows. Sections 2 and 3 focus on beating with scalar and electromagnetic beams, respectively. In Section 4 self beating of vectorial light is studied and in Section 5 we summarize the main results of this work.

2 BEATING OF SCALAR QUASI-MONOCROMATIC WAVES

Let us first consider two stationary, quasi-monochromatic scalar beams propagating in the same direction in free space. At an instant of time t the fields are represented by the zero-mean complex analytic signals [1]

$$U_m(t) = A_m(t) \exp(-i\omega_m t), \quad m \in (1, 2), \quad (1)$$

where the envelopes, $A_m(t)$, are slowly varying in time. The spectra of the waves are narrow peaks of widths, $\delta\omega_m$, around the mean frequencies, ω_m , obeying $\delta\omega_m/\omega_m \ll 1$. We have dropped the explicit dependence on the spatial coordinate and assume that the waves are considered at a fixed point.

The temporal coherence properties of the individual waves are described by the mutual coherence functions defined as [1]

$$\begin{aligned} \Gamma^{(m)}(\tau) &= \langle U_m^*(t)U_m(t+\tau) \rangle, \\ &= \Gamma_A^{(m)}(\tau) \exp(-i\omega_m\tau), \quad m \in (1,2), \end{aligned} \quad (2)$$

where

$$\Gamma_A^{(m)}(\tau) = \langle A_m^*(t)A_m(t+\tau) \rangle, \quad m \in (1,2), \quad (3)$$

are the (slowly-varying) mutual coherence functions related to the envelopes. In addition, the asterisk denotes complex conjugation and the angle brackets stand for an ensemble average. Since the fields are assumed to be ergodic the ensemble average equals the time average over a single realization. The above coherence functions of individual waves depend on time through the time difference τ only demonstrating stationarity of the waves. Consequently, the intensities of the waves are

$$I^{(m)} = \Gamma^{(m)}(0) = \Gamma_A^{(m)}(0), \quad m \in (1,2), \quad (4)$$

which do not depend on time.

We can introduce the cross-correlation function that characterizes the correlation between the two waves; explicitly

$$\begin{aligned} \Gamma^{(12)}(t_1, t_2) &= \langle U_1^*(t_1)U_2(t_2) \rangle, \\ &= \Gamma_A^{(12)}(\tau) \exp[-i(\omega_2t_2 - \omega_1t_1)], \end{aligned} \quad (5)$$

where

$$\Gamma_A^{(12)}(\tau) = \langle A_1^*(t)A_2(t+\tau) \rangle, \quad (6)$$

with $\tau = t_2 - t_1$. The angle brackets must now be understood as an ensemble average. Eq. (5) shows that the correlation function of two stationary, quasi-monochromatic fields of different mean frequencies does not depend on time through the time difference only. If $\omega_1 = \omega_2$ then pure τ -dependence must be found. For this reason the slowly-varying function $\Gamma_A^{(12)}(\tau)$ must depend only on τ as it has no information on the mean (carrier) frequencies.

The two-field correlation function of Eq. (5) has the property $\Gamma^{(21)}(t_2, t_1) = [\Gamma^{(12)}(t_1, t_2)]^*$. Furthermore, we may normalize it by the intensities given in Eq. (4) and introduce the (complex) degree of coherence (correlation) between the waves as

$$\gamma^{(12)}(t_1, t_2) = \frac{\Gamma^{(12)}(t_1, t_2)}{\sqrt{\Gamma^{(1)}(0)\Gamma^{(2)}(0)}}, \quad (7)$$

$$= \gamma_A^{(12)}(\tau) \exp[-i(\omega_2t_2 - \omega_1t_1)], \quad (8)$$

where

$$\gamma_A^{(12)}(\tau) = \frac{\Gamma_A^{(12)}(\tau)}{\sqrt{\Gamma_A^{(1)}(0)\Gamma_A^{(2)}(0)}}, \quad (9)$$

is the degree of coherence between the slowly-varying wave envelopes. The two degrees obey $0 \leq |\gamma^{(12)}(t_1, t_2)| \leq 1$ and $0 \leq |\gamma_A^{(12)}(\tau)| \leq 1$ with the lower and upper limits indicating complete incoherence (non-correlation) and coherence (correlation) between the fields, respectively. The functions $\gamma^{(12)}(t_1, t_2)$ and $\gamma_A^{(12)}(\tau)$ differ by a deterministic factor $\exp[-i(\omega_2t_2 - \omega_1t_1)]$ whose presence, in fact, leads to beating.

Consider next the superposition of the two quasi-monochromatic waves with different mean frequencies. The total field is

$$\begin{aligned} U(t) &= U_1(t) + U_2(t), \\ &= \exp(-i\omega_1t)[A_1(t) + A_2(t) \exp(-i\Delta\omega t)], \end{aligned} \quad (10)$$

where $\Delta\omega = \omega_2 - \omega_1$. Intensity of the field becomes

$$\begin{aligned} I(t) &= \langle |U(t)|^2 \rangle, \\ &= I^{(1)} + I^{(2)} + 2\text{Re} \left[\Gamma_A^{(12)}(0) \exp(-i\Delta\omega t) \right], \\ &= I^{(1)} + I^{(2)} \\ &\quad + 2\sqrt{I^{(1)}I^{(2)}} |\gamma_A^{(12)}(0)| \cos \left\{ \arg[\gamma_A^{(12)}(0)] - \Delta\omega t \right\}, \end{aligned} \quad (11)$$

where Eqs. (9) and (4) were used and \arg denotes the argument of a complex number. Intensity of the sum field, thus, varies sinusoidally with time exhibiting beating. The angular frequency of the modulation is $\Delta\omega$, while its amplitude is specified by the magnitude of the equal-time degree of coherence between the waves, $|\gamma_A^{(12)}(0)|$. When $\Delta\omega = 0$ beating vanishes. Likewise if the two waves are uncorrelated beating does not occur.

Eq. (11) characterizing temporal interference is similar to that found for the spatial interference fringes in Young's interferometer [1]. In that case, the fields from two spatial points (apertures) interfere at the Fourier plane and produce intensity fringes whose period depends on the distance of the openings. In the present context, two fields centered at two frequencies interfere in time (Fourier) domain and produce intensity fringes whose periodicity is specified by the distance of the two frequencies. In both cases, the amplitude and displacement of the variations depend on the degree of coherence.

The average in Eq. (11) should again be understood as an ensemble average, which, however, does not always correctly describe the experimental situation involving time averages [11]. The instantaneous intensity of the total field is of the form

$$\begin{aligned} \mathcal{I}(t) &= |U(t)|^2 = |A_1(t)|^2 + |A_2(t)|^2 \\ &\quad + 2\text{Re} [A_1^*(t)A_2(t) \exp(-i\Delta\omega t)]. \end{aligned} \quad (12)$$

We denote the average of signal $S(t)$ over a short time interval \mathcal{T} around t by

$$\langle S(t) \rangle_{\mathcal{T}} = \frac{1}{\mathcal{T}} \int_{t-\mathcal{T}/2}^{t+\mathcal{T}/2} S(t') dt', \quad (13)$$

which in general depends on t . Assume first that the beating period $T = 2\pi/\Delta\omega$ is much larger than \mathcal{T} . For

comparison, a typical frequency shift obtained with an acousto-optical or electro-optical modulator could be $10 \text{ MHz} \leq \Delta\omega/2\pi \leq 10 \text{ GHz}$ [5], corresponding to a beating period of $0.1 \text{ ns} \leq T \leq 0.1 \text{ }\mu\text{s}$. When $T \gg \mathcal{T}$ holds, we can take the exponential function in Eq. (12) out of the integral and write the average intensity as

$$\langle \mathcal{I}(t) \rangle_{\mathcal{T}} = \langle |A_1(t)|^2 \rangle_{\mathcal{T}} + \langle |A_2(t)|^2 \rangle_{\mathcal{T}} + 2\text{Re} [\langle A_1^*(t)A_2(t) \rangle_{\mathcal{T}} \exp(-i\Delta\omega t)]. \quad (14)$$

The time scales of random fluctuations of the slowly-varying envelopes are specified by the coherence times of the two interfering stationary fields. If \mathcal{T} is much larger than the coherence times, the finite time averages in Eq. (14) are, to a good approximation, independent of time, and moreover, equal to the ensemble average. In this case, Eq. (11) describes the beating effect correctly. We may, in fact, separate two time scales characterizing the beating phenomenon, a short one related to the statistical properties of light and where the coherence effects are introduced, as well as a long one pertaining to the (deterministic) beating period. Notice also that if the two waves originate from independent sources no beating takes place since the correlation coefficient in Eq. (11) vanishes.

If the coherence times are much longer than T (and hence larger than \mathcal{T} by assumption), the time averages of the slowly-varying quantities in Eq. (14) remain essentially unaltered over several beating periods. A beating effect is again observed, but the finite time averages change slowly with t and do not generally equal the related ensemble averages in Eq. (11). This case corresponds to the transient fringes discussed, e.g., in Ref. [11]. These temporal fringes are observed also for fields from independent sources [12]–[14] as is evident from the term $\langle A_1^*(t)A_2(t) \rangle_{\mathcal{T}}$ with essentially constant amplitudes. The limit of transient fringes is not described by Eq. (11). The ultimate limit for the tracking rapid intensity fluctuations and beating is set by the detector bandwidth which may approach 100 GHz corresponding to the time resolution of a few tens of pico seconds.

Notice also that when beating is observed, the average intensity varies with time and the superposition field is not stationary. On the other hand, if the beating period is much less than \mathcal{T} the effect disappears on averaging and we may, in practise, say that the field is stationary. These observations demonstrate that whether the field can be regarded as stationary or non-stationary depends essentially also on the detector. In addition to the above considerations, we note that by using a specific two-photon absorption technique to measure temporal intensity correlation functions, beating at femto-second time scale was recently observed [15].

3 BEATING OF QUASI-MONOCHROMATIC ELECTROMAGNETIC BEAMS

Consider next temporal interference of two stationary, quasi-monochromatic, partially polarized electromagnetic beams both propagating in the z direction. The zero-mean complex analytic signals associated with the electric vectors of the waves are $\mathbf{E}_m(t) = [E_{m,x}(t), E_{m,y}(t)]^T$, $m \in (1,2)$, where

$E_{m,x}(t)$ and $E_{m,y}(t)$ are the (transverse) x and y electric field components, respectively, and T denotes transpose. Invoking the envelope representation, the fields take the forms

$$\mathbf{E}_m(t) = \mathbf{A}_m(t) \exp(-i\omega_m t), \quad m \in (1,2), \quad (15)$$

where $\mathbf{A}_m(t) = [A_{m,x}(t), A_{m,y}(t)]^T$ and ω_m are the slowly varying amplitude and the mean frequency, respectively, of the beam m .

The coherence properties of the individual waves are characterized by the electric mutual coherence matrices given as [1]

$$\begin{aligned} \Gamma^{(m)}(\tau) &= \langle \mathbf{E}_m^*(t) \mathbf{E}_m^T(t + \tau) \rangle, \\ &= \Gamma_A^{(m)}(\tau) \exp(-i\omega_m \tau), \quad m \in (1,2), \end{aligned} \quad (16)$$

where

$$\Gamma_A^{(m)}(\tau) = \langle \mathbf{A}_m^*(t) \mathbf{A}_m^T(t + \tau) \rangle, \quad m \in (1,2), \quad (17)$$

is slowly varying with the time difference τ and the angle brackets may stand for an ensemble average or a time average. Information on the polarization properties and the intensities of the waves is contained in the polarization matrices defined as

$$\mathbf{J}^{(m)} = \Gamma^{(m)}(0) = \Gamma_A^{(m)}(0), \quad m \in (1,2). \quad (18)$$

An alternative but equivalent description of polarization is provided by the Stokes parameters [1, 3] which can be written as

$$S_n^{(m)} = \text{tr}(\sigma_n \mathbf{J}^{(m)}), \quad n \in (0, \dots, 3), \quad m \in (1,2), \quad (19)$$

where tr refers to the trace of matrix and σ_n are the Pauli matrices given by

$$\begin{aligned} \sigma_0 &= \begin{pmatrix} 1 & 0 \\ 0 & 1 \end{pmatrix}, \quad \sigma_1 = \begin{pmatrix} 1 & 0 \\ 0 & -1 \end{pmatrix}, \\ \sigma_2 &= \begin{pmatrix} 0 & 1 \\ 1 & 0 \end{pmatrix}, \quad \sigma_3 = \begin{pmatrix} 0 & i \\ -i & 0 \end{pmatrix}. \end{aligned} \quad (20)$$

The Stokes parameters of Eq. (19) are real valued and of the form

$$S_0^{(m)} = J_{xx}^{(m)} + J_{yy}^{(m)}, \quad (21)$$

$$S_1^{(m)} = J_{xx}^{(m)} - J_{yy}^{(m)}, \quad (22)$$

$$S_2^{(m)} = J_{xy}^{(m)} + J_{yx}^{(m)}, \quad (23)$$

$$S_3^{(m)} = i[J_{yx}^{(m)} - J_{xy}^{(m)}], \quad (24)$$

where $J_{ij}^{(m)} = \langle E_{m,i}^*(t) E_{m,j}(t) \rangle$, $(i, j) \in (x, y)$, are the elements of the polarization matrix $\mathbf{J}^{(m)}$, $m \in (1,2)$. The parameter $S_0^{(m)}$ is the intensity of the wave m , whereas $S_1^{(m)}$, $S_2^{(m)}$, and $S_3^{(m)}$ describe its polarization state. Both the polarization properties and the intensities are independent of time since the beams are stationary. We may normalize the Stokes parameters as

$$s_n^{(m)} = \frac{S_n^{(m)}}{S_0^{(m)}}, \quad n \in (0, \dots, 3), \quad m \in (1,2), \quad (25)$$

where $s_0^{(m)} = 1$, while $0 \leq s_n^{(m)} \leq 1$, for $n \in (1,2,3)$. Besides the polarization state, a central quantity in polarization optics

of random light beams is the degree of polarization which in terms of the normalized Stokes parameters reads for the two beams as

$$P^{(m)} = \left\{ \sum_{n=1}^3 [s_n^{(m)}]^2 \right\}^{1/2}, \quad m \in (1, 2). \quad (26)$$

Physically the degree of polarization describes the ratio of the intensity in the polarized part of the beam to the total intensity [1]. The degree of polarization is bounded between zero and one with the lower and upper limit corresponding to a fully unpolarized and a completely polarized beam, respectively.

In analogy to the scalar case, coherence or correlation between the two waves is described by the cross-correlation matrix

$$\begin{aligned} \Gamma^{(12)}(t_1, t_2) &= \langle \mathbf{E}_1^*(t_1) \mathbf{E}_2^T(t_2) \rangle, \\ &= \Gamma_A^{(12)}(\tau) \exp[-i(\omega_2 t_2 - \omega_1 t_1)], \end{aligned} \quad (27)$$

where

$$\Gamma_A^{(12)}(\tau) = \langle \mathbf{A}_1^*(t) \mathbf{A}_2^T(t + \tau) \rangle. \quad (28)$$

Due to different mean frequencies the cross-correlation matrix depends explicitly on both time variables although both fields are stationary. However, $\Gamma_A^{(12)}(\tau)$ depends only on the time difference since the conclusions below Eq. (6) for scalar fields hold for each element of this matrix. Instead of using the elements of the cross-correlation matrix, we may express the coherence properties in terms of the two-time Stokes parameters (two-point Stokes parameters but at a single spatial point [9], [16]–[18]) defined as

$$\mathcal{S}_n^{(12)}(t_1, t_2) = \text{tr} \left[\sigma_n \Gamma^{(12)}(t_1, t_2) \right], \quad (29)$$

$$= \mathcal{S}_{A,n}^{(12)}(\tau) \exp[-i(\omega_2 t_2 - \omega_1 t_1)]. \quad (30)$$

with $n \in (0, \dots, 3)$, and where

$$\mathcal{S}_{A,n}^{(12)}(\tau) = \text{tr} \left[\sigma_n \Gamma_A^{(12)}(\tau) \right], \quad (31)$$

are the two-time Stokes parameters related to the slowly-varying envelopes. Making use of the Pauli matrices listed in Eq. (20), the envelope parameters assume the forms

$$\mathcal{S}_{A,0}^{(12)}(\tau) = \Gamma_{A,xx}^{(12)}(\tau) + \Gamma_{A,yy}^{(12)}(\tau), \quad (32)$$

$$\mathcal{S}_{A,1}^{(12)}(\tau) = \Gamma_{A,xx}^{(12)}(\tau) - \Gamma_{A,yy}^{(12)}(\tau), \quad (33)$$

$$\mathcal{S}_{A,2}^{(12)}(\tau) = \Gamma_{A,xy}^{(12)}(\tau) + \Gamma_{A,yx}^{(12)}(\tau), \quad (34)$$

$$\mathcal{S}_{A,3}^{(12)}(\tau) = i[\Gamma_{A,yx}^{(12)}(\tau) - \Gamma_{A,xy}^{(12)}(\tau)], \quad (35)$$

where $\Gamma_{A,ij}^{(12)}(\tau) = \langle A_{1,i}^*(t) A_{2,j}(t + \tau) \rangle$, with $(i, j) \in (x, y)$, are the elements of $\Gamma_A^{(12)}(\tau)$. In analogy to the polarization Stokes parameters, we may introduce the intensity normalized two-time Stokes parameters as

$$\gamma_{A,n}^{(12)}(\tau) = \frac{\mathcal{S}_{A,n}^{(12)}(\tau)}{\sqrt{S_0^{(1)} S_0^{(2)}}}, \quad n \in (0, \dots, 3), \quad (36)$$

where $S_0^{(1)}$ and $S_0^{(2)}$ are the intensities of the waves given in Eq. (21). Above we have emphasized the two-time Stokes parameters related to the envelopes as they will appear in the following discussion. However, the complete two-time parameters are given in Eq. (30). They contain a deterministic phase

factor which depends on both time variables and is responsible for beating.

In analogy to the considerations of spatio-temporal [9] (or spectral [8]) coherence in Young’s interferometer and temporal coherence in Michelson’s interferometer [10] we introduce the electromagnetic degree of temporal coherence between two quasi-monochromatic electromagnetic beams with different mid frequencies (in squared form) as

$$\begin{aligned} \gamma_{EM}^2(\tau) &= \frac{\text{tr} \left\{ \Gamma^{(12)}(t_1, t_2) \left[\Gamma^{(12)}(t_1, t_2) \right]^\dagger \right\}}{\text{tr} \left[\Gamma^{(1)}(0) \right] \text{tr} \left[\Gamma^{(2)}(0) \right]} \\ &= \frac{\text{tr} \left\{ \Gamma_A^{(12)}(\tau) \left[\Gamma_A^{(12)}(\tau) \right]^\dagger \right\}}{S_0^{(1)} S_0^{(2)}} \\ &= \frac{1}{2} \sum_{n=0}^3 |\gamma_{A,n}^{(12)}(\tau)|^2. \end{aligned} \quad (37)$$

The second expression is found with the help of Eq. (27) and the last one is verified by inserting Eq. (36) into it and using Eqs. (32)–(35). Above the dagger indicates Hermitian adjoint. The electromagnetic degree of coherence is real valued and obeys $0 \leq \gamma_{EM}(\tau) \leq 1$, with the lower and upper bound reflecting complete incoherence and coherence between the vectorial fields, respectively. When the fields are mutually incoherent no correlation exists between any of the orthogonal components while for coherent fields all components are fully correlated [19]. In other contexts, it is known that the electromagnetic degree of coherence describes the modulation contrasts of the Stokes parameters in interference. In the case of Young’s interferometer, both the intensity and the polarization state at the observation screen may be spatially modulated and the sum of variation contrasts (visibilities) is given by the degree of coherence [8, 9]. Similarly, in Michelson’s interferometer temporal coherence induces intensity and polarization modulations whose contrasts are characterized by the electromagnetic degree of temporal coherence [10]. Similar result is found for the two-field degree of coherence of Eq. (37) as will be seen shortly.

Next we focus on the superposition of the two quasi-monochromatic beams given in Eq. (15). The sum field is

$$\begin{aligned} \mathbf{E}(t) &= \mathbf{E}_1(t) + \mathbf{E}_2(t) \\ &= \exp(-i\omega_1 t) [\mathbf{A}_1(t) + \mathbf{A}_2(t) \exp(-i\Delta\omega t)], \end{aligned} \quad (38)$$

where $\Delta\omega = \omega_2 - \omega_1$. The polarization matrix becomes

$$\begin{aligned} \mathbf{J}(t) &= \langle \mathbf{E}^*(t) \mathbf{E}^T(t) \rangle \\ &= \mathbf{J}^{(1)} + \mathbf{J}^{(2)} + 2\text{Re} \left[\Gamma_A^{(12)}(0) \exp(-i\Delta\omega t) \right], \end{aligned} \quad (39)$$

where Hermiticity of $\Gamma_A^{(12)}(0)$ was used. According to Eq. (19) the polarization Stokes parameters take the forms

$$S_n(t) = \text{tr}[\sigma_n \mathbf{J}(t)] \quad (40)$$

$$= S_n^{(1)} + S_n^{(2)} + 2\text{Re} \left[\mathcal{S}_{A,n}^{(12)}(0) \exp(-i\Delta\omega t) \right], \quad (41)$$

where Eq. (31) with $\tau = 0$ was employed. We also made use of the property

$$[\mathcal{S}_{A,n}^{(12)}(0)]^* = \text{tr} \left\{ \sigma_n [\Gamma_A^{(12)}(0)]^\dagger \right\}, \quad (42)$$

which can straightforwardly be verified by applying Eqs. (20) and (32)–(35). Inserting $S_{A,n}^{(12)}(0)$ from Eq. (36) into Eq. (41) leads to

$$S_n(t) = S_n^{(1)} + S_n^{(2)} + 2\sqrt{S_0^{(1)}S_0^{(2)}}|\gamma_{A,n}^{(12)}(0)| \times \cos\left\{\arg\left[\gamma_{A,n}^{(12)}(0)\right] - \Delta\omega t\right\}. \quad (43)$$

This formula can be regarded as a temporal electromagnetic interference law of two quasi-monochromatic beams with different mean frequencies. It states that any of the Stokes parameters may exhibit beating with angular frequency $\Delta\omega$ (and period $T = 2\pi/\Delta\omega$) and the beating amplitude for a certain parameter is given by the corresponding two-time Stokes parameter evaluated at equal times. Notice that the two-time parameters at different times would specify the modulation of electromagnetic temporal coherence of the superposition field. Clearly the beating effect disappears when $\Delta\omega = 0$ or the two beams are mutually incoherent in view of the degree of coherence in Eq. (37). The averages in Eq. (43) are ensemble averages and the conclusions on their validity in the description of beating are similar to those presented at the end of Section 2 for scalar fields.

Let us introduce the visibilities or contrast parameters for the beating of the Stokes parameters as

$$V_n = \frac{\max[S_n(t)] - \min[S_n(t)]}{\max[S_0(t)] + \min[S_0(t)]}, \quad n \in (0, \dots, 3), \quad (44)$$

where max and min denote the maximum and minimum value close to an instant of time t . Since the cosine term in Eq. (43) oscillates between -1 and 1, the maximum and minimum values are readily obtained leading to

$$V_n = \frac{2\sqrt{r_I}}{r_I + 1}|\gamma_{A,n}^{(12)}(0)|, \quad n \in (0, \dots, 3), \quad (45)$$

where $r_I = S_0^{(1)}/S_0^{(2)}$. If $r_I \rightarrow 0$ or $r_I \rightarrow \infty$ then $V_n \rightarrow 0$ as expected, while the maximal contrast is obtained when $r_I = 1$ corresponding to equal intensities of the waves. In the latter case

$$V_n = |\gamma_{A,n}^{(12)}(0)|, \quad n \in (0, \dots, 3). \quad (46)$$

Therefore, in terms of Eqs. (37) and (46) the equal-time electromagnetic degree of coherence can be written as

$$\gamma_{EM}^2(0) = \frac{1}{2} \sum_{n=0}^3 V_n^2. \quad (47)$$

This result demonstrates that if the equal-time electromagnetic degree of coherence between the two fields is non-zero then at least one of the contrast parameters is likewise non-zero. Consequently, either the intensity or the polarization state or both are modulated. On the other hand, modulation of at least one Stokes parameter indicates that the two fields are mutually at least partially coherent (correlated).

Eq. (47) also provides a way to measure the equal-time electromagnetic degree of coherence of two quasi-monochromatic beams. The elements of the polarization matrix and thus all four Stokes parameters and their visibilities can be measured by standard means [1] in terms of a waveplate and a polarizer resulting in the contrast parameters $V_n, n \in (0, \dots, 3)$.

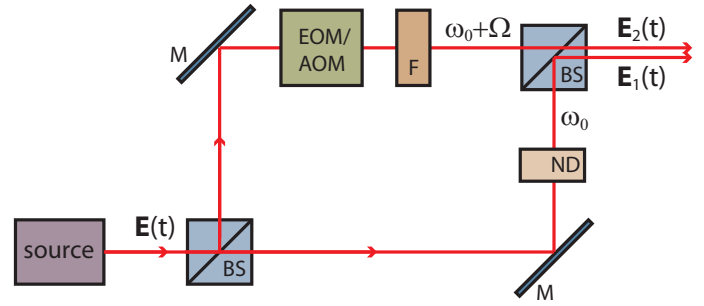

FIG. 1 Setup for generating a beam consisting of two quasi-monochromatic beams of different mean frequencies but identical polarization statistics and intensity. BS are non-polarizing beam splitters, M mirrors, EOM/AOM refer to electro-optic/acousto-optic modulator, F is spectral filter, and ND is neutral density filter.

4 SELF BEATING AND POLARIZATION MODULATION

Consider next the situation that we initially have a quasi-monochromatic, partially polarized electromagnetic beam $\mathbf{E}(t) = \mathbf{A}(t) \exp(-i\omega_0 t)$. This beam is then divided into two by a 50:50 non-polarizing beam splitter (BS) as shown in Figure 1. Next the mean frequency of the field in one arm is shifted a bit to a value $\omega_0 + \Omega$. This is achieved, e.g., by using an electro-optic modulator (EOM) to create sidebands by phase modulation or inducing a frequency shift by diffraction from a moving sound wave of an acousto-optic modulator (AOM). Typical values for Ω range from a few tens of MHz to some GHz [5] enabling an observable beating effect at optical frequencies. The modulations can be considered deterministic processes which do not alter the polarization state. The modulator arm contains also a filter (F) which transmits only the shifted frequency. In the other arm a neutral density filter (ND) is used to compensate for the loss in the modulator arm and achieve equal-intensity beams at the output of the system. The beams from the two arms are combined with another non-polarizing beam splitter. At the output of the system the beams are of the form

$$\mathbf{E}_1(t) = \frac{1}{2} \mathbf{A}(t) \exp(-i\omega_0 t), \quad (48)$$

$$\mathbf{E}_2(t) = \frac{1}{2} \mathbf{A}(t) \exp[-i(\omega_0 + \Omega)t], \quad (49)$$

where the factors 1/2 originate from the transmission through two beam splitters. Instead of Eq. (28) we now have $\Gamma_A^{(12)}(\tau) = \langle \mathbf{A}^*(t) \mathbf{A}^T(t + \tau) \rangle / 4$, which by setting $\tau = 0$ implies that $\Gamma_A^{(12)}(0) = \langle \mathbf{A}^*(t) \mathbf{A}^T(t) \rangle / 4$. The polarization matrices of the beams given in Eq. (18) are identical, $\mathbf{J}^{(1)} = \mathbf{J}^{(2)}$, and coincide with $\Gamma_A^{(12)}(0)$. It follows that the two-time Stokes parameters in Eqs. (32)–(35) with $\tau = 0$ are, in fact, the same as the polarization Stokes parameters of the beams given by Eqs. (21)–(24), explicitly $S_n^{(m)} = S_{A,n}^{(12)}(0)$ for all $n \in (0, \dots, 3)$ and for both $m \in (1, 2)$. In particular, the normalized two-time parameters of Eq. (36) with $\tau = 0$ reduce to the normalized polarization parameters in Eq. (25).

Therefore, the visibilities of the Stokes-parameter modulations in beating are determined by the normalized Stokes parameters of the beams from the two arms, i.e., $V_n = s_n^{(1)} = s_n^{(2)}$, with $n \in (0, \dots, 3)$. In addition, the normalized Stokes parameters of the two constituent fields are the same as those

of the incident quasi-monochromatic field $\mathbf{E}(t)$. We therefore find that since $V_0 = 1$ and $V_1^2 + V_2^2 + V_3^2 = P^2$, where P is the degree of polarization of the incoming beam, the visibility of the intensity modulation is in all cases unity, whereas the contrasts of the polarization modulations are characterized by the degree of polarization. In particular, if the incident beam is unpolarized no polarization beating occurs, while for a fully polarized beam strong polarization-state modulation takes place. The degree of polarization can thus be interpreted as a quantity that reflects the ability of a beam to produce polarization modulation when it interferes with itself. Analogous interpretation has previously been presented in the context of Young's interferometer where identical random electromagnetic beams are directed to the pinholes and the interference of the diffracted beams are considered close to the axis on the observation screen [9]. Here we have otherwise identical random vector beams but centered at different frequencies. The equal-time degree of coherence characterizing electromagnetic beating is with Eq. (47) found to be

$$\gamma_{EM}^2(0) = \frac{1}{2}(1 + P^2). \quad (50)$$

The minimum value $\gamma_{EM}(0) = 1/\sqrt{2}$ obtained with an unpolarized beam reflects intensity beating only. The maximum value $\gamma_{EM}(0) = 1$, found for a fully polarized beam, represents, in turn, polarization-state modulation with maximal contrasts in addition to the unit-contrast intensity variation.

5 CONCLUSIONS

We analyzed beating of stationary, quasi-monochromatic light beams both within the scalar and electromagnetic frameworks. In the former case, intensity of light exhibits periodic temporal variation with the amplitude given by the equal-time degree of coherence between the waves. In the context of electromagnetic beams we derived an interference law for two quasi-monochromatic, partially polarized fields with different mean frequencies. The interference law was expressed in terms of the Stokes parameters demonstrating explicitly that not only the intensity but also or only the polarization state may experience beating. In addition, the beating contrasts or visibilities are specified by the magnitudes of the related normalized two-time Stokes parameters (or two-point Stokes parameters at a single point) evaluated at equal times. The sum of visibilities was shown to be characterized by the equal-time electromagnetic degree of coherence between the waves. The result is analogous to those found earlier in Young's interferometer [8] or in Michelson's interferometer [10]. When the random electromagnetic beams are identical replicas of each other but with different carrier frequencies, the strength of polarization modulation was found to be given by the degree of polarization of the waves. This is consistent with a recent interferometric interpretation of the degree of polarization [9]. The theoretical description of optical beating presented in this work holds for the waves whose coherence times are much shorter than the beating period. In the opposite case, transient temporal fringes are encountered. Finally, we point out that in practice, frequency shifters are required to produce correlated stationary waves, whereas for non-

stationary light with (partially) correlated frequencies, beating can be observed between narrow spectral peaks obtained by filtering.

6 ACKNOWLEDGEMENTS

This work was partially funded by the Academy of Finland (project 268705) and by Dean's special support for coherence research at the University of Eastern Finland, Joensuu (project 930350).

References

- [1] L. Mandel, and E. Wolf, *Optical coherence and quantum optics* (Cambridge University Press, Cambridge, 1995).
- [2] J. W. Goodman, *Statistical optics* (Wiley, New York, 2000).
- [3] C. Brosseau, *Fundamentals of polarized light: a statistical optics approach* (Wiley, New York, 1998).
- [4] A. Dogariu, and E. Wolf, "Coherence theory of pairs of correlated wave fields," *J. Mod. Opt.* **50**, 1791-1796 (2003).
- [5] B. E. A. Saleh, and M. C. Teich, *Fundamentals of photonics* (second edition, Wiley, Hoboken, 2007).
- [6] J. Tervo, T. Setälä, and A. T. Friberg, "Degree of coherence for electromagnetic fields," *Opt. Express* **11**, 1138-1143 (2003).
- [7] T. Setälä, J. Tervo, and A. T. Friberg, "Complete electromagnetic coherence in the space-frequency domain," *Opt. Lett.* **29**, 328-330 (2004).
- [8] T. Setälä, J. Tervo, and A. T. Friberg, "Contrasts of Stokes parameters in Young's interference experiment and electromagnetic degree of coherence," *Opt. Lett.* **31**, 2669-2671 (2006).
- [9] L.-P. Leppänen, K. Saastamoinen, A. T. Friberg, and T. Setälä, "Interferometric interpretation for the degree of polarization of classical optical beams," *New J. Phys.* **16**, 113059 (2014).
- [10] L.-P. Leppänen, A. T. Friberg, and T. Setälä, "Temporal electromagnetic degree of coherence and Stokes-parameter modulations in Michelson's interferometer," *Appl. Phys. B* **122**, 32 (2016).
- [11] L. Mandel, and E. Wolf, "Coherence properties of optical fields," *Rev. Mod. Phys.* **37**, 231-287 (1965).
- [12] A. T. Forrester, R. A. Gudmundsen, and P. O. Johnson, "Photoelectric mixing of incoherent light," *Phys. Rev.* **99**, 1691-1700 (1955).
- [13] A. Javan, E. A. Ballik, and W. L. Bond, "Frequency characteristics of a continuous-wave He-Ne optical maser," *J. Opt. Soc. Am.* **52**, 96-98 (1962).
- [14] G. Magyar, and L. Mandel, "Interference fringes produced by superposition of two independent maser light beams," *Nature* **198**, 255-256 (1963).
- [15] A. Shevchenko, M. Roussey, A. T. Friberg, and T. Setälä, "Ultra-short coherence times in partially polarized stationary optical beams measured by two-photon absorption," *Opt. Express* **23**, 31274-31285 (2015).
- [16] O. Korotkova, and E. Wolf, "Generalized Stokes parameters of random electromagnetic beams," *Opt. Lett.* **30**, 198-200 (2005).
- [17] J. Tervo, T. Setälä, A. Roueff, Ph. Réfrégier, and A. T. Friberg, "Two-point Stokes parameters: interpretation and properties," *Opt. Lett.* **34**, 3074-3076 (2009).

- [18] G. Basso, L. Oliveira, and I. Vidal, "Complete characterization of partially coherent and partially polarized optical fields," *Opt. Lett.* **39**, 1220–1222 (2014).
- [19] T. Setälä, J. Tervo, and A. T. Friberg, "Theorems on complete electromagnetic coherence in the space-time domain," *Opt. Commun.* **238**, 229–236 (2004).