

TECHNICAL ASPECTS ON DYNAMIC BEHAVIOR OF THE SEMITRAILERS WITH SUSPENSION HITCH

NEDELICU A.¹⁾, CIUPERCA R.¹⁾, POPA L.¹⁾, ZAICA A.¹⁾, LAZAR G.¹⁾
TEFAN V.¹⁾, PETCU A.,

¹⁾INMA Bucharest;

E-mail: nedelcu.ancuta@yahoo.com

Keywords: agricultural semitrailers, hitch with suspension, vibration,

ABSTRACT

An efficient means of transport, over short distances and heavy-duty traction on roads maintained or unmaintained field, agricultural land is considered system tractor - trailer. This article presents the results of experimental research on the dynamic behavior of the system tractor - trailer suspension system provided with agricultural roaster. The variety of constructive solutions for hitches with suspension motivated interest in experimental research of the effects caused by the introduction of elastic elements (leaf springs), on farm semitrailer. They studied three variants of hitches compared with suspension and without suspension version. To highlight how it influenced the dynamic behavior of the studied system, were determined and analyzed for the following parameters: its spectrum of frequencies, maximum amplitude of vertical acceleration root mean square of the accelerations respectively.

INTRODUCTION

In agriculture, is transported large quantities of goods and materials. Agricultural transport is a main component of the agricultural production process aimed at moving materials and products rather than amending their physico-mechanical properties. Transportation equipment used in agriculture as energy source is classified into two categories: auto propelled transport means (vehicles with own transport platform) and transport trailed (trailers and semi-trailers). [5, 7].

Power increases and the need to manufacture tractors appeared appropriate their trailers.

In recent years we have seen spectacular diversification in agricultural semi-trailers constructively and increase transport capacity up to 30 t.

This was due, in large part, the advantages that are gained by using semi-trailers compared with two-axle trailers: tare ratio increased; handling and good ride; simpler construction; price lower cost; fuel economy, etc. Also characteristic is that the trailer hitch transferred by a significant part of its weight and thus traction device of the rear axle of the tractor, increasing its adherent weight, and therefore the traction force.

However, because of this link: shock, vibration and dynamic loads resulting, in particular, due to the action of the vertical force component of interaction between the wheels and the road, which is considered a drawback to be reduced or even removed are transmitted to the tractor. [3,10]

To reduce these drawbacks, especially for the comfort, acted in several directions: improving suspension tractor seat, improved suspension axles on semitrailers, and introducing a system of suspension with leaf springs on semitrailer. [1, 2, 6, 8]

The diversity of existing constructive solutions for hitch with suspension of high-capacity semi-agricultural, prompted conducting theoretical and experimental research on the dynamic behavior of the system tractor - trailer equipped with suspension roaster. [4, 9].

MATERIAL AND METHOD

Of the many constructive solutions existing and analyzed there have been chosen for the research, those that stood by simple technical solutions, and representative of that type, and easily assimilated into production series. Thus, they designed, built and tested in four different working conditions hitches:

- I - hitch without suspension (rigid drawbar symbolized PR);
- II - suspension hitch with longitudinally mounted under the frame (symbolized PSLA, fig. 1);
- III - mounted hitch suspension with transverse (symbolized PST, fig. 2);
- IV - spit with suspension mounted longitudinally in front frame (symbolized PSLR, fig. 3).

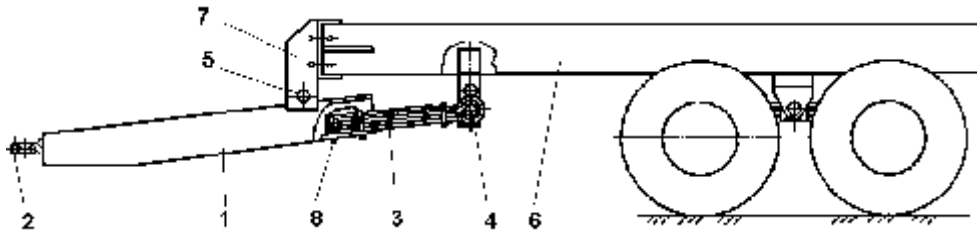

Fig. 1. Hitch with the suspension longitudinally set under the gripping device (PSLA):
 1 - hitch; 2 - tow-rope hoop; 3 - leaf type spring; 4 - elements for fixing the chassis spring; 5 - spring bolt; 6 - chassis; 7 - hitch support; 8 - elements for fixing the spring to the hitch;

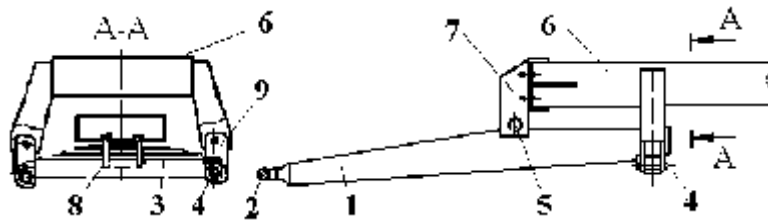

Fig. 2 Hitch with the suspension transversally set (PST):
 1 - hitch; 2 - tow-rope hoop; 3 - leaf type spring; 4 - elements for fixing the chassis spring; 5 - spring bolt; 6 - chassis; 7 - hitch support; 8 - elements for fixing the spring; 9 - support

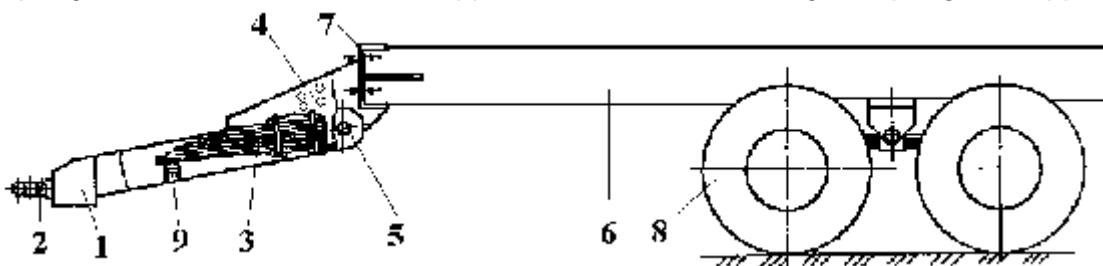

Fig. 3. Hitch with the suspension longitudinally set in front of the gripping device (PSLR):
 1 - welded hitch; 2 - tow-rope hoop; 3 - leaf type spring; 4 - body for connection and adjustment; 5 - spring bolt; 6 - chassis; 7 - hitch support; 8 - wheels; 9 - bearing cross rail of the spring

To study the effects of vibration occurring in aggregate real working conditions, were carried out tests that required assembly and the necessary equipment. located in the diagram of Figure 4.

For conducting experiments worked in the system U 650 wheeled tractor and equipment used technique for performing measurements and special registration: DAP data acquisition system for 2400, laptop, inductive type accelerometers B12 / 200-

company Hottinger; Analog Devices 3B20-type amplifier-company Hottinger; U650 tractor beam voltage, cod.DFT-65.0, which are mounted strain gauges; specialized programs for processing: MATHCAD; nSOFT, MATLAB.

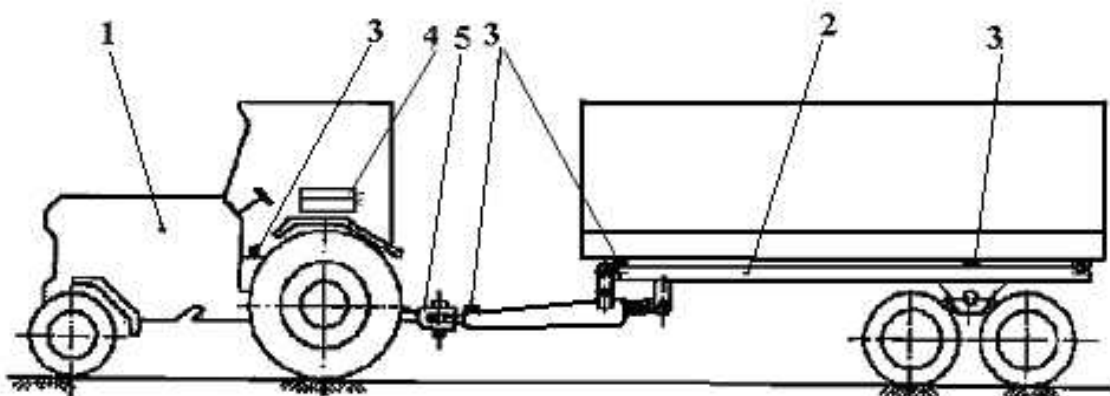

Fig.4. Scheme of the system and placing of the technical device necessary for recording the terrain signals:

1 – wheeled tractors U 650 M (power of 65 CP); 2 – semi-trailer (total mass 9300 kg); 3 – acceleration transducers; 4 – acquisition and signal processing device; 5 – transducer for measuring the traction force.

The testing of every type of aggregate tractor-semi-trailer has been carried out under similar conditions, upon two types of road (concrete and earth road) with values of the irregularities height h_0 and of the irregularities length (step) L within the limits offered in Table 1.

Table 1

Characteristics of the irregularities of the experimental roads

Road type	h_0	L
	[mm]	[m]
Concrete road	10...20	3...5
Earth road	20...30	0.15...0.3

RESULTS AND DISCUSSIONS

In the framework of the experimental research there have been effected 28 experiments during which there have been realized recordings with the sampling frequency of 500 Hz.

The results of the signal processing obtained within the effected tests are centrally presented in the tables 2 ... 5, the significance of the notations being as follows:

t_{max} , RMS_{zt} - maximal amplitude of the vertical acceleration, measured at the tractor floor and, respectively, the average square root of these accelerations;

p_{max} , RMS_{zp} – maximal amplitude of the vertical acceleration, measured on the hitch and, respectively, the average square root of these accelerations;

rf_{max} , RMS_{zrf} – maximal amplitude of the vertical acceleration, measured at the front transverse cross bar and, respectively the average square root of these accelerations;

rs_{max} , RMS_{zrs} – maximal amplitude of the vertical acceleration, measured at the back transverse cross bar and, respectively, the average square root of these accelerations;

Table 2

Performances of the aggregate tractor + semi-trailer in the PR variant

Road type	Speed [km/h]	<i>Parameters</i>							
		$\ddot{z}_t \text{ max}$ mm/s ²	RMS_{zt} mm/s ²	$\ddot{z}_p \text{ max}$ mm/s ²	RMS_{zp} mm/s	$\ddot{z}_{rf} \text{ max}$ mm/s ²	RMS_{zrf} mm/s ²	$\ddot{z}_{rs} \text{ max}$ mm/s ²	RMS_{zrs} mm/s ²
Concrete road	11.8	6.16	2.176	4.12	0.996	6.73	1.218	0.93	0.294
	11.8*	5.08	2.056	3.62	0.895	30.75	1.123	1.03	0,364
	23.0	7.52	2.386	6.22	1.524	5.78	2.136	0.91	0.348
	16.9*	5.44	2.045	3.96	1.141	4.6	1.365	1.02	0.327
Earth road	10.9	6.59	2.037	4.54	0.919	4.57	1.273	1.03	0.397
	8.5	4.76	1.997	4.7	0.72	4.05	0.876	0.79	0.326
	7.0	4.31	1.920	2.88	0.688	2.31	0.761	0.75	0.307

* braking

Table 3

Performances of the aggregate tractor + semi-trailer in the PSLA variant

Road type	Speed [km/h]	<i>Parameters</i>							
		$\ddot{z}_t \text{ max}$ mm/s ²	RMS_{zt} mm/s ²	$\ddot{z}_p \text{ max}$ mm/s ²	RMS_{zp} mm/s	$\ddot{z}_{rf} \text{ max}$ mm/s ²	RMS_{zrf} mm/s ²	$\ddot{z}_{rs} \text{ max}$ mm/s ²	RMS_{zrs} mm/s ²
Concrete road	12.1	6.41	2.187	7.96	2.948	4.89	1.013	0.52	0.34
	11.7*	4.91	2.087	7.72	3.42	2.79	0.894	0.67	0.228
	23.3	7.77	2.263	12.98	4.515	5.24	1.456	0.72	0.24
	17.3*	5.45	2.215	11.06	3.8	3.98	1.365	0.54	0.272
Earth road	11.3	4.42	1.912	7.96	3.27	2.99	0.937	0.7	0.223
	8.7	4.88	1.933	9.46	3.469	2.22	0.746	0.64	0.356
	7.9*	4.15	1.918	8.72	3.69	2.03	0.657	0.93	0.204

* braking

Table 4

Performances of the aggregate tractor + semi-trailer in the PST variant

Road type	Speed [km/h]	<i>Parameters</i>							
		$\ddot{z}_t \text{ max}$ mm/s ²	RMS_{zt} mm/s ²	$\ddot{z}_p \text{ max}$ mm/s ²	RMS_{zp} mm/s	$\ddot{z}_{rf} \text{ max}$ mm/s ²	RMS_{zrf} mm/s ²	$\ddot{z}_{rs} \text{ max}$ mm/s ²	RMS_{zrs} mm/s ²
Concrete road	12	6.40	2.285	9.04	3.639	5.6	0.988	0.76	0.280
	11.9*	4.95	2.175	8.54	3.745	3.12	0.92	1.31	0.825
	25.0	7.85	2.751	12.14	3.727	5.15	1.809	0.32	0.482
	16.6*	6.12	2.335	12.22	4.047	4.49	1.553	0.29	0.479
Earth road	11.5	5.88	2.14	8.88	3.441	3.7	1.103	0.74	0.298
	9.5	5.12	2.086	7.12	3.336	2.8	0.782	1.02	0.327
	8.2	4.58	1.978	6.8	3.019	1.84	0.6	0.68	0.185

* braking

Analysis of the dynamic behavior of each type of aggregate was made by comparing the values obtained for each parameter studied. The procedure consisted in giving percentage points and dynamic performance achieved, the results were pooled and results the following ranking:

- first prize with 28.79%, + semitrailer tractor hitch unit type PSLA;
- Second place with 24.24% + semitrailer tractor hitch unit PST;
- Third place with 23.48% aggregates formed by tractor + semitrailer variants rigid hitch PSLR and PR.

Table 5 presented frequency spectrum selected from entries, and assigned to four experimental versions :

Table 5

Own frequency spectrum of the four variants tested

Variant hitch	Spectrum own experimentally determined [Hz]
Rigid hitch , PR	1.67; 2.45; 2.9; 5.2
Hitch with suspension mounted transversely PST	1.67; 2.2; 2.8; 5.7
Hitch with longitudinally mounted suspension under the semi-trailer chassis, type psla	1.63; 2.2; 2.9; 4.35
Hitch with suspension mounted longitudinally in front of the chassis, type DSLR	1.6; 2.6; 2.9; 4.6

It has also been found that the spectrum all signals contain high frequencies of 50 to 65 Hz, derived from the fluctuations caused by the transmission of the tractor, a packet of frequencies around 33 Hz, the frequency coming from the engine and generally one two frequencies of 27 Hz around, coming all the organs tractor ride.

By comparison with the results of [3], Volume 3, the oscillation of the sprung mass of the trailer is properly located somewhere in the range 3 to 5 Hz, the tractor provides bob and pitch frequencies somewhere between 2 and 4 Hz. Therefore its spectrum selected spectra is consistent with the same kind of machinery, published in the literature.

Also after [3], the frequencies determined from experimental records fit perfectly within corresponding frequency range of agricultural tractors and trucks and the corresponding frequency range of vehicles with tires earth moving.

CONCLUSIONS

-Apart from the testing variants on concrete road at high speed moving along (when the moving along speed during the tests was characterized by different values), there has been effected a statistic analysis of the performances of the four types of aggregates tractor-semi-trailer which have been experimented (3 aggregates with semi-trailers with elastic hitch, in the mentioned variants, and an aggregate with rigid hitch).

-The analysis of the dynamic behavior of each type of aggregate has been accomplished by comparing the values obtained for the studied parameters, according grades (points) for the studied dynamic performances. This way, for the aggregate whose parameter value indicates a disadvantageous situation there has been granted a single point, and for the other aggregates there have been granted, comparatively, up to 4 points.

-The statistics resulted from the even-leveled average of all hierarchies has enhanced that the best performances (that is a better dynamic behavior for most parameters) have been obtained for the hitch with the suspension longitudinally set under the chassis of the semi-trailer, type PSLA (fig. 1), followed by the hitch variant with the suspension transversally set under the chassis of the semi-trailer, type PST (fig. 2). On the last places there has been classified the hitch with the suspension longitudinally set in front of the gripping device type PSLR (fig. 3) and the rigid hitch (with no suspension).

-It is also to be noted that not any chosen elastic connection (setup variant, type and rigidity of the spring) for the suspension hitch improves the performances of the aggregate, there existing the possibility for the functional characteristics of the system to deteriorate in case of an inadequate choice.

-The semitrailers are used in combination with agricultural tractors for transport systems, due to their smaller constructive weight and total length compared to trailers, and particularly due to their positive influence on transport and braking dynamics. This

influence is achieved by the contribution to increasing the tractor adhesion load, consequently to the transfer of a part of the semitrailer weight upon the tractor. The semitrailer, having only one axle, has as a second supporting point the coupling devices of the tractor, located at the inferior part of the tractor rear.

-In order to reduce the shortcoming determined by the vibrations and shocks transmitted by semitrailer to tractor it aims at improving the suspension system at tractor seat and trailer's axles level and in the same time particular constructive solutions for semitrailers with a suspension system at the hitch.

BIBLIOGRAPHY

- [1] **Bodea C., Căndea I., Popescu S.**, 2008, *Studies and Researches Regarding the Street-Traffic Security of the Tractor-Trailer Aggregate and of The Agricultural Equipments/* Scientific Papers INMATEH- Alternative Energies, Mechanizing Technologies and Efficient Technical Equipment for Agriculture And Food Industry contents no.. 26,p. 72-76, Nr. 3 /2008,
- [2] **Căndea I., Bodea C., Bria N., Andrei I.**, 2008, *The Kinematic And Dynamic Analysis Of The Spheric Couple As Coupling Organ Between The Tractor And The Semitrailer* , Scientific Papers INMATEH- Alternative Energies, Mechanizing Technologies and Efficient Technical Equipment for Agriculture And Food Industry Contents no.. 26,, p.77-82, ISSN 1583-1019.
- [3] **Cyril M. Harris, Charles E. Crede**, 1969, *Shocks and vibrations*, Technical Publishing House, Bucharest
- [4] **Dima I.**, 2000, *Contributions to study of vibrations of subassemblies of agricultural machinery*, PhD-Thesis, University Politehnica, Bucharest / Romania
- [5] **Dragutan V. Demetrescu I.** 1984, *Mechanization of transport in agriculture*, Ceres Publishing House, Bucharest
- [6] **Ionel Andrei, Ioan Căndea, Nicolae Bria** , 2009, *Kinetic-Dynamic Analysis of the Farm Tractor & Twin-Axle Trailer Combination in Various Mechanical States*, Scientific Papers INMATEH, Contents no 28, Nr. 2/2009, p. 4-7, ISSN 1583-1019
- [7] **Francisc C. Ciuperc R.**, 1997, *Considerations about modern agricultural transport*, Scientific Papers, INMA Bucharest
- [8]. **Mocanu V., Hermenean I.**, (2010) *Experimental Researches Concerning Dynamics and Energetics of Two-Wheel Tractor - Semitrailer Systems*, INMATEH- Agricultural Engineering, Contents no 32, Nr. 3/2010, p. 59-64, e: ISSN 2068-2239, p ISSN 2068-4215.
- [9]. **Nedelcu A.**, 2008, *Suspension systems for agricultural trailers*, Terra Nostra Publishing House, ISBN 978-973-8432-93-2.
- [10]. **andru A. et all.**, 1983 „ *Exploiting farm machinery*” Publisher Didactic and pedagogic, Bucharest.