

CONSIDERATIONS ON THE EXTRACTION TECHNOLOGY OF SUGAR SORGHUM JUICE

OPRESCU R.¹⁾, VOICEA I.¹⁾, VLĂDUȚ V., GĂGEANU I.¹⁾, CUJBESCU D.¹⁾, PERSU C.¹⁾, IUGA D.¹⁾, BIRIȘ S.Ș.T.²⁾, DUMÎTRU I.¹⁾, STROESCU GH.¹⁾, POPA L.-D.³⁾, BORUZ S.⁴⁾

¹⁾INMA Bucharest / Romania; ²⁾P.U. Bucharest / Romania, ³⁾SCDA Secuieni / Romania;

⁴⁾University of Craiova / Romania

E-mail: oprescu.remusmaris@gmail.com

Keywords: *sugar sorghum extraction technology, juice*

ABSTRACT

Lately there has been an increase in drought periods but also an increase in population and therefore in consumption of food and fuel while arable land remains the same which leads to the cultivation of species with high energy potential and high nutritional potential as drought

resistant, species of sorghum. The sorghum is used for: food (flours, juices, syrups, vinegar, etc.), for animal feed, but also in the industry for fuel, energy, building materials, paper, proposes to carry out an analysis of the technologies for obtaining juice from sorghum.

INTRODUCTION

The economic importance of sorghum is quite significant given that 16% of the total cereal consumption in the world is represented by sorghum. In developed agricultural countries, sorghum represents about 25% of total cereals, with world grain production rising over 50% since 1960 (in the US, wheat and maize, grain is the most important cereal). Globally, sorghum is the fourth grain crop as a territorial extension, productivity and utility, its importance also deriving from its exceptional resistance to dryness caused by stress. On the other hand, sorghum is more tolerant to stress caused by floods than maize, but to shorter floods. Sorghum can be a good opportunity for lowland areas with a poorer soil, affected by heat and drought. [7]

In addition to the cultivars of sorghum cultivated for seed production, it is of particular importance the sugar sorghum grown for the production of sweet substances from its stems. He is known under various names: Dumac, early amber, amber 576, amber red, orange 450, Nancy, columan, calian, gaolian, etc. It was originally grown in Asia and Africa along with sugar cane to obtain sweet

substances. In the US, the sweet sorghum was introduced to culture in 1854 by bringing it from South Africa. Successive improvements have made it possible to obtain varieties that give a good quality syrup.

In Europe, the largest tradition in sorghum cultivation and the use of juice obtained by squeezing is Italy. During the Second World War the main direction of use was the production of ethyl alcohol, which was used as aviation fuel (20% alcohol and 80% gasoline) with petrol, [5]. Currently, it is grown on large areas in the Far East, USA, Russia, France, Italy, Hungary, etc.

In Romania it is not known exactly when this plant was brought and cultivated. The literature mentions that in 1936 "one hectare was cultivated with Gaolian in four kinds of land and in all it succeeded". During the Second World War, the plant is cultivated in the areas of Bessarabia, Dobrogea, Prahova, Danube Plain and Banat. It develops on medium-textured soils.

The sorghum meets favorable conditions of culture in Romania in the areas covered by isotherms of 20 - 22 ° C for the summer months. Preferred

sorghum soils are those deep-neutral, neutral or alkaline reaction. On compact, cold or underground ground water, yields are diminished.

The sorghum must not be absent from the sanding, alkalized and salinized soils, or on the sloping land, for its high adaptability to drought (sweat coefficient = 158-274), alkalinity (pH = 5 - 9), and the salinity of the soil or the prevention of deflation on sandy soils [2, 3].

The zoning of hybrids and varieties is based on the number of freeze-dried days,

soil and climate particularities during the growing season, as well as on the properties of hybrids and varieties to adapt to specific ecological conditions and to the requirements of growers or processors.

In sugar sorghum, Roza and Doina hybrids are recommended in zones I and II of favoritism both for the production of syrup, vinegar and food alcohol as well as for the production of silos intended for animal feed. Doina hybrid beans can be used in pig and poultry feed due to low tannin content.

MATERIAL AND METHOD

Sorghum sugar is a herbage that reaches 2 m or more. It is to be developed as a multi-purpose food

product (fuel, fodder and fiber crops); also has medicinal properties. It is resistant to drought and salt soil.



Fig.1 - Plantation sequence



Fig.2 - Sugar sorghum harvester sorghum [1]

The quality of the sweet sorghum and the juice obtained from it depends to a large extent on the time of harvesting. Cultures of sorghum intended for the production of juice must be harvested when the maximum amount of sugars in the plant is found with the highest percentage of sucrose. As the degree of maturity of the plant advances, the overall sugar content increases and the ratio of reducing sugars changes; their inappropriate proportion can adversely affect the quality of the syrup. Generally, harvesting the sucrose juice is done when the grains are already mature. The whole plant is used to extract the juice after the panicles have been harvested at the last

internode. Removing panicles with the last internode is mechanistically feasible and is necessary because they contain very little sugar and some salts that impart a bad taste to the juice. It is advisable for the stems to be cut as close as possible to the ground, since the lower internodes contain the largest amount of juice.

The harvest of sugar for the production of syrup and sugar is mechanized. For this purpose, in the first phase, seed panicles are harvested and transported to the drying centers. When the grain humidity reached 13-14%, they are threshed, then passed through the cleaning machines and then stored. After harvesting panicles, mechanized strains

are harvested. The material resulting from the split green cut harvester (cut) is transported to the crushing and pressing plant to obtain the juice. After pressing, the cabbage is transported to livestock farms for the purpose of foddering bovine animals in the form of a green meal or for silage for winter fodder. The silo obtained is a good quality feed being generally given to cattle and especially to dairy cows.

The harvest starts at the humidity of the grains of 15% in dry autumn and 16-18% in wet autumn, in order to accelerate the drying of the grapes in the foreseeable autumn, Roundup desiccant treatments (6 l commercial product dissolved in 150 l water / ha, applied when the grains had 30-35% moisture) for harvest at 14-16 days after treatment.

The same combines are used as for grain cereals with the following adjustments: drum speed of 600 - 800 rpm, the contractor opening will be 4 -5 crank strokes from the fully closed position, the adjustable mesh opening, moderate or maximum, semi-open ventilation, the fixed sieve will have holes of 7 - 8 mm. Entry into the rope will be done after dew. The chain speed of the combine will be adjusted according to the chain density. In the first phase the panicles are harvested with seeds, so that in the second phase the stalks are harvested. The resulting material (s) is stored in a hopper where it will then be transported to the storage site or the crushing and pressing plant to obtain the juice.

RESULTS AND DISCUSSIONS

Large sorghum production has been found to mean a very large quantity of green sorghum (80 - 100 t / ha) that must be processed and handled both before

and after squeezing. The sorghum is easily obtained on the farm so that the production it only requires simple press and some processing equipment.

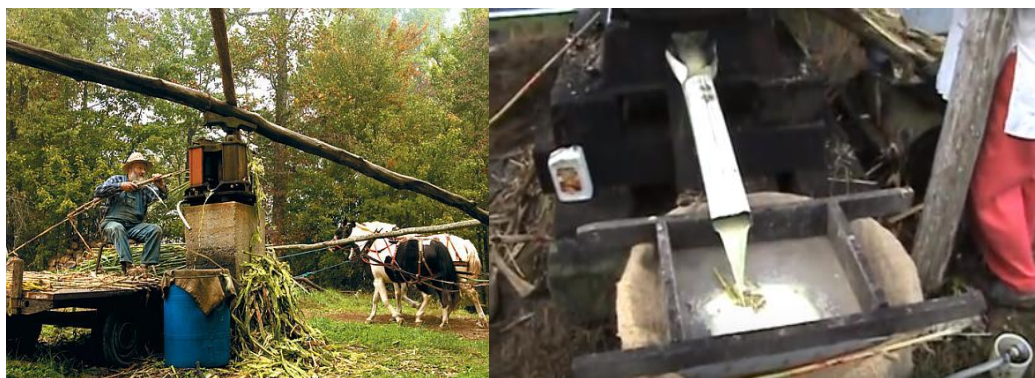

Fig.3 - Installation of sorghum syrup product on a US farm and sold in health food stores

To process large products, it is necessary to produce a machine with high squeezing capacity, which is an element of a technological line for the processing of sugar sorghum strains. Such a plant made up of squeezing machines and the associated equipment is the subject of a juice extraction station capable of providing at a constant rate to some food or chemical industry users. This must be

fed with green meal harvested from farmland located at close distances. It should be noted, however, that large amounts of green squeezed mass are produced at the station, which in turn must be evacuated in order not to block the squeegee and, implicitly, the whole station.

Figure 4 is a schematic diagram of a juice sorghum juice production station principle.

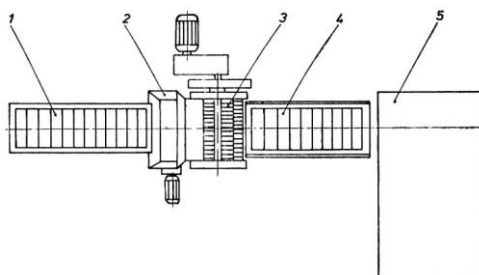

Fig. 4 - The basic technological scheme of the juice-making station in sugar

1 - stem reception system; 2 - the hopper feed hopper; 3 - the equipment for sowing sugar sorghum strains; 4 - Exhaust conveyor; 5 - the green table squeeze storage platform

The main data underlying the design of the squeezing machine for sugar sorghum refers to the production capacity expected to be 5 - 6 tons of green weight per hour and some properties of the sorghum strains such as its morphological structure and behavior during press.

The sorghum juice extraction stations are recommended to be located in the center of the cultivation basin, meaning both the topographical position or the status of the access routes from the production plots to the station, as well as the provision of electricity, running water and rational evacuation possibilities extracted juice and squeezed green mass. The collector basin, which is a technological annex to it, due to its relatively small capacity, requires a continuous evacuation in a short-term storage and preservation buffer, from where the juice is transported in suitable means of transport (car tanks) and then shipped to industrialization units.

At the station, it is necessary to arrange a system for receiving the chopped stalks (figure 4, item 1) brought by the appropriate vehicles from the crop. The capacity of the receiving system correlates with the capacity of the squeeze machine in such a way as to allow its continuous operation between successive shipments. The receiving system of chopped material must allow uniform feeding of the squeeze machine either directly by spraying the blade into the hopper hopper or by means of a conveyor, preferably with a strip, suitably located between the receiving system and the hopper hopper.

With regard to the green mass reception system, it may differ from case to case. In the case of the use of other sorghum straw harvesters than those delivering the shredded green meal transported as mentioned, from the cork to the station reception system and then led to the sowing machine hopper, the preparation of strains for squeezing takes place at the station. In this way the strains are brought from the field with appropriate transport means, are discharged into the station, and according to the necessity of the intended purpose will be prepared directly, or defoliated or decapitated by the panic, followed by the straining process of the strains, the sight of the squeeze, then take place. Due to the amount of juice remaining in the squeezed mass, it is obviously necessary to transport it as efficiently as possible for efficient use by lactic fermentation.

Replacement in good condition of crystallization of sugar, contained in the juice extracted from a green mass deposited over a longer period, is done with considerable material expenses, which obviously leads to a decrease in the profitability of the process. Due to the agro-technical conditions, it may occur after a shorter or longer time, the need to change the culture of sorghum from certain lands or even the entire pool located around a juice extraction station. In this case, the whole station must be re-positioned. Such an operation may raise particular problems, arguing the necessity of both dismantling the machinery, transporting it and rebuilding the site of the old site.

We believe that a solid but lightweight foundation is best suited to the squeegee, given the possibility of re-stationing. The juice extractor must also include a lifting equipment, capable of serving all heavy duty machinery, in particular the roller. The presence of such equipment is absolutely necessary, both for the initial installation of the equipment and for occasional interventions or revisions.

When determining the construction solution for the squeeze machine, account was taken of the structural properties of the sweet sorghum strain. It consists of an array of knots and internodes throughout its length, from root to panic. The structure of the internodes consists of a fibrous network comprising cells in its interstices in which the juice is located. The evacuation of the juice from this structure is a process of flow through the porous medium. The drainage of juice from the table to be squeezed takes place at a certain speed. In order to make the slicing process effective, it follows that the passage of the mass of chopped stalks between the rollers, that is to say, the part over which the pressing action is carried out within the machine, must be carried out at an optimal speed of less than the draining speed of the juice through the fibrous web of chopped strains.

In order to bring about the phenomenon of the release of the juice from the strains, it is obviously necessary to destroy as far as possible the cross-linking structure of the strains. In order to ease the drainage effect of the juice from the stem network and between the strains in the squeezing area, the length of the longitudinal inner channels through which the flow occurs should be as short as possible. So the juice quickly comes out of the intimate stem structure, flowing into the collecting tank of the squeeze machine.

Such a hydraulic flow phenomenon from the inner ducts of the strain on a longer route is undesirable because it brings with it an unnecessary increase in the strain resistance of the rollers between the rollers and consequently a proportional increase in the power required to drive the machine. At the same time too much shredding of the stems to values of lengths less than 4 or 5 times their cross-sectional dimension is also disadvantageous because of the too fast passage through the high pressure zone, during which drainage can not take place, and the squeeze process is carried out with very low yield. In fig. 5 is schematically depicted how drainage of sorghum juice takes place during the passage of the green mass among the rollers.

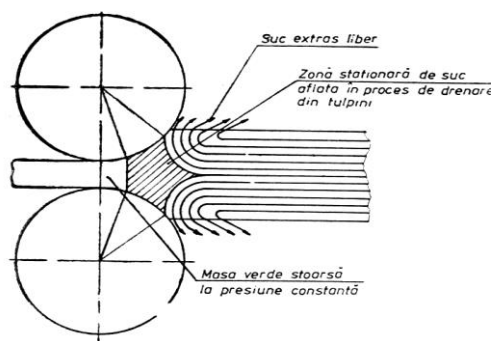

Fig. 5 Scheme of the juice drainage process

It is noted that the massive extraction of juice from the chopped stalk mass takes place before they penetrate between the rollers. The flow of juice extracted from the stems opposes an additional resistance to that required by compressing them between the rollers. In fact, the main stress occurs as a result of the hydraulic pressure exerted by

the free-flowing juice, which can not penetrate the rollers, is forced as long as the straws pass in the passage to longitudinally pass the strain to be gravitationally discharged into the juice jug below the level of the rollers. The machine is designed as a system of three rollers positioned horizontally within a metal frame as shown in Figure 6.

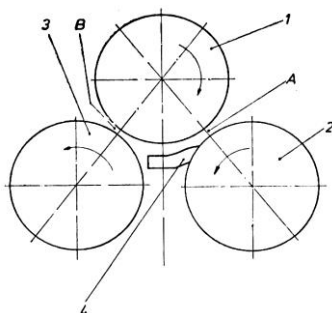

Fig. 6 - The construction principle of the juice sorghum juice extractor

1 - upper roller; 2 - lower entry roller; 3 - lower discharge roller; 4 - driving track
A - the passage I to the right; B - the second squeeze passage

The skeleton of the machine is of special design. For ease of assembly and interventions it is designed to be articulated from welded cemented elements, of a special type, which allow the release of bearings and rollers for the purpose of extracting them in case of need. Another difference between the old press systems and the modern system is the circular groove of the rollers against the longitudinal rift on their outer surfaces in the old system. The circular cannula has the advantage that it makes it possible to use workbenches for combing the combs of the rollers that intersect with their grooves; at the same time, contributes to increasing the efficiency of juice drainage from the green sorghum mass.

In order to improve the juice extraction effect, the new machine is equipped with a crushing unit for pieces of sorghum straws. It is made up of two smaller-sized rollers mounted in its own skeleton, located at a higher level than the entrance to the first passage of the machine itself, the crossing passage. The two crushers of the crushing device are also provided with interlocking circular grooves. In order to improve the adherence of these crushing rollers to the green mass of sorghum stalks, there are further applied helical grooves on the roller grooves which, during operation, exert a action of pulling the green mass and driving it through the feed channel of the first passage from the squeeze machine. The basic structure of the new machine is shown in Figure 7.

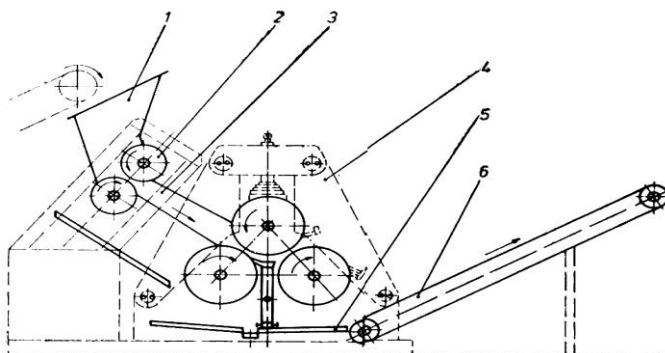

Fig. 7 - The basic structure of the juice sorghum juice extraction machine

1 - green table feed hopper; 2 - the crusher with two grooved rollers; 3 - the green feed channel of the squeeze machine; 4 - the three-roller squeeze machine; 5 - juice collector basin; 6 - Exhaust transport for the squeezed green table

The juice extracted from the two passages is collected in the lower bottom basin. Due to the low capacity of this collection tank, the juice requires continuous dripping into a high-capacity buffer tank from where it can be loaded into transport

means, by road, rail or river transport, as appropriate, in order to be efficiently transported to the industrialization.

The green mass squeezed in the second passage is discharged by a belt conveyor having the role of extractor. The

evacuation must take place continuously and at the same rate as the feed.

It should be noted that the green mass to be squeezed must be free of foreign bodies, especially metallic. The penetration of such foreign bodies into the passages of the rollers leads to serious damage to their active surface or damage to the entire machine. In order to obtain a good yield of the squeeze process, the green mass supply must be uniform and at nominal capacity. In the case of feeding the hopper with a green mass minced by means of an inclined conveyor, it must permanently discharge material that does not contain whole stalks because it is disposed in the hopper, facilitates the formation of the vaults and interruption of the supply, requiring interventions by the personnel service.

In the case of feeding the hopper directly from the straw shredder, which is so

arranged that the jet of cut stems will hit directly in the hopper, it is necessary to feed the shredding aggregate continuously and at the capacity. This feed operation must necessarily be mechanized for both feeding the chopper and then the conveyor to the hopper.

The quality of the preparation of the sorghum strains also has a large share in the performance of the aggregate. As shown above, the fibrous structure of the strain should be as completely decomposed as possible. To a great extent, this process takes place within the crusher, which is an integral part of the squeegee. The machine allows for the squeezing of defoliated sorghum strains, decapitated by panic or non-frozen, depending on the destination and the qualities imposed on the juice.

In fig. 8 we have two types of presses used to crush sour stems to obtain juice.

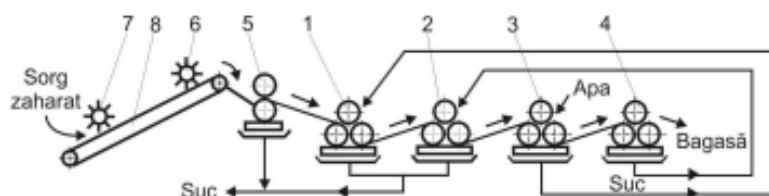

Fig. 7 - Scheme of the technological line for squeezing the juice from the sorghum strains, [1]

1,2,3,4-roller presses; 5-crusher; 6-chopper; 7-vane leveler; 8-conveyor



Fig. 8 - Crusher for crushing sorghum strains



Fig.9 - Technological line for squeezing sugar sorghum [1]

a) the receipt of fractions; b) the distribution; c) feeding; d) the determination; e) squeezing the juice; f) evacuation of bagasse

CONCLUSIONS

The sorghum has poor nutritional requirements because it has the well-developed radicular system that allows it to extract all the nutrients it needs from the soil. In conclusion, sorghum can be a culture that avoids losses in years with very high temperatures. From an ecological point of view, 1 ha of sorghum absorbs carbon dioxide annually from the atmosphere up to 50-55 t / ha, while the hardwoods absorb 16 t / ha / y of dioxide and the rest of the grains 3-10 t /ha /year.

At the same time, sorghum is very valuable from a nutritional point of view. Increases the nutritional value of bread, salads and soups, when added to them. In Asia, it is highly appreciated and used in food preparation, and in the West is highly sought after by people with gluten

intolerance. It is appreciated by nutritionists because it provides almost double the number of proteins compared to rice. Also, with a nutritive value close to maize, sorghum grains have a wide use in feeding cattle to fat and poultry. The sorghum fan is superior to corn as it contains large amounts of calcium salts, phosphorus and carotene.

Sorghum is a magical solution for western Romania, Serbia and Hungary, where the attack of the pest *Diabrotica* sp. is great, the species being resistant to this pest. Another great advantage of sorghum culture is the low need for inputs, especially for fertilizers. The sorghum needs small amounts of phosphorus and potassium, requiring: 20-60 kg / ha b.i. The nitrogen requirement is somewhat higher but lesser than maize, ie 50-80 kg bw / ha.

ACKNOWLEDGEMENT

This work was supported by a grant of the Romanian Ministry of Research and Innovation, CCCDI-UEFISCDI, project number PN-III-P1-1.2-PCCDI-2017-0566 / *Complex system of integral valuability of agricultural species with*

energy and food potential (contr. 9PCCDI / 2018), within PNCDI III, component Project 2 - Optimization of the cultivation technologies of some species with energy and food potential (sorghum, hemp and hemp).

BIBLIOGRAPHY

1. **Cerempei V.**, 2016 - *Tehnologia și mijloacele tehnice de producere și utilizare a biocombustibililor în baza alcoolilor monoatomici*, Book, Chisinau, Republica Moldova.
2. **Duca Gh.**, 2010, *Propunerile Academiei de Științe a Moldovei privind eficientizarea sectorului energetic*. Ed. Akademos, nr. 1(16), pp. 34-42, ISSN 1857-0461.
3. **Goian M.**, 1991 - *Sorghul zaharat*, USAMVB Timișoara, pp.78- 178.
4. **Hăbășescu I., Cerempei V., Deleu V.**, 2009, *Energia din Biomasă: tehnologii și mijloace tehnice*. Chișinău, Ed. Bons Offices, ISBN 978-9975-80-301-4.
5. http://www.cnaa.md/files/theses/2016/50722/valerian_cerempei_thesis.pdf.
6. <http://www.db.agepi.md/inventions/PdfHandler.ashx?id=a%202006%200255&linkP>.
7. <https://www.stiriagricole.ro/tehnologia-de-cultivare-a-sorgului-una-dintre-cele-mai-bune-alternative-la-cultura-porumbului-in-zonele-secetoase-32420.html>.
8. <http://agrointel.ro/43813/siropul-de-sorg-un-produs-banal-cu-care-fermierii-pot-da-lovitura-pe-piata-ma>.
9. <http://agrointel.ro/5462/tufa-din-care-se-fac-maturile-mai-foloseste-la-biogaz-sau-ca-furaj-si-aduce-profit-pe-timp-de-seceta/>.
10. <https://www.stiriagricole.ro/tehnologia-de-cultivare-a-sorgului-una-dintre-cele-mai-bune-alternative-la-cultura-porumbului-in-zonele-secetoase-32420.html>.