

EXPERIMENTALLY RESEARCHES ON CERTAIN TYPES OF SPRAYING DEVICES USED IN FRUIT PLANTATIONS

GLODEANU MIHNEA, ALEXANDRU TUDOR, BORUZ SORIN

University of Craiova

Keywords: drift, sprinkling machines, liquid rate, spraying devices

ABSTRACT

Reduce the loss of fluid and decrease environmental impact due to the phenomenon of drift, at the same time with a high biological efficiency of pulverization was one of the major problems of the technology of spraying treatments. For this reason they were designed and constructed spraying devices able to significantly reduce the loss of liquid.

INTRODUCTION

Uneven distribution of solution sprayed into the vegetable mass and uncontrolled dispersion of droplets in the environment, both in the form of drift or because of sedimentary from the ground represent one of the major problem in case of treatments to combat diseases and pests in crops with high waist (especially fruit plantations) with conventional spraying ramps (Bădescu M., and colab., 2003; Glodeanu M., and colab., 2002).

The removal of these deficiencies was only possible through the use of advanced spray systems, which have a considerable advantage of reduction of the soil contamination with pesticides (Kifferle G. And W. Stahli, 2001).

MATERIALS AND METHODS

The main objective of experimental determinations was the realization of a comparative study concerning the quality index obtained in the case of certain works to combat diseases and pests in a fruit plantation, using two types of spraying booms (Nagiu Livia, 2008):

- semicircular ramp (usually) which equipped a sprinkling machine with axial fan;
- ramp tunnel spraying equipped with tangential fans (with three sections for each half row)

Experimental investigation was based on the collection of particles distributed on a well-defined area, followed by quantitative analysis of samples by weighing, the acquisition and processing of data in the computerized system.

Experimentation of spraying devices in the fruit plantation was done after a method that consisted in determining the following qualitative indices of the work:

- the average quantity of distributed solution on samples;
- uniformity of distribution on the direction of travel of the machine (Stahli W. And T. Bungescu, 2005).

1. *The average quantity of distributed solution on samples test (g_m), shall be determined with relation:*

$$g_m = \frac{\sum_{i=1}^n g_i + g_{0i}}{n} - g_{0m}; \quad g_{0m} = \frac{\sum_{i=1}^n g_{0i}}{n} [g] \quad (1)$$

where:

- g_i is the quantity of solution distributed on a samples test, in g;
- g_{0i} – weight of samples test in initial condition, in g;
- g_{0m} - initial weight of samples test, in g;
- n – number of sample test.

2. *Uniformity of distribution on the direction of travel of the machine (U_{dl}) shall be determined with relation:*

$$U_{dl} = 100 - C_v = 100 - \frac{\sqrt{\sum_{i=1}^n (g_i - g_m)^2}}{g_m} \cdot 100[\%] \quad (2)$$

where C_v is the coefficient of variation of the distribution uniformity on the direction of travel, in %.

Experiments were performed in an intensive orchard with the distance between the rows of 2.8 m. For the execution of the tests we used samples of tissue paper (with an active area of 0,16 m²).

Test samples have been placed on the trees crown at three different heights: 0,4 m; 1,3 m, respectively 2,2 m above the ground.

The length of the journey on which were placed the samples test was 10 m.

Layout mode of samples of the samples test is shown in figure 1 and 2. Before replacing the paper samples proceed to their individual weighing (g_{0i}) and registering the determined values in computer.

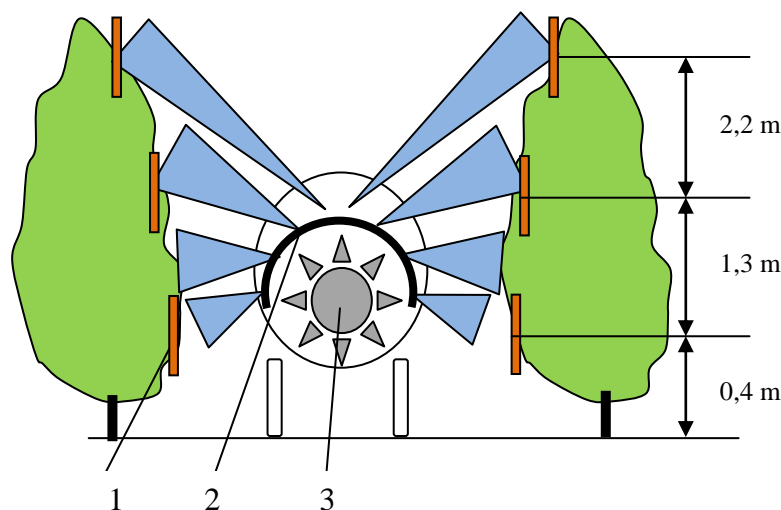

Fig.1. Mode of work for the experimentation of a semicircular spraying boom: 1-sample specimens; 2-semicircular spraying boom; 3-axial fan.

To determine the distribution charts on the direction of travel of the machine and the work quality index there have been achieved a number of two tests, under conditions of constant displacement speeds, specific working process.

Liquid prescribed norm was 1,200 l/ha.

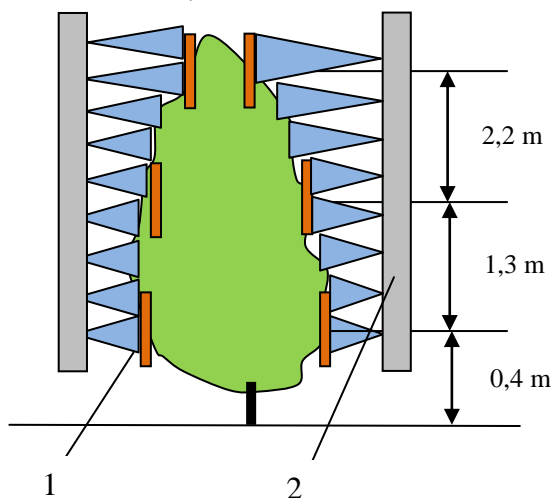

Fig. 2. Mode of work for the experimentation of a tunnel spraying boom: 1-sample specimens; 2-tunnel boom.

To determine the distribution charts on the direction of travel of the machine and the work quality index there have been achieved a number of two tests, under conditions of constant displacement speeds, specific working process. Liquid prescribed norm was 1200 l/ha.

RESULTS AND DISCUSSIONS

The data file with the values of the average quantities of distributed solution, respectively of the average liquid norm ensured in the conditions of the first test are presented in table 1.

Graphical representation of data file with the values obtained from the testing I, allowed obtaining longitudinal distribution charts done by the machine in these conditions (figure 3,4,5) (the dependence between the quantity of solution administered per unit of treated surface expressed in g, and distance traveled, in m).

Table 1

Average quantities of distributed solution and average standards provided under the conditions of test I

Height of the location of the samples test (m)	Average distributed quantity g_m (g)	Average standard ensured N_m (l, kg/ha)	Average distributed quantity g_m (g)	Average standard ensured N_m (l, kg/ha)
	Half left row		Half right row	
0,4 m	17,04	1065,3	17,00	1062,5
1,3 m	16,57	1035,6	16,52	1032,5
2,2 m	15,96	997,5	15,84	990,0

Results from the testing I allow the calculation of the deviations from the average prescribed quantity on unit surface and also the longitudinal distribution uniformity (U_d) values, which carried out the machine in this case (table 2).

Table 2

Deviations from the average prescribed quantity on unit surface and longitudinal distribution uniformity values, in conditions of test I

Height of the location of the samples test (m)	Deviation from the average prescribed quantity (%)		Longitudinal distribution uniformity (%)	
	Half left row	Half right row	Half left row	Half right row
0,4	11,2	11,4	80,6	80,1
1,3	13,6	13,9	73,9	72,6
2,2	16,8	17,5	68,3	67,5

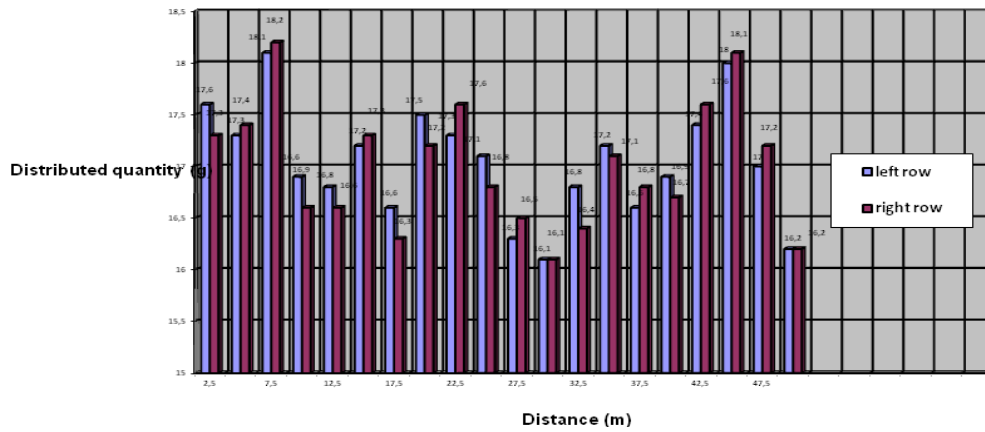

Fig. 3. Longitudinal distribution diagram achieve by the machine in conditions of test I, for the height of the samples test of 0,4 m.

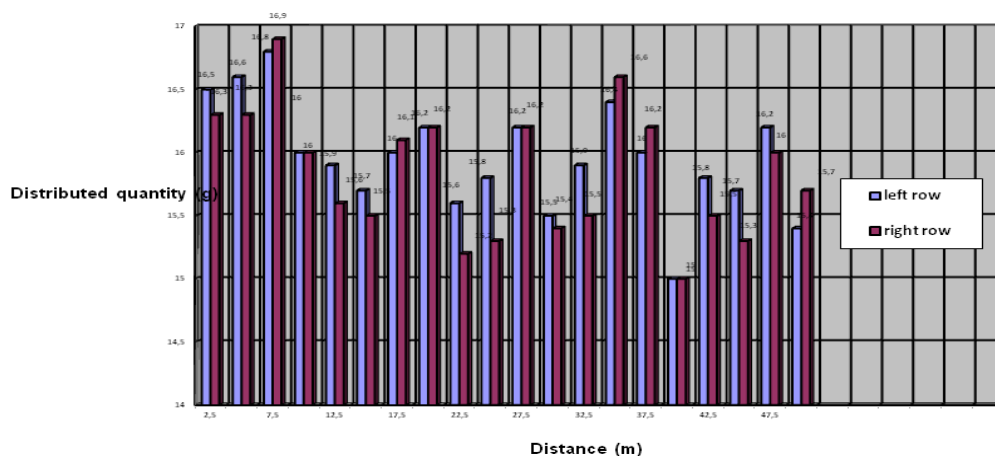

Fig. 4. Longitudinal distribution diagram achieve by the machine in conditions of test I, for the height of the samples test of 1,3 m.

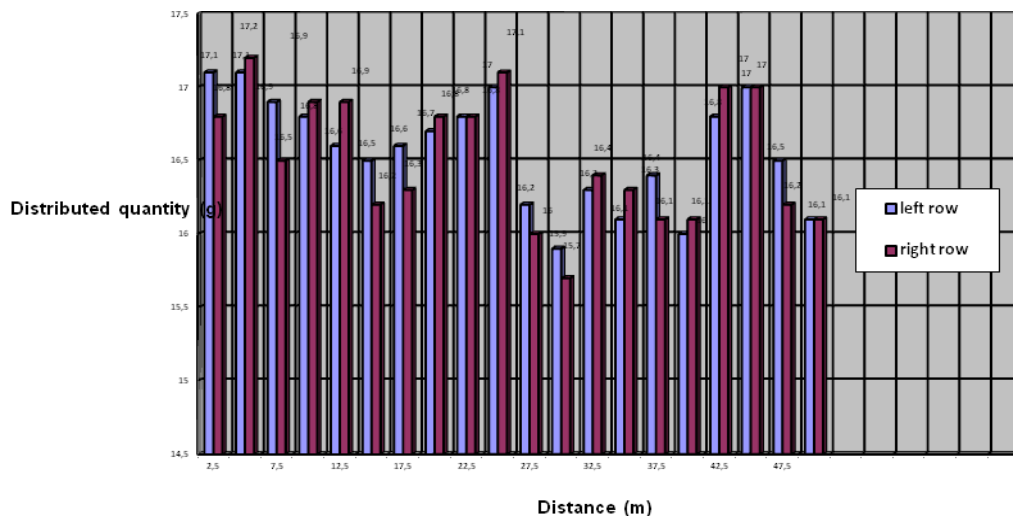

Fig. 5. Longitudinal distribution diagram achieve by the machine in conditions of test I, for the height of the samples test of 2,2 m.

Similarly, the graphical representation of the data file with the values obtained at test II (table 3) allow to obtain the longitudinal distribution charts achieve by sprinkling machine in these conditions (figure 6,7,8).

Table 3

Average quantities of distributed solution and average standards provided under the conditions of test II

Height of the location of the samples test (m)	Average distributed quantity g_m (g)	Average standard ensured N_m (l, kg/ha)	Average distributed quantity g_m (g)	Average standard ensured N_m (l, kg/ha)
	Half left row		Half right row	
0,4 m	19,60	1225,3	19,54	1221,5
1,3 m	18,45	1153,4	18,39	1149,6
2,2 m	18,28	1142,8	18,17	1135,6

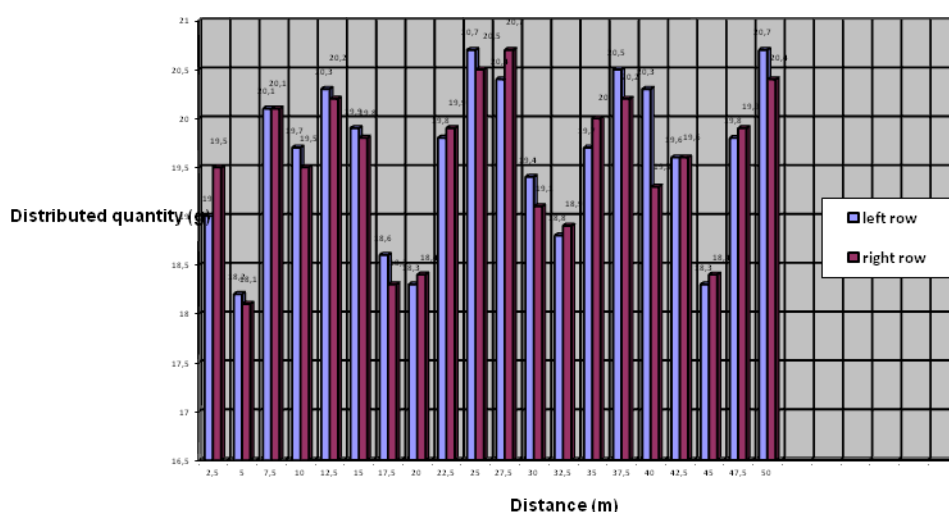

Fig. 6. Longitudinal distribution diagram achieve by the machine in conditions of test II, for the height of the samples test of 0,4 m.

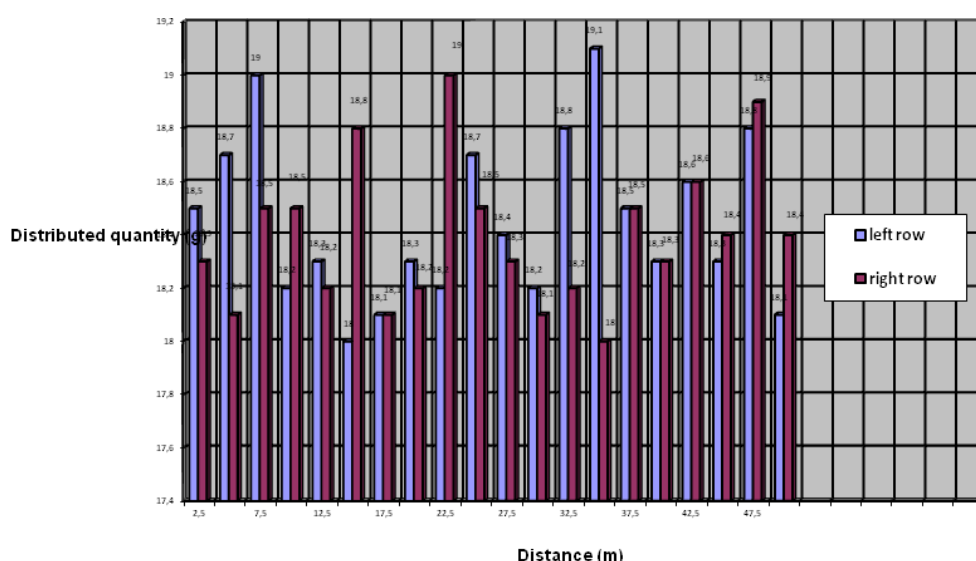

Fig. 7. Longitudinal distribution diagram achieve by the machine in conditions of test II, for the height of the samples test of 1,3 m.

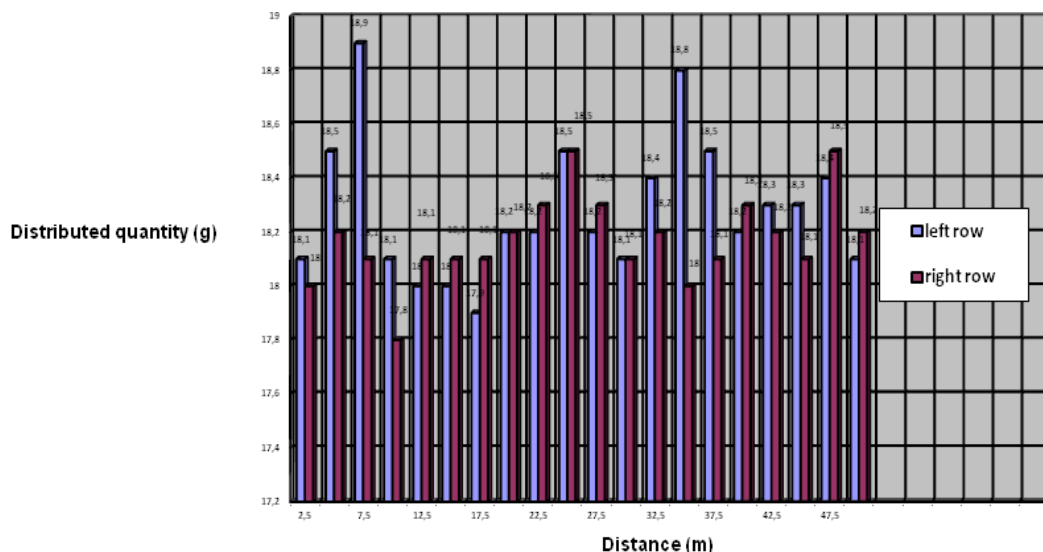

Fig. 8. Longitudinal distribution diagram achieved by the machine in conditions of test II, for the height of the samples test of 2,2 m.

The values of the deviations from the average prescribed quantity on unit surface and also the longitudinal distribution uniformity (U_{dl}) values, are presented in table 4.

Table 4

Deviations from the average prescribed quantity on unit surface and longitudinal distribution uniformity values, in conditions of test II

Height of the location of the samples test (m)	Deviation from the average prescribed quantity (%)		Longitudinal distribution uniformity (%)	
	Half left row	Half right row	Half left row	Half right row
0,4	2,10	1,79	94,6	93,8
1,3	3,90	4,20	90,6	91,1
2,2	4,80	5,30	89,4	88,9

CONCLUSIONS

Analysis of the results obtained at test I (semicircular spraying boom) highlights the following:

- stability of liquid prescribed norm is not provided for any height of samples test (both on the half of the left row and also on the half of the right row), the deviations from the average prescribed quantity on unit surface being between 11.2% and 17.5%;
- the longitudinal distribution uniformity (U_{dl}) ensured by the sprinkling machine has values between 67,5% and 80,6 %; the values fall within basic technical requirements only for the layout of the samples test of 0,4 m.

Analysis of the results obtained at test II (tunnel spraying boom) highlights the following:

- stability of liquid prescribed norm is provided for all heights of samples test, the of deviations from the prescribed average being very low (values between 2,1% and 5,3%);
- the longitudinal distribution uniformity (U_{dl}) ensured by the sprinkling machine has increased values (between 88,9% and 94,6) which fall within basic technical requirements; the obvious advantages offered by this type of ramp is advocating in favor of widespread use in fruit plantations.

BIBLIOGRAPHY

1. **Bădescu M., M. Glodeanu, T. Alexandru, Sărăcin, I.**, 2003, *Farm machinery*, UNIVERSITARIA Publishing House, Craiova.
2. **Glodeanu M. and colab.**, 2002, Code of good practice concerning the use of agricultural equipment, AIUS Publishing House, Craiova.
3. **Kifferle G., W. Stahli**, 2001, *Spritz-und Sprühverfahren in Pflanzenschutz und Flissig, dungung bei Flächenkulturen*, Books on Demand-Norderstedt.
4. **Nagiu Livia**, 2008, *Machinery and horticultural equipments*, RISOPRINT Publishing House, Cluj-Napoca.
5. **Stahli W., T. Bungescu**, 2005, *Spraying machines and apparatus in vitipomicole and forestry plantations*, MIRTON Publishing House, Timișoara.