

CONSIDERATIONS REGARDING THE PROCESS OF COMPACTION AND SOIL LOOSENING

CROITORU ȘT.¹⁾, BĂDESCU M.¹⁾, BORUZ S.¹⁾, IVANCU B.²⁾, MARIN E.²⁾, VLĂDUȚ V.²⁾, MANEA D.²⁾, CUJBESCU D.²⁾, CABA I.³⁾

¹⁾University of Craiova; ²⁾INMA Bucharest; ³⁾MUNAX SRL Timișoara / Romania

Keywords: soil loosening, compaction, soil, properties

ABSTRACT

The soil works are a series of agrotechnical operations that modify the physical condition of the soil using mechanical means. The purpose of the soil work is to create optimal conditions for the crop in order to obtain harvests as large as possible, through soil works being able influencing both the content of air, water and soil temperature and nutrient content adjustment. This paper presents some considerations concerning the characteristics and the properties of soil, respectively the measures to be taken to reduce compactness.

INTRODUCTION

Soil compaction is the process of reducing the volume of soil under the influence of environmental conditions (natural compaction) and of some influencing factors (artificial compaction). Artificial compaction (anthropogenic) is due to the traffic carried out on field by the units that carry out various works imposed by technologies of mechanization and some transport works of technological or agricultural products.

Deep soil loosening is a work performed by mechanical means for modifying characteristics of the soil performed in the compacted and impermeable layer, thus increasing the water storage capacity, creating the conditions for normal ventilation and heating of soil and activation of the biological soil processes.

Considerations regarding soil condition in our country that require deep loosening works

Table 1

Distribution of areas of land that requires deep loosening works

Crt. No.	The name of the County	The agricultural area [ha]	Distribution after the urgency of soil loosening			Total area concerned	
			high [ha]	middle [ha]	reduced [ha]	ha	% of agricultural
The top 10 counties with the largest surface compacted (26-45%)							
1	Olt	439.321	85.000	60.000	52.000	200.000	45,52
2	Argeș	348.324	78.000	66.000	10.000	154.000	44,21
3	Satu Mare	323.760	75.000	48.000	13.000	136.000	42,01
4	Teleorman	505.561	85.000	40.000	81.000	206.000	40,74
5	Sibiu	319.500	36.000	22.000	58.000	116.000	36,31
6	Bihor	479.192	90.000	50.000	20.000	160.000	33,39
7	Suceava	354.338	29.000	32.000	55.000	116.000	32,74
8	Brașov	303.900	30.000	26.000	38.000	94.000	30,93
9	Arad	500.257	62.000	55.000	20.000	137.000	27,38
10	Mureș	411.340	22.000	18.000	68.000	108.000	26,26
The top 10 counties with the lowest surface compacted (0-12%)							
1	Constanța	583.701	0	0	0	0	0
2	Tulcea	335.854	0	0	0	0	0
3	Ialomița	525.873	5.000	0.000	5.000	10.000	1,90

Crt. No.	The name of the County	The agricultural area [ha]	Distribution after the urgency of soil loosening			Total area concerned	
			high [ha]	middle [ha]	reduced [ha]	ha	% of agricultural
The top 10 counties with the largest surface compacted (26-45%)							
4	Vaslui	410.903	6.000	4.000	0.000	10.000	2,43
5	Galați	359.210	7.000	4.000	0.000	11.000	3,06
6	Brăila	398.805	15.000	5.000	5.000	25.000	6,27
7	Iași	408.278	10.000	12.000	10.000	32.000	7,84
8	Harghita	402.048	10.000	10.000	17.000	37.000	9,20
9	Buzău	404.109	24.000	10.000	14.000	48.000	11,88
10	Sălaj	243.918	10.000	3.000	17.000	30.000	12,30
	TOTAL	15.067.362	1.269.000	741.000	960.000	2.970.000	19,80

The data in table 1 show that only two of the country's counties (Constanța and Tulcea) don't currently have agricultural lands which require being deep loose. On first places are counties Argeș, Olt, Teleorman and Satu Mare in wich the land that requires deep loosening works represents over 40% of all agricultural areas of the respective counties. Large areas of land that requires same work are the counties of Timiș, Arad, and Ilfov.

Studies conducted by experts show that outside of these areas that, at present, due to their natural properties, demands deep loosening work, in the future this work will become necessary at any other cultivated land, as a result of rising soils compactness in terms of modern agriculture, which will become more intensive, more mechanized and irrigated.

The way, in which they are observed from satellite, the soil types on Romanian territory (Figure 2) can be viewed on the map in Figure 1.

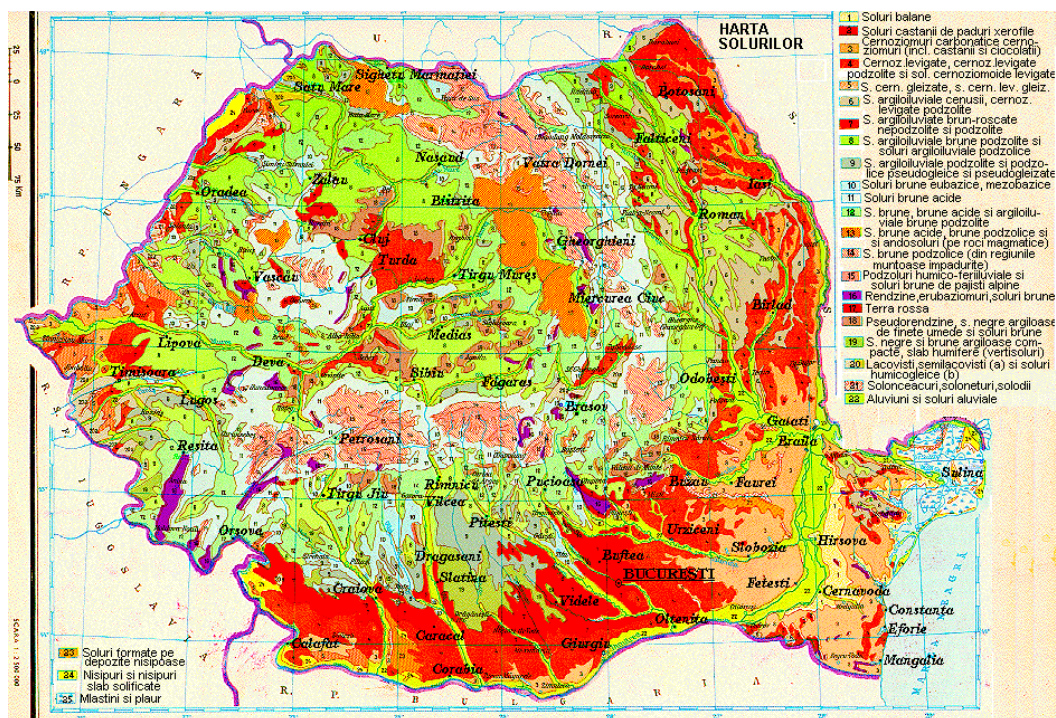

Figure 1 - Soil Map of Romania [9]

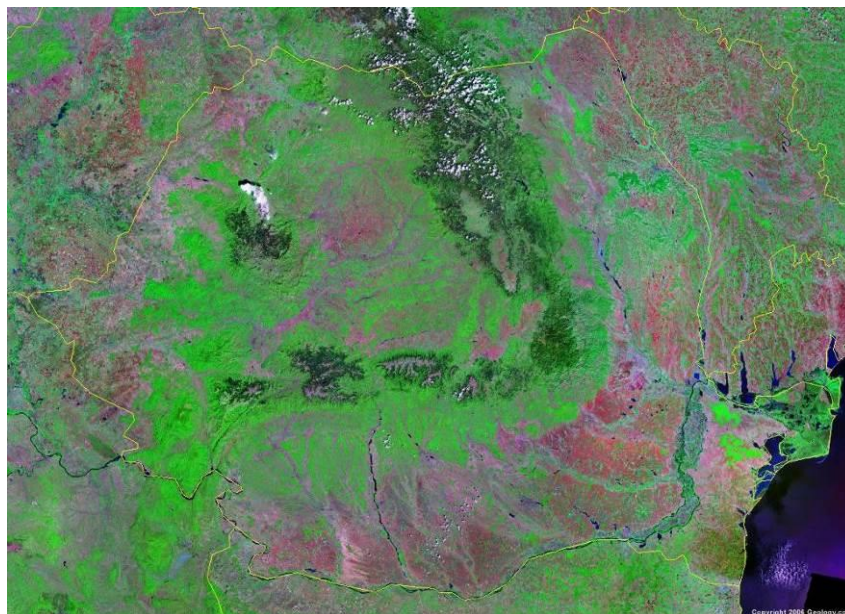

Figure 2 - Soil Map of Romania, seen from satellite [10]

MATERIAL AND METHOD

Identification of soil types in Romania that require deep soil loosening works

Soils that need to be loose are generally colder; the snow melts harder, being characterized by washing of the calcium, sometimes with total extinction of C layer of calcium accumulation. Also on podzolic soils are found a decrease of humus by washing, which reduces soil fertility.

The processes of washing humus, clays and calcium at the top of the profile lead to damage the glomerular soil structure, to separation of silica that gives a whitish-gray color to A₂ soil layer and to the accumulation of clays in B layer starting at 40 ... 50 cm, creating one or more layers, compact, compacted and impermeable.

Destruction of soil structure and compaction of arable layer in depth, through clay accumulation, reduces the water storage capacity, prevent soil aeration, damage aerohidric balance and replace the aerobic microbiological processes with anaerobic processes that are harmful to plant life.

This is because soil compaction, lack of air and the release of anaerobic processes are leading to asphyxiation of plants. The soil compaction, in depth, due to pedogenesis causes, shown above, plus mechanical compaction of the soil in the upper layers due to repeated passage of working units which on land with excessive humidity have an maximum adverse effect.

- **Vertisol soil type**

Vertisol soils type are clay soils, heavy and black throughout the depth profile. They meet on the lower foothills, high fields, old terraces and on smooth surfaces without external drainage.

In profile, to these soil the A layer is 20 ... 50 cm thick and has a slight tint dark gray color. Follows a transition A / B of 20 ... 30 cm, the same color as the layer A. Layer B exceeds 100 cm and is usually dark, dark brown, often with yellow or rust spots.

Clay accumulation begins at a depth of 50 cm, where the percentage of clay is over 50% and reaches its maximum value at 80 cm.

Physical and physical-mechanical properties are unfavorable: vertisols are compact soils, hardly permeable, in wet periods presented excess water (Figure 3), and in periods of drought form deep cracks of 80...100 cm with openings of 5 ...15 cm (Figure 4).



Figure 3 - The appearance of a compact soil in wet periods



Figure 4 - The appearance of a compact soil in drought periods

- **Clayey podzolic soils**

These soils are found in the same area of soils shown before, occupying large areas, being found on horizontal relief units, practically free from external drainage, on older units consist of deposits rich in sand and having an acid character. They are in the most humid portions of joint area. The process of formation of these soils is oriented in the podzolic direction.

A₀ layer of 2 ... 4 cm thickness, consists of decomposing organic debris. A₁ layer of 10...20 cm thickness, has a light gray color. A₂ layer of 10...30 cm thickness, is lighter than the A₁ layer.

The B layer, with thickness varying from 40 to 120 cm, is yellowish-brown color, the C layer is missing and the calcium carbonate is being completely washed away. At level of B layer is a huge plus of clay, the textural differentiation index exceeding sometimes the value 3. The maximum accumulation of clay begins at depth of 50...60 cm.

- **Brown soils (low podzolit)**

Brown soils (low podzolit) are originally brown soils which have suffered a slightly podzolite. Due to an acidic soil reaction, the migration of colloids has intensified. The A layer highlights the presence of silica particles and there is a deterioration of soil structure. The B layer has accumulated clay; the textural index may exceed 1, 4, with frequent separations of iron and manganese. The layer rich in clay, hardly permeable to water, is found at depths of over 40 cm.

- **Brown podzolit soil**

Podzolic brown soils have A₁ layer with a thickness of 10 ... 20 cm and are usually have a grey-brown colour. After, follows a podzolic layer of 10 ... 20 cm thickness, lighter in color.

Layer B, well defined, has a thickness of 60 ÷ 160 cm, with a color brown to yellowish brown with reddish spots. The B layer, starting at 50 cm, has a considerable addition of clay; the textural differentiation index is sometimes at the value of 2. Due to the presence of clay, of compaction and sealing of layer B, the aerohidric regime of these soils is faulty.

RESULTS AND DISCUSSIONS

Deep soil loosening aims to increase lacunar space of soil layers lying beneath arable layer, without mixing, overturning or reversing soil layers. This is a specific work of hard and compacted soil, alternatively affected by the excess and shortage of humidity, as well as other types of soils which posing limitations on production capacity caused by salinization, alkalization, pollution, etc. Excess moisture frequently occurs in wetter and low through evapotranspiration periods, on soils that have a clay layer, compact and waterproof under arable layer. Because of the low permeability of this layer, rainwater can not seep towards and accumulate in the upper portion or surface.

Deep soil loosening, without turning the furrow is made for puncturing the impermeable layer of soil and cause water infiltration in the upper layers. In dry areas, water accumulated in depth of the soil set aside for periods without precipitation, and in wet areas this water must be removed by drainage systems.

At the same time, by deep soil loosening are obtained positive effects on improving the conditions of aeration, water permeability, storage capacity of rainfall, as well as favoring the development of a deeper root system (Figure 5) and an intensification of biological activity in the soil.



Figure 5 - The development of the root system of the plants on the ground with deep soil loosening (left) and without deep soil loosening (right)

The main rules to be considered in the execution of this work in optimal conditions with minimal energy consumption are:

- *Soil loosening depth* is determined by clay content and its distribution in the profile. The minimum depth can not be less than 40 ... 45 cm, and the maximum depth does not exceed 80 ... 90 cm. On soils affected by excess moisture, especially when there is a

landscaped drainage system, soil loosening depth uniformity is very important in the sense of favoring drain excess water to drain network.

- *Working width* depends on the soil loosening depth and on the type of machine. A good soil loosening intensity is obtained when the width is equal to the two soil loosening depths h : $l = 2 h$. The distance between two active pieces is about $0,5 \dots 0,7 l$, which can ensure an appropriate soil loosening depth h . Distances can be considered only on landscaped lands with drainage works.

- *The moment executing the work.* Deep loosening may have a more prolonged effect only when are performed under optimal conditions of humidity. Optimal humidity conditions are met when humidity is between 60 ... 90% of the active humidity range. At humidity lower than 60% the soil being too dry, result large lumps of soil that are processed hard and with high energy consumption. In the process of soil loosening the soil must break forming irregular fissures and cracks, structural elements must be misplaced from each other, pushed to the side and towards the surface so that it can no longer be able to recover the original placement. To humidity higher than 90%, the soil loosening reduced to a simple cut of the soil by the working organ.

- *Execution time.* The work is performed in summer, during july-august or autumn after harvesting crops, before the plowing. Deep loosening may continue in october, if not intervening the wet periods, especially if the land is not intended for other autumn crops.

Also, deep soil loosening must be preceded by application of organic fertilizers and, where appropriate, by application of phosphate fertilizers and amendments to remove excess water.

Choosing land that requires deep soil loosening work is based on a number of criteria such as pedological, climatic, geomorphological, lithological, hydrogeological etc. If one of these criteria is not satisfied, it becomes restrictive to perform deep soil loosening on the respective surface.

From the pedological point of view, have priority the soils which are affected by excess humidity of pluvial nature and those with a degree of compaction above 10% and low air and water permeability. For example, the first category includes compact clay soils, the podzolic, brown-reddish etc., and from the second groups those with clay-containing more than 30%.

- In terms of climate, deep soil loosening is necessary and possible in areas with normal hidric balance surplus for the period from october to march and normally substantively flawed from july to september.
- In terms of geomorphology, the land must have a slope less than 15% to allow the activity of soil loosening of technical equipments.
- In terms of lithology, the land must have a substrate and a slope that does not favor landslides.
- In terms of hydrogeology, it is necessary that the soil is not affected by the groundwater influences on soil loosening depth in periods of excess humidity.
- From the point of view of combating excess humidity, the scheme of a soil profile before and after the deep soil loosening can be presented in two situations, namely:

- *Case 1:* When the low permeability clay layer is relatively thin and its base is at a depth from the ground surface up to 0.6 ... 0.8 m, so it can be fully mobilized with deep soil loosening equipments (Figure 6).

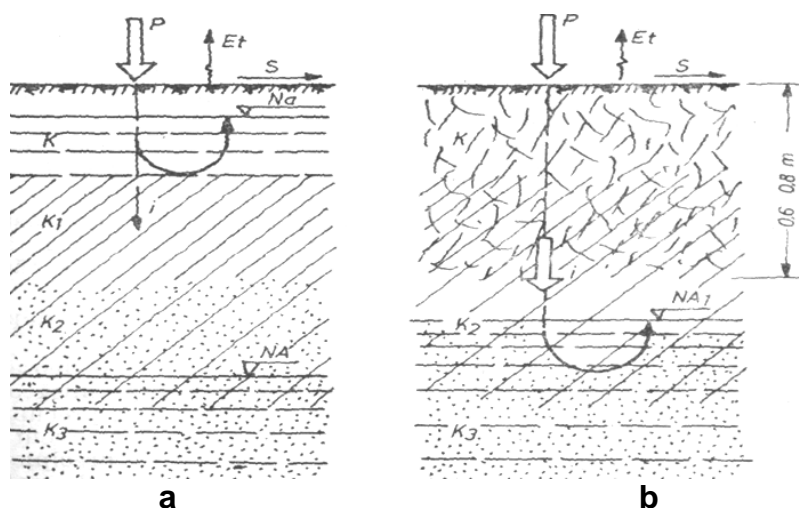

Figure 6 – The effect of deep soil loosening on land with hard permeabil clay layer located at small depth
a – before soil loosening; **b** – after soil loosening

- Case 2: When low permeability clay layer thickness is greater than 0.6 to 0.8 m and can not be fully penetrated with existing deep soil loosening equipments, because it exceeds thereof maximum working depth (Figure 7).

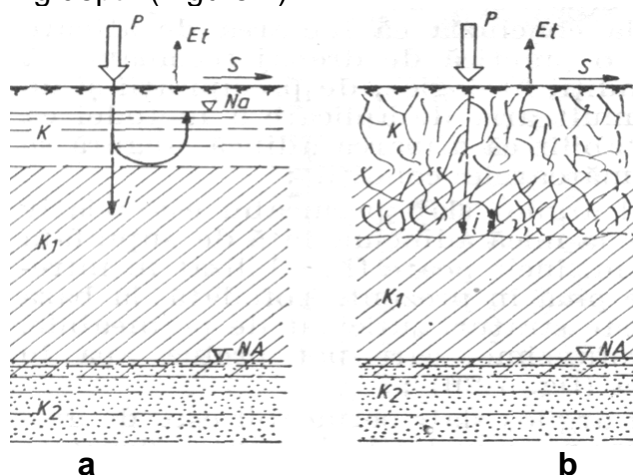

Figure 7 – The effect of deep soil loosening on land with hard permeabil clay layer located at small depth
a – before soil loosening; **b** – after soil loosening

On these lands, in addition to the agroameliorative and pedoameliorative works, aimed to restore soil structure, increase its permeability, increase the capacity of water storage and aeration porosity, on a depth as high as the profile, are often needed and drainage systems, through buried or surface channels. Sometimes, in situations where to active organs of deep soil loosening can be attached punches draining, to carry out simultaneously the underground network of water draining channels, to the collection and disposal systems, as seen in figures 8 and 9.

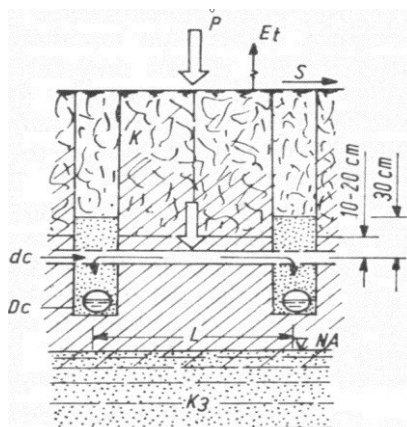

Figure 8 - The effect of deep soil loosening on land with hard permeabil clay layer of large thickness
(after soil loosening and drainage)

The meanings of the notations in Figures 6, 7 and 8 are as follows:

- P - the amount of rainfall;
- E_t - evapotranspiration;
- s - drained water from the surface of the land;
- i - infiltrated water into the depth;
- Na - seasonal groundwater level, accumulated over the low permeability layer, which can reach even the land surface;
- NA - permanent groundwater level located in permeable layers consisting of sandy and gravel formations;
- dc - mole drain;
- Dc - drain tube collector.

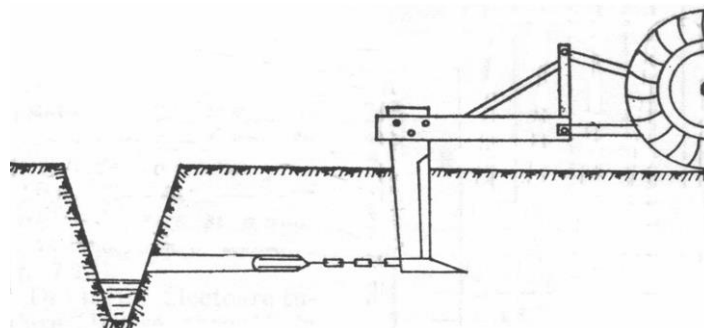

Figure 9 - Execution of mole drainage simultaneously with deep soil loosening, on a landscaped land with drainage channel

When the volume of rainfall exceeds the water consumption through evapotranspiration, the possibilities of drainage on the surface of the land and of infiltration into deeper arable layers, is formed on the soil profile, above the clayey podzolic layer poorly permeable, an accumulation of water that saturates plant roots area, staying on the surface.

Because soil loosening, the impermeable soil layer is destroyed and the water is no longer staying on the surface of the land and it may drain in depth, and the soil is aerating (Figure 10, b and c). Therefore on the sloping land, through soil depth loosening, is achieved the possibility to avoid water infiltration into the soil and soil erosion, due to water flow downhill (Figure 10, d and e).

Following the work of deep soil loosening, the plants can develop roots in the best conditions (Figure 10, f).

At soil loosening organs that have vibratory movements, the running resistance force through soil is reduced up to 40%, compared to the rigid force, and at organs with elastic support is up to 20%, which makes that, for great depths, to prefer these kinds of working organs.

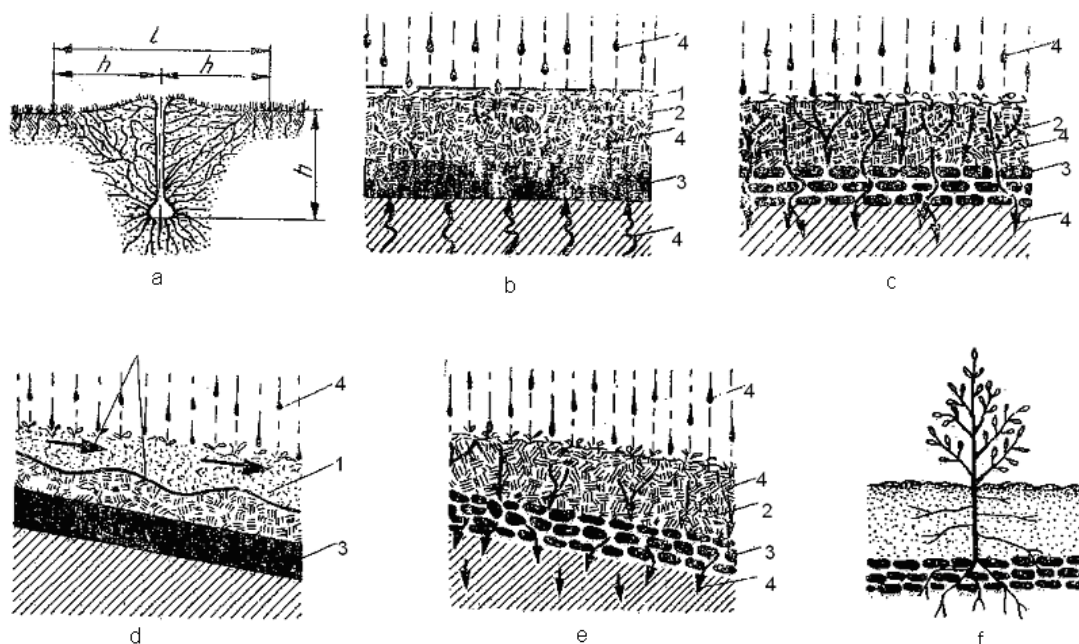

Figure 10 - The working process of the machines for deep soil loosening:

a- loose soil section: h- working depth; l- working width (2h); b- not worked soil section on flat land; c- worked soil section on flat land; 1- standing water; 2- arable soil layer; 3- impermeable soil layer; 4- water and its circuit; d- not worked soil section on sloping land; e- worked soil section on sloping land: 1- water and soil from the surface; 2- arable soil layer; 3- impermeable soil layer; 4- water and its circuit; f- favorable conditions for plant development.

Changing the negative characteristics of these soils can be made through a complex of measures and structures contained within the generic agropedoameliorative measures, such as leveling, shaping, drainage, deep soil loosening, subsoiling, irrigation, fertilization, crop system etc.

Of these, through deep soil loosening or subsoiling, aims to achieve a radical change in the characteristics of the soil in compact layer, compacted and impermeable, thus increasing the water storage capacity, creating the conditions for normal aeration and heating of the soil and the activation of biological processes in the soil [14, 15, 16 and 17].

Through the work of deep soil loosening increases the pore volume from the soil, increases lacunar space that allows rapid water drainage and surface water flow is accelerating. Beneath arable layer, by reducing compactness and cohesion, it creates favorable conditions for the penetration of plant roots, increasing their feeding area and increasing their ability for resistance to drought.

So, a proper definition of the work of **deep soil loosening** would be that of agropedoameliorative operation, carried out with mechanical means, through which alter the physical state of the soil, including under arable layer, for the purpose of reducing the degree of natural or gained compaction.

When deep soil loosening works are performed at a level of quality corresponding to the agropedology requirements, at a cost price as low as possible and with low power consumption, it requires ensuring the equipment with superior structural and functional parameters.

Requirements for execution of deep soil loosening works are based on pedologic criteria, alternative presence of periods of excess rainfall and pluvial humidity deficiency in soil during plant vegetation and the presence of total porosity deficient.

Topographic and lithologic, deep soil loosening is generally desirable on sloping land or on lands without alternating layers favoring landslides.

Hydrological, deep soil loosening is necessary in territories subjects to alternations of excess and deficit humidity, with or without water or groundwater contributions, drainage, floods etc.

Agrophytotechnical, deep soil loosening is required in the practice of intensive agriculture and ensuring economic harvest gains.

Based on studies conducted, experts from the profile institute (ICPA Bucharest) developed the agronomic and pedological requirements for deep soil loosening works [3, 4, 6, and 7].

According to them, for works deep soil loosening are interested primarily the podzolic, reddish brown, vertisols, marshy grounds and heavy alluvial soils. Subsoiling work can be carried out on the chernozem, medium brown soils and alluvial soils.

No deep soil loosening works are performed on sandy soils, soils with gravel and superficially hard rock, on wetlands and lands with groundwater at a depth of less than 1 m, land with slopes over 15% and on lands with landslides or springs coast.

It is recommended that optimal humidity for deep soil loosening works to be 80 ÷ 90% of water capacity in field soil.

This amount represents about 60 ÷ 90% of active humidity range (I.U.A.), which is the interval between the wilting coefficient and water capacity in field soil.

Soil work at low humidities below 60% of I.U.A. is achieved with high fuel consumption due to higher resistance that opposes the soil to the advancement of active organs, and the work is of poor quality, resulting in large boulders.

To high humidity appear the phenomenon of simple cutting and lateral compression of the soil, which increases the soil volumetric weight and thus reduce its total porosity.

So, agropedology requirements prohibit the execution of works on soil with humidity greater than the upper limit set.

Another requirement for the working direction of the equipments in the plot: it must be perpendicular to the slope in climatic conditions with hydric balance deficient and parallel or oblique compared to slope in terms of hydric balance surplus and on depressionary land.

CONCLUSIONS

The large number of works that are executed by applying conventional technologies that result in soil compaction, damage to its structure, loss of fertility, etc. and which is carried out with a great energy consumption, as the classification need for agricultural works in the optimal periods, led to the extension of the low working technologies (minimum) within which it belongs the system with deep loosening equipment, which implies that the soil work to be done without turning the furrow and crop residues to be incorporated only partially, being one of the most used equipment.

The complex process of soil loosening equipments which carries out soil loosening through mechanical disintegration and shredding, in contrast to the classical plows which cuts the soil after imposed area, allows that the separation area to coincide with the natural split surface of minimum resistance, which has beneficial effects on soil structure and leads to perform the work with less energy consumption

BIBLIOGRAPHY

1. **Colibaș, I., Stângă, N., Stanciu, I., 1971** - *The effect of measures to prevent excess temporal humidity on lands with low permeability, on production of wheat and maize in the piedmont area of the county Bihor*, Works of the Symposium from Sânnicolaul Mare;

2. **Colibaș, I., Stângă, N., Dumitru, E., Canarache, A.**, 1989 – *Integrated technology of execution of scarifying works (deep loosening) and subsoiling (scratching)*, Vegetal production, Grain and technical plants Journal, no. 5, Bucharest;
3. **Dumitru, E., Vig Dinescu, I., Motelică, D., Vâlceanu, S.**, 1988 - *Determination of the pedoameliorative effects of the machine of soil loosening, MAS-60D, equipped with two active vibrators organs compared to the standard equipment in conditions of main soils from S.A.I., I.C.P.A. Report*;
4. **Dumitru, R., Canarache, A.** 1970 - *Method for determining soil humidity between pF 1 and 2 and its relationship to the volumetric weight and the content of clay in the soil*, The Annals of ISCP, no. 38;
5. **Sandu, Gh. ș.a.**, 1981 - *Control of soil development from land improvement systems*. Ceres Publishing, Bucharest;
6. **Sin, Gh. ș.a.**, 1996 - *Improving soils with excess humidity from south of the country*, Vegetal production, Grain and technical plants Journal, no. 12, Bucharest;
7. **Vâjâială, M.**, 1991 - *Agro biological bases of mechanization and processing of agricultural products*. IANB, Bucharest;
8. **Vineș, Gh.**, 1985 - *Soil works: Requirements and guidelines*. Vegetal production, Grain and technical plants Journal, no. 10, Bucharest;
9. <http://www.recolta.eu/arhiva/harta-diferitelor-tipuri-de-soluri-din-romania-9508.html>;
10. <http://www.recolta.eu/arhiva/download-harta-climei-si-a-solurilor-din-romania-alcatuita-de-dr-g-murgoci-9429.html>.