

## Union College Union | Digital Works

---

Honors Theses

Student Work

---

5-2019

# AR Blockers

Emma Merlino

*Union College - Schenectady, NY*

Charles Nelson

*Union College - Schenectady, NY*

Brendan Laing

*Union College - Schenectady, NY*

Follow this and additional works at: <https://digitalworks.union.edu/theses>

 Part of the [Biomedical Engineering and Bioengineering Commons](#)

---

### Recommended Citation

Merlino, Emma; Nelson, Charles; and Laing, Brendan, "AR Blockers" (2019). *Honors Theses*. 2328.  
<https://digitalworks.union.edu/theses/2328>

This Open Access is brought to you for free and open access by the Student Work at Union | Digital Works. It has been accepted for inclusion in Honors Theses by an authorized administrator of Union | Digital Works. For more information, please contact [digitalworks@union.edu](mailto:digitalworks@union.edu).

# AR Blockers

Emma Merlino, Chuck Nelson, Brendan Laing

March 22, 2019

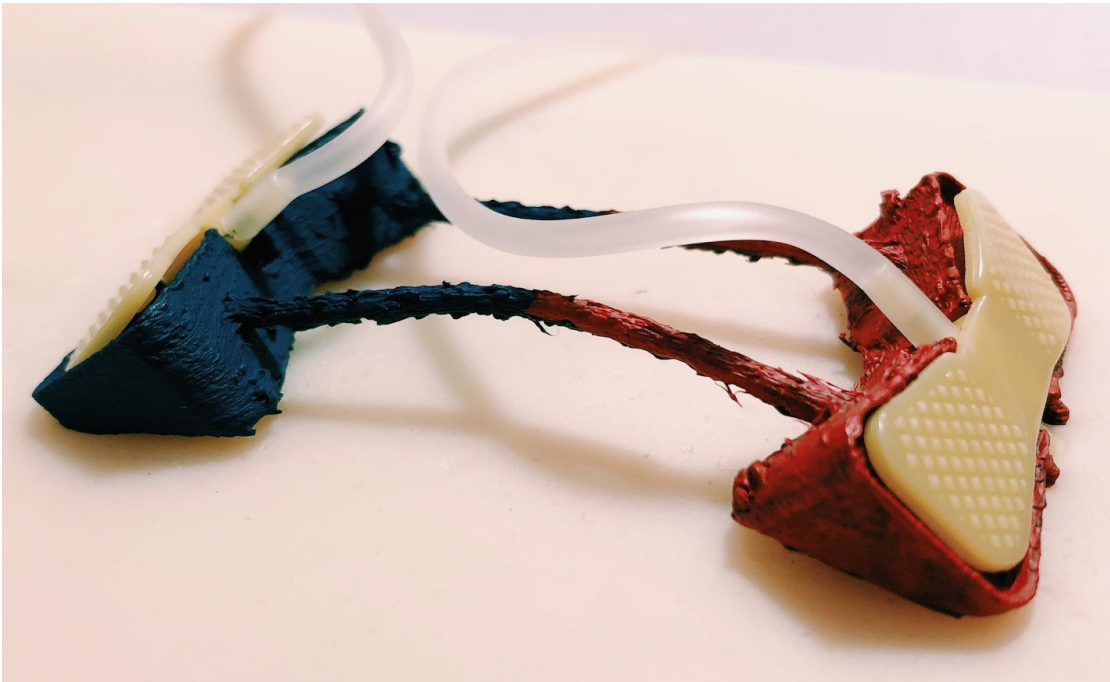

## Table of Contents

I.	Background.....	1
II.	Problem Statement.....	5
III.	Design Objectives.....	6
IV.	Device Functions and Specifications.....	7
V.	Design Requirements.....	9
VI.	Documentation of the Proposed Design.....	11
VII.	Validation of the Design.....	13
VIII.	Anticipated Regulatory Pathway.....	16
IX.	References.....	18
X.	Appendices.....	21

## **Background**

Approximately 660,000 Americans are being treated for kidney failure or end stage renal disease (ESRD) annually [1]. There are also a variety of additional diseases and injuries such as cancer, direct impact burns, sickle cell anemia, and urinary tract infections that cause kidney problems, adding to the number of patients who require dialysis [1]. The greatest need for dialysis is chronic kidney disease, which affects nearly 14% of the human population [2]. Dialysis is necessary, yet it is extremely costly and significantly decreases the quality of life often leading to other diseases such as hypertension, anemia, and vascular calcification [3]. In fact, nearly half of hemodialysis deaths are due to cardiovascular issues that are often a side effect caused by the treatments [3]. Dialysis is also expensive, costing the United States an annual \$49 billion and an American patient an average annual out of pocket cost of \$89,000 [3, 4].

Dialysis is needed when one's kidneys are unable to function fully to remove wastes from the blood due to kidney failure or other complications [5]. A patient can undergo hemodialysis or peritoneal dialysis and the decision is based on patient motivation, desire, geographic location, or physician and patient education [6]. Peritoneal dialysis is not used as often as hemodialysis is in the United States. The process of peritoneal dialysis is through the use of a catheter, a plastic tube that is placed into one's body through surgery. A cleansing fluid is brought into the stomach through the catheter and removed through the same catheter once the filtering processing is complete [7]. The use of peritoneal dialysis has declined over the past 15 years due to a lack of education and exposure by physicians, leading to hemodialysis being the most common choice [8].

Most hemodialysis treatments occur about three times a week, and last between three to five hours each session [5]. Dialysis is completed through a dialysis machine and a filter called a dialyzer. The dialyzer acts as an artificial kidney that is responsible for cleaning and filtering the blood. To connect a patient to a dialysis machine, access points are made into the vein through two needles, the arterial and the venous needle [9]. Blood is removed from the arterial line, as indicated in red, and returned through the venous line into the vein, as seen in blue (Fig. 1).

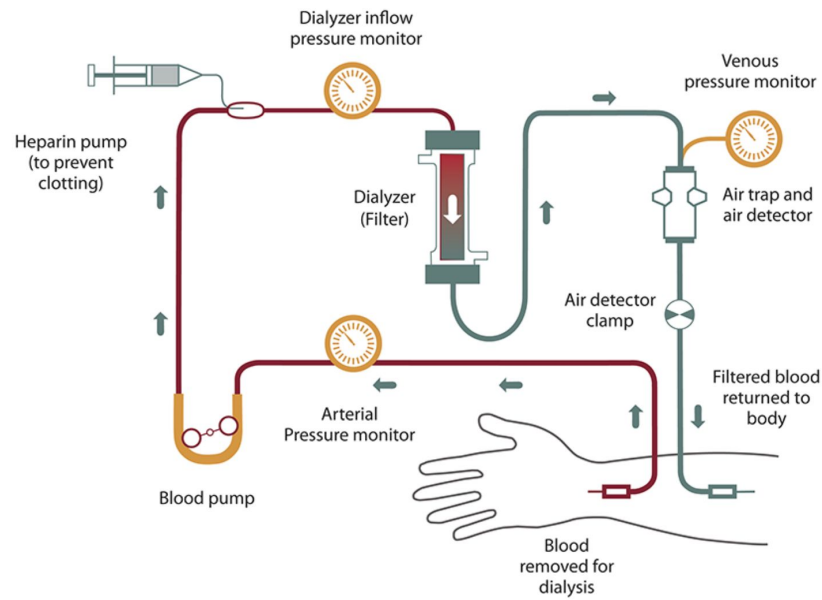
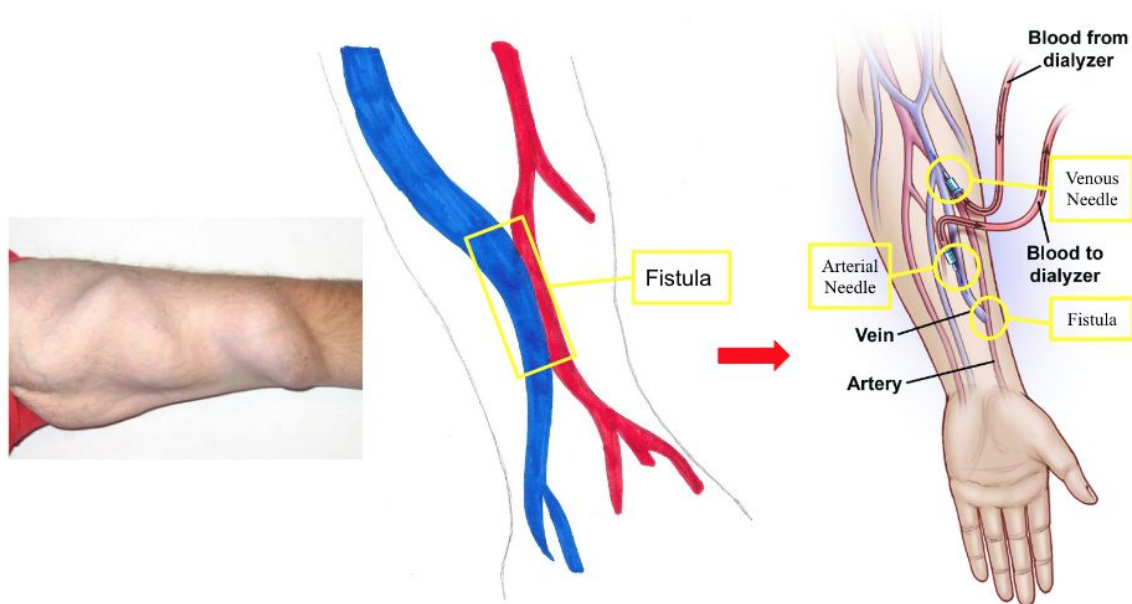

**Figure 1:** The basic process of filtering the blood through a dialysis machine. The blood is removed through the arterial line (red) and returned into the body through the venous line (blue) [10].

A patient is connected to a dialysis machine with butterfly needles to access the vein in tandem with the use of a catheter, fistula, or a graft. A catheter is most commonly used at first and over time, a fistula or a graft would be the subsequent option [9]. A fistula is the first choice for hemodialysis because of its longevity and lowest association with morbidity and mortality [10]. There are often more infectious and thrombotic complications associated with grafts and

catheters [11].

Out of the 468,000 Americans who go on dialysis every year [12], 68% have an arteriovenous (AV) fistula (Fig. 2) [13]. In order to undergo dialysis, a patient needs a very high flow of blood localized to the site of the needle insertion, which does not exist until the blood vessels are manipulated. The most effective way this is done, is by performing a surgery to connect an artery to a vein. This connection is known as an AV fistula. The AV fistula allows blood from the artery to flow faster and at higher pressures through the vein, causing the vein to become larger and stronger [14]. Thus, the vein becomes suitable for needle insertion and treatment.

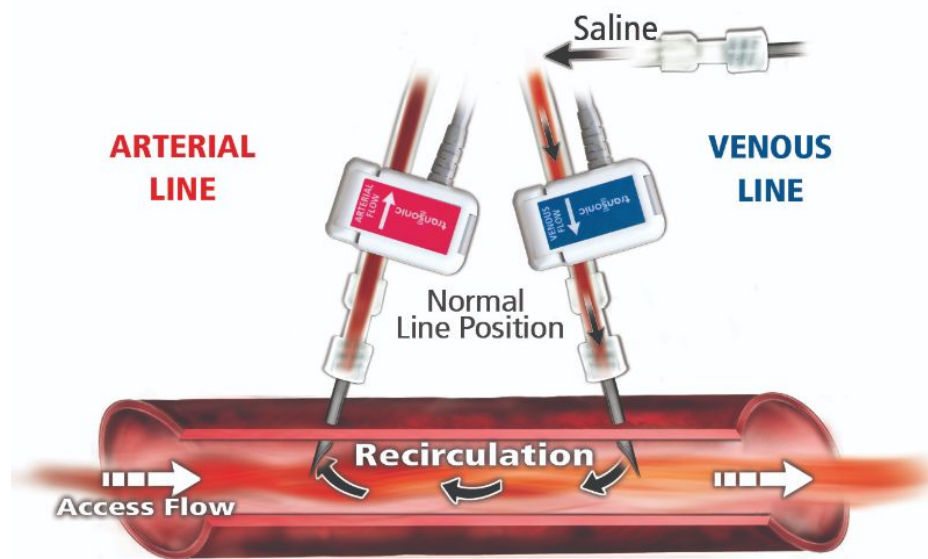

**Figure 2.** Model of how blood is circulated through the arm during hemodialysis treatment [15]. The needles are placed in the vein that has been enlarged by the fistula. The venous needle points towards the body to bring the blood back into the heart. The arterial needle points away from the body and brings the blood out of the vein to the dialysis machine [16].

One complication associated with a fistula and dialysis is access recirculation (AR).

Access recirculation results from complications in the way the blood exits the arterial needle

and returns into the vein through the venous needle (Fig. 3). The already dialyzed (cleaned) blood re-enters through the dialyzer and is cleaned again, while the rest of the patient's blood is not cleaned [10]. AR causes a decrease in dialysis efficiency, since toxins are not properly removed from the blood [17]. AR can happen to any patient, varying from treatment to treatment, as it is a problem with the current technology of the two butterfly needles used during a dialysis procedure and not with the patient. Recirculation is often identified after treatment has begun, rendering that treatment insufficient. Once dialysis has begun, it cannot be abruptly stopped once recirculation has been identified. The blood that has been removed must have significant time to return to the patient's body.

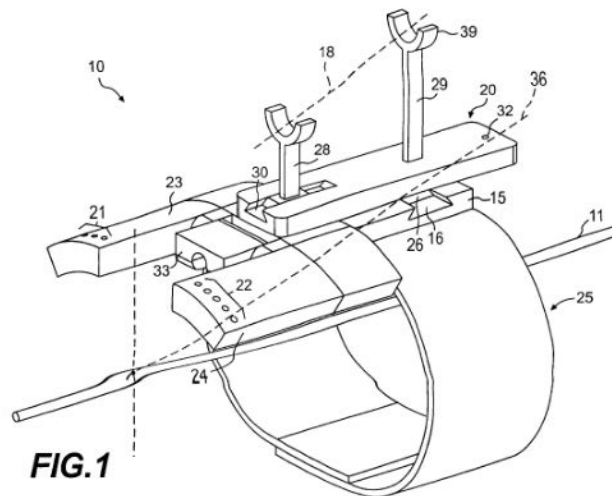

**Figure 3.** The process of recirculation occurs when blood recently cleaned by the dialyzer is recirculated through the arterial line (red), rather than passing through the circuit of the venous side [18]. The normal flow of the blood, or access flow, is towards the heart, since the blood is flowing through the vein. The abnormal blood, or recirculated blood, is traveling in the opposite direction of the normal blood flow. The recirculated blood is able to flow in the opposite direction of the normal blood flow because of different pressures and flow mechanics.

The most important cause of recirculation is when the needles are incorrectly placed, as they are often placed too close together or at the incorrect angle. There are proper parameters

that specify how to place the needles during a dialysis treatment to limit recirculation from occurring. Dialysis nurses often overlook the parameters to ensure proper placement. These parameters include placing the needles 5 to 7 cm apart from one another and having the needles remain at an angle of 20 to 35 degrees for the entirety of treatment [19].

There is no current technology to prevent access recirculation (AR), however, a method of guiding a needle into a blood vessel has been patented. The needle insertion guide apparatus is attached to the patient's arm and uses a transducer array to locate the intended blood vessel. Once the needle is positioned on the apparatus, it moves according to the transducer to ensure appropriate access to the blood vessel [20].



**Figure 4.** An apparatus to guide a needle into a blood vessel of a patient [20].

### **Problem Statement**

Access Recirculation (AR) severely decreases the efficiency of dialysis while having the potential to lead to a variety of complications (Fig. 3). If recirculation occurs during treatment, the patient may be at risk of developing stenosis (narrowing of blood vessels), leading to



thrombosis (the local coagulation/clotting of blood) [4]. The most influential cause of recirculation results from the misplacement of the arterial and venous needles that will significantly harm the patient, wasting both money and resources. It is clear that the medical community has focused their energy on developing a proactive approach to monitoring AR, instead of preventing it. Creating biomedical devices that closely monitor the occurrence of AR isn't sufficient enough. In order to prevent further complications and ensure dialysis is as efficient as possible, the goal should be to eliminate AR. **There is a clear need for a device that can be implemented during hemodialysis treatments to reduce the percentage of recirculated blood, thus, reducing the occurrence of treatment for an individual and aiding the nurses in proper needle placement.**

### **Design Objectives**

In order to create a device to reduce or eliminate recirculation, certain objectives needed to be taken into consideration. We arrived at these objectives by analyzing the current method of dialysis treatment and identifying flaws with the placement of the needles. Our design is able to fulfill these crucial objectives of usability, safety, effectiveness, and cost.

To increase usability, our device must be lightweight and comfortable for the patient. The device should be small so it remains on the patient's arm for the entirety of treatment. It should also be organized and maneuverable for the nurse placing it. Since it is easy to use, the nurses should have no difficulty accessing the vein for dialysis. The maneuverability aspect of the device will allow it to fit to a variety of differently shaped fistulas. This maneuverability also allows a patient to lift their arm during treatment without impeding dialysis or dislodging the needles.

In order for our device to be as safe as possible, it must be durable as any change in the morphology of the device during needle implementation could result in consequences for the patient. The needles must be secured to the arm since any unattended dislodgement during a treatment could result in the patient's death from blood loss, within four minutes [21]. The device has to safely guide the needles into the vein and be biocompatible on the surface of the arm. The device cannot cause the needle placement to result in an infection, clotting, or disrupt the normal fistula blood flow rates of 0.6 to 1.5 L/min [22]. The needle should also cause no disruption to the vasculature on the backside of the vein, opposite of the insertion side.

To increase the effectiveness of our device, it must decrease the percentage of recirculated blood between the arterial and venous needles. Because of the relatively cheap current technology of the cotton ball method, the cost should also be reasonable in order to ensure the device is implemented. Since there is currently no other device to eliminate recirculation, there will be no competition with other devices. The device is relatively small and should be easily produced on a wide scale.

### **Device Functions and Specifications**

To further elaborate on the objectives of our device, we needed to determine which functions were essential. Success can be determined by meeting the standards of the set objectives. Eight major functions of our device were decided upon, and are outlined in **Table 1**. The most important functions were ensuring the needles are placed at the proper distance apart from one another and at the appropriate angle. The most influential function would be eliminating confusion nurses have with needle implementation, as this is the main cause of why recirculation occurs.

**Table 1. Functions.**

1. The device safely rests on the skin.
2. The device keeps the butterfly needles stable.
3. The device keeps the proper distance between needles.
4. The device keeps the proper angle between needles and the skin.
5. The device ensures the needles maintain consistent venous outflow of blood and arterial inflow of blood.
6. The device works with current butterfly needles.
7. The device ensures the needles enter the fistula correctly.
8. The device eliminates confusion nurses have with its needle implementation.

As our goal is not to reinvent a dialysis treatment, but to instead redesign a certain portion of it, our design must meet certain specifications put in place by current technology. For these functions to be implemented correctly into our device, current specifications must be met or improved upon, as seen in **Table 2**. The most important specifications would be to place the needles 5 to 7 cm apart and at an angle of 20 to 35 degrees between the needle and the skin. The most influential specification would be ensuring the red and blue colors for the arterial and venous needles, respectively, are labeled appropriately to ensure the nurses do not place the needles incorrectly.

**Table 2. Specifications.**

1. The material will be PLA, ABS, or another biocompatible plastic [23].
2. The device keeps the entire needle inserted during the full period of dialysis treatment.
3. The needles need to be placed 5 to 7 cm apart [23].
4. There must be an angle of 20 to 35°C between the needle and the skin [19].
5. Extracorporeal blood flow rate ( $QB$ ) for children of 150 to 200 mL min <sup>-1</sup> m <sup>-2</sup> and for adults extracorporeal blood flow rate ( $QB$ ) of 200–400 mL min <sup>-1</sup> m <sup>-2</sup> , with an initial rate no less than 400 mL min <sup>-1</sup> m <sup>-2</sup> [25].
6. The device must work with butterfly needles 14 to 16 gauges [24].
7. The entire needle must enter the fistula without penetrating the other side of the vasculature [19].
8. The ends of the device which hold the needles during treatment will be color coded so the nurses place the correct needles in the proper ends of the vasculature. The arterial side will be colored red and the venous side will be colored blue.

### **Design Requirements**

The main goal for our design has been to eliminate or reduce recirculation during dialysis. According to the literature, if the distance of the two needles is 5 to 7 cm apart and the angle of insertion is between 20 to 35 degrees, little to no recirculation will occur [19]. If our device resolves these issues, our secondary focus is ensuring that the needles are securely positioned in the patient's vein.

The most important aspects of our AR prevention device includes it being easily controllable by a nurse, efficient in preventing AR, and consistent in prohibiting complications. The first requirement states that nurses must insert the arterial and venous needles at the proper distance from one another and in the proper orientation at least 80 to 85% of the time [26]. Many researchers agree that inadequate placement of the arterial and venous needles is the number one

cause of AR during hemodialysis [4, 26, 27]. It is also common for dialysis nurses to accidentally switch the venous and arterial lines, or place them at the incorrect angle, both of which significantly increase recirculation. Schneditz found that 25% of hemodialysis patients originally had their needles incorrectly placed [26]. While improper training of medical staff can be attributed to this issue, a device that does not allow the opportunity for this issue to initially arise is critical.

Another requirement is that the device must reduce the percentage of recirculated blood during a hemodialysis treatment [4]. When designing the product, the percentage of recirculated blood will be assumed to be lowered by ensuring that the needles are at the proper distance and angle. While keeping a low rate of recirculated blood is crucial for decreasing the cost and length of each specific treatment, it is also very important to consider the safety of the patient. A high rate of AR could lead to further complications, such as thrombosis or cardiac conditions, either during, or shortly after treatment [4]. It is also our hope that by increasing the efficiency of treatment, the length of treatment will decrease. While conceptually the decrease of treatment duration makes sense, there is no research to help enforce our prediction so, modeling of this system will be extremely necessary. Therefore, in order for the device to reach its full potential in regard to its effectiveness, it must limit the recirculation of blood.

Although the purpose of the device is not to improve the safety of dialysis treatment, it is crucial that the device does not introduce new health risks to the patient during treatment. In order for the current safety requirements to be maintained, an extracorporeal blood flow rate of 150 to 200  $\frac{mL}{min*m^2}$  must be preserved [Eqn. 2] [25]. Extracorporeal refers to outside the human body, or when the blood is in the needles, tubes, or dialyzer. It is important for the blood to

remain in this range of values throughout the treatment in order for the treatment to be effective and to prevent an accelerated risk of thrombosis, hypotension, or other side effects of hemodialysis [25]. It should also be noted that it is quite common for patients on hemodialysis to contract infections, due to their weakened immune system and exposed bloodstream [28]. Second to cardiovascular disease, infections are the next leading cause of death among hemodialysis patients resulting in 9.6% of these deaths among patients [30].

### **Documentation of Proposed Design**

Our proposed design is the Cannulation Pilot (Fig. 5) and it is responsible for reducing recirculation during dialysis through the elimination of user error. The inspiration for the device originates from the butterfly needles used to access the vein in dialysis. It was designed using the program SolidWorks and 3D printed as one singular piece of material. The external device is placed on the surface of the patient's arm and held to the skin using a double-sided, biocompatible adhesive. This device gives nurses a guide for needle insertion into the vein. The indent in the device allows a butterfly needle to rest securely inside, while the tape is used over the top of the needles to prevent it from moving during treatment. The Cannulation Pilot will hold the butterfly needles at a 30 degree angle and at a distance of 6.5 cm apart from one another when a nurses are accessing the vein for treatment.

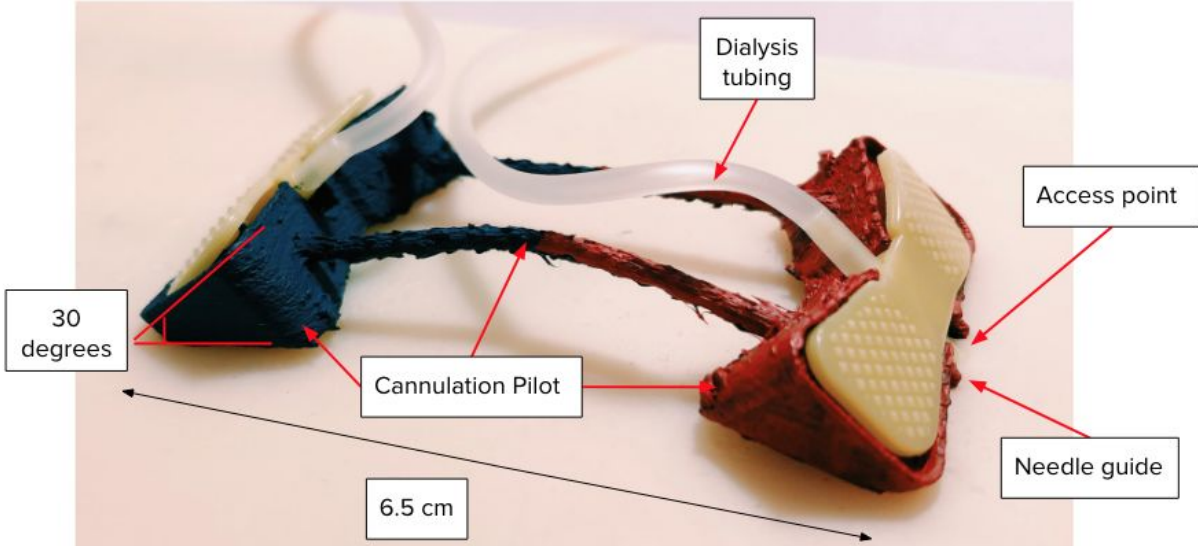

**Figure 5.** Cannulation Pilot with Needle and Injection Pad. The butterfly needle is placed into the device and held at a 30 degree angle during treatment. It will rest on the surface of the patient’s skin and prevent recirculation from occurring.

The Cannulation Pilot is composed of two butterfly-shaped pilots. These two pilots will face in opposite directions from each other and connect in the middle. The flexibility of the central connection allows for the device to maneuver and fit to various fistulas. To limit recirculation, the needles must access the vein at an angle of 20 to 35 degrees and a distance of 5 to 7 cm apart [19]. Since the Cannulation Pilot is responsible for holding the needles at a 30 degree angle and at a fixed distance of 6.5 cm apart from each other, no recirculation should occur. In order to differentiate between the arterial needle and venous needles, the pilots will be colored red and blue, respectively (Fig. 5).

The needles will slide over the pilots as they enter the vasculature and are placed in the pilots to maintain stability during treatment, eliminating the use of unnecessary cotton balls. The pilots will be held down by a double-sided biocompatible adhesive. The current adhesive

used is an electrode and will be changed if a more efficient adhesive is discovered. Because the device is small and relatively cheap to manufacture, it will likely be disposable after one use. The material currently used for the Cannulation Pilot is a flexible TPE material. The flexible material was used to insure that our device could bend to various fistula shapes and sizes.

### **Validation of the Design**

While we have no way of testing the exact amount of recirculated blood prevented using our device, simply placing the needles at the correct distance and angle will reduce or eliminate AR [19]. In order to validate the success of our device, we will test that the parameters hold true regardless of the environment where the device is placed. To evaluate the functions of the Cannulation Pilot, five tests will be performed. The tests include measuring the stability of the device, the consistency in defining the distance between both access points, the accuracy in ensuring the correct angle of the needle insertion, the adaptation to various fistulas, and the “stickiness” of the device.

To test the stability of the device, an orbital shaker was used. We inserted the needles into an injection pad using our device and placed it onto the shaker. The orbital shaker then agitated the system, providing disturbances to the needles and the device. We “shook” the system for five minutes and observed any disturbances. This shaker test was done a total of five trials. If the needles slipped or moved in any way, we would have adjusted the device. This test was meant to represent any external forces putting pressure on the system during treatment.

In order to evaluate the distance between the two access points, we inserted the needles into the injection pad using our device, the current method, and just the butterfly needles. The distance test was done for ten trials each. Since the connection between the two pilots of our



device is flexible, we bent it to the greatest degree possible in some trials, while keeping it unbent in others. For each trial, we used a ruler to measure the direct distance between the two insertion points. While it is understood that this number may not be ideally consistent due to the bending of our device, the total distance must be between an acceptable range of 5 and 7 cm.

Similarly to the distance test, to test the proper needle angle, the arterial and venous needles were placed into the injection pad with our device, the current method, and just the butterfly needles. The current method involves inserting the needle into the injection pad and holding the needles at an angle using the cotton balls. We inserted the needles into the injection pad ten times for each system and measured the angle of each trial. Our device must accurately depict the ideal angle placement of 20 to 35 degrees and be consistent for all ten trials. We compared the results of the angle between the Cannulation Pilot, the current method and using simply the butterfly needles. In order for AR to be reduced, the angle of placement must be accurate and exist within the range of 20 to 35 degrees.

Fistulas arise in a variety of unpredictable shapes and sizes. In order for our device to be universally effective, it must adapt to each one. As a result, the middle connection of our device was made to bend accordingly. We cut portions of the foam out of the silicone-foam injection pads to mimic the shape of two fistulas, purposely creating ones that are excessively big or oddly shaped. In order to move forward with our device, it was necessary that it could be manipulated to fit onto each fistula without resistance or the tendency to “bend back” into its original structure.

Dialysis treatment typically lasts four hours and it is necessary that our device will not fall off or move for the entirety of the treatment. The external pressure on the two needles could

be unsafe for the patient. In order to prevent this, our device will “stick” to the patient by attaching electrode-like layers to the bottom of the pilots. In order to evaluate the “stickiness” of the device, we stuck the device to an injection pad and inverted it. The inversion was held for 60 seconds and was performed five times. If the device fell or moved on the injection pad during the 60 second time span, we would have adjusted our device. Although dialysis treatment is typically four hours, the inversion will accurately assess our device.

The results of our validation tests supported the success of the Cannulation Pilot (Table 2). Although the average distance for the distance test for both the needle method and the cotton ball method were within the 5 to 7 cm range, the results were biased since the experimenters had a ruler to reference the proper distance. The standard deviation for both the cotton ball method and needle method was above 1 cm, which is too variable for a clinical setting. The angle test for the needle method was below the ideal angle range and the cotton ball method was above the ideal angle range of 20 to 35 degrees. For both the distance and the angle tests, the Cannulation Pilot was successful. The various fistulas test and the shaker test were successful for all three methods, proving that our device can bend a full 180 degrees to adapt to various fistulas, as well as hold the needles stable regardless of external forces. The inversion test was unsuccessful for the current cotton ball method since the needles did not remain in the patient’s arm. Our device, however, kept the needles secure. The Cannulation Pilot could, therefore, ensure more patient movement throughout treatment without the movement of needles.

**Table 3. Validation tests results (Imaging in Appendix D).**

<i>Test</i>	<i>Results</i>	<i>YES/NO</i>
Distance test w/out device	Average: 6 cm; SD: 1.05 cm	✗
Distance test w/ cotton balls	Average: 6.1 cm; SD: 1.08 cm	✗
<b>Distance test w/ device</b>	<b>Average: 6.5 cm; SD: 0 cm</b>	✓
Angle test w/out device	Average: 14.4 degrees; SD: 4.39 degrees	✗
Angle test w/ cotton balls	Average: 41.4 degrees; SD: 3.51 degrees	✗
<b>Angle test w/ device</b>	<b>Average: 30 degrees; SD: 0 degrees</b>	✓
<b>Various fistulas test</b>	<b>Rotation range: 180 degrees</b>	✓
<b>Inversion test</b>	<b>Time: 60 sec.; Disruption: No</b>	✓
<b>Shaker test</b>	<b>Time: 60 sec.; Disruption: No</b>	✓

### Anticipated Regulatory Pathway

Venous dislodgement during dialysis can be life-threatening. To prevent any risk of venous needle dislodgement during treatment, the needles and lines need to be properly taped. There are several different types of medical tape that exist, however, the most common type that is used specifically for anchoring the needles during dialysis is Micropore [31]. Other predicate devices such as silk, paper, or transparent medical tape may be used if a patient is allergic to Micropore. An example of Micropore is the Microporous Medical Adhesive Tape. The Microporous Medical Adhesive Tape is a breathable tape with both a porous backing layer and a microporous adhesive layer [32]. The nurses are required to use this medical tape to secure the needles to the patient’s arm. The needles must be secured in place to prevent accidental dislodgement or movement of the needles after they have been accessed. If the tape is improperly used and the needles move within the fistula, poor blood flow or needle infiltration could occur

[19]. According to the FDA, Microporous Medical Adhesive Tape was deemed “Substantially Equivalent (SESE)” and was proven to be as safe and effective as the predicate [33].

**Table 4. Analysis of 510(k) premarket notification [33].**

<i>Device Name</i>	Microporous Medical Adhesive Tape
<i>510(k) number</i>	K840447
<i>Applicant</i>	Lectec Corporation
<i>Classification Product Code</i>	KGX
<i>Regulation Description</i>	Medical adhesive tape and adhesive banda
<i>Review Panel</i>	General Hospital
<i>Regulation Number</i>	880.5240

The differences that the Cannulation Pilot might encounter in comparison to the FDA cleared device, the Microporous Medical Adhesive Tape, would be ensuring the safety and the biocompatibility of the pilot component itself. Although the electrodes are used to keep the device attached to the patient’s arm, it must be ensured that the device will not cause any harm to the patient. Since there is no device similar to the Cannulation Pilot itself, the process of approval from the FDA may not be as simple as a substantial equivalence. Moving forward, the Cannulatin Pilot would need to be made out of a biocompatible material to ensure the safety of the dialysis patients.

## References

- [1] Acute Kidney Injury (AKI). (2016). *National Kidney Foundation*.
- [2] Kidney Disease Statistics for the United States. 2016.
- [3] Jablonski, Kristen L., and Michel Chonchol. "Recent Advances in the Management of Hemodialysis Patients: A Focus on Cardiovascular Disease." *F1000Prime Reports*, 2014: 72. *PMC*. Web. 2018.
- [4] Salimi, Javad, et al. "Predicting Hemodialysis Access Failure with the Measurement of Dialysis Access Recirculation." *Saudi Journal of Kidney Diseases and Transplantation*, 2008.
- [5] National Kidney Foundation. 2015.
- [6] Sinnakirouchenan, Ramapriya, and Jean L. Holley. "Peritoneal dialysis versus hemodialysis: risks, benefits, and access issues." *Advances in chronic kidney disease*, 2011: 428-432.
- [7] National Kidney Foundation. 2017.
- [8] Kolonko, Catherine. "Why is Peritoneal Dialysis Underutilized the US Compared to Hemodialysis?" *eMedicineHealth*, 2012.
- [9] Hall YN, Larive B, Painter P, et al. Effects of six versus three times per week hemodialysis on physical performance, health, and functioning: Frequent Hemodialysis Network (FHN) randomized trials. *Clinical Journal of the American Society of Nephrology*, 2012:782–794.
- [10] Santoro, Domenico, et al. "Vascular access for hemodialysis: current perspectives." *International journal of nephrology and renovascular disease*, 2014: 281.
- [11] <http://dialysis-patient-care.blogspot.com/2010/11/>
- [12] End Stage Renal Disease in the United States. *National Kidney Foundation*, 2016.
- [13] Pisoni, Ronald L. et al. "Trends in US Vascular Access Use, Patient Preferences, and Related Practices: An Update From the US DOPPS Practice Monitor With International Comparisons," *American Journal of Kidney Diseases*, 2014: 905 - 915.
- [14] "Everything You Need to Know About an Arteriovenous Fistula." Azura Vascular Care, InfoDialysisAccess, 2017.
- [15] "US Versus the World on Vascular Access Trends: Where Do We Stand?." *AJKDblog*.
- [16] "HealthJade." <http://healthjade.com/arteriovenous-fistula>
- [17] Mahbub, T., Chowdhury, M. N. U., Jahan, F., Islam, M. N., Khan, F. M., Sikder, N. H., &

- Rahman, M. Factors responsible for increased percent recirculation in arteriovenous fistula among the haemodialysis patients. *Bangladesh Medical Research Council Bulletin*, 2013: 28-33.
- [18] Miller, L. M., Clark, E., Dipchand, C., Hiremath, S., Kappel, J., Kiaii, M., ... on behalf of the Canadian Society of Nephrology Vascular Access Work Group. Hemodialysis Tunneled Catheter-Related Infections. *Canadian Journal of Kidney Health and Disease*, 2016.
- [19] Brouwer, Deborah J. "Cannulation camp: basic needle cannulation training for dialysis staff." *Dialysis & Transplantation*, 2011: 434-439.
- [20] Staehlin, John H., and Guy Rubley. "Needle insertion guide apparatus and method." U.S. Patent No. 6,283,942. 2001.
- [21] Fields, Robin. "When Needles Dislodge, Dialysis Can Turn Deadly." *ProPublica*, 2010.
- [22] Narechania, Shraddha & Tonelli, Adriano. "Hemodynamic Consequences of a Surgical Arteriovenous Fistula." *The Clinical Psychologist*, Internal Medicine Residency, Fairview Hospital, Cleveland, Ohio.
- [23] Rimington, Rowan P., et al. "Biocompatible 3D printed polymers via fused deposition modelling direct C 2 C 12 cellular phenotype in vitro." *Lab on a Chip*, 2017: 2982-2993.
- [24] Clinical Update: Needles and Cannulas For Arteriovenous Fistula Access. *National Kidney Foundation*, 2016.
- [25] Fischbach, M. et al. "Hemodialysis in Children: General Practical Guidelines." *Pediatric Nephrology (Berlin, Germany)*, 2005: 1054–1066. *PMC*. Web. 2018.
- [26] Schneditz, D. "Recirculation, a seemingly simple concept." *Nephrology, dialysis, transplantation: official publication of the European Dialysis and Transplant Association-European Renal Association*, 1998: 2191-2193.
- [27] Mousavi, SS Beladi, et al. "Arterio-Venous fistula recirculation in hemodialysis: causes and prevalences." *Shiraz E Medical Journal*, 2010: 219-224.
- [28] "Dialysis Safety." *Center for Disease Control and Prevention*.
- [30] Kliger, Alan S. "Maintaining safety in the dialysis facility." *Clinical Journal of the American Society of Nephrology*, 2015: 688-695.
- [31] Doyle, Teresa. "Venous Needle Dislodgement." *Renal Patient Information Group*, 2017.
- [32] Cilento, Rudolfo D., Charles Riffkin, and Anthony L. LaVia. "Microporous adhesive tape."

U.S. Patent No. 4,427,737. 1984.

[33] “510(k) Premarket Notification.” U.S. Food and Drug Administration, 2019.

## Appendix A

### AMC Visit Notes

- I. AMC visit
  - A. Thursday, January 17th under supervision of Dr. Smith
  - B. We took a rough prototype of the cannulation platform with us to AMC. The rough prototype was to allow the nurses to better understand our device and to better conceptualize how our device would fit on a patient. The purpose of this visit was mainly to gather suggestions about modifications to the device.
  - C. We had a list of questions we came up with in class that day to make sure we asked the nurses about
    1. Curvature and location of vein
    2. Visual - device being transparent
    3. Needle security - straps for the device
    4. Hole size and placement (algorithm)
    5. Children vs. adults
- II. AMC discussions
  - A. We started off by explaining our capstone project and how we are trying to build a device to help eliminate recirculation from occurring during dialysis. We showed them our design and one of the nurses placed it on her arm. We asked them all our questions in regards to our device. We learned the fistula may not be on the lower arm and is often placed on the upper arm. The fistula may be different shapes (not universal) and depends on how vascular surgeon performs surgery. They liked the comfort aspect of the padding on the straps and the adjustability to account from arm swelling. The problem with the strap would be patients removing it during treatment.
  - B. Discussion with Dr. Monrroy
    1. We explained our design and he told us the rule of maturation for a fistula is 6mm wide/long/deep. He told us to avoid the devices in the vein and to stay on the surface to avoid thrombosis problems. The main issue we learned was finding the fistula, especially in patients who are obese. We visited three different patients to see and feel their fistulas. We learned that our device wasn't going to work. Our ideas were going in the right direction and needed to be modified.



## Appendix B

### Evolution of Previous Designs

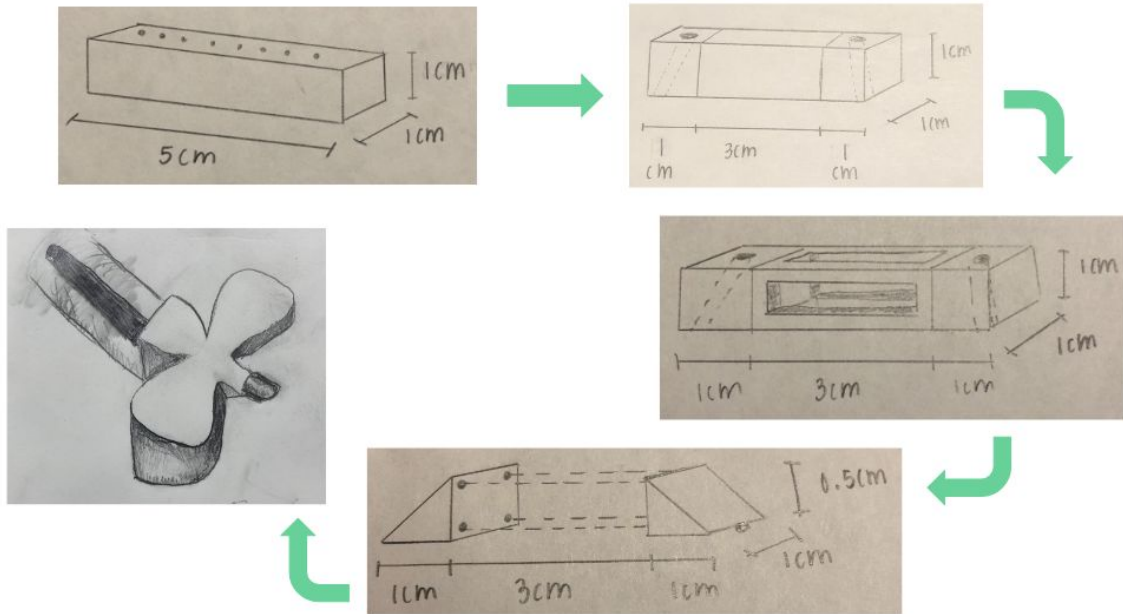

**Figure 6.** Our first design started off as a simple rectangular shape. With trial and error, we started to use less material and change the shape. The final prototype was inspired by the butterfly needle used for dialysis.

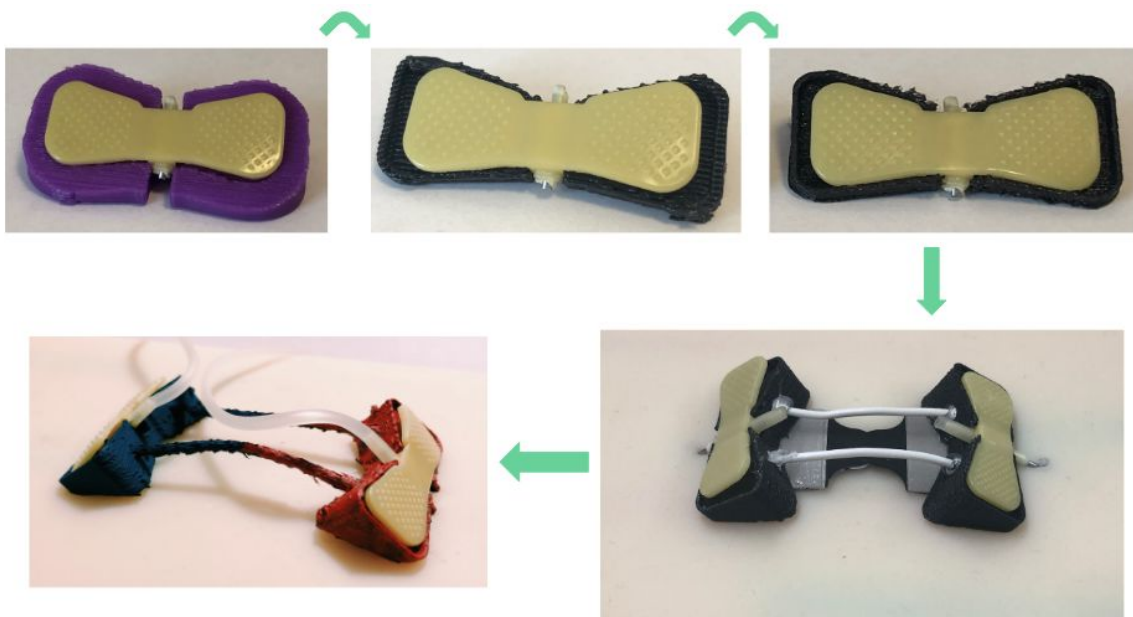

**Figure 7.** Our 3D printed prototypes were created by outlining the edges of the butterfly needle. The device evolved from two separate pilots connected by a flexible wire to one singular device.

## Appendix C

### Helpful Materials

Material	Price
Medical Tape	\$8.99
Velcro	\$4.91
Needle Injection Pad	\$25.99
16 Gauge Needles	\$9.32
Butterfly Needles	\$40.22
Silicone and Sponge Injection Pad X2	\$27.98
Electrodes	\$8.85
Double Sided Foam Tape	\$7.99
X-Acto Knife	\$7.31

## Appendix D

### Validation 1: Shaker Test



### Validation 2: Distance Test

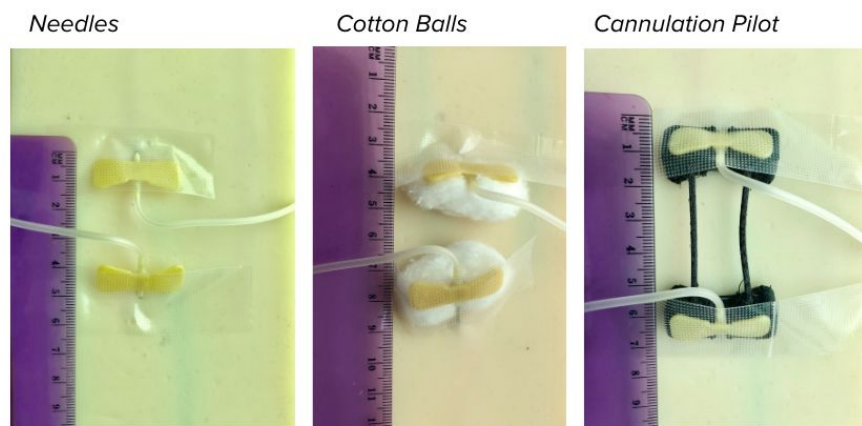

### Validation 3: Angle Test



**Appendix E**

**Validation 4: Various Fistulas Test**

Fistula 1:

*Needles*



*Cotton Balls*



*Cannulation Pilot*



Fistula 2:

*Needles*



*Cotton Balls*



*Cannulation Pilot*



**Validation 5: Inversion Test**

*Needles*



*Cotton Balls*

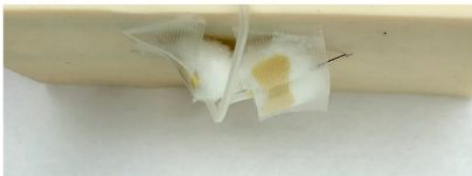

*Cannulation Pilot*

