

6-1982

# Microcomputer interfacing with chemical instrumentation

Joel R. Meyer

*Union College - Schenectady, NY*

Follow this and additional works at: <https://digitalworks.union.edu/theses>



Part of the [Chemistry Commons](#)

---

## Recommended Citation

Meyer, Joel R., "Microcomputer interfacing with chemical instrumentation" (1982). *Honors Theses*. 1884.  
<https://digitalworks.union.edu/theses/1884>

This Open Access is brought to you for free and open access by the Student Work at Union | Digital Works. It has been accepted for inclusion in Honors Theses by an authorized administrator of Union | Digital Works. For more information, please contact [digitalworks@union.edu](mailto:digitalworks@union.edu).

MICROCOMPUTER INTERFACING WITH  
CHEMICAL INSTRUMENTATION

by

Joel R. Meyer  
"

\*\*\*\*\*

Submitted in partial fulfillment  
of the requirements for  
Honors in the Department of Chemistry

UNION COLLEGE

May, 1982

Special thanks to T.C. Werner and L. Hull for  
their help and support throughout this project.

Dedicated to Regula Frey

TABLE OF CONTENTS

Abstract .....	-1-
Introduction .....	-2-
Section I: Instrumentation .....	-4-
A) HPLC .....	-4-
B) Fluorescence Spectrophotometer .....	-5-
C) A/D + D/A Converter .....	-6-
D) Operational Amplifiers .....	-11-
1) HPLC .....	-11-
2) Fluorometer .....	-14-
Section II: Software .....	-19-
1) Menu .....	-19-
2) Interrupter .....	-22-
3) Plot .....	-33-
A) HPLC - Chromatograms .....	-33-
B) Fluorometer - Emission Spectrum .....	-41-
4) Integration .....	-46-
5) Baseline Adjust .....	-52-
6) Load Data Files .....	-54-
Discussion .....	-57-
Appendix .....	-61-
References .....	-60-

MEYER, JOEL Microcomputer Interfacing With Chemical Instrumentation. Department of Chemistry May 1982.

In this paper we discuss the interface of a liquid chromatograph with an Apple II+ microcomputer. The system consists of a Varian 5000 High Performance Liquid Chromatograph (HPLC), a Tracor 970A variable wavelength absorption detector (VWD), an Apple II+ computer, and an interface unit which consists of an operational amplifier and a Mountain Computer A/D + D/A converter. The op. amp. modifies the output signal of the VWD (0 to +1V) to meet the input specifications of the A/D converter (-5V to +5V). This allows the conversion of the continuous analog signal from the VWD to a digital signal, which is required by the Apple. The system produces chromatograms (digital absorption equivalent value vs. time) using the high resolution graphics screen of the Apple, which can be printed with an Epson dot matrix printer. Further, it calculates retention times, performs peak integration, and prints out the results from these operations. A comparison of the Apple's integration with standard cut-and-weigh as well as triangle approximation methods gives an indication of the reliability of the integration technique.

A manual, which requires that the user have only minimal computer experience, has been written to facilitate user access to the system.

This project involves interfacing an Apple II+ microcomputer with two different laboratory instruments: a Varian 5000 High Performance Liquid Chromatograph (HPLC) and a Perkin-Elmer MPF-2A Fluorescence Spectrophotometer (FS). The interface systems are quite similar, in that both involve modifying an analog signal to meet the input specifications of Mountain Computer's A/D + D/A converter, which converts the analog signal to a digital signal. Using Apple BASIC and assembly language, we can store the digital signal in successive memory locations of the Apple as a function of time. The digital absorbance equivalent signal may then be plotted as a function of time for the HPLC and the digital fluorescence equivalent as function of wavelength for the FS, to produce a chromatogram and a fluorescence spectrum, respectively. In addition, the system performs relative and absolute integrations and makes hard copies of the processed data using an Epson dot matrix printer.

The schematic below (Figure 1) represents the pathway of a signal from the real world through the interface unit, which consists of the necessary operational amplifiers and the A/D converter, and into the Apple. This paper will explain the different steps in the modification and processing of the data signal

Figure 1 - Schematic

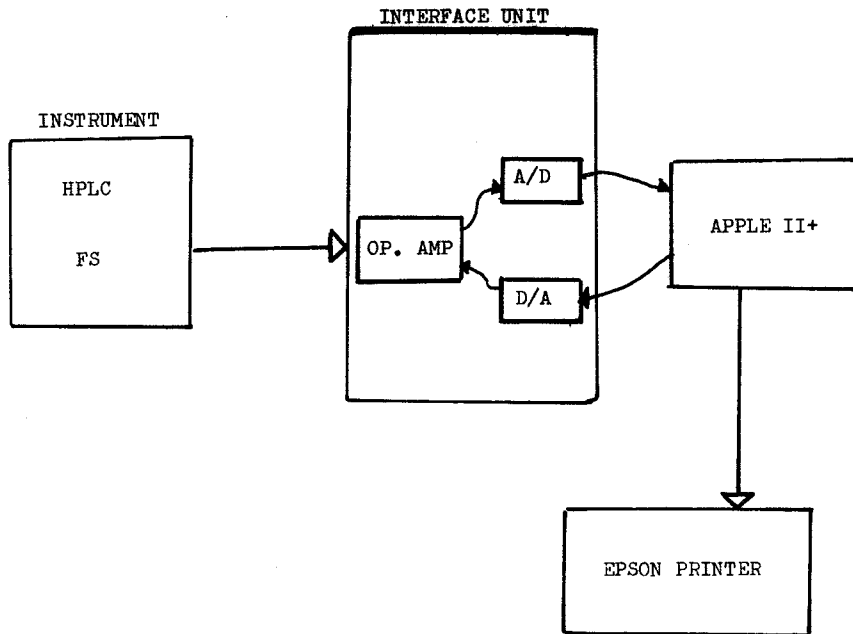

obtained from the various instruments. Parts of the interface system will be analysed in the order that the signal passes through them, except for the A/D + D/A converter. An understanding of this unit is necessary in order to follow the design considerations for the op. amps. For this reason, it is appropriate to consider this part of the system after the description of the apparatus in section 1. In addition, since most of the analysis is quite similar for the two instruments, the bulk of the analysis will be done with respect to the HPLC, and the essential considerations for the FS system will be dealt with in a separate section.

#### Section I: Instrumentation

##### A) HPLC

The HPLC setup consists of a Varian 5000 HPLC and a Tracor 970A variable wavelength absorption detector (VWD). The VWD has an analog output, in addition to the output used for the recorder, which is specifically designed for interfacing. The range of this output is from 0 to 1V. The analog signal is not a function of the Absorbance setting on the TRACOR 970A, which is commonly used to amplify the output signal to the recorder. This is convenient, because the signal to the HPLC op. amp. will thus always be confined to the same range. This simplifies the design of op. amps. needed



to modify the analog signal to the specifications of the A/D converter. The design of the op. amp. will be discussed after the discussion of the A/D + D/A converter.

#### B) Fluorescence Spectrophotometer

This instrument consists of a xenon power supply, a power unit, a spectrophotometer, and a recorder. An output analog signal is found on the back of the spectrophotometer, but, unlike with the HPLC, this signal's range is a function of the Sensitivity setting (analogous to the absorbance setting on the HPLC) on the spectrophotometer power supply. Instead this range varies with changes in the sensitivity setting, since these range changes are controlled by switching resistors in the feedback loop of an amplifier in the spectrophotometer power supply. It is possible to construct a circuit that has a constant output range at the different sensitivity settings. The circuit contains a five pole switch which offsets the changing sensitivity adjustment on the power supply. Further, it is advantageous to design this circuit so that the output range is 0 to 1V. This way, the op. amp. designed for the HPLC can be used for the final modification of the output analog signal, making the range acceptable to the input specifications of the A/D

converter. The design for the fluorometer's first op. amp., as well as the HPLC's op. amp., will be shown in the section on operational amplifiers.

#### C) A/D + D/A Converter

As mentioned previously, it is important to understand the specifications for this piece of hardware in order to understand the design strategy of the operational amplifiers. It is for this reason that we discuss this part of the interface prior to a discussion of op. amps.

Mountain computer's A/D + D/A board can be purchased as a unit, which includes the actual board and two blue twenty five pin ribbon cables. The unit fits conveniently into one of the slots in the Apple. Installation is relatively straightforward and instructions are included in the A/D + D/A operating manual(1), which comes with the unit. In addition, Mountain Computer supplies a demonstration diskette which consists of several sample applications and a self test for the board. Running the self test program determines whether or not all parts of the A/D + D/A board are "functional and properly installed." A complete description of Self Test can be found in the A/D + D/A manual(2).

The A/D + D/A board functions within a specific

voltage input range. The board converts a continuous analog signal, from -5V to +5V, to a discrete digital signal, ranging from 0 to 255. At input voltages outside this range, the board gives the upper or lower limit of the digital scale depending on whether the analog signal is greater than +5V or less than -5V. Below is the chart (Table 1) included in the A/D + D/A manual, which illustrates A/D as well as D/A conversion.

It is important to note that the digital values produced by the ADC are subject to certain performance factors. That is, the board is functioning properly as long as the absolute deviation for the full scale reading is within +/- 3% and the relative deviation is +/- 1 for the least significant bit. Also worthy of mention is the fact that the ADC only uses addresses in memory between \$C090 and \$C0FF. These addresses, expressed in hexadecimal code, correspond to a range of 49,296 to 49,407 in decimal code. The significance of this will be explained in the section on memory usage. Finally, the conversion from analog to digital requires nine microseconds. This represents the fastest time that an analog signal can be monitored using the ADC.

The unit also includes two twenty five pin ribbon cables which are used as the input and the output of the A/D and D/A converter. The pin plan included in the manual for these two cables is incorrect;

Table 1 - A/D + D/A Conversion Chart

A/D + D/A Conversion Chart

(Output) DAC	Number	(Input) ADC
-5.00 V	0	-5.00 V
	.	
-2.50 V	64	-2.50 V
	.	
0.00 V	128	0.00 V
	.	
+2.50 V	192	+2.50 V
	.	
+5.00 V	255	+5.00 V

therefore, we show the corrected plan in Figure 2. It is worthy of note that each plug has 15 channels (0-14) for conversions, 8 grounds, and 2 nonsense channels. Furthermore, the plugs are mirror images of each other, which greatly simplified the correction of the outdated pin plan.

The manual for the A/D + D/A board also includes instructions on how to read a particular channel for the ADC and how to program a particular channel for the DAC. Since these instructions would be more useful when presented with the software for data collection, the analysis is not repeated here.

Figure 2 - Corrected Pin Plan

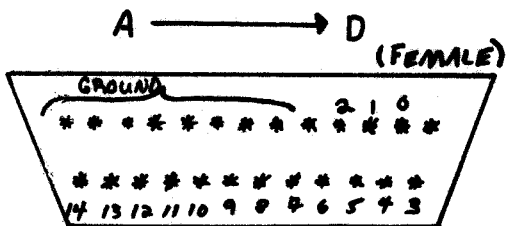
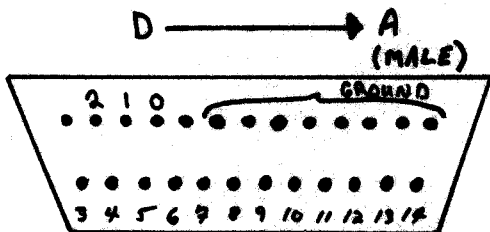

## D) Operational Amplifiers

### 1) HPLC

In general, there are three important rules to remember when working with op. amps.:

1) They have a high input impedance as well as a low output impedance.

2) They always act to keep the potential difference between their two inputs, inverting and non-inverting, equal to zero.

3) Their output voltage depends only on the external connections to the op. amp.

With these rules in mind, we proceeded to make the output signal from the VWD compatible with A/D converter's input specifications. Recall that the optimum voltage range for the ADC is -5V to +5V, and that the output of the VWD varies from 0V to 1V. The modification, therefore, involves an amplification as well as an offsetting of the output signal from the VWD. More precisely, the output signal from the VWD must be amplified by a factor of 10 and offset with a constant -5V. This would convert the output voltage range of the VWD to the optimum input voltage range for



the ADC. An op. amp. circuit that performs this conversion is shown in Figure 3. The circuit consists of two op. amps. and various resistors. The first op. amp. has two input voltages that intersect at the inverting input of amp. 1. These are the output voltage from the W/D,  $E(i)$ , and an offset voltage of  $-5V$  from the DAC. The output voltage of the first op. amp.,  $E(1)$ , depends on the external connections to the amp. in the following manner:

$$E(1) = -(E(i)(R3/R1) + (-5V)R2/R1) \quad (1)$$

This can be simplified by plugging in the values of the various resistors as follows:

$$E(1) = -(10E(i) - 5V) \quad (2)$$

The second op. amp. in the circuit functions as an inverter, and its output,  $E(2)$ , depends on  $E(1)$  and the external resistances in the following way:

$$E(2) = -(E(1)R5/R4) \quad (3)$$

Simplifying this equation, we obtain the following:

$$E(2) = -E(1) \quad (4)$$

FIGURE 3 - HPLC Operational Amplifier

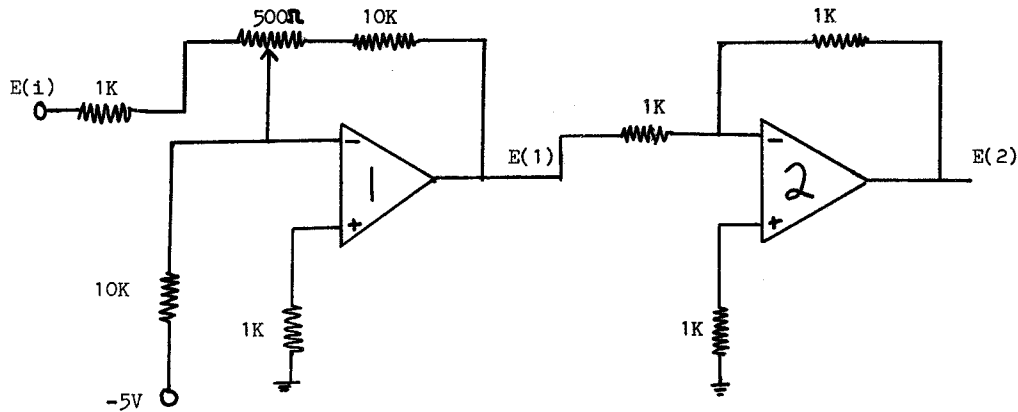

$$E(1) = -(10E(i) - 5V)$$

$$E(2) = -E(1)$$

Using these equations, it is clear that an input voltage,  $E(1)$ , at op. amp. 1 of 0V will produce an output voltage,  $E(2)$ , at op. amp. 2 of -5V. Similarly, if  $E(1)$  equals +1V then  $E(2)$  will have a value of +5V.

In order to test the reliability of this op. amp., we simulated the input voltage from the VWD using the DAC. That is, using the DAC as a source of a variable DC voltage, we varied the input voltage,  $E(1)$ , from 0 to 1V and recorded the resulting output voltage,  $E(2)$ . A plot of Output Voltage vs. Simulated VWD Voltage shows the linearity of the signal modification by the op. amp. (Fig. 4)

## 2) Fluorometer

As mentioned previously, the output analog signal from the fluorometer has a range that varies with different sensitivity settings on the fluorometer. To design an op. amp. for this instrument, it was therefore necessary to vary the resistance in the feedback loop of the amp. such that the ratio of  $R(f)$  to the input resistance offsets the change in the output signal of the fluorometer due to a change in sensitivity. An op. amp. that performs this conversion is shown in Figure 5. The equation that represents the behavior of this op. amp. is as follows:

Figure 4 - Linearity of HPLC Op. Amp.

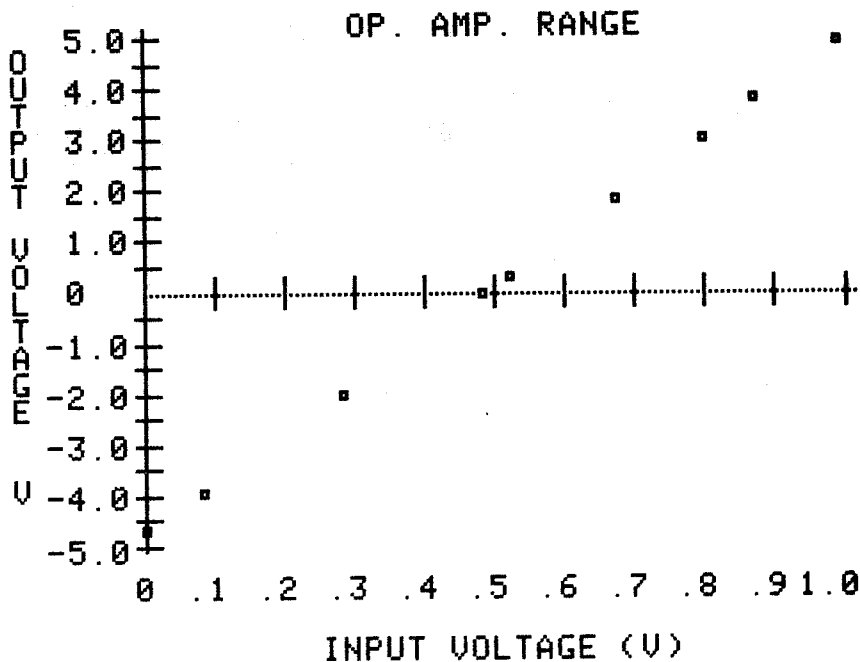

$$E(1) = -E(i)R(f)/30K \quad (5)$$

It is important to note that, although there are actually six sensitivity settings on the spectrophotometer power supply, the op. amp. is designed to accomodate only the sensitivity settings from one to five. The decision to exclude sensitivity six from our op. amp. design was based on the fact that this setting is never used.

It is necessary to adjust the Sensitivity and Zero settings on the fluorometer for each experiment. The user must connect a voltmeter to the output signal from the op. amp. and monitor this voltage in order to adjust the output range using these two settings. Ideally, the user will try to adjust the maximum emission, at a particular wavelength, so that it corresponds to a voltage output of approximately 1V. Likewise, the baseline, which is obtained when the Filter setting is on S, should be adjusted so that its voltage is approximately zero volts. This will be more clearly explained in the user's manual.

Practically speaking, the output signal of the interface op. amp., after inversion, varies from 0 to 1V when the interface op. amp. sensitivity matches that of the fluorometer. With the signal confined to this range, the output of the interface op. amp. is fed into

Figure 5 - Fluorometer Op. Amp.

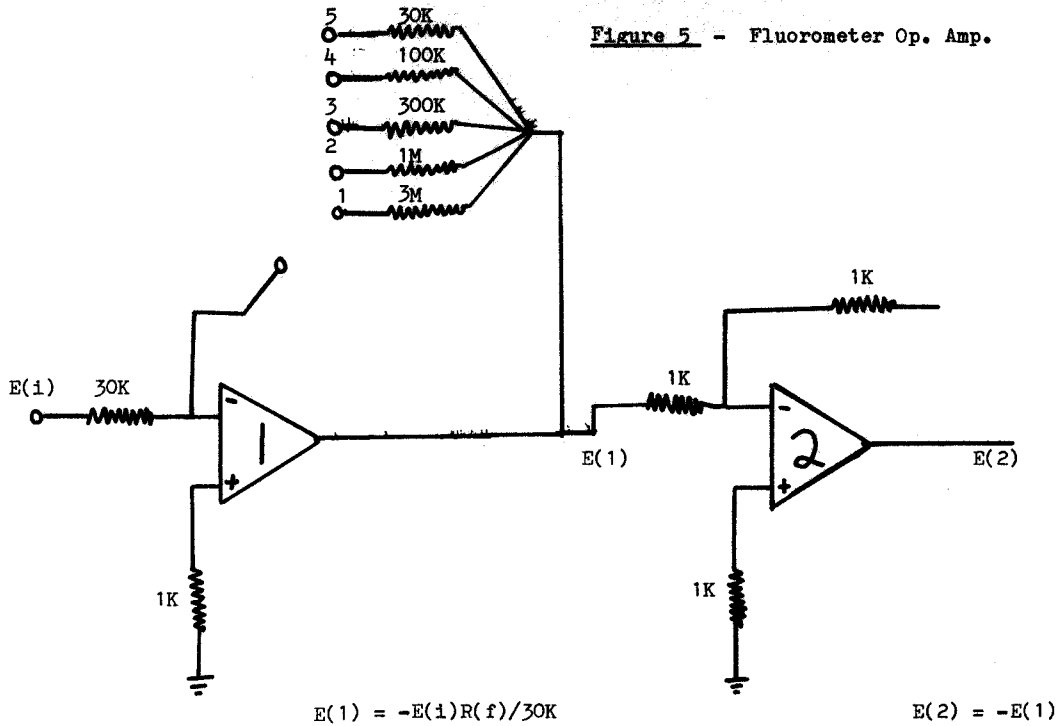

-18-

the input of the HPLC op. amp. Recall that the HPLC op. amp. changes a 0 to 1V signal at its input to a -5V to +5V output signal compatible with the ADC.

## Section II: SOFTWARE

This section describes the different computer programs necessary to process the discrete digital signal from the ADC. Since the programs are essentially the same for the fluorometer and the HPLC interface systems, we will present them only for the latter. Any important modifications made for the fluorometer interface system will be mentioned at the end of a particular program's description. It is important to note that most of the software, excluding the binary files used in the Interrupter program which were written in assembly language, was done in Apple BASIC. For a review of Apple BASIC the reader is referred to the Basic Programming Reference Manual. (3)

Programs will be analysed in the order that they would be used during an experiment. In addition, we will not go into a great deal of detail about the aesthetics of programming, i.e. how printouts were aligned and organized, nor will we attempt to analyse every step of each program. Rather, the function of each program, as well as the use of interesting Apple BASIC commands will be discussed.

### 1) Menu

The purpose of this program is to make the interface system accessible to the user. In short, the



program allows the user to run one of six different programs that are stored on the interface diskette. The program prints a menu on the high resolution graphics screen of the Apple which presents the user with six different choices. This is accomplished using six "print" statements with the title of a particular choice in quotation marks following "print".(Table 2) The program communicates with the user in line 150 with an "input" statement that asks the user to select one of the choices by entering the number corresponding to a particular choice. In lines 180 - 207 the program makes use of the "On ...Gosub" statement which tells the Apple where in the program it should proceed when a choice is selected. In this case, the first five choices tell the computer to run a specific program stored on diskette. The sixth choice results simply in termination of the program.

The interesting aspect of this program is that it uses the CHR\$(4) command of Apple BASIC. This command allows instructions for the computer to be left within a program in the same format as these instructions would be entered by a user. In this program (line 250), note that the statement:

```
PRINT D$;"Run Interrupter"
```

where D\$ = CHR\$(4) (line 20)

Table 2 - Menu Program

ILIST

```
10 REM MENU FOR THE HPLC INTERFACE
20 D$ = CHR$(4): REM CNTRL D
30 HOME
40 HTAB 5: PRINT "MENU FOR THE HPLC INTERFACE"
50 PRINT : PRINT
60 INVERSE
70 PRINT "1. DATA COLLECTION "
80 PRINT : PRINT
90 PRINT "2. PLOT "
100 PRINT : PRINT
110 PRINT "3. INTEGRATE "
120 PRINT : PRINT
130 PRINT "4. ADJUST BASELINE"
140 PRINT : PRINT
150 PRINT "5.LOAD DATA"
160 PRINT : PRINT : PRINT "6.QUIT"
170 NORMAL
180 PRINT : PRINT : PRINT
190 INPUT "ENTER A NUMBER AND PRESS RETURN. ";NB
200 PRINT
210 ON NB = 1 GOSUB 270
220 ON NB = 2 GOSUB 290
230 ON NB = 3 GOSUB 310
240 ON NB = 4 GOSUB 320
250 ON NB = 5 GOSUB 330
260 END
270 PRINT D$;"RUN INTERRUPTER
280 RETURN
290 PRINT D$;"RUN AXISLABEL"
300 RETURN
310 PRINT D$;"RUN ITGRT"
320 PRINT D$;"RUN BASESET"
330 PRINT D$;"RUN DATALOAD"
340 RETURN
```

J

instructs the Apple to run the program Interrupter. The Apple will run this program just as if the user himself had typed "Run Interrupter". This command will be extremely useful, for it allows us to communicate with the disk drives, i.e. to run other programs and load binary files. In fact, it is used in all of the programs of the interface system.

## 2) Interrupter

The key to the interface system is the Interrupter program. (Table 3) The function of this program is to monitor the discrete digital signal on one second intervals and store the digital value in successive memory locations in the Apple. This program can be divided into two distinct parts based on the computer language being used: an interrupt routine and a data acquisition and storage section. The interrupt part of the program is accomplished with three assembly language programs which are run within the Interrupter program. The data collection and storage segments of the program are written in Apple BASIC. These segments average the collected digital values and place the average values in successive memory locations.

After selection of Interrupter on the Menu, the computer proceeds to load three binary files into the Apple's memory. (lines 110-130) The interrupt part of

Table 3 - Interrupter Program

LIST 0,400

```
10 HOME
20 GOSUB 630: REM SETS OFFSET VALUE
70 CH = 4: REM USING HARDWIRED CIRCUIT
80 HOME
90 HTAB 12: VTAB 15: PRINT "LOADING FILES...."
100 D$ = CHR$ (4)
110 REM THE NEXT THREE STEPS CONSIST OF LOADING THE MACHINE LANGUAGE PRO
GRAMS NECESSARY FOR THE INTERRUPT PROGRAM
120 PRINT D$;"BLOAD A/DMOVE.OBJ0": REM LOADED AT 768
130 PRINT D$;"BLOAD INTRUPTOFF": REM LOADED AT 857
140 PRINT D$;"BLOAD INTRUPT.OBJ0": REM LOADED AT 830
150 FLAG = 829: REM MEM LOC FOR INTERRUPT FLAG
160 STRBS = 24576: REM DATA STORED HERE & UP
170 ADDR = 49312 + CH: REM SLOT 2 FOR A/D
180 REM THE INTERRUPT ROUTINE IS AT LOC 768. IT STORES AN A/D VALUE AT 8
28 AND SETS A FLAG AT 829.
190 HOME : HTAB 15: VTAB 15: FLASH : PRINT "INJECT SAMPLE": PRINT : PRINT
: PRINT "PUSH RED BUTTON ON PADDLE 0": NORMAL
200 GOSUB 560
210 X = PEEK (ADDR): REM STARTS A/D
220 REM A NULL READING OR PRIME FOR THE A/D
230 N = 0
240 NPT = 100: REM # OF DATA PTS
250 POKE FLAG,0: REM SETS FLAG AT 0
260 CALL 830: REM TURNS ON 1 SEC INTRPTS
270 IF PEEK (FLAG) = 0 THEN GOTO 390
280 ANS = 0
290 REM FOLLOWING LOOP IS AN AVERAGING LOOP FOR THE A/D
300 FOR I = 1 TO 20
310 ANS = ANS + PEEK (ADDR)
320 NEXT I
330 X = ANS / 20
340 POKE STRBS + N,X
350 N = N + 1
370 POKE FLAG,0: REM RESETS FLAG
380 IF PEEK ( - 16384) > 127 THEN GOTO 400: REM CHECKS KEYBOARD
390 GOTO 270
400 POKE - 16368,0
```

```
LIST 400,1000
400 POKE - 16368,0
405 SEC = N
440 CALL 857: REM TURNS OFF INTRPTS
450 HOME
451 MI = INT (100 * N / 60 + .5) / 100
452 HTAB 5: VTAB 5: PRINT MI;" MINUTES HAVE ELAPSED."
460 HTAB 5: VTAB 10: INPUT "WOULD YOU LIKE TO SAVE THIS DATA?";Y$
470 IF Y$ = "YES" THEN 490
480 PRINT D$;"RUN MENU REVISED,D1"
490 INPUT "FILENAME?";F$
500 PRINT : INPUT "DISK DRIVE 1 OR 2?";NU
510 REM SAVES DATA AS A BINARY FILE
520 PRINT D$;"BSAVE ";F$;" , A24576, L";SEC;" , D";NU
530 REM CORRECT FORMAT WITH AN ADDED ;
540 GOTO 480
550 REM TAKES YOU BACK TO THE MENU
560 X = PEEK ( - 16287)
570 IF X > 127 THEN GOTO 590
580 GOTO 560
590 POKE - 16296,1
595 FOR I = 1 TO 5
600 C = PEEK ( - 16336)
601 NEXT I
610 HOME : HTAB 12: VTAB 15: INVERSE : PRINT "COLLECTING DATA...": NORMAL
620 RETURN
630 REM SETS OFFSET VOLTAGE AT - 5 VOLTS
640 SN = 2
650 VOLT = 8
660 BASE = 49280:CH = 3
670 FOR I = 1 TO 20
680 ADDR = BASE + SN * 16 + CH
690 POKE ADDR,VOLT
700 NEXT I
710 RETURN
```

this program is then begun by pressing the red button on game control #0.

Upon starting, the Apple sets the Flag value at 0 (Line 220) using the "Poke" statement. This is an important command in Apple BASIC which will be used later in this program for storage of the average digital values. This command stores a digital value, in this case 0, at a specified memory location. Here the memory location, 829, was set equal to Flag, so that the statement is written as follows:

```
POKE Flag,0
```

With the Flag set equal to zero, the program proceeds to line 230, which is where the binary files take control of the programming. The first in the series of assembly language programs is INTRUPT.OBJ0, which was loaded at memory location 830. (Note : the command in line 230 refers to memory location 830.) This routine sets up the interrupts by turning on the Apple clock board, line 034C-. (Table 4) It then stores the address of the beginning of the service routine, where the computer will proceed to when an interrupt occurs. The service routine referred to is actually the assembly language program A/DMOVE.OBJ0. (Table 5) The function, therefore, of the first binary file is to



Table 4 - INTRUPT.OBJO Program

\*300L

0300-	A5 45	LDA	*45
0302-	4B	PHA	
0303-	8A	TXA	
0304-	4B	PHA	
0305-	9B	TYA	
0306-	4B	PHA	
0307-	AD C7 C0	LDA	*C0C7
030A-	5B	CLI	
030B-	AD A1 C0	LDA	*C0A1
030E-	BD 3C 03	STA	*033C
0311-	EE 3D 03	INC	*033D
0314-	6B	PLA	
0315-	AB	TAY	
0316-	6B	PLA	
0317-	AA	TAX	
0318-	7B	SEI	
0319-	AD CB C0	LDA	*C0C8
031C-	6B	PLA	
031D-	40	RTI	
031E-	00	BRK	

Table 5 - A/DMOVE.OBJO Program

\*33EL

033E-	48	PHA	
033F-	78	SEI	
0340-	A9 00	LDA	##00
0342-	BD FE 03	STA	\$03FE
0345-	A9 03	LDA	##03
0347-	BD FF 03	STA	\$03FF
034A-	A9 01	LDA	##01
034C-	BD C9 C0	STA	\$C0C9
034F-	58	CLI	
0350-	68	PLA	
0351-	60	RTS	
0352-	00	BRK	
0353-	00	BRK	
0354-	00	BRK	
0355-	00	BRK	
0356-	FF	???	
0357-	FF	???	
0358-	FF	???	
0359-	78	SEI	
035A-	48	PHA	

\*

start the interrupts on the clock board and to tell the computer where to go when an interrupt occurs. In this case, the computer is instructed to run the service routine each time an interrupt occurs.

The service routine instructs the computer to accept interrupts from other peripherals. When an interrupt occurs, this routine reads the A/D value and stores the digital value in memory location 828 (line 030E-). Then, it stores a 1 in memory location 829, which sets the Flag. When the Flag is set at 1, which will be at one second intervals, the BASIC part of the Interrupter program:

- 1)looks at the A/D value (20 times).
- 2)calculates an average value.
- 3)stores the average value.
- 4)resets the flag to zero.

Although these steps will be explained in more detail later on, it is important to mention them here in order to understand the programming design.

The service routine will be repeated on one second intervals, and hence the A/D averaging and storing will be repeated on one second intervals.

When the Interrupter program reaches line 440, the computer is once again instructed to run an assembly

language routine. This routine, stored at memory location 857, corresponds to the INTRUPTOFF binary file. (Table 6) The function of this routine is to turn off the clock board interrupts, lines 035B- and 035D, and to enable the system to be interrupted and have a response other than mentioned above. That is, when an interrupt occurs the computer will no longer run the service routine. Then, this routine returns the computer to the Interrupter program.

At this point, a further description of what the computer does when the Flag is set equal to 1 is in order. The first function performed within the BASIC part of the Interrupter program is to look at the A/D value using the Peek command. This command is the complement of the previously explained Poke command, in that it is used to look at the digital value stored in a particular memory location. The format used when looking at a chosen memory location is as follows:

$X = \text{PEEK}(\text{ADDR})$

where ADDR stands for a particular address or memory location of interest.

When "peeking" at A/D values, the address is specified by an equation which is a function of the slot number for the A/D board and the channel number that is being

Table 6 - INTRUPTOFF Program

359L

0359-	78	SEI	
035A-	48	PHA	
035B-	A9 00	LDA	##00
035D-	8D C9 CO	STA	\$C0C9
0360-	AD C7 CO	LDA	\$C0C7
0363-	AD C8 CO	LDA	\$C0C8
0366-	A9 18	LDA	##18
0368-	B5 23	STA	\$23
036A-	58	CLI	
036B-	68	PLA	
036C-	60	RTS	
036D-	78	SEI	
036E-	60	RTS	
036F-	58	CLI	
0370-	60	RTS	
0371-	03	???	
0372-	FF	???	
0373-	04	???	
0374-	05 06	DRA	\$06
0376-	FF	???	

\*



monitered.

$$\text{ADDR} = 49280 + (\text{slot} * 16) + \text{channel}$$

where

- 1) 49280 is the starting address of all slot dependent locations.
- 2) slot must be from 1 to 7.
- 3) channel must be from 0 to 15. (4)

Since the slot number refers to the place where the A/D board is installed, in this case slot 2, this remains constant in the Interrupter program. Likewise, the channel (channel = 4 in the hardwired circuit) on which data are collected is always the same, so this is also a constant. It is important to mention that one can "peek" at memory locations other than those concerned with A/D conversion by simply specifying the address of interest.

We decided to have the program calculate an average (N=20) for the A/D value due to the fluctuations observed when monitoring single values. It then stores the average digital value at memory locations from 24576 and up. It is worth noting that there are approximately 10,000 memory locations available for data

storage. This means that, when sampling 60 average values per minute, this system is capable of storing almost 3 hours worth of data. This will be more than sufficient for applications involving the HPLC and fluorometer.

Lastly, the program resets the Flag value at 0, which allows the program to be interrupted at the next second interval by the assembly language programs.

Other peripheral functions of the Interrupter program are:

1)to generate the digital value for the D/A converter which is used as an offset voltage for the HPLC op. amp. (Subroutine 640) The program produces a voltage on channel 3 of -5V.

2)to calculate the elapsed time of data collection.  
(Lines 451-452)

3)to allow the user to save collected data to a data diskette. (Lines 490-520)

### 3) Plot

The next step is to display acquired data in graphical form. For the HPLC, we are interested in plotting average digital absorbance value vs. time. This will produce a chromatogram on the high resolution graphics screen of the Apple. On the other hand, for the fluorometer interface system the plot is of average digital emission value vs. wavelength, which yields a fluorescence spectrum. Although data are collected as a function of time for the fluorometer, it is possible to convert the time axis to wavelength by simply incorporating the scan speed for the emission monochromator into the plotting procedure. This will be explained in more detail following a discussion of the HPLC plotting program.

#### A) HPLC - Chromatograms

The plotting program (Table 7 ) for the HPLC interface system has four important functions. These are as follows:

(1) receives input from the user which specifies what range (in minutes) the program will scale and plot a chromatogram.

(2) finds the highest average digital value within a

Table 7 - HPLC Plotting Program

LIST 0,400

```
10 LE = PZ - PA: REM CALC. LENGTH OF PLOT
20 TXTGEN% = 768: REM SPEC. MEM. LOC.
30 D$ = CHR$(4): REM D$ = CNTRL D
39 HOME
40 HTAB 5: VTAB 10: INPUT "PLOTING RANGE (MIN.,MIN.)";PA,PZ
50 HTAB 10: VTAB 15: INPUT "TITLE ?";TITLE$
60 HGR2 : HCOLOR= 3: REM HIGH RES SCREEN #2
70 LE = PZ - PA: REM CALC. LENGTH OF PLOT
80 PRINT D$;"BLOAD TEXT"
90 CALL TXTGEN%
100 HOCH = LE * 60: REM HOCH = RANGE (IN SECONDS)
110 MAX = 0: REM SPECIFIES LOW VALUE THAT PEAK GREATER THAN
120 REM THIS IS USED WHEN SCANNING FOR THE HIGHEST PEAK
130 TREPPEN = 279 / LE
140 REM TREPPEN = STEPS (AUF DEUTSCH), DIVIDES OUR X AXIS INTO MINUTES
150 REM PLOTS X AND Y AXIS
160 HPLOT 0,0 TO 0,147 TO 279,147
170 FOR I = 0 TO 150 STEP 7
180 FOR M = 1 TO 279 STEP TREPPEN
185 ONERR GOTO 900
190 HPLOT M,I TO M + 1,I
200 NEXT M
210 NEXT I
220 FOR L = 0 TO 279 STEP TREPPEN
230 HPLOT L,157 TO L,147: REM X HATCH MARKS
240 NEXT L
250 FOR N = 0 TO 279 STEP TREPPEN / 5: REM DIVIDES MINUTES INTO 20/100 I
    NTERVALS
260 HPLOT N,152 TO N,147: REM X HATCH MARKS
270 NEXT N
280 LA = PA
290 FOR HT = 1 TO 40 STEP 39 / LE
300 VTAB 21: HTAB HT: PRINT LA
310 LA = LA + 1
320 IF LA = PZ THEN HT = HT - 1
330 NEXT HT
340 HTAB 15: VTAB 23: PRINT "TIME (MINUTES)"
350 HTAB 15: VTAB 1: PRINT TITLE$
360 REM NAME STARTING LOCATION
370 STRBS = 24576
380 REM COMPENSATE FOR RANGE PROGRAM BY MOVING TO THE PROPER STARTING LO
    CATION
390 STRBS = STRBS + PA * 60
400 REM FIND THE DIGITAL VALUE FOR THE LARGEST PEAK
```

LIST 400,1000

```
400 REM FIND THE DIGITAL VALUE FOR THE LARGEST PEAK
410 FOR S = 1 TO HOCH
420 RES = PEEK (STRBS)
430 STRBS = STRBS + 1
440 ON RES > MAX GOSUB 650
450 NEXT S
460 STRBS = 24576 + PA * 60
470 REM PLOT THE GRAPH
480 RES = PEEK (STRBS)
490 Y1 = 147 * (1 - (RES / MAX))
500 X1 = 0
510 FOR R = 1 TO HOCH
520 RES = PEEK (STRBS + R)
530 Y2 = 147 * (1 - (RES / MAX))
540 X2 = R * 279 / HOCH
550 H PLOT X1,Y1 TO X2,Y2
560 X1 = X2:Y1 = Y2
570 NEXT R
580 HTAB 28: VTAB 22: PRINT "MAX = ";MAX
590 GET G$
600 HOME : TEXT
605 VTAB 12: HTAB 2: INPUT "WOULD YOU LIKE TO ADJUST THE RANGE?";Y$
606 ON Y$ = "YES" GOSUB 1000
609 HOME
610 VTAB 12: HTAB 8: INPUT "WOULD YOU LIKE A HARDCOPY?";Y$
620 ON Y$ = "YES" GOSUB 670
630 PRINT D$;"RUN MENU REVISED,D1"
640 END
650 MAX = RES
660 RETURN
670 PRINT D$;"RUN EPSON PLOT"
900 GOTO 590
1000 GOTO 10
```

1

1

selected range and scales that value to the full size of the high resolution graphics screen. In addition, it prints the maximum digital value, Max Value, on every chromatogram.

(3) draws an X and Y axis and plots the average digital value vs. time. This includes labeling of the X axis with hatch marks and a title. The user may also choose a title for the entire chromatogram.

(4) allows the user to make a hardcopy of a chromatogram by running the Epson Plot program.

The first of these functions is accomplished in line 40, where the user is asked to specify a plotting range, in minutes. This is extremely useful, since it allows enlargement of particular regions of interest on a chromatogram by simply specifying the appropriate time range. In addition, this input is also used later on in the program to label the X axis in intervals of one minute. Samples of a full chromatogram and one in which a section of the chromatogram has been expanded are shown in figures 6,7, and 8. Given the range over which the program will function, the computer proceeds to scan that range for the maximum average digital value. In lines 400 to 450, the computer compares the average digital values with a low digit (Max = 0 (Line 110)) so that when a peak occurs, its maximum digital value will be greater than Max. When a peak occurs, its

Figure 6 - Plotting Sample of a Full Chromatogram

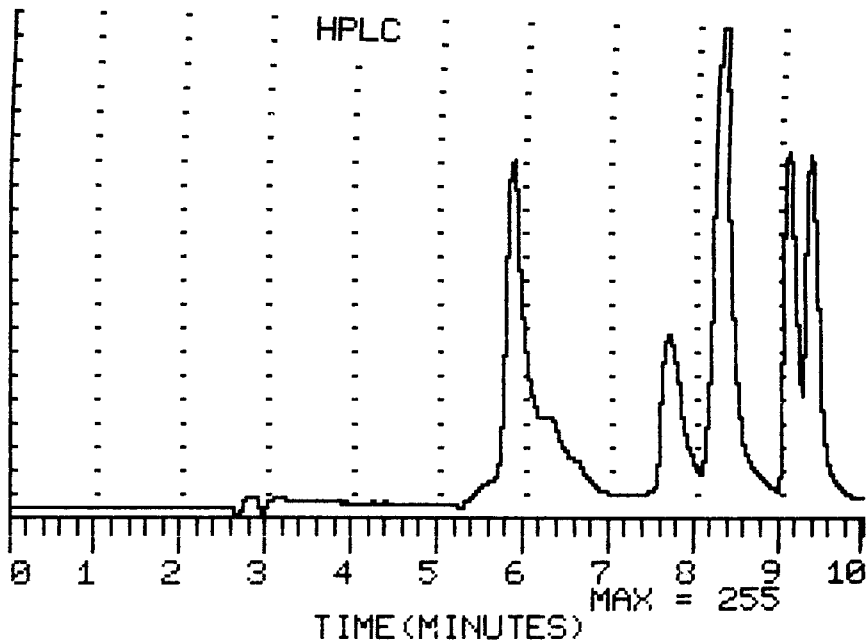



Figure 7 - Plotting Sample which Illustrates Expansion

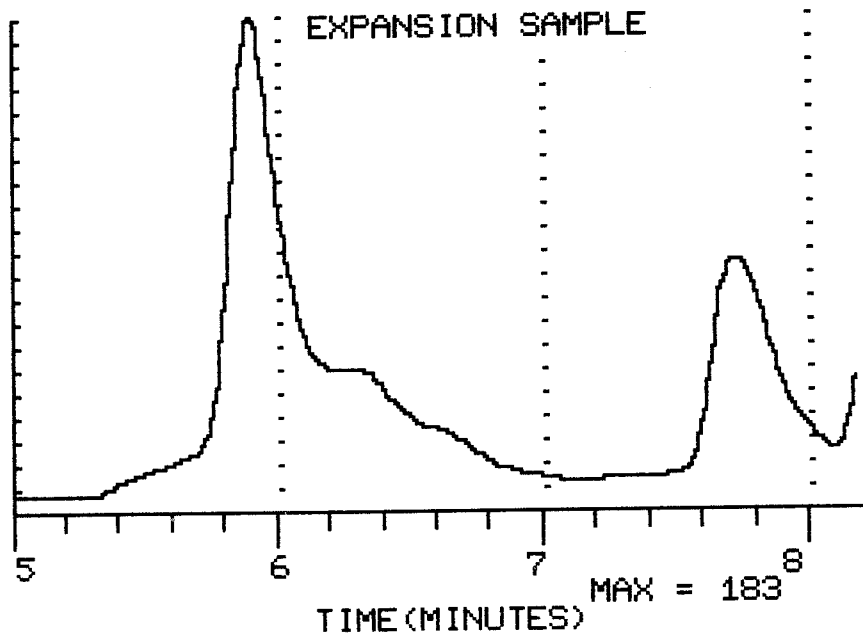
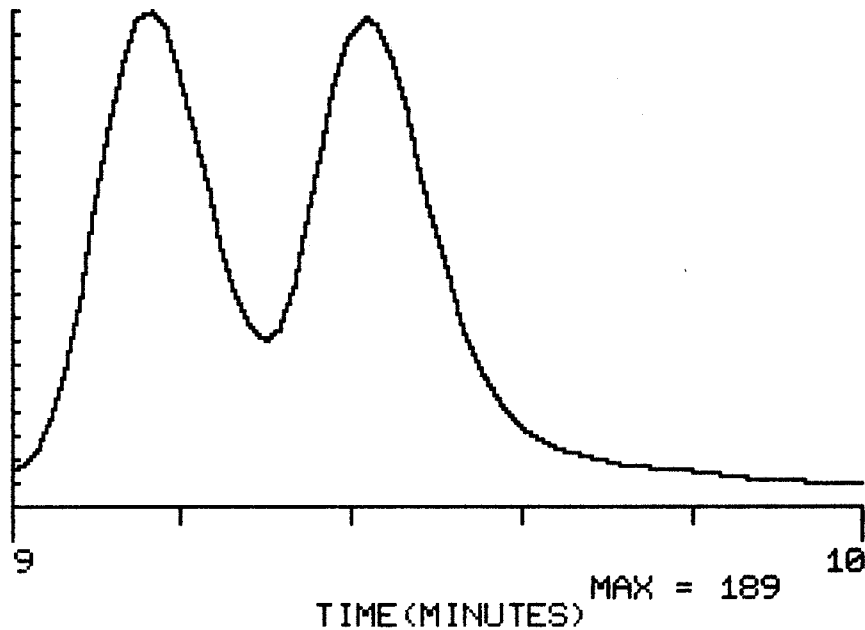

Figure 7 - Expansion Illustration



maximum digital value then becomes the new Max. value (line 440 + 650). The comparison continues until the Max value is the highest average digital value monitored. Scaling of the highest peak to the full size of the high resolution graphics screen is then accomplished in line 490, where the Max value is used to calculate the scaling factor.

Plotting of the X and Y axes is accomplished in lines 150 - 350. This section of the program plots hatch marks at minute intervals within a selected range and divides these intervals into fifths. This makes it easier to read a desired time from a chromatogram. In addition, this is the part of the program that labels the X axis using the entered range for the minute scale. The title is also printed at this point. The examples, shown previously, illustrate the format for these plots.

Finally, this program asks the user whether or not he would like to have a hardcopy of a chromatogram (Line 610). If the answer is yes, the computer then runs the Epson Plot program (Line 670) which prints, on the Epson dot matrix printer, whatever has been written on the Apple high resolution graphics screen. Since this program is a commercial one, we will not explain how the program works. A description of how to use the program is included in the HPLC Interface Operator's Manual,

which is found in the appendix of this paper.

#### B) Fluorometer - Emission Spectrum

It is only necessary to make minor adjustments in the previous HPLC plotting program to plot an emission spectrum. Emission spectra are plots of average digital emission vs. wavelength; therefore, the major change involves relating the monochromator scan speed to the number of data points collected over an interval of time. The Medium scan speed, which is the only one we have chosen to program for, is 100 nanometers per minute. (5) In addition, recall that data points are collected on one second intervals, i.e. 60 data points per minute.

In line 40 (Table 8) the plotting range is entered in nanometers, and this wavelength range is then converted to a time range (in minutes) in line 72. Next the range (in seconds) is calculated in line 100. This conversion of ranges allows us to plot average digital emission values using the same routine as for the HPLC plotting program. (410-570) That is, the plot is actually average digital emission values vs. time. The only difference is that the nanometer scale is printed on the X-axis instead of the calculated time scale. In order to accomplish this, lines 130, 290, 310, and 340

Table 8 - FS Plotting Program

ILIST 0,400

```
5 REM FLUOR PLOT
10 LE = PZ - PA: REM CALC. LENGTH OF PLOT
20 TXTGEN% = 7&8: REM SPEC. MEM. LOC.
30 D% = CHR% (4): REM D% = CNTRL D
39 HOME
40 HTAB 5: VTAB 10: INPUT "PLOTTING RANGE (WAVE1,WAVE2)";PA,PZ
50 HTAB 10: VTAB 15: INPUT "TITLE ?";TITLE%
60 HGR2 : HCOLOR= 3: REM HIGH RES SCREEN #2
70 LE = PZ - PA: REM CALC. LENGTH OF PLOT
72 LL = LE / 100
80 PRINT D%:"BLOAD TEXT"
90 CALL TXTGEN%
100 HOCH = LL * 60: REM HOCH = RANGE IN SECONDS
110 MAX = 0: REM LOW VALUE THAT PEAK GREATER THAN
120 REM THIS IS USED WHEN SCANNING FOR THE HIGHEST PEAK
130 TREPPEN = 2790 * 2 / LE
140 REM TREPPEN = STEPS(AUF DEUTSCH),DIVIDES OUR X AXIS INTO MINUTES
150 REM PLOTS X AND Y AXIS
160 HPLOT 0,0 TO 0,147 TO 279,147
170 FOR I = 0 TO 150 STEP 7
180 FOR M = 1 TO 279 STEP TREPPEN
185 ONERR GOTO 900
190 HPLOT M,I TO M + 1, I
200 NEXT M
210 NEXT I
220 FOR L = 0 TO 279 STEP TREPPEN
230 HPLLOT L,157 TO L,147: REM X HATCH MARKS
240 NEXT L
250 FOR N = 0 TO 279 STEP TREPPEN / 5: REM DIVIDES MINUTES INTO 20/100 I
    NTERVALS
260 HPLLOT N,152 TO N,147: REM X HATCH MARKS
270 NEXT N
280 LA = PA
290 FOR HT = 1 TO 40 STEP 780 / LE
300 VTAB 21: HTAB HT: PRINT LA
310 LA = LA + 10
320 IF LA = PZ THEN HT = HT - 2
330 NEXT HT
340 HTAB 15: VTAB 23: PRINT "WAVELENGTH (NM.)
350 HTAB 15: VTAB 1: PRINT TITLE%
400 REM FIND THE DIGITAL VALUE FOR THE LARGEST PEAK
```

LIST 400,2000

```
400 REM FIND THE DIGITAL VALUE FOR THE LARGEST PEAK
405 STRBS = 24576
410 FOR S = 1 TO HOCH
420 RES = PEEK (STRBS)
430 STRBS = STRBS + 1
440 ON RES > MAX GOSUB 650
450 NEXT S
460 STRBS = 24576
470 REM PLOT THE GRAPH
480 RES = PEEK (STRBS)
490 Y1 = 147 * (1 - (RES / MAX))
500 X1 = 0
510 FOR R = 1 TO HOCH
520 RES = PEEK (STRBS + R)
530 Y2 = 147 * (1 - (RES / MAX))
540 X2 = R * 279 / HOCH
550 HPLOT X1,Y1 TO X2,Y2
560 X1 = X2:Y1 = Y2
570 NEXT R
580 HTAB 28: VTAB 22: PRINT "MAX = ";MAX
590 GET G$
600 HOME : TEXT
610 VTAB 12: HTAB 8: INPUT "WOULD YOU LIKE A HARDCOPY?";Y$
620 ON Y$ = "YES" GOSUB 670
630 PRINT D$;"RUN MENU REVISED,D1"
640 END
650 MAX = RES
660 RETURN
670 PRINT D$;"RUN EPSON PLOT"
900 GOTO 590
```

J

were changed accordingly. An example of an emission spectra is shown in Figure 9.



Figure 9 - Plotting Sample of an Emission Spectrum

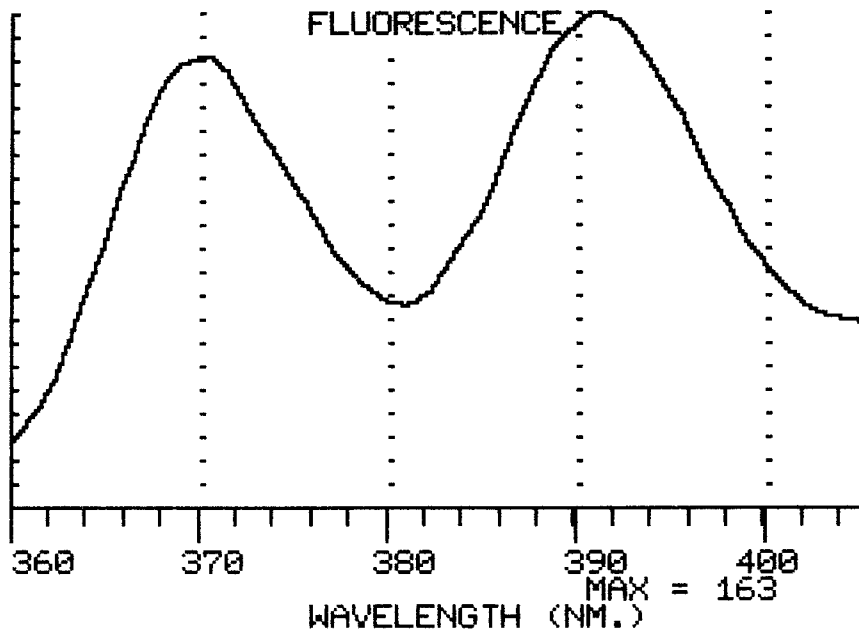

#### 4) Integration

The next step is to calculate useful parameters for a particular plot. Since the integration program (Table 9) was specifically designed for the HPLC interface system, it will be explained with respect to chromatographic data. This program calculates retention times, performs relative and absolute integration, and allows the user to make a hardcopy of these results. The discussion of this program will include a comparison of the relative integration method with the cut-and-weigh method.

This program has the following functions:

- A) displays the previous plot to the user.
- B) receives input which specifies the number of peaks to be integrated.
- C) receives input which specifies the start, end, and selected baseline for a particular peak.
- D) calculates retention times, as well as relative and absolute integration values.
- E) allows the user to make a hardcopy of the integration results.

When a satisfactory plot has been obtained, the next step is to run the Integration program. Displaying

Table 9 - Integration Program

LIST 0,400

```
5 D$ = CHR$(4): REM CNTRL D
10 REM INTEGRATION PROGRAM
15 STRBS = 24576
20 DIM STPK(10): DIM BSPK(10): DIM AREA(10)
30 DIM NDPK(10): DIM PRCNT(10): DIM RTIME(10)
33 : PRINT AREA(L)
35 D$ = CHR$(4): REM CNTR D
40 GOSUB 1000
42 GET G$
45 GOSUB 2000
50 HTAB 10: VTAB 16: INPUT "NUMBER OF PEAKS?";WW
62 N = 1
65 FOR I = 1 TO WW
70 PRINT "PEAK ";I: INPUT "START,END,BASE ?";STPK(N),NDPK(N),BSPK(N)
71 STPK = STPK * 60:NDPK = NDPK * 60:BSPK = BSPK * 60
72 STPK = STPK(N):NDPK = NDPK(N):BSPK = BSPK(N)
76 N = N + 1
77 NEXT I
80 IF STPK(N) < 0 GOTO 140
140 N = N - 1
150 FOR I = 1 TO N
160 WIDEPK = (NDPK(I) - STPK(I)) * 60
165 STRBS = 24576
170 BSAREA = WIDEPK * ( PEEK (STRBS + BSPK(I)) * 60)
180 TAREA = 0
190 FOR TME = STPK(I) * 60 TO NDPK(I) * 60
220 TAREA = TAREA + PEEK (STRBS + TME)
210 NEXT TME
220 AREA(I) = TAREA - BSAREA
230 TTAREA = TTAREA + AREA(I)
240 NEXT I
250 FOR J = 1 TO N
260 PRCNT(J) = 100 * AREA(J) / TTAREA
270 NEXT J
300 FOR K = 1 TO N
310 MAX = STPK(K) * 60
320 VM = PEEK (STRBS + STPK(K)) * 60
330 FOR TM = STPK(K) * 60 TO (NDPK(K)) * 60 - 1
340 V1 = PEEK (STRBS + TM)
360 IF V1 > VM THEN MAX = TM
365 IF V1 > VM THEN VM = V1
370 NEXT TM
380 RTIME(K) = MAX
390 NEXT K
400 GOSUB 750
```

J

LIST 400,3000

```
400 GOSUB 750
405 PRINT : PRINT
425 PRINT
430 INPUT "WOULD YOU LIKE TO INTEGRATE AGAIN?";Y$
435 REM STILL MUST REINIT DATA BEFORE USING
440 IF Y$ = "YES" THEN GOTO 40
450 PRINT D$;"RUN MENU REVISED, D1"
750 HOME : HTAB 2: VTAB 12: INPUT "WOULD YOU LIKE A HARDCOPY?";Y$
755 ON Y$ = "YES" GOSUB 1500
800 HOME
802 PRINT "RET. TIME";: HTAB 13: PRINT "PEAK INTVL.";: HTAB 26: PRINT "ZT
OTAL";: HTAB 35: PRINT "ABS. AREA"
803 HTAB 2: PRINT "(MIN.)";: HTAB 17: PRINT "(MIN.)"
804 PRINT "*****      *****      *****      *****"
805 FOR L = 1 TO N
806 RTIME(L) = RTIME(L) / 60
807 RTIME(L) = INT (RTIME(L) * 10 + .5) / 10
809 N$ = STR$ (PCNT(L))
810 PRINT RTIME(L);: HTAB 13: PRINT STPK(L);"-";NDPK(L);: HTAB 26: PRINT
LEFT$ (N$,5);: HTAB 36: PRINT AREA(L)
830 NEXT L
835 PRINT D$;"PR#0"
840 RETURN
1000 HOME : HTAB 15: VTAB 2: PRINT "INTEGRATION"
1001 HTAB 5: VTAB 5: PRINT "ENTER DATA AS FOLLOWS:"
1002 HTAB 7: VTAB 7: PRINT "START,END,BASELINE"
1005 HTAB 6: VTAB 10: PRINT "DON'T FORGET THE COMMAS OR <RETURN> WHEN ENT
RY IS COMPLETED"
1006 HTAB 5: VTAB 12: PRINT "ENTER <ESC> TO DISPLAY LAST PLOT"
1100 RETURN
1500 PRINT D$;"PR#1"
1505 RETURN
2000 REM DISPLAY GRAPHICS SCREEN
2009 POKE - 16299,0
2010 POKE - 16297,0
2015 POKE - 16304,0
2020 GET G$
2030 TEXT : RETURN
```

J

this plot is accomplished in subroutine 2000. Using specific "Poke" commands, it is possible to have the computer display the last plot from the high resolution graphics screen. The addresses which are being "poked" and a discussion of their function can be found in the Apple BASIC Reference Manual. (6) This feature is convenient because it allows the user to identify locations of peaks during the actual integration program.

Next, the user enters the number of peaks to be integrated. (Line 50) This program is capable of performing integration of up to ten peaks. This upper limit is specified in lines 20-30, where input data as well as intermediate calculated values are dimensioned.

After viewing the plot and determining the Start, End, and Base time values of each peak, the user enters these values at line 70. The Base input may be different for each peak, in order to compensate for a drifting baseline.

At this point, a discussion of the method of integration performed by this program is in order. Basically, the method involves adding up all the average digital values within the chosen time interval (Lines 150-240) and subtracting the average digital value for the baseline (Line 220). This sum corresponds to the absolute integration value, and with it the relative

percentages can be calculated (Lines 250 - 270). Then, the maximum value for each peak is calculated (Lines 300 - 390) The time at which a maximum value occurs corresponds to the retention time of that peak.

Lastly, the user is given the option to obtain a hardcopy of the integration results. If the printer is not connected to the system, the user should answer no here and integration results will simply appear on the Apple graphics screen. On the other hand, if the printer is connected to the system, a hardcopy of integration results may be obtained by answering yes to this question. Further instructions on the use of this program are included in the user's manual in the appendix of this paper.

As a test of the reliability of the integration method employed in this program, we compared the relative percentages for two peaks with the "cut-and-weigh" method (Table 10 ). The results are satisfactory, in that the percent deviation is less than 3%. The absolute integration values, which simply correspond to the digital sum, can be very useful when doing comparative concentration calculations.

Table 10 - Integration Comparison



IRUN  
0

INTEGRATION  
ENTER DATA AS FOLLOWS:  
START,END,BASELINE  
DON'T FORGET THE COMMAS OR <RETURN> WHEN ENTRY IS COMPLETED  
ENTER <ESC> TO DISPLAY LAST PLOT  
NUMBER OF PEAKS?2

PEAK 1  
START,END,BASE ?5.3,7.0,5.3  
PEAK 2  
START,END,BASE ??7.5,8.15,7.5  
WOULD YOU LIKE A HARDCOPY?

RET. TIME (MIN.)	PEAK INTVL. (MIN.)	YES %TOTAL	ABS. AREA
*****	*****	*****	*****
5.9	5.3-7	75.97	4183
7.7	7.5-8.15	24.02	1323

Cut and Weigh

Ret. Time (min.)	Weight (g.)	% Total
5.9	.2351	74.27
7.7	.0605	25.73

### 5) Baseline Adjust

Sometimes during an experiment with the HPLC it is necessary to adjust the level of the baseline on the chart recorder. Likewise, certain applications with the interface system will require a range adjustment of the HPLC op. amp. For this reason, a program (Table 11) has been created which allows the user to monitor and alter the upper and lower limits of the HPLC op. amp. output voltage. These adjustments are accomplished using the 500 ohm variable resistor which was included in the HPLC op. amp. design.

This program "pokes" specific digital values into designated memory locations, which corresponds to having an offset voltage of  $-4.56V$  (Line 100 (V1)) and an input voltage,  $E(i)$ , of  $1V$  (Line 100 (V2)). Notice that channel three is being used for the offset voltage and channel 10 is being used for  $E(i)$ . (Lines 30 + 70) Further, this program displays, on the graphics screen of the Apple, the output voltage,  $E(2)$ , from the HPLC op. amp. as well as the corresponding digital value. With a small screwdriver, the user may adjust the lower limit by turning the screw on the 500 ohm variable resistor, which protudes from the box that encloses the HPLC op. amp. At the same time, the user can view the resulting changes on the Apple graphics screen. In

Table 11 - Baseline Adjust Program

LIST

```
10 REM CHECK OP.AMP.
20 ANS = 0:BASE = 49280
30 SN = 2:CH = 3:CB 10
40 V1 = 11:V2 = 153
50 HOME
60 GOSUB 140
70 ADDR = BASE + SN * 16 + CH: REM ADDRESS FOR -5 VOLTS
80 ARDD = BASE + SN * 16 + CB
90 FOR I = 1 TO 20
100 POKE ADDR,V1: POKE ARDD,V2
110 NEXT I
120 GOSUB 180
130 END
140 HTAB 15: VTAB 2: PRINT "ADJUST BASELINE"
150 HTAB 15: VTAB 13: PRINT "DIGIT"
160 HTAB 30: VTAB 13: PRINT "VOLTAGE"
170 RETURN
180 FOR I = 1 TO 50
190 ANS = ANS + PEEK (49316)
200 NEXT I
210 W = ANS / 50
220 ANS = 0
230 W = INT (W * 100 + .5) / 100
240 Q = (W - 127.5) / 25.5
250 Q = ( INT (100 * Q + .5) ) / 100
255 INVERSE : HTAB 15: VTAB 16: PRINT W: HTAB 33: VTAB 16: PRINT Q: NORMAL

265 IF W > 100 THEN GOSUB 500
266 IF W < 10 THEN GOSUB 520
270 KEY = PEEK ( - 16384)
280 IF KEY > 127 THEN 320
290 NORMAL
295 HTAB 10: VTAB 19: PRINT "HIT ANY KEY TO CONTINUE"
300 GOTO 180
310 RETURN
320 POKE - 16368,0
330 NORMAL
340 HTAB 5: VTAB 20: PRINT "DONE"
350 GOSUB 370
355 PRINT CHR$( 4):"RUN MENU REVISED"
360 END
370 FOR I = 1 TO 10
380 POKE ARDD,128
390 NEXT I
400 PRINT "VALUE RESET"
410 RETURN
500 HTAB 18: VTAB 12: PRINT "UPPER LIMIT"
510 RETURN
520 HTAB 18: VTAB 12: PRINT "LOWER LIMIT"
525 NORMAL : HTAB 19: VTAB 16: PRINT " "
530 RETURN
```

effect, the Apple is being used as a digital voltmeter.

When the adjustment of the lower limit has been completed, the user can flip a switch on the HPLC op. amp. (from Standard to Basaset) that will change the input at E(i) from 0V to 1V. This way, it is possible to see the upper limit of the new range.

Further instructions on the use of this program are included in the user's manual in the appendix of this paper. One should note that baseline adjustment will not be necessary in most cases.

#### 6) Load Data Files

The last program on the Menu allows the user to load previously obtained data into the memory of the Apple. The program (Table 12) was designed so that the Interface diskette must be in diskdrive one and the Data diskette must be in diskdrive two. With that, the program asks the user whether or not he would like a display of the available data files in line 100. If the user answers yes, then a "catalog" is displayed on the Apple's screen. (Line 152) Then, the user is asked to enter the name of the data file he wishes to load. (Line 25) If the file is successfully loaded, the program returns the user to the Menu. (Line 35) If not, the user may try to load another file or correct any mistake that might have been made in the entry.

Table 12 - Load Data File Program

]

LIST

```
5 D$ = CHR$(4): REM CNTRL D
10 REM LOAD DATA FILE
11 HOME
12 GOSUB 100
15 HOME : PRINT : HTAB 5: PRINT "YOU CAN LOAD PREVIOUS DATA INTO"
20 PRINT : HTAB 3: PRINT "MEMORY BY SIMPLY SPECIFYING THE"
22 PRINT : HTAB 3: PRINT "FILENAME."
25 PRINT : INPUT "FILENAME?";FI$
27 N = 2
29 ONERR GOTO 39
30 PRINT D$;"BLOAD ";FI$;" , D";N
35 PRINT D$;"RUN MENU REVISED,D1"
39 HOME
40 HTAB 12: VTAB 14: PRINT "NO FILES FOUND"
42 HTAB 12: VTAB 16: INPUT "TRY AGAIN?";Y$
44 IF Y$ = "YES" THEN 15
45 IF Y$ = "NO" THEN 35
100 HTAB 5: VTAB 2: INPUT "CATALOG?";Y$
110 IF Y$ = "YES" THEN 150
120 RETURN
150 HOME : INVERSE : PRINT "AVAILABE FILES": NORMAL
152 PRINT D$;"CATALOG,D2"
154 INVERSE : PRINT "HIT ANY KEY TO CONTINUE": NORMAL : GET G$
156 GOTO 25
```

]

(Line 42)

This program facilitates quick processing of data which has been stored on diskette. In fact, most of the time processing of the data will occur after the actual run has taken place.



CONFIDENTIAL 5-31-77  
11-77

Although we are quite satisfied with the results of this project thusfar, there is still room for improvement in certain areas. Since we now realize the potential of this system, it is appropriate to mention our future research goals.

First, the method of starting data collection on the HPLC should be changed. It is possible to use the Event option on the HPLC to program a contact closure to occur when the Start button is pressed on the HPLC. This contact closure, or short circuit, could then be monitored by the A/D convertor using software similar to that used for data collection. In short, pressing the Start button on the HPLC would trigger the start of data collection.

There are some minor alterations of the plotting program which should be made. For example, it would be more convenient if plot titles could be typed directly on the high resolution graphics screen after a plot has been displayed. Once the title is specified, the user should then be able to move it to a desired location on the screen using designated keys on the Apple's keyboard.

It would also be useful to perform spectral correction for fluorescence emission and excitation spectra. For emission spectra the non-linear correction

curve corrects for variation in detector sensitivity and emission monochrometer efficiency as a function of wavelength. On the other hand, the correction curve for excitation spectra corrects for variation of lamp intensity and excitation monochrometer efficiency as a function of wavelength. Correction factors are then divided into actual emission and excitation readings in order to obtain the true emission and excitation values. We plan to plot these correction curves and calculate correction factors for the appropriate nanometer readings, i.e. on one second intervals. Then, the correction values will be included in a DATA statement in the fluorometer's plotting program. This way the user will be able to print both the actual and corrected fluorescence spectrum.

Next, an optional automatic integration program would be very useful. This would allow the user to obtain relative and absolute integration results without making an entry. In other words, the computer would scan the average digital values for a plot and, using a slope calculating routine, define peak intervals automatically. This would not replace the present integration program; rather, it would be available for those who did not wish define peak intervals themselves. In addition, it might be easier if the present input format for the integration routine were changed. It has

been suggested that entering peak interval data while viewing the plot would be more convenient.

Future research also includes designing interface systems for other chemical instrumentation. For example, we are considering a flash photolysis interface, which would involve monitoring the A/D signal on a much smaller time interval.

Finally, the interface design research has been written up on a word processor. This allows us to make corrections or additions to the user's manual easily.

REFERENCES

- (1) A/D + D/A Operating Manual, Mountain Computer Inc., 1980
- (2) IBID, Chapter 3
- (3) BASIC Programming Reference Manual, Apple Computer Inc., 1978
- (4) A/D + D/A Operating Manual, Mountain Computer Inc., 1980, pg. 8-2
- (5) Instructions Manual Spectrophotofluorimeter, Perking Elmer Norwalk, Conn., pg. 2-11
- (6) BASIC Programming Reference Manual, Apple Computer Inc., 1978

APPENDIX

The purpose of this manual is to describe the use of the HPLC Apple Two+ system. In order to accomplish this, a standard procedure has been created, whereby the user plays a relatively small role in specifying certain parameters of the system. Of course, it is also possible for the user to fit this system to a particular application, in which case a more in depth understanding of the function and potential of this system is necessary.

#### SETUP

To begin, one must move the computer to the instrumentation lab and make the proper external connections. The latter part of this task should be relatively straightforward, since the electrical connections will involve simple connections with banana plugs. This will be more clearly explained and diagramed in the following section. Note: The Apple is very sensitive to being handled and extreme care must be taken during this portion of the interfacing procedure. For this reason, you should closely follow these steps:

- 1) Turn off the switch on the main power outlet and then unplug the main power plug.

2)Unplug the ribbon cord (grey with red and green) which connects the printer to the Apple. To do this, gently fold the two metal clips, located on opposite sides of the plug in the left rear of the printer, toward the printer. This will release the plug so that it can easily be removed and thereby freeing the Apple from the printer. Keep this ribbon cable with the Apple and avoid entangling it with any other wires from the printer.

3)Remove all diskettes from the disk drives, since slight movement of the drives may scratch any disks left there.

4)With a partner, move the Apple onto the computer cart taking care not to disrupt any of the connections in the rear of the Apple. Make sure that there is a screen, two diskdrives, two blue ribbon cables, one grey ribbon cable (from the printer), two paddle game controls, and an extension outlet attached to the apple. If there is any doubt at this point, please don't hesitate to ask Prof. Werner or Prof. Hull.

With the computer securely on the cart, wheel the cart to the instrumentation lab. Bring the cart behind the bench where the HPLC is located. Plug in the main power plug, but don't turn the min power switch back on yet!

Once you start moving things around, it is your

responsibility to make sure everything is returned to its original location. If any problems occur during the run, first note them in the interface logbook and then report them to a member of the chemistry department. In any case, sign your name in the logbook when the computer has been returned to the computer room.

### CONNECTIONS

As mentioned previously, this portion of the interface should be relatively simple, since all of the electrical connections have been clearly labeled and diagrammed (Figure I). Match the labels from the operational amplifier (op. amp.) with those on the power supply, which you will find in the computer room with the interface diskettes on the top shelf of the white cabinet. You will notice two inputs on the op. amp., HPLC + WWD (variable wavelength detector) and VOLTMETER +, which don't have a match on the power supply. The voltmeter input must be connected with the positive terminal of a voltmeter by a banana cord. This is essential, so that the electrical signal doesn't drift, and, in addition, it allows the user to monitor the output of the op. amp. This will be useful when adjusting the baseline, which is discussed in a later



Figure I - Connections

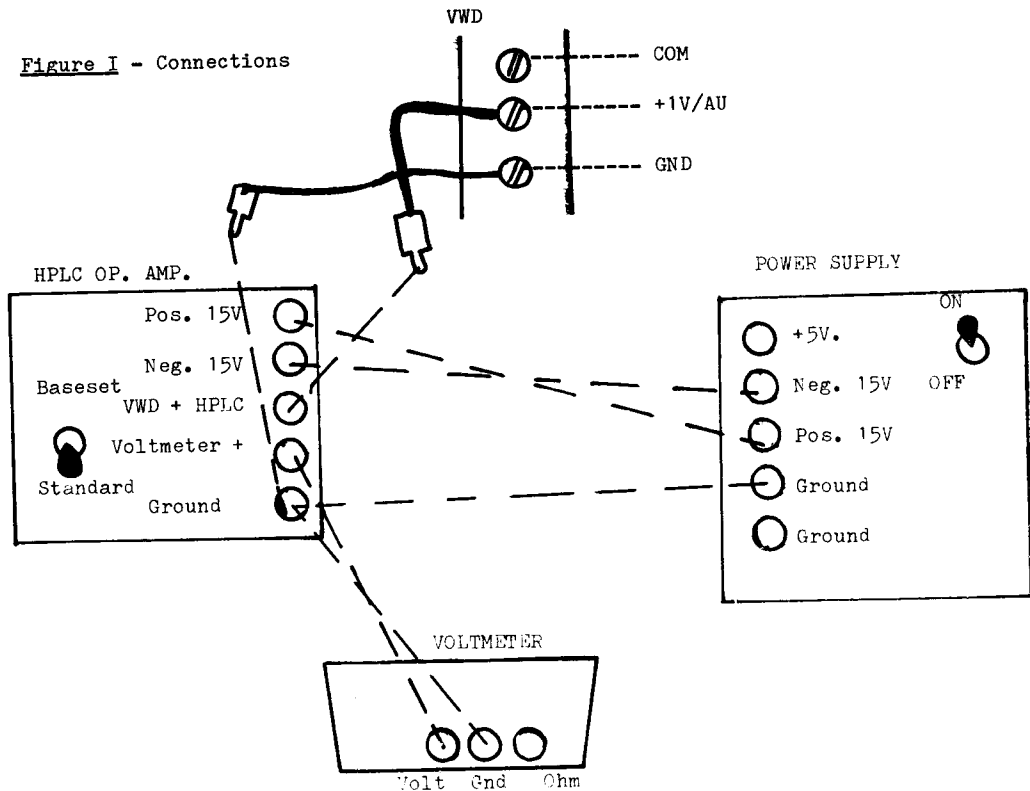

section. The HPLC input on the op. amp. should have the output from the WVD plugged into it. This is the signal being monitored, so be sure not to forget this connection. Of the two outputs from the WVD, connect the one with the white label to the HPLC input and the other (yellow) banana plug to ground. Finally, be certain that the switch on the op. amp. is on standard. (Note: At this point nothing plugged into an electrical outlet should be turned on. Instructions for this come in step one of the software section.)

#### SOFTWARE

At this point, we are almost ready to start taking data from the HPLC. The only element missing is the software which runs the system. You will find the two disks located in a black box labeled HPLC INTERFACE on the top shelf of the white cabinet in the computer room. When finished, please return the box to the location to make it easier for others to find them. This box contains the HPLC INTERFACE and DATA STORAGE disks. Beginning with data collection, the following steps will work through a standard run.

##### Data Collection

###### Step 1

Gently slide the HPLC INTERFACE disk into disk

drive number one and the DATA STORAGE disk into disk drive number two, then close the black lids securing both of the disks. Don't force the disks into the drive, because the disks, as well as the drives, are very sensitive. Even a slight scratch on one of the disks might ruin the programs or data stored there. Next turn on the power by switching on the extension outlet. The red light on drive one will go on, and the disk will spin for about 15 seconds. During this time make sure that the power supply is plugged into an electrical outlet, and then turn on the power supply. When the red light goes off and the whirring noise has ceased, a menu will appear on the screen.

#### Step 2

The menu on the screen presents six different choices. The command on the screen says to select a number and press (Return). (Note: Commands within brackets refer to keys on the keyboard) For the standard run, the user should select number one, which corresponds to the interrupter program. This selection causes the computer to load the necessary binary files for the interface.

#### Step 3

Once the files have been loaded, the Apple flashes

the following message on the screen:

Inject Sample

This signifies that the Apple is ready to start taking data. To initiate data collection the user must 1)inject the sample, 2)push the start button on the HPLC, 3)push the red button on game control 2, and 4)turn on the recorder at approximately the same time. Naturally, this is difficult even for the most gifted, since it involves being in four places at one time. For now this will have to do, and it's suggested that this is done with a partner. However, future plans include reducing the number of tasks to make it easier for the user.

Step 4

To terminate data collection, press the space key. A question will be posed as to whether or not the data should be forgotten. Most of the time the data should be saved to disk; therefore, answer no to this question. If it would be more appropriate to view the chromatogram before making this decision, answer yes and proceed to the plotting program. There will still be another chance, called Datasave, to save these data to disk.

When saving data it is necessary to specify a filename. This is of course a personal choice, except that choosing a name that's already been used on the

data disk should be avoided; otherwise, the older version of the file will be deleted. For this reason, before entering a filename take note of the existing filenames as they are displayed on the screen. It is advisable to choose a filename that is pertinent to the nature of the data being saved, or else it might be difficult to know which filename corresponds to a certain run.

#### Display Data

Once the data have been saved to disk, the user will be returned to the menu. The next logical step is to plot the data, which corresponds to choice two on the menu. With this selection, the computer will ask for a range over which it should scale and plot the data stored in memory. To start, this entry should be the range of the entire chromatogram. For example, if the run were seven minutes long the entry would be:

0,7 (Return)

Next, the user has the option of selecting a title. If the user would rather not title a plot, he should simply press (Return) in response to this question. For instance, one might choose the following title:

HPLC RUN 1 (Return)

There is no need to capitalize, for all letters will be printed in capital letters on the plot. Once the chromatogram has been displayed in its entirety, pressing the space bar will take the computer out of the graphics mode. It will then be possible to make a hardcopy of the display, which is explained in the following section, if the Apple is connected to the printer. It should be noted that it is possible to blow up a particular region of a plot using this program. That is, the computer can scale an entered range to the full size of the graphics screen. For example, if the portion of interest is between five and seven minutes, one would simply enter that range using whole numbers as follows:

5,7 (Return)

Samples of a total chromatogram and a "rangeplot" are found on page .

#### Make a Hardcopy

At this point it may be useful to obtain a printout of the chromatogram. The first requirement for this program is that the Apple be connected to the printer. To make a hardcopy, answer yes to the last question at

the end of the display data program, and the computer will load the necessary files. A new display will appear on the screen, which has a different format than the other programs thusfar described. The difference is this display has default values for the first four choices on the screen. The values, which are printed inversely, i.e. black on white, are the default values, and to change these values press the number corresponding to that line. The inverse type will move over to the next value to show that the change has been accomplished. In order to obtain a printout, it is essential that the first default value, which refers to the choice of pages (1 or 2) on the high resolution graphics screen, be changed from 1 to 2. To do this, simply press one. Otherwise, selections are personal preferences, so that the user decides whether or not to have a normal or enlarged printout. Likewise, the centering of the plot, as well as the mode of the printing, are selections made by the user. In order not to damage the printer, refrain from using the printer in the inverse mode for an extended period of time.

Once the parameters have been specified, check to see what is about to be printed by selecting number six. Before starting to print, be certain that the printing head is at the desired position on the page. This is controlled by two white buttons, labeled FF and LF,

located beneath the ON LINE button on the printer. To move the printer head to the beginning of a new page the printer must be off line, which means that the green light beside the ON LINE button is not illuminated. With that, the page can be moved using the LF (line feed) button. When the page is in the desired position switch the computer back "on line" and select number seven of the plotting program. To print the enlarged version, it will take from two to three minutes. Once the printer has stopped, and the display consists of the various default values, (Cntrl C) will return the computer to the menu.



INTEGRATION

Once the data have been plotted, the user can perform relative and absolute integration and calculate retention times of selected peaks. This corresponds to the "integration" choice on the menu.

First, this program will display directions on the Apple graphics screen, which explain the input format for the integration program. When the user hits the (ESC) key, the present chromatogram will be displayed on the Apple high resolution graphics screen. At this point, the user must note the following:

- 1) the number of peaks to be integrated.
- 2) the "start" and "end" of each peak to be integrated.
- 3) the selected baseline for each peak.

It is advisable to write down these parameters while viewing the chromatogram.

With that, pressing any key will return the user to the original screen to enter the appropriate information. First, the number of peaks will be entered. (Note: this program is capable of integrating up to ten peaks.) Next, the peak intervals, i.e. Start, End, Base, are entered for each peak. After the peak

interval for the last peak has been entered, the user may choose to obtain a hardcopy of the integration results. As with the plotting programs, it is essential that the Apple be connected to the Epson printer in order to obtain a printout of these results. It is also possible to have results displayed on the Apple graphics screen. The latter will be useful when integration is performed in the laboratory. A sample of the input format and integration results display is shown in Table 10. A comparison of the Apple's integration method with the cut-and-weigh method is also found in this table.

#### LOAD DATA FILES

Most of the time, data will be processed after the experiment is completed. This means that data files must be retrieved from disk and stored in the Apple's memory, in order to process data. Selection five on the menu allows the user to look at the available data files on a Data Diskette and load a particular file into the Apple's memory.

It is essential that data diskettes always be inserted in diskdrive 2 and that the interface diskette be inserted in diskdrive 1.

To see a display of the available data files, the

user should answer yes to the initial question of this program. On the other hand, if the user is certain of the title of a particular data file, he may answer no here, and simply input the filename. Either way, after the data file has been loaded, the user will be returned to the menu. In the event that an error was made in entering the title of the data file, the user will be asked whether or not he wishes to try to load that file again.

#### MAKE A DATA DISKETTE

A data diskette is simply an initialized diskette. To initialize a diskette it is necessary to have a greeting program. If you would like to write this program yourself, it is clearly explained on page 14 of The DOS Manual. Otherwise, the following instructions will also enable you to initialize a diskette.

- 1)choose selection on the menu.
- 2)type "New". (Return)
- 3)type "Load Ciao". (Return)
- 4)remove the interface diskette from diskdrive 1!
- 5)place the new diskette in diskdrive 1.
- 6)type "Init ciao". (Return)

The diskdrive will spin and make noises for about a minute. When the light on diskdrive one goes off the

initialization is finished. Then, simply label this disk appropriately.

#### ADJUST BASELINE

It should be emphasized that it is not necessary to use this program for most runs on the HPLC. However, if a situation arises where the range of the HPLC op. amp. must be adjusted, this program will help perform that adjustment.

First, it is necessary to connect the power supply and voltmeter to the HPLC op. amp. as shown in Fig. I. The only difference is that the WVD is not connected to the op. amp. Note that the A/D and D/A cables must also be connected.

To adjust the lower limit of the op. amp., i.e. the baseline, the toggle switch on the HPLC op. amp. should be set on standard. When everything is set and plugged in, the user makes selection four on the menu. A digital voltmeter will be displayed on the right side of the screen which will show the lower limit of the HPLC op. amp. output, E(2). This may be adjusted using the variable resistor which protrudes from the HPLC op. amp. This reading corresponds to the application of zero volts to the op. amp's signal input, E(i), with a -4.74V offset voltage. Remember that the A/D convertor

UN82 MEYER, J.R. MICROCOMPUTER INTERFACING WITH, ETC.  
M612m/1982 CHEMISTRY HRS. 5/82 SHT. 2 OF 2



END

will not accept voltages less than -5V.

To adjust the upper limit of the op. amp's. range, simply switch the toggle on the HPLC op. amp. to the baseset setting. With that, adjustments can be made using the variable resistor. This corresponds to applying 1V to the op. amp's. signal input and with a -4.74V offset voltage. Remember that the A/D convertor will not accept voltages greater than +5V.

If you decide to adjust the baseline, please do not forget to reset the variable resistor at the end of your experiment. The lower limit should be -4.76V and the upper limit should be +4.72V.

For more involved users, another way to change the range of the HPLC op. amp. involves changing the offset voltage within the baseline adjust program. This corresponds to changing the digital value of V1 in line 40 of this program. (Table 11) When a satisfactory range is obtained, the same change must be made in the Interrupter program. (Line 650, Table 3).